

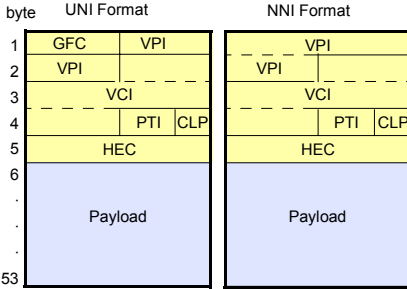

Trend's ATM Guide

Quick Reference for ATM testing



AuroraForte

A powerful tool for testing the Physical, ATM and IP layer operation of ATM circuits. Provides IMA, E1, E3, DS1, DS3, ATM25, STM1/OC3 and STM4/OC12 interfaces for unparalleled multi-circuit testing ATM, xDSL and 3G networks. Physical and ATM BER testing is provided. Advanced features, AAL5, OAM, QoS, SVC support and IP Ping over ATM, protocol decoding and remote testing, analysis of IP traffic composition.



VictoriaSDH/ATM/IP

This family of testers combines full SDH/SONET features up to 2.5 Gbit/s and ATM capabilities up to 155Mbit/s. Transmission functions include TCM, APS, M/N alarms G.783 sequences, frequency deviation and nx64 and Nx56kbit/s tests at E1 and DS1 levels. ATM features include generation and analysis of ATM flows, QoS, OAM flows, generating and analysing AAL1, AAL2, AAL5, and also provides analysis of IP traffic composition.

Figure 1 ATM Cell format

Function	VPI	VCI	PTI	CLP
Unassigned	0	0	any	0
Invalid	<> 0	any	any	0
Idle	0	0	0	1
Metasignaling UNI	*any	1	0xx	any
Broadcast UNI	*any	2	any	any
Segment OAM F4	any	3	0xx	any
E2E OAM F4	any	4	0x0	any
P2P Signaling	*any	5	0xx	any
VP Management	any	6	110	any
ILMI	0	16	z	any
PNNI	0	18	0	any
Segment OAM F5	any	not 0, 3, 4, 6 or 7	100	any
E2E OAM F5	any	not 0, 3, 4, 6 or 7	101	any
VC Management	any	not 0, 3, 4, 6 or 7	110	any
User data	any	> 31	0xx	any

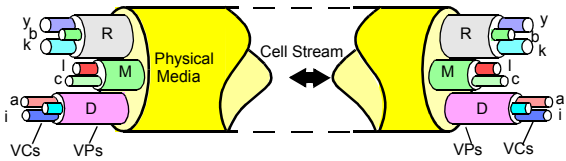

* For VPI=0 the specific VCI is reserved for signalling with the local exchange or ATM switch where the user is connected. For VPI values other than 0 specific VCI value is reserved for signalling with other signalling entities (e.g. other users or remote networks)

Figure 2 Hierarchical representation of VP and VC and reserved VPI/VCI values

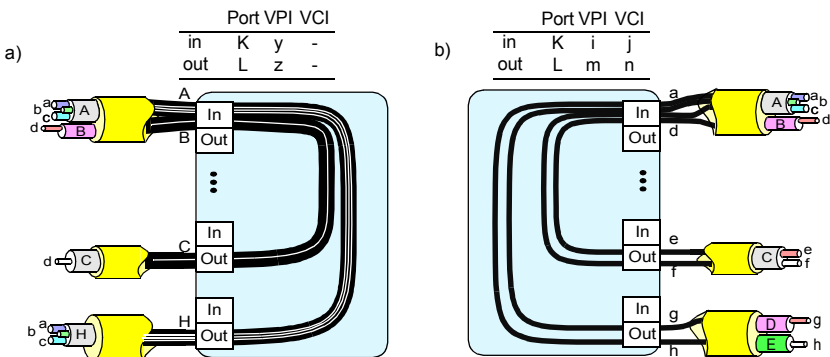

Figure 3 ATM switch operation: a) VP-type b) VC-type

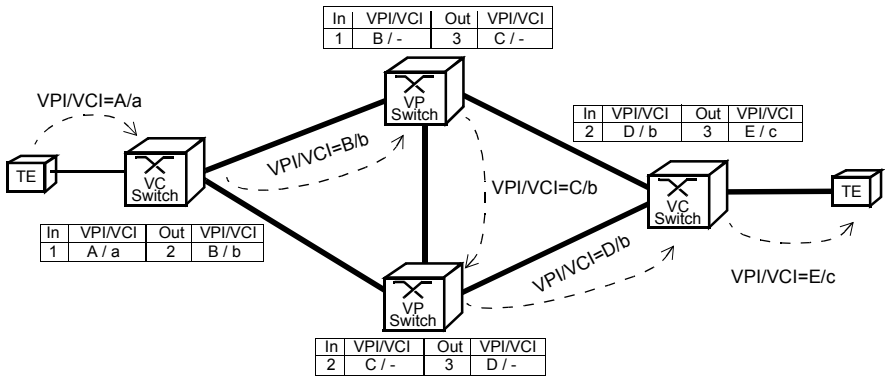

Figure 4 Direction of allocating VPI/VCI identifiers

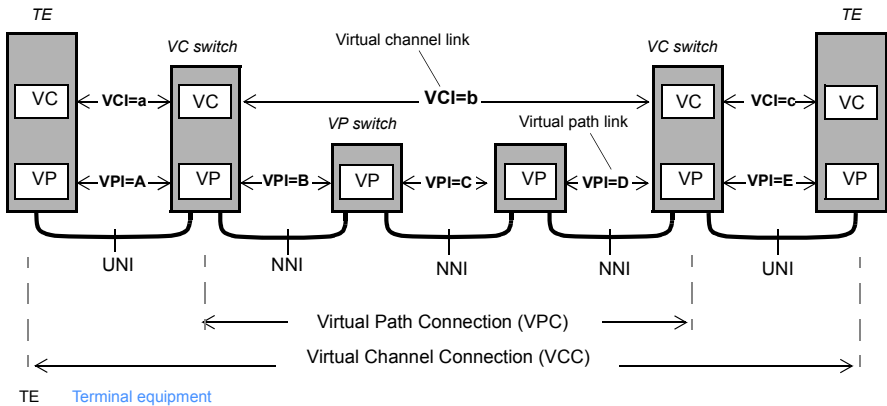

Figure 5 Virtual channel connection and virtual path connection

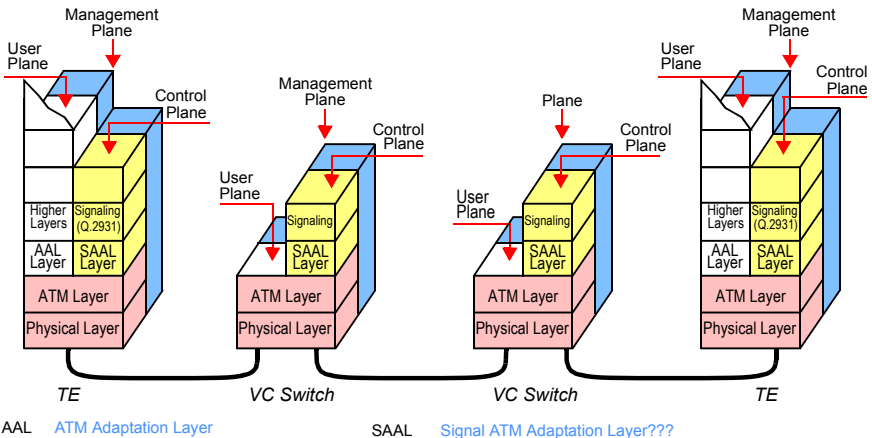

Figure 6 Layers and planes implemented in terminal equipment (TE) and switches

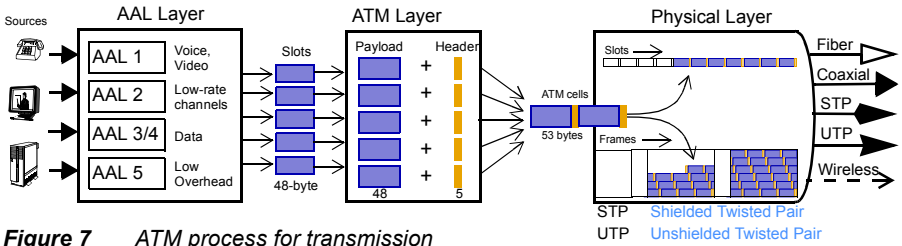

Figure 7 ATM process for transmission

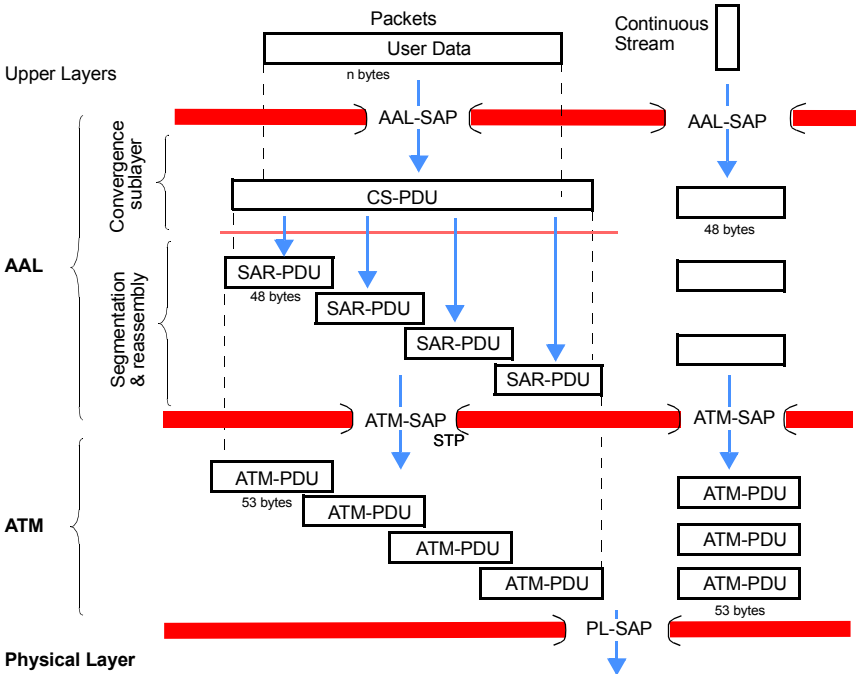

Figure 8 Protocol Data Unit (PDU) exchange between ATM layers

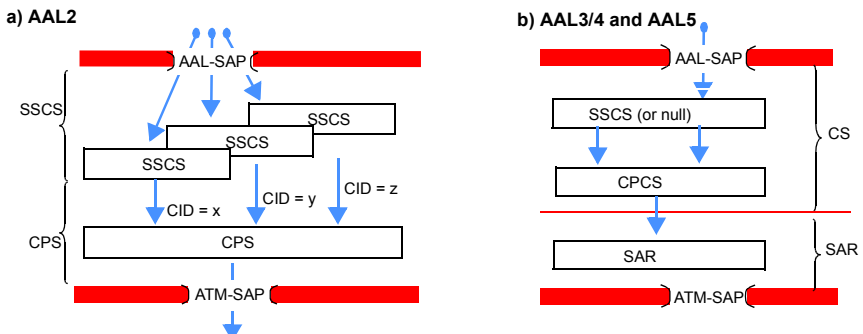

Figure 9 a) Multiplexing many channels (CIDs) in one ATM connection (AAL2 only)
b) Multiplexing structure for AAL3/4 and AAL5

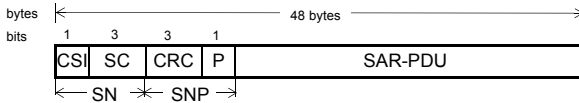

Figure 10 AAL1 structure

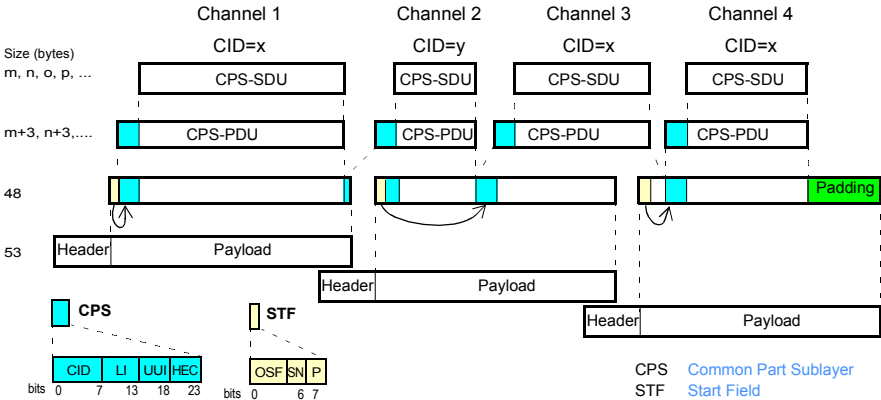

Figure 11 AAL2 format

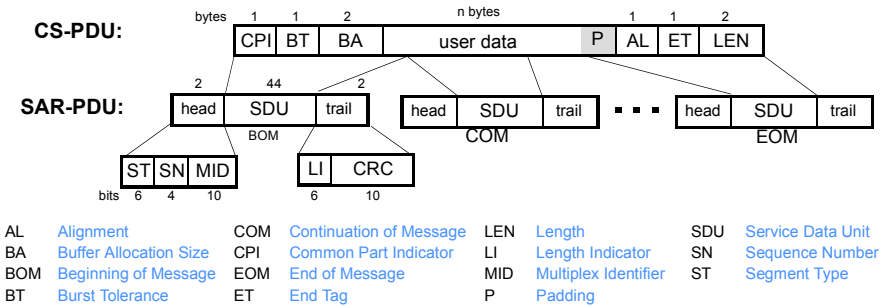

Figure 12 AAL3/4 format

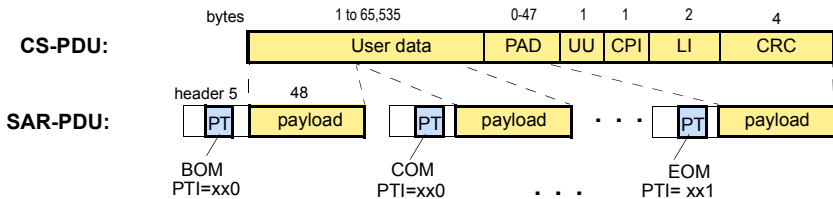

Figure 13 AAL5 format

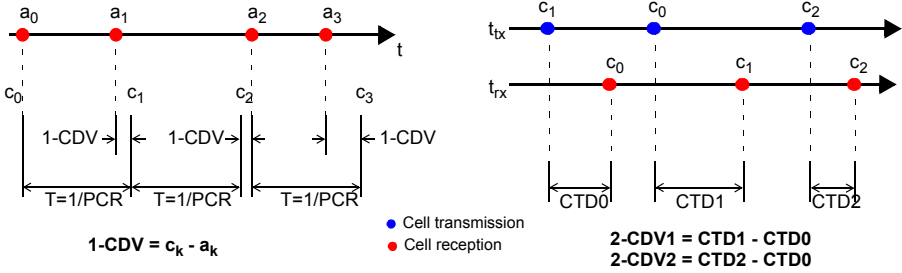

Figure 14 Representation of the 1-CDV and 2-CDV parameters

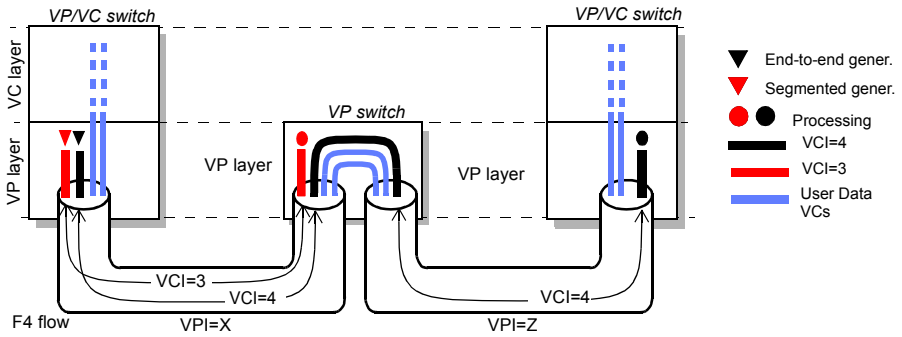

Figure 15 End-to-end and segmented F4 flows in a supervised VPC

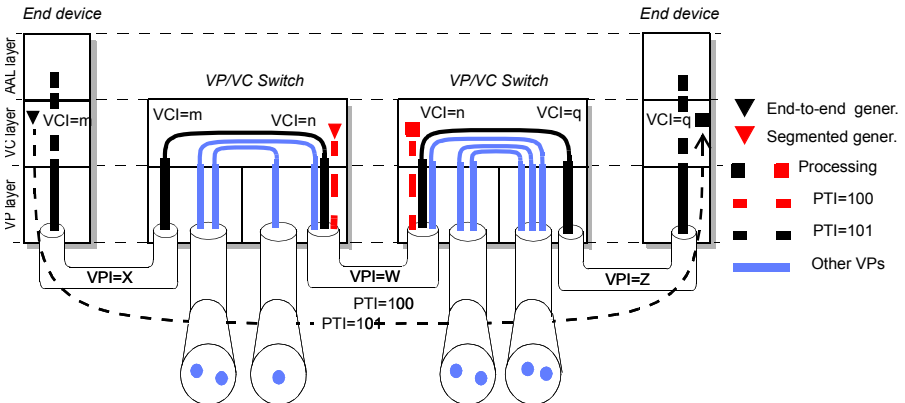

Figure 16 End-to-end and segmented F5 flows transmitted across the monitored VCC

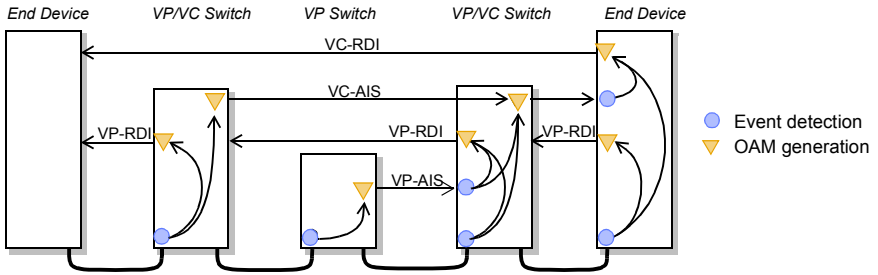

Figure 17 Generating VP-AIS/RDI and VC-AIS/RDI type OAM cells

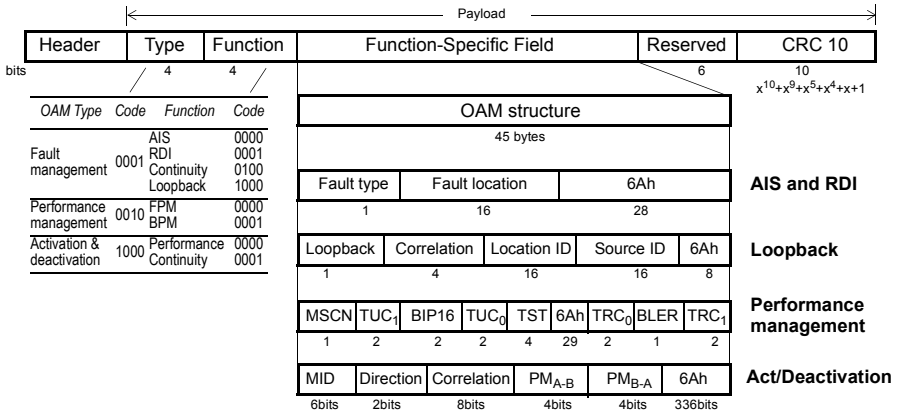

Figure 18 Format of OAM cells

Figure 19 Format of an O.191 test cell

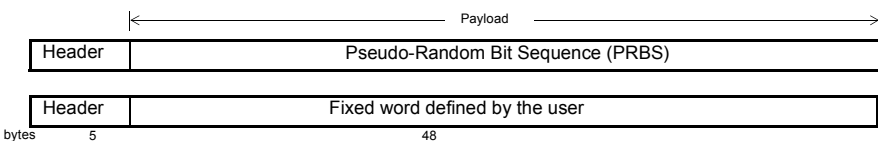

Figure 20 Test cell format to measure BER

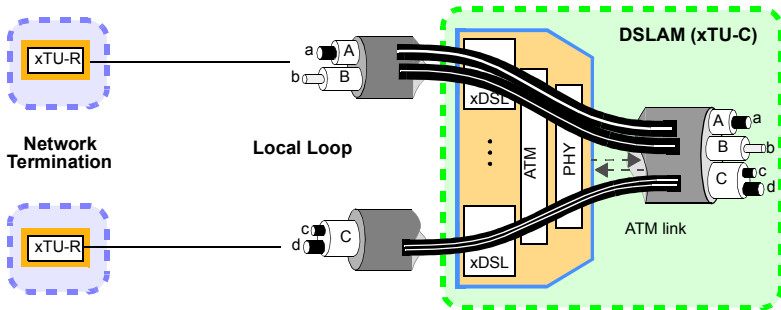

Figure 21 Multiplexing ATM in the DSLAM

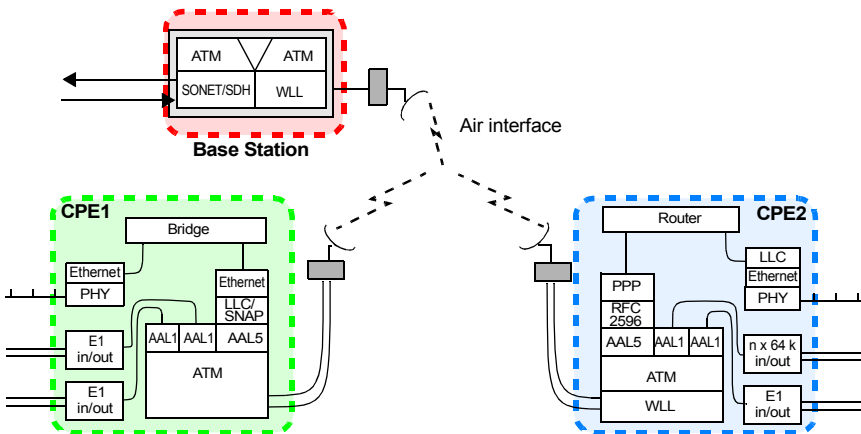

Figure 22 Structure and protocols for WLL network elements

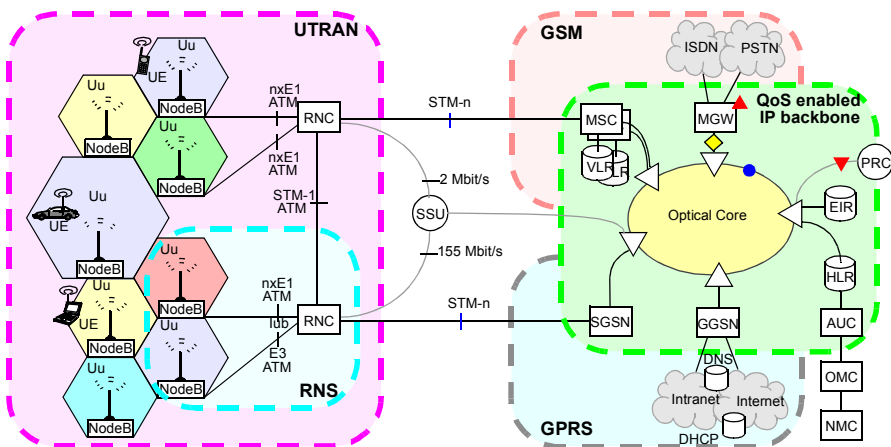

Figure 23 UMTS/3G architecture

Acronyms

1-CDV	One point Cell Delay Variation	PM	Performance Monitoring
2-CDV	Two point Cell Delay Variation	PNNI	Private Network-Network Interface
AAL	ATM Adaption Layer, can be divided into CS and SAR	PTI	Payload Type Indicator - 0xx: user data, x0x: No congestion; x1x: Congestion; xx0: BOM, xx1:EOM
ATM	Asynchronous Transfer Mode	PVC	Permanent Virtual Circuit
BIP	Bit Interleaved Parity	QoS	Quality of Service
BLER	Block Error Result	RNC	Radio Network Controller
CID	Channel Identifier	RNS	Radio Network Subsystem
CLP	Cell Loss Priority	SAP	Service Access Point
CPCS	Common Part CS	SAR	Segmentation and Reassembly
CPI	Common Part Indicator	SC	Sequence count.
CPS	Common Part Sublayer	SDU	Service Data Unit
CS	Convergence Sublayer, can be divided into SSSC and CPCS	SN	Sequence Number
CSI	Convergence Sublayer Indicator	SNAP	Subnetwork Access Protocol
CTD	Cell Transfer Delay	SNP	Sequence Number Protection
E2E	End to End	SSCS	Service Specific CS
GFC	Generic Flow Control	SSU	
GPRS	General Packet Radio Service	STF	Start Field
HEC	Header Error Control	SVC	Switched Virtual Connection
ILMI	Interim Local Management Interface	TRC	Total Received Cell Count
LI	Length Indicator	TST	Time Stamp
LLC	Logical Link Control	TUC	Total User Cell Number
MID	Message Identifier	UNI	User-Network Interface
MSCN	Monitoring Cell Sequence Number	UTRAN	Universal Mobile Telecommunications System
NNI	Network-to-Network Interface	UUI	User-to-User Indication
OAM	Operation, Administration, and Maintenance	VCC	Virtual Channel Connection
OSF	Operation System Function	VCI	Virtual Channel Identifier
P2P	Point to point	VPC	Virtual Path Connection
PAD or p	Padding PAD Padding used to cell align	VPI	Virtual Path Identifier
PCR	Peak Cell Rate	WLL	Wireless Local Loop
PDU	Protocol Data Unit		



Trend Communications Ltd.
Knaves Beech Estate
Loudwater, High Wycombe
Buckinghamshire HP10 9QZ UK

Trend Communications

Americas: +1 256 461 0790
Deutschland: 089 32 3009-0
España: 93 300 33 13
France: 01 69 35 54 70
India: 22 8597 463/4
UK: 01628 524977

web: www.trendcomms.com
mail: info@trendcomms.com



More information in:

Installation and Maintenance of SDH/SONET, ATM, XDSL, and Synchronization Networks.

2003 (c) Artech House, ISBN:1580535259