



INTERNATIONAL TELECOMMUNICATION UNION

ITU-T

TELECOMMUNICATION
STANDARDIZATION SECTOR
OF ITU

Z.335

MAN-MACHINE LANGUAGE

ROUTING ADMINISTRATION

ITU-T Recommendation Z.335

(Extract from the *Blue Book*)

NOTES

1 ITU-T Recommendation Z.335 was published in Fascicle X.7 of the *Blue Book*. This file is an extract from the *Blue Book*. While the presentation and layout of the text might be slightly different from the *Blue Book* version, the contents of the file are identical to the *Blue Book* version and copyright conditions remain unchanged (see below).

2 In this Recommendation, the expression “Administration” is used for conciseness to indicate both a telecommunication administration and a recognized operating agency.

Recommendation Z.335

ROUTING ADMINISTRATION

1 General

This Recommendation has been developed in accordance to the methodology defined in Recommendations Z.332 and Z.333.

The main part of this Recommendation deals with the model of routing administration and glossary of the terms used is also included.

The list of operator jobs and the list of system functions to be controlled are contained in annex A.

For each system function to be controlled by means of MML, one or more MML functions can be derived and each of them can be described using the metalanguage defined in Recommendation Z.333, in order to detail the relevant information structure.

Annex B contains a list of MML functions and information structure diagrams associated to each of them to be used as guidelines.

2 Introduction

The routing functions are those system functions that are in charge of routing a call attempt toward its destination on the basis of the data associated with the call attempt (e.g. the dialled digits, etc.) and the data associated to the network (e.g. identities of the circuit sub-groups serving a certain destination, etc.). The destination of a call attempt may be inside the switching system as well as outside the switching system. If the destination is inside the switching systems, the routing will consist of identifying the termination that corresponds to the destination. If the destination is outside the switching system the routing functions shall search for a free circuit, within a given circuit sub-group on which the call attempt will be routed.

Routing consists of functions whose parameters may vary with the network design and the switching system design to fit the network application. The economics of a switching system in a network application is, in part, a function of how well the routing functions match the network design.

The main activities for creating and maintaining routing administration data may be summarized by the following items:

- analysis of the data provided by the traffic measurement functions;
- defining the routing strategies on the basis of the achieved results;
- creating new or changing the existing items, related to the routing in the switching systems, in order to satisfy the routing strategies.

Only the last of these items is within the scope of this Recommendation.

This Recommendation deals with the routing administration functions involved with the routing towards destinations outside the switching system, whichever signalling system is used.

3 Routing administration model

3.1 Introduction

To service a call in order to make it proceed towards the desired called party, two steps are pointed out:

- the identification of the destination of the call made by means of the analysis of the selection digits and by means of other information;
- the selection of a free circuit within a set of suitable circuits on which the call may be forwarded.

The routing functions provided by a system deal mainly with the second step and the present Recommendation relates to their administration. In this section a model for the administration of routing functions is reported, describing the information used.

Figure 1/Z.335 provides a description of the connections that exist at the man-machine interface, among the routing items (such as circuits, circuit sub-groups, routes and route groups) that can be administered by means of MML functions.

The purpose of this model is to provide an overview of the routing items and the relevant parameters. No specific association between parameters and routing items is intended other than for explanatory purposes. Any parameter can be associated to any routing item depending on the specific needs of an administration or of the network: for example, the type of signalling system may be determined at route group, route or circuit sub-group level, without changing its function.

The collection of combinations of destination and additional parameters forms the routing table, which contains all the possibilities of routing for a given system. One entry in this table is called routing table element.

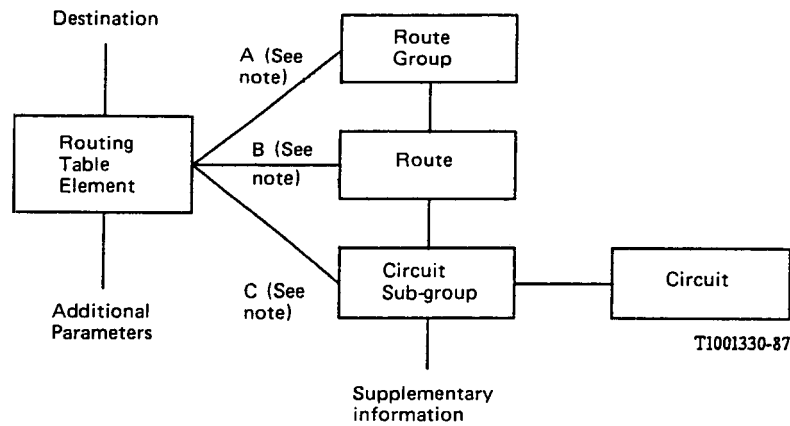

Note – Option A = The model comprises route groups, routes and circuit sub-groups.

Option B = The model comprises routes and circuit sub-groups.

Option C = The model comprises circuit sub-groups only.

These options are to be considered, on an equal footing, as complete models of equal acceptability. Even though route groups and routes can be implicitly present in the routing table, they do not necessarily appear explicitly in the man-machine interface.

FIGURE 1/Z.335

Routing administration model

3.2 Parameters

The parameters used in the decision process of routing a call are included in the following list. In Figure 1/Z.335 they are represented by destination, additional parameters and supplementary information. The list is open-ended and not all the parameters are needed for all applications. The list may vary according to administration needs, telecommunication network levels, etc.

The methods used to evaluate these parameters within the switching system should not be constrained by the model.

- 1) Destination;
- 2) Class of incoming circuit sub-group;
- 3) Calling party category;
- 4) Parameters for network management (e.g. time of day, presence of carrier failure, etc.);
- 5) Signalling system (incoming and outgoing);
- 6) Transmission characteristics (incoming and outgoing);
- 7) Circuit type (e.g. two wires, four wires);
- 8) Presence of echo canceller;
- 9) Transmission medium characteristics (i.e. presence of satellite links);
- 10) Selection of specific carrier or specific network.

The destination is identified by means of the selection digits on the basis of the incoming route (origin information) or signalled information.

The additional parameters are those parameters that allow identification of the possible choices for routing a call towards a given destination. The following factors may be used as additional parameters (the list is neither mandatory nor complete):

- a) Class of incoming circuit sub-group;
- b) Calling party category;
- c) Parameters for network management.

A combination of destination and additional parameters identify a routing table element which contains all the possibilities to set up a call in order to forward it.

3.3 *Route group*

A route group consists of one or more routes that may be used for a given destination. A route group may be accessed by more than one combination of destination and additional parameters.

3.4 *Route*

A route consists of one or more circuit sub-groups and of some information associated with the route describing the use of the route itself.

Examples of this information may be:

- seizure signal to send (terminal, transit);
- number of digits to send;
- digits to add.

If the route is not present in the routing administration model the information should be associated to other routing items.

3.5 *Circuit sub-group*

A circuit sub-group is a set of circuits between two exchanges. In options A and B, circuits within a circuit sub-group have similar characteristics (e.g. type of signalling, type of transmission path, etc.).

The selection of a given circuit sub-group inside a route can be made on the basis of supplementary information such as signalling system, transmission technique, circuit type (e.g. two wires, four wires), presence of echo canceller, transmission medium characteristics (e.g. presence of satellite links), etc. Other information may also be associated to circuit sub-groups; examples of this information are:

- traffic direction;
- class of incoming circuit sub-group;
- search method to select a circuit inside the sub-group.

3.6 *Circuit*

A circuit is characterized by an identity, by its hardware termination identity and by its sequence number inside the circuit sub-group (this latter is only used for selection purposes in outgoing circuit sub-groups). If common channel signalling is used, a label should be assigned to the circuit.

4 Additional information

4.1 *Management of the status of routing items*

In order to change the routing capabilities of the telecommunication systems, facilities are required to alter the operating status of the items involved (i.e. to put a circuit in service or out of service, etc.).

This topic is left for further study.

4.2 *Reliability mechanisms*

In order to prevent malfunctions and errors when servicing a call, the routing administration functions used in the telecommunication system must implement reliability mechanisms. The most critical functions, e.g. change functions, should not be provided to the operator if reliability mechanisms are not provided.

The selection and implementation of reliability mechanisms are not covered in this Recommendation.

However, due to the fact that the mechanism used may affect the man-machine interface, it is highlighted that such aspect should be studied and taken into account when designing the real man-machine interface.

5 Glossary of used terms

circuit

Connection between two exchanges for one call at a time, including the junctors that terminate the circuit.

circuit sub-group

Group of circuits between two exchanges having the same traffic direction (incoming, outgoing, bidirectional), the same signalling characteristics and the same transmission medium characteristics.

route

Collection of circuit sub-groups between two exchanges that are equivalent for routing purposes. The term route is equivalent to the concept of "circuit group" as used in Recommendation Z.337 and in E-Series Recommendations.

route group

The set of all the possible routes on which a call may be forwarded to the appropriate destination.

ANNEX A

(to Recommendation Z.335)

List of system functions to be controlled by MML and list of jobs

A.1 *List of system functions to be controlled by MML*

- 1) Managing the routing data base
- 2) Querying the routing data base

A.2 *List of jobs*

- 1) To create/change items involved in the routing functions or change old ones (e.g. circuit sub-groups, routes, etc.)
 - the purpose of the job is to create and/or change the configuration of the switching system regarding the items involved in the routing of a call;
 - the system is supposed to record the new data and to check their static correctness;
 - the operator is supposed to input all needed data;
 - the complexity of the job may be high depending on the amount of the data to be input for the item to be created/changed;
 - the frequency of the job is medium;
 - the job is supposed to be performed at exchange and/or OMC level.
- 2) To delete items related to the routing
 - the purpose of the job is to delete items no longer useful;
 - the system is supposed to delete the specified items deleting the related data only if no call is currently routed on the item;
 - the operator is supposed to introduce the identity of the item to be deleted;
 - the complexity of the job is low (if the system makes sufficient checks);

- the frequency of the job is low;
 - the job is supposed to be performed at exchange and/or OMC level.
- 3) To interrogate different kinds of information related to the routing
- the purpose of the job is to get information on the current data used by the system to perform the routing;
 - the system is supposed to output the information requested in suitable formats and on the selected devices;
 - the operator is supposed to input the identity of the item to be interrogated and to select the information to be retrieved;
 - the complexity of the job is low;
 - the frequency of the job is high;
 - the job is supposed to be performed at exchange and/or OMC level.

ANNEX B

(to Recommendation Z.335)

Guidelines for the list of MML functions and associated information structure diagrams

B.1 *Introduction*

This annex contains guidelines for the list of MML functions and associated information structure diagrams related to the routing administration model defined in Recommendation Z.335, § 3.

B.2 *List of MML functions*

This list contains possible MML functions for routing administration.

This list is not mandatory nor complete, it may vary according to administration needs, telecommunication network levels, regulatory needs, etc.

These MML functions do not represent the actual command structure of any real implementation of the man-machine interface. Each of the MML functions identified can be implemented by providing one or more separate distinctive commands or several MML functions could be implemented by using a single command.

1) *Creation*

- create a circuit,
- create a circuit sub-group,
- create a route (only options A and B)¹⁾,
- create a route group (only option A)¹⁾,
- create a destination.

2) *Deletion*

- delete a circuit,
- delete a circuit sub-group,

¹⁾ Options A and B are defined in Recommendation Z.335, § 3.

- delete a route (only options A and B)²⁾,
- delete a route group (only option A)²⁾,
- delete a destination.

3) *Interrogation*

- interrogate a circuit,
- interrogate a circuit sub-group,
- interrogate a route (only options A and B)²⁾,
- interrogate a route group (only option A)²⁾,
- interrogate a destination.

4) *Changing*

- change a circuit,
- change a circuit sub-group,
- change a route (only options A and B)²⁾,
- change a route group (only option A)²⁾,
- change a destination.

B.3 *Information structure diagrams*

Only the information entities needed for the MML functions previously derived have been identified. They are reported in this section by means of diagrams representing each MML function information structure.

These diagrams represent typical routing function requirements. They are not intended to constrain in any way the enhancement of these functions in the light of technological advances or specific administration or regulatory requirements.

The metalanguage used is described in Recommendation Z.333.

²⁾ Options A and B are defined in Recommendation Z.335, § 3.

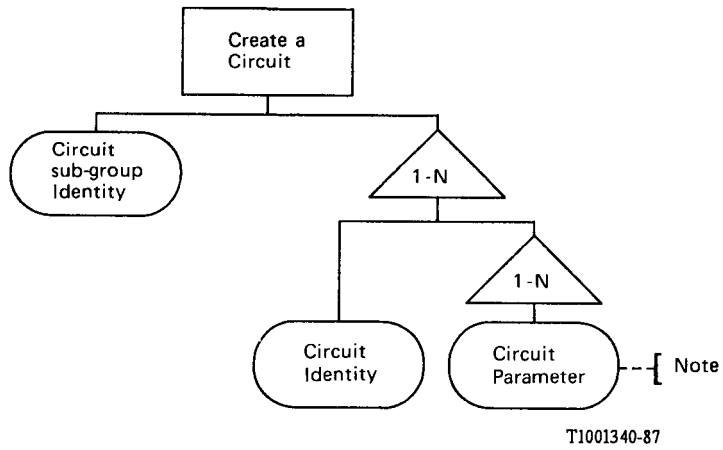

Note – Possible parameters are:
 – HW terminal identity.
 – Sequence number.
 – Common channel signalling label.

FIGURE B-1/Z.335
Create a circuit

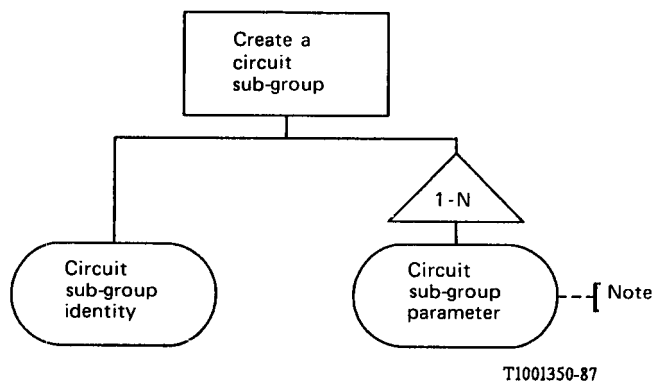

Note – Possible parameters are:
 – Signalling system.
 – Traffic direction.
 – Circuit type.
 – Transmission technique.
 – Presence of echo canceller.
 – Transmission medium characteristics.
 – Class of incoming circuit sub-group.

FIGURE B-2/Z.335
Create a circuit sub-group

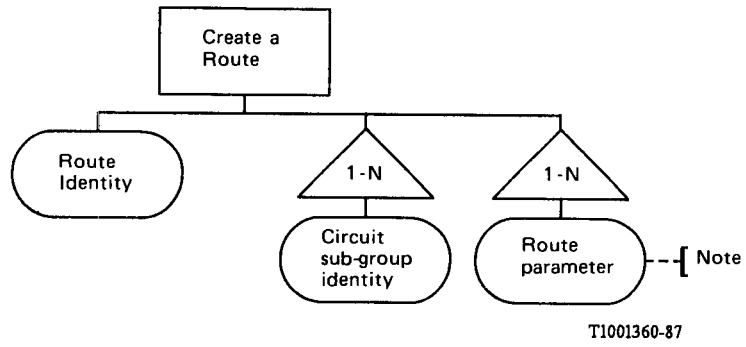

Note – Possible parameters are:
 – Type of seizure to send.
 – Digits to be added.
 – Number of digits to suppress.
 – Search method.

FIGURE B-3/Z.335
Create a route

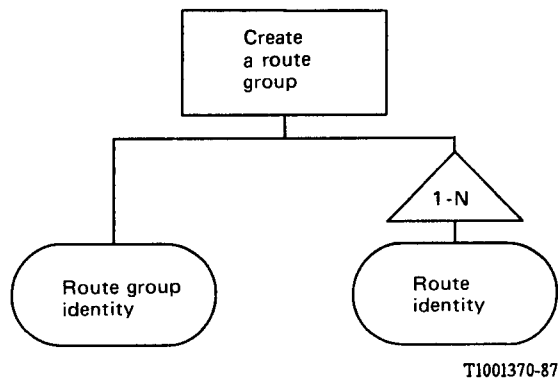
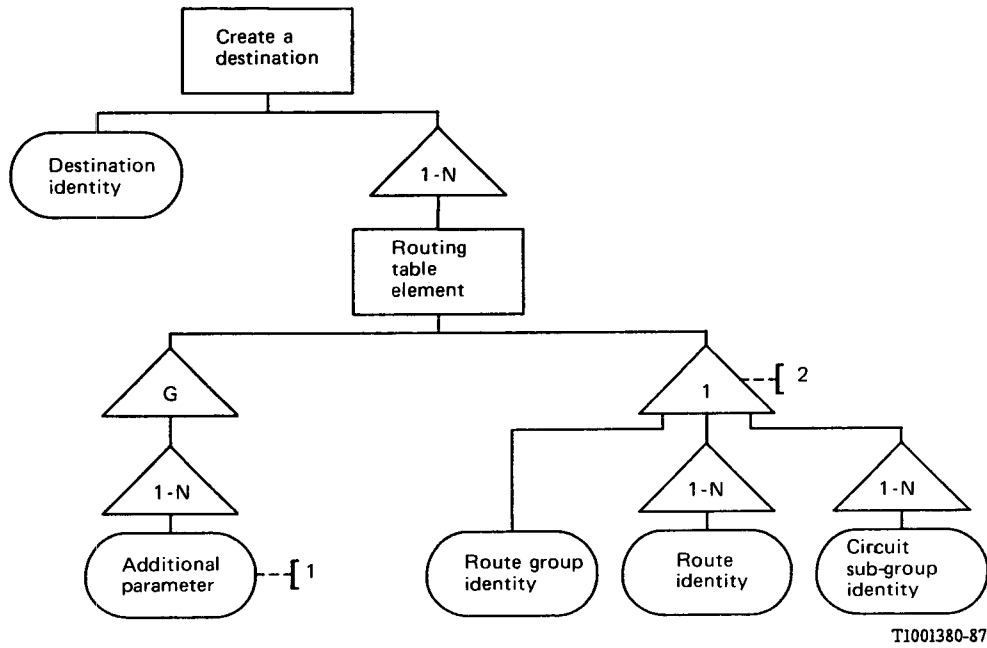

FIGURE B-4/Z.335
Create a route group



Note 1 – Possible parameters are:
 – Calling party category.
 – Class of incoming circuit group.
 – Parameters for network management.

Note 2 – The selection is made according to the option (A, B or C) adopted.

FIGURE B-5/Z.335
Create a destination

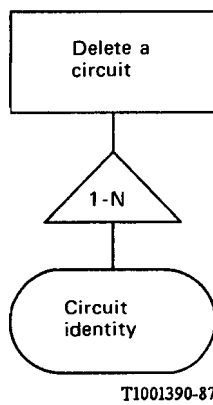

FIGURE B-6/Z.335
Delete a circuit

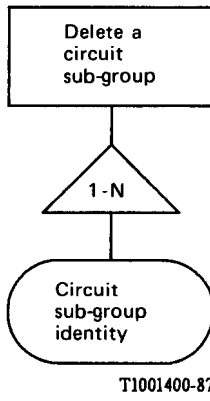
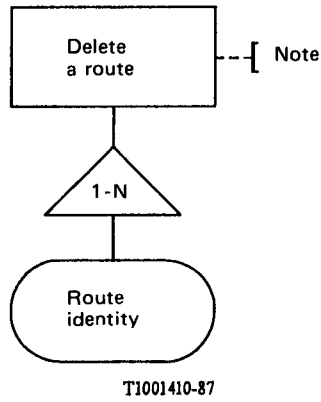
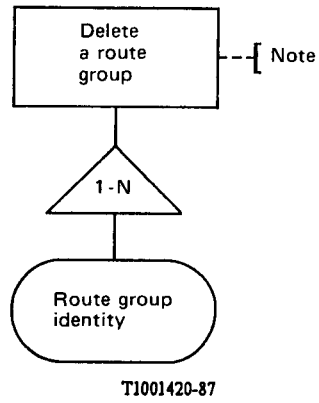

FIGURE B-7/Z.335
Delete a circuit sub-group



Note — Only required in option A and B.

FIGURE B-8/Z.335
Delete a route



Note – Only required in option A.

FIGURE B-9/Z.335
Delete a route group

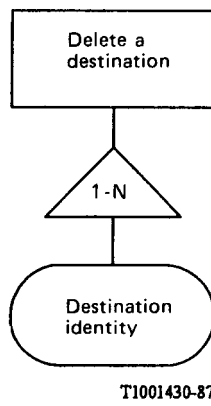
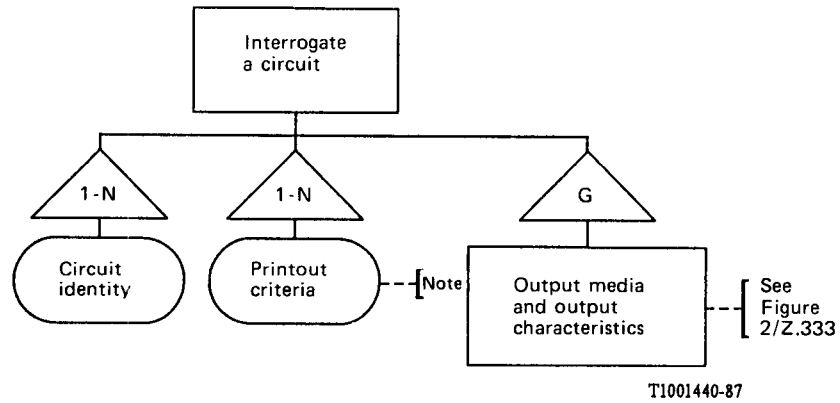

FIGURE B-10/Z.335
Delete a destination



- Note* – Possible values:
- Status.
 - HW termination identity.
 - Sequence number.
 - Circuit sub-group owning the circuit.

FIGURE B-11/Z.335

Interrogate a circuit

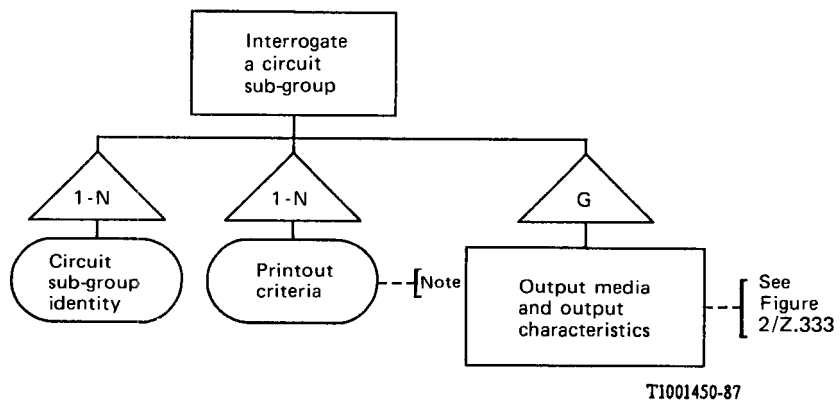

- Note* – Possible values:
- Circuit identities.
 - Signalling system.
 - Traffic direction.
 - Transmission medium characteristics.
 - Transmission technique.
 - Presence of echo canceller.
 - Circuit type.
 - Search method.
 - Routes owning the circuit sub-group.

FIGURE B-12/Z.335

Interrogate a circuit sub-group

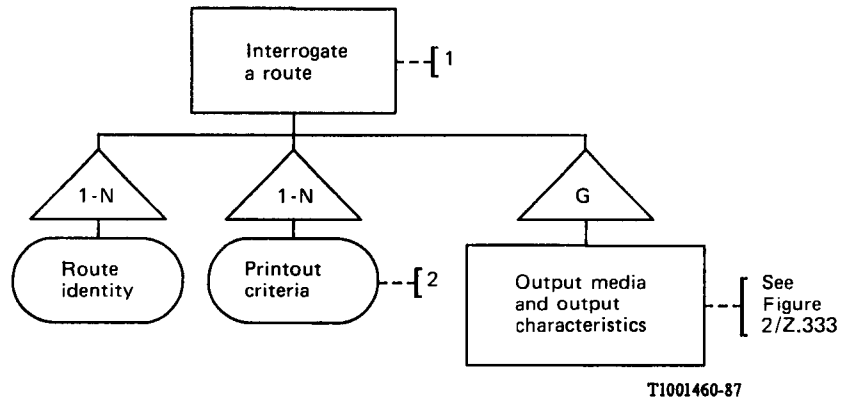

Note 1 – Only required in options A and B.

Note 2 – Possible values:

- Circuit sub-groups.
- Circuit sub-groups sequence.
- Traffic direction.
- Route group owning the route (only option A).
- Type of seizure and digits to add (only incoming).
- Type of seizure, digits to add or to suppress (only option B).
- Destinations vs additional parameters associated to route (only option B).

FIGURE B-13/Z.335

Interrogate a route

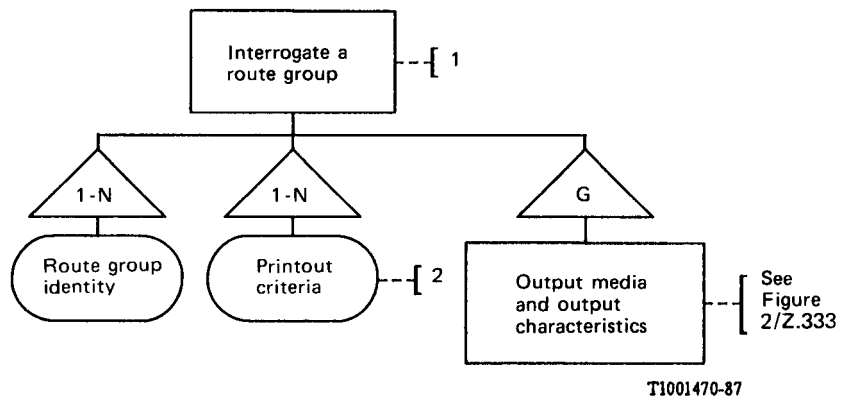

Note 1 – Only required in option A.

Note 2 – Possible values:

- Route identities.
- Destinations owning the route group.
- Destinations vs additional parameters.

FIGURE B-14/Z.335

Interrogate a route group

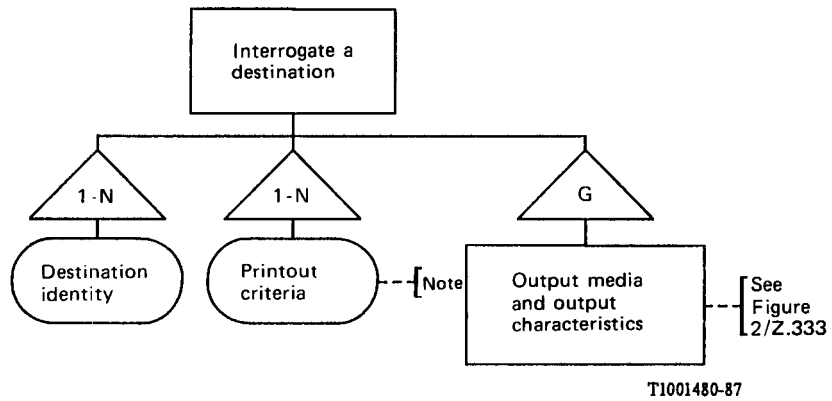

- Note* – Possible values:
- Route groups (option A).
 - Route groups vs additional parameters (option A).
 - Routes (option B).
 - Routes vs additional parameters (option B).
 - Circuit sub-groups (option C).
 - Circuit sub-groups vs additional parameters (option C).

FIGURE B-15/Z.335
Interrogate a destination

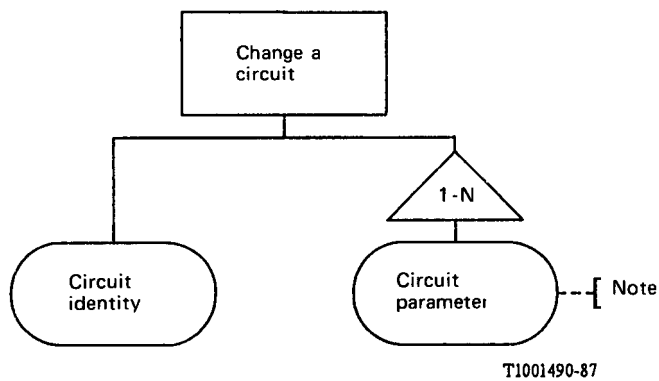

- Note* – Possible parameters are:
- HW terminal identity.
 - Sequence number.
 - Common channel signalling label.

FIGURE B-16/Z.335
Change a circuit

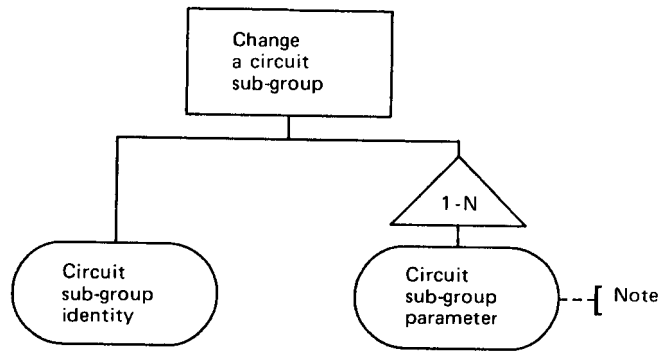

T1001500-87

- Note* – Possible parameters are:
- Signalling system.
 - Traffic direction.
 - Circuit type.
 - Transmission technique.
 - Presence of echo canceller.
 - Transmission medium characteristics.
 - Class of incoming circuit sub-group.

FIGURE B-17/Z.335

Change a circuit group

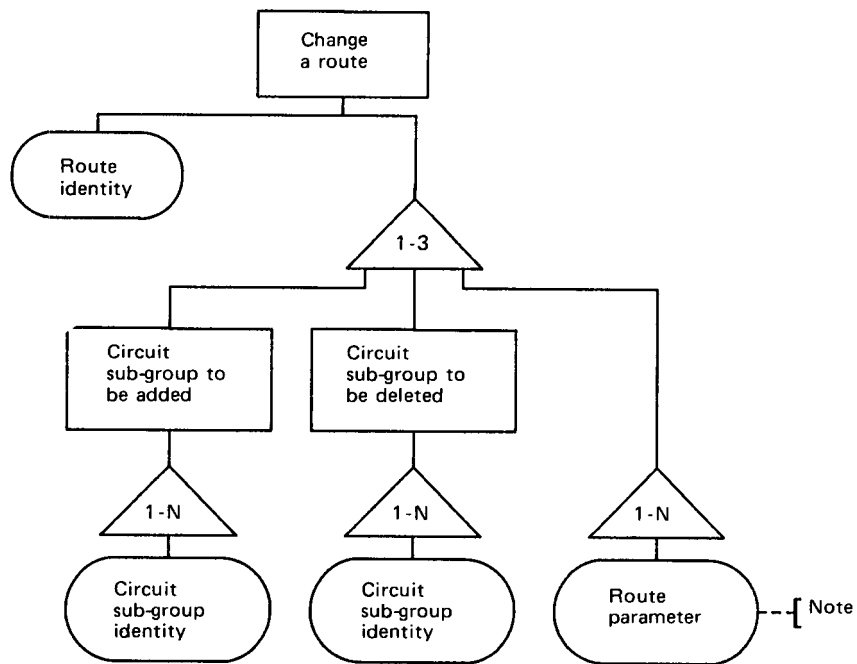

T1001510-87

- Note* – Possible parameters are:
- Type of seizure to send.
 - Digits to be added.
 - Number of digits to suppress.
 - Search method.

FIGURE B-18/Z.335

Change a route

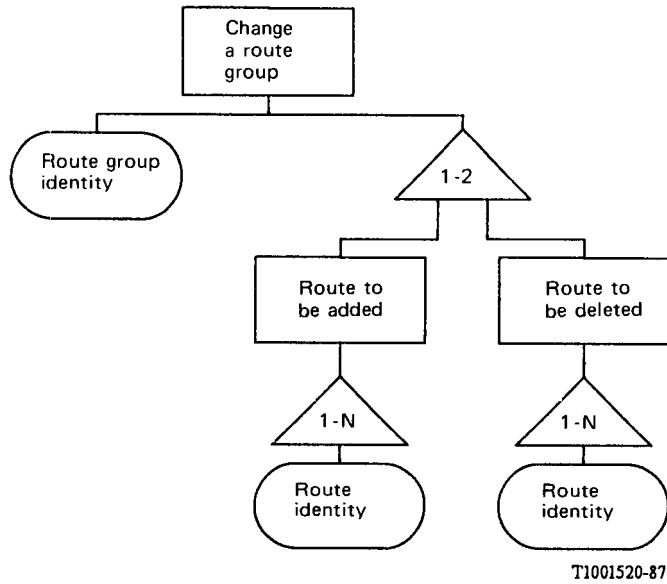
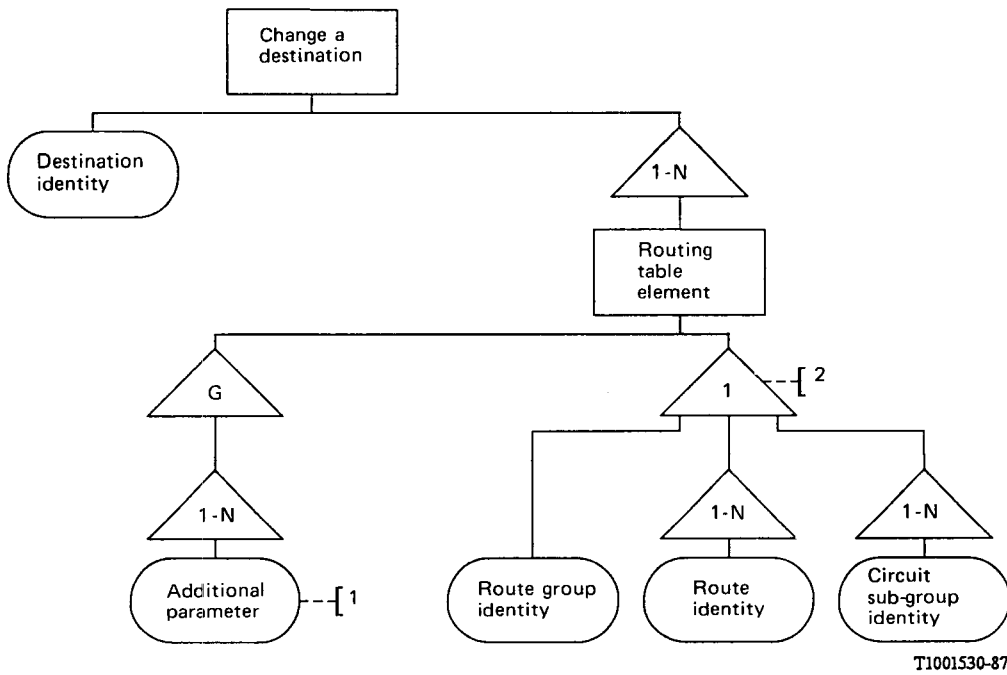

FIGURE B-19/Z.335

Change a route group



- Note 1* – Possible parameters are:
- Calling party category.
 - Class of incoming circuit sub-group.
 - Parameters for network management.

Note 2 – The selection is made according to the option (A, B or C) adopted.

FIGURE B-20/Z.335

Change a destination