



INTERNATIONAL TELECOMMUNICATION UNION

CCITT

THE INTERNATIONAL
TELEGRAPH AND TELEPHONE
CONSULTATIVE COMMITTEE

M.3602

(10/92)

MAINTENANCE: ISDN

**APPLICATION OF MAINTENANCE
PRINCIPLES TO ISDN
SUBSCRIBER INSTALLATIONS**



Recommendation M.3602

FOREWORD

The CCITT (the International Telegraph and Telephone Consultative Committee) is a permanent organ of the International Telecommunication Union (ITU). CCITT is responsible for studying technical, operating and tariff questions and issuing Recommendations on them with a view to standardizing telecommunications on a worldwide basis.

The Plenary Assembly of CCITT which meets every four years, establishes the topics for study and approves Recommendations prepared by its Study Groups. The approval of Recommendations by the members of CCITT between Plenary Assemblies is covered by the procedure laid down in CCITT Resolution No. 2 (Melbourne, 1988).

Recommendation M.3602 was revised by Study Group IV and was approved under the Resolution No. 2 procedure on the 5th of October 1992.

CCITT NOTE

In this Recommendation, the expression "Administration" is used for conciseness to indicate both a telecommunication administration and a recognized private operating agency.

© ITU 1993

All rights reserved. No part of this publication may be reproduced or utilized in any form or by any means, electronic or mechanical, including photocopying and microfilm, without permission in writing from the ITU.

Recommendation M.3602

APPLICATION OF MAINTENANCE PRINCIPLES TO ISDN SUBSCRIBER INSTALLATIONS

(Melbourne 1988 as Rec. I.602; revised and renumbered in 1992)

Abstract

This Recommendation defines physical layer maintenance functions used to maintain ISDN subscriber installations.

Keywords

- ISDN;
- maintenance;
- subscriber installation.

1 Scope of application

This Recommendation presents the possible elementary functions for the maintenance of the subscriber installation. The functions are to be considered as optional, except when needed to meet specific network interface requirements found in Recommendations I.430 [3] and I.431 [4].

These functions can be controlled by the local side, (e.g. from the subscriber premises) and by a remote side (i.e. from a Management Service Provider¹⁾ (MSP) as described in Recommendation M.3600 [1]].

It is the responsibility of the subscriber installation to ensure that only authorized MSPs are given access to the functions covered by this Recommendation.

2 Network configuration for maintenance activities

Figure 1/M.3602 is the basis for the general maintenance principles of the ISDN subscriber installation.

There are several subscriber configurations using primary rate shown in Figure 2/M.3602 that can appear behind any of the NT1s shown in Figure 2/M.3604 [6]. The first is the simplest case of separate NT1 and NT2 followed by a primary rate TE. Another case is with the NT1 and NT2 combined into one unit. A third case is an NT2 that is a PABX with several basic rate TEs behind it. A final case is one in which the NT2 is a multiplexer with several basic rate TEs behind it.

3 Automatic supervision

3.1 *Continuous automatic supervision on layer 1*

3.1.1 *General*

This supervision may be realized by permanent automatic mechanisms located in the pieces of equipment of the subscriber installation (see definition in Figure 1/M.3602). These automatic mechanisms are operational during the active period of the subscriber basis access. They are designed to detect malfunctioning of particular items, e.g. power supply, quality level of transmission, incoming signal, frame alignment.

¹⁾ This Recommendation deals only with the maintenance aspects of management.

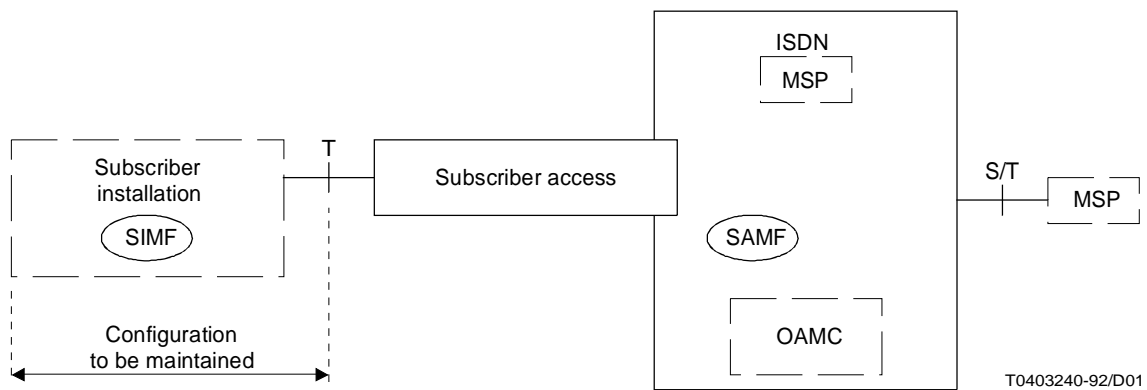

MSP Management Service Provider
 OAMC Operation Administration Maintenance Centre
 SAMF Subscriber Access Management Function
 SIMF Subscriber Installation Management Function

See Recommendation M.3600 [1] for a detailed discussion of these terms.

Note – In some countries, certain maintenance functions within the subscriber access are controlled by the subscriber installation (SIMF).

FIGURE 1/M.3602
Configuration for the maintenance of the subscriber installation

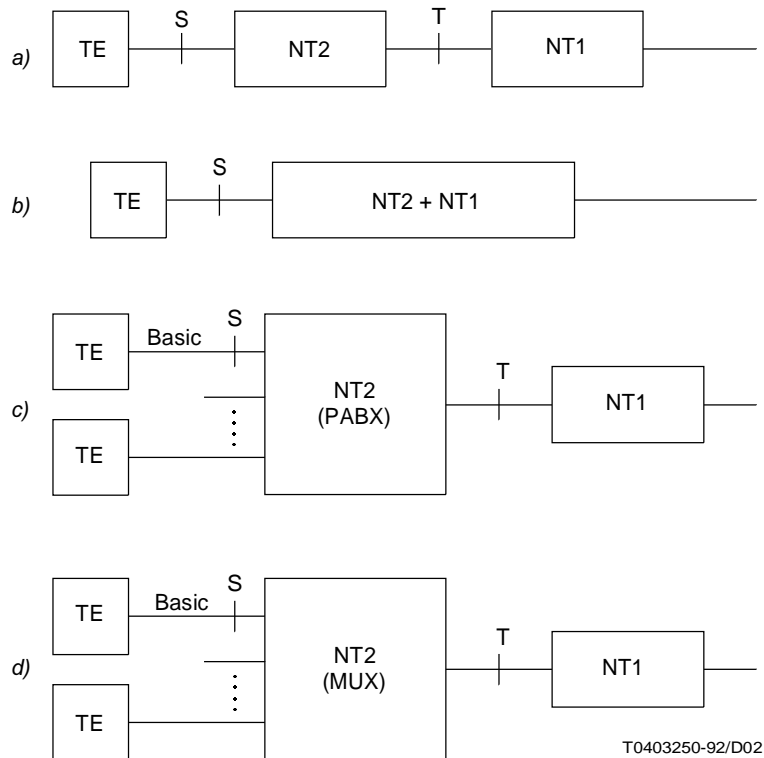

FIGURE 2/M.3602
Primary rate subscriber configuration examples

3.1.2 *Subscriber installation functions*

The following functions may be supervised:

- monitoring of operation functions within the subscriber installation (e.g. power supply);
- supervision of information related to or received from the digital transmission section.

3.2 *Automatic supervision on layer 2 and layer 3 of the D-channel protocol*

This activity covers supervision on layers 2 and 3 of the D-channel protocol. Automatic supervision on layers 2 and 3 may be made by self-acting mechanisms implemented in the subscriber installation.

There are three categories of automatic supervision which may be performed by layer 2 and layer 3 of the D-channel protocol:

- service provision incapability detection (e.g. detection of incapability of layer 2 to establish a data link connection);
- protocol misoperation detection;
- error monitoring (e.g. layer 2 CRC check procedure can detect the occurrence of an errored frame).

These events may be recorded as discussed in Recommendation M.3640 [2].

4 Internal tests

4.1 *Internal test of the TE1 and TA*

Some of the TEs/TAs may manage internal tests for all or parts of their functionalities. The internal tests may be activated either automatically by the TE and TAs or by a local command in the TE and TAs or by a remote request.

Some of these tests are dependent on the terminal type. Such tests shall not affect the user-network interface, i.e. no test signals shall be transmitted across the interface when a test is in operation.

The terminal equipment may have the ability to abort an internal test sequence, for example, in case of an incoming call attempt. If this test has been requested by an MSP, the subscriber installation should report the discontinuance of the test to the requesting MSP.

The result of an internal test procedure execution should be either **passed** or **failed**, and in the latter case an additional diagnostic information may be given.

4.2 *Internal test of the NT2*

The subscriber should have facilities which can help to verify that the subscriber installation is not affected by a fault. Definitions of these procedures and functions require further study. The functionalities may be similar to the ones presented for the TE and TA in § 4.1.

The following internal tests of the NT2 have been identified:

4.2.1 *Continuity test*

The objective is to verify that the internal S interfaces of the NT2 can be activated. The mechanism which is implemented in the NT2 could be based on a normal activation of the layer 1 of the interfaces.

The principle for such a test is the same as the one defined for the local exchange function (see Recommendation M.3603 [5], § 3.3).

4.2.2 *S interface check using loopback 3*

The loopbacks are shown in § 7. The results could be used for fault localization, particularly in the case where the NT2 functions are distributed.

4.2.3 *Test call to the terminal equipment from the NT2*

An NT2 may address one particular terminal equipment of the installation. Thus, it easily controls a test call. This procedure would allow the NT2 to verify the connection of the TE or TA to the installation and also to check layers 1, 2 and 3 operating conditions (e.g. response time supervision).

The test call could be initiated by the SIMF at the request of an MSP.

The test call could be a normal call made for maintenance purposes.

4.3 *Basic rate subscriber installation functions using S- and Q-channels*

The S- and Q-channels of the T interface (see Recommendation I.430 [3]) may be used to perform functions supporting failure detection and fault location. These functions can be grouped into four major areas.

4.3.1 *Loss of power indication*

The NT1 or NT2 may use the S-channel to indicate a loss of power and the TE may use the Q-channel to indicate a loss of power. The use of these indications on interfaces using the activation/deactivation procedure is for further study.

4.3.2 *Self-test functions*

The Q-channel may be used to request an NT1 or NT2 to perform a self-test. The S-channel may be used to indicate that the self-test is being performed and to indicate whether the test passed or failed.

4.3.3 *Loopback control*

The Q-channel may be used to control loopbacks C in the NT1s or loopbacks B₁ in NT2s. The S-channel may be used by the NT1 or NT2 to indicate that the loopback is active.

4.3.4 *Detected access transmission system error and loss of receive signal*

The S-channel may be used to indicate that the NT1 cannot properly identify the signal received from the network. It may also be used to indicate that the NT1 has received an indication of a transmission abnormality from the network.

5 **Test call from the MSP**

Under study.

6 Call to a test responder from the subscriber installation

The MSP may provide test responders that are accessed via normal call procedures. There may be test responders for various teleservices and bearer services.

The selection of the service involved with the test call is made using the lower-layer and higher-layer compatibility information elements as defined for the normal call control procedures.

7 Loopbacks

7.1 Locations of loopbacks associated with the subscriber installation

Loopback locations for fault localization and verification are shown in Figure 3/M.3602.

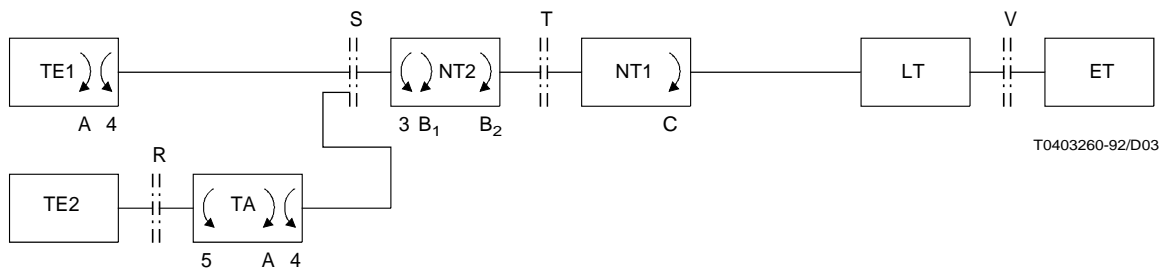

Note – For an explanation of 3, 4, 5, A, B₁, B₂ and C, see Tables 1/M.3602 and 2/M.3602.

FIGURE 3/M.3602

Loopback locations associated with the subscriber installation

7.2 *Loopback characteristics for basic rate subscriber installations*

Characteristics of loopbacks are given in Table 1/M.3602.

TABLE 1/M.3602

Characteristics of loopback mechanisms for basic rate subscriber installations

Loopback	Location	Channel(s) looped back	Loopback type	Control point	Control mechanism	Implementation
3	In NT2, as near as possible to S reference point, towards T (Note 7)	2B + D	Complete, transparent or non-transparent	NT2	Local maintenance (Note 2)	Optional
4	In TA or TE towards S	B ₁ , B ₂ (Note 3)	Partial, transparent or non-transparent	NT2	Layer 3	Optional
5	In TA, as near as possible to R reference point towards S	B ₁ , B ₂	Partial, transparent or non-transparent	NT2	Local maintenance (Note 1)	Optional
C	In NT1, toward the T reference point	B ₁ , B ₂ (Note 3)	Partial, transparent or non-transparent	TE, NT2	Layer 1 (Note 4)	Optional
				Local exchange	Layer 1 (Note 5)	
B ₁	In NT2, as near as possible to S reference point (Note 6)	B ₁ , B ₂ (Note 3)	Partial, transparent or non-transparent	TE, NT2	Layer 1 or Layer 3	Optional
B ₂	In NT2, as near as possible to T reference point	These loopbacks are used as part of an optional internal test. When used, no information should be sent toward the network interface (i.e. INFO 0 is transmitted to the interface).				Optional
A	In the TE towards user					Optional

Note 1 – This loop might also be controlled by signalling in the B-channel as specified in the X- and V-Series Recommendations.

Note 2 – Loopback 3 may be used as part of an NT2 self-test. The self-test may be remotely requested by an MSP.

Note 3 – The B₁ and B₂ channel loopbacks are controlled by separate control signals. However, both loopbacks may be applied at the same time.

Note 4 – An exchange of layer 3 service messages may take place between TE (or NT2) and the exchange prior to the use of the layer 1 control mechanism. However, there are situations where the TE (or NT2) may not receive a reply:

- a) the message may not be transmitted when the interface is in a fault situation;
- b) a network that does not support the layer 3 signalling option, need not respond.

The definition of layer 1 control signal from TE (or NT2) towards NT1 (based on the use of the optional multi-frame) is for further study.

Note 5 – The network controls the loopback by overhead in the transmission system.

Note 6 – Loopback B₁ is applied at each individual interface at reference point S.

Note 7 – Also see Table 1/M.3603 [5] for other loopbacks in the NT2.

7.3 Loopback characteristics for primary rate subscriber installations

Characteristics of loopbacks are given in Table 2/M.3602.

TABLE 2/M.3602

Characteristics of optional loopbacks for primary rate access

Loopback	Location	Channel(s) looped back	Loopback type	Control point	Control mechanism	Implementation
3	In NT2, as near as possible to S reference point, towards T (Note 8)	23 B + D or 24 B channels (Note 4) 30 B + D or 31 B channels (Note 5)	Complete, non-transparent (Note 7)	NT2	Local maintenance (Note 6)	Optional
4	In TA or TE towards S	B, H ₀ , H ₁ (Note 3)	Partial, transparent or non-transparent	NT2	Layer 3	Optional
C	In NT1, towards the T reference point	23 B + D or 24 B channels (Note 4) 30 B + D or 31 B channels (Note 5)	Complete, non-transparent (Note 7)	TE, NT2	Layer 1 (Note 1)	Optional
B ₁	In NT2, as near as possible to S reference point (Notes 2 and 8)	B, H ₀ , H ₁ (Note 3)	Partial, transparent or non-transparent	TE, NT2	Layer 1 or Layer 3	Optional
B ₂	In NT2, as near as possible to T reference point	These loopbacks are used as part of an optional internal test. When used, normal signal should be sent toward the network interface.				Optional
A	In the TE towards user					Optional

Note 1 – Transfer of layer 3 service messages may take place between TE (or NT2) and the exchange prior to the use of the layer 1 control mechanism. However, there are situations where the TE (or NT2) may not receive a reply:

- a) the message may not be transmitted when the interface is in a fault situation;
- b) a network that does not support layer 3 signalling option need not respond.

Definition of layer 1 control signals from TE (or NT2) towards NT1 remains for further study.

Note 2 – Loopback B₁ is applicable to each individual interface as reference point S.

Note 3 – The different B, H₀ and H₁ channel loopbacks are controlled by separate control signals. However, several per channel loopbacks may be applied at the same time.

Note 4 – For 1544 kbit/s interface.

Note 5 – For 2048 kbit/s interface.

Note 6 – Loopback 3 may be used as part of an NT2 self-test. The self-test may be remotely requested by an MSP.

Note 7 – These loopbacks are normally non-transparent and send AIS in the forward direction. However, these loopbacks may be transparent. When transparent loopbacks are used, the device at the loopback point must ensure that the forward signal meets any line code requirements. The test signal used with transparent loopbacks must include RAI and should, if possible, indicate a fault upstream from the loopback location (frames are without continuous error reports).

Note 8 – Also see Table 1/M.3604 [6] for other loopbacks in the NT2.

8 Status request

A piece of equipment, e.g. NT2, TE, TA, may have different states regarding its operation and/or maintenance conditions, e.g. in service, out of service, under test, etc. Definitions of these status are for further study.

An MSP may request an SIMF in the subscriber installation to indicate the current status of a particular terminal and/or of the connected terminal equipment.

9 Fault report to MSP

A subscriber installation which has detected that a TE is in a fault condition (e.g. when it is detected that a threshold has been exceeded) may have the ability to inform immediately (via the ISDN), the MSP responsible for the faulty TE.

After reception of such an information, the MSP may initiate a more precise fault localization.

10 Interrogation of parameter values and counters

An MSP may have the ability to access basic information, such as the instantaneous value of a parameter or counter.

References

- [1] CCITT Recommendation M.3600 *Principles for the maintenance of ISDNs.*
- [2] CCITT Recommendation M.3640 *Management of the D-channel – Data link and network layer.*
- [3] CCITT Recommendation I.430 *Basic user-network interface – Layer 1 specification.*
- [4] CCITT Recommendation I.431 *Primary rate user-network interface – Layer 1 specification.*
- [5] CCITT Recommendation M.3603 *Application of maintenance principles to ISDN basic rate access.*
- [6] CCITT Recommendation M.3604 *Application of maintenance principles to ISDN primary rate access.*