



INTERNATIONAL TELECOMMUNICATION UNION

ITU-T

TELECOMMUNICATION
STANDARDIZATION SECTOR
OF ITU

X.77

(08/97)

SERIES X: DATA NETWORKS AND OPEN SYSTEM
COMMUNICATION

Public data networks – Transmission, signalling and
switching

Interworking between PSPDNs via B-ISDN

ITU-T Recommendation X.77

(Previously CCITT Recommendation)

ITU-T X-SERIES RECOMMENDATIONS
DATA NETWORKS AND OPEN SYSTEM COMMUNICATION

PUBLIC DATA NETWORKS	X.1–X.199
Services and facilities	X.1–X.19
Interfaces	X.20–X.49
 Transmission, signalling and switching	X.50–X.89
Network aspects	X.90–X.149
Maintenance	X.150–X.179
Administrative arrangements	X.180–X.199
OPEN SYSTEM INTERCONNECTION	X.200–X.299
Model and notation	X.200–X.209
Service definitions	X.210–X.219
Connection-mode protocol specifications	X.220–X.229
Connectionless-mode protocol specifications	X.230–X.239
PICS proformas	X.240–X.259
Protocol Identification	X.260–X.269
Security Protocols	X.270–X.279
Layer Managed Objects	X.280–X.289
Conformance testing	X.290–X.299
INTERWORKING BETWEEN NETWORKS	X.300–X.399
General	X.300–X.349
Satellite data transmission systems	X.350–X.399
MESSAGE HANDLING SYSTEMS	X.400–X.499
DIRECTORY	X.500–X.599
OSI NETWORKING AND SYSTEM ASPECTS	X.600–X.699
Networking	X.600–X.629
Efficiency	X.630–X.649
Naming, Addressing and Registration	X.650–X.679
Abstract Syntax Notation One (ASN.1)	X.680–X.699
OSI MANAGEMENT	X.700–X.799
Systems Management framework and architecture	X.700–X.709
Management Communication Service and Protocol	X.710–X.719
Structure of Management Information	X.720–X.729
Management functions	X.730–X.799
SECURITY	X.800–X.849
OSI APPLICATIONS	X.850–X.899
Commitment, Concurrency and Recovery	X.850–X.859
Transaction processing	X.860–X.879
Remote operations	X.880–X.899
OPEN DISTRIBUTED PROCESSING	X.900–X.999

For further details, please refer to ITU-T List of Recommendations.

ITU-T RECOMMENDATION X.77

INTERWORKING BETWEEN PSPDNs VIA B-ISDN

Summary

This Recommendation defines the procedures for interworking case of concatenation of PSDTSs via B-ISDN. It includes reference configurations, protocol stacks and detailed signalling procedures. The Recommendation may be used in the case where packet-switched links between networks providing PSDTS services are transferred over B-ISDN networks as backbone networks.

Source

ITU-T Recommendation X.77 was prepared by ITU-T Study Group 7 (1997-2000) and was approved under the WTSC Resolution No. 1 procedure on the 9th of August 1997.

FOREWORD

ITU (International Telecommunication Union) is the United Nations Specialized Agency in the field of telecommunications. The ITU Telecommunication Standardization Sector (ITU-T) is a permanent organ of the ITU. The ITU-T is responsible for studying technical, operating and tariff questions and issuing Recommendations on them with a view to standardizing telecommunications on a worldwide basis.

The World Telecommunication Standardization Conference (WTSC), which meets every four years, establishes the topics for study by the ITU-T Study Groups which, in their turn, produce Recommendations on these topics.

The approval of Recommendations by the Members of the ITU-T is covered by the procedure laid down in WTSC Resolution No. 1.

In some areas of information technology which fall within ITU-T's purview, the necessary standards are prepared on a collaborative basis with ISO and IEC.

NOTE

In this Recommendation, the expression "Administration" is used for conciseness to indicate both a telecommunication administration and a recognized operating agency.

INTELLECTUAL PROPERTY RIGHTS

The ITU draws attention to the possibility that the practice or implementation of this Recommendation may involve the use of a claimed Intellectual Property Right. The ITU takes no position concerning the evidence, validity or applicability of claimed Intellectual Property Rights, whether asserted by ITU members or others outside of the Recommendation development process.

As of the date of approval of this Recommendation, the ITU had not received notice of intellectual property, protected by patents, which may be required to implement this Recommendation. However, implementors are cautioned that this may not represent the latest information and are therefore strongly urged to consult the TSB patent database.

© ITU 1998

All rights reserved. No part of this publication may be reproduced or utilized in any form or by any means, electronic or mechanical, including photocopying and microfilm, without permission in writing from the ITU.

CONTENTS

		<i>Page</i>
1	Scope of the Recommendation.....	1
2	References.....	1
3	Terms and definitions.....	2
4	Abbreviations.....	2
5	Conventions.....	3
6	Reference configurations.....	3
	6.1 Case where B-ISDN provides PVC.....	3
	6.2 Case where B-ISDN provides SVC.....	4
7	Service parameters and service quality.....	4
	7.1 Peak cell rate.....	4
	7.2 Service quality.....	4
8	Addressing and routing aspects.....	5
9	Physical layer.....	5
10	ATM layer.....	6
11	ATM adaptation layer.....	6
	11.1 U-plane.....	6
	11.2 C-plane.....	8
12	LAPB control layer.....	8
13	Signalling procedures.....	9
	13.1 General.....	9
	13.2 Outgoing X.75 call.....	9
	13.3 Incoming X.75 call.....	10
	13.4 ATM switched virtual channel connection clearing.....	10
	13.5 Restart procedures.....	11
	13.6 Handling of Error condition.....	11
14	ATM-Adaptor functionalities.....	11
	14.1 General.....	11
	14.2 Physical interface.....	13
	14.3 Mapping of signalling information and procedures between the X.75 interface and the S _B /T _B reference point.....	13
	14.4 Synchronization.....	13
	14.5 Maintenance.....	13
Annex A – X.77 example message flow diagrams.....		13
	A.1 X.77 call set-up message flow sequences.....	13
	A.2 X.77 call clearing message flow sequences.....	14
	A.3 X.77 restart message flow sequences.....	15
Annex B – The mapping Q.2931 cause information element identifier field to X.75 cause.....		20

INTERWORKING BETWEEN PSPDNs VIA B-ISDN

(Geneva, 1997)

1 Scope of the Recommendation

This Recommendation defines the procedures for interworking case of concatenation of PSDTSs via B-ISDN. It includes reference configurations, protocol stacks and detailed signalling procedures.

2 References

The following ITU-T Recommendations and other references contain provisions which, through reference in this text, constitute provisions of this Recommendation. At the time of publication, the editions indicated were valid. All Recommendations and other references are subject to revision; all users of this Recommendation are therefore encouraged to investigate the possibility of applying the most recent edition of the Recommendations and other references listed below. A list of the currently valid ITU-T Recommendations is regularly published.

- ITU-T Recommendation E.164 (1997), *The international public telecommunication numbering plan.*
- ITU-T Recommendation E.166 (1996), *Numbering plan interworking for the E.164 and X.121 numbering plans.*
- ITU-T Recommendation I.150 (1995), *B-ISDN asynchronous transfer mode functional characteristics.*
- ITU-T Recommendation I.211 (1993), *B-ISDN service aspects.*
- ITU-T Recommendation I.361 (1995), *B-ISDN ATM layer specification.*
- ITU-T Recommendation I.363 (1993), *B-ISDN ATM Adaptation Layer (AAL) specification.*
- ITU-T Recommendation I.365.1 (1993), *B-ISDN ATM adaptation layer sublayers: Frame relaying service specific convergence sublayer (FR-SSCS).*
- ITU-T Recommendation I.371 (1996), *Traffic control and congestion control in B-ISDN.*
- ITU-T Recommendation I.413 (1993), *B-ISDN user-network interface.*
- ITU-T Recommendation I.430 (1995), *Basic user-network interface – Layer 1 specification.*
- ITU-T Recommendation I.431 (1993), *Primary rate user-network interface – Layer 1 specification.*
- ITU-T Recommendation I.432 (1993), *B-ISDN user-network interface – Physical layer specification.*
- ITU-T draft Recommendation I.505, *Identification and selection of interworking function.*
- ITU-T Recommendation I.580 (1995), *General arrangements for interworking between B-ISDN and 64 kbit/s based ISDN.*
- ITU-T Recommendation Q.2110 (1994), *B-ISDN ATM adaptation layer – Service Specific Connection Oriented Protocol (SSCOP).*
- ITU-T Recommendation Q.2130 (1994), *B-ISDN signalling ATM adaptation layer – Service Specific Coordination Function for support of signalling at the User-Network Interface (SSCF at UNI).*
- ITU-T Recommendation Q.2931 (1995), *Digital Subscriber Signalling System No. 2 (DSS 2) – User-Network Interface (UNI) layer 3 specification for basic call/connection control.*
- ITU-T Recommendation X.1 (1996), *International user classes of service in, and categories of access to, public data networks and Integrated Services Digital Networks (ISDNs).*

- ITU-T Recommendation X.25 (1996), *Interface between Data Terminal Equipment (DTE) and Data Circuit-terminating Equipment (DCE) for terminals operating in the packet mode and connected to public data networks by dedicated circuit.*
- ITU-T Recommendation X.31 (1995), *Support of packet mode terminal equipment by an ISDN.*
- ITU-T Recommendation X.32 (1996), *Interface between Data Terminal Equipment (DTE) and Data Circuit-terminating Equipment (DCE) for terminals operating in the packet mode and accessing a packet-switched public data network through a public switched telephone network or an integrated services digital network or a circuit-switched public data network.*
- ITU-T Recommendation X.75 (1996), *Packet-switched signalling system between public networks providing data transmission services.*
- ITU-T Recommendation X.121 (1996), *International numbering plan for public data networks.*
- ITU-T Recommendation X.122 (1996), *Numbering plan interworking for E.164 and X.121 numbering plans.*
- ITU-T Recommendation X.213 (1995) | ISO/IEC 8348:1996, *Information technology – Open Systems Interconnection – Network service definition.*
- ITU-T Recommendation I.365.4 (1996), *B-ISDN ATM adaptation layer sublayers: Service specific convergence sublayer for HDLC applications.*

3 Terms and definitions

This Recommendation defines the following terms.

3.1 DL-FRAME SSCF: The Service Specific Convergence Function for HDLC Applications. Detailed description for DL-FRAME SSCF is shown in Recommendation I.365.4.

4 Abbreviations

This Recommendation uses the following abbreviations:

AAL	ATM Adaptation Layer
ATM	Asynchronous Transfer Mode
AU	Access Unit
B-ET	Exchange Terminal for Broadband ISDN
B-ISDN	Broadband ISDN
B-NT	Network Termination for Broadband ISDN
B-TA	Terminal Adaptor for Broadband ISDN
BCOB	Broadband Connection Oriented Bearer class
CH	Cell Handler
CPCS	Common Part Convergence Sublayer
CPCS-CI	CPCS-Congestion Indication
CPCS-LP	CPCS-Loss Priority
CPCS-UU	CPCS-User-to-User indication
DNIC	Data Network Identification Code
DTE	Data Terminal Equipment
ISDN	Integrated Services Digital Network
IWF	InterWorking Function
NT	Network Termination

PH	Packet Handler
PMBS	Packet Mode Bearer Service
PSDTS	Packet-Switched Data Transmission Services
PSPDN	Packet-Switched Public Data Network
PVC	Permanent Virtual Circuit
QOS	Quality of Service
SSCF	Service Specific Convergence Function
STE	Signalling Terminal
SVC	Switched Virtual Call
TA	Terminal Adaptor
TE	Terminal Equipment
VCI	Virtual Channel Identifier
VPCI	Virtual Path Connection Identifier

5 Conventions

No particular conventions are included.

6 Reference configurations

There are two cases in terms of the connection establishment method through the B-ISDN network (see Figure 6.1):

- the case where B-ISDN connections are Permanent virtual channel (PVC);
- the case where B-ISDN connections are Switched virtual channel (SVC).

In this configuration, an X.77 signalling terminal (X.77-STE) with X.75 and ATM capabilities is equivalent to a combination consisting of an X.75 Signalling Terminal (STE) and an ATM-Adaptor with ATM capabilities (for ATM capabilities; see clause 14).

Interfaces between X.77-STE/ATM-Adaptor and the B-ISDN are UNI of the B-ISDN. An X.75 datalink connection shall be associated with one ATM virtual channel.

6.1 Case where B-ISDN provides PVC

In the case where ATM connection is PVC, the protocol stack is shown in Figure 6-2.

Either ATM-Adaptor or X.77-STE should support AAL type 5 Common part function and DL-FRAME SSCF (see 11.1.1) to convey X.75 frames.

NOTE – Use of AAL type 1 instead of AAL type 5 should not be precluded.

In the case where AAL type 5 is used, AAL type 5 message mode service will be available. The functionality of the DL-FRAME SSCF only provides for the mapping of the equivalent primitives of AAL to CPCS and vice versa.

In this case, the ATM connection shall be established by procedures beyond the scope of this Recommendation.

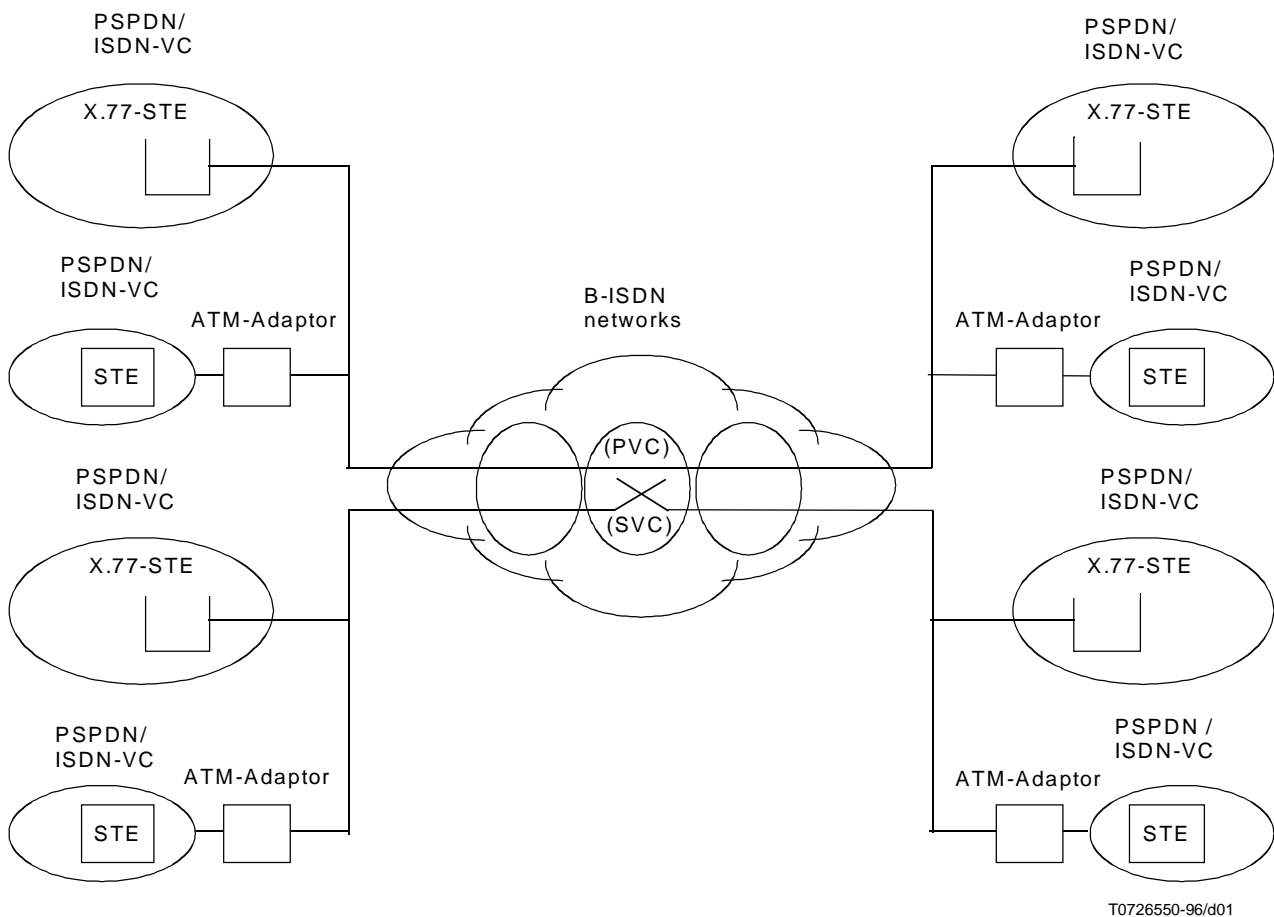

NOTE – SVC case of using ATM-Adaptor is for further study

Figure 6-1/X.77 – Reference configuration of interworking between networks providing PSDTs via B-ISDNs

6.2 Case where B-ISDN provides SVC

6.2.1 U-plane

See 6.1.

6.2.2 C-plane

C-plane protocol stack is shown in Figure 6-3.

ATM connection shall be established by the procedures specified in clause 13.

7 Service parameters and service quality

7.1 Peak cell rate

The Peak Cell Rate in the Source Traffic Descriptor specifies an upper bound on the traffic that can be applied on an ATM connection. Enforcement of this bound by the UPC/NPC allows the network operator to allocate sufficient resources to ensure that the performance objectives (e.g. for Cell Loss Ratio) can be achieved (see 2.4.1/I.371).

7.2 Service quality

The QOS level for Peak Cell Rate may be delivered within a certain probability.

NOTE – Other parameters are for further study.

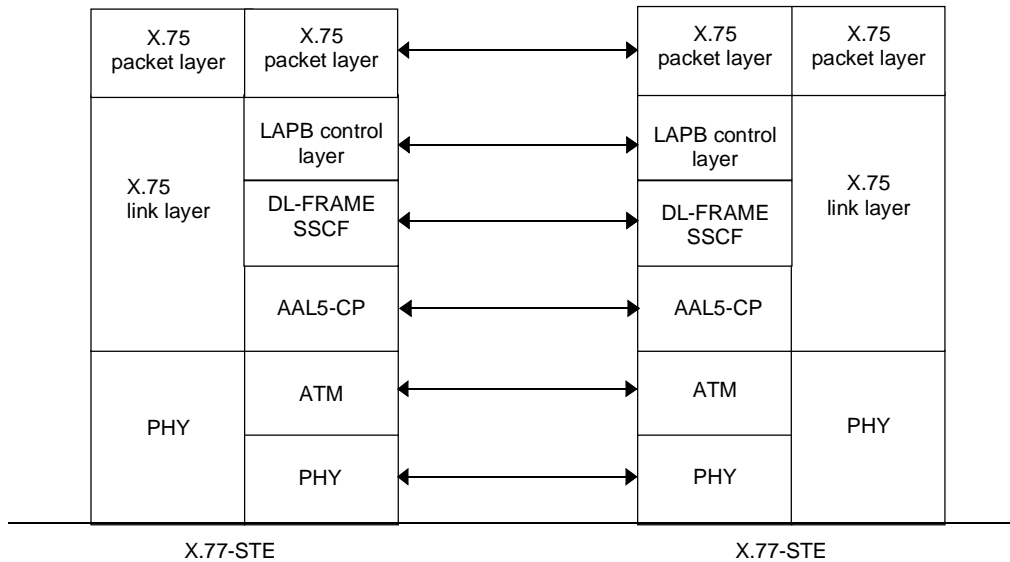
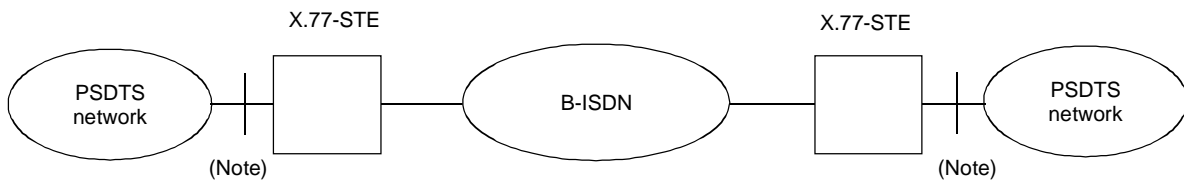

T0726560-96/d02

NOTE – X.75 or some equivalent internal network protocols. This figure shows the protocol stack where X.75 is used here.

Figure 6-2/X.77 – Packet mode interworking based on reference configuration of concatenation of 64 kbit/s based ISDNs via B-ISDN (U-plane)

8 Addressing and routing aspects

One E.164 number of the B-ISDN is associated with one X.77-STE/X.75-STE + ATM-Adaptor.

The Q.2931 SETUP message, when used, contains the request for class C bearer service. The SETUP message also contains the B-ISDN address of the X.77-STE/ATM-Adaptor of the remote PSDTS network.

NOTE – Request of class A bearer service in the SETUP message should not be precluded.

X.75 call request packet contains the X.121 or E.164 address of the called DTE associated with the destination network.

X.75 multilink case is not included in this Recommendation. However, X.77-STE/ATM-Adaptor can establish multiple ATM connection to same destination X.77-STE/ATM-Adaptor using multiple ATM virtual path and virtual channel.

9 Physical layer

Physical medium characteristics of UNI defined in Recommendation I.432 apply.

ATM cell mapping into Plesiochronous Digital Hierarchy (PDH) defined in Recommendation G.702 is also possible. See Recommendation G.804.

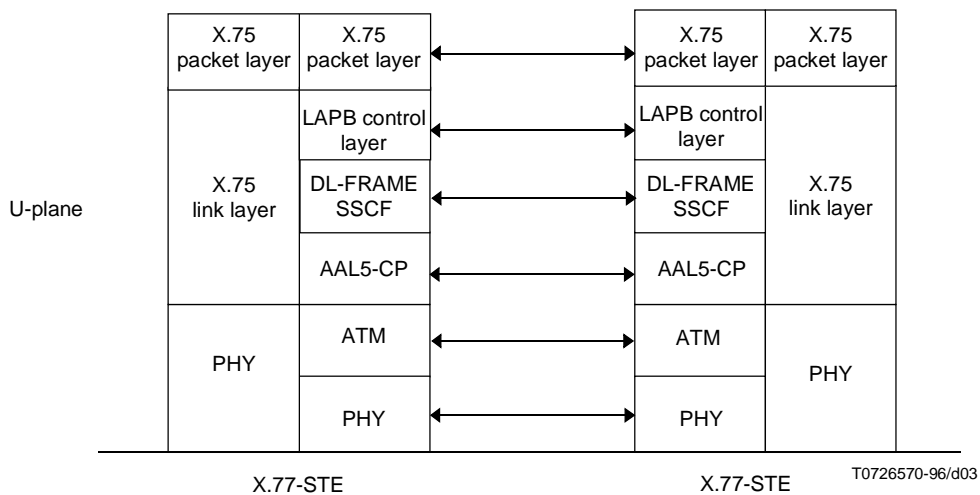
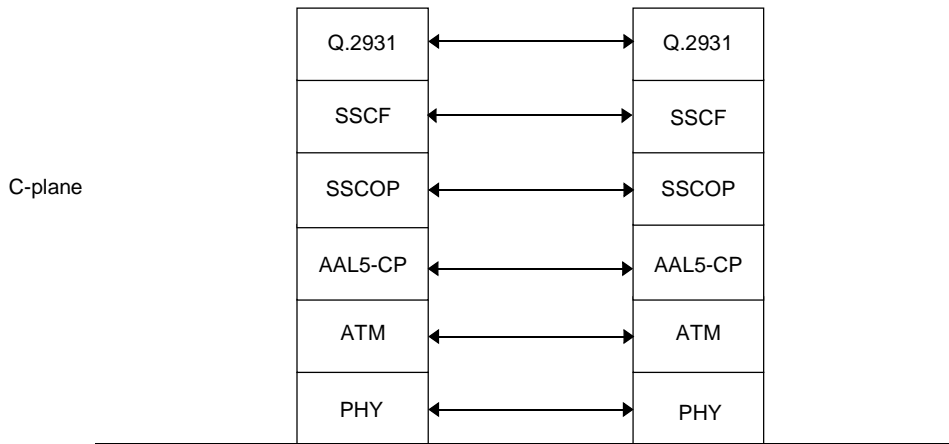
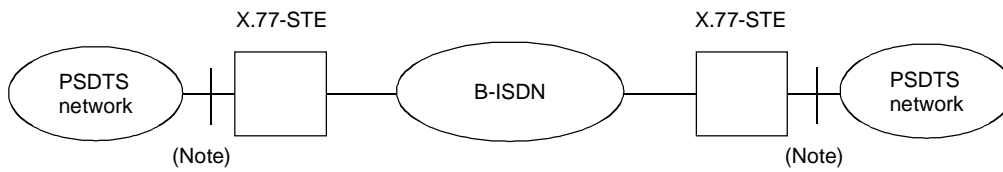

NOTE – X.75 or some equivalent internal network protocols. This figure shows the protocol stack where X.75 is used here.

Figure 6-3/X.77 – Packet mode interworking based on reference configuration of concatenation of 64 kbit/s-based ISDNs via B-ISDN (C-plane)

10 ATM layer

See Recommendation I.361 for ATM layer specification.

11 ATM adaptation layer

11.1 U-plane

Type 5 of the AAL functions applies (see Recommendations I.362 and I.363).

11.1.1 DL-FRAME SSCF formats

The Service Specific Convergence Function for HDLC Applications (DL-FRAME SSCF) provides the service to map DL-FRAME primitives to AAL type 5 primitives and HDLC framing and bit error detection service (see Recommendation I.365.4).

11.1.2 AAL5-CP PDU formats

The Segmentation and Reassembly (SAR) and Common Part Convergence Sublayer (CPCS) of ATM Adaptation Layer 5 in conjunction with the ATM-Layer ATM-user-to-user indication (end of PDU) provides segmentation and reassembly for DL-FRAME SSCF PDUs. The Common part AAL5 PDU formats are shown in Figure 11.1. In this figure, the AAL5-CPCS CRC provides error detection over the DL-FRAME SSCF PDU.

NOTE – Notification of congestion indication at ATM layer to LAPB control layer may be achieved by layer management methods.

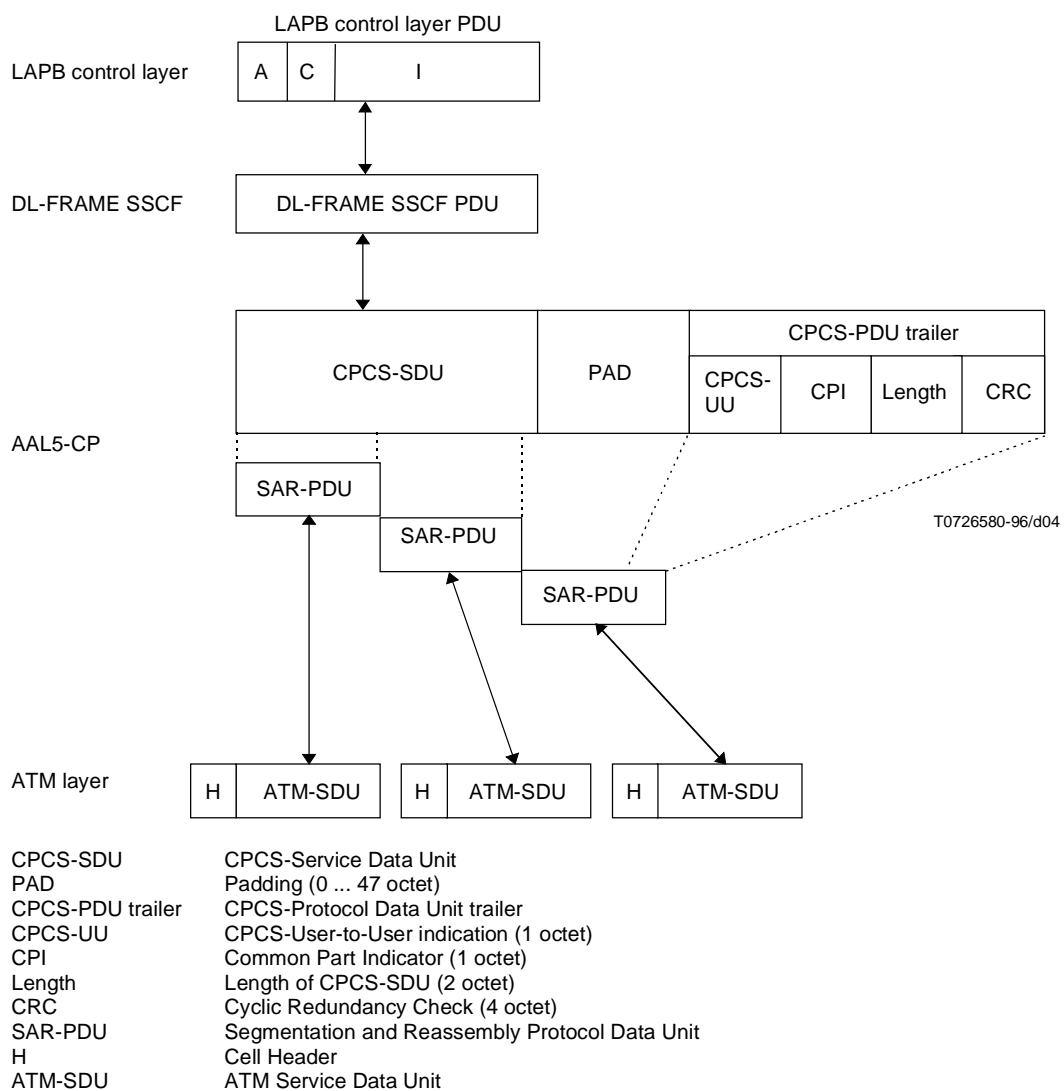

NOTE – See Recommendation I.363.

Figure 11-1/X.77 – The common part AAL5 PDU formats

11.2 C-plane

Service class C and Type 5 of the AAL functions applies (see Recommendations I.362 and I.363). Over the AAL-Type 5, Service Specific Connection Oriented Protocol (SSCOP) (see Recommendation Q.2110) is used to transfer datalink frames which convey Signalling messages (see clause 13). In addition, SSCF-UNI (see Recommendation Q.2130) is used to coordinate between SSCOP and Q.2931.

12 LAPB control layer

LAPB control layer provides the data link procedures defined in Recommendation X.75, except the HDLC framing procedures. In this Recommendation, HDLC framing means flag, abort sequences, zero-bit insertions and Frame Check Sequences (FCS) defined in Recommendation X.75.

LAPB control layer uses a PDU format identical to X.75 Link layer format minus the FCS, FLAGS, and zero insertion. A PDU format structured is shown in Tables 12-1 and 12-2.

Table 12-1/X.77 – PDU formats for LAPB control layer (modulo 8)

Bit order of transmission	12345678	1 to 8	
	Address	Control	
	A 8 bits	C 8 bits	
Bit order of transmission	12345678	1 to 8	
	Address	Control	Information
	A 8 bits	C 8 bits	I N bits
NOTE – LAPB Address field coding is decided according to the procedures described in 2.4.2/X.75.			

Table 12-2/X.77 – PDU formats for LAPB control layer (modulo 128)

Bit order of transmission	12345678	1 to ^{a)}	
	Address	Control	
	A 8 bits	C bits ^{a)}	
Bit order of transmission	12345678	1 to ^{a)}	
	Address	Control	Information
	A 8 bits	C bits ^{a)}	I N bits
$0 \leq N \leq N1-40$ ^{a)} 16 bits for frame formats that contain sequence numbers; 8 bits for frame formats that do not contain sequence numbers. NOTE – LAPB Address field coding is decided according to the procedures described in 2.4.2/X.75.			

Table 12-3/X.77 – PDU formats for LAPB control layer (modulo 32768)

Bit order of transmission	12345678	1 to ^{a)}	
	Address	Control	
	A 8 bits	C bits ^{a)}	
Bit order of transmission	12345678	1 to ^{a)}	
	Address	Control	Information
	A 8 bits	C bits ^{a)}	I N bits
$0 \leq N \leq N1-56$ ^{a)} 32 bits for frame formats that contain sequence numbers; 8 bits for frame formats that do not contain sequence numbers. NOTE – LAPB Address field coding is decided according to the procedures described in 2.4.2/X.75.			

13 Signalling procedures

13.1 General

The procedures specified in this Recommendation are based on the port access method of interworking.

An ATM virtual channel connection is established between the X.77-STE. An ATM-SVC is established and released using the procedures specified in this clause. The ATM virtual channel connection may be either a PVC or an SVC. An ATM PVC is established by means which are beyond the scope of this Recommendation.

The physical access connection between an X.77-STE and ATM network must be established by procedures beyond the scope of this Recommendation before the ATM virtual channel connection procedures specified in this Recommendation can be used.

Within the physical access connection, in-channel signalling as specified in Recommendation Q.2931 is used to establish ATM SVCs. In-channel signalling is employed on the virtual channel identified by the Virtual Channel Identifier (VCI) = 5. The ATM Adaptation Layer protocol employed on the VCI=5 channel is Signalling ATM Adaptation Layer (SAAL) protocol which is specified in Recommendations Q.2110 and Q.2130.

Example message sequences are shown in Annex A.

NOTE 1 – VCI value for Q.2931 point-to-multipoint procedure needs to be added once defined in this Recommendation.

NOTE 2 – No X.75 PVCs are allowed over an ATM SVC.

NOTE 3 – If an ATM PVC is established through the B-ISDN, then X.75 PVCs as well as X.75 virtual calls may be established between the calling X.77-STE and remote X.77-STE.

13.2 Outgoing X.75 call

A calling X.77-STE, wishing to set up an X.75 virtual call to a remote X.77-STE, uses an ATM virtual channel connection that is established through the B-ISDN to the X.77-STE. If no ATM virtual channel connection is established through the B-ISDN to the remote X.77-STE, the calling X.77-STE uses the procedures specified in 13.2.1 below before setting up the X.75 virtual call.

13.2.1 Outgoing ATM switched virtual channel connection set-up

The ATM virtual channel connection is established on a virtual channel available for support of user information on the B-ISDN user-network interface as defined in clause 5/Q.2931.

A calling X.77-STE uses the following procedures:

- 1) The procedures specified in 5.1.1/Q.2931 for the ATM connection set-up. In the SETUP message sent by the calling X.77-STE.
 - i) The Called Party Address information element contains the address of the remote X.77-STE.
NOTE – The procedures for overlap sending specified in 6.5.2/Q.2931 do not apply.
 - ii) The Broadband Bearer Capability information element shall be encoded as follows:
 - bearer class set to "BCOB-C";
 - traffic type set to "variable bit rate";
 - timing requirements set to "end-to-end timing not required";
 - susceptibility to clipping set to "not susceptible to clipping";
 - user plane connection configuration set to "point-to-point".NOTE – Selection of Broadband Transfer Capability specified in Recommendation Q.2761.2 is for further study.
 - iii) The Broadband Low Layer Information element is included to pass compatibility information from the calling X.77-STE to the remote X.77-STE. The user information layer 3 protocol (octet 7 of the Broadband Low Layer Information element) is encoded as follows:
 - Recommendation X.75 packet layer.The user information layer 2 protocol (octet 6 of the Broadband Low Layer information element) is encoded as follows:
 - Recommendation X.75. Single Link Procedure (SLP).
- 2) The procedures specified in 5.1.2/Q.2931 for connection identifier (VPCI/VCI) allocation and selection.
- 3) The procedures specified in 5.1.3/Q.2931 to request a certain Quality of Service (QOS).

13.2.2 Outgoing X.75 virtual call set-up and release

The X.75 procedures specified in Recommendation X.75 apply.

NOTE – A logical channel number is unique within a VCI.

13.3 Incoming X.75 call

A called X.77-STE, wished to set up an X.75 virtual call from a remote X.77-STE, uses an ATM virtual channel connection that is established through the B-ISDN from the X.77-STE.

13.3.1 Incoming ATM switched virtual channel connection set-up

When X.77-STE receives a Q.2931 SETUP message, it checks the following conditions in addition to performing the routing functions:

- availability of the X.75 logical channel, either two-way or incoming, on which the *call request* packet is sent.

NOTE – Some other X.77-STE may perform either to decide to offer the call or reject the call.

13.3.2 Incoming X.75 virtual call set-up and release

The X.75 procedures specified in Recommendation X.75 apply.

NOTE – A logical channel number is unique within a VCI.

13.4 ATM switched virtual channel connection clearing

The X.77-STE follows the procedures specified in 5.4.3/Q.2931 to clear an ATM SVC.

ATM PVC cannot be cleared by the X.77-STE using Q.2931 clearing procedures. It is cleared by procedures (e.g. administrative, management procedures) which are beyond the scope of this Recommendation.

The clear collision procedures specified in 5.4.5/Q.2931 apply.

13.5 Restart procedures

The Restart procedures specified in 5.5/Q.2931 apply.

If a Q.2931 RESTART message is received by the X.77-STE during the X.75 data transfer phase, the X.75 virtual calls shall be treated as follows:

- For switched virtual channel connections, an X.75 clear request packet shall be sent with cause #9, "out of order" and diagnostic #0, "no additional information".
- For any X.75 virtual calls which are established on a permanent virtual channel connection to the X.77-STE, no action shall be taken.

13.6 Handling of Error condition

When a B-ISDN access connection failure occurs, the rules of 5.6/Q.2931 shall apply. In addition, the following rules for determining the appropriate cause to be used shall apply in order of priority decreasing:

- 1) If a Q.2931 clearing message is received from the B-ISDN by the X.77-STE to clear ATM switched virtual channel connection while X.75 virtual calls still exist on ATM switched virtual channel connection, the X.77-STE clears the corresponding calls in PSPDN/ISDN-VC with cause #17 "remote procedure error" and diagnostic code #64 "call set-up or call clearing problem".
- 2) If a Q.2931 RESTART message is received by the B-ISDN and an ATM switched virtual channel connection is released as a result while X.75 virtual calls still exist on the ATM switched virtual channel connection, the X.77-STE also clears the corresponding calls in PSPDN/ISDN-VC with cause #9 "out of order" and diagnostic code #0 "no additional information".
- 3) If the establishment of an ATM SVC that is triggered by an incoming X.75 virtual call is rejected by the called X.77-STE using Q.2931 messages on the Virtual Channel Identified by VCI=5, the calling X.77-STE clears the incoming X.75 virtual call using an appropriate cause from Table B.1.
- 4) If a condition exists that prevents a Q.2931 SETUP message, that is triggered by an incoming X.75 virtual call, from being delivered to the called X.77-STE on the Virtual Channel Identified by VCI=5, the calling X.77-STE clears the incoming X.75 virtual call in the PSPDN with a cause that is selected appropriate to the condition from Table B.1.
- 5) If a Q.2931 SETUP message is sent as a result of an incoming X.75 virtual call on a Virtual Channel Identified by VCI=5 to the called X.77-STE and no response is received prior to the second expiry of Timer T303, rule 4) above applies.
- 6) If a Q.2931 SETUP message is sent as a result of an incoming X.75 virtual call on a Virtual Channel Identified by VCI=5 to the called X.77-STE and a response other than a call rejection is received which results in the clearing of the ATM SVC, the calling X.77-STE clears the incoming X.75 call request packet call in using the appropriate cause from Table B.1 relative to the cause sent in the clearing message.
- 7) In case of momentary failure within the B-ISDN network, the X.77-STE will reset the permanent virtual circuit as described in 3.4.2/X.75, with the cause "Network congestion", and then will continue to handle data traffic. If the network has a temporary inability to handle data traffic, the X.77-STE shall reset the permanent virtual circuit with the cause "Network out of order". When the network is again able to handle data traffic, the X.77-STE should reset the permanent virtual circuit with the cause "Network operational".

14 ATM-Adaptor functionalities

14.1 General

ATM-Adaptor functions are needed to use the existing X.75-STE at the S_B/T_B reference point (see Figure 14-1). In this case, the ATM connection shall be PVC.

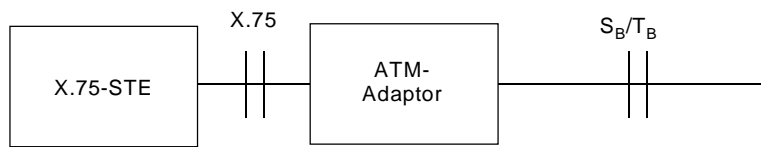

T0726590-96/d05

NOTE 1 – An adaptor function supports only one X.75-STE at the X.75 interface.

NOTE 2 – X.77 functions are equivalent to a combination consisting of an X.75-STE and ATM-Adaptor.

Figure 14-1/X.77 – The reference configuration of ATM- Adaptor

Main functionalities which are provided by the ATM-Adaptor are the following:

- mapping of signalling information and procedures between the X.75 interface and the S_B/T_B reference point;
- synchronization;
- maintenance.

In the following, these main functionalities are described. The procedures at the S_B/T_B reference point are described in clause 13.

The protocol stack is shown in Figure 14-2.

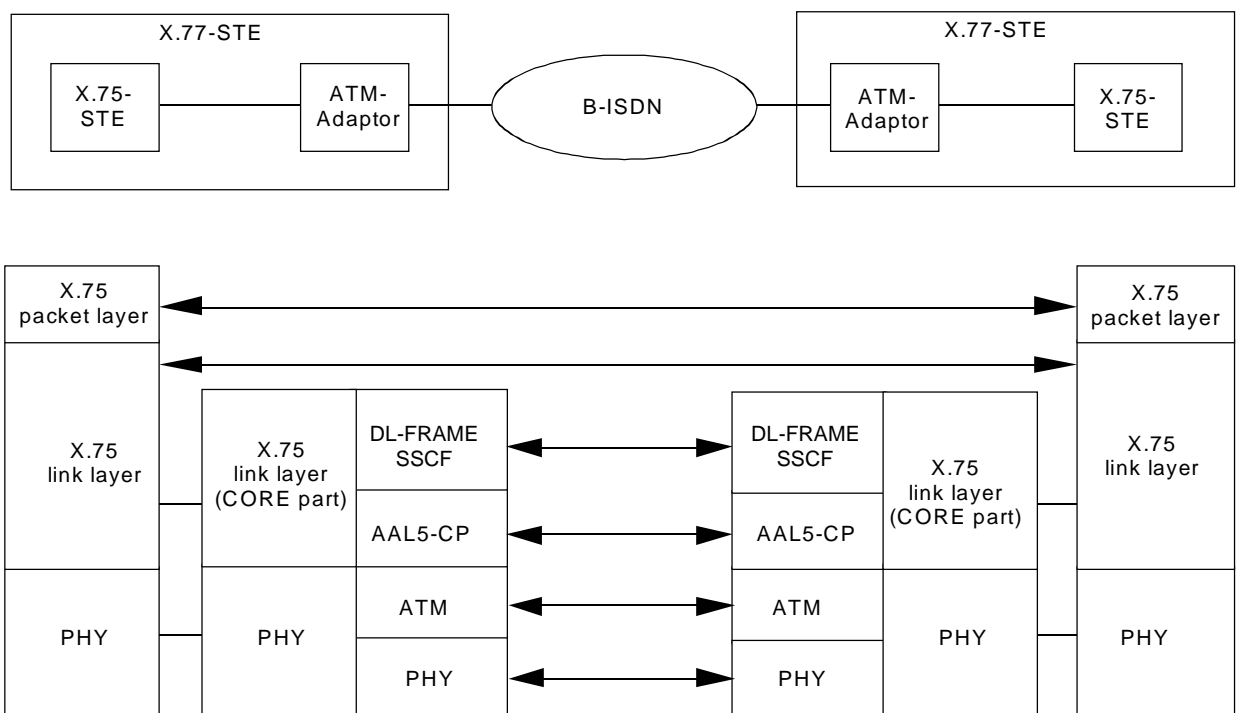

T0726600-96/d06

Figure 14-2/X.77 – Packet mode interworking using ATM-Adaptor

14.2 Physical interface

The physical interfaces supported at the X.75 interface are those defined in clause 1/X.75.

14.3 Mapping of signalling information and procedures between the X.75 interface and the S_B/T_B reference point

14.3.1 Handling of X.75 LAPB frames

The rate adaption is inherent in segmentation of X.75 LAPB frames and cell based ATM transfer on the S_B/T_B reference point. In particular, the contiguous flag transmission perceived at the X.75 interface shall not be repeated at the S_B/T_B reference point.

14.3.2 Signalling

The ATM connection between the ATM-Adaptor and the remote X.77-STE/ATM-Adaptor is always available. No ATM-Adaptor functionalities are required to initiate the establishment of the ATM connection. ATM connection establishment method is beyond the scope of this Recommendation.

As shown in Figures A.1 and A.2, X.75 procedures are performed end-to-end using the ATM connection via the AAL and SSCF functions defined in 11.1.

14.4 Synchronization

Synchronization between the ATM-Adaptor and the remote X.77-STE/ATM-Adaptor is provided by the cell synchronization mechanism specified in Recommendation I.361.

14.5 Maintenance

The functionalities specified in Recommendation I.610 apply.

Annex A

X.77 example message flow diagrams

A.1 X.77 call set-up message flow sequences

Figures A.1 through A.4 present the complete sequences associated with setting up a call across two X.77-STE. Figures A.1 through A.3 present the individual stages or levels for setting up the call:

- To set up a call across two X.77-STE, first see Figure A.1. Figure A.1 presents the Q.2931 procedures for setting up the ATM channel. When the ATM channel is set up, see Figure A.2.
- Figure A.2 presents the procedures for setting up the X.75 data link between the X.77-STE. When the X.75 data link is already set up, see Figure A.3.
- Figure A.3 presents the procedures for passing the X.75 (of equivalent) Call Request across the two X.77-STE and establishing the call.

Figure A.4 presents the combining of these three figures (A.1 through A.3) into a complete sequence for setting up a call across two X.77-STE.

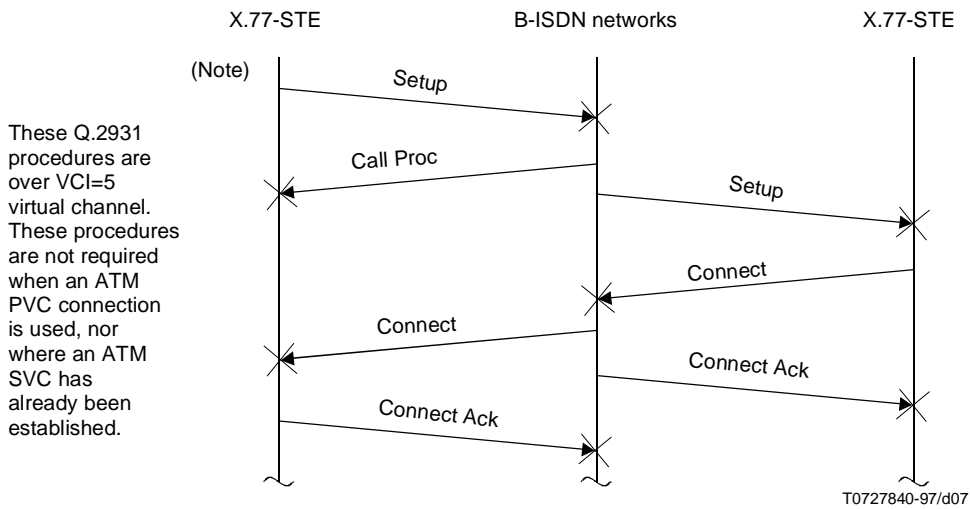

NOTE – The specific event that triggers or starts this X.77 defined sequence is network implementation dependent. Some networks may establish the SVC independent of any other service request; other networks may wait to establish the SVC upon the presentation of an X.75 (or equivalent) Call Request to the first STE. As such, for purposes of this diagram – and all others within this annex – the actual trigger event is not specified.

Figure A.1/X.77

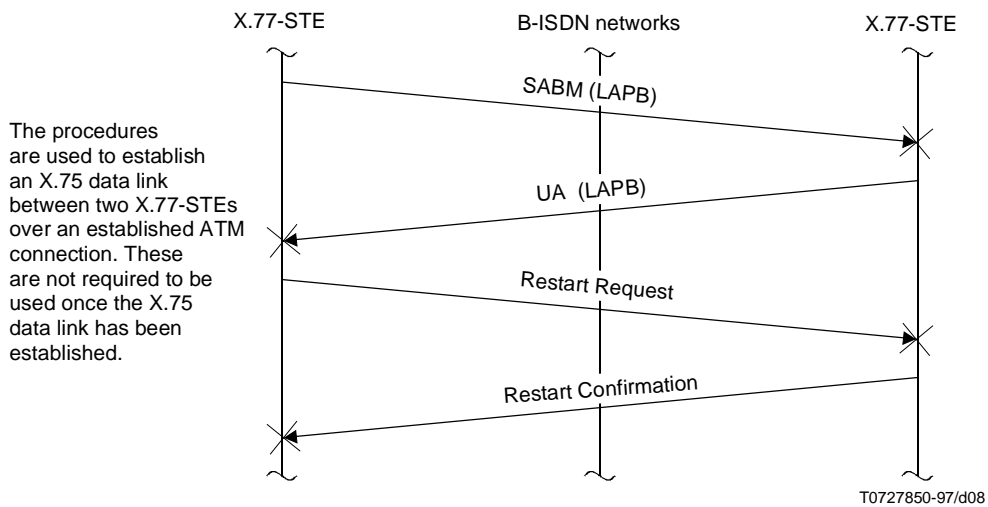

Figure A.2/X.77

A.2 X.77 call clearing message flow sequences

Figures A.5 through A.8 present the complete sequences associated with breaking down a call across two X.77-STEs. Figures A.5 through A.7 present the individual stages or levels for clearing the call:

- To clear down a call all across two X.77-STEs, first see Figure A.5. Figure A.5 presents the procedures for passing the X.75 (or equivalent) Call Request across the two X.77-STEs and clearing down the X.75 call. When the X.75 call is cleared, see Figure A.6.

- Figure A.6 presents the procedures for breaking down the X.75 data link between the X.77-STE. Note that some networks may select to maintain the X.75 data link layer for further use. When the X.75 data link is broken down, see Figure A.7.
- Figure A.7 presents the Q.2931 procedures for breaking down the ATM channel. Note that some networks may select to maintain the ATM channel for further use.

Figure A.8 presents the combining of these three figures (A.5 through A.7) into a complete sequence for clearing a call across two X.77-STE.

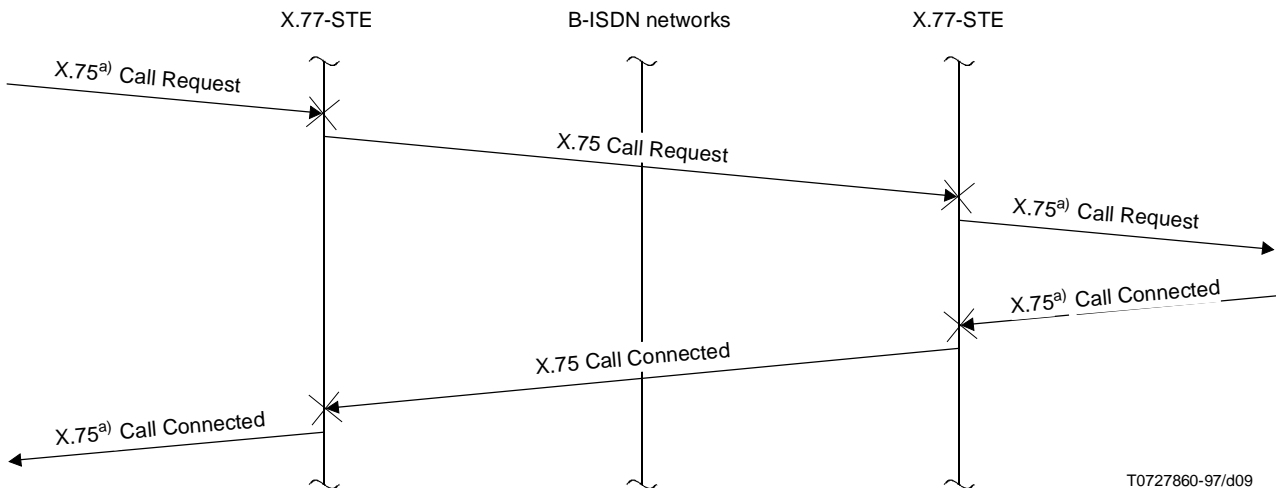

a) X.75 or some equivalent internal network protocol.

Figure A.3/X.77

A.3 X.77 restart message flow sequences

Figures A.9 and A.10 present the sequences associated with restarting the interface across two X.77-STE. Figure A.9 (along with Figures A.6 and A.7) present the individual stages or levels for restarting the interface:

- To restart the interface across two X.77-STE, first see Figure A.9. Figure A.9 presents the procedures for passing an X.75 Restart Request between the two X.77-STE. When the restart is confirmed, see Figure A.6.
- Figure A.6 presents the procedures for breaking down the X.75 data link between the X.77-STE. Note that some networks may select to maintain the X.75 data link layer for further use. When the X.75 data link is broken down, see Figure A.7.
- Figure A.7 presents the Q.2931 procedures for breaking down the ATM channel. Note that some networks may select to maintain the ATM channel for further use.

Figure A.10 presents the combining of these three figures (A.9, A.6 and A.7) into a complete sequence for restarting the interface across two X.77-STE.

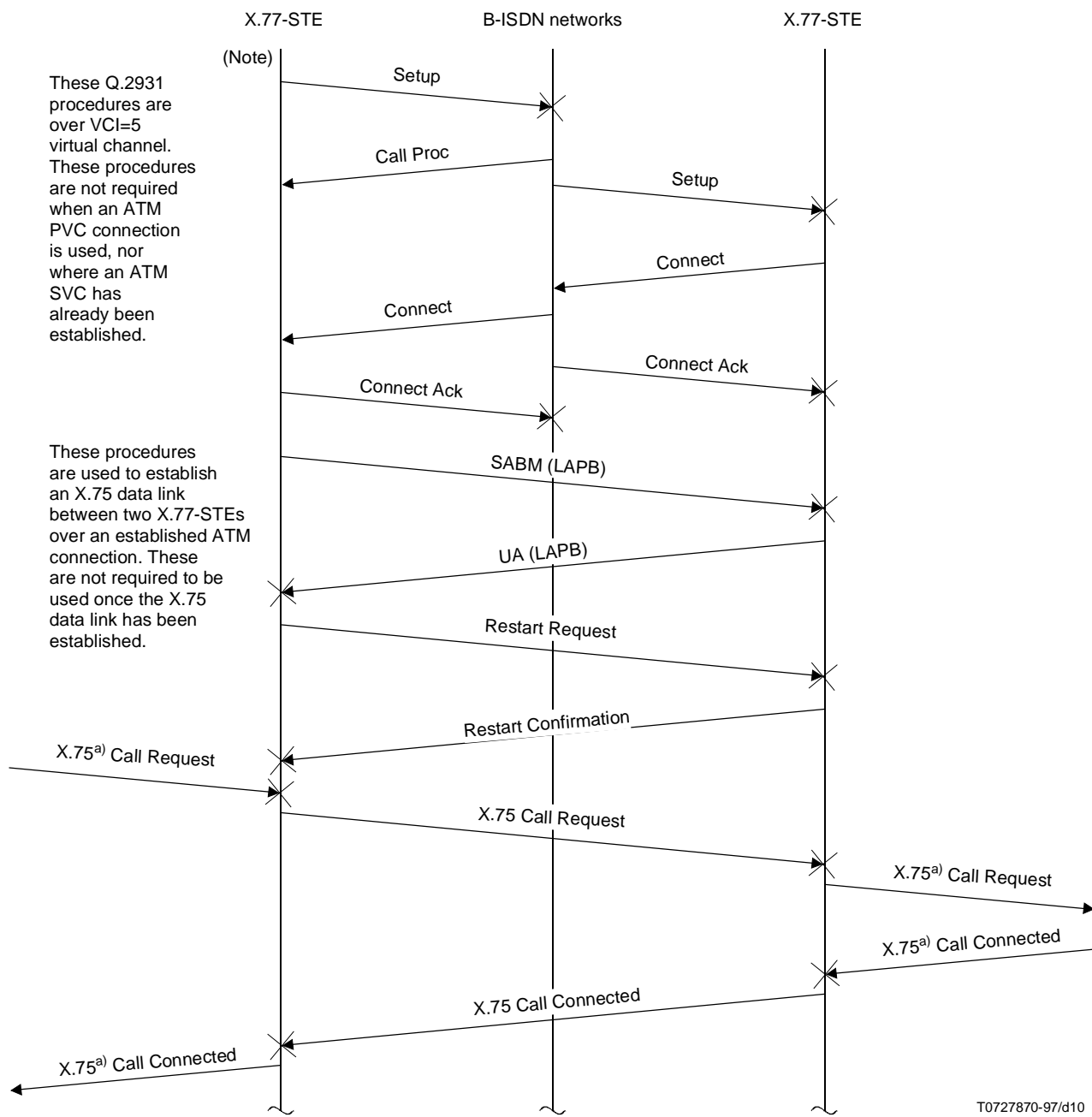

^{a)} X.75 or some equivalent internal network protocol.

NOTE – The specific event that triggers or starts this X.77 defined sequence is network implementation dependent. Some networks may establish the SVC independent of any other service request; other networks may wait to establish the SVC upon the presentation of an X.75 (or equivalent) Call Request to the first STE. As such, for purposes of this diagram – and all others within this annex – the actual trigger event is not specified.

Figure A.4/X.77

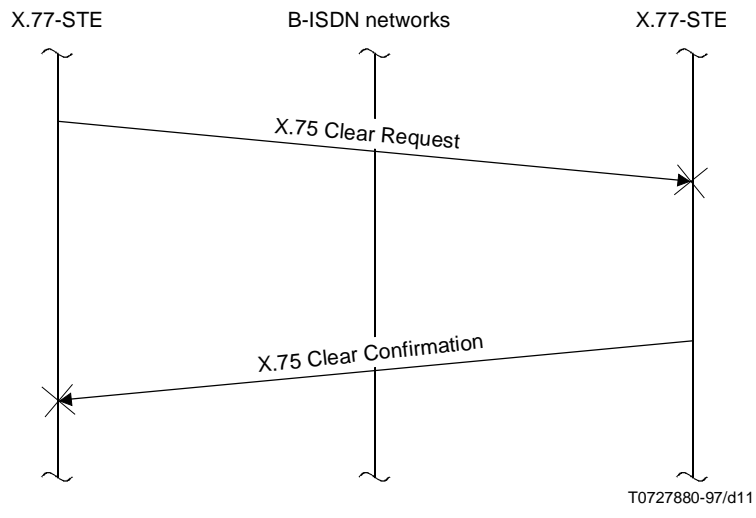

Figure A.5/X.77

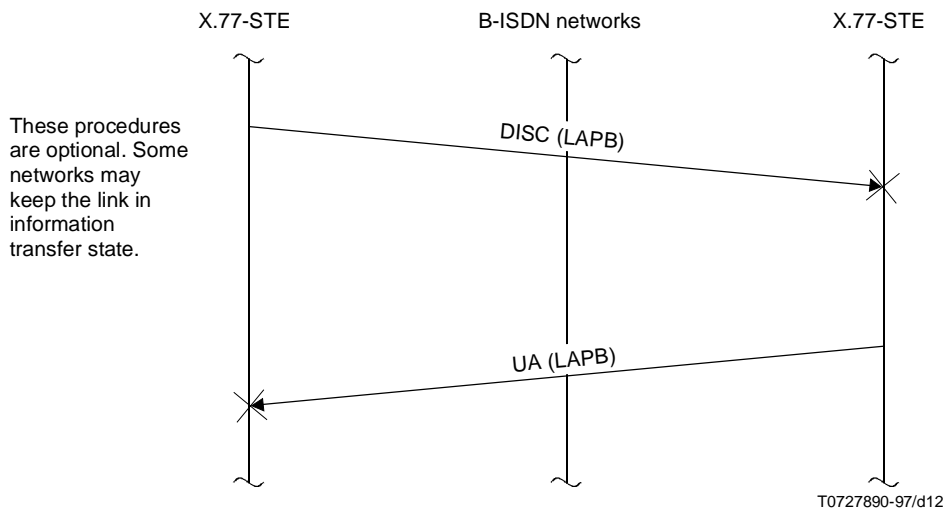
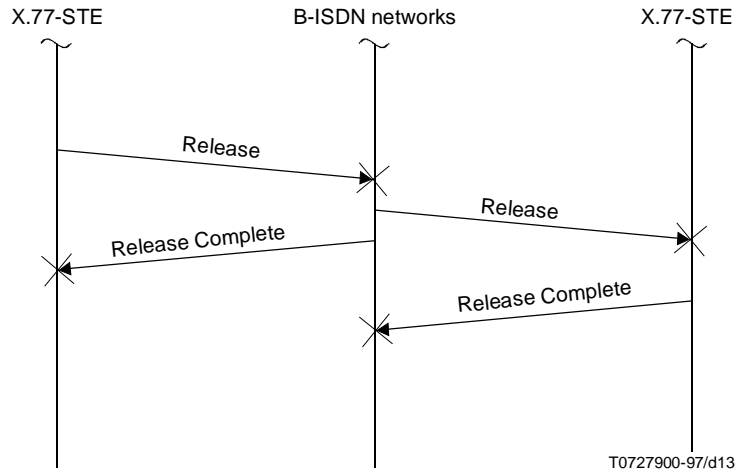

Figure A.6/X.77

These procedures do not apply when an ATM PVC is used. When an ATM SVC is used, these Q.2931 procedures are over VCI=5 virtual channel. However, some networks that provide ATM SVC may choose to keep the SVC established.



T0727900-97/d13

Figure A.7/X.77

These procedures are optional. Some networks may keep the link in information transfer state.

These procedures do not apply when an ATM PVC is used. When an ATM SVC is used, these Q.2931 procedures are over VCI=5 virtual channel. However, some networks that provide ATM SVC may choose to keep the SVC established.

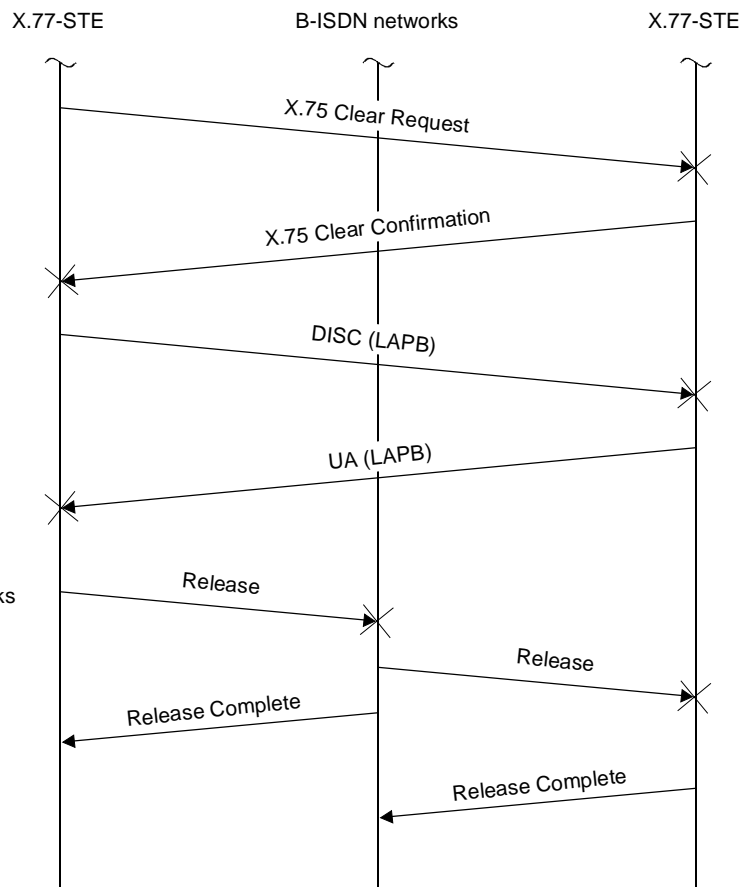

T0727910-97/d14

Figure A.8/X.77

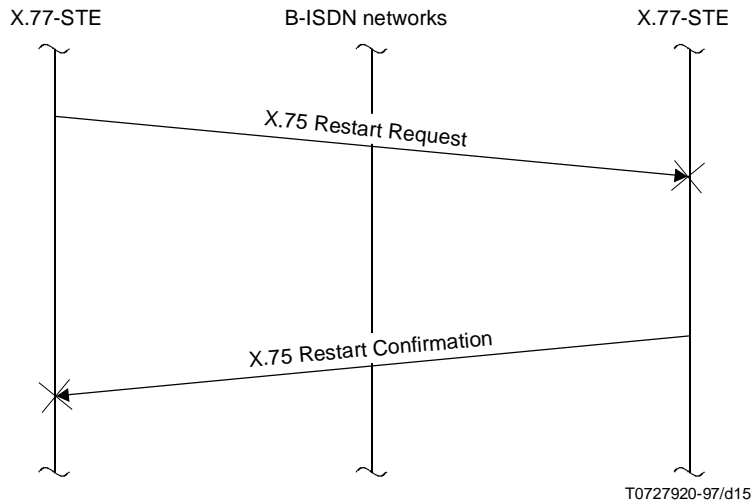

Figure A.9/X.77

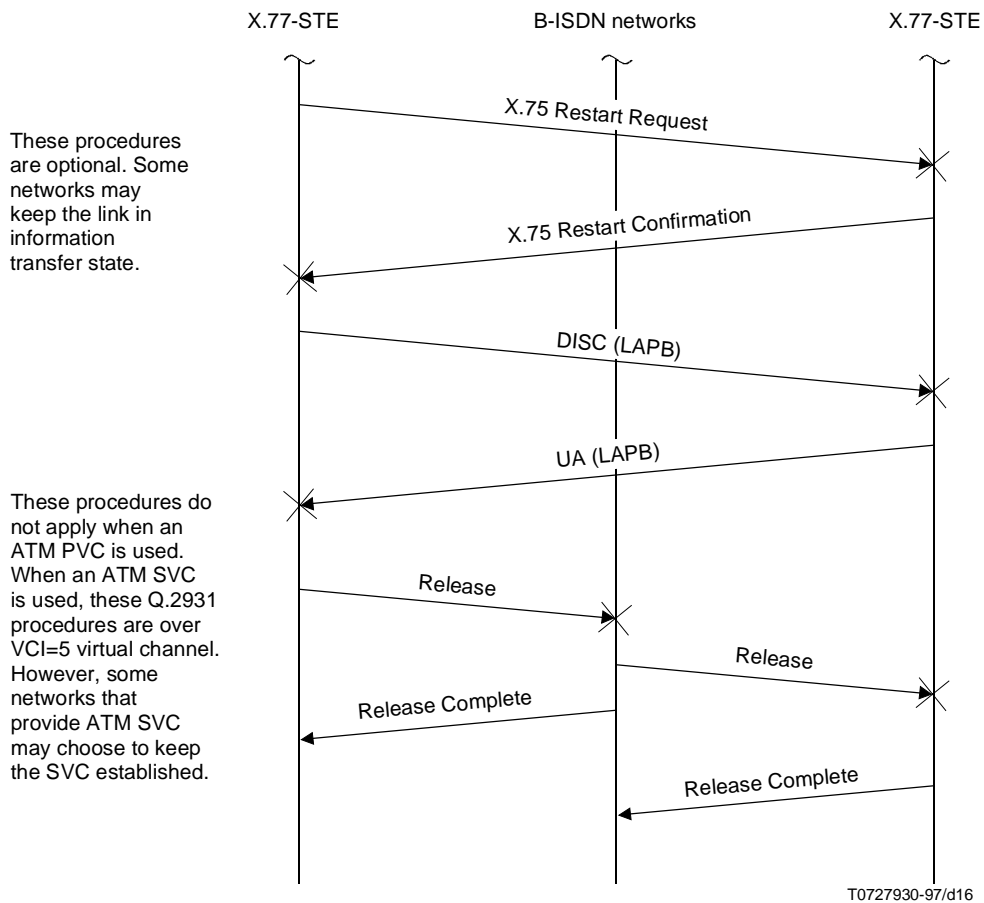

Figure A.10/X.77

Annex B

The mapping Q.2931 cause information element identifier field to X.75 cause

Table B.1/X.77 – Mapping of Q.2931 cause fields to X.75 cause field

Item	Q.2931 cause	Code	Q.2931 Diagnostic	X.75 Cause	Code	X.75 Diagnostic	Code
1	Unassigned or unallocated number	1	Condition: unknown, transient, permanent	Not obtainable	13	Invalid called address	67
2	No route to destination	3	Condition: unknown, transient, permanent	Not obtainable	13	Invalid called address	67
3	Channel unacceptable	6	None	Remote procedure error	17	<i>Call set-up or clearing problem</i>	64
4	Normal clearing	16	Condition: unknown, transient, permanent	DTE originated	0	No additional information	0
5	User busy	17	None	Number busy	1	No logical channel available	71
6	No user responding	18	None	Remote procedure error	17	<i>Call set-up or clearing problem</i>	64
7	User alerting, no answer.	19	None	Remote procedure error	17	<i>Call set-up or clearing problem</i>	64
8	Call rejected	21	Condition: unknown, transient, permanent + user applied diagnostics	DTE originated	0	No additional information	0
9	Number changed	22	New destination address	Not obtainable	13	Invalid called address	67
10	Destination out of service	27	None	Out of order	9	No additional information	0
11	Invalid number format (Incomplete number)	28	None	Not obtainable	13	Invalid called address	67
12	Normal, unspecified.	31	None	DTE originated	0	No additional information	0
13	No circuit/channel available	34	None	Number busy	1	No logical channel available	71
14	Network out of order	38	None	Out of order	9	No additional information	0
15	Temporary failure	41	Network identity	Out of order	9	No additional information	0
16	Switching equipment congestion	42	Network identity	Network congestion	5	No additional information	0

Table B.1/X.77 – Mapping of Q.2931 cause fields to X.75 cause field (continued)

Item	Q.2931 cause	Code	Q.2931 Diagnostic	X.75 Cause	Code	X.75 Diagnostic	Code
17	Requested circuit or channel not available	44	None	Number busy	1	No logical channel available	71
18	Resources unavailable unspecified	47	None	Network congestion	5	No additional information	0
19	Quality of service unavailable	49	Condition: unknown, transient, permanent	Network congestion	5	No additional information	0
20	Bearer capability not authorized	57	Bearer capability information element identifier	Incompatible destination	33	No additional information	0
21	Bearer capability not presently available	58	Bearer capability information element identifier	Remote procedure error	17	Call set-up or clearing problem	64
22	Service or option not available, unspecified.	63	None	Remote procedure error	17	Call set-up or clearing problem	64
23	Bearer service not implemented	65	Attribute numbers	Incompatible destination	33	No additional information	0
24	Channel type not implemented	66	Channel type	Remote procedure error	17	Call set-up or clearing problem	64
25	Service or option not implemented, unspecified.	79	None	Remote procedure error	17	Call set-up or clearing problem	64
26	Invalid call reference value	81	None	Remote procedure error	17	Call set-up or clearing problem	64
27	Identified channel does not exist	82	Channel identity	Remote procedure error	17	Call set-up or clearing problem	64
28	Incompatible destination	88	Incompatible parameter	Incompatible destination	33	No additional information	0
29	Invalid message	95	None	Remote procedure error	17	Call set-up or clearing problem	64
30	Mandatory information element is missing	96	Information element	Remote identifier(s) procedure error	17	Call set-up or clearing problem	64
31	Message type non-existent or not implemented	97	Message type	Remote procedure error	17	Call set-up or clearing problem	64

Table B.1/X.77 – Mapping of Q.2931 cause fields to X.75 cause field (concluded)

Item	Q.2931 cause	Code	Q.2931 Diagnostic	X.75 Cause	Code	X.75 Diagnostic	Code
32	Message not compatible with call state or message type non-existent or not implemented	98	Message type	Remote procedure error	17	Call set-up or clearing problem	64
33	Information element non-existent or not implemented	99	Information element identifier(s)	Remote procedure error	17	Call set-up or clearing problem	64
34	Invalid information element contents	100	Information element identifier(s)	Remote procedure error	17	Call set-up or clearing problem	64
35	Message not compatible with call state	101	Message type	Remote procedure error	17	Call set-up or clearing problem	64
36	Recovery on timer expiry	102	Timer number	Remote procedure error	17	Call set-up or clearing problem	64
37	Protocol error unspecified	111	None	Remote procedure error	17	Call set-up or clearing problem	64
38	Interworking unspecified	127	None	Remote procedure error	17	Call set-up or clearing problem	64
39	VPCI/VCI unacceptable	10	None	Remote procedure error	17	Call set-up or clearing problem	64
40	Requested VPCI/VCI not available	35	None	Number busy	1	No logical channel available	71
41	VPCI/VCI assignment failure	36	None	Number busy	1	No logical channel available	71
42	No VPCI/VCI available	45	None	Network congestion	5	No additional information	0
43	User cell rate not available	51	Identified subfield identifier	Network congestion	5	No additional information	0
44	Unsupported combination of traffic parameters	93	None	Remote procedure error	17	Call set-up or clearing problem	64
45	Incompatible destination	88	Incompatible parameters	Incompatible destination	33	No additional information	0
46	AAL parameters cannot be supported	93	None	Remote procedure error	17	Call set-up or clearing problem	64

ITU-T RECOMMENDATIONS SERIES

Series A	Organization of the work of the ITU-T
Series B	Means of expression: definitions, symbols, classification
Series C	General telecommunication statistics
Series D	General tariff principles
Series E	Overall network operation, telephone service, service operation and human factors
Series F	Non-telephone telecommunication services
Series G	Transmission systems and media, digital systems and networks
Series H	Audiovisual and multimedia systems
Series I	Integrated services digital network
Series J	Transmission of television, sound programme and other multimedia signals
Series K	Protection against interference
Series L	Construction, installation and protection of cables and other elements of outside plant
Series M	TMN and network maintenance: international transmission systems, telephone circuits, telegraphy, facsimile and leased circuits
Series N	Maintenance: international sound programme and television transmission circuits
Series O	Specifications of measuring equipment
Series P	Telephone transmission quality, telephone installations, local line networks
Series Q	Switching and signalling
Series R	Telegraph transmission
Series S	Telegraph services terminal equipment
Series T	Terminals for telematic services
Series U	Telegraph switching
Series V	Data communication over the telephone network
Series X	Data networks and open system communication
Series Z	Programming languages