



INTERNATIONAL TELECOMMUNICATION UNION

ITU-T

TELECOMMUNICATION
STANDARDIZATION SECTOR
OF ITU

X.35

(11/93)

**DATA NETWORKS AND OPEN SYSTEM
COMMUNICATIONS**

PUBLIC DATA NETWORKS

**INTERFACE BETWEEN A PSPDN AND A
PRIVATE PSDN WHICH IS BASED ON
X.25 PROCEDURES AND ENHANCEMENTS
TO DEFINE A GATEWAY FUNCTION
THAT IS PROVIDED IN THE PSPDN**

ITU-T Recommendation X.35

(Previously "CCITT Recommendation")

FOREWORD

The ITU-T (Telecommunication Standardization Sector) is a permanent organ of the International Telecommunication Union (ITU). The ITU-T is responsible for studying technical, operating and tariff questions and issuing Recommendations on them with a view to standardizing telecommunications on a worldwide basis..

The World Telecommunication Standardization Conference (WTSC), which meets every four years, establishes the topics for study by the ITU-T Study Groups which, in their turn, produce Recommendations on these topics.

The approval of Recommendations by the Members of the ITU-T is covered by the procedure laid down in WTSC Resolution No. 1 (Helsinki, March 1-12, 1993).

ITU-T Recommendation X.35 was prepared by ITU-T Study Group 7 (1993-1996) and was approved under the WTSC Resolution No. 1 procedure on the 16th of November 1993.

NOTE

In this Recommendation, the expression "Administration" is used for conciseness to indicate both a telecommunication administration and a recognized operating agency.

© ITU 1994

All rights reserved. No part of this publication may be reproduced or utilized in any form or by any means, electronic or mechanical, including photocopying and microfilm, without permission in writing from the ITU.

CONTENTS

	<i>Page</i>
0 Introduction	1
1 Scope	1
2 References	1
3 Definitions	1
4 Abbreviations	2
5 Conformance	2
6 Topologies	3
7 Addressing	6
8 Routing	7
9 An interworking function model	11
10 General considerations	11
11 Procedures for restart	12
12 Procedures for call set-up and clearing	12
13 Procedures for data and interrupt transfer	14
14 Procedures for flow control	14
15 Procedures for reset	14
16 Optional user facilities	15
Annex A – Public/Private Network Interworking using Call Control Mapping	30

SUMMARY

This Recommendation defines the interface and the procedures applicable for the purpose of providing a gateway function in a PSPDN to a private PSDN. This Recommendation has been developed in direct response to a market demand for the PSPDN to provide a mechanism for interconnection between a private and public network on a peer-to-peer basis that does not rely on the provisioning of X.75 STEs in both the private PSDN and the PSPDN. This Recommendation will permit private networks to create Virtual Private Networks (VPNs) across the PSPDNs resources and participate in other features of a PSPDN not available in the private network such as ICUGs.

**INTERFACE BETWEEN A PSPDN AND A PRIVATE PSDN
WHICH IS BASED ON X.25 PROCEDURES AND ENHANCEMENTS
TO DEFINE A GATEWAY FUNCTION THAT IS PROVIDED IN THE PSPDN**

(Geneva, 1993)

0 Introduction

This Recommendation defines the general procedure and interface applicable to interworking between a PSPDN and a Private PSDN based upon modified X.25 procedures to define a gateway function that is provided in the PSPDN. Modification of the procedures defined in X.25 are required for successful completion of calls between a PSPDN and a Private PSDN on a peer-to-peer basis. For clarity and to facilitate interworking between the PSPDN and the Private PSDN, the requirements and examples of actions in the private network have been included.

1 Scope

The scope of this Recommendation is to define the interface and the procedures applicable for the purpose of providing a gateway function in a PSPDN to a Private PSDN.

This Recommendation is only applicable to the interface in the PSPDN that is providing the gateway (i.e. interworking) function to a Private PSDN.

2 References

- Recommendation X.25 *Interface between DTE and DCE terminals operating in the packet mode and connected to public data networks by a dedicated circuit.*
- Recommendation X.75 *Packet Switched Signalling System between public networks providing data transmission services.*
- Recommendation X.110 *International routing principles and routing plan for PSPDNs.*
- Recommendation X.121 *International numbering plan for public data networks.*
- Recommendation X.300 *General principles for interworking between public networks, and between public networks and other networks for the provision of data transmission services.*
- Recommendation X.327 *General arrangements for interworking between Packet Switched Public Data Networks (PSPDNs) and private data networks for the provision of data transmission services.*
- ISO/IEC 8208:1993, *Information technology – Data communications – X.25 packet layer protocol for data terminal equipment.*

3 Definitions

The terms used for all networks and services must be consistent and compatible. Fascicle I.3 contains the terms and definitions applicable to this Recommendation.

4 Abbreviations

CUG	Closed User Group
DCE	Data Circuit Terminating Equipment
DTE	Data Terminal Equipment
IWF	Interworking Function
IWU	Interworking Unit
NUI	Network User Identification
PSDN	Packet Switched Data Network
PSPDN	Packet Switched Public Data Network
PSPvtDN	Packet Switched Private Data Network
ROA	Recognized Operating Agency
TOA/NPI	Type of Address/Numbering Plan Identifier.

5 Conformance

Conformance to this Recommendation can be stated in one of two ways. The first is the case where the PSPDN is providing the DTE like interface to the private PSDN. In this case, to conform to this Recommendation it is necessary that the PSPDN provide a full set of capabilities as described herein including an addressing alternative, routing functionality, an IWU and/or IWF, a complete set of procedures for restart, reset, setup, clearing, interrupt, facility handling, and flow control.

The second is the case where the PSPDN is providing a DCE interface to the private PSDN. In this case, to conform the PSPDN will provide the following as described by section:

Clause 6	At least one of the topologies in Figure 5;
Clause 7	At least item a) with b) and c) being optional;
Subclause 7.1	Either 7.1.1 or 7.1.2;
Subclause 7.2	Optional;
Subclause 7.3	Optional;
Clause 10	Optional;
Clause 11	Optional;
Subclause 12.1	Optional;
Subclause 12.2	This subclause must be supported, however the clearing procedure corresponding to the PSPDN IWF operating as DTE are optional;
Clause 13	Optional;
Clause 14	This clause must be supported;
Clause 15	This clause must be supported, however the reset procedure corresponding to the PSPDN IWF operating as a DTE are optional
Clause 16	Optional.

6 Topologies

Four cases are addressed by this Recommendation (see Figures 1 to 4). The cases differ on what network administers the IWF (PSPDN or PSPvtDN) and the IWF location (i.e. embedded in or detached from the administering network). Furthermore, six PSPDN/PSPvtDN interworking topologies are addressed in this Recommendation. The existence of six topologies is due to the following:

- a) PSPDN/PSPvtDN interworking may be single-link (one link connecting the PSPDN and the PSPvtDN) or multiple-link (more than one link connecting the PSDN and the PSPvtDN) interworking. In a multiple-link interworking, the links' PSPDN end-points may be geographically distant; the same applies to the PSPvtDN end points.
- b) A PSPvtDN may interwork with one PSPDN or concurrently with multiple PSPDNs.
- c) A PSPDN may interwork with PSPvtDN or concurrently with multiple PSPvtDNs.

For all topologies, the only interfaces considered are those using X.25 virtual calls (VCs) and permanent virtual circuits (PVCs) that are established (or preprovisioned) between a PSPDN and a PSPvtDN. All addressing and routing alternatives may not be suitable for all interworking cases or topologies. When appropriate, a note will be included to point out these incompatibilities.

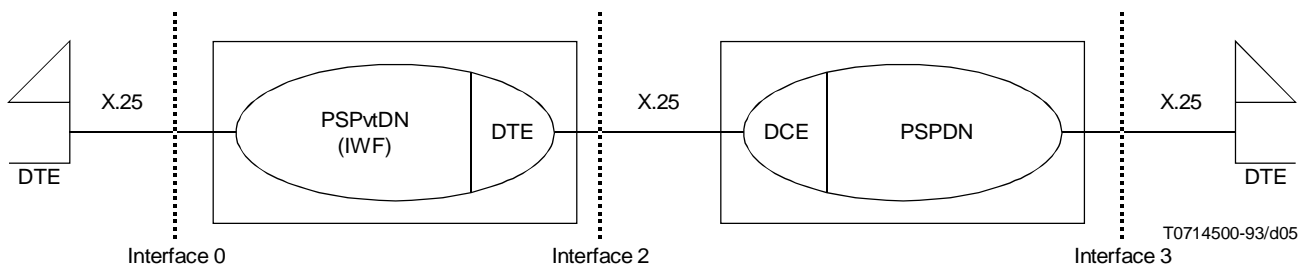

FIGURE 1/X.35

PSPDN/PSPvtDN interworking – Case 1: embedded IWF in the PSPvtDN

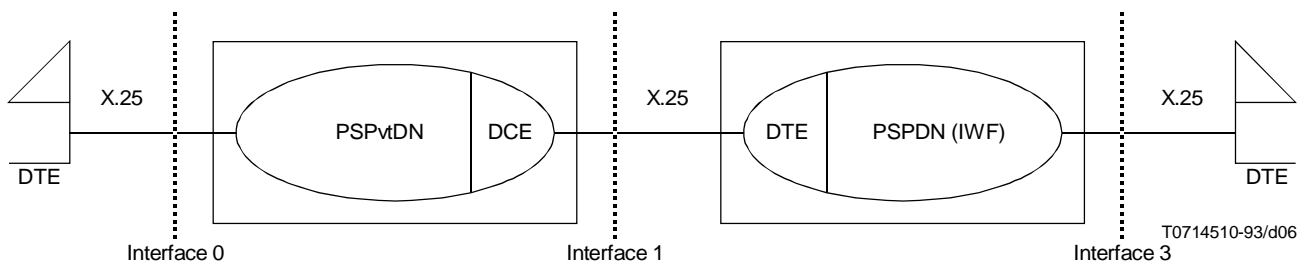

FIGURE 2/X.35

PSPDN/PSPvtDN interworking – Case 2: embedded IWF in the PSPDN



FIGURA 3/X.35

PSPDN/PSPvtDN interworking – Case 3: physically detached IWU administered by the PSPvtDN

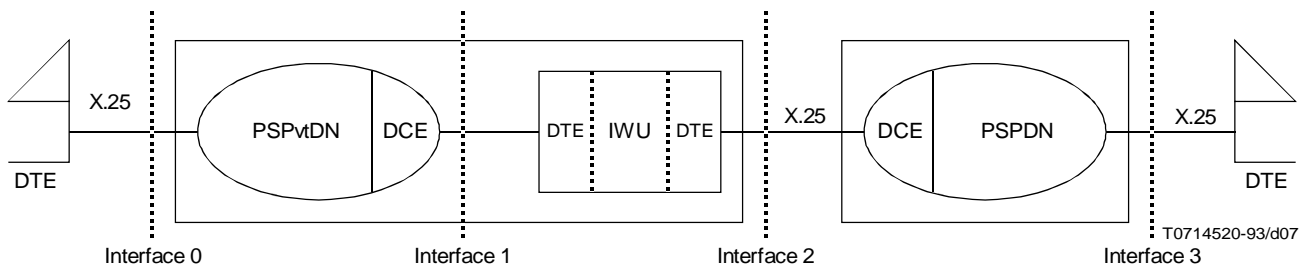
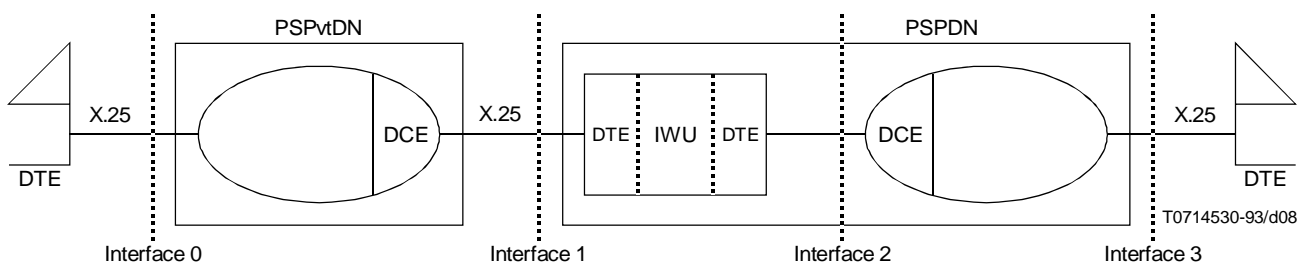

FIGURE 4/X.35

PSPDN/PSPvtDN interworking – Case 4: physically detached IWU administered by the PSPDN

6.1 Topology A

This is the simplest topology. The PSPvtDN is connected to a single PSPDN via one X.25 link. Figure 5 a) illustrates topology A.

6.2 Topology B

The PSPvtDN is connected to a single PSPDN via multiple X.25 links. Figure 5 b) illustrates topology B.

6.3 Topology C

The PSPvtDN is connected to multiple PSPDNs via one X.25 link to each PSPDN. Figure 5 c) illustrates topology C.

6.4 Topology D

The PSPvtDN is connected to multiple PSPDNs via multiple X.25 links to each PSPDN. Figure 5 d) illustrates topology D.

6.5 Topology E

The PSPDN is connected to multiple PSPvtDNs via one X.25 link to each PSPvtDN. Figure 5 e) illustrates topology E.

6.6 Topology F

The PSPDN is connected to multiple PSPvtDNs via multiple X.25 links to each PSPvtDN. Figure 5 f) illustrates topology F.

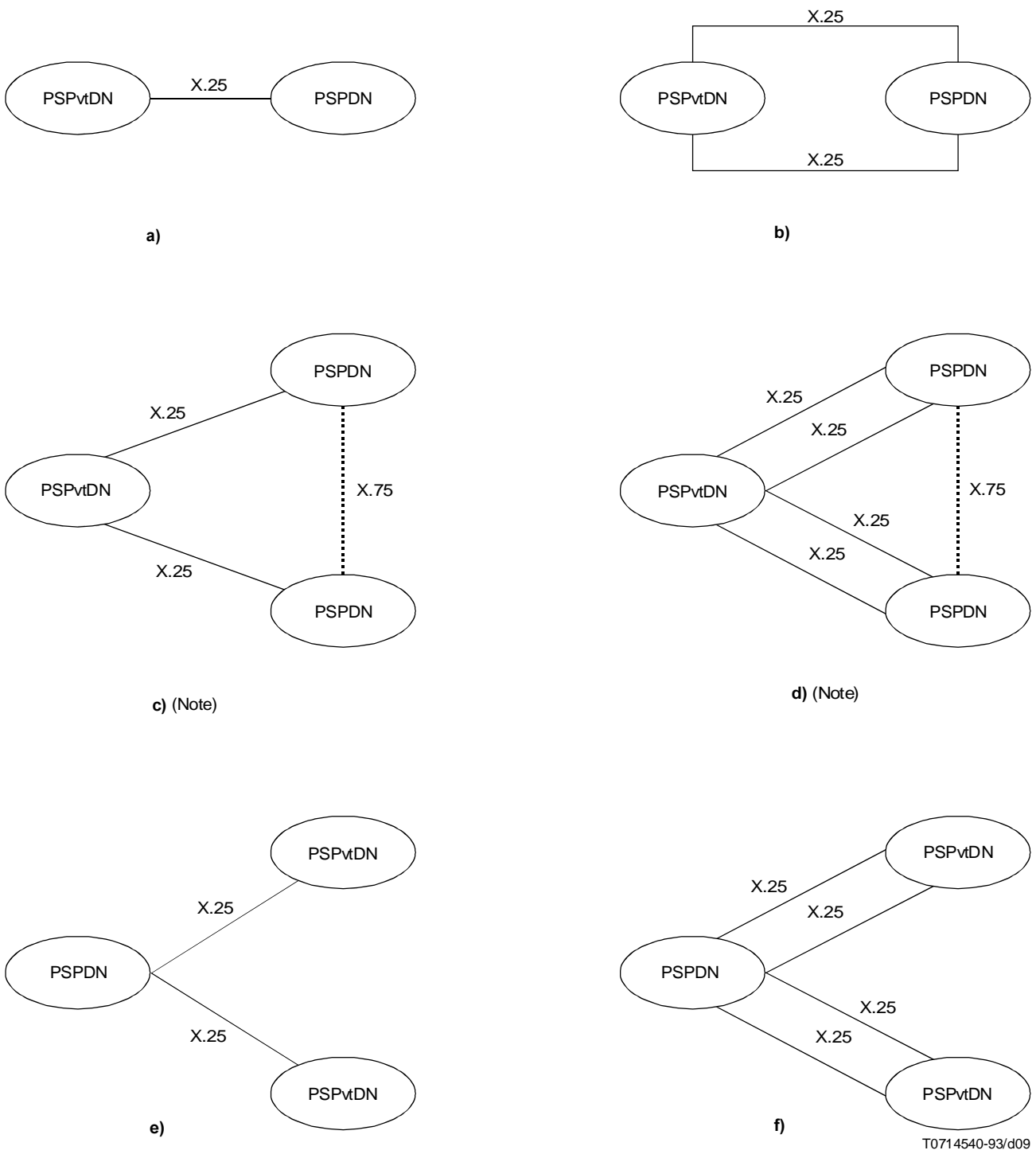

NOTE – PSPvtdNs shall not act as transit networks between two PSPDNs.

FIGURE 5/X.35
PSPDN/PSPvtdN interworking topologies

7 Addressing

There are three PSPvtDN DTE addressing alternatives:

- a) The PSPDN shares its address space with the PSPvtDN DTEs. Each PSPvtDN DTE address is assigned from the PSPDN address space or is one-to-one mapped from a PSPDN address (see 7.1).
- b) The IWF's address is assigned from the PSPDN address space or an IWF identifier is recognized by the PSPDN. PSPvtDN DTEs are not assigned addresses from a PSPDN address space nor mapped from a PSPDN address (see 7.2).
- c) The PSPvtDN DTE addresses are not assigned from a PSPDN address space nor mapped from a PSPDN addressing. No IWF address exists. That is, the PSPvtDN address space is independent (or disjoint) from and PSPDN address space (see 7.3).

Taking into account the existing PSPDN and PSPvtDN environment, backward compatibility considerations, and the ease of implementation, it is recommended that PSPDNs (i.e. IWFs and IWUs under the administration of the PSPDN) support at a minimum addressing alternative a) (see 7.1).

Annex A provides a detailed description of the call flow for different topologies and addressing alternatives.

7.1 PSPDN address space sharing for PSPvtDN DTEs

Under this alternative, a PSPDN shares its X.121 address space with the PSPvtDN. Each PSPvtDN DTE address is one-to-one mapped from a PSPDN address (see 7.1.1) or is assigned from the PSPDN address space (see 7.1.2).

7.1.1 One-to-one PSPvtDN DTE address mapping

A block of PSPDN X.121 addresses is reserved for addressing a PSPvtDN's DTEs by DTEs outside the PSPvtDN. Each of these addresses is mapped one-to-one (by the IWF) into an internal PSPvtDN DTE address (i.e. the address by which the DTE is known to other DTEs inside its PSPvtDN). In this case, a PSPvtDN DTE is known by one address to DTEs inside its PSPvtDN and by a different address¹⁾ to DTEs outside its PSPvtDN. One-to-one mapping options include both mapping a complete X.121 address into an internal PSPvtDN DTE address, or mapping part of an X.121 address (see 7.1.1) into an internal PSPvtDN DTE address.

7.1.2 PSPvtDN addresses from the PSPDN address space

A block of PSPDN X.121 addresses is reserved for assignment to PSPvtDN DTEs. In this case, a DTE on the PSPvtDN is known only by this address (i.e. it is addressed the same way by DTEs on the PSPDN or by other DTEs on its PSPvtDN). Only topologies A, B, E, and F apply to this addressing alternative. However, this does not preclude a PSPvtDN from obtaining addresses from more than one PSPDN.

If the X.121 PSPDN Network Termination Number's (NTN's) address length is less than 10 digits long, the mechanism described in Appendix IV/CCITT Rec. X.25, can be used. That is, additional *complementary address* digits may be reserved to be assigned to a PSPvtDN's DTEs. Each reserved X.121 PSPDN address assigned to a PSPvtDN DTE is divided into two subfields: the first subfield is the X.121 PSPDN address assigned to the PSPvtDN, the second subfield (i.e. the complementary address digits) identifies the PSPvtDN DTE. A limitation is that the number of digits in the two subfields must be 10 or less for international use.

7.2 PSPDN address or identifier assignment for the PSPDN/PSPvtDN IWF

If this alternative is used, then the IWF is assigned a PSPDN address or an identifier recognizable by the PSPDN.

One option is for the IWF PSPDN address to be contained in the called address field of an X.25 call setup/clearing packets. A mechanism to carry the PSPvtDN DTE address must be also be available. One possible mechanism is to carry the PSPvtDN DTE address in the *address extension* facility. When a PSPDN DTE transmits a CALL REQUEST packet to establish a VC with a PSPvtDN DTE, this packet contains an address that identifies the PSPvtDN (e.g. the IWF's

¹⁾ The PSPvtDN DTE may be known by multiple different addresses (one for each PSPDN to which the PSPvtDN is connected).

registered PSPDN address) in the *called address* field, and the PSPvtDN's DTE address in the X.25 *address extension* facility.

7.3 Independent PSPvtDN address space

Under this alternative, all PSPvtDN addresses are independent (i.e. disjoint) from the PSPDN addressing space. That is, an independent PSPvtDN address is one which is not assigned from a PSPDN address space nor mapped from a PSPDN address. No IWF address exists. Two methods exist as described in 7.3.1 and 7.3.2.

7.3.1 Separate DNIC address space from PSPvtDNs

An addressing alternative is described in 1988 CCITT Recommendation X.121. 1988 CCITT Recommendation X.121, Annex B, provides an example, for illustrative purposes only, of a PSPvtDN addressing method. The described alternative requires the allocation of a separate DNIC to be used exclusively for PSPvtDN addressing; the DNIC is shared among multiple PSPvtDNs. Each PSPvtDN is assigned one or more Private Network Identification Code(s) (PNIC). When viewed from the public network, the PNIC, which is up to six digits long, follows the DNIC in the X.25 address field.

7.3.2 PSPvtDN addressing by bilateral agreement

A PSPvtDN, connected to a PSPDN, may have its own particular addressing plan (i.e. its address space is not shared nor assigned by the PSPDN and is not an X.121 or an E.164 address). This requires a bilateral agreement between the PSPDN and the PSPvtDN to ensure that the PSPDN recognizes (and is capable of routing) on these PSPvtDN addresses.

8 Routing

This clause presents the different PSPDN/PSPvtDN interworking routing alternatives considered in this Recommendation. Routing alternatives for VCs where the calling party is a PSPDN DTE are described in clause 8.1 and routing alternatives where the calling party is a PSPvtDN are described in 8.2. Compatible routing/addressing alternative combinations are identified in both subclauses and shown in Table 1.

8.1 PSPDN-to-PSPvtDN routing

This subclause describes three routing alternatives that apply to VCs where the calling party is a PSPDN DTE and the called party is a PSPvtDN DTE. It also addresses other routing issues.

8.1.1 Routing on an X.121 PSPvtDN address

In this case, the calling PSPDN DTE places the X.121 PSPvtDN address in the *called address* field. The PSPDN, upon receiving a CALL REQUEST packet, proceeds to set up the VC route based on the X.121 PSPvtDN address.

The addressing alternatives that are compatible with this routing alternative are those described in 7.1.2, 7.3.1, and 7.3.2 (only if the numbering plan is X.121).

If the 7.1.2 address alternative is used, then the following should be taken into consideration: If the X.121 PSPvtDN DTE addresses are allocated based on the PSPDN X.121 addresses available at the PSPDN/PSPvtDN interworking interface, then the routing of these VCs will be done in an identical manner to the routing of all other VCs. However, if the X.121 addresses are allocated based on some other criteria (e.g. geographical location of the PSPvtDN DTEs) the PSPDN may be required to have additional routing capabilities.

If the 7.3.1 addressing alternative described is used, then the following should be taken into consideration: The PSPDN may not be able to make routing decisions based on the DNIC, since the DNIC only identifies the called DTE as a PSPvtDN DTE. It is possible that the PSPDN is connected directly (or indirectly) to multiple PSPvtDNs, if this is the case, the PSPDN should make routing decisions based on the PNIC digits [i.e. the digits (up to six) that follow the DNIC and uniquely identify the PSPvtDN].

If the 7.3.2 address alternative is used, then the PSPDN will require routing knowledge of the PSPvtDNs addressing plan to route VCs.

TABLE 1/X.35

Compatible Addressing and Routing Alternatives

PSPDN Routing Alternatives	Addressing alternatives				
	PSPDN Address Space Sharing		IWF Address (or Id.) Assigned by PSPDN	Independent PSPvtDN Address Space	
	One-to-one Mapping	PSPvtDN DTE Address from PSPDN		Separate DNIC for PSPvtDNs	Bilateral Agreement
	(4.1.1)	(4.1.2)	(4.2)	(4.3.1)	(4.3.2)
Routing on an X.121 PSPvtDN DTE Address (5.1.1)		✓		✓	✓ ^{a)}
Routing on an IWF Address or Id. (5.1.2)	✓		✓		
Routing on a non-X.121 PSPvtDN DTE Address (5.1.3)					✓
a) Assumes the PSPvtDN addresses are in X.121 format.					

8.1.2 Routing on an IWF address

This alternative describes the case where the calling PSPDN DTE places an X.121 IWF address in the called address field. The PSPDN, upon receiving a CALL REQUEST packet, proceeds to set up the VC route based on the IWF address. The address alternatives that are compatible with this routing alternative are those described in 7.1.1 and 7.2. The called PSPvtDN DTE address may (see 7.2) or may not (see 7.1.1) be contained elsewhere (i.e. not in the called address field) in the call request packet.

If the 7.1.1 addressing alternative is used then the called PSPvtDN DTE address is not contained in the CALL REQUEST packet that the calling PSPDN DTE sends and that a one-to-one mapping occurs between the IWF address and the PSPvtDN DTE address at the PSPDN/PSPvtDN interface.

If the 7.2 addressing alternative is used, then the called PSPvtDN DTE address is contained in the CALL REQUEST packet and may be placed in the called address extension facility (see Annex A for details).

If the 7.1.1 or 7.2 address alternatives are used the routing of the PSPvtDN VC is done in an identical manner to how all other VCs are routed by the PSPDN. That is, no new routing capabilities are required in the PSPDN.

8.1.3 Routing on a non-X.121 PSPvtDN DTE address

This alternative is compatible with the case where the PSPvtDN has an independent address space and the PSPDN routes VCs from its DTEs to the PSPvtDN DTEs based on the PSPvtDN addressing plan.

The PSPvtDN DTE address may be an OSI NSAP address, or a number from some PSPvtDN numbering plan.

This routing alternative is compatible only with PSPvtDN address alternative described in 7.3.2. Since the address is an NSAP or PSPvtDN numbering plan number, then additional routing capabilities are required in the PSPDN.

NOTE – A bilateral agreement between the PSPDN and the PSPvtDN is needed.

8.1.4 Additional issues

This subclause includes a description of other issues related to routing VCs from PSPDN DTEs to PSPvtDN DTEs.

8.1.4.1 Alternate routing

This subclause describes the procedures a PSPDN may follow to alternate route a VC from a calling PSPDN DTE destined for a called PSPvtDN DTE. The alternate routing procedures may take place when a congestion condition or failure occurs at either interface of the PSPDN/PSPvtDN X.25 link. Alternate routing can occur only if the PSPDN/PSPvtDN interworking conforms to topologies B, C, D, or F (see clause 6).

The following subclauses describe potential procedures to alternate route a VC to another PSPDN/PSPvtDN X.25 link. These procedures vary based on the interworking topology and the addressing alternative implemented.

The application of alternative routing procedures when the address alternative defined in 7.3.2 is implemented is for further study.

The following describes for each applicable topology (i.e. B, C, D, and F) and for the corresponding address alternatives a mechanism which can be used to achieve alternate routing. This information does not intend to preclude other non-standard mechanisms for achieving alternate routing.

The following text describes the procedures that must take place on interfaces 1 and 2 (see Figures 3 and 4) to achieve alternate routing in the case of a physically detached IWU.

These procedures are completely symmetrical. The text below describes the procedures to alternate route a VC set-up originating on a calling PSPvtDN DTE and destined for a PSPDN DTE. However, this text also applies for alternate routing of VC set-up originating on a calling PSPDN DTE and destined for a called PSPvtDN DTE (in this case, the references to “interface 1” and “interface 2” and the references to “PSPDN” and “PSPvtDN” must be reversed).

8.1.4.1.1 Topology B

The PSPvtDN and the PSPDN are interconnected with multiple links (e.g. link A, link B, etc.). Figure 6 shows a detailed PSPDN/PSPvtDN interworking (Topology B). All these interfaces are labelled to aid in the following alternate routing discussion. Each link (A and B) has two interfaces (1 and 2).

- *Address alternative A* – If this alternative is implemented, then the PSPvtDN must support the call redirection, call deflection subscription, and call redirection or call deflection notification facilities. The IWU must support the call deflection selection, and call redirection or call deflection notification facilities. The PSPDN support of Hunt Group P facility for INCOMING CALL packets (i.e. the PSPDN must be capable of supporting the receipt of the identical calling address on different X.25 links) is for further study.

Given this facility support, if link 1-A is down, the PSPvtDN must redirect the VC to IWU-B. If link 2 is down, the IWU-A must deflect the VC to IWU-B. For either case, IWU-B must remove and map the address in the call redirection or call deflection notification facility to the called address field in the CALL REQUEST packet²⁾. The PSPDN must accept the CALL REQUEST packet and route it to DTE B.

- *Address alternative B* – The PSPvtDN and the PSPDN facility support is the same as for the topology B – address alternative A. The IWU must only support the call deflection selection facility.

²⁾ Mapping is only required if the addressing alternative described in 7.1.1 applies. If the addressing alternative described in 7.1.2 applies, then no mapping is needed.

Given this facility support, if link 1-A is down, the PSPvtDN must redirect the VC to IWU-B. If link 2-A is down, the IWU-A must remove the called DTE address from the called address extension facility and place it in the called address field of the CALL REQUEST packet. The PSPDN must accept the CALL REQUEST packet and route it to DTE B.

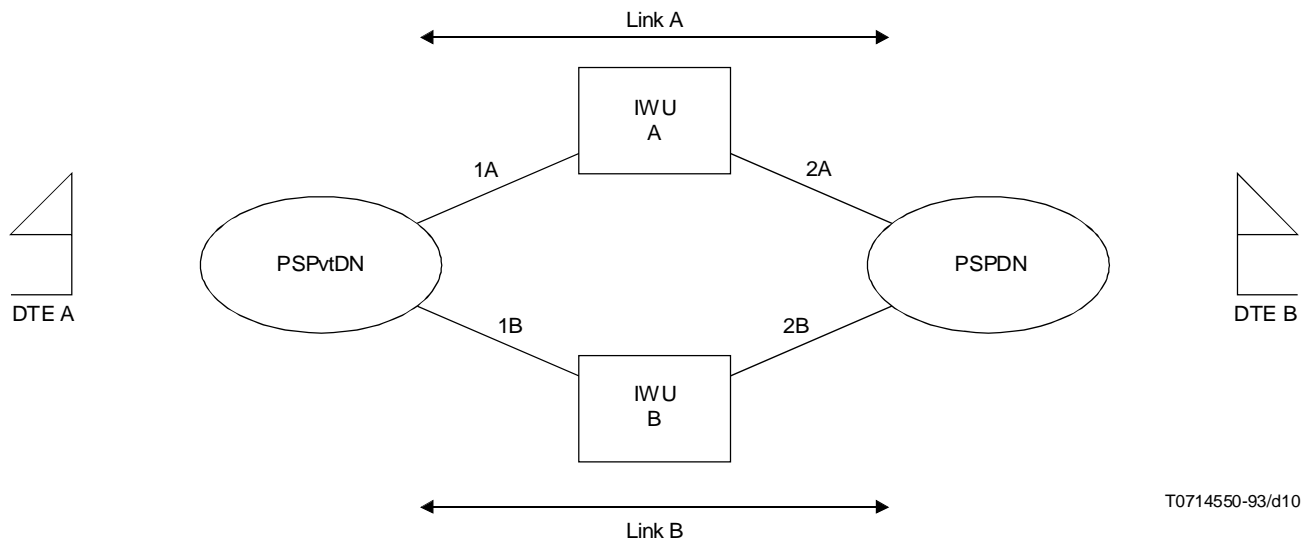

FIGURE 6/X.35
PSPDN/PSPvtDN alternate routing

8.1.4.1.2 Topology C

In this topology multiple links connect the PSPvtDN to different PSPDNs; one link to each PSPDN. Figure 6 applies to this topology except that each link is connected to a different PSPDN.

- *Address alternative A* – The facility support and procedures are the same as for topology B – address alternative A with the exception that the PSPDN need not support the *Hunt Group* facility (because Hunt Groups cannot span multiple networks). As a result, if alternate routing takes place, a calling address will be received by DTE B which will be different to the one that would have been received if the primary link (e.g. link A) had been used to establish the VC.
- *Address alternative B* – The facility support and procedures are the same as for topology B – address alternative B with the Hunt Group exception and calling address limitation as in topology C – address alternative A.

8.1.4.1.3 Topology D

Given that a primary link fails, if the alternate routing is to a link that connects the PSPvtDN to the same PSPDN as the primary link then the description for topology B applies. Otherwise, if the alternate routing is to a link that connects the PSPvtDN to a different PSPDN then the description for topology C applies.

8.1.4.1.4 Topology F

The description for topology B applies.

8.1.4.2 PSPvtDNs as transit networks

A PSPvtDN shall not act as a transit network between two PSPDNs.

8.1.4.3 PSPDNs as transit networks

A PSPDN may act as a transit network between two PSPvtDNs or between another PSPDN and PSPvtDN.

8.2 PSPvtDN-to-PSPDN routing

This subclause presents two possible routing alternatives that apply to VCs where the calling party is a PSPvtDN DTE and the called party is a PSPDN DTE. Other routing alternatives may also be implemented by PSPvtDNs.

8.2.1 Routing on an X.121 PSPDN DTE address

In this case the calling PSPvtDN DTE places the X.121 PSPDN DTE address in the *called address* field. The address alternatives that are compatible with this routing alternative are those described in 7.1.2 and 7.3.1.

8.2.2 Routing on a PSPDN IWF address or identifier

Under this alternative, the PSPvtDN routes VCs destined to a PSPDN DTE based on a PSPDN IWF address (from the PSPvtDN addressing plan) or on an IWF identifier. Address alternatives described in 7.1.1 and 7.2 apply to this routing alternative. The PSPvtDN and IWF procedures for this routing alternative correspond, respectively, to the PSPDN and IWF procedures described in 8.1.2.

9 An interworking function model

The IWF model is based on the model described in ISO/IEC 10028. This Recommendation defines the operation of an intermediate system (IS) model supporting a network service and should be referred to for detailed descriptions. Regardless of whether the IWF is implemented in a detached device (i.e. an IWU) or embedded within a PSPDN or a PSPvtDN, it is providing the functionality of an IS described in the ISO/IEC 10028.

10 General considerations

10.1 Interface types and references

The operation of the IWU is described in terms of its two X.25 interfaces. For ease of reference only, the two interfaces are referred to as “Interface 1” and “Interface 2”. Therefore, in Figures 2 and 3 the words “Interface 1” and “Interface 2” are interchangeable.

The IWU is connected to the PSPDN DCE by a DTE/DCE X.25 interface and is also connected to the PSPvtDN DCE by a DTE/DCE X.25 interface. On both interfaces the IWU is acting as a packet layer X.25 DTE.

The procedures described in this Recommendation are applicable to either interface. In this Recommendation, external events are described in terms of one direction only. For events initiated by the IWU the procedures at both interfaces are described.

NOTE – If the PSPDN is providing a DTE interface to the private network, the link level should conform to ISO/IEC 7776, if providing a DCE interface the link layer should conform to LAPB as described in Recommendation X.25.

10.2 Logical channels

The logical channel identifiers used on one interface of the IWU will not, in general, correspond to those used on the other interface of the IWU. The IWU performs the mapping function between logical channel identifiers on the two interfaces. This mapping is one-to-one and is established during Virtual Call set-up.

10.3 Mapping between dissimilar protocol configurations

Mapping between packets received on interface 1 might not be on a one-to-one basis to those transmitted on Interface 2 due to the differences which are possible within ISO/IEC 8208. In addition, certain flow control parameters such as packet size and window size requested from one interface might also be different from the other interface as a result of negotiation.

11 Procedures for restart

11.1 Interface restart not initiated by the IWU

When receiving a RESTART INDICATION packet on Interface 1, the IWU confirms this restart by sending a RESTART CONFIRMATION packet across Interface 1 according to the procedures in 4.3 of ISO/IEC 8208.

For each Virtual Call, if any, that had existed on Interface 1, the IWU initiates clearing procedures on Interface 2. The Clearing Cause Field is set to either "00000000" or "10000000" as indicated in Table 5 of ISO/IEC 8208.

11.2 Interface restart initiated by the IWU

To restart Interface 1, the IWU transmits a RESTART REQUEST packet as specified in 4.1 of ISO/IEC 8208.

The restarting cause code to be used is given in Table 7 of ISO/IEC 8208.

For each Virtual Call, if any, that had existed on Interface 1, the IWU initiates clearing procedures on Interface 2.

12 Procedures for call set-up and clearing

12.1 Virtual call set-up

12.1.1 Virtual call initiation

When the IWU receives an INCOMING CALL packet on Interface 1, it

- a) determines the remote interface (Interface 2);
- b) matches window sizes and packet sizes for Interface 1 (implied by default or explicitly requested in the INCOMING CALL packet) to those available on Interface 2 (available by default or through negotiation if allowed on the interface);

NOTE 1 – If the IWU does not have segmentation and reassembly capabilities, the IWU should ensure that the maximum DATA packet size on each interface is identical. If the packet sizes on Interface 1 and Interface 2 are dissimilar, the IWU should clear the call. If the IWU does have segmentation and reassembly capabilities, then the relationship of packet sizes on the two interfaces is a result of IWU action during Virtual Call set-up;

- c) matches optional user facilities requested from Interface 1 to those available on Interface 2;
- d) selects a free logical channel on Interface 2, and
- e) transmits a CALL REQUEST packet across Interface 2.

If any anomalies result from the above procedures (e.g. no logical channel allowing outgoing access available on Interface 2, or requested facilities not being available on Interface 2), the IWU clears the call on Interface 1. A CALL REQUEST is not transmitted on Interface 2 in this case.

NOTE 2 – Where the data link layer is not already active at an interface, the IWU shall establish a data link connection using procedures appropriate to that interface, for example according to ISO 7776.

12.1.2 Virtual call response

12.1.2.1 Successful call response

If the IWU receives a CALL CONNECTED packet on Interface 2 as a result of having transmitted a CALL REQUEST packet on that interface, it transmits a CALL ACCEPTED packet on the logical channel corresponding to the original INCOMING CALL packet on Interface 1.

12.1.2.2 Unsuccessful call response

If the IWU receives a CLEAR INDICATION packet on Interface 2 as a result of having transmitted a CALL REQUEST packet on Interface 2, it

- a) follows the procedures of 5.5.2 of ISO/IEC 8208 for responding to a CLEAR INDICATION packet on Interface 2;
- b) performs a clearing procedure on the logical channel corresponding to the original INCOMING CALL packet on Interface 1.

Details of the clearing cause and diagnostic codes to be transmitted on Interface 1 are given in Annex A of ISO/IEC 8208.

12.2 Virtual call clearing

It is recommended that CLEAR procedures are implemented in the IWF in such a way that they have end-to-end significance. The following convention has been established for clearing cause codes as governed by Figures 1, 2, 3, and 4:

Figure 1:

Public DTE Clear:	HEX 00 or 1XXXXXXXX
PSPDN Clear:	CCITT X.25 Cause Codes
PSPvtDN IWF to PSPDN:	Bit 8 = 1 with CCITT Cause Codes in bits 7-1
PSPvtDN DTE Clear:	HEX 00 or 10000000
PSPvtDN to PSPvtDN DTE:	CCITT X.25 Cause Codes

Figure 2:

PSPDN DTE Clear:	HEX 00 or 1XXXXXXXX
PSPDN IWF (or DTE) Clear:	Bit 8 = 1 with CCITT Cause Codes in bits 7-1
PSPvtDN DCE Clear:	CCITT X.25 Cause Codes
PSPvtDN DTE Clear:	HEX 00 or 10000000

Figure 3:

PSPDN DTE Clear:	HEX 00 or 1XXXXXXXX
PSPDN DCE Clear:	CCITT X.25 Cause Codes
PSPvtDN DCE Clear:	CCITT X.25 Cause Codes
IWU Clear:	Bit 8 = 1 with CCITT Cause Codes in bits 7-1

NOTE – When CCITT Clear Causes are to be passed through the IWU, bit 8 is changed by the IWU from 0 to 1, i.e. CCITT Cause Codes with bit 8 = 1.

Figure 4:

PSPDN DTE Clear:	0000000 or 1XXXXXXXX
PSPDN DCE Clear:	CCITT X.25 Cause Codes
PSPvtDN DTE Clear:	0000000 or 10000000
PSPvtDN DCE Clear:	CCITT X.25 Cause Codes to PSPDN DTE
IWU Clear:	Bit 8 = 1 with CCITT Cause Codes in bits 7-1
IWU (DTE):	Converts CCITT X.25 Cause Codes from bit 8 = 0 to bit 8 = 1
IWU (DTE):	Passes Causes HEX 00 and 1XXXXXXXX unchanged in both directions

The clearing cause codes defined in Table 5 of ISO/IEC 8208 (with bit 8 set to 1) are used. The diagnostic codes defined in Table 25 of ISO/IEC 8208 are used.

If the Virtual Call is associated with a logical channel of Interface 2, the IWU also initiates clearing procedures on Interface 2.

13 Procedures for data and interrupt transfer

13.1 Procedures for data transfer

The aspects of data transfer, which are given in clause 6 of ISO/IEC 8208, relevant to IWU operation are:

- a) Maximum User Data Field size of the two interfaces and the need to perform segmentation and reassembly using the M-bit (see 6.2 and 6.4 of ISO/IEC 8208); and
- b) Integrity of complete packet sequences, including the setting of the D-bit and Q-bit (see 6.3, 6.5, and 6.6 of ISO/IEC 8208) in each DATA packet.

13.2 Procedures for interrupt

When the IWU receives an INTERRUPT packet on Interface 1, it follows the procedures indicated in 6.8.2 of ISO/IEC 8208. The Interrupt User Data carried in the INTERRUPT packet received on Interface 1 is transmitted in an INTERRUPT packet on Interface 2 following the procedures for Interrupt Transmission specified in 6.8.1 of ISO/IEC 8208.

When the IWU receives an INTERRUPT CONFIRMATION packet on Interface 2 having previously transmitted an INTERRUPT packet on that interface, the IWU transmits an INTERRUPT CONFIRMATION packet on Interface 1 as specified in 6.8.3 of ISO/IEC 8208.

NOTES

- 1 In the case where the PSPDN provides a DTE interface to the private network, this particular DTE interface is not required to support a T26 Interrupt timer.
- 2 The procedures for error conditions associated with interrupt are defined in 6.8.2 of ISO/IEC 8208.

14 Procedures for flow control

The aspects of flow control, which are given in clause 7 of ISO/IEC 8208, relevant to IWU operation are:

- a) The flow control procedures exercised on one interface may be independent of those exercised on the other interface.
- b) Receipt of a DATA packet with the D-bit set to 1 should not result in window rotation on Interface 1 until rotation of the window of Interface 2 for all the user data in the originally received DATA packet.

15 Procedures for reset

After a VC reset, data packets may remain in the IWU buffers. In this case, the IWU may follow the procedures described in clause 9 of ISO/IEC 8208 to determine what action to take with respect to these remaining packets.

15.1 It is recommended that RESET procedures are implemented in the IWF in such a way that they have end-to-end significance. The following convention has been established for RESETing cause codes as governed by Figures 1, 2, 3, and 4:

Figure 1:

Public DTE RESET:	HEX 00 or 1XXXXXXXX
PSPDN RESET:	CCITT X.25 Cause Codes
PSPvtDN IWF to PSPDN:	Bit 8 = 1 with CCITT Cause Codes in bits 7-1
PSPvtDN DTE RESET:	HEX 00 or 10000000
PSPvtDN to PSPvtDN DTE:	CCITT X.25 Cause Codes

Figure 2:

PSPDN DTE RESET:	HEX 00 or 1XXXXXXXX
PSPDN IWF (or DTE) RESET:	Bit 8 = 1 with CCITT Cause Codes in bits 7-1
PSPvtDN DCE RESET:	CCITT X.25 Cause Codes
PSPvtDN DTE RESET:	HEX 00 or 10000000

Figure 3:

PSPDN DTE RESET:	HEX 00 or 1XXXXXXXX
PSPDN DCE RESET:	CCITT X.25 Cause Codes
PSPvtDN DCE RESET:	CCITT X.25 Cause Codes
IWU RESET:	Bit 8 = 1 with CCITT Cause Codes in bits 7-1

NOTE – When CCITT RESET Causes are to be passed through the IWU, bit 8 is changed by the IWU from 0 to 1, i.e. CCITT Cause Codes with bit 8 = 1.

Figure 4:

PSPDN DTE RESET:	00000000 or 1XXXXXXXX
PSPDN DCE RESET:	CCITT X.25 Cause Codes
PSPvtDN DTE RESET:	00000000 or 10000000
PSPvtDN DCE RESET:	CCITT X.25 Cause Codes to PSPDN DTE
IWU RESET:	Bit 8 = 1 with CCITT Cause Codes in bits 7-1
IWU (DTE):	Converts CCITT X.25 Cause Codes from bit 8 = 0 to bit 8 = 1
IWU (DTE):	Passes Causes HEX 00 and 1XXXXXXXX unchanged in both directions

The resetting cause codes defined in Table 6 of ISO/IEC 8208 (with bit 8 set to 1) are used. The diagnostic codes defined in Table 25 of ISO/IEC 8208 are used. The IWU buffers subsequent User Data received after the resetting of Interface 1 is complete but before the resetting of Interface 2 is completed.

16 Optional user facilities

This clause describes user facilities in the context of PSPDN/PSPvtDN interworking.

When subscribing to a PSPDN interface, the IWU needs to subscribe to the proper X.25 optional user facilities (see Annex A of ISO/IEC 8208). It is necessary for the IWU to have knowledge of the administrative arrangements of the PSPDN and PSPvtDN with which it interworks. In this regard, the IWU is asymmetrical with respect to the two interfaces (as distinct from the general procedures described earlier). The IWU gains this knowledge by local administrative arrangements, or by use of the On-line Facility Registration facility.

For the purpose of PSPDN/PSPvtDN interworking, CCITT X.25 facilities can be categorized into three groups based on the impact that transmitting them over (or subscribing to them at) Interfaces 1 and/or 2 has on achieving transparent end-to-end VC set-up and data transfer:

- 1) *Group 1* – Facilities which will affect the capability to set up or transfer data over PSPDN/PSPvtDN VCs. These facilities are:
 - Subscription facilities:
 - Incoming calls barred;
 - Outgoing call barred;
 - Default throughput class assignment;
 - Throughput class negotiation;
 - Closed user group;
 - Closed user group with outgoing access;
 - Closed user group with incoming access;
 - Incoming call barred within a closed user group;
 - Outgoing call barred within a closed user group;

- Bilateral closed user group;
- Bilateral closed user group with outgoing access;
- Fast select acceptance;
- Reverse charging acceptance;
- Local charging prevention;
- NUI subscription;
- NUI override;
- Charging Information;
- ROA subscription;
- Call deflection subscription;
- TOA/NPI address subscription.
- Per-call facilities:
 - Transit Delay selection and indication;
 - Throughput class negotiation;
 - Closed user group selection;
 - Closed user group with outgoing access selection;
 - Bilateral closed user group selection;
 - Fast select;
 - Reverse charging;
 - NUI selection;
 - ROA selection;
 - Call redirection or call deflection notification;
 - Called line address modified notification;
 - Call deflection selection;
 - Charging Information;
 - ITU-T specified DTE facilities.

Table 2 illustrates how a facility may affect the ability to set up or transfer data at Interfaces 0 and/or 3 if it is transmitted over/subscribed to at interfaces 1 and/or 2, and what action must be taken at Interfaces 1 and/or 2 if a facility is transmitted over/subscribed to at Interfaces 0 and/or 3 to ensure end-to-end transparency.

- 2) *Group 2* – Facilities which will not impact the capability to set up or transfer data on PSPDN/PSPvtDN VCs, but if supported appropriately may enhance the VC's performance. These facilities are:
- Subscription facilities:
 - D-bit modification;
 - Non-standard default packet sizes;
 - Non-standard default window sizes;
 - Flow control parameter negotiation;
 - Hunt Group;
 - Call redirection.
 - Per-call facilities:
 - Flow control parameter negotiation.

- 3) *Group 3* – Facilities which will not impact the capability to set up and transfer data on PSPDN/PSPvtDN VCs. These facilities are:
- Subscription facilities:
 - On-line facility registration;
 - Extended packet sequence numbering (module 128);
 - Packet retransmission;
 - One-way logical channel outgoing;
 - One-way logical channel incoming.

Table 3 describes the need for passing facilities in certain packet types (similar to Table 29/X.25). This functionality is needed for PSPDN and PSPvtDN interworking.

TABLE 2/X.35

IWU Facility Handling

Facility	Affects at interface 0 and/or 3 if a facility is transmitted over/subscribed to at interfaces 1 and/or 2	Action must be taken at interface 1 and/or 2 to insure end-to-end transparency if a facility is transmitted over/subscribed to at interfaces 0 and/or 3
Incoming Calls Barred	Calls will be cleared	No actions needed
Outgoing Calls Barred	Calls will be cleared	No actions needed
Default Throughput Class Assignment	Lower TPC values may be negotiated	Subscribe the same value(s)
Throughput Class Negotiation	Lower TPC values may be negotiated	Transmit the same value(s)
Closed User Group	Calls will be cleared if not subscribed	Subscribe the same facility
CUG with Outgoing Access	No impact	Subscribe the same facility
CUG with Incoming Access	Calls will be cleared if not subscribed	Subscribe the same facility
Incoming Calls Barred within a CUG	No impact	No actions needed
Outgoing Calls Barred within a CUG	No impact	No actions needed
Bilateral CUG	Calls will be cleared if not subscribed	Subscribe the same facility
Bilateral CUG with Outgoing Access	No impact	No actions needed
Fast Select Acceptance	Calls will be cleared if not subscribed	Subscribe the same facility
Reverse Charging Acceptance	Calls will be cleared if not subscribed	Subscribe the same facility
Local Charging Prevention	Calls will be cleared if not subscribed	No actions needed

TABLE 2/X.35 (end)

IWU Facility Handling

Facility	Affects at interface 0 and/or 3 if a facility is transmitted over/subscribed to at interfaces 1 and/or 2	Action must be taken at interface 1 and/or 2 to insure end-to-end transparency if a facility is transmitted over/subscribed to at interfaces 0 and/or 3
NUI Subscription	Calls will be cleared if not subscribed	Subscribe the same facility
NUI Override	Calls will be cleared if not subscribed	Subscribe the same facility
Charging Information	Calls will be cleared if not subscribed or transmitted	Subscribe or transmit the same facility
ROA Subscription	Calls will be cleared if not subscribed or different ROA is selected	Subscribe the same facility
Call Deflection Subscription	Calls will be cleared if not subscribed	Subscribe the same facility
TOA/NPI Address Subscription	Calls will be cleared if not subscribed	Subscribe the same facility
Transit Delay Selection and Indication	No impact	Transmit the same facility
CUG Selection	Calls will be cleared if CUG is not subscribed	Transmit the same facility Subscribe CUG-related facility
CUG with Outgoing Access Selection	Calls will be cleared if not subscribed	Transmit the same facility Subscribe CUG-related facility
Bilateral CUG Selection	Calls will be cleared if not subscribed	Transmit the same facility Subscribe Bilateral CUG facility
Fast Select	Calls will be cleared if the called DTE does not subscribe FS acceptance	Transmit the same facility Subscribe FS Acceptance Facility
Reverse Charging	Calls will be cleared if the called DTE does not subscribe RC Acceptance	Transmit the same facility Subscribe RC Acceptance Facility
NUI Selection	Calls will be cleared if NUI is not supported	Transmit NUI facility Subscribe NUI facility
ROA Selection	No impact	Transmit the same facility
CRCDN	No impact	Transmit the same facility Subscribe CRCD-related facility
CLAMN	No impact	Transmit the same facility
Call Deflection Selection	Calls will be cleared if CD facility is not subscribed	Transmit the same facility Subscribe CD facility
ITU-T Specified DTE Facilities	Calls will be cleared if not subscribed	Transmit the same facility

TABLE 3/X.35

Packet types in which the facility may be present

Facility	Call Request	Incoming Call	Call Accepted	Call Connected	Clear Request	Clear Indication	DCE Clear Confirmation
Flow control parameter negotiations	X	X	X	X			
Throughput class negotiations	X	X	X	X			
Closed user group selection	X	X					
Closed user group with outgoing access selection	X	X					
Bilateral closed user group selection	X	X					
Reverse charging	X	X					
Fast select	X	X					
NUI selection	X	X (Note 2)	X (Note 1)	X (Note 2)			
Charging information – requesting service – receiving information	X	X (Note 2)	X	X (Note 2)		X	X
ROA selection	X	X (Note 2)					
Call deflection selection					X (Note 4)	X (Note 2)	
Call redirection or deflection notification	X (Note 2)	X					
Call line address modified notification			X (Note 3)	X	X (Notes 3 and 4)	X	
Transit delay selection and indication	X	X	X (Note 2)	X			
Marker	X	X	X	X	X	X	

NOTES

- 1 This facility code and associated facility parameter may be present in a CALL ACCEPTED packet only in conjunction with the NUI subscription facility.
- 2 May be required for interworking between PSPDNs and PSPvtDNs via an X.25 link when the PSPDN assumes the non-traditional role of providing a DTE interface.
- 3 Only when the reason “Called DTE originated” is used in the parameter field.
- 4 The DTE is not allowed to use both *call deflection selection* and *call line address modified notification* facilities in the same CLEAR REQUEST packet.

16.1 Additional considerations

16.1.1 Transit delay

The values of the Transit Delay Selection and Indication and the End-to-End Transit Delay Negotiation facilities may be modified by the IWU to reflect the transit delay introduced by the PSPvtDN and/or the IWU itself. If the total delay then exceeds the maximum acceptable transit delay value, if specified by the remote calling DTE in the End-to-End Transit Delay Negotiation Facility, then IWU clears the Virtual Call.

16.1.2 Closed user group related facilities

Figure 7 in conjunction with Table 4 depicts the treatment of calls in relation to the handling of CUGs in the PSPDN. For a PSPvtDN to support CUGs involving its DTEs and PSPDN DTEs, the PSPvtDN must subscribe to the appropriate CUG-related facilities at its interface to the PSPDN. Table 4 shows all possible types of CUG-related facilities that a PSPvtDN can subscribe to and, as a function of this, the different types of CUG-related facility subscriptions it can offer to its DTEs that need to belong to CUGs that involve PSPDN DTEs. For example, if a PSPvtDN subscribes to the *CUG/OA with preferential facility* at the PSPDN interface, then the PSPvtDN will only be able to offer its DTEs *CUG/OA with preferential facility* subscription for CUGs that involve PSPDN DTEs.

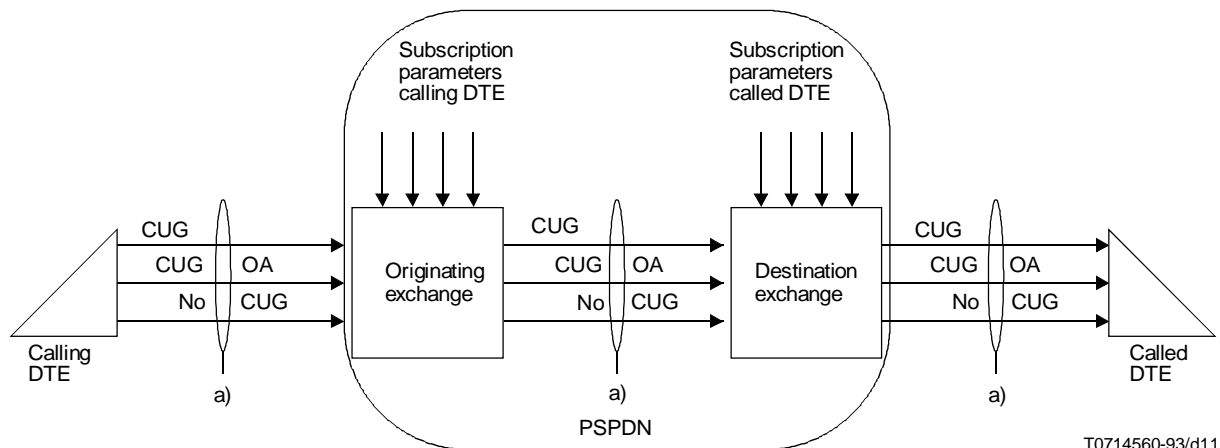

CUG OA Closed user group with outgoing access

^{a)} Possible different signals regarding CUG.

FIGURE 7/X.35

Treatment of Calls in Relation to CUG

TABLE 4/X.35

PSPvtDN CUG-Related Facility Subscription Options at the PSPDN Interface

Signalled by the calling DTE in the call request phase (Note 1)	CUG selection facility	CUG/OA selection facility	No CUG nor CUG/OA selection facility
Subscription of the called DTE			
CUG with preferential (Note 2)	CUG facility (CUG specified) (Note 3)	Not allowed (call cleared)	CUG facility (Preferential CUG) (Note 3)
CUG/OA with preferential	CUG/OA facility (CUG specified) (Note 3)	Not allowed (call cleared)	CUG/OA facility (Preferential CUG) (Note 4)
CUG/IA with preferential	CUG facility (CUG specified) (Note 3)	Not allowed (call cleared)	CUG facility (Preferential CUG) (Note 3)
CUG/IA/OA with preferential	CUG/OA facility (CUG specified) (Note 3)	Not allowed (call cleared)	CUG/OA facility (Preferential CUG) (Note 4)
CUG/OA without preferential	CUG facility (CUG specified) (Note 3)	CUG/OA facility (CUG specified) (Note 4)	No CUG nor CUG/OA facility
CUG/IA without preferential	CUG facility (CUG specified) (Note 3)	Not allowed (call cleared)	Not allowed (call cleared)
CUG/IA/OA without preferential	CUG facility (CUG specified) (Note 3)	CUG/OA facility (CUG specified) (Note 4)	No CUG nor CUG/OA facility
No CUG	Not allowed (call cleared)	Not allowed (call cleared)	No CUG nor CUG/OA facility

TABLE 4/X.35 (end)

PSPvtDN CUG-Related Facility Subscription Options at the PSPDN Interface

Signalled from the network to the destination exchange in the call request phase Subscription of the called DTE	CUG utility	CUG/OA utility	No CUG nor CUG/OA utility
CUG with preferential (Note 5)	CUG selection facility (CUG specified) (Notes 6, 7 and 8)	CUG selection facility (CUG specified) (Notes 6, 7 and 8)	Access barred (call cleared)
CUG/OA with preferential	CUG selection facility (CUG specified) (Notes 6, 7 and 8)	CUG sel fac. (CUG specified) (Notes 6, 7 and 8)	Access barred (call cleared)
CUG/IA with preferential	CUG selection facility (CUG specified) (Notes 6, 7 and 8)	CUG selection facility (CUG specified) (Notes 6, 7 and 8)	No CUG nor CUG/OA selection facility
CUG/IA/OA with preferential	CUG selection facility (CUG specified) (Notes 6, 7 and 8)	CUG selection facility (CUG specified) (Notes 6, 7 and 8)	No CUG nor CUG/OA selection facility
CUG/OA without preferential	CUG selection facility (CUG specified) (Notes 6 and 7)	CUG selection facility (CUG specified) (Notes 6 and 7)	Access barred (call cleared)
CUG/IA without preferential	CUG selection facility (CUG specified) (Notes 6 and 7)	CUG/OA selection facility (CUG specified) (Notes 6 and 7)	No CUG nor CUG/OA selection facility
CUG/IA/OA without preferential	CUG selection facility (CUG specified) (Notes 6 and 7)	CUG/OA selection facility (CUG specified) (Notes 9 and 10)	No CUG nor CUG/OA selection facility
No CUG	Access barred (call cleared)	No CUG nor CUG/OA selection facility	No CUG nor CUG/OA selection facility
<p>IA Incoming access OA Outgoing access</p> <p>NOTES</p> <p>1 The inclusion of both CUG and CUG/OA selection facilities is not allowed in the call request phase.</p> <p>2 CUG without preferential it not allowed.</p> <p>3 If outgoing calls are barred within the preferential, specified CUG or only CUG then the call is cleared.</p> <p>4 If outgoing calls are barred within the preferential, specified CUG or only CUG then only outgoing access applies. No CUG is signalled into the network.</p> <p>5 CUG without preferential is not allowed.</p> <p>6 If the CUG specified to the destination exchange is not subscribed to by the called DTE, the call is blocked.</p> <p>7 If incoming calls are barred within the specified CUG, the call is blocked.</p> <p>8 If the specified CUG is the preferential CUG, the incoming call may contain no CUG or CUG/OA facility.</p> <p>9 If the CUG specified to the destination exchange is not subscribed to by the called DTE, Incoming Access applies; the incoming call contains no CUG nor CUG/OA selection facility.</p> <p>10 If incoming calls are barred within the specified CUG, Incoming Access applies; the incoming call contains no CUG or CUG/OA selection facility.</p>			

As shown in Table 4, if the PSPDN supports the *Closed User Group with Incoming Access* and *Closed User Group with Outgoing Access (CUG IA/OA) without preferential* facilities then the PSPvtDN should subscribe to these facilities. The PSPvtDN should register at the PSPDN interface all CUGs that involve its DTEs and PSPDN DTEs. Furthermore, for CUGs involving its DTEs and PSPDN DTEs, the PSPvtDN's CUG indexing must either be identical to the PSPDN's CUG indexing, or otherwise, the appropriate CUG index mapping should take place. The appropriate subscription (i.e. CUG IA/OA), CUG registrations, and CUG indexing will permit the PSPvtDN to support any CUG-related facility.

Note that CUG-related facilities supported by a PSPvtDN for CUGs that involve only PSPvtDN DTEs is independent of the CUG-related facilities that a PSPvtDN subscribes to at the PSPDN interface.

In the case of PSPDN/PSPvtDN interworking using an IWU external to the PSPvtDN (see Figure 2), the IWU should subscribe to CUG IA/OA without preferential at both the PSPDN and PSPvtDN interfaces. All CUG facilities should be passed transparently through the IWU with the exception that, if needed, the appropriate CUG index mapping can take place.

16.1.3 Network user identifier

NOTE – The description of how an NUI is transmitted over a PSPDN/PSPvtDN X.25 link is for further study.

16.1.4 Call deflection selection facility

The octet following the Facility Code Field indicates the length of the Facility Parameter Field in octets. It has the value $n + 2$, where n is the number of octets necessary to hold the called address of the DTE to which the call is to be deflected (the alternate DTE).

The first octet of the Facility Parameter field indicates the reason for deflecting the call. The coding of this octet is:

<i>Bits</i>	<i>Reason</i>
8 7 6 5 4 3 2 1	
1 1 0 0 0 0 0 0	Call deflection by the originally-called DTE or Call deflection by gateway as a result of call deflection by the originally-called DTE ³⁾
1 1 0 0 0 0 0 1	Call deflection by gateway as a result of call redirection due to originally-called DTE busy ³⁾
1 1 0 0 1 0 0 1	Call deflection by gateway as a result of call redirection due to originally-called DTE out of order ³⁾
1 1 0 0 1 1 1 1	Call deflection by gateway as a result of call redirection due to prior request from originally-called DTE for systematic call redirection ³⁾

NOTE – These codes are passed transparently to the DTE to which the call is deflected (via the Call Redirection or Call Deflection Notification facility) and to the calling DTE (via the Called Line Address Modified Notification facility). If bits 8 and 7 are not set to 1 by the called DTE, they are forced to this value by the DCE.

The second octet of the Facility Parameter Field indicates the number of digits in the alternate DTE address. This address length indicator is binary-coded, where bit 1 is the low-order bit. Its value does not exceed 15.

The following octets contain the alternate DTE address. Each digit of the address is coded in a semi-octet in binary-coded decimal, where bit 5 or 1 is the low-order bit of the digit.

Starting from the high-order digit of the address, the address is coded in octet 3 and consecutive octets of the Facility Parameter Field, with two digits per octet. In each octet, the higher-order digit is coded in bits 8, 7, 6, and 5.

When the number of semi-octets of the alternate DTE address is odd, a semi-octet with zeros in bits 4, 3, 2 and 1 is inserted after the last semi-octet in order to maintain octet alignment.

³⁾ Applies where the originally-called DTE is on a private network and the private network gateway to the public network that presented the incoming call deflects the call so that the private network is no longer involved with the call.

16.1.5 Call redirection or call deflection notification facility

The octet following the Facility Code Field indicates the length in octets of the Facility Parameter Field and has the value $n + 2$, where n is the number of octets necessary to hold the originally-called DTE address.

The first octet of the Facility Parameter Field indicates the reason for the call redirection or call deflection. The coding of this octet is:

<i>Bits</i>	<i>Reason</i>
8 7 6 5 4 3 2 1	
0 0 0 0 0 0 0 1	Call redirection due to originally-called DTE busy ⁴⁾
0 0 0 0 0 1 1 1	Call distribution within a hunt group ⁵⁾
0 0 0 0 1 0 0 1	Call redirection due to originally-called DTE out of order ⁴⁾
0 0 0 0 1 1 1 1	Call redirection due to prior request from originally-called DTE for systematic call redirection ⁴⁾
1 0 0 0 0 0 0 0	Call deflection by the originally-called DTE ^{6), 7)}
1 0 0 0 0 0 0 1	Call redirection due to originally-called DTE busy ⁶⁾
1 0 0 0 1 0 0 1	Call redirection due to originally-called DTE out of order ⁶⁾
1 0 0 0 1 1 1 1	Call redirection due to prior request from originally-called DTE for systematic call redirection ⁶⁾
1 1 0 0 0 0 0 0	Call deflection by the originally-called DTE ⁷⁾ or Call deflection by gateway as a result of call deflection by the originally-called DTE ^{7), 8)}
1 1 0 0 0 0 0 1	Call deflection by gateway as a result of call redirection due to originally-called DTE busy ^{7), 8)}
1 1 0 0 1 0 0 1	Call deflection by gateway as a result of call redirection due to originally-called DTE out of order ^{7), 8)}
1 1 0 0 1 1 1 1	Call deflection by gateway as a result of call redirection due to prior request from originally-called DTE for systematic call redirection ^{7), 8)}

The second octet of the Facility Parameter Field indicates the number of digits in the originally-called DTE address. This address-length indicator is binary-coded, where bit 1 is the low-order bit. Its value does not exceed 15.

The following octets contain the originally-called DTE address. Each digit of the address is coded in a semi-octet in binary-coded decimal, where bit 5 or 1 is the low-order bit of the digit.

Starting from the high-order digit of the address, the address is coded in octet 3 and consecutive octets of the Facility Parameter Field, with two digits per octet. In each octet, the higher-order digit is coded in bits 8, 7, 6, and 5.

When the number of semi-octets of the originally-called DTE address is odd, a semi-octet with zeros in bits 4, 3, 2 and 1 is inserted after the last semi-octet in order to maintain octet alignment.

⁴⁾ Applies where the call redirection takes place in a public network.

⁵⁾ This value may be used by some public networks for network-dependent reasons.

⁶⁾ Applies where the call redirection or deflection takes place within a private network so that the private network deflects the call back to the public network that presented the incoming call so that the private network is no longer involved with the call.

⁷⁾ These codes are those set by the DTE or private network in the Call Deflection Selection Facility (see 16.1.4).

⁸⁾ Applies where call redirection or deflection takes place within a private network and the private network deflects the call back to the public network that presented the incoming call so that the private network is no longer involved with the call.

16.1.6 Called line address modified notification facility

The coding of the one-octet Facility Parameter Field is:

<i>Bits</i>	<i>Reason</i>
8 7 6 5 4 3 2 1	
0 0 0 0 0 0 0 1	Call redirection due to originally-called DTE busy ⁹⁾
0 0 0 0 0 1 1 1	Call distribution within a hunt group ⁹⁾
0 0 0 0 1 0 0 1	Call redirection due to originally-called DTE out of order ⁹⁾
0 0 0 0 1 1 1 1	Call redirection due to prior request from originally-called DTE for systematic call redirection ⁹⁾
1 0 0 0 0 0 0 0	Call deflection by the originally-called DTE ¹⁰⁾
1 0 0 0 0 0 0 1	Call redirection due to originally-called DTE busy ¹⁰⁾
1 0 0 0 0 1 1 1	Call distribution within a hunt group ¹⁰⁾
1 0 0 0 1 0 0 1	Call redirection due to originally-called DTE out of order ¹⁰⁾
1 0 0 0 1 1 1 1	Called redirection due to prior request from originally-called DTE for systematic call redirection ¹⁰⁾
1 1 0 0 0 0 0 0	Call deflection by the originally-called DTE ¹¹⁾ or Call deflection by gateway as a result of call deflection by the originally-called DTE ^{11), 12)}
1 1 0 0 0 0 0 1	Call deflection by gateway as a result of call redirection due to originally-called DTE busy ^{11), 12)}
1 1 0 0 1 0 0 1	Call deflection by gateway as a result of call redirection due to originally-called DTE out of order ^{11), 12)}
1 1 0 0 1 1 1 1	Call deflection by gateway as a result of call redirection due to prior request from originally-called DTE for systematic call redirection ^{11), 12)}

NOTE – Bit 8, when received from the DTE and when it is not set to 1, is forced to 1 by the DCE.

⁹⁾ Applies where the call redirection or distribution takes place in a public network.

¹⁰⁾ Applies where the call redirection or distribution takes place within the private network and the private network continues to be involved with the call.

¹¹⁾ These codes are those set by the DTE or private network in the Call Deflection Selection Facility (see 16.1.4).

¹²⁾ Applies where the originally-called DTE is on a private network and the private network deflects the call back to the public network that presented the incoming call so that the private network is no longer involved with the call.

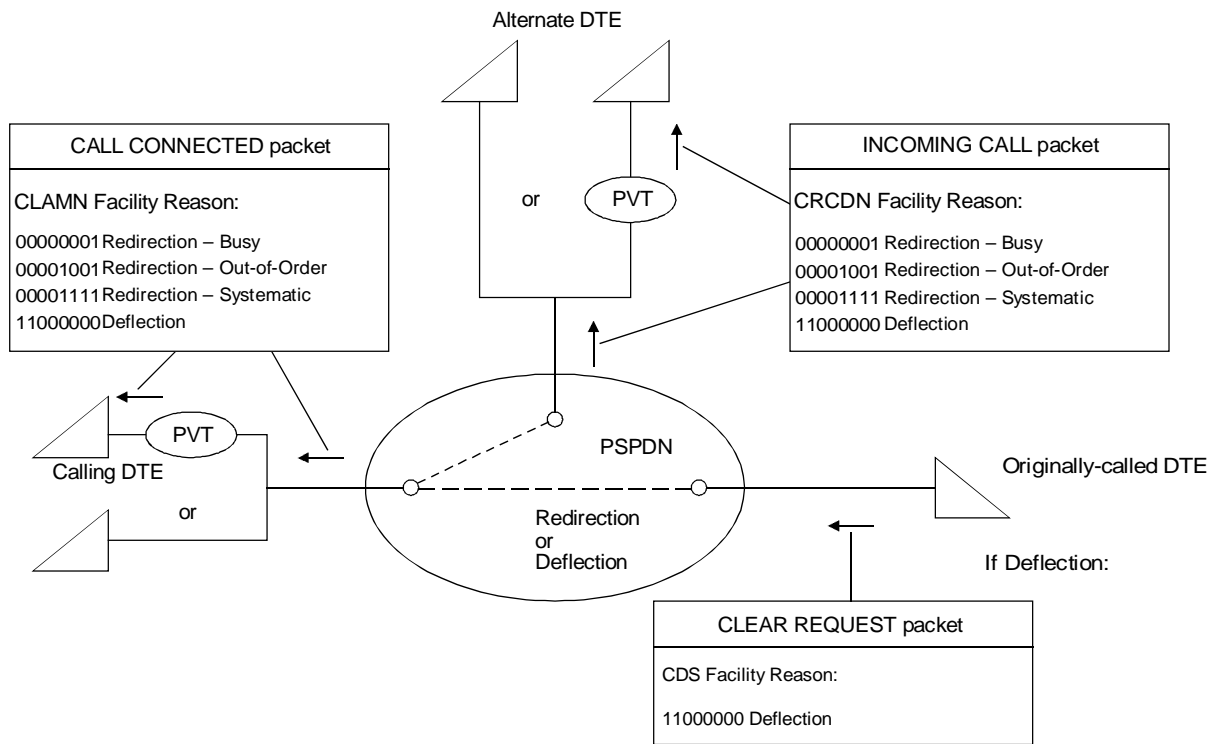

T0718010-93/d01

Call redirection and call deflection operation

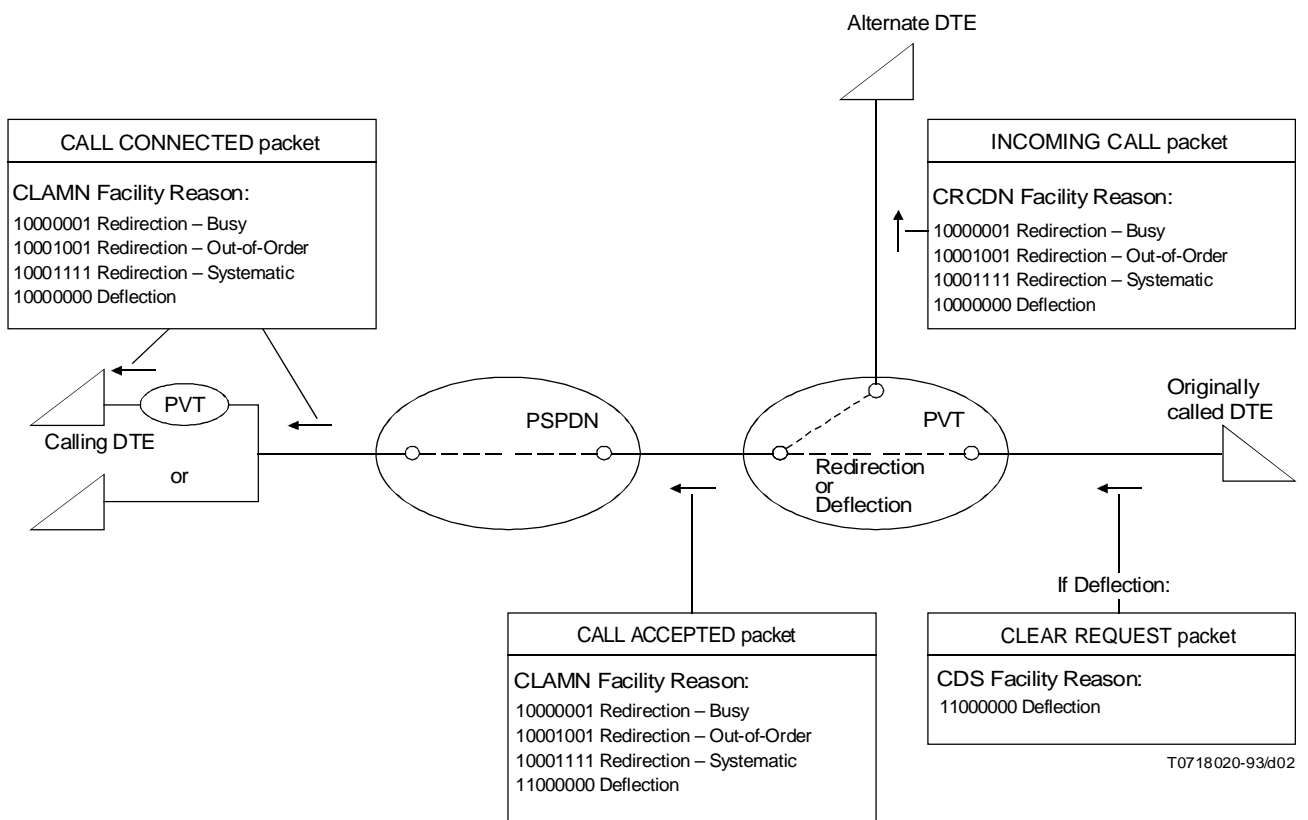
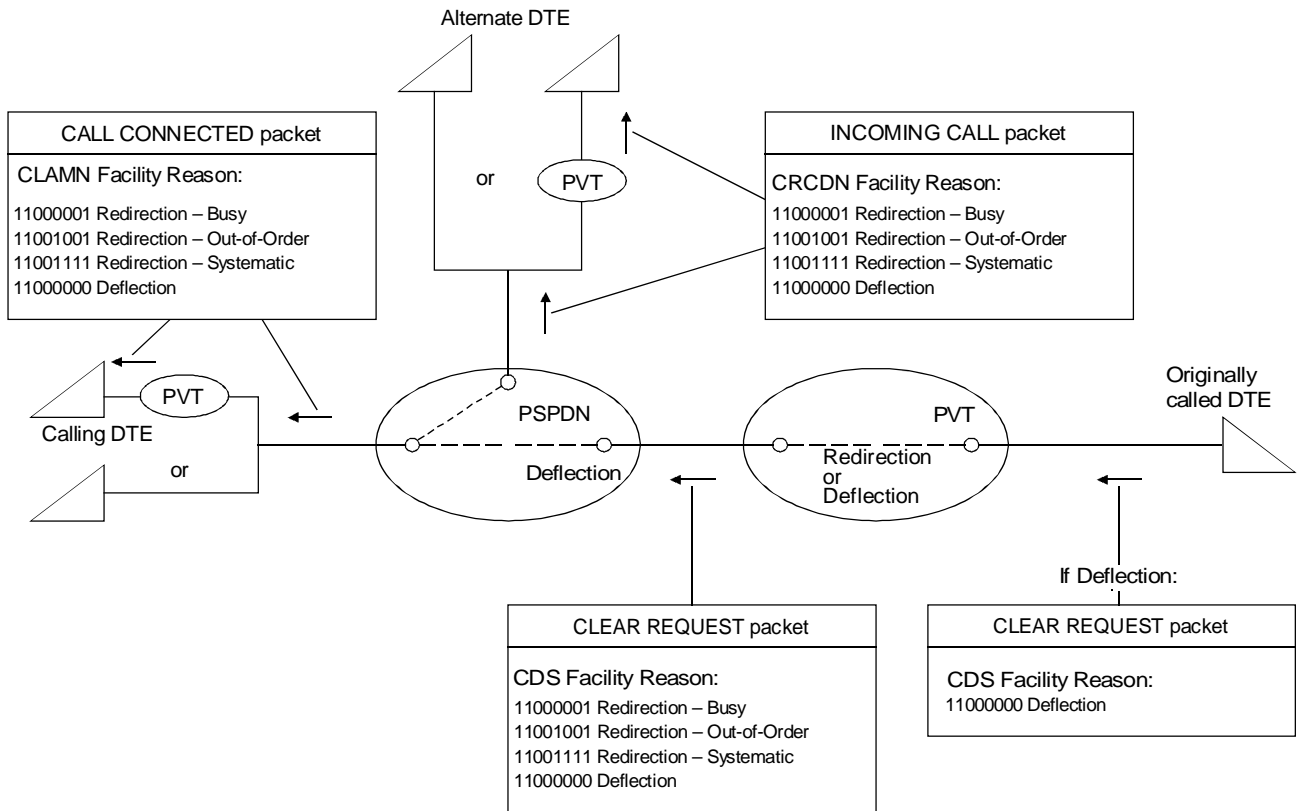

Call redirection and call deflection operation

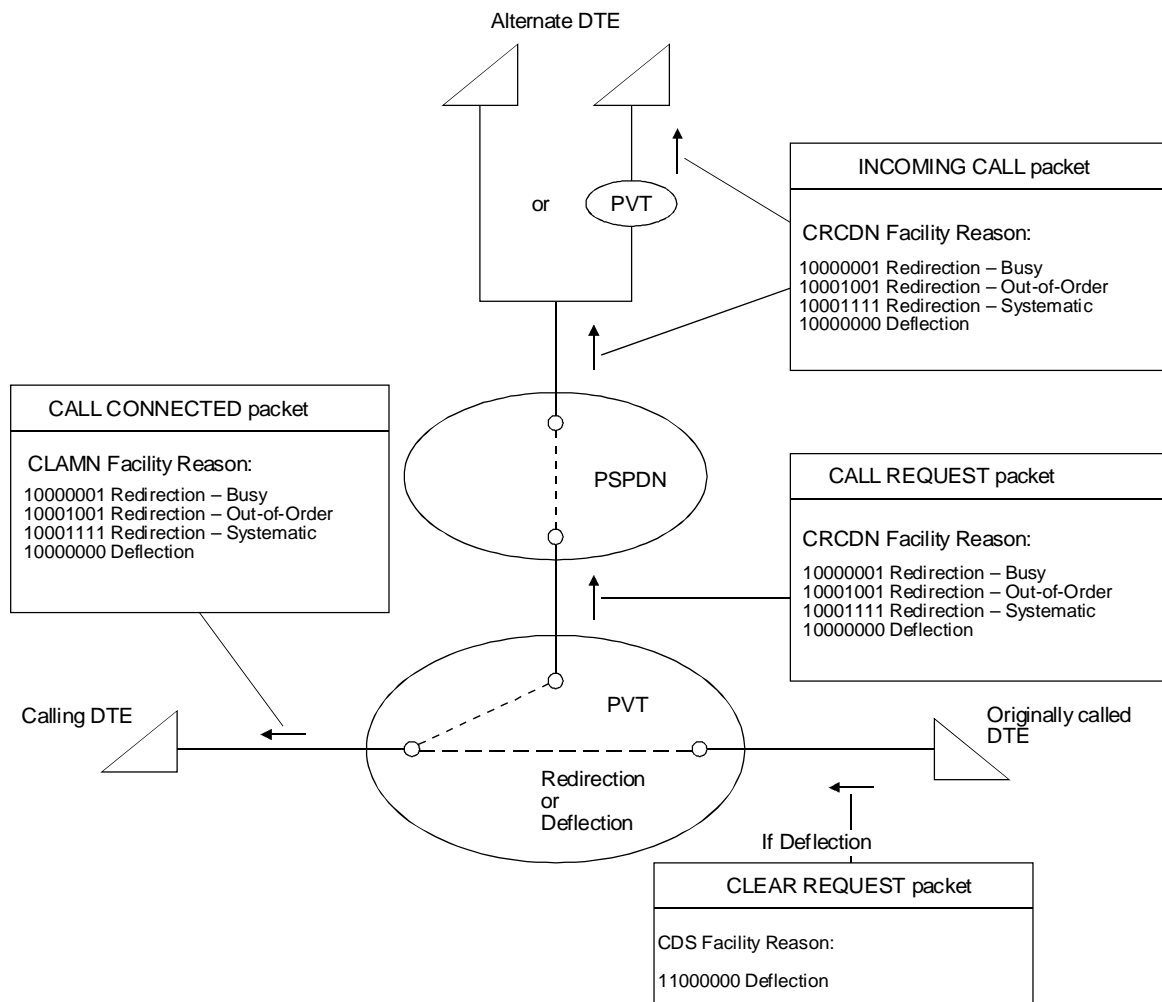

T0718030-93/d03

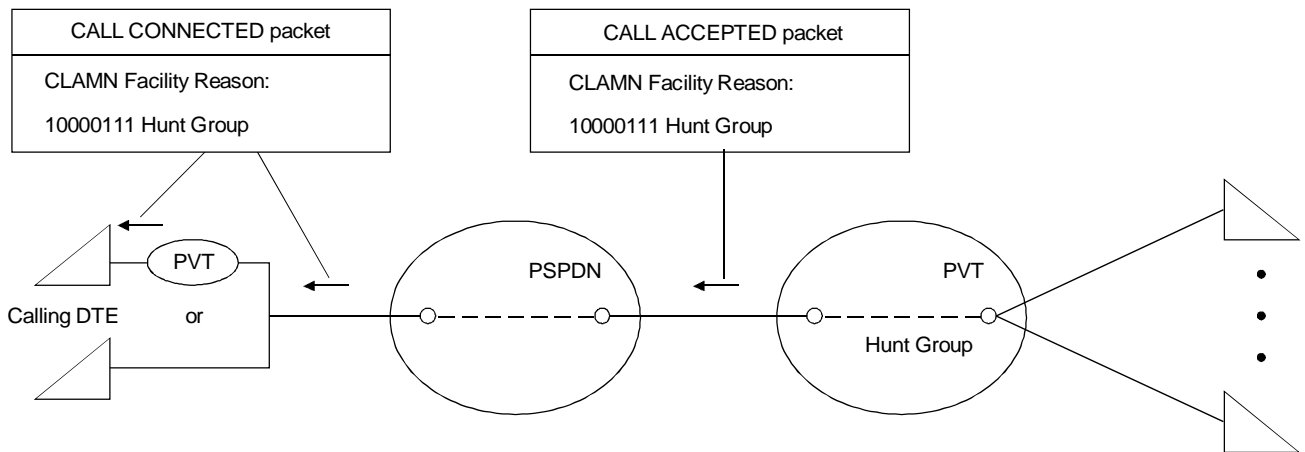
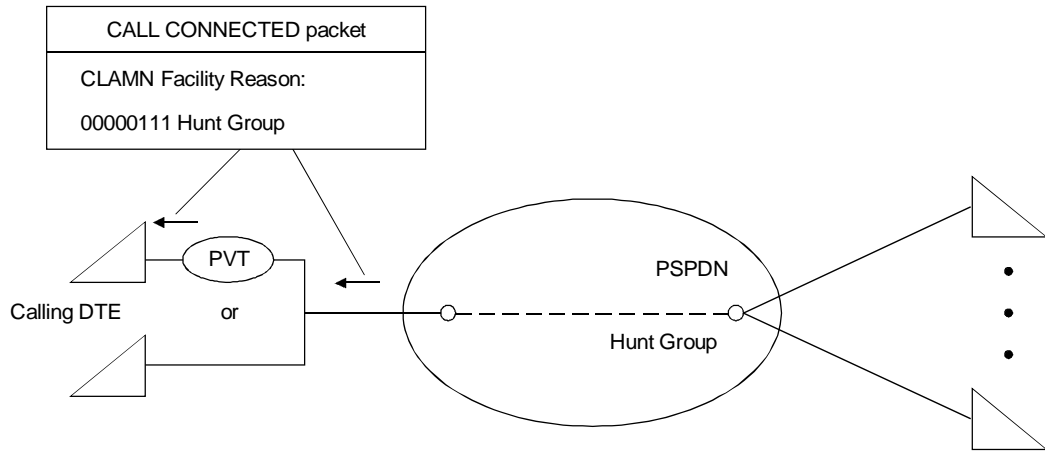

T0718040-93/d04

Hunt group operation

Annex A

Public/Private Network Interworking using Call Control Mapping

(This annex does not form an integral part of this Recommendation)

A.1 Introduction

This annex describes procedures which may be used in certain specific environments to enable Interworking between a public and a private X.25 network. The scope of this annex has been limited to examples of the Call Establishment. Additionally, the examples given are not intended to be all inclusive but rather representative of the more complex cases of interworking.

The signalling of additional information between two networks is essential for data transfer and call release, but have not been covered in this annex.

A.2 Interworking by call control mapping

Interworking by call control mapping for the case in which the interworking function is resident in an interworking unit that is physically separated from the public and private X.25 network is abstractly shown in Figure A.1. Interworking by call control mapping for the case in which the interworking function is resident in the private X.25 networks is abstractly shown in Figure A.3. Interworking by call control mapping for the case in which the interworking function is resident in the public X.25 network is abstractly shown in Figure A.6.

A.3 General principles concerning interworking

This subsection describes some of the general principles that may be used in certain specific environments as a basis for interworking between a public and a private X.25 network.

A.3.1 Call request and call confirmation phases

The establishment of a call between two subscribers consists of two consecutive phases:

- first CALL REQUEST phase, when:
 - a call is requested by a subscriber, with specific parameters;
 - this call request is processed and routed through the networks;
 - the call request is indicated to the called party,
- then a CALL CONFIRMATION phase, when:
 - a call accepted is reported by the called subscriber, unless it does not accept the call;
 - final arrangements are made through the networks for that call;
 - the call establishment is confirmed to the calling subscriber.

A.3.2 Transfer of address information

The interworking arrangements described in this clause provide the capability necessary to transfer all addressing information necessary for the provision of data transmission services between a public and a private X.25 network.

The facility field is present only when a DTE is using an optional user field requiring some indication in the call accepted and call connected packets. Two such facilities that may be present have been specified by ITU-T to support the OSI network service. These facilities are carried after the ITU-T-specified DTE facility marker unchanged between the two packet mode DTEs involved.

In this annex the Calling Address Extension and the Called Address Extension facilities are used as the mechanism to carry the ultimate DTE address for call establishment. Three specific examples have been developed, all of which depend on the occurrence of these facilities to accurately complete the call.

The first of these examples is the case in which the interworking function is resident in a stand alone interworking unit as shown in Figure A.2. In this scenario the following occurs.

A DTE connected to the PSPvtDN populates a Call Request packet with the address that has been assigned to the interworking function (IWF) connected to the PSPvtDN (in this instance IWF1) in the CALLED ADDRESS (CD) field; the PSPvtDN DTE address is placed in the CALLING ADDRESS (CG) field and the CALLED ADDRESS EXTENSION (CDAE) facility is populated with the ultimate DTE address on the PSPDN. The information populated by the DTE is then presented to the IWF by the PSPvtDN in an Incoming Call packet.

Upon receipt of the incoming call packet, the IWF maps the ultimate DTE address contained in the CALLED ADDRESS EXTENSION facility into the CALLED ADDRESS field, it then maps the PSPvtDN address in the CALLING ADDRESS field into the CALLING ADDRESS EXTENSION (CGAE) facility and places the address of IWF connected to the PSPDN (in this instance IWF2) into the CALLING ADDRESS field. Upon the completion of this mapping and address insertion a call request packet is presented to the PSPDN.

Upon receipt of this request the PSPDN presents an incoming call to the DTE, the address information populated in the call request from the IWF. With acceptance of the call by the DTE, a Call Accepted packet is presented to the PSPDN in response to the Incoming Call packet with the same CALLED ADDRESS, CALLING ADDRESS, and CALLING ADDRESS EXTENSION information as presented in the Call Request packet.

Upon receipt of the Call Accepted packet from the DTE, the PSPDN presents to the IWF a Call Connected packet with the same CALLED ADDRESS, CALLING ADDRESS, and CALLING ADDRESS EXTENSION information as presented in the original Call Request to the PSPDN.

Upon receipt of the Call Connected packet from the PSPDN, the IWF maps the PSPvtDN address in the CALLING ADDRESS EXTENSION facility into the CALLING ADDRESS field, it then maps the DTE address contained in the CALLED ADDRESS field into the CALLED ADDRESS EXTENSION facility, and then places the address of the IWF connected to the PSPvtDN into the CALLED ADDRESS field. Upon completion of this mapping and address insertion a Call Accepted packet is presented to the PSPvtDN.

A call flow diagram for the reverse direction has also been included and would adhere to the same principles stated above.

The second example is the case in which the interworking function is resident in the PSPvtDNs that are connected to a PSPDN as shown in Figure A.4. In this scenario the following occurs.

A DTE connected to the PSPvtDN1 populates a Call Request packet with the address that has been assigned to the interworking function resident in the PSPvtDN (in this instance IWF1) in the CALLED ADDRESS field, the PSPvtDN DTE address is placed in the CALLING ADDRESS field and the CALLED ADDRESS EXTENSION facility is populated with the ultimate DTE address on the PSPvtDN2. The information populated by the DTE is then presented to the PSPvtDN in a Call request packet.

Upon receipt of the call request packet, the IWF maps the address of the DTE connected to PSPvtDN1 in the CALLING ADDRESS field into the CALLING ADDRESS EXTENSION facility and places the address of IWF connected to the PSPDN (in this instance IWF2) into the CALLING ADDRESS field. After determining the address of the IWF in PSPvtDN2 based on the address in the CALLED ADDRESS EXTENSION facility the IWF inserts that address in the CALLED ADDRESS field (in this instance IWF3). The address in the CALLED ADDRESS EXTENSION facility is forwarded unchanged. Upon completion of this mapping and address insertion a call request packet is presented to the PSPDN.

Upon receipt of the call request the PSPDN routes the call to the destination PSPvtDN based on the address contained in the CALLED ADDRESS field. All address facilities are passed unchanged to PSPvtDN2 in an Incoming Call packet.

Upon receipt of the Incoming Call packet, the IWF maps the address of the destination DTE connected to PSPvtDN2 in the CALLED ADDRESS EXTENSION facility into the CALLED ADDRESS field and places the address of IWF residing in the PSPvtDN (in this instance IWF4) into the CALLING ADDRESS field. The address in the CALLING ADDRESS EXTENSION facility containing the Address of the originating DTE is forwarded unchanged. Upon completion of this mapping and address insertion an Incoming Call packet is presented to the DTE connected to PSPvtDN2.

The IWF upon receipt of the Call Accepted packet from the DTE constructs and then forwards a Call Accepted packet to the PSPDN with the same CALLED ADDRESS, CALLING ADDRESS, CALLED ADDRESS EXTENSION, and CALLING ADDRESS EXTENSION information as presented in the original Incoming Call packet from the PSPDN for this specific call.

The PSPDN upon receipt of the Call Accepted packet from PSPvtDN2 forwards to PSPvtDN1 a Call Connected packet in which all addresses and address facilities are passed unchanged to PSPvtDN1.

Upon receipt of the Call Connected packet from the PSPDN, the IWF maps the PSPvtDN1 address in the CALLING ADDRESS EXTENSION facility into the CALLING ADDRESS field, and then places the address of the IWF resident in PSPvtDN1 (in this instance IWF1) into the CALLED ADDRESS field. The address contained in the CALLED ADDRESS EXTENSION facility received from the PSPDN is forwarded unchanged. Upon completion of this mapping and address insertion a Call Connected packet is presented to the DTE.

A call flow diagram for the reverse direction has also been included and would adhere to the same principles stated above.

The third and final example is the case in which the interworking function is resident in the PSPDN that connects the PSPvtDNs as shown in Figure A.7. In this scenario the following occurs.

A DTE connected to PSPvtDN1 populates a Call Request packet with the address that has been assigned to the interworking function residing in the PSPDN (in this instance IWF1) in the CALLED ADDRESS field, the PSPvtDN DTE address is placed in the CALLING ADDRESS field and the CALLED ADDRESS EXTENSION facility is populated with the ultimate DTE address on PSPvtDN2. The information populated by the DTE is then presented to the PSPDN by PSPvtDN1 in an Incoming Call packet.

Upon receipt of the Incoming Call packet by the PSPDN, the IWF maps the ultimate DTE address contained in the CALLED ADDRESS EXTENSION facility into the CALLED ADDRESS field into the CALLING ADDRESS EXTENSION facility and places the address of IWF connected to PSPvtDN2 (in this instance IWF2) into the CALLING ADDRESS field. Upon completion of this mapping and address insertion a call request packet is presented to PSPvtDN2.

Upon receipt of the call request the PSPvtDN2 presents an incoming call to the DTE, the address information populated in the call request from the PSPDN. With acceptance of the call by the DTE, a Call Accepted packet is presented to the PSPvtDN2 in response to the Incoming Call Packet with the same CALLED ADDRESS, CALLING ADDRESS and CALLING ADDRESS EXTENSION information as presented in the Call Request packet.

Upon receipt of the Call Accepted packet from the DTE, the PSPvtDN2 presents to the PSPDN a Call Connected packet with the same CALLED ADDRESS, CALLING ADDRESS and CALLING ADDRESS EXTENSION information as presented in the original Call Request to the PSPDN.

Upon receipt of the Call Connected packet from the PSPvtDN2, the IWF maps the PSPvtDN1 address in the CALLING ADDRESS EXTENSION facility into the CALLING ADDRESS field, it then maps the DTE address contained in the CALLED ADDRESS EXTENSION facility, and then places the address of the IWF residing in the PSPDN (in this instance IWF1) into the CALLED ADDRESS field. Upon completion of this mapping and address insertion a Call Accepted packet is presented to the PSPvtDN.

A call flow diagram for the reverse direction has also been included and would adhere to the same principles stated above.

A.4 Additional considerations

As pointed out in the introduction to this annex the examples are not exhaustive but rather representative of some of the cases that might exist. It is intended that based upon a specific network environment that the examples might be implemented as described or as a combination of portions that adhere to the call control mapping at the network interconnection points described herein.

The alteration of addressing information in the provision of other services, i.e. Call redirection/deflection needs urgent further study.

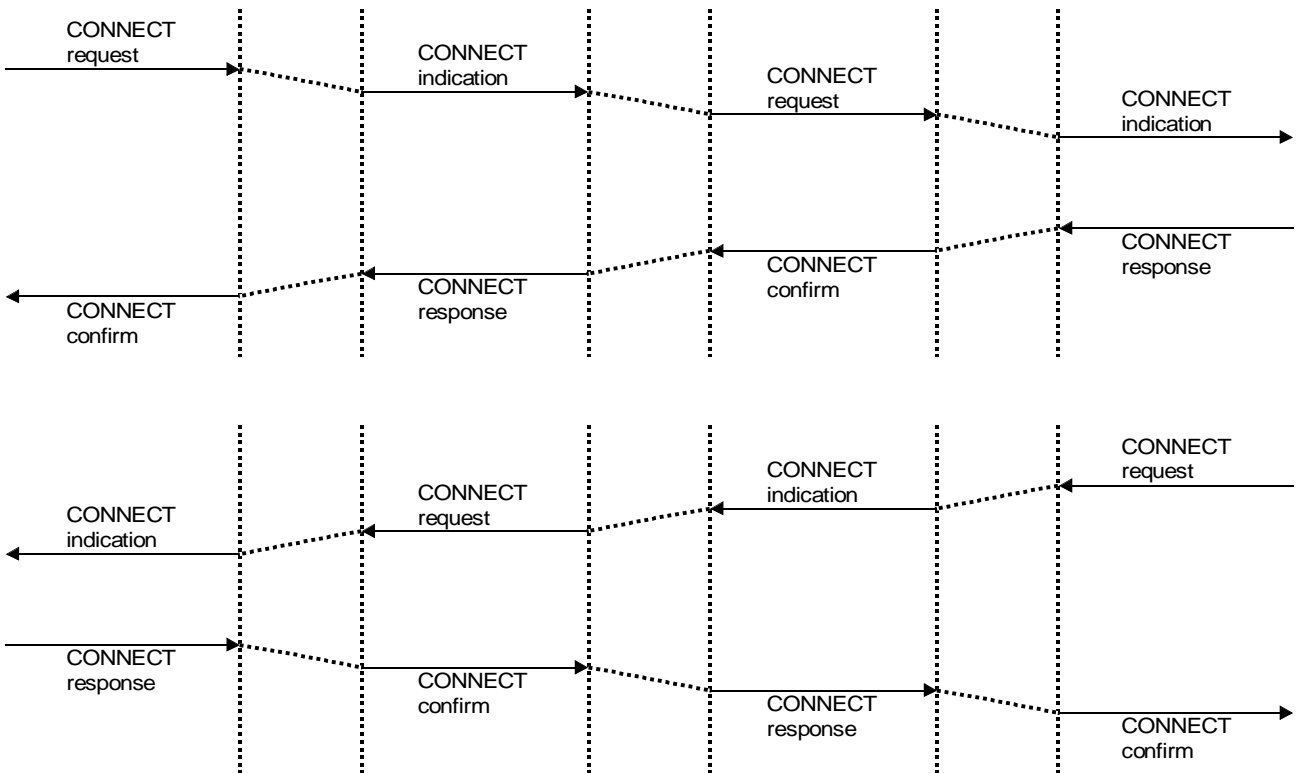
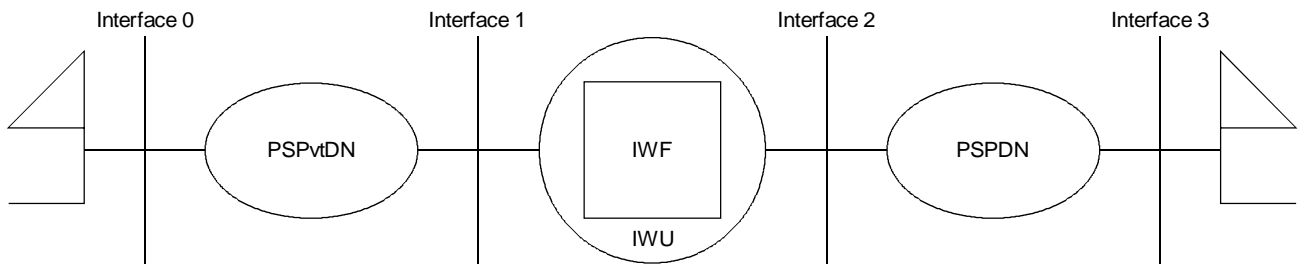

T0714570-93/d12

FIGURE A.1/X.35
Abstract View of Interworking by Call Control Mapping
IWF in an IWU Physically Separated from the PSPvtDN and PSPDN

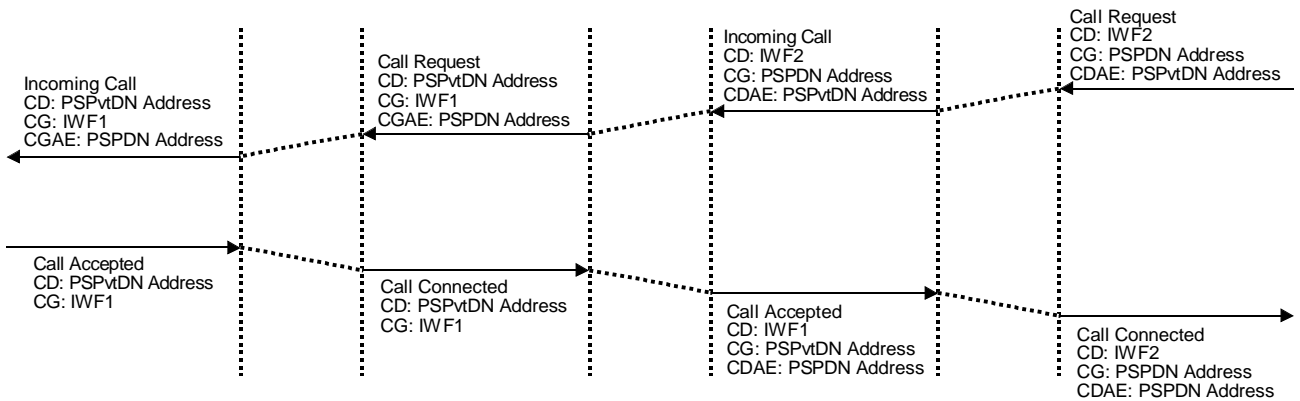
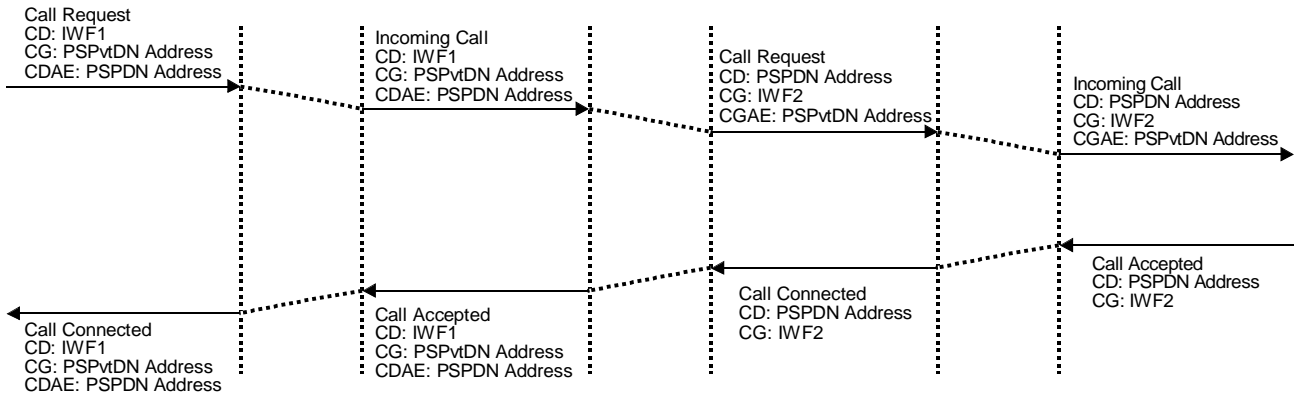
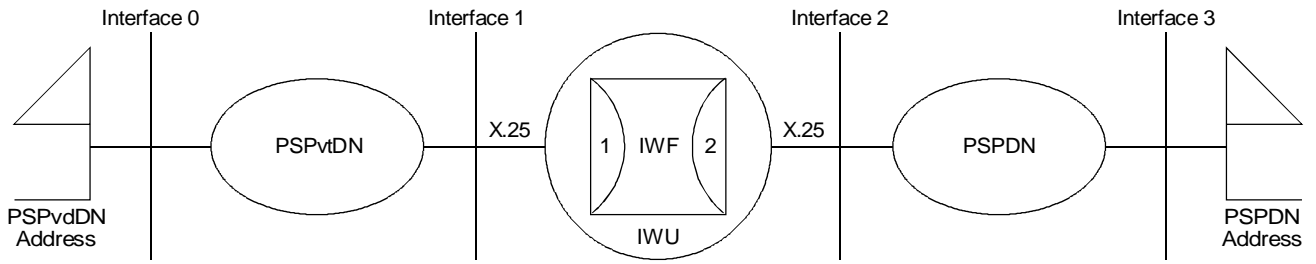

T0714580-93/d13

FIGURE A.2/X.35
Two way mapping
IWF in an IWU physically separated
from the PSPDN and PSPvtDN

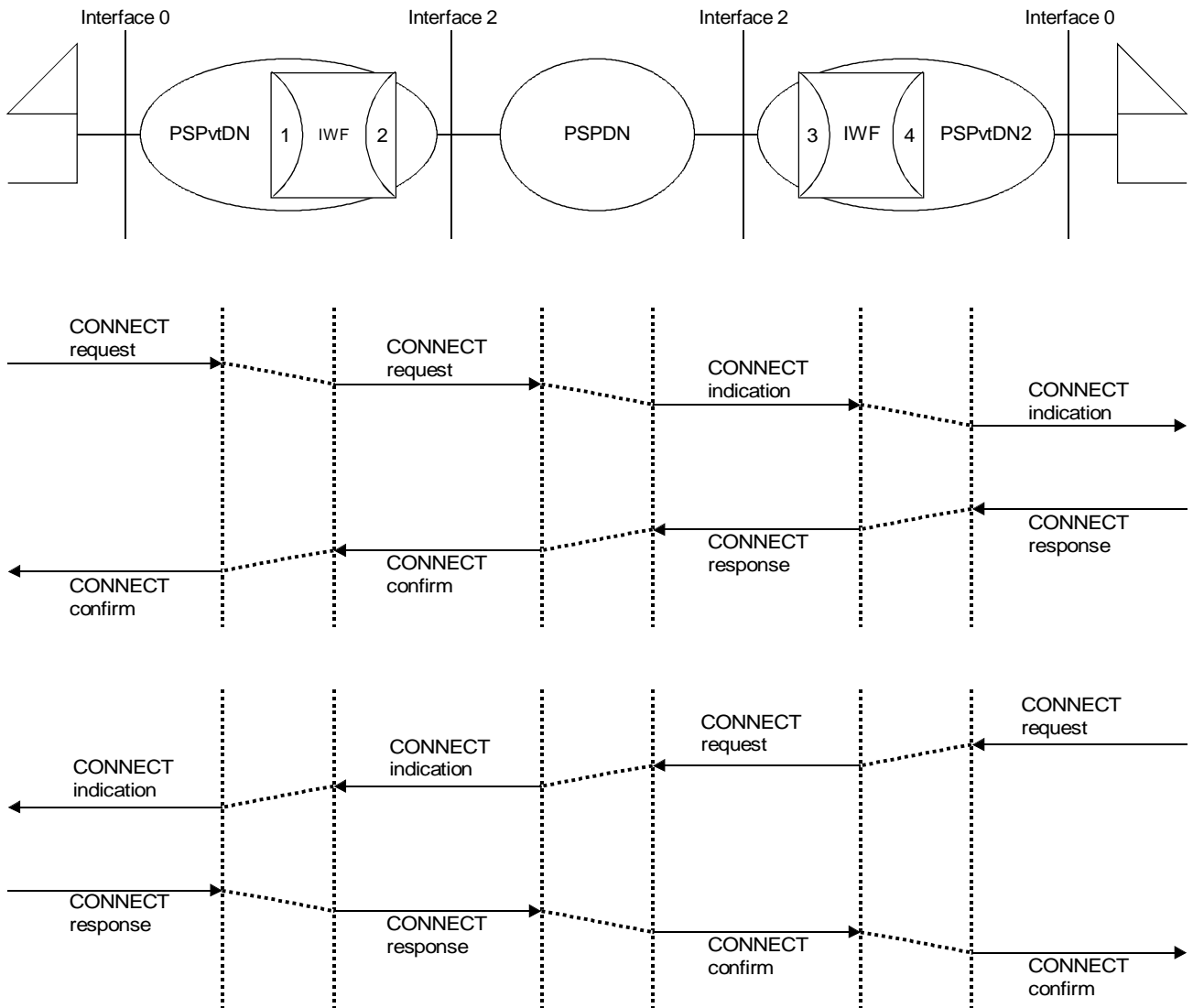

T0714590-93/d14

FIGURE A.3/X.35
Abstract View of Interworking by Call Control Mapping
Two way mapping IWF Embedded in the PSPvtdNs

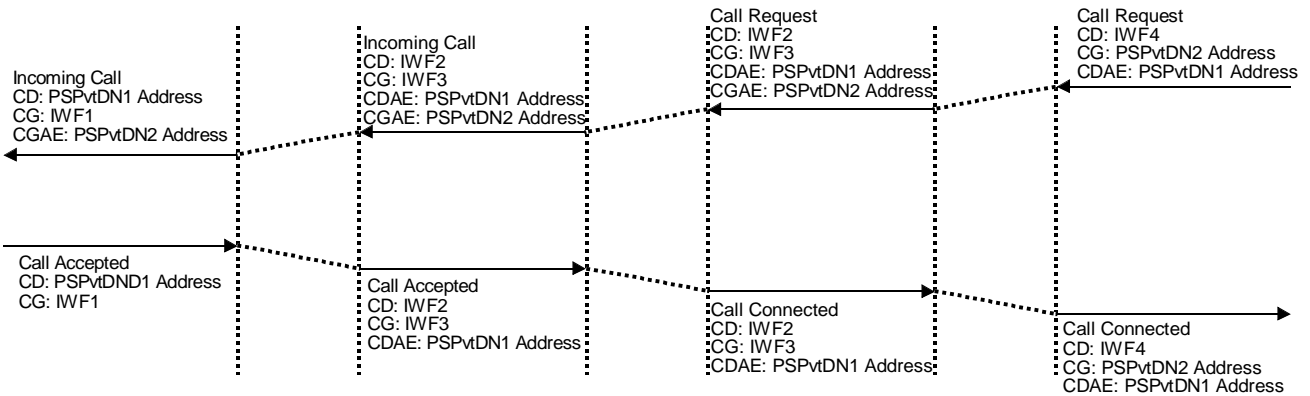
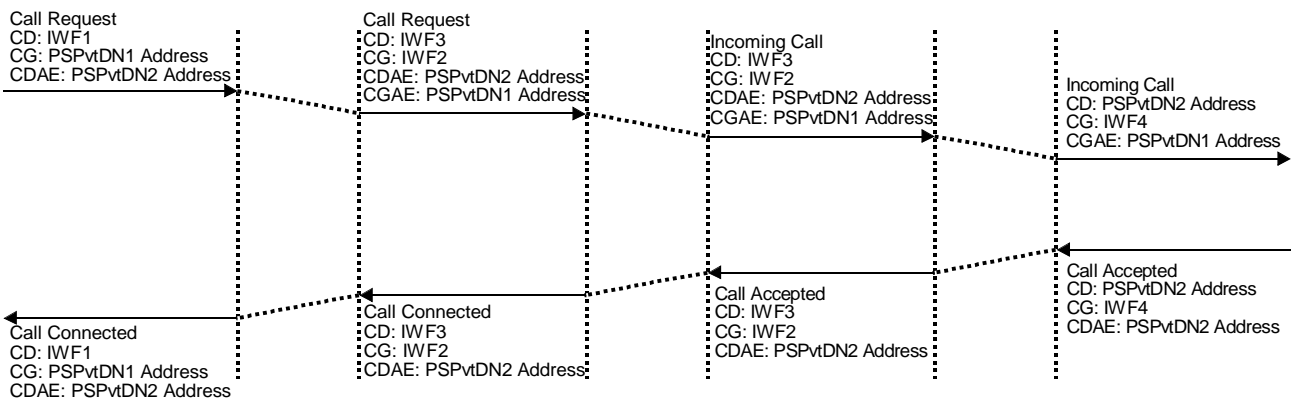
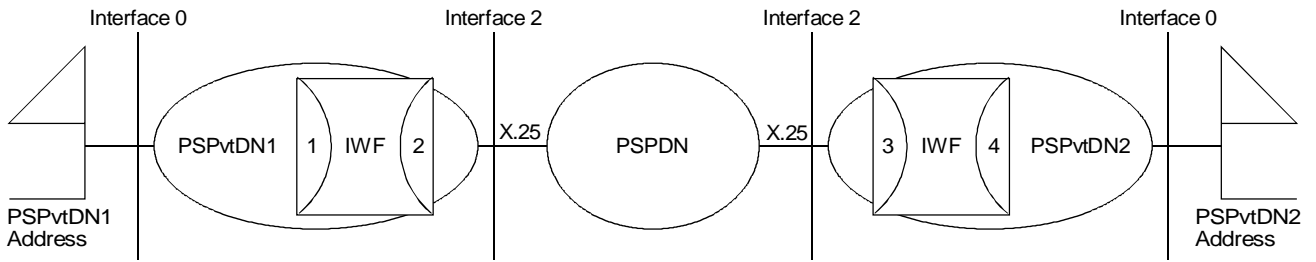

NOTE – IWF1 and IWF4 have a PSPvDN Address – IWF2 and IWF3 have a PSPDN Address.

FIGURE A.4/X.35
Two way mapping
IWF embedded in the PSPvDNs

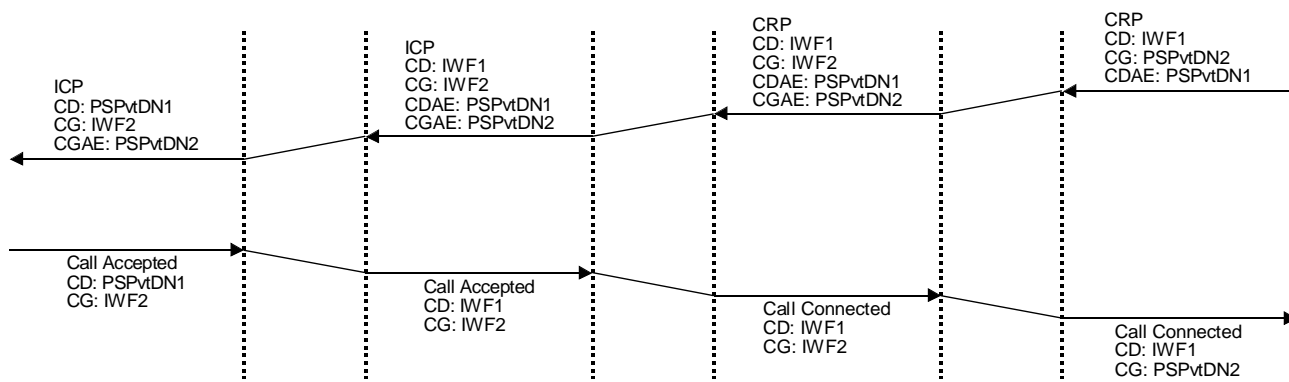
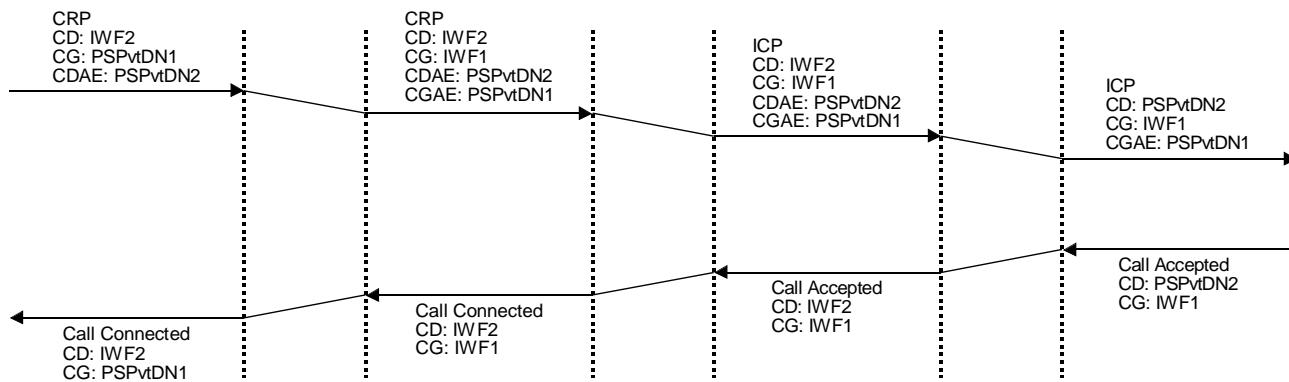
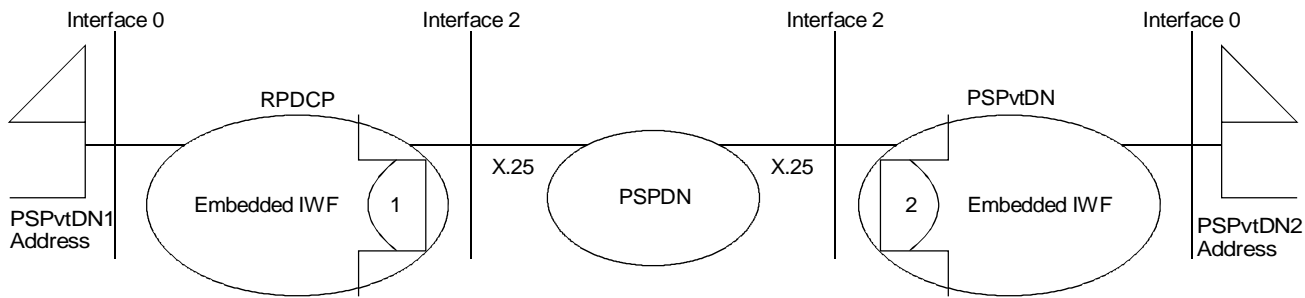

T0714610-93/d16

FIGURE A.5/X.35
IWF embedded in PSPvtdN
Single Interface

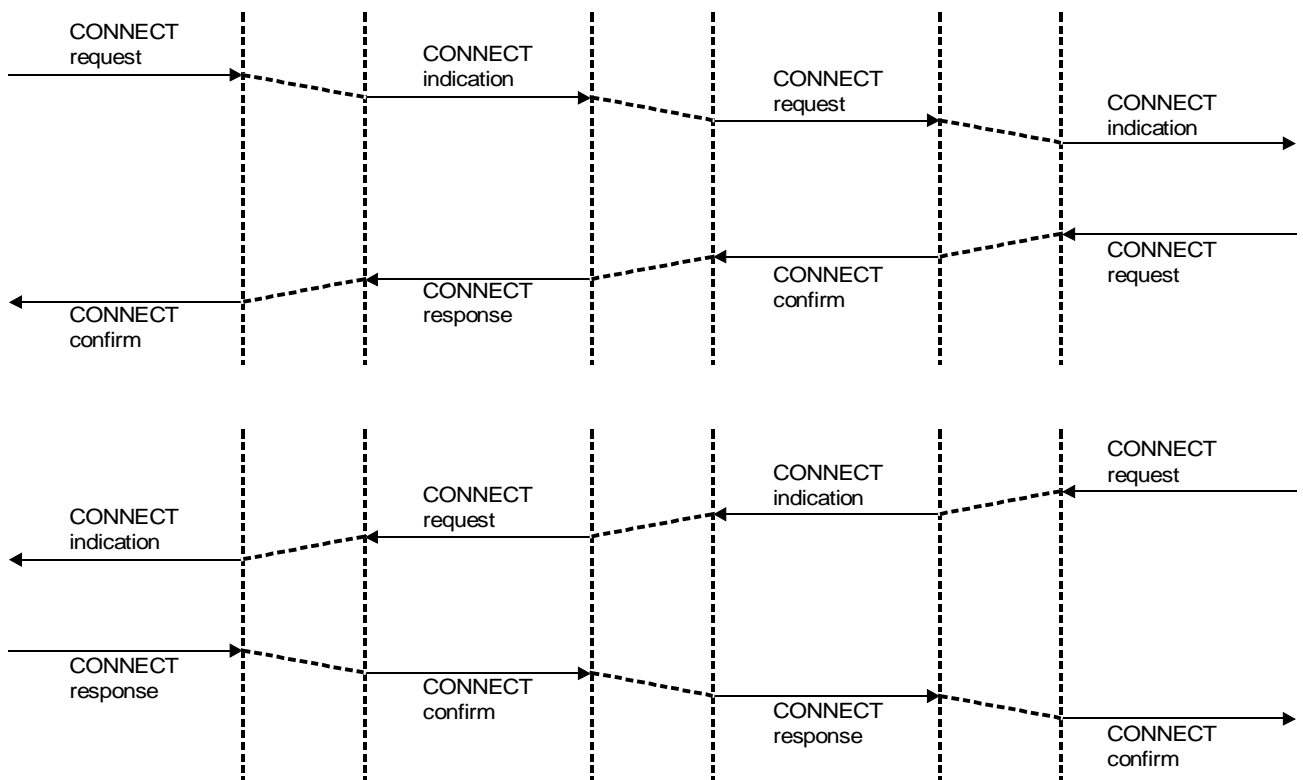
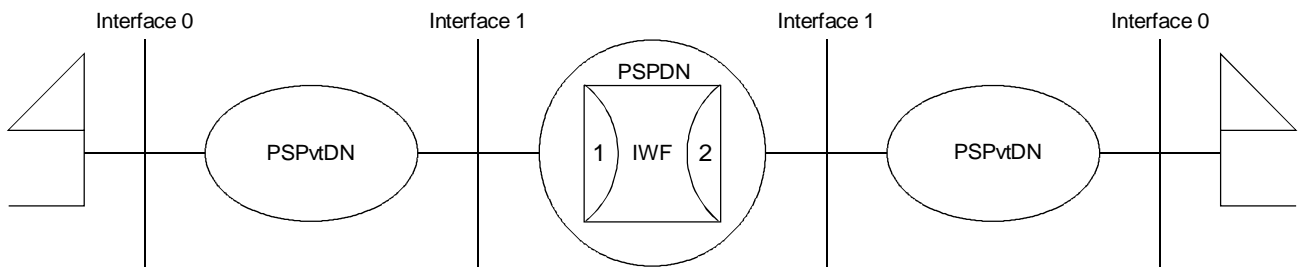

T0714620-93/d17

FIGURE A.6/X.35
Abstract View of Interworking by Call Control Mapping
Two way mapping IWF Embedded in the PSPDN

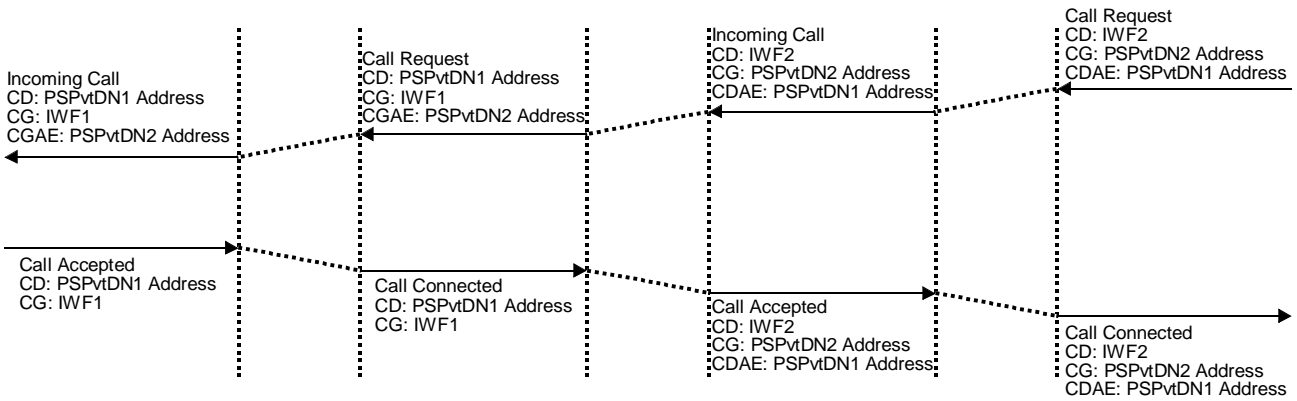
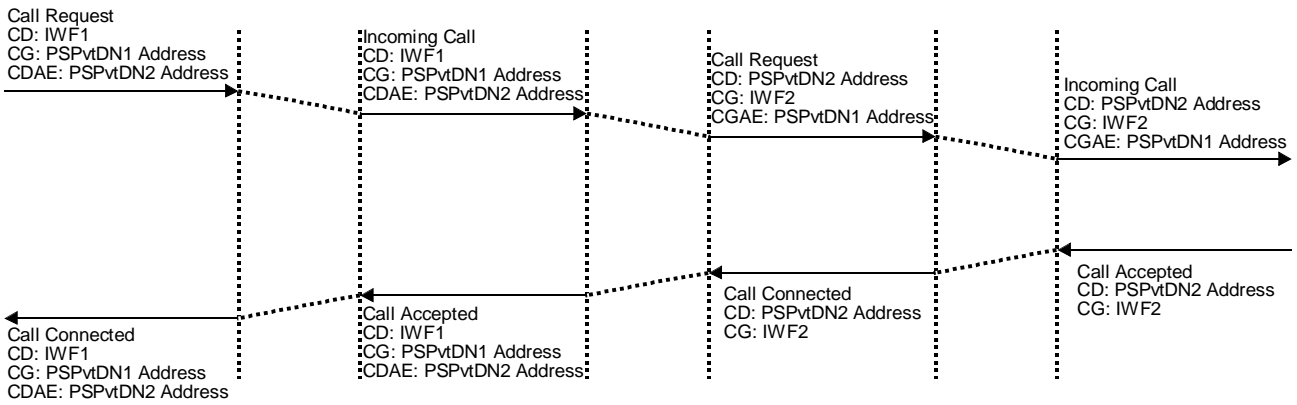
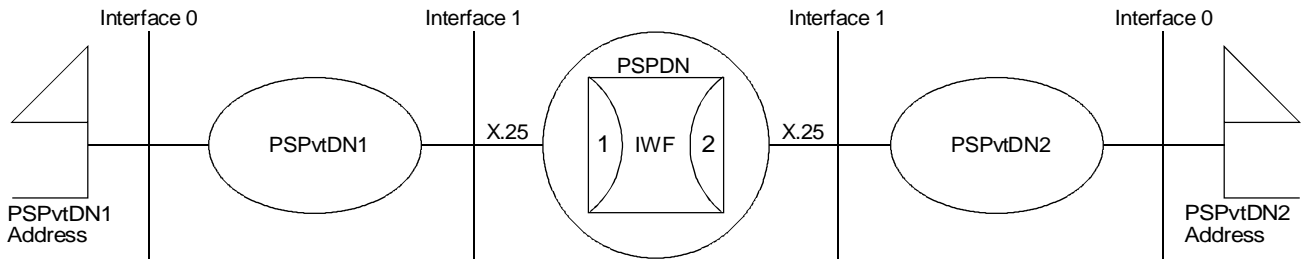

T0714630-93/d18

NOTE – IWF1 and IWF2 have a PSPDN Address.

FIGURE A.7/X.35
Two way mapping
IWF Embedded in the PSPDN

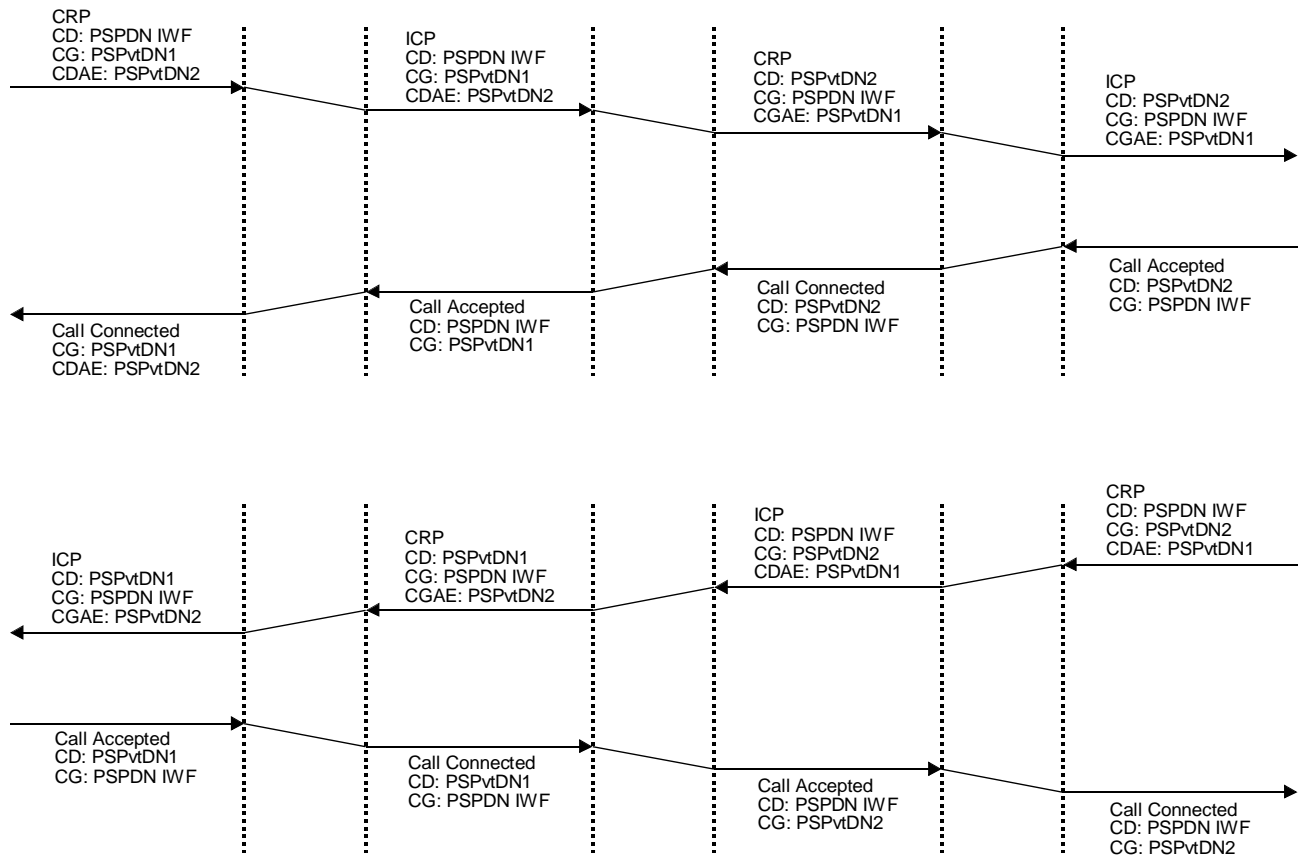
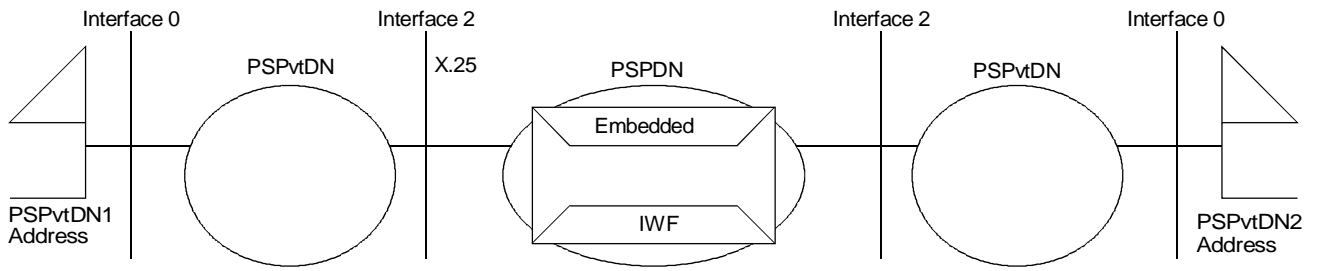

T0714640-93/d19

FIGURE A.8/X.35
IWF Embedded in PSPDN
Single Interface