



INTERNATIONAL TELECOMMUNICATION UNION

ITU-T

TELECOMMUNICATION
STANDARDIZATION SECTOR
OF ITU

X.33

(10/96)

SERIES X: DATA NETWORKS AND OPEN SYSTEM
COMMUNICATION

Public data networks – Interfaces

**Access to packet switched data
transmission services via frame relaying
data transmission services**

ITU-T Recommendation X.33

(Previously "CCITT Recommendation")

ITU-T X-SERIES RECOMMENDATIONS
DATA NETWORKS AND OPEN SYSTEM COMMUNICATION

PUBLIC DATA NETWORKS	X.1-X.199
Services and facilities	X.1-X.19
Interfaces	X.20-X.49
Transmission, signalling and switching	X.50-X.89
Network aspects	X.90-X.149
Maintenance	X.150-X.179
Administrative arrangements	X.180-X.199
OPEN SYSTEM INTERCONNECTION	X.200-X.299
Model and notation	X.200-X.209
Service definitions	X.210-X.219
Connection-mode protocol specifications	X.220-X.229
Connectionless-mode protocol specification	X.230-X.239
PICS proformas	X.240-X.259
Protocol Identification	X.260-X.269
Security Protocols	X.270-X.279
Layer Managed Objects	X.280-X.289
Conformance testing	X.290-X.299
INTERWORKING BETWEEN NETWORKS	X.300-X.399
General	X.300-X.349
Satellite data transmission systems	X.350-X.399
MESSAGE HANDLING SYSTEMS	X.400-X.499
DIRECTORY	X.500-X.599
OSI NETWORKING AND SYSTEM ASPECTS	X.600-X.699
Networking	X.600-X.629
Efficiency	X.630-X.649
Naming, Addressing and Registration	X.650-X.679
Abstract Syntax Notation One (ASN.1)	X.680-X.699
OSI MANAGEMENT	X.700-X.799
Systems Management framework and architecture	X.700-X.709
Management Communication Service and Protocol	X.710-X.719
Structure of Management Information	X.720-X.729
Management functions	X.730-X.799
SECURITY	X.800-X.849
OSI APPLICATIONS	X.850-X.899
Commitment, Concurrency and Recovery	X.850-X.859
Transaction processing	X.860-X.879
Remote operations	X.880-X.899
OPEN DISTRIBUTED PROCESSING	X.900-X.999

For further details, please refer to ITU-T List of Recommendations.

FOREWORD

The ITU-T (Telecommunication Standardization Sector) is a permanent organ of the International Telecommunication Union (ITU). The ITU-T is responsible for studying technical, operating and tariff questions and issuing Recommendations on them with a view to standardizing telecommunications on a worldwide basis.

The World Telecommunication Standardization Conference (WTSC), which meets every four years, establishes the topics for study by the ITU-T Study Groups which, in their turn, produce Recommendations on these topics.

The approval of Recommendations by the Members of the ITU-T is covered by the procedure laid down in WTSC Resolution No. 1 (Helsinki, March 1-12, 1993).

ITU-T Recommendation X.33 was prepared by ITU-T Study Group 7 (1993-1996) and was approved under the WTSC Resolution No. 1 procedure on the 5th of October 1996.

NOTE

In this Recommendation, the expression "Administration" is used for conciseness to indicate both a telecommunication administration and a recognized operating agency.

© ITU 1997

All rights reserved. No part of this publication may be reproduced or utilized in any form or by any means, electronic or mechanical, including photocopying and microfilm, without permission in writing from the ITU.

CONTENTS

	<i>Page</i>
1	Scope and field of operation 1
2	References 1
3	Definitions..... 2
3.1	Frame Relay Service definitions..... 2
3.2	Packet Switched Service definitions..... 3
3.3	Bearer Service definitions..... 3
3.4	ISDN definitions..... 3
3.5	Interworking Definitions 3
4	Abbreviations 3
5	General service aspects 4
6	Reference configurations 5
6.1	Configuration when accessing PSPDN via an FRPDN 5
6.2	Configuration when accessing PSPDN using the ISDN frame relaying services..... 7
6.3	Configuration when Accessing the Packet Switched Data Transmission Services of ISDN via an FRPDN 9
6.4	Configuration when Accessing the Packet Switched Data Transmission Services of ISDN using the ISDN Frame Relaying Services 10
7	Service aspects 10
7.1	Access to PSDTS via an FRPDN 10
7.2	Access to PSDTS using the ISDN Frame Relaying Services 12
8	Addressing and routing aspects..... 14
8.1	Access to PSDTS via an FRPDN 14
8.2	Access to PSDTS using the ISDN Frame Relaying Services 15
9	Interworking with dedicated networks 17
9.1	Access to PSDTS via an FRPDN 17
9.2	Access to PSDTS using the ISDN Frame Relaying services..... 18
10	Procedures 18
10.1	Access to PSDTS via an FRPDN 18
10.2	Access to PSDTS using the ISDN Frame Relaying Services 21
11	Terminal Adaptor functionalities 29
11.1	General..... 29
11.2	Access to PSDTS via an FRPDN 29
11.3	Access to PSDTS using ISDN-FR..... 35

SUMMARY

This Recommendation defines services available and signalling procedures operated at the S/T reference point of an ISDN and at the DTE-DCE interface of an FRPDN for access to packet switched data transmission service via the ISDN-FRBS and the FRPDN.

ACCESS TO PACKET SWITCHED DATA TRANSMISSION SERVICES VIA FRAME RELAY DATA TRANSMISSION SERVICES

(Geneva, 1996)

1 Scope and field of operation

The purpose of this Recommendation is to specify the access to Packet Switched Data Transmission Services (PSDTS) provided by a Packet Switched Public Data Network (PSPDN) or an Integrated Services Digital Network (ISDN) via Frame Relay Data Transmission Services (FRDTS) provided by a Frame Relay Public Data Network (FRPDN) or an ISDN.

2 References

The following Recommendations | International Standards contain provisions which, through reference in this text, constitute provisions of this Recommendation. At the time of publication, the editions indicated were valid. All Recommendations | International Standards are subject to revision; all users of this Recommendation are encouraged to investigate the possibility of applying the most recent editions of the Recommendations | International Standards listed below. A list of the currently valid ITU-T Recommendations is regularly published.

- ITU-T Recommendation X.1 (1996), *International user classes of service in, and categories of access to, public data networks and Integrated Services Digital Networks (ISDNs)*.
- CCITT Recommendation X.21 (1992), *Interface between data terminal equipment and data circuit-terminating equipment for synchronous operation on public data networks*.
- CCITT Recommendation X.21 bis (1988), *Use on public data networks of Data Terminal Equipment (DTE) which is designed for interfacing to synchronous V-Series modems*.
- ITU-T Recommendation X.25 (1996), *Interface between Data Terminal Equipment (DTE) and Data Circuit-Terminating Equipment (DCE) for terminals operating in the packet mode and connected to public data networks by dedicated circuit*.
- ITU-T Recommendation X.30/I.461 (1993), *Support of X.21, X.21 bis and X.20 bis based Data Terminal Equipments (DTEs) by an Integrated Services Digital Network*.
- ITU-T Recommendation X.31/I.462 (1995), *Support of packet mode terminal equipment by an ISDN*.
- ITU-T Recommendation X.32 (1996), *Interface between Data Terminal Equipment (DTE) and Data Circuit-Terminating Equipment (DCE) for terminals operating in the packet mode and accessing a packet switched public data network through a public switched telephone network or an integrated services digital network or a circuit switched public data network*.
- ITU-T Recommendation X.36 (1995)/Amendment 1 (1996), *Interface between Data Terminal Equipment (DTE) and Data Circuit-Terminating Equipment (DCE) for public data networks providing frame relay data transmission service by dedicated circuit – Amendment 1: Switched Virtual Circuit (SVC) signalling and refinements of Permanent Virtual Circuit (PVC) signalling*.
- ITU-T Recommendation X.75 (1996), *Packet-switched signalling system between public networks providing data transmission services*.
- ITU-T Recommendation X.76 (1995) Amendment 1¹⁾, *Network-to-network interface between public data networks providing the frame relay data transmission service*.
- ITU-T Recommendation X.121 (1996), *International numbering plan for public data networks*.

¹⁾ Presently at the stage of draft.

- ITU-T Recommendation X.122/E.166 (1996), *Numbering plan interworking for the E.164 and X.121 numbering plans.*
- ITU-T Recommendation X.213 (1995) | ISO/IEC 8348 (1996), *Information technology – Open Systems Interconnection – Network service definition.*
- ITU-T Recommendation X.300 (1996), *General principles for interworking between public networks and between public networks and other networks for the provision of data transmission services.*
- ITU-T Recommendation X.320 (1996), *General arrangements for interworking between Integrated Services Digital Networks (ISDNS) for the provision of data transmission services.*
- ITU-T Recommendation X.325/I.550 (1996), *General arrangements for interworking between Packet Switched Public Data Networks (PSPDNs) and Integrated Services Digital Networks (ISDNs) for the provision of data transmission services.*
- ITU-T Recommendation X.328 (1996), *General arrangements for interworking between public data networks providing frame relay data transmission services and Integrated Services Digital Networks (ISDN) for the provision of data transmission services.*
- ITU-T Recommendation Q.922 (1992), *ISDN data link layer specification for frame mode bearer services.*
- ITU-T Recommendation Q.931 (1993), *Digital Subscriber Signalling System No. 1 (DSS1) – ISDN user-network interface layer 3 specification for basic call control.*
- ITU-T Recommendation Q.933 (1993), *Digital Subscriber Signalling System No. 1 (DSS1) – Signalling specification for frame mode basic call control.*
- ITU-T Recommendation I.211 (1993), *B-ISDN service aspects.*
- CCITT Recommendation I.230 (1988), *Definition of bearer service categories.*
- CCITT Recommendation I.233.1 (1991), *ISDN frame relaying bearer service.*
- ITU-T Recommendation I.411 (1993), *ISDN user-network interfaces – Reference configurations.*
- ITU-T Recommendation I.430 (1993), *Basic user-network interface – Layer 1 specification.*
- ITU-T Recommendation I.431 (1993), *Primary rate user-network interface – Layer 1 specification.*
- ITU-T Recommendation I.555 (1993), *Frame relaying bearer service interworking.*
- Recommendations I.600-Series – *Maintenance principles.*
- CCITT Recommendation E.164 (1991), *Numbering plan for the ISDN era.*
- CCITT Recommendation V.25 bis (1988), *Automatic calling and/or answering equipment on the General Switched Telephone Network (GSTN) using the 100-Series interchange circuits.*

3 Definitions

3.1 Frame Relay Service definitions

The following terms are defined in Recommendations X.36 and Q.933:

- Frame Relay Switched Virtual Circuit.
- Permanent Virtual Circuit.

The following terms are defined in Recommendation X.1:

- Frame Relay Data Transmission Services.
- Frame Relay Public Data Network.

3.2 Packet Switched Service definitions

The following terms are defined in Recommendation X.25:

- Permanent Virtual Circuit.
- Virtual Call.

The following terms are defined in Recommendations X.1 and X.300:

- Packet Switched Data Transmission Services.
- Packet Switched Public Data Network.

3.3 Bearer Service definitions

The following terms are defined in Recommendations I.230 and I.233.1:

- Circuit Switched Bearer Service.
- Packet Switched Virtual Circuit Bearer Service.
- Frame Mode Bearer Service.

3.4 ISDN definitions

The following terms are defined in Recommendation I.411:

- R reference Point.
- S/T Reference Point.

3.5 Interworking Definitions

The following terms are defined in Recommendations X.300 and I.555:

- Encapsulation Function.
- Interworking by Call Control Mapping.
- Interworking by Port Access.

4 Abbreviations

For the purposes of this Recommendation, the following abbreviations are used.

AU	Access Unit
BECN	Backward Explicit Congestion Notification
C/R	Command/Response
CSBS	Circuit Switched Bearer Service
DDI	Direct-Dialling-In
DE	Discard Eligibility
DLC	Data Link Connection
DLCI	Data Link Connection Identifier
DNIC	Data Network Identification Code
DTP	Data Transfer Phase
EA	Extension Address
ET	Exchange Termination
FCS	Frame Check Sequence
FECN	Forward Explicit Congestion Notification
FH	Frame Handler

FRBS	Frame Relay Bearer Service
FRDTS	Frame Relay Data Transmission Services
FRPDN	Frame Relay Public Data Network
GSTN	General Switched Telephone Network
HDLC	High Level Data Link Control
IEC	International Electrotechnical Commission
ISDN	Integrated Services Digital Network
ISO	International Organization for Standardization
ITU-T	International Telecommunication Union – Telecommunication Standardization Sector
IWF	InterWorking Function
QOS	Quality of Service
LAPB	Link Access Procedure Balanced
LAPF	Link Access Procedure for Frame Mode Bearer Service
MSN	Multiple Subscriber Number
NSAP	Network Service Access Point
NT	Network Termination
OSI	Open Systems Interconnection
PDN	Public Data Network
PH	Packet Handler
PLP	Packet Layer Procedures
PMBS	Packet Mode Bearer Service
PSDTS	Packet Switched Data Transmission Services
PSPDN	Packet Switched Public Data Network
PVC	Permanent Virtual Circuit
SAPI	Service Access Point Identifier
SVC	Switched Virtual Circuit
TA	Terminal Adaptor
TE	Terminal Equipment

5 General service aspects

Packet Switched Data Transmission Services (PSDTS) are provided by Packet Switched Public Data Networks (PSPDNs) and Integrated Services Digital Networks (ISDNs). These PSDTS may be accessed by users of Frame Relay Public Data Networks (FRPDNs) and/or ISDNs providing Frame Relay Data Transmission Services (FRDTS).

NOTE – In this Recommendation, a Public Data Network (PDN) providing FRDTS will be referred to as FRPDN.

- a) This Recommendation defines the aspects of packet switched data transmission services provided by a PSPDN to the users of FRPDN in accordance with the services defined in Recommendations X.36 and X.1.

- b) This Recommendation defines the aspects of packet switched data transmission services provided by a PSPDN to the users of ISDN providing FRDTS in accordance with the services defined in Recommendations X.36 and X.1.
- c) This Recommendation defines the aspects of packet switched data transmission services provided by an ISDN to the users of FRPDN in accordance with the services defined in Recommendations X.36 and X.1.
- d) This Recommendation defines the aspects of the packet switched data transmission services provided by an ISDN to the users of ISDN providing FRDTS in accordance with the services defined in Recommendation I.233.1.
- e) This Recommendation defines the procedures at the user-network interface of an FRPDN to access packet switched data transmission services provided by PSPDN or ISDN in alignment with Recommendation X.36.
- f) This Recommendation defines the procedures at the user-network interface of an ISDN providing FRDTS to access packet switched data transmission services provided by PSPDN or ISDN in alignment with Recommendations I.430, I.431, Q.922 and Q.933.
- g) This Recommendation defines the Terminal Adaptation functions to adapt existing X.25 terminals for use at the user-network interface of an FRPDN in order to access packet switched data transmission services provided by PSPDN or ISDN.
- h) This Recommendation defines the Terminal Adaptation functions to adapt existing X.25 terminals for use at the user-network interface of an ISDN providing FRDTS in order to access packet switched data transmission services provided by PSPDN or ISDN.

6 Reference configurations

There are four reference configurations:

- 1) Access to the Packet Switched Data Transmission Service (PSDTS) provided by a Packet Switched Public Data Network (PSPDN) using the Frame Relay Data Transmission Services (FRDTSs) provided by a Frame Relay Public Data Network (FRPDNs).
- 2) Access to the PSDTS provided by a PSPDN using the FRDTS provided by an Integrated Services Digital Network (ISDN).
- 3) Access to the PSDTS provided by an ISDN using the FRDTS provided by a FRPDN.
- 4) Access to the PSDTS provided by an ISDN using the FRDTS provided by an ISDN.

In the configurations given below, a Terminal Equipment (TE) with X.25 Packet Layer Procedures (PLP) and Frame Relay capabilities is equivalent to a combination consisting of an X.25 Data terminal equipment (DTE) and a Terminal Adaptor (TA) with Frame Relay capabilities.

NOTE – Frame Relay capabilities are in accordance with Recommendation X.36 for TEs/TAs attached to an FRPDN and in accordance with Recommendation I.233.1 for TEs/TAs attached to an ISDN.

In this Recommendation, every reference to the combination of an X.25 DTE and its TA should always be considered as being applicable to a TE with X.25 PLP and Frame Relay capabilities.

6.1 Configuration when accessing PSPDN via an FRPDN

This configuration (Figure 6-1) refers to the case where the PSDTS provided by a PSPDN is accessed using the FRDTS provided by an FRPDN. In this case, a TE/X.25 DTE+TA accesses the PSDTS of the PSPDN by means of a Frame Relay virtual circuit established through the FRPDN. The Frame Relay virtual circuit is routed, within the FRPDN, to an access port of the PSPDN referred to as “Access Unit (AU)”.

A Frame Relay virtual circuit is set up to/from an AU port. An AU supports the possible path setting-up functions for Layer 1 and possible rate adaptation between the PSPDN and the FRPDN. An AU also supports the necessary processing functions for Frame Relay virtual circuits and X.25 virtual circuits.

NOTE 1 – The PSDTS and FRDTS may be provided by the same physical Public Data Network (PDN).

It is important to note that the procedures for accessing PSDTS through an FRPDN user-network interface are independent of where the service provider chooses to locate the AU function. The AU function, logically belonging to the PSPDN, may be physically located either in the PSPDN or in the FRPDN. In case the AU is physically located in the FRPDN, the interface between the PSPDN and the FRPDN is an X.75 interface or a functionally equivalent internal network protocol. In case the AU is physically located in the PSPDN, the interface between the PSPDN and the FRPDN is an X.76 interface or a functionally equivalent internal network protocol. See Recommendation X.300.

The physical interface between a TE/X.25 DTE+TA and a Frame Handler (FH) function in the FRPDN is a direct (i.e. non-switched) access connection as specified in Recommendation X.36. Over that physical interface, Frame Relay Permanent Virtual Circuits (PVCs) and/or Frame Relay Switched Virtual Circuits (SVCs) may be established between the TE/X.25 DTE+TA and the AU.

The procedures used to establish and disconnect Frame Relay PVCs are beyond the scope of this Recommendation (e.g. administrative, management procedures). The procedures for Frame Relay PVC management are specified in Recommendation X.36.

Over the Frame Relay PVC, X.25 virtual circuits (X.25 PVCs and/or X.25 virtual calls) may be established between the TE/X.25 DTE+TA and a remote DTE supported by the PSPDN. More than one X.25 virtual circuit may be established over the Frame Relay PVC.

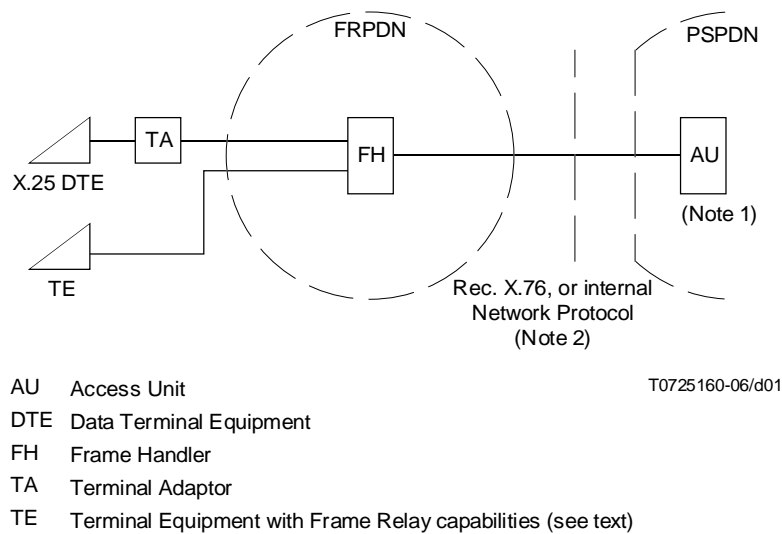

NOTES

- 1 The AU logically belongs to the PSPDN.
- 2 For international interworking, internal network protocols may not apply.

FIGURE 6-1/X.33

Reference configuration for access to PSDTS in PSPDN using FRDTS of FRPDN

The procedures used to establish and disconnect Frame Relay SVCs are categorized according to two cases:

- *Interworking By Port Access* (see Recommendation X.300)

The establishment of a call between a TE/X.25 DTE+TA and a remote DTE is based on a two-step approach. In the first step, a Frame Relay SVC is established between the TE/TA and the AU using X.36 procedures prior to starting X.25 PLP. For an outgoing call from a TE/X.25 DTE+TA, the address of

the AU is contained in the X.36 SETUP message. For an incoming call to a TE/X.25 DTE+TA, the AU is able to set up a Frame Relay SVC through the FRPDN. In the second step, X.25 virtual calls are established between the TE/X.25 DTE and the remote DTE. More than one X.25 virtual call may be established over the Frame Relay switched virtual call.

NOTE 2 – No. X.25 PVCs are established over a Frame Relay SVC.

For an outgoing call from a TE/X.25 DTE+TA, the address of the remote called DTE is contained in the called address field of the X.25 incoming *call packet*. For an incoming call to a TE/X.25 DTE+TA, the address of the TE/X.25 DTE+TA is contained in the called address field of the X.25 *call request packet*. The AU acts as a relay for X.25 PLP information flows.

The detailed procedures are specified in clause 10.

– *Interworking By Call Control Mapping* (see Recommendation X.300)

In this interworking scenario, the AU also provides an InterWorking Function (IWF) (referred to as AU/IWF, in this case). The AU/IWF consists of an FH function, a Packet Handler (PH) function and the necessary functions to interwork them. The interworking component of the AU/IWF performs the mapping between the corresponding protocol procedures at the interfaces on its two sides.

The establishment of a call between a TE/X.25 DTE+TA and a remote DTE is based on a single step approach. For an outgoing call, the TE/X.25 DTE+TA establishes a Frame Relay SVC across the FRPDN to the called DTE using X.36 procedures. The address of the called DTE is contained in the X.36 SETUP message. The Frame Relay SVC is routed by the FRPDN to the AU/IWF of the PSPDN. The AU/IWF completes the call to the remote called DTE as an X.25 virtual call. For an incoming call, the remote calling DTE establishes an X.25 virtual call across the PSPDN to the called TE/X.25 DTE+TA using X.25 procedures. The address of the called TE/X.25 DTE+TA is contained in the called address field of the X.25 call request packet. The X.25 virtual call is routed by the PSPDN to the AU/IWF. The AU/IWF completes the call to the called TE/X.25 DTE+TA as a Frame Relay SVC through the FRPDN. The AU/IWF performs the mapping between the X.36 call control procedures and X.25 Call Setup and Call Clearing procedures. For data transfer, the AU acts as a relay for X.25 Data Transfer Phase (DTP) information flows. A single virtual call is established over the Frame Relay SVC.

The detailed procedures for the case of interworking by call control mapping are for further study.

6.2 Configuration when accessing PSPDN using the ISDN frame relaying services

This configuration (Figure 6-2) refers to the case where the PSDTS provided by a PSPDN is accessed using the FRBS provided by an ISDN. In this case, a TE/X.25 DTE+TA accesses the PSDTS of the PSPDN by means of a Frame Relay virtual circuit established through the ISDN. The Frame Relay virtual circuit is routed, within the ISDN, to an AU port of the PSPDN.

A TE/X.25 DTE+TA accesses the FRDTS of the ISDN by establishing a Frame Relay access connection to an FH function in the ISDN. The ISDN FH function provides the frame relaying service by supporting the core aspects of Recommendation Q.922 specified in Annex A/Q.922. The Frame Relay connection is then routed from the ISDN FH function to the AU port of the PSPDN, possibly via other FHs.

The service provider may choose to locate the Frame Relay handling functions either:

- a) in the ISDN local exchange; or
- b) in a remote exchange.

A physical access connection must be established between a TE/X.25 DTE+TA and an FH function in the ISDN by procedures beyond the scope of this Recommendation before the Frame Relay virtual circuit procedures specified in this Recommendation can be used. If the FH is located in a remote exchange, a circuit switched connection needs to be first

established between the TE/X.25 DTE+TA and the FH. In this case, B- and H-channels can be used at the (ISDN) user-network interface. In case the FH is located in the local ISDN exchange, B-, D- and H-channels can be used at the user-network interface.

It is important to note that the procedures for accessing PSDTS through an FH in the ISDN are independent of where the ISDN service provider chooses to locate the FH (i.e. in the local exchange, a remote exchange, or a Frame Relaying module in the PSPDN). It is also important to note that the procedures at the ISDN user-network interface to access PSDTS of the PSPDN are independent of where the service provider chooses to locate the AU function. The AU function, logically belonging to the PSPDN, may be physically located either in the PSPDN or in the ISDN. In case the AU is physically located in the ISDN, the interface between the PSPDN and the ISDN is an X.75 interface or a functionally equivalent internal network protocol. In case the AU is physically located in the PSPDN, the interface between the PSPDN and the ISDN is a Q.933 (if permanent)/X.76 (if switched) interface or a functionally equivalent internal network protocol. See Recommendations X.300 and X.325.

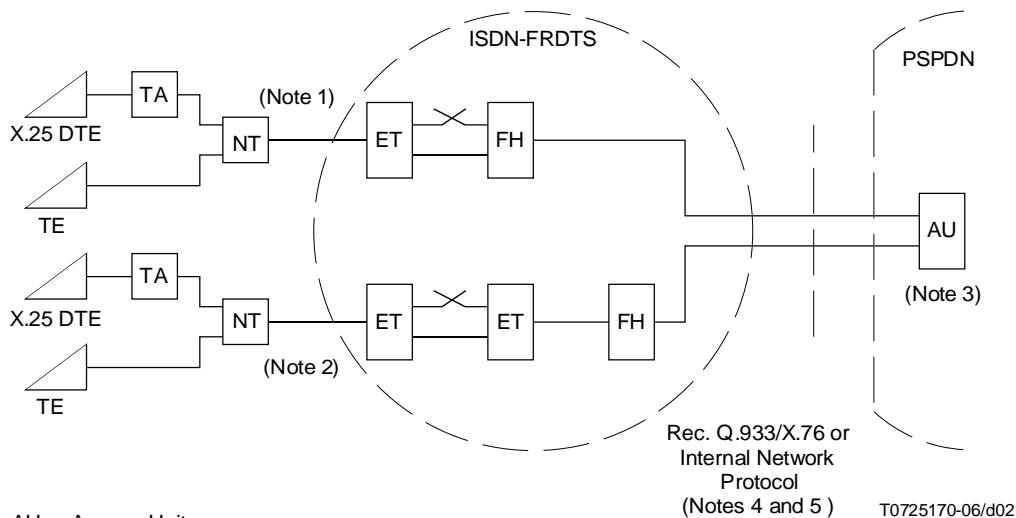

- AU Access Unit
- DTE Data Terminal Equipment
- ET Exchange Termination
- FH Frame Handler
- NT Network Termination 2 and/or 1
- TA Terminal Adaptor
- TE Terminal Equipment with Frame Relay capabilities (see text)

NOTES

- 1 B-, D-, and H-channels can be used.
- 2 B- and H-channels can be used.
- 3 The AU logically belongs to the PSPDN.
- 4 For international interworking, internal network protocols may not apply.
- 5 Recommendation Q.933 applies if permanent and Recommendation X.76 applies if switched.

FIGURE 6-2/X.33

Reference configuration for access to PSDTS in PSPDN using FRDTS of ISDN

The provision of the physical access connection from a TE/X.25 DTE+TA to the FH function is either on a semi-permanent basis or on a demand basis. If provisioned on a semi-permanent basis, Frame Relay PVCs and/or Frame Relay SVCs can be established. If provisioned on a demand basis, only Frame Relay SVCs can be established. Frame Relay PVCs are not allowed.

NOTE 1 – In Recommendation X.31, X.25 PVCs are not supported over a demand access connection. See clause 6/X.31.

For the establishment and disconnection of Frame Relay PVCs, the considerations specified in 6.1 above apply.

For the establishment and disconnection of Frame Relay SVCs, the considerations specified in 6.1 above apply by replacing “X.36” with “Q.933” and replacing “FRPDN” with “ISDN”.

NOTE 2 – As mentioned in 6.1, the detailed procedures for the case of interworking by call control mapping are for further study.

6.3 Configuration when Accessing the Packet Switched Data Transmission Services of ISDN via an FRPDN

This configuration (Figure 6-3) refers to the case where the packet switched data transmission services of the ISDN are accessed using the FRDTS provided by an FRPDN. In this case, a TE/X.25 DTE+TA uses a Frame Relay virtual circuit established through the FRPDN to access a PH function within the ISDN via an Access Unit (AU). The AU may be accessed in various ways depending on the related ISDN implementation alternatives (see Figure 6-3). In any case, a Frame Relay virtual circuit through the FRPDN is set up to/from an AU port which supports the possible path setting-up functions for Layer 1 and possible rate adaptation between the FRPDN and the ISDN. The PH part of the AU function supports the necessary processing functions for Frame Relay virtual circuits and X.25 virtual circuits.

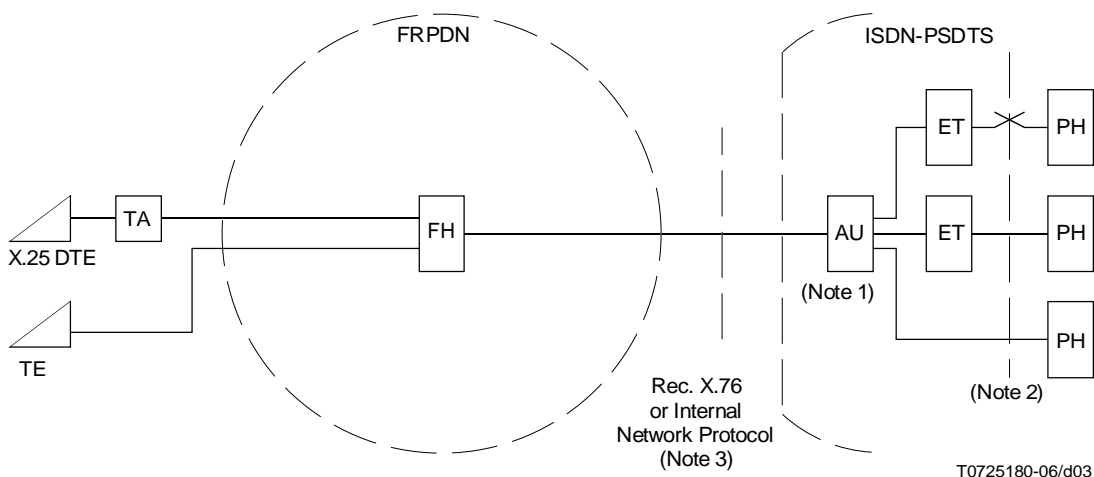

- AU Access Unit
- DTE Data Terminal Equipment
- ET Exchange Termination
- FH Frame Handler
- PH Packet Handler
- TA Terminal Adaptor
- TE Terminal Equipment with Frame Relay capabilities (see text)

NOTES

- 1 The AU logically belongs to the ISDN.
- 2 Examples of arrangements between the AU and PH. Internal procedures between the AU and PH apply with no relevance on the FRPDN use-network interface procedures.
- 3 For international interworking, internal network protocols may not apply.

FIGURE 6-3/X.33

Reference configuration for access to PSDTS in ISDN using FRDTS of FRPDN

It is important to note that the procedures for accessing the ISDN virtual circuit service through an FRPDN user-network interface are independent of where the service provider chooses to locate the AU function. The AU function, logically belonging to the ISDN, may be physically located either in the ISDN or in the FRPDN. In case the AU function is physically located in the FRPDN, the interface between the FRPDN and the ISDN is an X.75 interface or a functionally equivalent internal network protocol. In case the AU function is physically located in the ISDN, the interface between the FRPDN and the ISDN is an X.76 interface or a functionally equivalent internal network protocol. See Recommendations X.300 and X.328.

For the following procedures:

- the establishment and disconnection of Frame Relay PVCs between a TE/X.25 DTE+TA and the ISDN AU function; and
- the establishment and disconnection of Frame Relay SVCs between a TE/X.25 DTE+TA and the ISDN AU function,

the considerations specified in 6.1 above apply.

6.4 Configuration when Accessing the Packet Switched Data Transmission Services of ISDN using the ISDN Frame Relaying Services

This configuration (Figure 6-4) refers to the case where the ISDN packet switched data transmission services of the ISDN are accessed using the ISDN frame relaying service. In this case, a TE/X.25 DTE+TA uses a Frame Relay virtual circuit to access a PH function within the ISDN via an Access Unit (AU).

NOTE – The packet switched data transmission services and frame relaying data transmission services may be provided by the same ISDN.

For the following procedures:

- the prior establishment of a physical access connection between a TE/X.25 DTE+TA and the ISDN FH function;
- the establishment and disconnection of Frame Relay PVCs between a TE/X.25 DTE+TA and the ISDN AU function, and
- the establishment and disconnection of Frame Relay SVCs between a TE/X.25 DTE+TA and the ISDN AU function,

the considerations specified in 6.2 above apply.

7 Service aspects

7.1 Access to PSDTS via an FRPDN

Interworking considerations are defined in clause 9.

7.1.1 Service characteristics

In this case, the FRPDN offers a Frame Relay PVC or SVC between a TE/TA and an AU port. In the Frame Relay SVC case, the AU must be selected by the called party number information element of an X.36 SETUP message used on a signalling Data Link Connection (DLC) identified by DLCI = 0 at the FRPDN user-network interface when the TE/TA sets up the Frame Relay SVC to the AU. In the Frame Relay PVC access case, X.36 signalling protocol messages are not used.

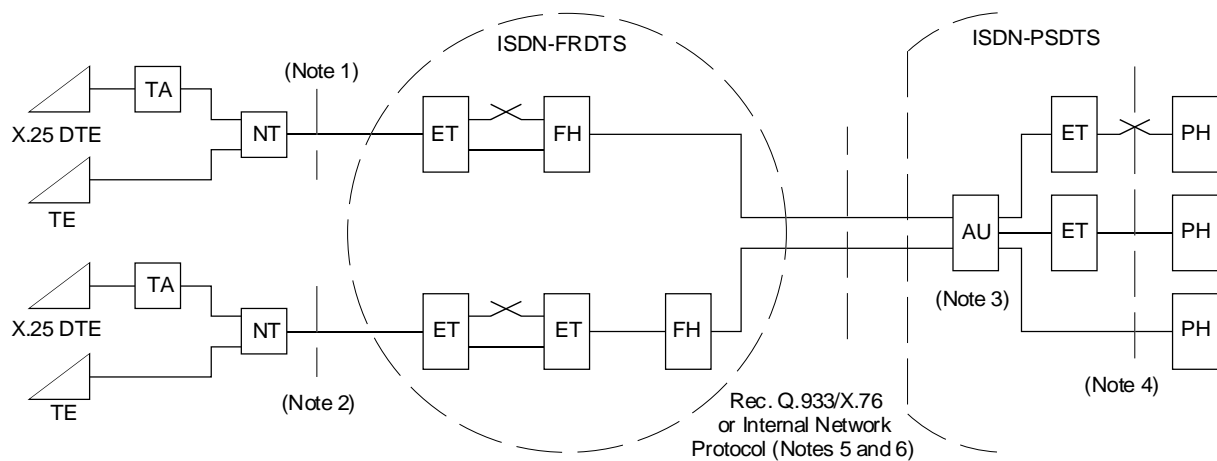

T0725190-06/d04

- AU Access Unit
 DTE Data Terminal Equipment
 ET Exchange Termination
 FH Frame Handler
 NT Network Termination 2 and/or 1
 PH Packet Handler
 TA Terminal Adaptor
 TE Terminal Equipment with Frame Relay capabilities (see text)

NOTES

- 1 B-, D-, and H-channels can be used.
- 2 B- and H-channels can be used.
- 3 The AU logically belongs to the ISDN.
- 4 Examples of arrangements between the AU and PH. Internal procedures between the AU and PH apply with no relevance on the FRPDN user-network interace procedures.
- 5 For international interworking, internal network protocols may not apply.
- 6 Recommendation Q.933 applies if permanent and Recommendation X.76 applies if switched.

FIGURE 6-4/X.33

Reference configuration for access to PSDTS in ISDN using FRDTS of ISDN

A distinction in service characteristics is made between the two methods of interworking (i.e. port access, call control mapping, see Recommendation X.300) that may be used to access PSDTS.

- In the port access method of interworking, there is a requirement for identification of the TE/X.25 DTE+TA to the AU function when the TE/X.25 DTE+TA accesses the AU through the FRPDN or when the TE/X.25 DTE+TA is accessed by the AU through the FRPDN.

The "TE/X.25 DTE+TA identity" is a means of referring to the TE/X.25 DTE+TA. The TE/X.25 DTE+TA identity is either explicitly agreed to between the TE/X.25 DTE+TA and the Administration providing the AU function or is implicitly acceptable to the AU Administration through agreements with other Administrations, organizations or authorities (see Recommendation X.32).

NOTE 1 – The Administration providing the AU function will be referred to as the “AU Administration” in the following discussion.

The characteristics of the service which a TE/X.25 DTE+TA obtains will depend upon whether the AU considers the TE/X.25 DTE+TA identified for each Frame Relay SVC.

Two components are required in order for a TE/X.25 DTE+TA to be considered identified (see Recommendation X.32):

- a) the TE/X.25 DTE+TA is administratively registered either:
 - 1) through direct arrangement with the AU Administration (i.e. explicitly); or
 - 2) through pre-arrangement between the AU Administration and the FRPDN Administration or another authority, and direct arrangement between the TE/X.25 DTE+TA and that authority (i.e. not explicitly).
- b) the TE/X.25 DTE+TA identity is made known to the AU when setting up the Frame Relay SVC using one of the methods described in 2.4/X.32.

NOTE 2 – It is for further study to determine the applicability of the identification method provided by means of the Link Layer XID procedure specified in 2.4.1.2/X.32 to the Q.922 Data Link Layer protocol.

The service offered for an unidentified TE/X.25 DTE+TA is as specified in 2.3.2.1/X.32. In addition when establishing a Frame Relay SVC through the FRPDN to an unidentified TE/X.25 DTE+TA, the AU sets the subparameters of the Link Layer Core Parameters information element in the X.36 SETUP message to network-specific default values.

The service offered for an identified TE/X.25 DTE+TA is as specified in 2.3.2.2/X.32. In addition when establishing a Frame Relay SVC through the FRPDN to an identified TE/X.25 DTE+TA, the AU sets the subparameters of the Link Layer Core Parameters information element in the X.36 SETUP message to TE/X.25 DTE+TA-specific values.

- In the call control mapping method of interworking, it is for further study to determine the need for a requirement to identify the TE/X.25 DTE+TA by the AU.

Every TE/X.25 DTE+TA will be allocated one or more numbers to identify the port on the FRPDN. FRPDNs may be numbered according to the numbering plan specified in either Recommendation X.121 or E.164. The method for X.25 packets to convey numbers between the two numbering plans is specified in Recommendation X.122/E.166.

7.1.2 User access capabilities

In this case, DTEs belonging to user classes of service 30 to 61 of Recommendation X.1 (categories of access W1 to W32, X1 to X32, Y1 to Y32, and Z1 to Z32) can be supported with no restrictions on the use of Recommendation X.25.

7.1.3 Basic rules

A distinction is made between the two methods of interworking (i.e. port access, call control mapping, see Recommendation X.300) that may be used when accessing PSDTS.

- In the port access method of interworking, access to PSDTS will be established by separating the establishment phase of the Frame Relay SVC and the control phase of the X.25 virtual circuits using X.25 PLP. The Frame Relay SVC will employ the X.36 signalling procedure (see Recommendation X.36).
- In the call control mapping method of interworking, access to PSDTS will be established in a single step. The establishment phase of the Frame Relay SVC and the control phase of the X.25 virtual call are integrated into a single procedure. The detailed specification of this procedure is for further study.

7.2 Access to PSDTS using the ISDN Frame Relaying Services

Interworking considerations are defined in clause 9.

7.2.1 Service characteristics

In this case, the ISDN offers a Frame Relay PVC or SVC between a TE/TA and an AU port. In the Frame Relay SVC case, the AU must be selected by the called party address information element of a Q.933 SETUP message at the ISDN user-network interface when the TE/TA sets up the Frame Relay SVC to the AU. In the Frame Relay PVC access case, Q.933 signalling protocol messages are not used.

As described in 7.1.1 above, a distinction in the service characteristics is made between the two methods of interworking (i.e. port access, call control mapping) that may be used to access PSDTS. The TE/X.25 DTE+TA identification considerations described in 7.1.1 above apply by replacing "FRPDN" with "ISDN".

Every TE/X.25 DTE+TA will be associated with one or more ISDN (E.164) numbers for frame relaying services. In case of access to PSDTS of ISDN, the TE/X.25 DTE+TA may be associated with the same E.164 number(s) for packet switching services or different numbers may be assigned by the ISDN for the two services. In case of access to PSDTS of PSPDN, the TE/X.25 DTE+TA may also be associated with one or more X.121 numbers assigned by the PSPDN. The method for X.25 packets to convey numbers between the two numbering plans is specified in Recommendation X.122/E.166.

7.2.2 User access capabilities

The Frame Relay virtual circuit procedures to access PSDTS specified in this Recommendation can be used at the D-, B- and H-channels of an ISDN user-network interface in case the ISDN service provider chooses to locate an FH function in the local exchange serving the user interface (see 6.2). If the FH function is located at a remote interface, the Frame Relay virtual circuit procedures of this Recommendation cannot be used on the D-channel. The procedures apply at the B- and H-channels of the ISDN user-network interface.

7.2.2.1 Access through the D-Channel

In this case, DTEs belonging to user classes of service 8 to 10, 11 and 30 of Recommendation X.1 (categories of access IFB1 to IFB5, IFD1 to IFD5, IFF1 to IFF5 and IFH1 to IFH5) can be supported subject to the limitation described below.

A limitation is imposed by Q.922 in regard to the maximum I-field length of the Information frames (parameter N201 as defined in Recommendation Q.922). The maximum number of octets in the Information field of each frame transferred on the D-channel shall be 260 octets.

The range of Data Link Connection Identifiers available on a D-channel for support of user information is given in Table 1/Q.922.

7.2.2.2 Access through the B-Channel

In this case, DTEs belonging to user classes of service 8 to 10, 11 and 30 to 61 of Recommendation X.1 (categories of access IFA1 to IFA36, IFC1 to IFC36, IFE1 to IFE36 and IFG1 to IFG36) can be supported with no restrictions on the use of Recommendation X.25.

The range of Data Link Connection Identifiers available on a B-channel for support of user information is given in Table 1/Q.922.

The range of Data Link Connection Identifiers available on an H-channel for support of user information is given in Table 1/Q.922.

7.2.3 Basic rules

The considerations described in 7.1.3 above apply by replacing "X.36" with "Q.933".

8 Addressing and routing aspects

8.1 Access to PSDTS via an FRPDN

8.1.1 Outgoing call

8.1.1.1 Access Unit selection

A distinction is made between the two methods of interworking that may be used to access PSDTS.

- In the port access method of interworking, the responsibility to invoke the AU is with the calling TE/X.25 DTE+TA. If a Frame Relay virtual circuit (PVC or SVC) is not established between the calling DTE/X.25 DTE+TA and the AU, it is the responsibility of the calling TE/X.25 DTE+TA to establish the Frame Relay virtual circuit to the AU before being able to establish any X.25 virtual call to a remote DTE.
- In the call control mapping method of interworking, it is the network responsibility to invoke the AU, if needed. The calling TE/X.25 DTE+TA establishes a Frame Relay SVC towards the remote called DTE without being aware that an AU may be required to complete the call to its destination. The AU which is invoked by the network, if needed, provides the mapping between the Frame Relay protocol procedures and the X.25 protocol procedures.

8.1.1.2 Addressing scheme

An AU port will be assigned an FRPDN address.

- In the port access method of interworking, the called party number information element of the X.36 SETUP message contains the address of the AU. An X.25 call request packet sent over the Frame Relay SVC contains the address of a remote called DTE.
- In the call control mapping method of interworking, the called party number information element of the X.36 SETUP message contains the address of the remote called DTE.

8.1.2 Incoming call

8.1.2.1 Access Unit selection

When the network providing PSDTS (e.g. PSPDN or ISDN) is connected to other networks, the guidelines outlined below may be used to select an AU to complete an incoming X.25 virtual call to the called TE/X.25 DTE+TA.

8.1.2.1.1 Access Unit selection by PSPDN

The following criteria may be used by PSPDN to complete an incoming X.25 virtual call to the called TE/X.25 DTE+TA:

- If the called address is an X.121 address, two cases are considered:
 - 1) The FRPDN, which is connected to the PSPDN, assigns addresses to its endpoints according to the E.164 numbering plan. In this case, no AU is selected and the PSPDN applies its normal routing procedures to complete the incoming X.25 virtual call.
 - 2) The FRPDN assigns addresses to its endpoints according to the X.121 numbering plan and shares the Data Network Identification Code (DNIC) with the PSPDN.
 - a) In case the called DTE is registered with the PSPDN and the subscription parameters indicates “Packet Mode”, no AU is selected and the PSPDN applies its normal routing procedures.

- b) In case the called DTE is registered with the PSPDN and the subscription parameters indicates “Frame Relay”, the PSPDN selects an AU (with functionality as specified in this Recommendation) to complete the incoming call to the FRPDN. The procedures in 10.1 apply.
 - c) In case the called DTE is not registered with the PSPDN, the PSPDN selects an AU to complete the incoming call to the FRPDN and the procedures in 10.1 apply.
- If the called address is an E.164 address, two cases are considered:
 - 1) The FRPDN, which is connected to the PSPDN, assigns addresses to its endpoints according to the X.121 numbering plan. In this case, the PSPDN selects an AU to complete the incoming call to the ISDN. The criteria that may be used by the AU to select the ISDN bearer service to complete the call are outlined in 8.2.2.1.1.
 - 2) The FRPDN assigns addresses to its endpoints according to the E.164 numbering plan. The criteria that may be used to select the AU are outlined in 8.2.2.1.1.

8.1.2.1.2 Access Unit selection by ISDN

The following criteria may be used by ISDN to complete an incoming X.25 virtual call to the called TE/X.25 DTE+TA:

- If the called address is an X.121 address, two cases are considered:
 - 1) The FRPDN, which is connected to the ISDN, assigns addresses to its endpoints according to the E.164 numbering plan. In this case, the ISDN selects an X.75 interface to a PSPDN to complete the incoming call.
 - 2) The FRPDN assigns addresses to its endpoints according to the X.121 numbering plan.
 - a) In case the called DTE is registered with the ISDN and the subscription parameters indicates “Packet Mode”, the ISDN selects an X.75 interface to a PSPDN to complete the incoming X.25 virtual call.
 - b) In case the called DTE is registered with the ISDN and the subscription parameters indicates “Frame Relay”, the ISDN selects an AU (with functionality as specified in this Recommendation) to complete the incoming X.25 virtual call to the FRPDN. The procedures specified in 10.1 apply.
 - c) In case the called DTE is not registered with the ISDN, the ISDN selects an X.75 interface to a PSPDN to complete the incoming call.
- If the called address is an E.164 address, the criteria that may be used to select the AU are outlined in 8.2.2.1.2.

8.1.2.2 Addressing scheme

- In the port access method of interworking, the called party number information element of an X.36 SETUP message contains the address of the called TE/X.25 DTE+TA. The calling party number information element of the SETUP message may contain the address of the AU. An X.25 call request packet sent over the Frame Relay SVC may contain the address of the called TE/X.25 DTE+TA and contains the calling address of the remote DTE.
- In the call control mapping method of interworking, the called party number information element of the X.36 SETUP message contains the address of the called TE/X.25 DTE+TA. The calling party number information element of the SETUP message may contain the address of the remote DTE.

8.2 Access to PSDTS using the ISDN Frame Relaying Services

8.2.1 Outgoing call

8.2.1.1 Access Unit selection

The considerations described in 8.1.1.1 above apply.

8.2.1.2 Addressing scheme

The considerations described in 8.1.1.2 above apply by replacing “X.36” with “Q.933”.

8.2.2 Incoming call

8.2.2.1 Access Unit selection

The network providing PSDTS (e.g. PSPDN or ISDN) may use the guidelines outlined below to select an AU in order to complete an incoming X.25 virtual call via ISDN to the called TE/X.25 DTE+TA.

8.2.2.1.1 Access Unit selection by PSPDN

The following criteria may be used by PSPDN to select an AU to the ISDN. Typically the PSPDN, based on arrangements with the ISDN, will have knowledge regarding the bearer services supported by the ISDN.

- If the Circuit Switched Bearer Service (CSBS) is the only bearer service supported by the ISDN, the PSPDN selects a X.31 AU function. The procedures specified in Case A of Recommendation X.31 apply.
- If the Packet Mode Bearer service (PMBS) (also referred to as the ISDN Virtual Circuit Service) is the only bearer service supported by the ISDN, the PSPDN selects an X.75 interface to the ISDN. See Recommendation X.31.
- If the Frame Relay Bearer Service (FRBS) is the only bearer service supported by the ISDN, the PSPDN selects an AU (with functionality as specified in this Recommendation) and the procedures specified in 10.2 below apply.
- If the ISDN supports PMBS and FRBS and the called DTE is registered with the PSPDN:
 - In case the called DTE subscription parameters indicate “Frame Relay”, the PSPDN selects an AU function (with functionality as specified in this Recommendation) and the procedures specified in 10.2 below apply.
 - In case the called DTE subscription parameters indicate “Packet Mode”, the PSPDN selects an X.75 interface to the ISDN. See Recommendation X.31.
- If the ISDN supports PMBS and FRBS and the called DTE is not registered with the PSPDN, the PSPDN selects an X.75 interface to the ISDN.

8.2.2.1.2 Access Unit selection by ISDN

The following criteria may be used by the ISDN to complete an incoming X.25 virtual call to the called TE/X.25 DTE+TA.

- The ISDN determines from the called address that the called TE/X.25 DTE+TA is one of its endpoints. If the called DTE subscription parameters indicate “Frame Relay”, the ISDN offers the incoming X.25 virtual call to the called DTE using the procedures specified in Recommendation Q.933. If the called DTE subscription parameters indicate “Packet Mode”, the ISDN offers the incoming X.25 virtual call to the called DTE using the procedures for Case B of Recommendation X.31.
- The ISDN determines from the called address that interworking with an adjacent ISDN is required. Based on arrangements with the adjacent ISDN, the ISDN will have knowledge regarding the bearer services supported by the adjacent ISDN. The ISDN may then use the criteria described in 8.2.2.1.1 to select an AU to complete the call.

8.2.2.2 Addressing scheme

The considerations described in 8.1.2.2 above apply by replacing “X.36” with “Q.933”.

8.2.2.3 Called TE/X.25 DTE+TA interface selection

This subclause describes the information necessary to select a compatible TE/X.25 DTE+TA for the completion of an incoming Frame Relay SVC.

It is envisaged that an ISDN would identify, by means of an ISDN address, a specific interface within the subscriber premises. The transmission capability information may be used by the called TE/X.25 DTE+TA for compatibility checking purposes.

A Data Link Connection Identifier value may be used for terminal identification for PVC service. Other methods are for further study.

In general, an ISDN number identifies one or more ISDN user-network interfaces. However, some networks may allow an ISDN user-network interface to be allocated more than one ISDN number, thus allowing the identification of a given terminal within an ISDN user-network interface.

There are two ways of selecting a specific terminal in the ISDN. One is by means of the ISDN supplementary services Multiple Subscriber Number (MSN) or Direct-Dialling-In (DDI), the second is by means of ISDN subaddressing.

- *Terminal Interface Selection by means of MSN/DDI*

In a point to multipoint configuration, the ISDN supplementary service MSN may be used to select a specific terminal.

In a point to point configuration, the ISDN supplementary service DDI may be used to select a specific terminal.

- *Terminal Interface Selection by means of ISDN Subaddressing*

A subaddress from the ISDN called party subaddress may be used to identify a specific terminal within a user installation in a point to point or point to multipoint configuration.

8.2.2.4 ISDN channel type selection

Two procedures are available regarding the manner in which channel type selection (i.e. selecting among D-, B- or H-channel type) can be performed:

- i) the terminal which is to accept the incoming Frame Relay SVC will indicate the channel type to be used;
- ii) the ISDN has information regarding the channel type to be used for the incoming Frame Relay SVC.

The various sorts of information that the ISDN may use to determine the channel type may include, but are not limited to:

- a) subscription time agreements;
- b) occupancy level on established channels.

Channel negotiation procedures may be found in clause 10.

9 Interworking with dedicated networks

Interworking by both port access and call control mapping (see Recommendation X.300) is possible.

This Recommendation specifies the procedures for interworking by the port access method. Interworking by the call control mapping method is for further study.

9.1 Access to PSDTS via an FRPDN

A TE/X.25 DTE+TA accesses the access port, referred to as AU, in the network providing the PSDTS by means of a Frame Relay virtual circuit through the FRPDN. The AU belongs to the network providing the PSDTS and is functionally equivalent to an IWF (see Recommendation X.328 in case the network providing the PSDTS is an ISDN).

In some implementations, the AU function logically belonging to the network providing the PSDTS may reside physically in a node in the FRPDN. The service provided by the FRPDN is still FRDTS and the interworking between the FRPDN and the network providing the PSDTS is effected through use of an X.75 interface or a functionally equivalent internal network protocol.

9.2 Access to PSDTS using the ISDN Frame Relaying services

A TE/X.25 DTE+TA accesses the access port, referred to as AU, in the network providing the PSDTS by means of a Frame Relay virtual circuit through the ISDN. The AU belongs to the network providing the PSDTS and is functionally equivalent to an IWF (see Recommendation X.325 in case the network providing the PSDTS is a PSPDN and Recommendation X.320 in case the network providing the PSDTS is an ISDN).

In some implementations, the AU function logically belonging to the network providing the PSDTS may reside physically in a node in the ISDN providing the Frame Relaying services. The service provided by this ISDN is still Frame Relaying services and the interworking between it and the network providing the PSDTS is effected through use of an X.75 interface or a functionally equivalent internal network protocol.

Note that in some implementations the same ISDN may be providing both the PSDTS and the Frame Relaying services.

10 Procedures

10.1 Access to PSDTS via an FRPDN

10.1.1 General

The procedures specified in this Recommendation are based on the port access method of interworking.

NOTE – Procedures based on the call control mapping of interworking are for further study.

As described in 6.1 above, a Frame Relay virtual circuit is established between the TE/X.25 DTE+TA and the AU. A Frame Relay SVC is established using the procedures specified in 10.1.2 below.

The Frame Relay virtual circuit may be either a PVC or an SVC.

A Frame Relay PVC is established by means which are beyond the scope of this Recommendation. The procedures for PVC management specified in Recommendation X.36 apply.

In this Recommendation, the terms “outgoing” and “incoming” are used to describe the virtual circuit as viewed by the user side of the FRPDN user-network interface (i.e. as viewed by the TE/X.25 DTE+TA).

10.1.2 Outgoing call

A calling TE/X.25 DTE+TA, wishing to set up an X.25 virtual call to a remote DTE, uses a Frame Relay virtual circuit that is established through the FRPDN to the AU. The Frame Relay virtual circuit is established on a Data Link Connection within the TE/X.25 DTE+TA – DCE interface. The Frame Relay virtual circuit may be either a PVC or an SVC.

NOTES

1 If a Frame Relay virtual circuit is not established through the FRPDN to the AU, the calling TE/X.25 DTE+TA uses the procedures specified in 10.1.2.1 below before setting up the X.25 virtual call.

2 If a Frame Relay PVC is established through the FRPDN, then X.25 PVCs as well as X.25 virtual calls may be established between the calling TE/X.25 DTE+TA and remote DTEs.

10.1.2.1 Outgoing Frame Relay Switched Virtual Circuit

A calling TE/X.25 DTE+TA uses the following procedures:

- 1) The procedures specified in 10.7.1.2/X.36 for the Frame Relay virtual circuit setup. In the SETUP message sent by the calling TE/X.25 DTE+TA:
 - i) The Called Party Address information element contains the address of the AU.
 - ii) The Low Layer Compatibility information element may be included to pass compatibility information from the calling TE/X.25 DTE+TA to the AU. The Layer 3 protocol (octet 5 of the Low Layer Compatibility information element) is encoded as X.25 PLP. The Layer 2 protocol (Octet 6 of

the Low Layer Compatibility information element) is encoded as Recommendation X.25. Octet 6a of the Low Layer Compatibility information element is present to indicate that the address field of the LAPB frame is included when encapsulating the LAPB frame in the Q.922 core frame.

- 2) The procedures specified in 10.7.1.3.1/X.36 for Data Link Connection negotiation.
- 3) The Procedures specified in 10.7.1.3.2/X.36 to request a certain Quality of Service (QOS).

10.1.2.2 Outgoing X.25 virtual call

The X.25 PLP procedures specified in Recommendation X.25 apply.

NOTE 1 – A logical channel number is unique within a Data Link Connection Identifier.

The mapping between LAPB frames and X.36 frames is performed by encapsulating a LAPB frame in an X.36 frame according to Recommendation I.555. The LAPB Address field, LAPB Control field and LAPB Information field are encapsulated in the X.36 frame as illustrated in Figure 10-1. The Frame Check Sequence (FCS) field of the LAPB frame is stripped off and a new FCS field is calculated for the X.36 frame including the X.36 Address field and Information field.

NOTE 2 – The X.36 Address field includes the Data Link Connection Identifier and Forward Explicit Congestion Notification (FECN), Backward Explicit Congestion Notification (BECN), Discard Eligibility (DE), Command/Response (C/R) and Extension Address (EA) bits.

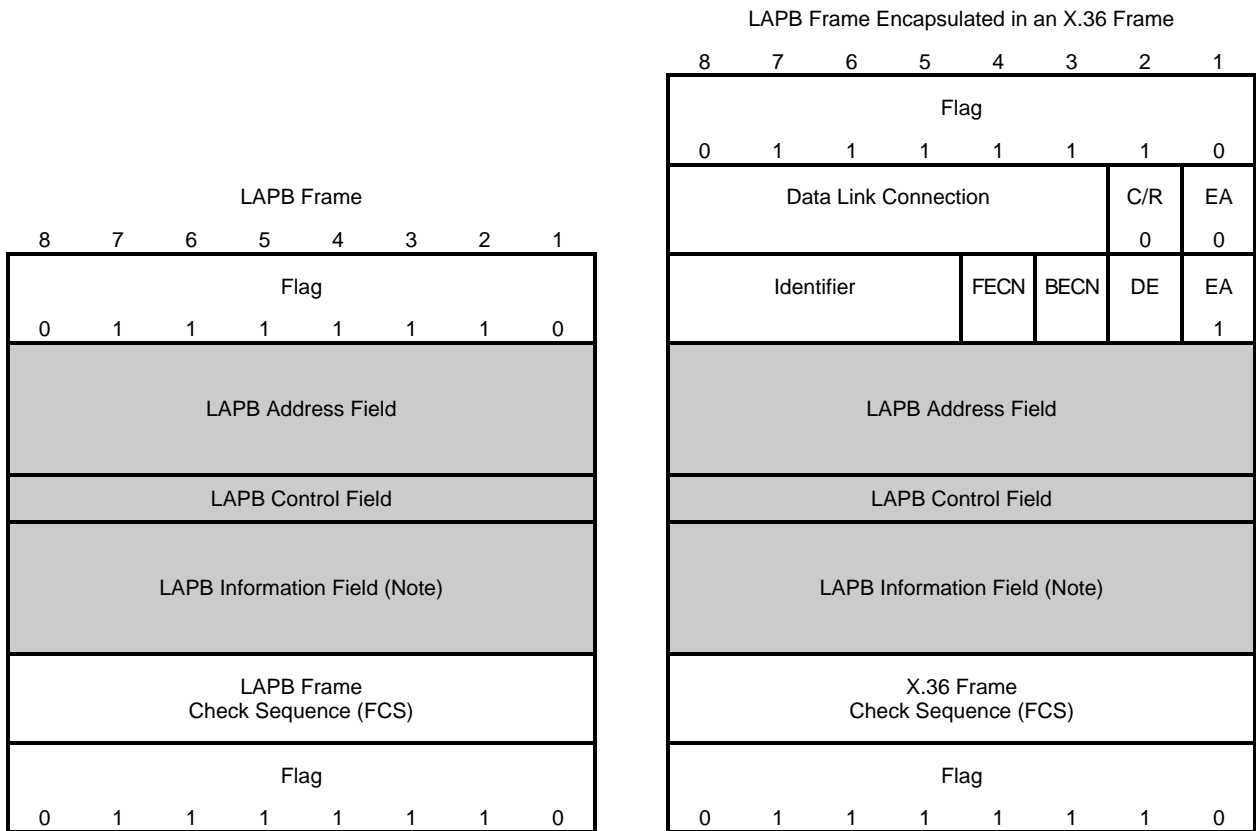

NOTE – The Information field is not present in LAPB Supervisory frames.

FIGURE 10.1/X.33

Encapsulation of LAPB Frame in X.36 Frame

10.1.3 Incoming call

The AU delivers an incoming X.25 virtual call over an established Frame Relay virtual circuit to the called TE/X.25 DTE+TA. If more than one Frame Relay virtual circuit is established to the called TE/X.25 DTE+TA, the AU selects one of these Frame Relay virtual circuits to deliver the incoming X.25 virtual call. The AU may use the occupancy levels of these Frame Relay virtual circuits to perform the selection. If the selection procedure is unsuccessful or if no Frame Relay virtual circuit is established to the called TE/X.25 DTE+TA, the AU initiates the procedures specified below for establishing a Frame Relay SVC before delivering the incoming X.25 virtual call.

10.1.3.1 Incoming Frame Relay Switched Virtual Circuit

The FRPDN uses the following procedures:

- 1) The procedures specified in 10.7.2.2/X.36 for the Frame Relay switched virtual circuit setup. In the X.36 message sent by the FRPDN DCE to the called TE/X.25 DTE+TA:
 - i) The Called Party Address information element contains the address of the called TE/X.25 DTE+TA.
 - ii) The Low Layer Compatibility information elements included, if received from the AU, to pass compatibility information from the AU to the called TE/X.25 DTE+TA. The FRPDN passes unchanged the low layer compatibility information received from the AU. The Layer 3 protocol (octet 5 of the Low Layer Compatibility information element) should be encoded as X.25 PLP. The Layer 2 protocol (octet 6 of the Low Layer Compatibility information element) should be encoded as Recommendation X.25. Octet 6a of the Low Layer Compatibility information element should be present to indicate that the Address field of the LAPB frame is included when encapsulating the LAPB frame in the Q.922 core frame.
 - iii) The characteristics of the Frame Relay SVC may be determined from subscription time agreements information.
 - If the called TE/X.25 DTE+TA is administratively registered with the Administration of the network providing the PSDTS and is successfully identified to the AU, the subparameters of the Link Layer Core Parameter information element in the X.36 SETUP message sent by the AU to the called TE/X.25 DTE+TA are set to the TA/X.25 DTE+TA specific values determined at subscription time.
 - If the called TE/X.25 DTE+TA is not registered or is registered but is not successfully identified to the AU, the subparameters of the Link Layer Core Parameter information element in the X.36 SETUP message sent by the AU to the called TE/X.25 DTE+TA are set to default values determined by the AU.
- 2) The procedures specified in 10.7.2.3.1/X.36 for Data Link Connection Identifier negotiation.

Upon receipt of an X.36 SETUP message on the Data Link Connection identified by DLCI = 0, the called TE/X.25 DTE+TA follows the procedures specified in 10.7.2.3.2/X.36 for parameter negotiation.

10.1.3.2 Incoming X.25 virtual call

The X.25 PLP procedures specified in Recommendation X.25 apply.

NOTE – A logical channel number is unique within a Data link Connection.

The encapsulation procedure of LAPB Frames in X.36 frames is specified in 10.1.2.2 above. The reverse procedure of this encapsulation procedure is performed as follows. The X.36 Address field and FCS field are stripped off and a new LAPB FCS field is calculated including the LAPB Address field, Control field and Information field. Note that the C/R bit in the Address field of the X.36 frame is not used and is set to zero. See Figure 10-1.

10.1.4 Frame Relay Switched Virtual Circuit Access Collision

The access collision procedures specified in 10.9/X.36 apply.

10.1.5 Frame Relay Switched Virtual Circuit Clearing

10.1.5.1 Clearing initiated by the TE/X.25 DTE+TA

The procedures specified in 10.7.4.3/X.36 apply.

10.1.5.2 Clearing initiated by the FRPDN

The procedures specified in 10.7.4.4/X.36 apply.

10.1.6 Restart procedures

The procedures specified in 10.8/X.36 apply.

10.1.7 Handling of error conditions

The procedures for handling of error conditions specified in 10.10/X.36 apply.

In addition, the following rules apply:

- 1) If an X.36 clearing message is received from the FRPDN by the AU while X.25 virtual call(s) still exist, the AU clears the X.25 virtual call(s) with cause #17 "remote procedure error" and diagnostic code #64 "call setup, call clearing, or registration problem."
- 2) If the establishment of a Frame Relay SVC that is triggered by an incoming X.25 virtual call is rejected by the called TE/X.25 DTE+TA using X.36 messages on the Data Link Connection identified by DLCI = 0, the AU clears the incoming X.25 virtual call using an appropriate cause from Table 11-5/X.31.

NOTE 1 – In Table 11-5/X.31, Q.931 is replaced with X.36.

- 3) If a condition exists that prevents an X.36 SETUP message that is triggered by an incoming X.25 virtual call from being delivered to the called TE/X.25 DTE+TA on the Data Link Connection identified by DLCI = 0, the AU clears the incoming X.25 virtual call with a cause that is selected appropriate to the condition from Table 11-5/X.31.
- 4) If an X.36 SETUP message is sent as a result of an incoming X.25 virtual call on a Data Link Connection identified by DLCI = 0 to the called TE/X.25 DTE+TA and no response is received prior to the second expiry of Timer T303, rule 3) above applies.
- 5) If an X.36 SETUP message is sent as a result of an incoming X.25 virtual call on a Data Link Connection identified by DLCI = 0 to the called TE/X.25 DTE+TA and a response is received which results in the clearing of the Frame Relay SVC, the AU clears the incoming X.25 virtual call using the appropriate cause from Table 11-5/X.31 relative to the cause sent in the clearing message.
- 6) If an X.25 clear request packet is received by the AU via its network prior to the delivery of the X.25 incoming call packet to the called TE/X.25 DTE+TA (premature clearing), an X.25 *clear confirmation* packet is sent to the calling DTE and the Frame Relay switched virtual circuit is cleared, when and if established. In the X.36 clearing message, the AU uses the appropriate cause as described in Table 11-6/X.31.

NOTE 2 – In Table 11-6/X.31, Q.931 is replaced with X.36.

10.2 Access to PSDTS using the ISDN Frame Relaying Services

10.2.1 General

The procedures specified in this Recommendation are based on the port access method of interworking.

NOTE – Procedures based on the call control mapping of interworking are for further study.

As described in 6.2 above, a Frame Relay virtual circuit is established between the TE/X.25 DTE+TA and the AU. A Frame Relay SVC is established using the procedures specified in 10.2.2 and 10.2.3 below. The procedures specified in 10.2.2, referred to as Case A, are based on the procedures for Case A of Recommendation Q.933. These procedures

apply when the ISDN Frame Handler (FH) function is located in a remote exchange (see 6.2/Q.933 and 6.4/Q.933). The procedures specified in 10.2.3, referred to as Case B, are based on the procedures for Case B of Recommendation Q.933. These procedures apply when the ISDN FH is located in the local exchange.

The Frame Relay virtual circuit may be either a PVC or a SVC.

A Frame Relay PVC is established by means which are beyond the scope of this Recommendation. The procedures specified in Annex A/Q.933 are used for Frame Relay PVC management.

In this Recommendation, the terms “outgoing” and “incoming” are used to describe the call as viewed by the user side of the ISDN user-network interface (i.e. as viewed by the TE/X.25 DTE+TA).

10.2.2 Case A procedures

A TE/X.25 DTE+TA accesses PSDTS by setting up a Frame Relay virtual circuit over a circuit-switched access connection through the ISDN to the AU. B- and/or H-channels can be used for access at the ISDN user-network interface.

The TE/X.25 DTE+TA circuit-switched access connection to the ISDN must first be in place before the Frame Relay virtual circuits can be established. This circuit-switched access connection may be set up either on a permanent (i.e. non-switched) basis or on a demand (i.e. switched) basis by procedures beyond the scope of this Recommendation.

NOTE 1 – If the circuit-switched access connection is not established, the calling TE/X.25 DTE+TA may use the procedures specified in 5.1.1.1/Q.931 to establish such a connection before setting up a Frame Relay SVC.

Over a TE/X.25 DTE+TA permanent circuit-switched access connection, Frame Relay PVCs and or Frame Relay SVCs may be established. Over a TE/X.25 DTE+TA demand circuit-switched access connection, only Frame Relay SVCs may be established.

NOTE 2 – Frame Relay PVCs over a demand circuit-switched access connection are not allowed.

Within the TE/X.25 DTE+TA circuit-switched access connection to the ISDN (either a permanent or a demand access connection), in-channel signalling as specified for Case A of Recommendation Q.933 is used to establish Frame Relay SVCs. In-channel signalling is employed on the logical link identified by DLCI = 0. The Link Layer protocol employed on the DLCI = 0 logical link is Link Access Procedures to Frame Mode Bearer Services (LAPF) which is specified in Recommendation Q.922.

10.2.2.1 Outgoing call

A calling TE/X.25 DTE+TA, wishing to set up an X.25 virtual call to a remote DTE, uses a Frame Relay virtual circuit that is established through the ISDN to the AU. The Frame Relay virtual circuit is established on a Data Link Connection available for support of user information (see Table 1/Q.922) within B- or H-channel on the ISDN user-network interface. The Frame Relay virtual circuit may be either a PVC or an SVC.

NOTES

1 If a Frame Relay virtual circuit is not established through the ISDN to the AU, the calling TE/X.25 DTE+TA uses the procedures specified in 10.2.2.1.1 below before setting up the X.25 virtual call.

2 If a Frame Relay PVC is established through the ISDN, then X.25 PVCs as well as X.25 virtual calls may be established between the calling TE/X.25 DTE+TA and remote DTEs.

10.2.2.1.1 Outgoing Frame Relay Switched Virtual Circuit

A calling TE/X.25 DTE+TA uses the following procedures:

- 1) The procedures specified in 5.1.1.2/Q.933 for the Frame Relay connection set-up. In the SETUP message sent by the calling TE/X.25 DTE+TA:
 - i) The Called Party Address information element contains the address of the AU.
 - ii) The Bearer Capability information element shall be encoded as follows:
 - information transfer capability set to “unrestricted digital information”;
 - transfer mode set to “frame mode”;
 - user information Layer 2 protocol set to “core aspects of frame mode”.
 - iii) The Low Layer Compatibility information element may be included to pass compatibility information from the calling TE/X.25 DTE+TA to the AU. The Layer 3 protocol (octet 5 of the Low Layer Compatibility information element) is encoded as X.25 PLP. The Layer 2 protocol (Octet 6 of the Low Layer Compatibility information element) is encoded as Recommendation X.25. Octet 6a of the Low Layer Compatibility information element is present to indicate that the address field of the LAPB frame is included when encapsulating the LAPB frame in the Q.922 core frame.
- 2) The procedures specified for Case A in 5.1.3.1/Q.933 for channel negotiation.
- 3) The procedures specified for Case A in 5.1.3.2/Q.933 for Data Link Connection negotiation.
- 4) The procedures specified in 5.1.3.3.2/Q.933 to request a certain Quality of Service (QOS).

10.2.2.1.2 Outgoing X.25 Virtual Call

The X.25 PLP procedures specified in Recommendation X.25 apply.

NOTE 1 – A logical channel number is unique within a Data Link Connection.

The mapping between LAPB frames and Q.922 core frames is performed by encapsulating a LAPB frame in a Q.922 core frame according to Recommendation I.555. The LAPB Address field, LAPB Control field and LAPB Information field are encapsulated in the Q.922 core frame as illustrated in Figure 10-2. The Frame Check Sequence (FCS) field of the LAPB frame is stripped off and a new FCS field is calculated for the Q.922 core frame including the Q.922 core Address field and Information field.

NOTE 2 – The Q.922 core Address field includes the Data Link Connection Identifier and FECN, BECN, DE, C/R and EA bits.

10.2.2.2 Incoming call

The AU delivers an incoming X.25 virtual call over an established Frame Relay virtual circuit to the called TE/X.25 DTE+TA. If more than one Frame Relay virtual circuit is established to the called TE/X.25 DTE+TA, the AU selects one of these Frame Relay virtual circuits to deliver the incoming X.25 virtual call. The AU may use the occupancy levels of these Frame Relay virtual circuits to perform the selection. If the selection procedure is unsuccessful or if no Frame Relay virtual circuit is established to the called TE/X.25 DTE+TA, the AU initiates the procedures specified below for establishing a Frame Relay SVC before delivering the incoming X.25 virtual call. However, a circuit-switched access connection to the called TE/X.25 DTE+TA must be in place before the AU can establish a Frame Relay SVC to the called TE/X.25 DTE+TA.

NOTE – If such a connection is not already established, the network may use the procedures specified in 5.2.1.1/Q.933 to establish a connection prior to attempting the establishment of the Frame Relay SVC.

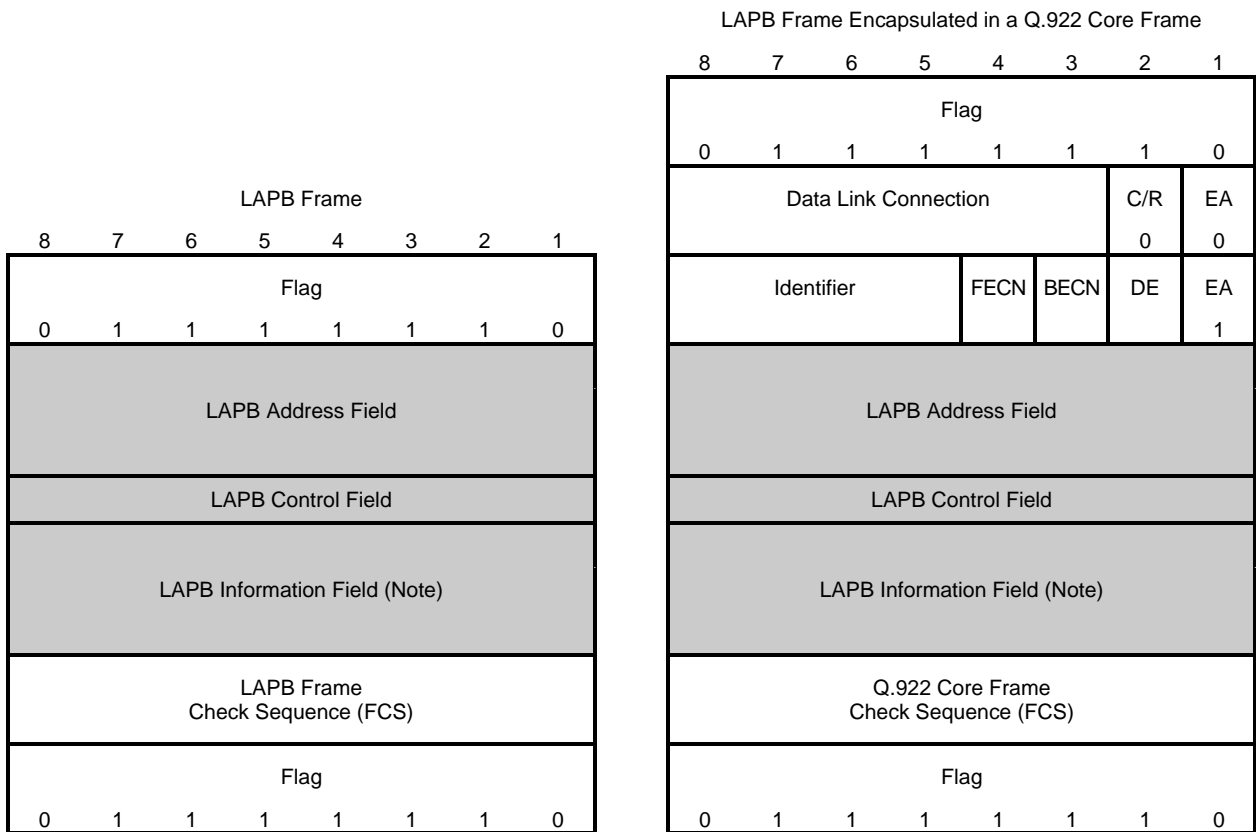

NOTE – The Information field is not present in LAPB Supervisory frames.

FIGURE 10-2/X.33

Encapsulation of LAPB Frame in Q.922 Core Frame

10.2.2.2.1 Incoming Frame Relay Switched Virtual Circuit

The network uses the following procedures:

- 1) The procedures specified in 5.2.1.2/Q.933 for the Frame Relay connection setup. In the Q.933 SETUP message sent by the ISDN to the called TE/X.25 DTE+TA:
 - i) The Called Party Address information element in the SETUP message contains the address of the called TE/X.25 DTE+TA.
 - ii) The Bearer Capability information element shall be encoded as specified in 10.2.2.1.1 above.
 - iii) The Low Layer Compatibility information elements included, if received from the AU, to pass compatibility information from the AU to the called TE/X.25 DTE+TA. The ISDN passes unchanged the low layer compatibility information received from the AU. The Layer 3 protocol (octet 5 of the Low Layer Compatibility information element) should be encoded as X.25 PLP. The Layer 2 protocol (octet 6 of the Low Layer Compatibility information element) should be encoded as Recommendation X.25. Octet 6a of the Low Layer Compatibility information element should be present to indicate that the Address field of the LAPB frame is included when encapsulating the LAPB frame in the Q.922 core frame.

- iv) The characteristics of the Frame Relay SVC may be determined from subscription time agreements information.
 - If the called TE/X.25 DTE+TA is administratively registered with the Administration of the network providing the PSDTS and is successfully identified to the AU, the subparameters of the Link Layer Core Parameter information element in the Q.933 SETUP message sent by the PSPDN AU to the called TE/X.25 DTE+TA are set to the TE/X.25 DTE+TA specific values determined at subscription time.
 - If the called TE/X.25 DTE+TA is not registered or is registered but is not successfully identified to the AU, the subparameters of the Link Layer Core Parameter information element in the Q.933 SETUP message sent by the AU to the called TE/X.25 DTE+TA are set to default values determined by the AU.
- 2) The procedures specified in 5.2.3.1.1/Q.933 for channel selection through call offering.
- 3) The procedures specified for Case A in 5.2.3.2/Q.933 for Data Link Connection negotiation.

Upon receipt of a Q.933 SETUP message on the Data Link Connection identified by DLCI=0, the called TE/X.25 DTE+TA follows the procedures specified in 5.2.3.3/Q.933 for parameter negotiation.

10.2.2.2.2 Incoming X.25 Virtual Call

The X.25 PLP procedures specified in Recommendation X.25 apply.

NOTE – A logical channel number is unique within a Data Link Connection.

The encapsulation procedure of LAPB Frames in Q.922 core frames is specified in 10.2.2.1.2 above. The reverse procedure of this encapsulation procedure is performed as follows. The Q.922 core Address field and FCS field are stripped off and a new LAPB FCS field is calculated including the LAPB Address field, Control field and Information field. Note that the C/R bit in the Address field of the Q.922 core frame is not used and is set to zero. See Figure 10-2.

10.2.3 Case B procedures

A TE/X.25 DTE+TA accesses PSDTS by setting up a Frame Relay virtual circuit through the ISDN to the AU. D-, B- and/or H-channels can be used for access at the ISDN user-network interface.

The physical access connection of the TE/X.25 DTE+TA to the ISDN may be set up either on a permanent (i.e. non-switched) basis or on a demand (i.e. switched) basis. In the permanent case, procedures which are beyond the scope of this Recommendation (e.g. administrative, management procedures) are followed for establishment and release of a physical access connection. In the demand case, the procedures to establish a demand physical access connection are integrated with the procedures to establish a Frame Relay SVC. The procedures used by either the TE/X.25 DTE+TA or the network to establish the first Frame Relay SVC will establish the TE/X.25 DTE+TA physical access connection at the ISDN user-network interface, if it is not already established. The procedures used by either the TE/X.25 DTE+TA or the network to clear the last Frame Relay SVC will disconnect the TE/X.25 DTE+TA physical access connection at the ISDN user-network interface.

Over a TE/X.25 DTE+TA permanent access connection to the ISDN, Frame Relay PVCs and or Frame Relay SVCs may be established. Over a TE/X.25 DTE+TA demand access connection, only Frame Relay SVCs may be established.

NOTE – Frame Relay PVCs over a demand access connection are not allowed.

10.2.3.1 Outgoing call

A calling TE/X.25 DTE+TA, wishing to set up an X.25 virtual call to a remote DTE, uses a Frame Relay virtual circuit that is established through the ISDN to the AU. The Frame Relay virtual circuit is established on a Data Link Connection available for support of user information (see Table 1/Q.922) within D-, B- or H-channel on the ISDN

user-network interface. The Frame Relay virtual circuit may be either a PVC or an SVC. If a Frame Relay virtual circuit is not established to the AU, the calling TE/X.25 DTE+TA uses the procedures specified in 10.2.3.1.1 below before setting up the X.25 virtual call.

NOTE – If a Frame Relay PVC is established between the calling TE/X.25 DTE+TA and the AU, then X.25 PVCs as well as X.25 virtual calls may be established between the calling TE/X.25 DTE+TA and remote DTEs.

10.2.3.1.1 Outgoing Frame Relay Switched Virtual Circuit

The calling TE/X.25 DTE+TA uses the following procedures:

- 1) The procedures specified in 5.1.2/Q.933 for the Frame Relay connection setup. In the Q.933 SETUP message sent to the AU by the calling TE/X.25 DTE+TA:
 - i) The Called Party Address information element contains the address of the AU.
 - ii) The Bearer Capability information element shall be encoded as follows:
 - information transfer capability set to “unrestricted digital information”;
 - transfer mode set to “frame mode”;
 - user information Layer 2 protocol set to “core aspects of frame mode”.
 - iii) The Low Layer Compatibility information element may be included to pass compatibility information from the calling TE/X.25 DTE+TA to the AU. It is encoded as specified in 10.2.2.2.1 above.
- 2) The procedures specified for Case B in 5.1.3.1/Q.933 for channel negotiation.
- 3) The procedures specified for Case B in 5.1.3.2/Q.933 for Data Link Connection negotiation.
- 4) The procedures specified in 5.1.3.3.2/Q.933 to request a certain QOS.

Upon receipt of a Q.933 SETUP message on the Service Access Point Identifier (SAPI) = 0 of the D-channel, the AU follows the procedures specified in 5.1.3.3.2/Q.933 for parameter negotiation.

10.2.3.1.2 Outgoing X.25 Virtual Call

The X.25 PLP procedures specified in Recommendation X.25 apply.

NOTE – A logical channel number is unique within a Data Link Connection.

The encapsulation procedure of LAPB Frames in Q.922 core frames is specified in 10.2.2.1.2 above (see Figure 10-2).

10.2.3.2 Incoming call

The AU delivers an incoming X.25 virtual call over an established Frame Relay virtual circuit to the called TE/X.25 DTE+TA. If more than one Frame Relay virtual circuit is established to the called TE/X.25 DTE+TA, the AU selects one of these Frame Relay virtual circuits to deliver the incoming X.25 virtual call. The AU may use the occupancy levels of these Frame Relay virtual circuits to perform the selection. If the selection procedure is unsuccessful or if no Frame Relay virtual circuit is established to the called TE/X.25 DTE+TA, the AU initiates the procedures specified below for establishing a Frame Relay SVC before delivering the incoming X.25 virtual call.

10.2.3.2.1 Incoming Frame Relay Switched Virtual Circuit

The network uses the following procedures:

- 1) The procedures specified in 5.2.2/Q.933 for the Frame Relay connection setup. In the Q.933 SETUP message sent by the ISDN to the called TE/X.25 DTE+TA:
 - i) The Called Party Address information element contains the address of the called TE/X.25 DTE+TA.
 - ii) The Bearer Capability information element shall be encoded as specified in 10.2.3.1.1 above.

- iii) The Low Layer Compatibility information element is included, as received from the AU, to pass compatibility information from the AU to the called TE/X.25 DTE+TA. It is encoded as specified in 10.2.3.1.1 above.
 - iv) The characteristics of the Frame Relay SVC may be determined from subscription time agreements information.
 - If the called TE/X.25 DTE+TA is administratively registered with the Administration of the network providing the PSDTS and is successfully identified to the AU, the subparameters of the Link Layer Core Parameter information element in the Q.933 SETUP message sent by the PSPDN AU to the called TE/X.25 DTE+TA are set to the TE/X.25 DTE+TA specific values determined at subscription time.
 - If the called TE/X.25 DTE+TA is not registered or is registered but is not successfully identified to the AU, the subparameters of the Link Layer Core Parameter information element in the Q.933 SETUP message sent by the AU to the called TE/X.25 DTE+TA are set to default values determined by the PSPDN.
- 2) The procedures specified in 5.2.3.1.2/Q.933 for channel selection through call offering.
 - 3) The procedures specified for Case B in 5.2.3.2/Q.933 for Data Link Connection negotiation.

Upon receipt of a Q.933 SETUP message on SAPI = 0 of the D-channel, the called TE/X.25 DTE+TA follows the procedures specified in 5.2.3.3/Q.933 for parameter negotiation.

10.2.3.2.2 Incoming X.25 Virtual Call

The X.25 PLP procedures specified in Recommendation X.25 apply.

NOTE – A Logical channel number is unique within a Data Link Connection.

The encapsulation procedure of LAPB Frames in Q.922 core frames is specified in 10.2.2.1.2 above. The reverse procedure of this encapsulation procedure is specified in 10.2.2.2.2 above. See Figure 10-2.

10.2.4 Frame Relay Switched Virtual Circuit Access Collision

For both Case A and Case B, the access collision procedures specified in 5.6/Q.933 apply.

10.2.5 Frame Relay Switched Virtual Circuit Clearing

10.2.5.1 Clearing initiated by the TE/X.25 DTE+TA

For both Case A and Case B, the TE/X.25 DTE+TA follows the procedures specified in 5.4.3/Q.933 to clear a Frame Relay SVC.

For Case A, the underlying permanent circuit-switched B- or H-channel access connection cannot be cleared by the TE/X.25 DTE+TA using Q.931 clearing procedures. It is cleared by procedures (e.g. administrative, management procedures) which are beyond the scope of this Recommendation.

10.2.5.2 Clearing initiated by the ISDN

For both Case A and Case B, the ISDN follows the procedures specified in 5.4.3/Q.933 to clear a Frame Relay switched virtual call.

For Case A, the underlying permanent circuit-switched B- or H-channel access connection cannot be cleared by the ISDN using Q.931 clearing procedures. It is cleared by procedures (e.g. administrative, management procedures) which are beyond the scope of this Recommendation.

10.2.6 Restart procedures

For both Case A and Case B, the Restart procedures specified in 5.5.1/Q.933 apply.

For Case A and as specified in 5.5.1/Q.933, the Restart procedures do not apply to the underlying permanent circuit-switched B- or H-channel access connection. Therefore the Restart procedures do not affect Frame Relay PVCs and/or SVCs established over a permanent circuit-switched B- and/or H-channel access connection.

For Case B, the Restart procedures do not apply to permanent B- and/or H-channel access connections. Therefore the Restart procedures do not affect Frame Relay PVCs and/or SVCs established over permanent B- and/or H-channel access connections.

10.2.7 Handling of error conditions

For both Case A and Case B, the procedures for handling of error conditions specified in 5.7/Q.933 apply.

In addition, the following rules apply in order of decreasing probability for determining the appropriate cause to be used:

- 1) For Case B, if a Q.933/Q.931 clearing message is received by the ISDN to clear a demand B- or H-channel access connection while Frame Relay SVCs still exist on the B- or H-channel, the AU clears the corresponding X.25 virtual call(s) with cause #17 "remote procedure error" and diagnostic code #64 "call setup, call clearing, or registration problem".
- 2) For both Case A and Case B, if a Q.933 clearing message is received from the ISDN by the AU while X.25 virtual call(s) still exist, the AU clears the X.25 virtual call(s) with cause #17 "remote procedure error" and diagnostic code #64 "call setup, call clearing, or registration problem."
- 3) For Case B, if a Q.933/Q.931 RESTART message is received by the ISDN and a demand B- or H-channel is released as a result while Frame Relay SVCs still exist on the B- or H-channel, the AU releases all the Frame Relay SVCs on that B- or H-channel access connection. The AU also clears the corresponding X.25 virtual call(s) with cause #9 "out of order" and diagnostic code #0 "no additional information".
- 4) For both Case A and Case B if the establishment of a Frame Relay SVC that is triggered by an incoming X.25 virtual call is rejected by the called TE/X.25 DTE+TA using Q.933 messages on the Data Link connection identified by DLCI = 0, the AU clears the incoming X.25 virtual call using an appropriate cause from Table 11-5/X.31.

NOTE 1 – In Table 11-5/X.31, Q.931 is replaced with Q.933.

- 5) For both Case A and Case B if a condition exists that prevents a Q.933 SETUP message that is triggered by an incoming X.25 virtual call from being delivered to the called TE/X.25 DTE+TA on the Data Link Connection identified by DLCI = 0, the AU clears the incoming X.25 virtual call with a cause that is selected appropriate to the condition from Table 11-5/X.31.
- 6) For both Case A and Case B if a Q.933 SETUP message is sent as a result of an incoming X.25 virtual call on a Data Link Connection identified by DLCI = 0 to the called TE/X.25 DTE+TA and no response is received prior to the second expiry of Timer T303, rule 5) above applies.
- 7) For both Case A and Case B if a Q.933 SETUP message is sent as a result of an incoming X.25 virtual call on a Data Link Connection identified by DLCI = 0 to the called TE/X.25 DTE+TA and a response is received which results in the clearing of the Frame Relay SVC, the AU clears the incoming X.25 virtual call using the appropriate cause from Table 11-5/X.31 relative to the cause sent in the clearing message.
- 8) For both Case A and Case B if an X.25 clear request packet is received by the AU via its network prior to the delivery of the Q.933 SETUP message to the called TE/X.25 DTE+TA (premature clearing), a *clear confirmation packet* is sent to the calling DTE and the Frame Relay SVC, when and if established. In the Q.933 clearing message, the AU uses the appropriate cause as described in Table 11-6/X.31.

NOTE 2 – In Table 11-6/X.31, Q.931 is replaced with Q.933.

11 Terminal Adaptor functionalities

11.1 General

Terminal Adaptor (TA) functions are needed to support the access of X.25 DTEs at the reference points of the user-network interface to an FRPDN or an ISDN (see Figure 11-1).

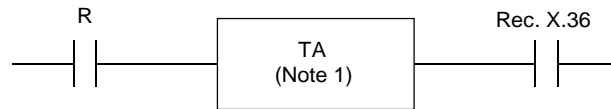

a) TA for access to an FRPDN

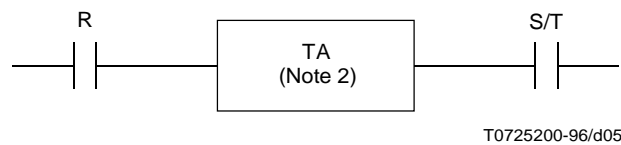

b) TA for access to an ISDN-FR

NOTES

- 1 The TA functionality may reside in the FRPDN.
- 2 The TA functionality may reside in the ISDN-FR.

FIGURE 11-1/X.33

Reference configuration for TA

NOTE – A TA function supports only one X.25 DTE (simple or complex, e.g. LAN-gateway) at Reference point R. In case of Figure 11-1 a), only one TA function is attached to the X.36 interface. In case of Figure 11-1 b), only one TA function is attached to the B-channel at the S/T reference point but more than one TA function may simultaneously share the D-channel, each TA function using a separate LAPD link.

The main functionalities which are provided by the TA are the following:

- Rate adaptation.
- Mapping of signalling information and procedures between the X.36 reference point or the S/T reference point and the R reference point.
- Synchronization.

In the following, these main functionalities are described for the different types of access.

The procedures at the reference points of the user-network interface for an FRPDN or an ISDN-FR are described in clause 10.

11.2 Access to PSDTS via an FRPDN

11.2.1 Physical interfaces

The physical interfaces supported at the R reference point are:

- X.21 Interfaces defined in 1.1/X.25.
- X.21 *bis* Interfaces defined in 1.2/X.25.
- V-Series Interfaces defined in 1.3/X.25.
- Interfaces defined in Recommendation X.32.

The physical interfaces supported at the X.36 reference point are:

- X.21 Interfaces defined in 6.1/X.36.
- X.21 *bis* Interfaces defined in 6.2/X.36.
- V-Series Interfaces defined in 6.3/X.36.
- G-Series Interfaces defined in 6.4/X.36.
- I-Series Interfaces defined in 6.5/X.36.

11.2.1.1 Rate adaptation

Packet mode terminals may operate at the R reference point at data signalling rates which are lower than the data signalling rates at the X.36 reference point.

Flag stuffing is the method for adapting the data rates at the R reference point to the data rates at the X.36 reference point. The rate adaptation is inherent to the interframe fill mechanism which uses flag sequence.

11.2.2 Encapsulation of LAPB frames into X.36 frames

TA provides the encapsulation of LAPB frames into X.36 frames. This encapsulation function which is in accordance with Recommendation I.555 is described in 10.1.2.2.

11.2.3 Signalling

This subclause defines the functionalities to be supported by the TA to establish, maintain and release a Frame Relay virtual circuit to the AU. The TA functionalities may depend on the implementation of X.25 procedures in the DTE. Two X.25 implementation cases are identified:

Case 1: X.25 DTE implementations are capable to disconnect at the physical layer of the R reference point when no virtual circuits exist. For these implementations, the TA will be capable to act only on Layer 1 at the R reference point.

Case 2: X.25 implementations are not capable to disconnect at the physical layer of the R reference point when no virtual circuits exist. The TA may use any combination of the following criteria to automatically initiate the procedures to establish a Frame Relay SVC to the AU:

- TA powers on;
- Availability of the physical layer and/or upper layers at the R reference point (DTE/TA interface);
- Reception of packets at the R reference point (DTE/TA interface).

11.2.3.1 Outgoing call

To provide a Frame Relay virtual circuit to the AU, the TA shall provide:

- a method to indicate that the TA should start the Frame Relay virtual circuit establishment procedure at the X.36 reference point. The available options are described in 11.2.3.1.1.
- a method to transfer address information to the TA which is needed by the Frame Relay virtual circuit establishment procedure. The available options are described in 11.2.3.1.2.

11.2.3.1.1 Conditions for initiating Frame Relay Virtual Circuit Establishment

The conditions which may cause the TA to attempt to establish a Frame Relay virtual circuit are categorized by the following two cases:

- a) Frame Relay PVC.

In this case, the Frame Relay virtual circuit is always available. No TA functionality is required to initiate the establishment of the Frame Relay virtual circuit.

- b) Frame Relay virtual circuit establishment is initiated by actions at the R reference point (DTE/TA interface).

Two conditions are possible. See Table 11-1.

b1) *Hot-line access at the R reference point*

In case of hot-line access at the R reference point, the detection of the following appropriate interface conditions shall cause the TA to establish a Frame Relay virtual circuit to the PSPDN or the ISDN providing PSDTS.

- i) For X.25 layer 1 interface – a transition from OFF to ON on the control lead (in case of X.21 leased circuit procedures) or circuit 108 (in case of X.21 *bis* or V-Series interface procedures).
- ii) For X.21 interfaces – direct call signal (C = ON). The DTE will wait for I = ON before starting transmission.
- iii) For X.21 *bis* interfaces – direct call signal (circuit 108 = ON). The DTE will wait for circuit 107 = ON before starting transmission.
- iv) For V.25 interfaces – direct call signal (circuit 108 = ON). The DTE will wait for circuit 107 = ON before starting transmission.

b2) *Full circuit switched selection access*

Full circuit-switched selection procedure (Recommendation X.21, X.21 *bis* or V.25 *bis*) may be used at the DTE/TA interface to request the establishment of the Frame Relay virtual circuit to an FH. The TA will establish the Frame Relay virtual circuit in accordance with the procedures described in clause 10. The address provided may be used to identify the PSPDN or the ISDN-PSDTS port and full X.25 procedures must be used following the establishment of the Frame Relay virtual circuit to identify the called packet mode DTE.

In case of full circuit-switched selection, the following operating modes of Recommendation X.21, X.21 *bis* and V.25 *bis* at the DTE/TA interface shall cause the TA to establish the Frame Relay virtual circuit to the PSPDN or the ISDN providing PSDTS.

- i) For X.21 circuit-switched interfaces – X.21 call control phase.
- ii) For X.21 *bis* circuit-switched interfaces – use of X.21 *bis* automatic address call facility.
- iii) For V.25 *bis* circuit-switched interfaces – V.25 *bis* addressed call mode.

NOTE – The user may cause the TA to attempt to establish a Frame relay virtual circuit by manual actions (e.g. by pressing a button) at the human/machine interface of the TA. Subsequently the TA may emulate the incoming call towards the DTE.

11.2.3.1.2 Options for transferring the address of the PSPDN or ISDN-PSDTS port to the TA

Four options exist to handle address information of the PSPDN or the ISDN-PSDTS port at the TA:

- a) Frame Relay PVC at the X.36 reference point.

In this case, the TA has no need for address information, i.e. no functionality is required in the TA to obtain an address.

- b) The address is conveyed across the R reference point.

In this case, the circuit-switched procedures described in 11.2.3.1.1 b2) are required.

- c) The address is conveyed across the human/machine interface of the TA.

Manual procedures are used (e.g. by means of a keypad) at the human/machine interface of the TA. The address may be provided each time a Frame Relay connection is requested. Alternatively, the address may be stored at the TA (e.g. in the case of hot-line operation at the R reference point).

- d) The address is downloaded by the network via the X.36 reference point. The need for this option is for further study.

NOTE – The address information may be for example a full E.164 address which is used by hot-line access procedures at the X.36 reference point, or an abbreviated address which is interpreted by the TA and expanded to a full E.164 address using pre-recorded information in the TA.

TABLE 11-1/X.33

**DTE/TA Layer 1 Specification and Procedures
to Initiate the Establishment of a Frame Relay Virtual Circuit**

Condition	DTE/TA layer 1 specification		Events at the R reference point	Procedures according to:
Hot-line access	Rec. X.25	X.21 leased circuit	DTE sets C = ON	1.1/X.25
		Rec. X.21 <i>bis</i>	DTE sets circuit 108 = ON	1.2/X.25
		V-Series interfaces	DTE sets circuit 108 = ON	1.3/X.25
	X.21 circuit-switched		DTE signals direct call	4.4/X.21
	X.21 <i>bis</i> direct call		DTE signals direct call	2.3.1/X.21 <i>bis</i>
	V.25 <i>bis</i> direct call		DTE uses direct call mode (Note)	Clause 5/V.25 <i>bis</i>
Full circuit-switched access	X.21 addressed call		DTE enters call control phase	Clause 4/X.21
	X.21 <i>bis</i> addressed call		DTE performs automatic address call	2.3.2 iii)/X.21 <i>bis</i>
	V.25 <i>bis</i> addressed call		DTE uses address call mode	Clause 4/V.25 <i>bis</i>
NOTE – The difference between the V.25 <i>bis</i> direct call mode and operation according to 1.3/X.25 (V-Series interfaces) is for further study.				

11.2.3.1.3 Procedures for mapping

The list of supported combinations and the appropriate procedures are given in Table 11-2.

Following the establishment of the Frame Relay virtual circuit, the TA should place the R reference point in the appropriate condition for data transfer at layer 1.

11.2.3.1.4 Mapping of the X.36 messages

The procedures between the TA and the AU are specified in 10.1.

11.2.3.1.5 X.25 procedures

In the data transfer phase, the TA may be transparent to layer 2 and layer 3 of the X.25 procedures. However, some realizations of X.25 terminals may require full or partial termination of layer 2 within the TA to accommodate existing LAPB establishment procedures.

11.2.3.2 Incoming call

11.2.3.2.1 Incoming Frame Relay Virtual Circuit

The procedures for incoming Frame Relay SVC specified in 10.1.3.1 apply.

TABLE 11-2/X.33

TA Functionality to control the establishment of Frame Relay Virtual Circuit

	TA function		Description of procedures
	Conditions for initiation of the establishment of a Frame Relay virtual circuit (11.2.3.1.1)	Transfer of address information to the TA (11.2.3.1.2)	
1	Condition a)	Option a)	Frame Relay PVC connection. No signalling functions for layer 1 are needed in the TA
2	Condition b1) i)	Option c)	The DTE sets C=ON or circuit 108=ON. When C (or circuit 108) becomes ON and the manual selection has been made at the TA, the TA then initiates the establishment of a Frame Relay connection to provide a connection to the PSPDN or the ISDN-PSDTS. When the Frame Relay connection is completely established at the X.36 reference point, the TA sets I=ON (or circuit 107=ON)
3	Any of conditions b1) ii), iii), iv)	Option c)	When the manual selection has been made at the TA, the TA may emulate an incoming call at the R reference point. If the DTE accepts this incoming call, the TA places the R reference point in the DCE waiting state at layer 1 and then initiates the establishment of a Frame Relay virtual circuit to provide a connection to the PSPDN or the ISDN-PSDTS
	See Note in 11.2.3.1.1	Option c)	When the Frame Relay virtual circuit is successfully established at the X.36 reference point, the TA signals ready for data at the R reference point
4	Any of condition b2)	Option b)	When the DTE has requested the layer 1 connection and provided address information to the TA, the TA initiates the establishment of a Frame Relay virtual circuit. When the Frame Relay connection is completely established at the X.36 reference point the TA signals ready for data, using the appropriate procedure at the R reference point
5	Condition b1)	Option a)	In this case, hot-line access is applied at the R reference point as well as the X.36 reference point. No address information is therefore required by the TA. When the DTE presents the call request, the TA attempts to establish a Frame Relay virtual circuit. When the Frame Relay virtual circuit is successfully set up, the TA signals ready for data at the R reference point

11.2.3.2.2 Actions at the R Reference Point

The TA shall not accept an incoming call from the network unless the R reference point is in one of the following states:

- The ready state for an R reference point conforming to X.21 circuit-switched procedures.

- The ready or send state for an R reference point conforming to X.21 leased circuit procedures.
- Circuits 125 and 108 ON with 107 OFF for an R reference point conforming to X.21 *bis* procedures.

If the R reference point is in (or can be placed in) the appropriate state defined above, the TA shall return a CONNECT message as a response to a previously received SETUP message in accordance with the procedures in 10.1.3.1 and shall place the Frame Relay SVC in the Active state. The TA may also reject the SETUP message by responding with a RELEASE COMPLETE message.

If the R reference point is not and cannot be placed in the appropriate states defined above, then the TA shall respond to the SETUP message in accordance with the negative response to the incoming call procedures defined in clause 10.

The return of a CONNECT message causes the TA to initiate the appropriate procedures according to the physical layer applicable at the R reference point leading to place the R reference point into the appropriate condition for data transfer and to begin transmission using the X.25 PLP procedures over the Frame Relay SVC.

NOTE – The DTE/TA interface shall not be placed in the data transfer state before the Frame Relay connection is successfully set up at the X.36 reference point (see 11.2.4).

11.2.3.2.3 X.25 procedures

In the data transfer phase, the TA is transparent to layer 2 and layer 3 of the X.25 procedures. However some TAs may partially or fully terminate Layer 2 and fully terminate Layer 3.

11.2.3.3 Call clearing

To initiate the clearing of the Frame Relay SVC, it is necessary to detect the clearing of the last X.25 virtual call on the Frame Relay SVC. Three parties can detect the clearing of the Frame Relay connection:

- 1) The DTE: initiating clearing via the R reference point.
- 2) The network (AU): initiating clearing via the X.36 reference point.
- 3) The user: initiating clearing manually via the human/machine interface.

11.2.3.3.1 Initiating of call clearing by the DTE

The conditions at the R reference point which cause the TA to attempt to disconnect the Frame Relay SVC are:

- For X.21 circuit-switched interface – DTE clear request signal.
- For X.21 leased circuit interface – a transition from ON to OFF on the control lead.
- For X.21 *bis* interface – DTE clear request signal (circuit 108) from ON to OFF.

When one of these conditions occurs, the TA will disconnect the internal rate adapting connection between the R reference point and the X.36 reference point (see 11.2.1.1) and will try to disconnect the Frame Relay connection applying the procedures of 10.1.5.1.

11.2.3.3.2 Initiating of call clearing by the network

For the clearing of the Frame Relay SVC, the network applies the procedures of 10.1.5.2. The receipt of a DISCONNECT or RELEASE message shall cause the TA to disconnect the internal rate adapting connection between the R reference point and the X.36 reference point and to take at the R reference point interface the appropriate action as described below:

- For X.21 circuit-switched interface – signal a DCE clear indication.
- For X.21 leased circuit interface – signal a DCE clear indication.
- For X.21 *bis* interface – set circuit 107 OFF.

See Recommendation X.30 for further details.

11.2.3.3.3 Initiating of call clearing by the user

After the manual notification of the clearing of the last virtual call by the user, the TA disconnects the internal connection between the R reference point and the X.36 reference point and applies the procedures of 10.1.5.1 for the clearing of the Frame Relay connection. At the R reference point, the TA takes the appropriate action as described below:

- For X.21 circuit-switched interface – signal a DCE clear indication.
- For X.21 leased circuit interface – signal a DCE clear indication.
- For X.21 *bis* interface – set circuit 107 OFF.

See Recommendation X.30 for further details.

11.2.4 Synchronization

The TA should effect synchronization between the Data Link Connection identified with DLCI = 0 link and other Data Link Connections (DLCs) that may support Frame Relay virtual circuits.

Synchronization between the TA and the AU is provided by the exchange of synchronization pattern. Continuous flag transmission shall be used when flag stuffing rate adaptation is used.

11.3 Access to PSDTS using ISDN-FR

11.3.1 Physical interface

The physical interfaces supported at the R reference point are those defined in clause 1/X.25 and in Recommendation X.32. The physical interfaces supported at the R reference point are those defined in Recommendations I.430 and I.431.

11.3.1.1 Rate adaptation

Rate adaptation can be performed in two ways:

- 1) Packet mode of operation (case B of access via ISDN-FR) by using HDLC interframe flag stuffing.

In this case, packet mode terminals operating at data signalling rates lower than 64 kbit/s at the R reference point can no longer be distinguished by the network from packet mode terminals operating at a data rate of 64 kbit/s at the R reference point.

Therefore, the signalling procedures at the S/T reference point will indicate the data signalling rate of that reference point rather than the user data signalling at the R reference point. In addition, a throughput class may be indicated in the incoming call signalling procedures at the S/T reference point.

It should be noted that the frame handling in the FRPDN or the ISDN will be optimized for DTEs generating HDLC structured traffic at the rates defined in Recommendation I.211. In such networks, flag stuffing is the preferred method for rate adaptation.

- 2) Circuit mode of operation (case A of access via an ISDN-FR) by using the method indicated in Recommendation X.30/I.461.

In this case, the D-channel signalling procedures shall indicate the data signalling rate being used by the DTE connected to the R reference point (this will be lower than 64 kbit/s).

As an alternative to HDLC interframe flag stuffing, this bit rate adaptation method may be supported by some networks in case of access to PSPDN services.

NOTE – The use of the V-Series specifications is for further study.

11.3.2 Encapsulation of LAPB frames into Q.922 core frames

TA provides the encapsulation of LAPB frames into Q.922 core frames. This encapsulation function which is in accordance with Recommendation I.555 is described in 10.2.2.1.2.

11.3.3 Signalling

See 11.2.3.

11.3.3.1 Outgoing call

The requirements specified in 11.2.3.1 apply by replacing “X.36 reference point” with “S/T reference point”, “subclause 11.2.3.1.1” with “subclause 11.3.3.1.1” and “subclause 11.2.3.1.2” with “subclause 11.3.3.1.2.”

11.3.3.1.1 Conditions for initiating Frame Relay Virtual Circuit Establishment

The conditions specified in 11.2.3.1.1 apply.

11.3.3.1.2 Options for transferring the address of the PSPDN or ISDN-PSDTS port to the TA

The options specified in 11.2.3.1.2 apply by replacing “X.36 reference point” with “S/T reference point.”

11.3.3.1.3 Procedures for mapping

The procedures specified in 11.2.3.1.3 apply by replacing “X.36 reference point” with “S/T reference point”, “subclause 11.2.3.1.1” with “subclause 11.3.3.1.1” and “subclause 11.2.3.1.2” with “subclause 11.3.3.1.2.”

11.3.3.1.4 Mapping of the Q.933 messages

The procedures between the TA and the AU are specified in 10.2.

11.3.3.1.5 X.25 procedures

The procedures specified in 11.2.3.1.5 apply.

11.3.3.2 Incoming call

11.3.3.2.1 Incoming Frame Relay Virtual Circuit

For Case A procedures, the procedures for incoming Frame Relay SVC specified in 10.2.2.2.1 apply. For Case B procedures, the procedures for incoming Frame Relay SVC specified in 10.2.3.2.1 apply.

11.3.3.2.2 Actions at the R Reference Point

For Case A procedures, The procedures specified in 11.2.3.2.2 apply by replacing “subclause 10.1.3.1” with “subclause 10.2.2.2.1 for Case A procedures” and with “subclause 10.2.3.2.1 for Case B procedures.”

11.3.3.2.3 X.25 procedures

The procedures specified in 11.2.3.2.3 apply.

11.3.3.3 Call clearing

The procedures specified in 11.2.3.3 apply by replacing “X.36 reference point” with “S/T reference point.”

11.3.3.3.1 Initiating of call clearing by the DTE

The conditions specified in 11.2.3.3.1 apply by replacing “X.36 reference point” with “S/T reference point” and “subclause 10.1.5.1” with “subclause 10.2.5.1.”

11.3.3.3.2 Initiating of call clearing by the network

The procedures specified in 11.2.3.3.2 apply by replacing “X.36 reference point” with “S/T reference point” and “subclause 10.1.5.2” with “subclause 10.2.5.2.”

11.2.3.3.3 Initiating of call clearing by the user

The procedures specified in 11.2.3.3.3 apply by replacing “X.36 reference point” with “S/T reference point” and “subclause 10.1.5.1” with “subclause 10.2.5.1.”

11.3.4 Synchronization

The procedures specified in 11.2.4 apply.

ITU-T RECOMMENDATIONS SERIES

- Series A Organization of the work of the ITU-T
- Series B Means of expression
- Series C General telecommunication statistics
- Series D General tariff principles
- Series E Telephone network and ISDN
- Series F Non-telephone telecommunication services
- Series G Transmission systems and media
- Series H Transmission of non-telephone signals
- Series I Integrated services digital network
- Series J Transmission of sound-programme and television signals
- Series K Protection against interference
- Series L Construction, installation and protection of cables and other elements of outside plant
- Series M Maintenance: international transmission systems, telephone circuits, telegraphy, facsimile and leased circuits
- Series N Maintenance: international sound-programme and television transmission circuits
- Series O Specifications of measuring equipment
- Series P Telephone transmission quality
- Series Q Switching and signalling
- Series R Telegraph transmission
- Series S Telegraph services terminal equipment
- Series T Terminal equipments and protocols for telematic services
- Series U Telegraph switching
- Series V Data communication over the telephone network
- Series X Data networks and open system communication**
- Series Z Programming languages