



INTERNATIONAL TELECOMMUNICATION UNION

**ITU-T**

TELECOMMUNICATION  
STANDARDIZATION SECTOR  
OF ITU

**V.252**

(02/98)

SERIES V: DATA COMMUNICATION OVER THE  
TELEPHONE NETWORK

Control procedures

---

**Procedure for control of V.70 and H.324  
terminals by a DTE**

ITU-T Recommendation V.252

(Previously CCITT Recommendation)

---

ITU-T V-SERIES RECOMMENDATIONS  
DATA COMMUNICATION OVER THE TELEPHONE NETWORK

General	V.1–V.9
Interfaces and voiceband modems	V.10–V.34
Wideband modems	V.35–V.39
Error control	V.40–V.49
Transmission quality and maintenance	V.50–V.59
Simultaneous transmission of data and other signals	V.60–V.99
Interworking with other networks	V.100–V.199
Interface layer specifications for data communication	V.200–V.249
<b>Control procedures</b>	<b>V.250–V.299</b>

*For further details, please refer to ITU-T List of Recommendations.*

## **ITU-T RECOMMENDATION V.252**

### **PROCEDURE FOR CONTROL OF V.70 AND H.324 TERMINALS BY A DTE**

#### **Summary**

This Recommendation describes the operation of the DCE/DTE interface in which either an H.324 entity or a V.70 DSVD entity is implemented in the DCE. The V.70 entity in the DCE comprises at least a V.76 multiplexer and the V.75 control unit. The H.324 entity in the DCE comprises at least an H.223 multiplexer and the H.245 control unit for H.324. Audio and video transducers and codecs, if present, are implemented in the DCE or in devices attached directly to the DCE. Commands and indications defined in this Recommendation are valid in FCLASS=17.0 or FCLASS=18.0. The availability of Class 17.0 in a DCE indicates that the DCE is capable of supporting the control functions of a V.70 DSVD device. The availability of Class 18.0 in a DCE indicates that the DCE is capable of supporting the control functions of an H.324 terminal.

#### **Source**

ITU-T Recommendation V.252 was prepared by ITU-T Study Group 16 (1997-2000) and was approved under the WTSC Resolution No. 1 procedure on the 6th of February 1998.

## FOREWORD

ITU (International Telecommunication Union) is the United Nations Specialized Agency in the field of telecommunications. The ITU Telecommunication Standardization Sector (ITU-T) is a permanent organ of the ITU. The ITU-T is responsible for studying technical, operating and tariff questions and issuing Recommendations on them with a view to standardizing telecommunications on a worldwide basis.

The World Telecommunication Standardization Conference (WTSC), which meets every four years, establishes the topics for study by the ITU-T Study Groups which, in their turn, produce Recommendations on these topics.

The approval of Recommendations by the Members of the ITU-T is covered by the procedure laid down in WTSC Resolution No. 1.

In some areas of information technology which fall within ITU-T's purview, the necessary standards are prepared on a collaborative basis with ISO and IEC.

## NOTE

In this Recommendation, the expression "Administration" is used for conciseness to indicate both a telecommunication administration and a recognized operating agency.

## INTELLECTUAL PROPERTY RIGHTS

The ITU draws attention to the possibility that the practice or implementation of this Recommendation may involve the use of a claimed Intellectual Property Right. The ITU takes no position concerning the evidence, validity or applicability of claimed Intellectual Property Rights, whether asserted by ITU members or others outside of the Recommendation development process.

As of the date of approval of this Recommendation, the ITU had not received notice of intellectual property, protected by patents, which may be required to implement this Recommendation. However, implementors are cautioned that this may not represent the latest information and are therefore strongly urged to consult the TSB patent database.

ITU 1998

All rights reserved. No part of this publication may be reproduced or utilized in any form or by any means, electronic or mechanical, including photocopying and microfilm, without permission in writing from the ITU.

## CONTENTS

		<b>Page</b>
1	Scope.....	1
2	Control model .....	1
2.1	Device codes .....	2
3	Commands .....	3
3.1	Terminal configuration, +STC.....	3
3.2	Close logical channel, +STH .....	4
3.3	Data configuration, +SDC .....	5
3.4	Audio transmit configuration, +SAC.....	7
3.5	Audio receive mode +SAM .....	8
3.6	Video transmit configuration +SVC (Class 18 only).....	10
3.7	Video receive mode +SVM (Class 18 only).....	11
3.8	Data indication reporting, +SDR .....	12
3.9	Audio indication reporting, +SARR.....	13
3.10	Video indication reporting, +SVRR (Class 18 only).....	13
3.11	Capabilities indication reporting, +SCRR .....	14
4	Additional commands .....	14
4.1	Set audio code, +VAC .....	14
4.2	Receive gain selection, +VGR.....	15
4.3	Transmit gain selection, +VGT.....	16
4.4	Beep tone duration timer, +VTD .....	17
4.5	DTMF and tone generation, +VTS .....	17
4.6	Ring local phone, +VRL.....	19
4.7	Speakerphone ON/OFF, +VSP .....	20
4.8	Train acoustic echo-canceller, +VTA.....	20
4.9	Train hybrid echo-canceller, +VTH.....	21
4.10	Speakerphone configuration, +VDX.....	21
4.11	Phone hookswitch status, +VPH.....	22
4.12	Telephony port hook control, +VHC .....	22
5	Indications.....	23
5.1	Remote terminal capabilities indications.....	23
5.1.1	Remote terminal capability table entry indications, +SRCV, +SRCA, +SRCD.....	24
5.1.2	Remote terminal simultaneous capability indication, +SRSC.....	24

	<b>Page</b>
5.2 Data channel indication, +SDI.....	24
5.3 Audio receive channel indication, +SAR.....	25
5.4 Audio transmit channel indication, +SAT .....	25
5.5 Video receive channel indication, +SVR (Class 18 only) .....	25
5.6 Video transmit channel indication, +SVT (Class 18 only) .....	25
6 Additional indications.....	26
6.1 Audio code report, +VACR .....	26
6.2 Caller ID report, +VCIDR .....	26
6.3 DID report, +VDIDR .....	26
6.4 Simple telephony event report, +VTER.....	26
7 In-band indications and commands .....	27
7.1 In-band indications.....	27
7.2 In-band commands.....	27
7.3 Remote DCE in-band commands and indications .....	28

## Recommendation V.252

### PROCEDURE FOR CONTROL OF V.70 AND H.324 TERMINALS BY A DTE

(Geneva, 1998)

#### 1 Scope

This Recommendation describes the operation of the DCE/DTE interface in which either an H.324 entity or a V.70 DSVD entity is implemented in the DCE. The V.70 entity in the DCE comprises at least a V.76 multiplexer and the V.75 control unit. The H.324 entity in the DCE comprises at least an H.223 multiplexer and the H.245 control unit for H.324. Audio and video transducers and codecs, if present, are implemented in the DCE or in devices attached directly to the DCE. In the case of an H.324 DCE, if one or more data channels are present, one of them is assumed to terminate in the DTE. Commands and indications defined in this Recommendation are valid in FCLASS=17.0 and/or FCLASS=18.0. The availability of Class 17.0 in a DCE indicates that the DCE is capable of supporting the V.76 multiplexing and V.75 control functions of a V.70 DSVD device. The availability of Class 18.0 in a DCE indicates that the DCE is capable of supporting the H.223 multiplexing and H.245 control functions of an H.324 terminal.

#### 2 Control model

Figure 1 is a block diagram of a typical Class 17 system:

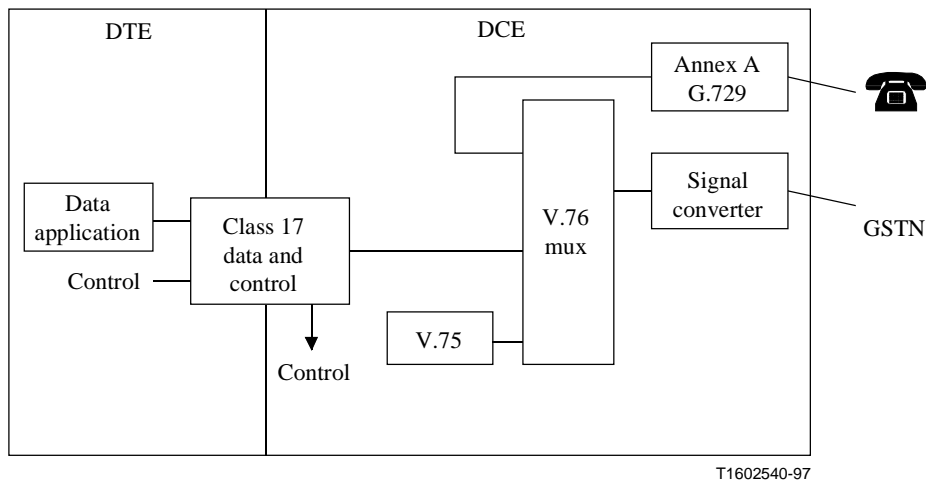
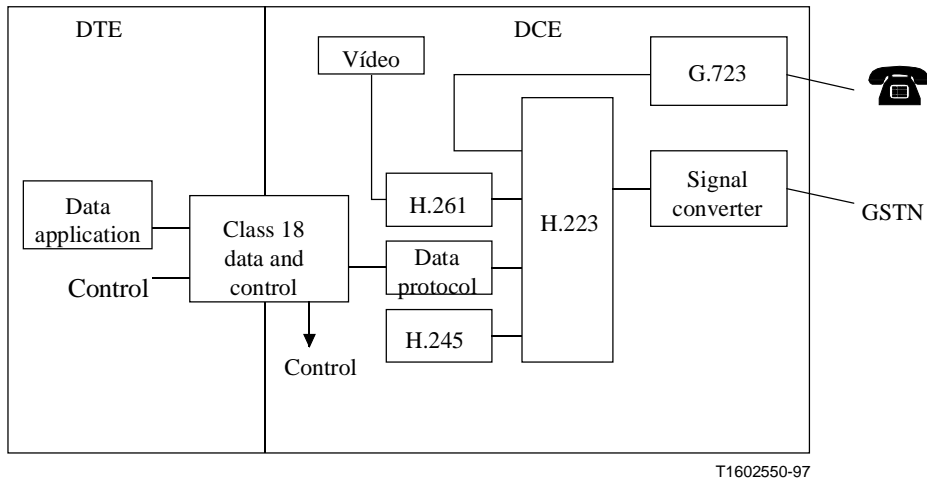

Figure 1/V.252 – V.70 DSVD DCE

Figure 2 is a block diagram of a typical Class 18 system:



**Figure 2/V.252 – H.324 terminal with "data port"**

The basic model of V.70/H.324 DCE control is that there are a number of named "devices" which are capable of sourcing or sinking audio, video, or data streams. These logical devices include physical media devices such as cameras, displays, microphones and speakers. All logical devices are assigned a one - or two-character device code.

The DTE can control device characteristics and which devices are active on a given connection. The assignment of devices to specific V.76 or H.223 multiplexer channels, however, is the responsibility of the V.75 or H.245 control entity, respectively, in the DCE.

## 2.1 Device codes

Each logical device is assigned a one - or two-character "device code", as follows:

**Table 1/V.252 – Device codes**

Device code	Logical device
L	Local telephone port (see Note 1)
M0	Internal microphone
M1	External microphone
M <sub>n</sub>	<i>n</i> = 2..255 Additional microphones
S0	Internal speaker
S1	External speaker
S <sub>n</sub>	<i>n</i> = 2..255 Additional loudspeakers
H0	External handset/headset
H <sub>n</sub>	<i>n</i> = 1..255 Additional handsets/headsets
C0	Internal camera
C1	External camera
C <sub>n</sub>	<i>n</i> = 2..255 Additional cameras



**Table 1/V.252 – Device codes (end)**

Device code	Logical device
V0	Internal video display device
V1	External video display device
V $n$	$n = 2..255$ Additional video displays
<p>NOTE 1 – It may be possible in some DCE, by hardware strapping or other means outside the scope of this Recommendation, to configure the "L" local telephone port device to interconnect to either a local telephone device and appear as a PSTN telephone line (which would require the DCE to provide loop voltage, etc.) or to interconnect to a second PSTN telephone line and appear as a telephone device (which would require the DCE to provide loop supervision, ring detect, etc.).</p> <p>NOTE 2 – It is intended that the device codes for non-video devices be identical to those defined in other functional classes, such as in Class 8.0.</p> <p>NOTE 3 – Support for "L" and "R" suffixes for left and right identification can be added once they are supported by H.245 and V.75.</p>	

In addition, data channels are given a numeric identification label, with channel 0 being the "data port" channel connected to the DTE. Channel existence and source/sink device assignment may be performed prior to a connection, either by default or by configuration command. In this case, the DCE shall automatically negotiate such operation with the remote end at the commencement of a communication session. Alternately, channels and devices may be created and/or destroyed dynamically during a connection using the appropriate commands.

### 3 Commands

#### 3.1 Terminal configuration, +STC

##### Parameter

+STC= "<string of device codes>"

##### Description

This parameter is used to select the audio, video (for Class 18), and data devices that are to be used in a connection. If supported by the remote terminal, the specified devices shall be used. If issued during a connection, this is an action command that changes the configuration of the connection; in this case, the DCE shall return ERROR if the new configuration is not supported by the remote terminal (e.g., if an OpenLogicalChannelReject response is received from the remote terminal).

Note also that, prior to the ERROR final result code, the DCE may issue information text as to the reason for the failure. This information text shall take the form of +STC: FAIL <err\_num>, where the <err\_num> parameter has the following value assignments:

<err_num>	Definition
0	Syntax error
1	XID frame rejection
2	OpenLogicalChannel rejection

If issued during a connection, this shall cause the relevant channels to be established or released. Depending on the channel configuration and specific DCE implementation, this may be preceded by capability exchanges between the DCEs. If the channel indications defined in clause 5 are enabled, they are issued when the channels are opened or closed.

### **Defined values**

A valid parameter value consists of a string, bounded by double quotes, of device codes as defined in 2.1, with the device codes separated by commas.

### **Default value**

Default configuration is determined by the manufacturer.

### **Read syntax**

+STC?

In command state (i.e., not during a connection), the DCE shall return the current parameter setting, e.g.:

+STC: "L,C0,V0,0"

for a DCE configured for audio on the local telephone, transmit video from the internal camera, receive video to the internal display, and a data channel to the DTE.

In on-line command state, the DCE shall return the current configuration in use on the connection.

### **Test syntax**

+STC=?

The DCE shall return information text indicating supported configurations. Lists of alternative devices which cannot be supported simultaneously may be enclosed in parentheses, e.g.:

+STC: "(L,M0,M1),(L,S0,S1),(C0,C1),(V0,V1),0"

indicates the ability to support one audio transmit channel (from either local phone, or internal or external microphones), one audio receive channel, one video channel in each direction, and a data channel to the DTE. As another example, a DCE capable of supporting two duplex audio channel pairs, with one pair to the local phone, would return:

+STC: "L,(M0,M1),(S0,S1),(C0,C1),(V0,V1),0"

More complex dependencies may be indicated by the DCE by returning multiple lines.

## **3.2 Close logical channel, +STH**

### **Parameter**

+STH="<string of device codes>"

### **Description**

This action command is issued during a connection to cause the specified channel(s) to be released.

### **Defined values**

A valid parameter value consists of a string, bounded by double quotes, of device codes as defined in 2.1, with the device codes separated by commas.

### **Test syntax**

+STH=?



00004 CIF  
 00008 ccir601Seq  
 00010 ccir601Prog  
 00020 hdtvSeq  
 00040 hdtvProg  
 00080 g3FacsMh200x100  
 00100 g3FacsMH200x200  
 00200 g4FacsMMR200x100  
 00400 g4FacsMMR200x200  
 00800 jbig200x200Seq  
 01000 jbig200x200Progr  
 02000 jbig300x300Seq  
 04000 jbig300x300Progr  
 08000 digPhotoLow  
 10000 digPhotoMedSeq  
 20000 digPhotoMedProg  
 40000 digPhotoHighSeq  
 80000 digPhotoHighProg

<uih> Support for V.76 UIH frames for this channel:  
 0 Non-supported  
 1 Supported

<winsize> V.76 window size for this channel (1..127)

<recovery> V.76 error recovery for this channel:  
 0 None  
 1 Non-selective reject  
 2 Selective reject  
 3 Multiple selective reject

<crc> CRC type used by V.76 multiplex for this channel:  
 0 8-bit  
 1 16-bit  
 2 32-bit

<n401> V.76 N401 value for this channel (1..127)

<V42bislen> V.42 *bis* maximum string length for this V.76 channel

<V42bissiz> V.42 *bis* maximum dictionary size for this V.76 channel

### Default values

In Class 17, for data channel 0, the default application shall be user data, and the default protocol shall be Asynchronous ERM (if available), or Asynchronous UNERM. In Class 18, for data channel 0, the default application shall be user data, and the default protocol shall be LAPM (if available), or Buffered V.14. For additional data channels, default values are manufacturer defined.

### Read syntax

+SDC?

The DCE shall transmit the current local, preconfigured settings for each existing data channel, one channel per line, e.g. in Class 18 operation:

+SDC: 0, 3, 2

+SDC: 1, 6, 2

for a DCE with one LAPM data channel connected to the DTE, and a second channel running H.224 for H.281 camera control.

### Test syntax

+SDC=?

The DCE shall transmit the range of capabilities for each possible data channel, one channel per line, e.g.:

+SDC: 0,(0-7),(0-4),,(FFFFFF),(0-1),(1-127),(0-3),(0-2),  
(1-127),(0-64),(0-2048)

for a DCE capable of implementing one data channel with all the options.

NOTE – A DCE response enumerating multiple data channels does not imply that these capabilities are available simultaneously.

## 3.4 Audio transmit configuration, +SAC

### Parameter

+SAC=<acode>,<std>[,<arate>[,<silsup>[,<blockf>[,<susresume>[,<audioh>[,<Suspend wAd>[,<crc>[,<n401>]]]]]]]]

### Description

This parameter sets the preferred operating mode for an outgoing audio channel from audio device <acode>. If the remote terminal is incapable of operating at the preferred mode, audio channel operation may take place in another mode within the DCE's capability.

This command serves to configure the DCE transmit capabilities, and may be issued prior to a connection to change the DCE from the default configuration, or during a connection prior to a +STC command. The subsequent +STC may then trigger a capabilities exchange.

### Defined values

<acode>	This is a supported audio device code as defined in 2.1.
<std>	This selects or describes the audio encoding standard for the outgoing channel: 0 Non-standard encoding 1-3 Reserved 4 G.723.1 5 G.728 6 G.729 7 Annex A/G.729 8-255 Reserved for future standardization
<arate>	This selects different bit rates for the G.723.1 coder. The use of this subparameter with other coders is for further study: 0 Low bit rate 1 High bit rate
<silsup>	This subparameter enables or disables the use of silence suppression with the G.723.1 coder, and in the case of the G.729 and Annex A/G.729 coders, enables or disables the use of Annex B/G.729 silence suppression. The use of this subparameter with other coders is for further study: 0 No silence suppression 1 Silence suppression

<blockf>	Selects audio blocking factor
<susresume>	Select V.76 suspend/resume operation: 0 Disabled 1 Enabled
<audioh>	Select V.75 audio header: 0 Disabled 1 Enabled
<SuspendwAd>	Select V.76 use of address with suspend/resume: 0 Disabled 1 Enabled
<crc>	CRC type used by V.76 multiplex for this channel: 0 8-bit 1 16-bit 2 32-bit
<n401>	V.76 N401 value for this channel (1..127)

### Default values

Default values are manufacturer defined.

### Read syntax

+SAC?

The DCE shall transmit the current local, preconfigured settings for each existing outgoing audio channel, one channel per line, e.g.:

+SAC: L, 4, 0, 0, 1, 0, 1, 0, 0, 7

for a DCE supporting G.723 audio from the local telephone.

### Test syntax

+SAC=?

The DCE shall transmit the range of capabilities for each possible outgoing audio source, one source per line, e.g.:

+SAC: L, (4), (0-1), (1), (0), (1), (0), (0-1), (1-7)

+SAC: M0, (8, 11), (0-1), (1), (0), (1), (0), (0-1), (1-7)

for a DCE capable of implementing G.723 or Annex A/G.729 audio from both the local telephone and the internal microphone.

NOTE – A DCE response enumerating multiple channels does not imply that these capabilities are available simultaneously.

## 3.5 Audio receive mode +SAM

### Parameter

+SAM=<acode>, <pref>, <std>, <arate>, <silsup>

### Description

This parameter selects the audio mode of operation for an incoming channel. Multiple +SAM commands may be entered to define a list of preferred modes for the same <acode>.

This command serves to configure RequestMode H.245 messages sent to the remote terminal transmitter, and is not relevant to V.70 Class 17 operation.

### Defined values

<acode>	This is a supported audio device code as defined in 2.1.
<pref>	This indicates an order of preference for the described mode. Multiple +SAM commands may be entered for the same <acode> device, in which case the preference parameter selects the order in which the V.75 or H.245 entity in the DCE will select modes of operation. The lower the number, the higher the preference. Range is 1..255.
<std>	This selects or describes the audio encoding standard for the outgoing channel: 0 Non-standard encoding 1-3 Reserved 4 G.723.1 5 G.728 6 G.729 7 Annex A/G.729 8-255 Reserved for future standardization
<arate>	This selects different bit rates for the G.723.1 coder. The use of this subparameter with other coders is for further study: 0 Low bit rate 1 High bit rate
<silsup>	This subparameter enables or disables the use of silence suppression with the G.723.1 coder, and in the case of the G.729 and Annex A/G.729 coders, enables or disables the use of Annex B/G.729 silence suppression. The use of this subparameter with other coders is for further study: 0 No silence suppression 1 Silence suppression

### Default values

Default values are manufacturer defined.

### Read syntax

+SAM?

This returns a list of all +SAM commands in effect in the DCE, one per line, with strings of the form:

+SAM: <acode> , <pref> , <std> , <arate> , <silsup>

e.g., for a DCE that prefers G.723.1 on the local telephone but Annex A/G.729 on the external speaker:

+SAM: L , 1 , 4

+SAM: L , 2 , 7

+SAM: S0 , 1 , 7

+SAM: S0 , 2 , 4

### Test syntax

+SAM=?

The DCE shall transmit the range of capabilities for each possible incoming audio sink, one sink per line, e.g.:





<cif16MPI>	This integer selects the Minimum Picture Interval for QCIF16 encoding, with values in the range 1..32. A value of 0 indicates QCIF16 is not supported.
<urv>	When set to one, this boolean subparameter enables the Unrestricted Vector coding option in the encoder. When set to zero, this option in the encoder is disabled.
<arith>	When set to one, this boolean subparameter enables the Arithmetic Coding option in the encoder. When set to zero, this option in the encoder is disabled.
<advpred>	When set to one, this boolean subparameter enables the Advanced Prediction option in the encoder. When set to zero, this option in the encoder is disabled.
<pbframes>	When set to one, this boolean enables the PB Frames option in the encoder. When set to zero, this option in the encoder is disabled.

### Default values

Default values are manufacturer defined.

### Read syntax

+SVC?

The DCE shall transmit the current local, preconfigured settings for each existing outgoing video channel, one channel per line, e.g.:

+SVC: C0,1,2,2,240,1,0

+SVC: C1,2,2,30,216,1,1,2,32,32,1,1,1,1

### Test syntax

+SVC=?

The DCE shall transmit the range of capabilities for each possible outgoing video source, one source per line, e.g.:

+SVC=C0,(1-2),(1-32),(1-32),(144-312)(0-1),(0),(0),(0),(0-1),  
(0-1),(0-1),(0-1)

NOTE – A DCE response enumerating multiple channels does not imply that these capabilities are available simultaneously.

## 3.7 Video receive mode +SVM (Class 18 only)

### Parameter

+SVM=<vcode>,<pref>,<std>,<resol>[,<urv>,<arith>,<advpred>,<pbframes>]

### Description

This parameter selects the video mode of operation for an incoming channel. Multiple +SVM commands may be entered to define a list of preferred modes for the same <vcode>.

This command serves to configure the RequestMode H.245 messages sent to the remote terminal transmitter.

<vcode> This is a supported video device code as defined in 2.1.

<pref> This indicates an order of preference for the described mode. Multiple +SVM commands may be entered for the same <vcode> device, in which case the preference parameter selects the order in which the H.245 entity in the DCE will select modes of operation. The lower the number, the higher the preference. Range is 1..255.

<std>	This subparameter selects video standard: 0 Cancel previous setting at this <pref> level 1 H.261 2 H.263
<resol>	This subparameter selects the video frame resolution: 1 SQCIF 2 QCIF 3 CIF 4 CIF4 5 CIF16
<urv>	This boolean selects whether the Unrestricted Vector coding option is requested in H.263 Video Mode requests. Default 0.
<arith>	This boolean selects whether the Arithmetic Coding option is requested in H.263 Video Mode requests. Default 0.
<advpred>	This boolean selects whether the Advanced Prediction option is requested in H.263 Video Mode requests. Default 0.
<pbframes>	This boolean selects whether the PB Frames option is requested in H.263 Video Mode requests.

### Default values

Default values are manufacturer defined.

### Read syntax

+SVM?

This returns a list of all +SVM commands in effect in the DCE, one per line, of the form:

+SVM: <vcode>,<pref>,<std>,<resol>[,<urv>,<arith>,<advpred>,<pbframes>]

### Test syntax

+SVM=?

The DCE shall transmit the range of capabilities for each possible incoming video sink, one sink per line.

NOTE – A DCE response enumerating multiple channels does not imply that these capabilities are available simultaneously.

## 3.8 Data indication reporting, +SDR

### Parameter

+SDR=<value>

### Description

This parameter controls whether or not the +SDI: indications will be generated by the DCE when data channels are established or closed.

NOTE – In the case of data channel 0, which is assigned to the DTE serial port, generation of +ER and +DR indications, if any, are independently controlled by the +ER and +DR commands in V.250 (ex-V.25 *ter*).

## Values

<value>	0	DCE shall not generate +SDI : indications.
	1	DCE shall generate +SDI : indications.

## Default values

Recommended default value is zero.

## Read syntax

+SDR?

This returns the current setting, e.g.:

+SDR: 0

## Test syntax

+SDR=?

The DCE shall return:

+SDR: ( 0 , 1 )

## 3.9 Audio indication reporting, +SARR

### Parameter

+SARR=<value>

### Description

This parameter controls whether or not the +SAR : and +SAT : indications will be generated by the DCE when audio channels are established or closed.

## Values

<value>	0	DCE shall not generate +SAR : and +SAT : indications.
	1	DCE shall generate +SAR : and +SAT : indications.

## Default values

Recommended default value is zero.

## Read syntax

+SARR?

This returns the current setting, e.g.:

+SARR: 0

## Test syntax

+SARR=?

The DCE shall return:

+SARR: ( 0 , 1 )

## 3.10 Video indication reporting, +SVRR (Class 18 only)

### Parameter

+SVRR=<value>

## Description

This parameter controls whether or not the +SVR: and +SVT: indications will be generated by the DCE when video channels are established or closed.

## Values

<value>	0	DCE shall not generate +SVR: and +SVT: indications.
	1	DCE shall generate +SVR: and +SVT: indications.

## Default values

Recommended default value is zero.

## Read syntax

+SVRR?

This returns the current setting, e.g.:

+SVRR: 0

## Test syntax

+SVRR=?

The DCE shall return:

+SVRR: ( 0 , 1 )

## 3.11 Capabilities indication reporting, +SCRR

### Parameter

+SCRR=<value>

### Description

This parameter controls whether or not the +SRCV: , +SRCA, +SRCD and +SRSC: indications will be generated by the DCE when capabilities are received from the remote terminal.

### Values

<value>	0	DCE shall not generate +SCRn: and +SRSC: indications.
	1	DCE shall generate +SCRn: and +SRSC: indications.

### Default values

Recommended default value is zero.

### Read syntax

+SCRR?

This returns the current setting, e.g.:

+SCRR: 0

## 4 Additional commands

### 4.1 Set audio code, +VAC

## Parameter

+VAC=<acode>

## Description

This parameter sets the audio device that is affected by subsequent +Vxxx commands in this clause (i.e., +VRL, +VSP, +VTA, +VTH, +VDX, +VHC). These commands will be directed to the specified audio device until modified by a subsequent +VAC command.

## Values

<acode> This is a supported audio device code as defined in 2.1.

## Default value

The default value is manufacturer-specific.

## Read syntax

+VAC?

This returns the current setting, e.g.:

+VAC: S0

## 4.2 Receive gain selection, +VGR

### Parameter

+VGR=<gain>

### Subparameter description

This command causes the DCE to set the gain for a receive audio channel.

The receive gain is an unsigned octet where values larger than 128 indicate a larger gain than nominal, and values smaller than 128 indicate a gain smaller than nominal. The nominal value is 128. The largest range of numbers is 0 to 255. The DCE may limit the receive gain to a more narrow range, such as 120 to 136 or 120 to 128. The value of zero is reserved for DCE Automatic Gain Control (AGC).

This command may be issued prior to the opening of a receive audio channel and its assignment to an audio output device. In this case, the gain setting for the device is stored, and becomes effective when the channel is opened.

### Defined values

<gain> This sets the receive channel gain as described above.

### Default values

Default value for <gain> shall be either 0 or 128.

### Read syntax

+VGR?

The DCE shall transmit the current setting for each existing incoming audio channel, one channel per line, e.g.:

+VGR: S0,128

for an audio channel delivered to a speaker at the nominal gain.

## Test syntax

+VGR=?

The DCE shall transmit the range of receive gain for each possible incoming audio channel, one channel per line, e.g.:

+VGR: S0, (1-255)

+VGR: L, (128)

for a DCE capable of implementing a full range a gain adjustment on speaker S0, but not AGC, and capable of delivering audio to the local telephone port at only the nominal level.

NOTE – A DCE response enumerating multiple channels does not imply that these capabilities are available simultaneously.

## 4.3 Transmit gain selection, +VGT

### Parameter

+VGT=<gain>

### Subparameter description

This command causes the DCE to set the gain for a transmit audio channel.

The transmit gain is an unsigned octet where values larger than 128 indicate a larger gain than nominal, and values smaller than 128 indicate a gain smaller than nominal. The nominal value is 128. The largest range of numbers is 0 to 255. The DCE may limit the gain to a more narrow range, such as 120 to 136 or 120 to 128. The value of zero is reserved for DCE Automatic Gain Control (AGC).

This command may be issued prior to the opening of a transmit audio channel and its assignment to an audio input device. In this case, the gain setting for the device is stored, and becomes effective when the channel is opened.

### Defined values

<gain>            This sets the transmit channel gain as described above.

### Default values

Default value for <gain> shall be either 0 or 128.

### Read syntax

+VGT?

The DCE shall transmit the current setting for each existing outgoing audio channel, one channel per line, e.g.:

+VGT: M0, 128

for an audio channel accepted from a microphone at the nominal gain.

## Test syntax

+VGT=?

The DCE shall transmit the range of transmit gain for each possible outgoing audio channel, one channel per line, e.g.:

+VGT: M0, (1-255)

+VGT: L, (128)

for a DCE capable of implementing a full range a gain adjustment on microphone M0, but not AGC, and capable of accepting audio from the local telephone port at only the nominal level.

NOTE – A DCE response enumerating multiple channels does not imply that these capabilities are available simultaneously.

#### **4.4 Beep tone duration timer, +VTD**

##### **Parameter**

+VTD=<dur>

##### **Parameter description**

This command sets the default DTMF/tone generation duration used by the DCE in conjunction with the +VTS command.

This command does not affect the settings for the ATD command.

##### **Defined values**

<dur>	0	Specifies a manufacturer-specific duration.
	1..255	Specifies the duration in units of 0.01 second.

##### **Default values**

Default value for <spmode> shall be 0.

##### **Read syntax**

+VTD?

The DCE shall transmit the current setting, e.g.:

+VTD: 10

##### **Test syntax**

+VTD=?

The DCE shall transmit the range of values available in the DCE, e.g.:

+VTD: (1-255)

#### **4.5 DTMF and tone generation, +VTS**

##### **Parameter**

+VTS=<string>

##### **Parameter description**

This command causes the DCE to produce DTMF tones, single frequency tones, and optionally, double frequency tones. This command allows the DTE to generate a dialtone, busy, etc. for those DCEs capable of generating two arbitrary tones.

The DCE support for the second tone generation is optional.

The DCE shall stop the tone generation at the point in the string where the DCE detects a parsing error, encounters an invalid frequency range, encounters a <CR>, or encounters a semi-colon.

If the target audio device is an audio output device, the tones are delivered to the device.

If this is an input device, and the device is associated with a transmit audio channel, the tones are delivered to the remote device. This accomplished by instructing the remote DCE to generate the tones via a DCE-DCE message, if enabled. If such DCE-DCE messaging is not available, the tones are generated by the local DCE, input to the audio coder, and transported as coded audio over the transmit audio channel. If the input audio device is not associated with a transmit audio channel, an ERROR result code is returned.

### Defined values

<string> The tone generation string shall consist of elements: in a list with where each element is separated by commas. Each element can be:

- 1) a single ASCII character in the set, 0-9, #, \*, !, and A-D;
- 2) a string drawn from the set but not including ! enclosed in square brackets, "[ ]";  
or
- 3) a string enclosed in curly braces "{ }".

The DCE shall interpret item 1), a single ASCII character, as a DTMF digit except for ! as a hookflash with a duration given by the +VTD command. The DCE shall interpret item 2), quantity in the square brackets, as a general dual tone and duration selection. The DCE shall interpret item 3), quantity in the curly braces, as a DTMF tone or hookflash with a different duration than that given by the +VTD command.

The quantity in the square brackets consists of a three-element list. The first element is the first frequency, the second element is the second frequency, and the third element is the duration in 0.01-second intervals. A list may contain null elements. For example, [3000] means that the DCE generates a single tone at 3000 Hz for the default duration; [3000,3300] means that the DCE generates a dual tone at 3000 and 3300 Hz for the default duration; and [,3300] means that the DCE generates a single tone at 3300 Hz for the default duration.

The quantity in the curly braces consists of a two-element list. The first element is the DTMF tone or hookflash (!) character, and the second element is the duration in 0.01 second. The characters are of the same set given above. A list may contain null elements. For example, {2} means DTMF tone "2" for the default duration, and {} means silence for the default duration.

### Default values

Missing subparameters assume the default value. Unspecified values always default to zero for frequencies, DTMF \* for DTMF tones, and +VTD for duration. The omission of commas (and associated subparameters) are valid.

### Test syntax

+VTS=?

The DCE shall transmit the range of values available in the DCE, e.g.:

<freq1>,<freq2>,<dur>

where the <freq1>, <freq2>, and the <dur> subparameters comprise a compound range of values.

Zeros are implied in the response for the frequencies, even if the DCE does report the zeros. The DCE must support a non-zero <dur> parameter.

<freq1>: First frequency range.



<freq2>: Second frequency range.

<dur>: Duration range for the square brackets and curly braces constructs. The units are in 0.01 second. The range of the permitted values for the +VTD command shall be inclusive within the range of the <dur> subparameter.

## 4.6 Ring local phone, +VRL

### Parameter

+VRL=<ring\_duration>[,<silence\_duration>[,<ring\_duration>]...]

### Parameter description

This command causes the DCE to produce ringing voltage to the specified local phone. The command returns the OK result code immediately if all subparameters are found to be properly formatted; the actual production of ringing occurs "asynchronously". No separate indication is given to the DTE when the specified ring pattern has been completed. If the local phone is off-hook, then the ringing is not performed (although an OK result code is still produced); if the local phone goes off-hook during the ringing, then ring voltage is terminated and the remainder of the ringing is not performed.

### Defined values

<ring\_duration>,<silence\_duration> The +VRL command can accept a variable number of subparameters. All <x\_duration> subparameters are decimal values in the range 0 to 255, each in increments of 100 milliseconds. The first such subparameter indicates the duration of the first ringing segment of the ring pattern; the second subparameter, if present, indicates the duration of the silent period before the next segment of the ring pattern; the third subparameter indicates the duration of the second ringing segment; and so forth, alternatively specifying the duration of the ring and silence segment. Note that it is not necessary to indicate the amount of silence that follows the pattern separating it from the next pattern; it is the responsibility of the DTE to repeat the command (at, typically, 6-second intervals) if additional ring patterns are desired.

### Default values

The DCE shall support subparameter strings specifying a minimum of three <ring\_duration> subparameters; more may be supported.

### Test syntax

+VRL=?

(<ring\_duration\_range>),( <silence\_duration\_range> ),<max\_ring\_duration>

where <ring\_duration\_range> indicates the supported values for the <ring\_duration> subparameters, <silence\_duration\_range> indicates the supported values for the <silence\_duration> subparameters, and <max\_ring\_durations> indicates the number of <ring\_duration> subparameters that can appear in a single +VRL command (the <ring\_duration> subparameters are presumed to be separated by <silence-duration> subparameters).

If the DCE does not support generation of ringing on the local phone, the information text returned is:

( 0 ) , ( 0 ) , 0

The information text response:

( 0-255 ) , ( 0-255 ) , 3

indicates that the DCE supports the full range of values for both <ring\_duration> and <silence\_duration> subparameters, and the minimum three <ring\_duration> subparameters per string.

#### 4.7 Speakerphone ON/OFF, +VSP

##### Parameter

+VSP=<spmode>

##### Subparameter description

This command enables and disables speakerphone operation in the DCE.

This command may be issued prior to the opening of audio channels and their assignment to audio devices. In this case, the setting is stored, and becomes effective when a microphone (i.e., *Mn*) and speaker (i.e., *Sn*) audio channel are open.

If more than one microphone or speaker channel are open, speakerphone operation will not be active, regardless of the setting of <spmode>.

##### Defined values

<spmode>	0	Disable speakerphone operation in the DCE.
	1	Enable speakerphone operation in the DCE.

##### Default values

Default value for <spmode> shall be 0.

##### Read syntax

+VSP?

The DCE shall transmit the current setting, e.g.:

+VSP: 0

##### Test syntax

+VSP=?

The DCE shall transmit ERROR if speakerphone operation is not available in the DCE, or:

+VSP: ( 0 , 1 )

If it is available.

#### 4.8 Train acoustic echo-canceller, +VTA

##### Syntax

+VTA

##### Description

This action command trains the speakerphone function's acoustic echo-canceller. It is optionally used in duplex speakerphone mode.

The DCE shall return an OK result code at completion of training.

### **Abortability**

This command is not abortable.

### **Test syntax**

+VTA=?

The DCE shall return OK if the command is implemented, or ERROR if it is not.

### **Implementation**

Implementation of this command is optional.

## **4.9 Train hybrid echo-canceller, +VTH**

### **Syntax**

+VTH

### **Description**

This action command trains the echo-canceller on the hybrid in the local DCE associated with the connection to local telephone port <acode>. It is optionally with such local telephone devices when the connection is a 2-wire interface.

### **Abortability**

This command is not abortable.

### **Test syntax**

+VTH=?

The DCE shall return OK if the command is implemented, or ERROR if it is not.

### **Implementation**

Implementation of this command is optional.

## **4.10 Speakerphone configuration, +VDX**

### **Parameter**

+VDX=<spconfig>

### **Parameter description**

This command configures the speakerphone function's mode of operation to half-duplex or duplex.

This command may be issued prior to the opening of audio channels and their assignment to audio devices. In this case, the setting is stored, and becomes effective when a microphone (i.e., *Mn*) and speaker (i.e., *Sn*) audio channel are open.

NOTE – Duplex speakerphone operation may be available in some DCE channel configurations and not in others. If the DCE configuration is changed during duplex speakerphone operation, the +VDX parameter setting may be modified, and speakerphone operation may revert to the half-duplex configuration. The DTE may determine the current configuration with the +VDX? read syntax.

### **Defined values**

<spconfig>	0	Configure speakerphone in the DCE for half-duplex operation.
	1	Configure speakerphone in the DCE for duplex operation.

## Default values

Default value for <spconfig> shall be manufacturer defined.

## Read syntax

+VDX?

The DCE shall transmit the current setting, e.g.:

+VDX: 0

## Test syntax

+VDX=?

The DCE shall transmit the range of values available in the DCE, e.g.:

+VDX: ( 0 , 1 )

## 4.11 Phone hookswitch status, +VPH

### Parameter description

This is a read-only parameter, that reports the on-hook/off-hook status of local phone devices connected to the DCE (i.e., it reports whether the devices are drawing loop current from the DCE).

### Read syntax

+VPH?

The DCE shall transmit the current status for each local phone, e.g.:

+VPH: L0 , 1

+VPH: L1 , 0

Reports that the phone on L0 is drawing loop current, while the phone at L1 is not.

### Test syntax

+VPH=?

The DCE shall transmit the range of reportable values for each telephone port on the DCE configured for central office simulation, e.g.:

+VPH: L0 , ( 0 , 1 )

+VPH: L1 , ( 0 , 1 )

## 4.12 Telephony port hook control, +VHC

### Parameter

+VHC=<hookstat>

### Subparameter description

This command place on- and off-hook those telephone ports on the DCE that are configured for single-line telephone simulation.

### Defined values

<hookstat>	0	Place telephony port on hook.
	1	Place telephony port off hook.

## Default values

Default value for <hookstat> shall be 0 for all applicable <acode>'s.

## Read syntax

+VHC?

The DCE shall transmit the hook status for each local phone port configured for single-line telephone simulation, e.g.:

+VHC: L0,1

+VHC: L1,0

reports that port L0 is off hook, while the port L1 is on hook.

## Test syntax

+VHC=?

The DCE shall transmit the range of allowable values for each telephone port on the DCE configured for single-line telephone simulation, e.g.:

+VHC: L0,(0,1)

+VHC: L1,(0,1)

## 5 Indications

If so configured by the DTE, the DCE may generate information text indications that inform the DTE when channels are established or closed; for example, at the commencement of V.70 or H.324 operation.

These indications will typically be generated at the initiation of V.70/H.324 operation, after the +MR modulation reports, but before the CONNECT result code, which indicates that the data channel to the DTE is ready for operation, or before the OK final result code, which is used in the case of initial H.324 operation that does not include a data channel. Since a capabilities exchange takes place at the beginning of every H.324 session, a +SRC indication is always generated at this time.

NOTE – In the case of data channel 0, which is assigned to the DTE serial port, +ER and/or +DR indications may also be generated. These are independently controlled by the +ER and +DR commands in V.250 (ex-V.25ter). These indications may also be generated during a communication session as channels are established or closed, either directly to the DTE while in on-line command state, or in-band while in data state; see 7.1.

### 5.1 Remote terminal capabilities indications

These indications report the capabilities of the remote terminal, as reported by the terminal using H.245 procedures. The remote terminal reports at least its receive capabilities at least once during a communications session. The terminal may also report its transmit capability. The +SRCA, +SRCV, and +SRCD indications are used to report the remote terminal's capability table entry definitions. The +SRSC indications are used to report each of the remote terminal's simultaneous capability sets and reference the capability table entry definitions previously reported by the +SRCA, +SRCV, and +SRCD indications. The collection of +SRSC indications report the capability set of the remote terminal.



## Description

This indication reports the establishment or closing of a data channel with data channel identifier <rcode>, on port number <portnum>. Values are as defined in the +SDC command. An indication which just supplies the <rcode> value indicated that the corresponding data channel has been closed.

NOTE – In the case of data channel 0, which is assigned to the DTE serial port, +ER and/or +DR indications may also be generated. These are independently controlled by the +ER and +DR commands in V.25ter.

## 5.3 Audio receive channel indication, +SAR

### Format

+SAR: <rcode>,<portnum>,<std>,<arate> , <silsup> , [ <blockf> , <susresume> , <audioh> , <SuspendwAd> , <crc> , <n401> ]

### Description

This indication reports the establishment or closing of an incoming audio channel to audio device <rcode>, with port number <portnum>. Values are as defined in the +SAM command. An indication which just supplies the <rcode> value indicated that the corresponding audio channel has been closed.

## 5.4 Audio transmit channel indication, +SAT

### Format

+SAT: <rcode>,<portnum>,<std>,<arate> , <silsup> , [ <blockf> , <susresume> , <audioh> , <SuspendwAd> , <crc> , <n401> ]

### Description

This indication reports the establishment or closing of an outgoing audio channel from audio device <rcode>, with port number <portnum>. Values are as defined in the +SAC command. An indication which just supplies the <rcode> value indicated that the corresponding audio channel has been closed.

## 5.5 Video receive channel indication, +SVR (Class 18 only)

### Format

+SVR: <rcode> , <portnum> , <std> , <resol> [ , <urv> , <arith> , <advpred> , <pbframes> ]

### Description

This indication reports the establishment or closing of an incoming video channel to video device <rcode>, with port number <portnum>. Values are as defined in the +SVM command. An indication which just supplies the <rcode> value indicated that the corresponding video channel has been closed.

## 5.6 Video transmit channel indication, +SVT (Class 18 only)

### Format

+SVT: <rcode> , <portnum> , <std> , <qcifMPI> , <cifMPI> , <tstrate> , [ <scifMPI> , <cif4MPI> , <cif16MPI> , <urv> , <arith> , <advpred> , <pbframes> , <hrdBmaxKb> ]

## **Description**

This indication reports the establishment or closing of an outgoing video channel from video device <vcode>, with port number <portnum>. Values are as defined in the +SVC command. An indication which just supplies the <vcode> value indicated that the corresponding video channel has been closed.

## **6 Additional indications**

### **6.1 Audio code report, +VACR**

#### **Format**

+VACR: <acode>

#### **Description**

This indication proceeds the +VCIDR, +VDIDR, and +VTER indications defined in this clause. It indicates to which audio devices these subsequent indications apply. If consecutive indications in this clause are output by the DCE, the DCE may omit the intervening +VACR report.

### **6.2 Caller ID report, +VCIDR**

#### **Format**

+VCIDR: <string>

#### **Description**

Caller ID sequence detected at telephone port <acode>, which is configured for single-line telephone simulation. The <string> subparameter contains the entire received Caller ID information found in the single data message format, contained in the Single Data Message (SDM) and in the Multiple Data Message (MDM) packets, excluding the leading U's (line seizure information). The checksum shall be included. The <string> shall contain the entire Caller ID packet in hex as printable numbers. The characters in the hex message shall be in the bit order received by the DCE. The DCE shall include all message type octet(s), message length octet(s), data octet(s), and checksum octet(s).

### **6.3 DID report, +VDIDR**

#### **Format**

+VDIDR: <string>

#### **Description**

Direct Inward Dialing (DID) detected at telephone port <acode>, which is configured for telephone simulation. The content of <string> shall be a string of digits representing the DID information detected.

### **6.4 Simple telephony event report, +VTER**

#### **Format**

+VTER: <tcode>



## Description

Reports that event <rcode> was detected at the telephony device *Ln* indicated by <rcode>. Defined values of <rcode> are:

Code	Description
0-9	DTMF 0-9
A-D	DTMF A-D
E	DTMF *
F	DTMF #
h	Line current break (local phone goes on hook). (Note 1)
H	Line current detected (local phone goes off hook). (Note 1)
!	Hook-Flash (Line current interruption). (Note 1)
L	Loop current polarity reversal. This may indicate a hang-up or a receive depending on the implementation of the central office. (Note 2)
r	Ringback (cadence). (Note 2)
b	BUSY (cadence). If the DCE continues to detect BUSY, the DCE may repeatedly report this event. The time interval between reports shall be no less than 4.0 seconds. The detection criterion is implementation specific. (Note 2)
d	DIALTONE. If the DCE continues to detect DIALTONE, the DCE may repeatedly report this event. The time interval between reports shall be no less than 3.0 seconds. The detection criterion is implementation specific. (Note 2)
K	Reorder/fast busy (cadence). (Note 2)
p	Line voltage increase (extension phone goes on hook). (Note 2)
P	Line voltage decrease (extension phone goes off hook). (Note 2)
R (n)	Ring detected. The value of (n), if included, specifies distinctive ringing cadence detected. If n is omitted, standard ringing cadence (1) shall be assumed. Valid values for (n) are 1-4. (Note 2)
i	Stuttered dialtone. (Note 2)
NOTE 1 – Applicable when port is configured for central office simulation.	
NOTE 2 – Applicable when port is configured for single-line telephone simulation.	

## 7 In-band indications and commands

### 7.1 In-band indications

If so configured by the DTE, the DCE shall generate in-band indications reporting channel establishment, closing, etc., using the in-band procedures defined in clause 7/V.80, using the STATUS Extended in-band command. If this mode of operation is desired by the DTE and is available in the DCE, it shall be enabled with the +IBC command.

### 7.2 In-band commands

If so configured by the DTE, the DCE shall accept in-band commands for channel establishment, closing, reconfiguration, etc., using the in-band procedures defined in clause 7/V.80, using the CONTROL Extended-0 in-band command. If this mode of operation is desired by the DTE and is available in the DCE, it shall be enabled with the +IBC command. The DTE may use in-band +STC

commands to establish new channels or close existing ones. The DTE may use in-band +SDC, +SAC, +SAM, +SVC (Class 18 only), and +SVM (Class 18 only) commands to change the configuration of an existing channel. The DTE may use in-band +V commands defined in clause 4 to control audio and telephony operation.

### **7.3 Remote DCE in-band commands and indications**

The telephony control commands (+VRL, +VSP, +VTA, +VTH, +VDX, +VPH, +VHC) and the telephony indications (+VCIDR, +VDIDR, +VTER) may be exchanged between the local DTE and the remote DCE. These messages use the same syntax as the CONTROL and STATUS extended in-band commands for the local DCE, but the Extended-0 command code 45h is used for remote DCE commands, rather than 42h as is used for the local DCE, and 65h is used for remote DCE status reports, rather than 62h as is used for reports from the local DCE.

## ITU-T RECOMMENDATIONS SERIES

Series A	Organization of the work of the ITU-T
Series B	Means of expression: definitions, symbols, classification
Series C	General telecommunication statistics
Series D	General tariff principles
Series E	Overall network operation, telephone service, service operation and human factors
Series F	Non-telephone telecommunication services
Series G	Transmission systems and media, digital systems and networks
Series H	Audiovisual and multimedia systems
Series I	Integrated services digital network
Series J	Transmission of television, sound programme and other multimedia signals
Series K	Protection against interference
Series L	Construction, installation and protection of cables and other elements of outside plant
Series M	TMN and network maintenance: international transmission systems, telephone circuits, telegraphy, facsimile and leased circuits
Series N	Maintenance: international sound programme and television transmission circuits
Series O	Specifications of measuring equipment
Series P	Telephone transmission quality, telephone installations, local line networks
Series Q	Switching and signalling
Series R	Telegraph transmission
Series S	Telegraph services terminal equipment
Series T	Terminals for telematic services
Series U	Telegraph switching
<b>Series V</b>	<b>Data communication over the telephone network</b>
Series X	Data networks and open system communications
Series Y	Global information infrastructure
Series Z	Programming languages