



INTERNATIONAL TELECOMMUNICATION UNION

**ITU-T**

TELECOMMUNICATION  
STANDARDIZATION SECTOR  
OF ITU

**U.202**

(03/93)

**TELEGRAPH SWITCHING  
INTERNATIONAL TELEX SERVICE**

---

**TECHNICAL REQUIREMENTS TO BE MET IN  
PROVIDING THE INTERNATIONAL TELEX  
SERVICE WITHIN AN INTEGRATED  
SERVICES DIGITAL NETWORK**

**ITU-T Recommendation U.202**

(Previously "CCITT Recommendation")

---

## FOREWORD

The ITU Telecommunication Standardization Sector (ITU-T) is a permanent organ of the International Telecommunication Union. The ITU-T is responsible for studying technical, operating and tariff questions and issuing Recommendations on them with a view to standardizing telecommunications on a worldwide basis.

The World Telecommunication Standardization Conference (WTSC), which meets every four years, established the topics for study by the ITU-T Study Groups which, in their turn, produce Recommendations on these topics.

ITU-T Recommendation U.202 was revised by the ITU-T Study Group IX (1988-1993) and was approved by the WTSC (Helsinki, March 1-12, 1993).

---

## NOTES

1 As a consequence of a reform process within the International Telecommunication Union (ITU), the CCITT ceased to exist as of 28 February 1993. In its place, the ITU Telecommunication Standardization Sector (ITU-T) was created as of 1 March 1993. Similarly, in this reform process, the CCIR and the IFRB have been replaced by the Radiocommunication Sector.

In order not to delay publication of this Recommendation, no change has been made in the text to references containing the acronyms "CCITT, CCIR or IFRB" or their associated entities such as Plenary Assembly, Secretariat, etc. Future editions of this Recommendation will contain the proper terminology related to the new ITU structure.

2 In this Recommendation, the expression "Administration" is used for conciseness to indicate both a telecommunication administration and a recognized operating agency.

© ITU 1994

All rights reserved. No part of this publication may be reproduced or utilized in any form or by any means, electronic or mechanical, including photocopying and microfilm, without permission in writing from the ITU.

## CONTENTS

	<i>Page</i>
Scope .....	1
PART I – GENERAL CONSIDERATIONS APPLICABLE TO ALL CONFIGURATIONS .....	1
1 General principles .....	1
2 Quality of Service objectives .....	2
3 Configuration models .....	2
3.1 Minimum integration .....	2
3.2 Maximum integration .....	3
4 Terminal adaptors.....	4
PART II – USE OF THE B-CHANNEL OF THE ISDN IN CIRCUIT MODE FOR THE PROVISION OF THE INTERNATIONAL TELEX SERVICE .....	4
1 Minimum integration model.....	4
2 Maximum integration model .....	4
3 Call establishment sequences .....	4
3.1 Minimum integration model .....	4
3.2 Maximum integration model.....	8
4 Terminal adaptor functions .....	10
5 Access unit .....	10
6 Tasks of the interworking function .....	10
7 Other telex service features .....	10
PART III – USE OF THE D-CHANNEL FOR THE PROVISION OF THE INTERNATIONAL TELEX SERVICE .....	10
1 Quality of Service .....	10
2 Switching signalling.....	10
3 Text and data transmission .....	11
4 Telex access points.....	11
5 Telex-to-ISDN connections and vice versa.....	11
6 Special procedures for different configuration models, incorporating switching .....	11
7 Switching signalling conversion .....	16
8 Conversion of telex message characters.....	16
9 Recapitulation .....	17

## **INTRODUCTION**

Recognizing that some Administrations have implemented, or plan to implement, integrated services digital networks (ISDN) in accordance with I-Series Recommendations, there may be economic and operational benefits to be gained if the international telex service was also supported within the ISDN environment. Accordingly, the provisions of this Recommendation should be followed whenever the ISDN is used to support the international telex service.

**TECHNICAL REQUIREMENTS TO BE MET IN PROVIDING  
THE INTERNATIONAL TELEX SERVICE WITHIN  
AN INTEGRATED SERVICES DIGITAL NETWORK**

*(Melbourne, 1988; revised at Helsinki, 1993)*

**Scope**

This Recommendation is structured in three parts, as follows:

- Part I: General considerations applicable to all configurations
- Part II: Use of the B-channel of the ISDN in circuit mode for the provision of the international telex service
- Part III: Use of the D-channel for the provision of the international telex service

This Recommendation lays down general principles to be followed and outlines configuration models for the provision of the international telex service in the ISDN environment. It is assumed throughout this Recommendation that the service and operational provisions in respect of the international telex service, as detailed in Recommendations F.59 and F.60, are maintained in all identified configurations.

The specification of the interface between the telex terminal and terminal adaptor within the ISDN is outside the scope of this Recommendation.

**PART I – GENERAL CONSIDERATIONS APPLICABLE TO ALL CONFIGURATIONS**

**1 General principles**

- i) The service principles and basic characteristics of the international telex service, detailed in Recommendations F.59 and F.60, must be applied and maintained end-to-end.
- ii) No burden shall be placed on existing telex networks in setting up telex connections to telex terminals connected to the ISDN and accordingly single-stage call set-up shall be employed in either direction.
- iii) The plan for telex destination codes contained in Recommendation F.69 shall be applied in sending telex calls towards an ISDN which supports the international telex service from an existing telex network in another country which has not implemented an ISDN environment.
- iv) Accordingly, ISDN-based telex terminals should be assigned a telex number which is part of the national telex numbering plan. However, an integrated numbering plan may be employed in national implementations provided the maximum number of digits required to address an ISDN-based subscriber across the international telex network does not exceed 12 in accordance with the U-Series signalling Recommendations.
- v) The technical requirements in relation to subscriber-to-subscriber performance, permissible distortion levels, and signal transfer delay, as specified in Recommendations R.58, R.58 *bis*, and U.8 shall be met in all cases.
- vi) A telex terminal connected to an ISDN should respond to a received WRU signal by transmitting its answerback sequence formatted in accordance with Recommendation F.60 with a maximum delay of 600 ms from receipt of the second start element within the WRU signal, in accordance with Recommendation S.6.

## 2 Quality of Service objectives

In accordance with the provisions of the F-Series Recommendations, and in particular Recommendations F.59 and F.60, the Quality of Service objectives, as defined in the referenced Recommendations and as perceived by subscribers of the international telex service, shall be met in all configurations where the international telex service is provided in the ISDN environment. Accordingly, telex subscribers connected to an ISDN and participating in the international telex service shall see no degradation in the Quality of Service which they would experience if connected to a dedicated telex network. Conversely, telex subscribers connected to a dedicated telex network shall see no degradation in their Quality of Service when sending telex messages to ISDN-based telex subscribers across international boundaries.

## 3 Configuration models

Several configuration models may be developed by each Administration (or ROA), depending on the extent to which the telex service is integrated into the ISDN. These models range from minimum integration to maximum integration as described below.

### 3.1 Minimum integration

The minimum degree of integration is where the ISDN is used only as a means of connecting terminals to a serving exchange, with all switching occurring within the telex network.

In this configuration, the link between the terminal and the telex network is therefore equivalent to a subscriber line built across the ISDN.

This method requires the availability both of a telex network and an ISDN. An ISDN subscriber should normally be able to use it to connect his telex, although there may also be telex subscribers, who do not subscribe to the ISDN and who are connected by the usual means.

If either of the two countries X or Y use minimum integration of telex into ISDN, the link between those countries for international telex calls can only be established over the international network (see Figure 1).

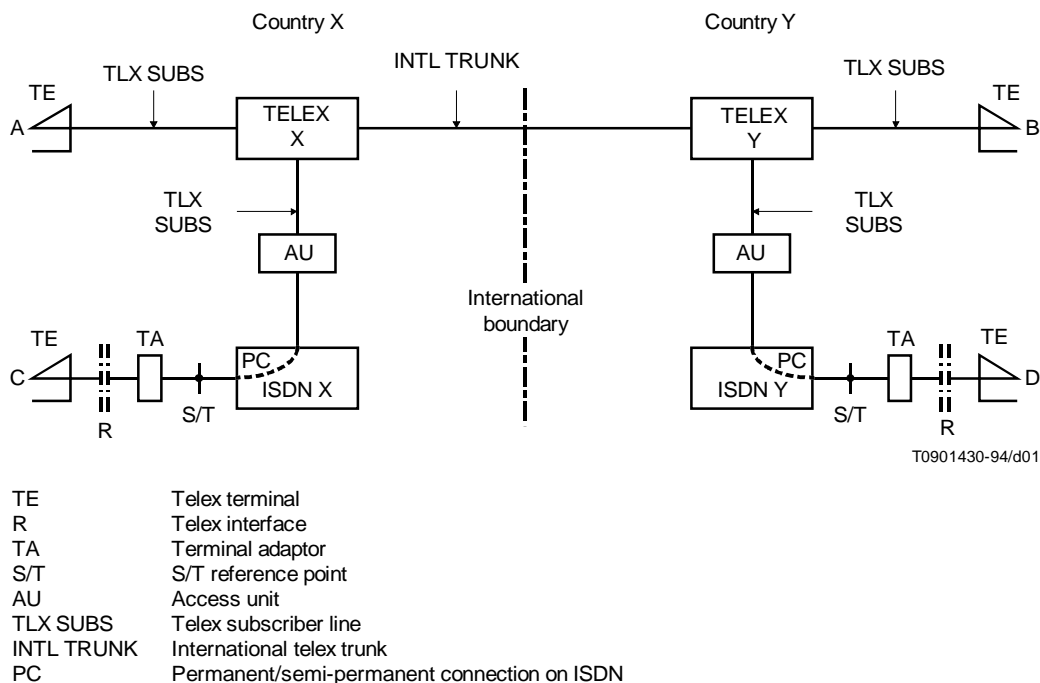

FIGURE 1/U.202

Minimum integration model

### 3.2 Maximum integration

More complex configuration models might be considered where the switching is also integrated within the ISDN, to a greater or lesser extent.

In these types of configuration, the link-up between the ISDN and the telex network will be at circuit level.

In the extreme case, an Administration might consider replacing its telex network with an ISDN, to which all telex subscribers would be connected. In this case, the technical means should be provided for applying the telex service's own call establishment and connection procedures not normally available in the ISDN.

If the two countries X and Y use both maximum integration (see Figure 2), the link between them for a telex call can be established either over the international telex network or by interconnection of their ISDNs. This last possibility must be agreed bilaterally.

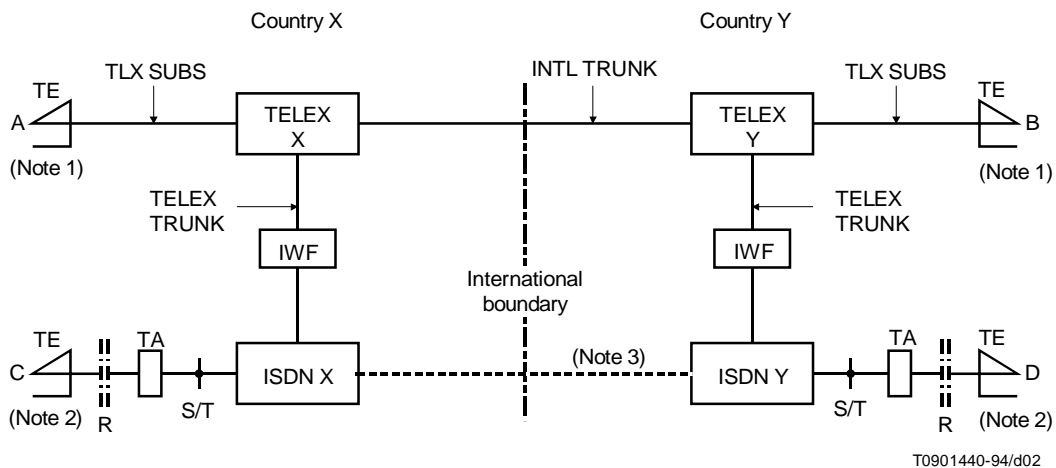

A, B	Telex terminals on a telex network
C, D	Telex terminals within an ISDN network
IWF	Interworking facility
TA	Terminal adaptor
TLX SUBS	Telex subscriber line
TELEX TRUNK	Telex national trunk
INTL TRUNK	Telex international trunk

#### NOTES

- 1 For calls originated from the telex network (e.g. A to C or B to C), the destination telex network should be able to route calls intended for telex subscribers within the ISDN to the IWF. The IWF will perform the address validation and translation if necessary. The actual number assignment is a national matter.
- 2 For calls originated by telex terminals within the ISDN (e.g. C to A or C to B), the ISDN should route these calls to the national IWF. This may imply the use of escape code sequences before time "T", or other means as appropriate. (Concept of time "T" is defined in Study Group II's Recommendation E.165.)
- 3 Interconnection of ISDNs to support the telex service should be agreed bilaterally.

FIGURE 2/U.202  
Maximum integration model

## **4 Terminal adaptors**

The usual type of telex terminal model, connected on the ISDN, should be equipped with a terminal adaptor (TA), or an equivalent internal mechanism, which can provide the extra functions and conditions required as a result of connection to the ISDN.

The interface between terminals and adaptors should be a national matter.

The supply of telex terminals specially designed for connection to the ISDN should remain optional, for decision at national level.

## **PART II – USE OF THE B-CHANNEL OF THE ISDN IN CIRCUIT MODE FOR THE PROVISION OF THE INTERNATIONAL TELEX SERVICE**

### **1 Minimum integration model**

The connection across the ISDN may be provided on a permanent, or semi-permanent basis, however, access to the telex network must be provided on a dedicated basis per subscriber.

The B-Channel in circuit mode of the ISDN is used for the text transmission

### **2 Maximum integration model**

Where the Administration provides both a telex network and an ISDN, then the signalling system to be used between the interworking function and the telex network is a national matter. However, it is recommended that signalling systems in accordance with CCITT Recommendation U.11 or U.12 be used.

It is recommended that where an ISDN only is provided, then connection to telex networks of other Administrations should be in accordance with CCITT U-Series Recommendations, preferably U.11 or U.12.

Interconnection of ISDNs to support the telex service should be agreed bilaterally.

The B-Channel circuit mode of the ISDN is used for the text transmission.

The routing of the call through the ISDN is a national matter.

### **3 Call establishment sequences**

#### **3.1 Minimum integration model**

Where connection across the ISDN is provided on a permanent basis, the telex call establish sequences will take place on the B-Channel.

Typical telex subscriber outgoing and incoming signal sequences should be in accordance with the examples given in Figure 3 and Figure 4 respectively.

The method of establishing the permanent connection across the ISDN is a national matter.

Where connection across the ISDN is on a semi-permanent basis, typical telex subscriber outgoing and incoming signal sequences should be in accordance with Figures 3, and Figure 4 respectively.

The method of establishing the semi-permanent connection is a national matter, but the outgoing and incoming call establishment sequences may be in accordance with Figures 5 and 6 respectively.



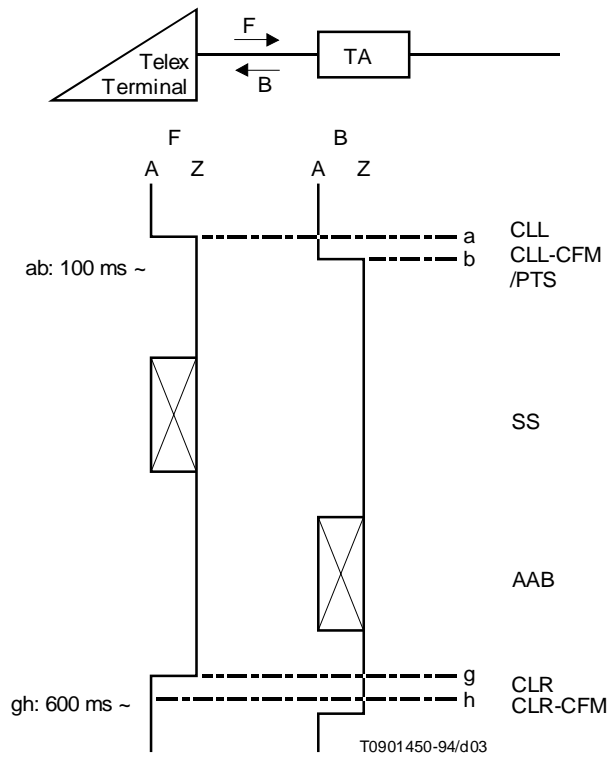

FIGURE 3/U.202  
 Typical telex subscriber's outgoing signal sequence

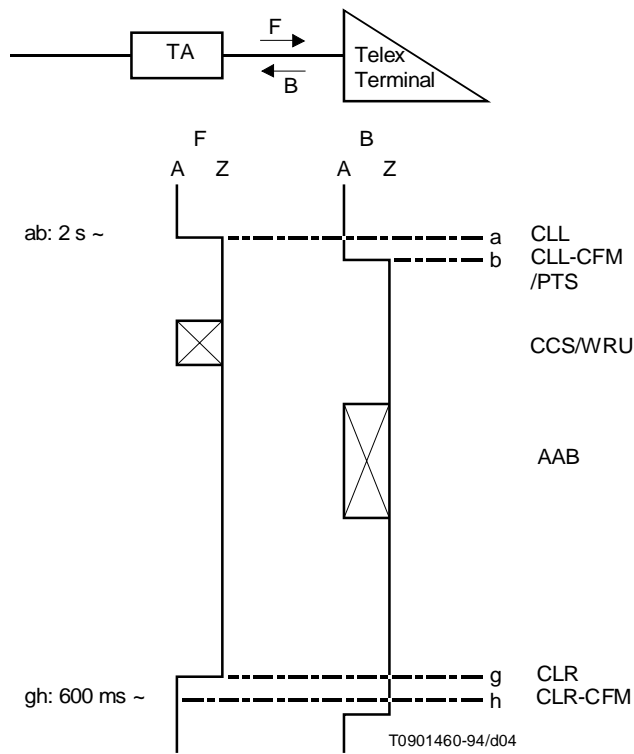
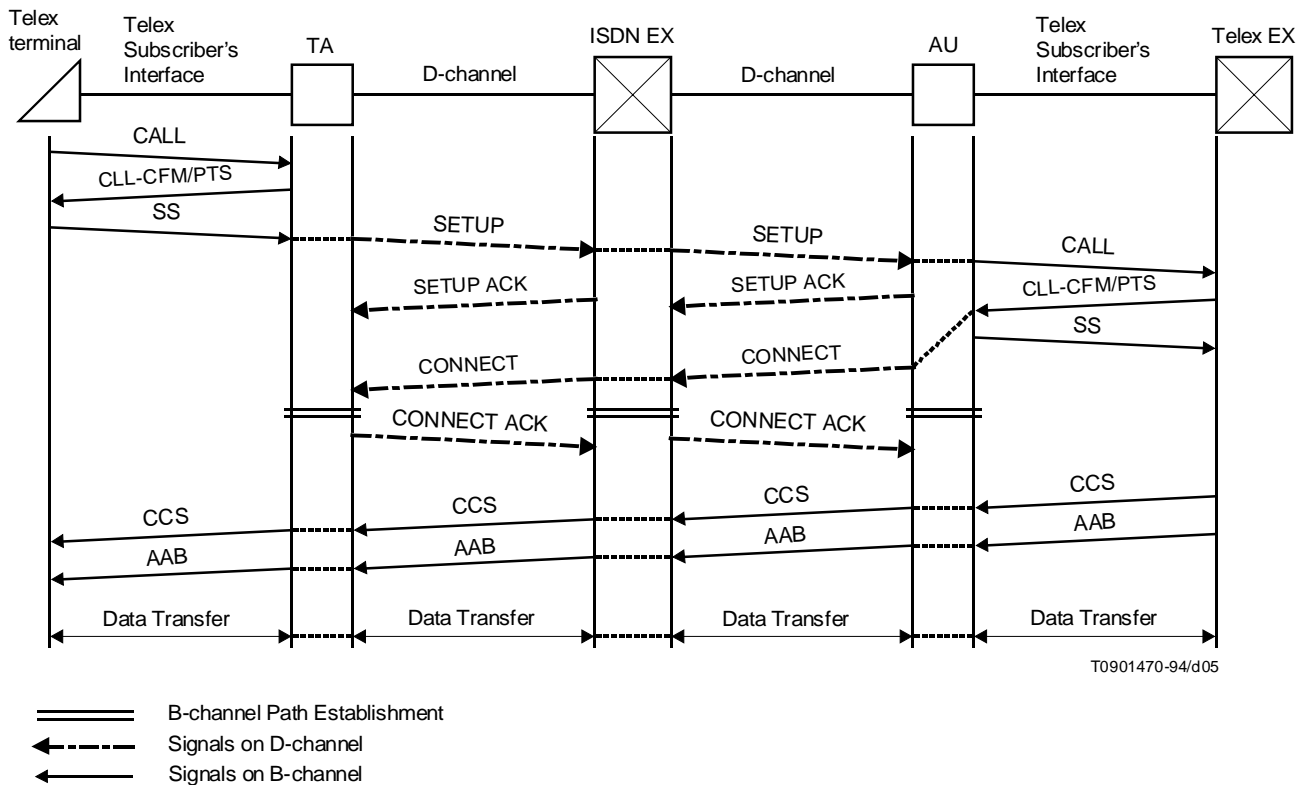
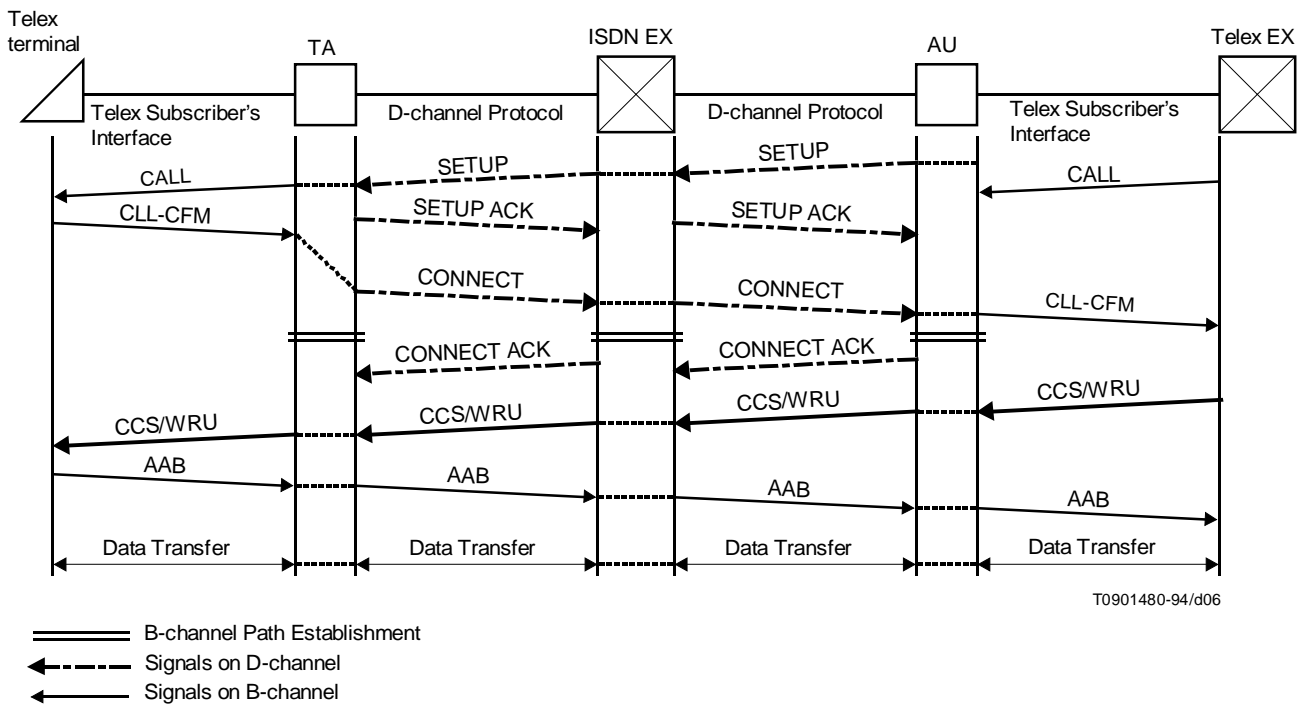

FIGURE 4/U.202  
 Typical telex subscriber's incoming signal sequence



NOTE – In case of a permanent connection no ISDN signalling in the D-channel occurs.

FIGURE 5/U.202  
**Call establishment sequence in the direction of an ISDN to a telex network  
 (minimum integration model)**



NOTE – In case of a permanent connection to ISDN signalling in the D-channel occurs.

FIGURE 6/U.202  
**Call establishment sequence in the direction of a telex network to an ISDN  
 (minimum integration model)**

### 3.2 Maximum integration model

Where Administrations implement the maximum integration model, telex subscribers connected to the ISDN may communicate with other telex subscribers connected to the same ISDN and to telex subscribers connected to existing telex networks.

Typical telex subscriber outgoing and incoming signal sequences should be in accordance with Figures 3 and 4 respectively.

The outgoing and incoming call establishment sequences should be in accordance with Figures 7 and 8 respectively.

Where translation from the international telex number to the ISDN number (E.164) for routing purposes is required, this should be done in the IWF.

The Administration providing the telex service within the ISDN is responsible for providing this translation.

The method for forwarding the service signals issued by the dedicated telex network to the telex subscriber on the ISDN, is for further study.

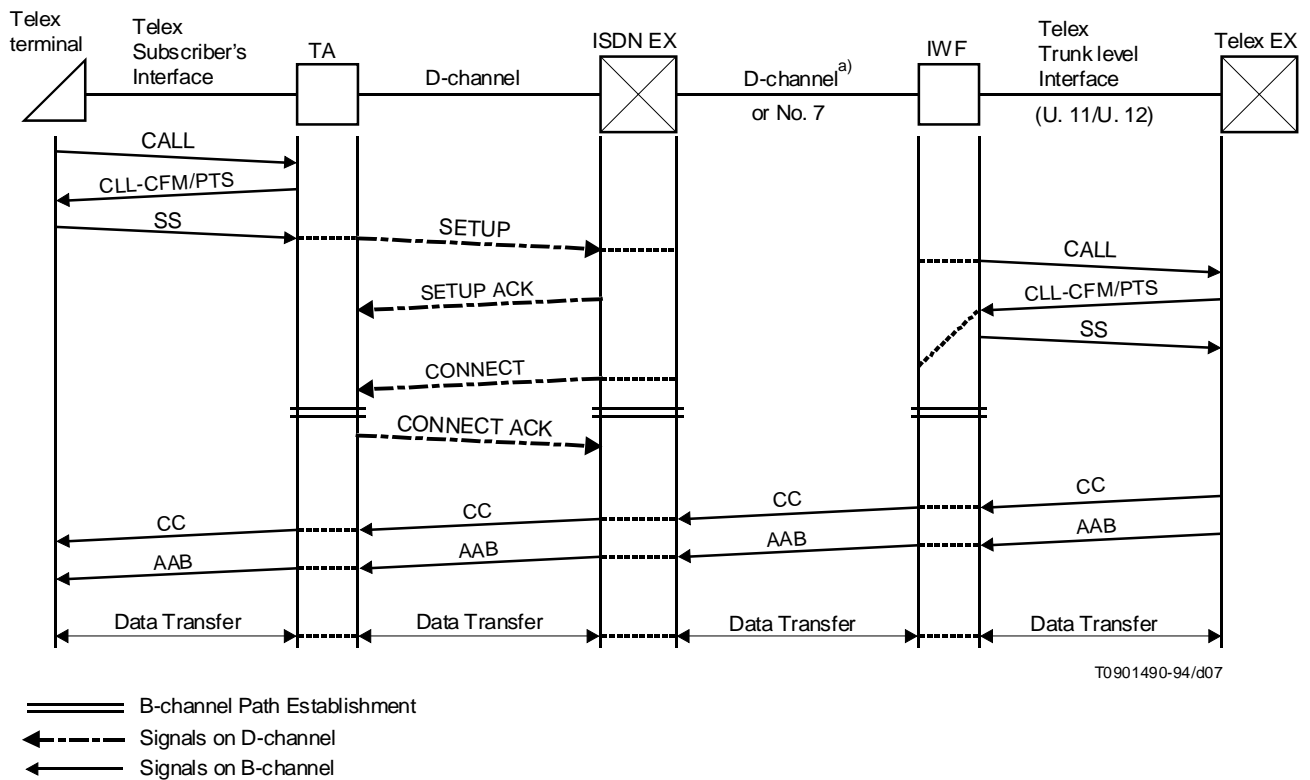

T0901490-94/d07

FIGURE 7/U.202  
Call establishment sequence in the direction of ISDN to telex network  
(maximum integration model)

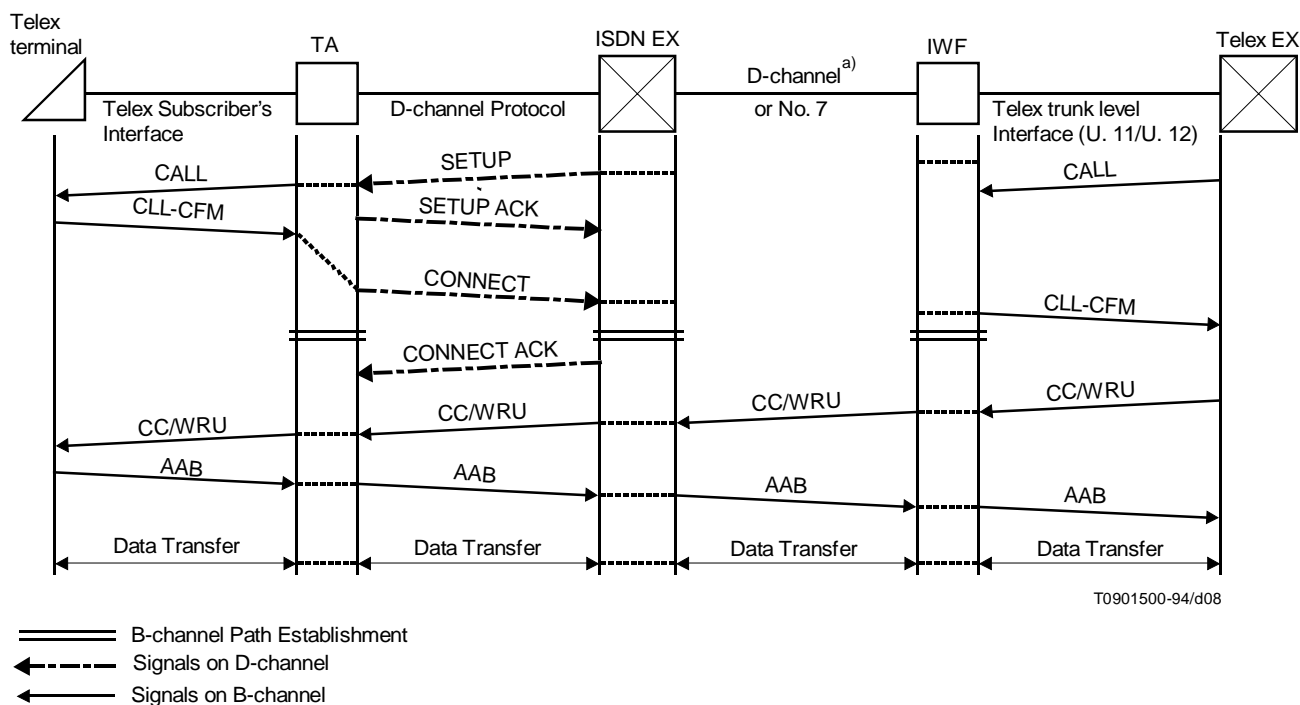

a) The details are for further study.

FIGURE 8/U.202  
Call establishment sequence in the direction of telex network to ISDN  
(maximum integration model)

**Legend to Figures 3, 4, 5, 6, 7 and 8:**

CALL	Calling signal
CLL-CFM	Call confirmation signal
SS	Selection signal
CC	Call connected signal
AAB	Automatic answerback signal
WRU	✱ (Who are you?) signal
CLR-CFM	Clear confirmation signal
CLR	Clearing signal
SETUP	Setup message
SETUP ACK	Setup acknowledgement message
CONNECT	Connect message
CONNECT ACK	Connect acknowledgement message
TA	Terminal adaptor
AU	Access unit
EX	Exchange
IWF	Interworking facility

## **4 Terminal adaptor functions**

The following terminal adaptor functions will be required.

### **Rate adaption**

The telex speed of 50 bauds will be converted to the ISDN B-Channel speed of 64 kbit/s, and vice versa.

The method of achieving this conversion is for further study.

### **Signal sequence mapping**

The telex subscriber signal sequences will be converted to the ISDN D-Channel signalling protocol, and vice versa.

## **5 Access unit**

The provision of an access unit, for the minimum integration model is a national matter and is not a subject for international standardization. However, similar functions to those identified for the terminal adapter will be required.

## **6 Tasks of the interworking function**

The following interworking functions will be required.

### **Rate adaption**

The IWF will convert the telex speed of 50 bauds to the ISDN B-Channel speed of 64 kbit/s, and vice versa. The method of achieving this conversion is for further study.

### **Selection signal mapping**

The telex selection signals will be converted to ISDN selection signal requirements, and vice versa. The method of achieving this conversion is for further study.

### **Address translation**

The method for translating the international telex number to the ISDN E.164 number, if required, is a national matter.

## **7 Other telex service features**

The provision of other telex service features in the ISDN is for further study.

## **PART III – USE OF THE D-CHANNEL FOR THE PROVISION OF THE INTERNATIONAL TELEX SERVICE**

### **1 Quality of Service**

Overall terminal-to-terminal service quality should not be affected by use of the ISDN. In particular, the delays in transmission indicated in Recommendation X.135 will need to be taken into account.

The influence of packetizing, in particular on conversational mode, is for further study.

### **2 Switching signalling**

All call establishment and disconnect signals should be transmitted over the D-channel of the ISDN, in conformity with the principle set out in clause 1 above, and in accordance with the arrangements explained in 6 and 7 below (see Figures 3 and 4).

### **3 Text and data transmission**

For the transmission of telex texts and data channel D in packet mode of the subscriber access to the ISDN is used.

The advantage of this method is that it would leave the B-channels available for telephone or high-speed data transmission, without impairing signalling transmission, or even other low-speed data transmission in channel D.

### **4 Telex access points**

All the functions related to adapting and converting modes, formats and procedures between the ISDN and the telex network should be provided by telex access points (PAX); direct connections must be possible at these access points to interfaces with the ISDN in packet mode, either at trunk level or at subscriber line level.

The location of the PAXs, either in the telex centres or in other telecommunication centres, should be decided nationally. However, it would be beneficial to reduce the number of connections required between PAXs and local ISDN centres.

### **5 Telex-to-ISDN connections and vice versa**

ISDN interfaces at telex access points may consist of permanent logical links (PLL), built through the ISDN subscriber's D-channel, and possibly extended by switching across the ISDN, which, when activated, allows without any previous signalling or numbering stage the transfer in both directions of telex signalling data and characters (see Figures 9 and 10).

These PLLs should be used in packet mode in conformity with Recommendation X.25.

The PLL is identified in the ISDN by a parameter indicating the service access point identifier (SAPI), a parameter identifying the user's terminal (TEI) and another one identifying the link on the PAX side. It is activated as soon as a telex communication is asked for, whereupon all the data links which constitute it are established.

However, there are other possible solutions based on switching access, which would use interface procedures in an X.31 type packet mode service in the ISDN.

### **6 Special procedures for different configuration models, incorporating switching**

#### **ISDN numbering**

In this type of configuration, an internal ISDN call number, complying with the general numbering plan of the network (see Recommendation E.164), should be allocated to any telex terminal which is connected, in addition to the telex call number.

A call to a terminal connected on the ISDN shall be routed according to this ISDN call number and in conformity with the internal procedure of the network.

The conversion of a telex call number into an ISDN number, and vice versa will be effected from the telex access point, which has access to the table of corresponding numbers.

The interlinking of two terminals connected by the ISDN within the same country is a national matter. Since the interconnection procedure, however, used by the terminals is the telex procedure, a telex processor with functions equivalent to those of the PAX will have to be used.

Two Administrations can be directly interconnected on the ISDN and they may wish to use this interconnection to establish telex relations. This would require a bilateral agreement, specifying in particular how the telex call establishment procedure would be applied and who would be responsible for the supplies.

In any event, call requests coming from a subscriber on the ISDN, or from a subscriber on the telex to a subscriber on the ISDN, should be routed to the telex access point, or the equivalent processor, which will be required to carry out the necessary procedures and signal conversions (see Figures 11 and 12).

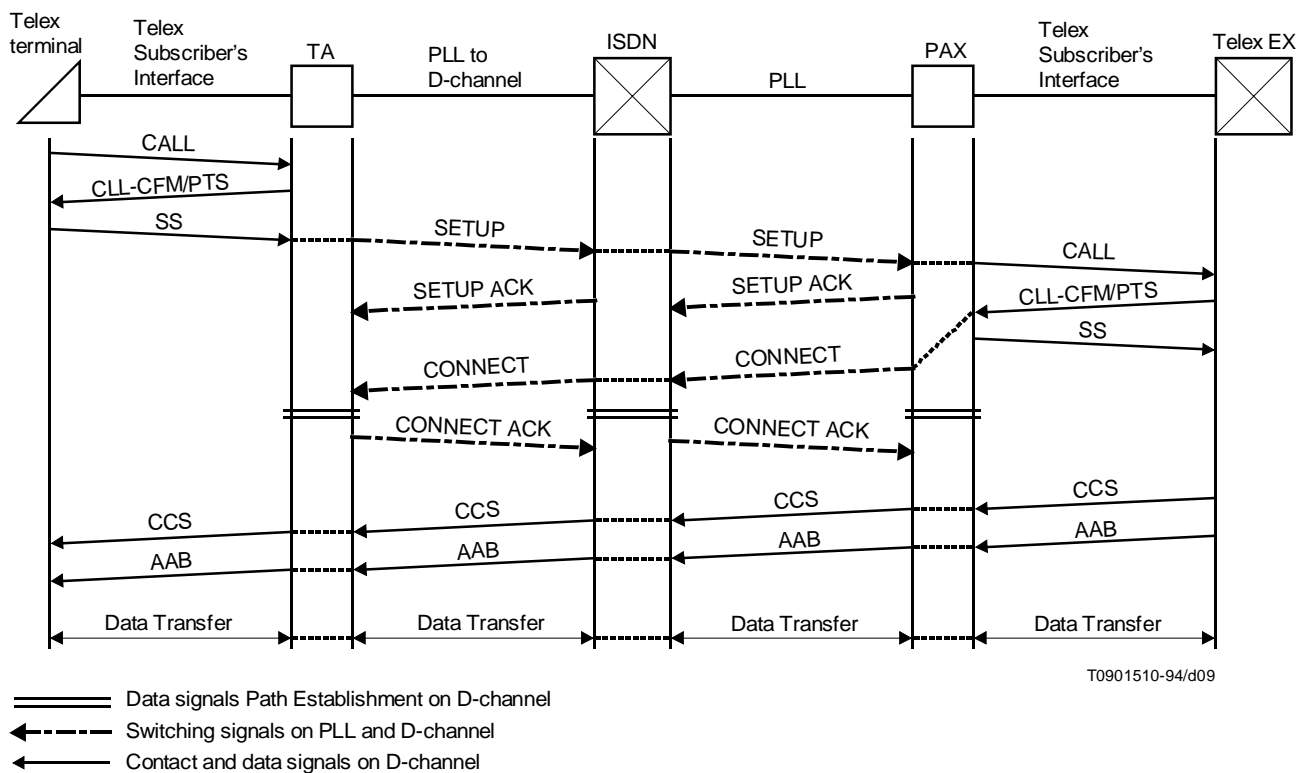

FIGURE 9/U.202  
 Call establishment sequence in the direction of an ISDN to a telex network  
 (minimum integration model)



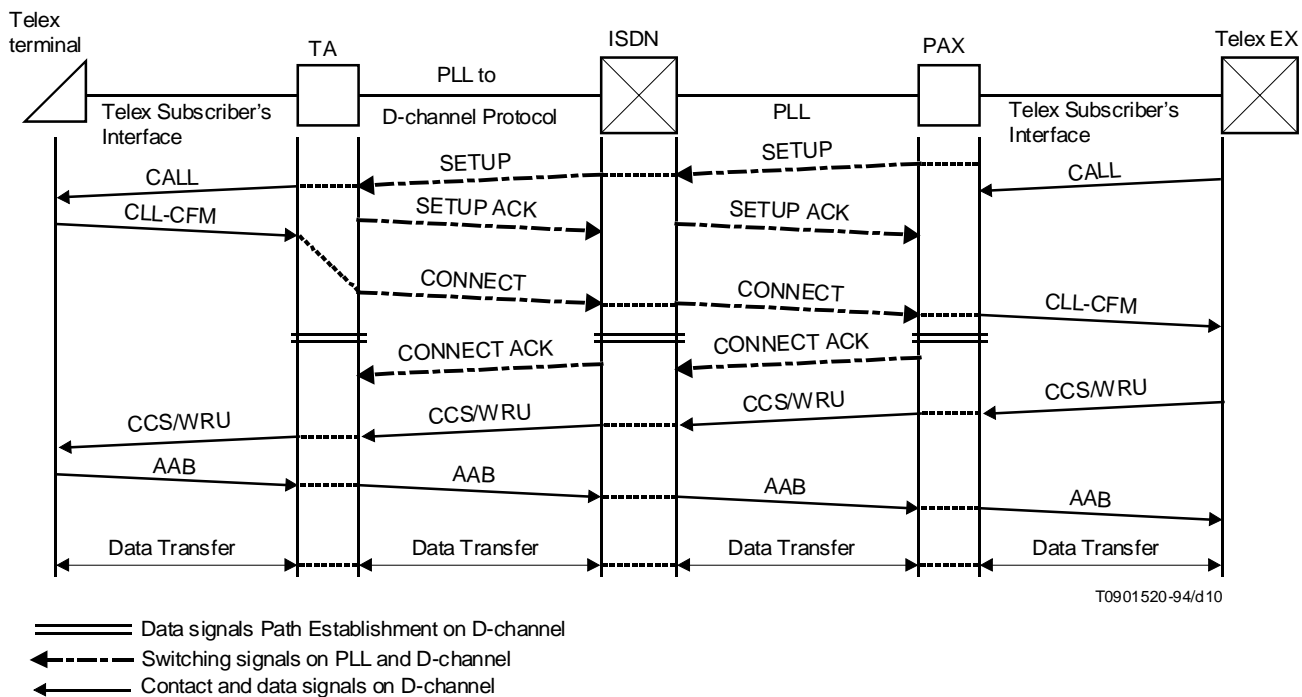
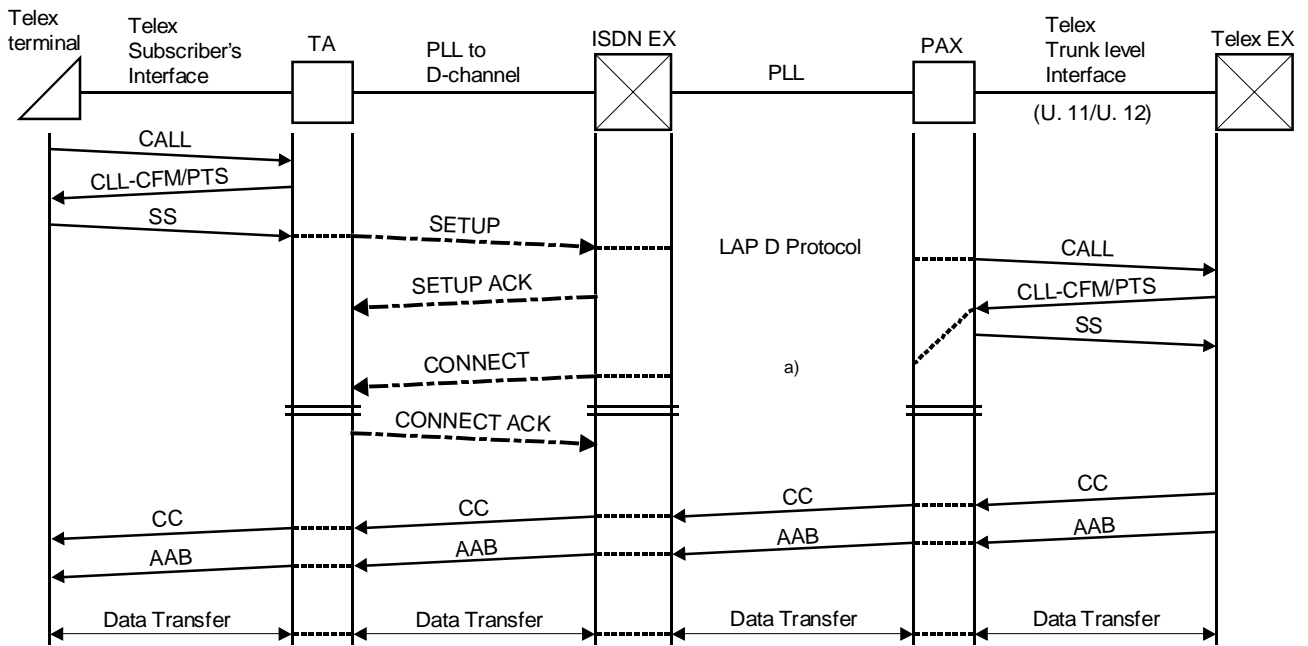

FIGURE 10/U.202  
 Call establishment sequence in the direction of a telex network to an ISDN  
 (minimum integration model)



T0901530-94/d11

- ==== Data signal Path Establishment on channel D
- ←--- Switching signals on PLL and D-channel
- ←--- Signals on D-channel

a) The details are for further study.

FIGURE 11/U.202  
**Call establishment sequence in the direction of ISDN to telex network  
 (integration with switching)**

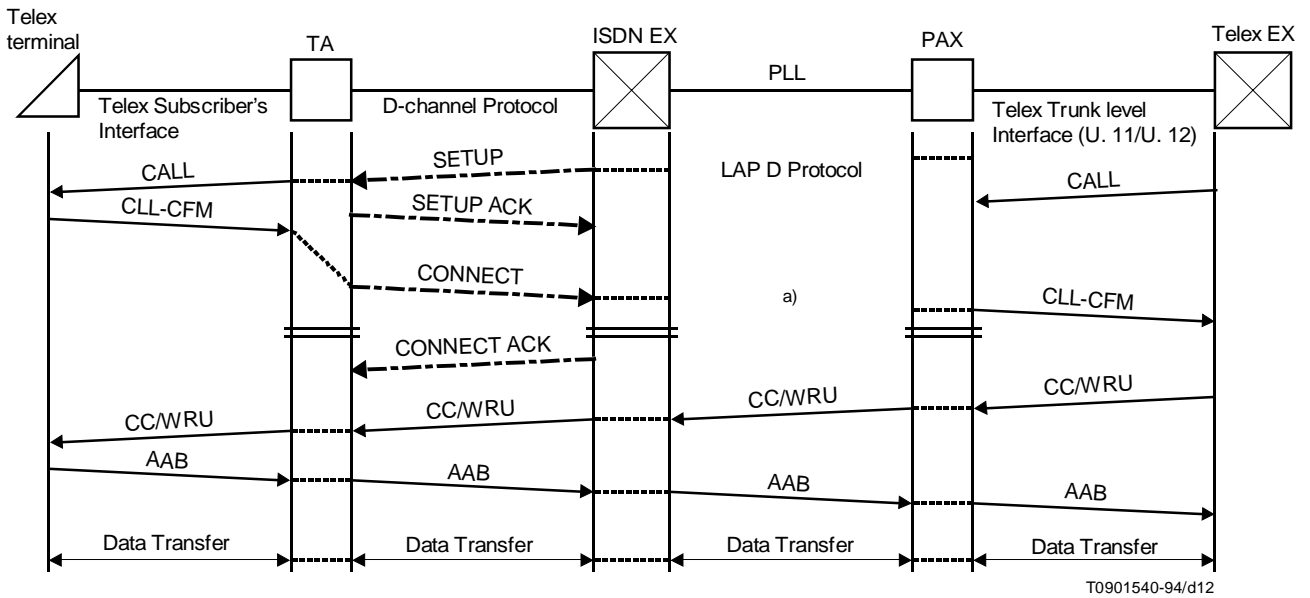

a) The details are for further study.

FIGURE 12/U.202  
**Call establishment sequence in the direction of telex network to ISDN  
(integration model with switching)**

## 7 Switching signalling conversion

The PAX associated with a telex exchange ensures the adapting function, by transforming the telex signals into X.25 packets, and vice versa.

The PAX shall therefore emulate the telex procedure for the ISDN.

The call, call confirmation, clear and clear confirmation signals are translated into X.25 packets for the establishment and clearing of virtual circuits; they cause the activation and deactivation of the PLL.

The number of the telex subscriber, called by an ISDN user, is transmitted as a whole by the terminal adaptor, in the form of an X.25 call packet. The sending of this packet is triggered by the reception of the signal + for end of selection.

Call connected signal (CCS), answerback, and date and time are also sent in the form of X.25 data packets, after which the exchange of telex messages can begin.

Service signals emitted by the telex to a subscriber on the ISDN should also be retransmitted in the form of X.25 packets.

The signal sequences are shown in Figures 9, 10, 11 and 12 for the establishment of a communication from ISDN to telex, and telex to ISDN, respectively.

The indications given above also apply to the case of access to the PAX on the subscriber line (minimum integration) and to the case of access at circuit level (maximum integration).

## 8 Conversion of telex message characters

The conversion of telex characters into X.25 packets and vice versa should be carried out:

- i) on the terminal side, connected to the ISDN, by the terminal adaptor (TA);
- ii) on the telex network side, by the telex access point (PAX).

For the method of packeting telex characters, the following rules are recommended:

Every telex character is transmitted in an octet; the three remaining bits, which are heavily weighted, are coded zero.

The systematic sending of a packet per character is to be avoided, since it can saturate the D-channel for telex and also render it unusable for other functions. This method is also uneconomical, considering that X.25 packets are made up of 128 useful octets.

In order to avoid having to transmit one packet per character, the following method is recommended: The characters received since the sending of the preceding packet are recorded, until a new packet is sent, which is triggered by the occurrence of any one of the following events:

- a) detection of a carriage return character;
- b) extension of the 30 ms stop which normally ends a telex character, by a Z state lasting at least 50 ms;
- c) number of recorded characters reaching a set maximum, which will not be less than 20 characters;
- d) detection of a WRU signal or a bell (figure shift followed by D or J);
- e) reception of an answerback in response to a transmitted WRU signal.

NOTE – The effect of rule a) is that, in automatic telex transmission, which is the most frequent case, a packet is initiated for each new line of printed characters.

In particular, the answerback will, by necessity, be transmitted in a single packet and will never be split, so long as the rule on answerback composition is observed (i.e., that printed characters cannot be preceded by carriage return characters).

The effect of rule b) is that any interruption, however short, in the automatic transmission or a break in manual transmission will trigger the sending of the packet of recorded characters, even incomplete, which allows the use of conversational mode.

## 9 Recapitulation

Both terminal adaptor and telex access point should be able to carry out packeting and unpacketing conversions of telex characters, at the ISDN/telex and ISDN/terminal interfaces.

The telex access point should also be able to

- interpret telex exchange signals and give appropriate replies if necessary;
- apply the interconnection procedure, if it is not applied by another telex exchange;
- convert telex numbers into ISDN numbers and vice versa.

### Legend to Figures 3, 4, 5, 6, 7 and 8:

CALL	Calling signal
CLL-CFM	Call confirmation signal
SS	Selection signal
CC	Call connected signal
AAB	Automatic answerback signal
WRU	☒ (Who are you?) signal
CLR-CFM	Clear confirmation signal
CLR	Clearing signal
SETUP	Setup message
SETUP ACK	Setup acknowledgement message
CONNECT	Connect message
CONNECT ACK	Connect acknowledgement message
TA	Terminal adaptor
PAX	Telex access point
EX	Exchange
PLL	Permanent logical link