



INTERNATIONAL TELECOMMUNICATION UNION

**ITU-T**

TELECOMMUNICATION  
STANDARDIZATION SECTOR  
OF ITU

**U.101**

(03/93)

**TELEGRAPH SWITCHING  
INTEX SERVICE**

---

**SIGNALLING SYSTEMS  
FOR THE INTEX SERVICE  
(TYPES E AND F SIGNALLING)**

**ITU-T Recommendation U.101**

(Previously "CCITT Recommendation")

---

## FOREWORD

The ITU Telecommunication Standardization Sector (ITU-T) is a permanent organ of the International Telecommunication Union. The ITU-T is responsible for studying technical, operating and tariff questions and issuing Recommendations on them with a view to standardizing telecommunications on a worldwide basis.

The World Telecommunication Standardization Conference (WTSC), which meets every four years, established the topics for study by the ITU-T Study Groups which, in their turn, produce Recommendations on these topics.

ITU-T Recommendation U.101 was prepared by the ITU-T Study Group IX (1988-1993) and was approved by the WTSC (Helsinki, March 1-12, 1993).

---

## NOTES

1 As a consequence of a reform process within the International Telecommunication Union (ITU), the CCITT ceased to exist as of 28 February 1993. In its place, the ITU Telecommunication Standardization Sector (ITU-T) was created as of 1 March 1993. Similarly, in this reform process, the CCIR and the IFRB have been replaced by the Radiocommunication Sector.

In order not to delay publication of this Recommendation, no change has been made in the text to references containing the acronyms "CCITT, CCIR or IFRB" or their associated entities such as Plenary Assembly, Secretariat, etc. Future editions of this Recommendation will contain the proper terminology related to the new ITU structure.

2 In this Recommendation, the expression "Administration" is used for conciseness to indicate both a telecommunication administration and a recognized operating agency.

© ITU 1994

All rights reserved. No part of this publication may be reproduced or utilized in any form or by any means, electronic or mechanical, including photocopying and microfilm, without permission in writing from the ITU.

## CONTENTS

	<i>Page</i>
1 Type E signalling .....	1
2 Type F signalling.....	25
3 Interworking between Types E and F signalling.....	27



**SIGNALLING SYSTEMS FOR THE INTEX SERVICE  
TYPES E AND F SIGNALLING)**

*(Helsinki, 1993)*

The CCITT,

*considering*

- (a) that new networks are being introduced based upon stored program control techniques;
- (b) that these networks as well as being able to carry the International Telex Service, can also carry the Intex service using alphabets other than the International Telegraph Alphabet No. 2 and that interworking between these services is essential;
- (c) that the equipment provided for these networks supports an enhanced range of facilities but that for speed and ease of introduction of the Intex service some Administrations may wish not to offer these enhanced facilities at the outset;
- (d) that the Intex service requires the establishment of new types of signalling, and these signalling types shall permit interworking between Intex terminals, between telex terminals and Intex terminals, and between telex terminals and terminals capable of operating both telex and Intex dual service terminals;
- (e) that Recommendation S.33 defines the alphabet and presentation characteristics for Intex;
- (f) that Recommendation U.210 defines the network interworking requirements between the International Telex Service and the Intex service;
- (g) that Recommendation S.34 describes Intex terminal requirements to effect interworking with the International Telex Service;
- (h) that Recommendation S.35 defines the composition of answerbacks for the Intex service;
- (i) that Recommendation F.150 defines the operational and service requirements of the Intex service;
- (j) that Recommendation F.82 defines the operational and service requirements for interworking between the Intex service and the International Telex Service;

NOTE – The development in the future of services similar to Intex may occur. It may be possible that some of the provisions of this Recommendation should be applied to such services.

*unanimously declares the view*

- (1) that to support a full range of enhanced customer facilities, Type E signalling as described in clause 1, shall be adopted on trunks between switching centres,
- (2) that where an Administration does not wish to offer a full range of enhanced customer facilities Type F signalling as described in clause 2 may be adopted on trunks between switching centres,
- (3) interworking between Types E and F signalling is for further study (see clause 3).

## **1 Type E signalling**

### **1.1 General switching and signalling principles**

**1.1.1** Type E signalling is independent of the speed and code conversion method and may be used over synchronous or asynchronous channels. Decentralized signalling shall apply with the same channel being used for control signalling and information transfer.

**1.1.2** Both terminal and transit operation shall be supported. Due to the inclusion of transit operation, link-by-link signalling control of calls shall be adopted.

**1.1.3** Onward selection from transit and incoming terminal centres shall be arranged to overlap the reception of selection signals in order to minimize call set-up times. Selection signals shall be transmitted by the originating centre at automatic speed in a single block that includes an end of selection signal.

**1.1.4** The schedule of telex destination codes detailed in Recommendation F.69 shall apply. The same numerical codes shall be used for network identification purposes.

**1.1.5** Alternative routing shall be permitted but shall be restricted in order to prevent repeated alternative routing causing traffic to circulate. Alternative routing shall therefore be allowed only once in the originating network, once during international routing between the originating and terminal networks, and once in the terminal network.

**1.1.6** Both-way operation shall be assumed. In order to minimize head-on collisions inverse order testing of circuits shall be used. Also allowed is a close approximation to inverse order testing whereby the route is tested in small groups in fixed order always starting the search from the same position.

**1.1.7** Normally the originating network shall be responsible for recording accounting information. The recording of accounting information by other than the originating network is for further study.

**1.1.8** The Grade of Service for the provision of circuits shall not be worse than one lost call in 500.

**1.1.9** Operation of switching equipment shall be such that congestion shall not be signalled on more than 0.2% of calls in the busy hour, and only when congestion has been positively identified.

## **1.2 Specific signalling characteristics**

Notes applicable to 1.2

### NOTES

1 X denotes the international centre that originates the call under consideration on the international link concerned. Y denotes the international centre that receives the call under consideration on the international link.

Centre X and centre Y shall provide any necessary signalling conversion (including speed/code conversion) to the type of signalling employed on the preceding and succeeding links if these do not use Type E signalling.

2 Timings shown are within the centre concerned with no allowance being made for propagation and other delays.

3 The times for permanent start polarity (A) and stop polarity (Z) are generally indicated in the following signal descriptions as integral multiples of the duration of a character.

4 The control signalling code (CSC) used in this signalling system is described in Table 8.

**1.2.1** The signalling system for higher baud rate services between two anisochronous networks using Type E signalling is detailed in Table 1.

**1.2.2** On incoming calls, if the duration of the calling signal exceeds two character periods (or four character periods in exceptional cases where extension of call signals has been requested by centre Y) start polarity shall be maintained on the backward signalling path from centre Y to centre X. This will cause the connection to be released by centre X.

**1.2.3** The first forward path signal following the calling signal (class-of-traffic signal) is distinctive from the first backward path signal to provide positive detection of head-on collisions on bothway circuits. A head-on collision is indicated by the reception of a first class-of-traffic character instead of the reception confirmation or reception congestion signal.

When a head-on collision is detected, the switching centres at each end of the circuit shall make another attempt to select a free circuit, either on the same group of circuits or on an alternative route if one exists and alternative routing is permitted. If no free circuit is found, or if a further head-on collision is detected, the call shall be cleared. At transit centres call progress signal 20 shall be transmitted immediately before the clearing signal but after the reception confirmation signal and the network identification signal (if any).

**1.2.4** If no reception confirmation or reception congestion signal is received within four seconds from the start of the calling signal, and no head-on collision has been detected, the call shall be cleared, the circuit shall be marked unavailable for outgoing traffic and the automatic retest procedure shall be applied to the circuit concerned.

**1.2.5** Selection signals are divided into two parts. The first part, designated as network selection signals, contains information regarding network and customer requirements and may comprise one or more characters (see Tables 2, 3, 3a, 4, 4a and 5). The second part comprises address signals (the called customer number, preceded by the telex destination code on transit calls). The network selection signals are subdivided and assembled as described in 1.2.5.1 to 1.2.5.4 below for signalling purposes.

#### **1.2.5.1 First class-of-traffic character** (see Table 2)

The calling signal shall always be followed by at least one class-of-traffic character. The bit functions of this character are chosen so that no further network selection characters are required on the majority of calls. Whether a second class-of-traffic character or a user-class character follows is indicated by bits b3 and b4 of the first class-of-traffic character.

Bit b1 of the first class-of-traffic indicates whether or not the address selection signals include a telex destination code.

Bit b2 of the first class-of-traffic is used to indicate whether or not the call may be subjected to alternative routing, see 1.1.5.

#### **1.2.5.2 User-class characters** (see Tables 3 and 3a)

These characters, if used, shall follow the first class-of-traffic character and will be required when, for example, the information needed to be signalled cannot be derived from the incoming circuit.

Bit b4 of the first user-class character is used to indicate whether or not a second class-of-traffic signal follows.

#### **1.2.5.3 Second and third class-of-traffic characters** (see Tables 4 and 4a)

These characters, when used, shall follow either any user-class characters required, or when no user-class character is transmitted, the first class-of-traffic character.

The number of class-of-traffic characters depends on the number of facilities available. Bit b4 of the second and subsequent class-of-traffic characters shall indicate whether a further class-of-traffic character follows.

Bit b1 of the second class-of-traffic character shall indicate whether a call originates on a Type 1 or Type 2 network as defined in Recommendation U.201.

#### **1.2.5.4 User group sequence**

A user group sequence, if required, shall follow after all class-of-traffic and user-class characters. Bit b3 of the second class-of-traffic character shall indicate whether or not a user group sequence is included in the network selection.

The user group sequence shall comprise a start of user group character (see Table 5) followed by 1 to 8 hexadecimally coded user group characters.

NOTE – The significance of the user group sequence is for further study.

#### **1.2.5.5 Address selection characters**

The numerical characters used for the address selection signals are detailed in Table 6. The first class-of-traffic character shall indicate whether or not this address selection includes a telex destination code.

#### **1.2.5.6 End of selection character**

The address selection signals shall be terminated by an end of selection character comprising IA5 character 2/11.

### **1.2.6 Invalid selection signals received**

If the first character received after detection of a calling signal is not a valid first class-of-traffic character, or has parity error, the incoming switching centre shall maintain start polarity on the backward signalling path.

If any network selection signal after the first class-of-traffic character is not valid or has incorrect parity, or if any address selection character is received with incorrect parity, the incoming switching centre shall transmit call progress signal 20 followed immediately by a clearing signal.

If the end of selection signal is not received within 15 seconds from reception of the first class-of-traffic character, or if more than ten seconds elapses between consecutive selection characters, the incoming switching centre shall transmit call progress signal 20 followed immediately by a clearing signal.

The call progress signal shall be transmitted after the reception confirmation signal and network identification signal (if any).

**1.2.7** The maximum number of address selection characters to be expected is 18.

**1.2.8** If the reception congestion signal is received at a transit centre, that transit centre shall transmit call progress signal 61 followed immediately by a clearing signal to the preceding centre.

The call progress signal shall be transmitted after the reception confirmation signal and network identification signal (if any).

### **1.2.9 Network identification signals**

On calls incoming from international circuits the network identification signal shall be transmitted after the reception confirmation signal.

Network identification signals may be omitted by switching centres within a single network.

NOTE – The nature of network identification signals to be transmitted from switching centres within a network is for further study.

If several international centres are involved in the establishment of a call, the originating network will receive network identification signals one after another.

If, at an international transit centre, the first character of a network identification signal is not received within two seconds of the reception confirmation signal, the incoming switching centre shall transmit call progress signal 20 followed immediately by a clearing signal to the preceding centre.

It is possible for a transit centre to receive backward path signals such as network identification signals, a call connected signal or a call progress signals from subsequent centres whilst the backward path signals originated locally are still being sent. A transit centre shall ensure that the received signals are retransmitted without mutilation or loss. This can be ensured if seizure of an outgoing circuit is delayed until after complete transmission of the reception confirmation signal.

**1.2.10** The backward path signals indicating effective and ineffective call conditions are scheduled in Tables 7, 7a and 7b.

**1.2.11** If a call connected signal or start of transit through connect signal is not received within 125 seconds from transmission of the end of selection signal the call shall be cleared after transmission of service signal NC or call progress signal 20 as appropriate to the signalling on the calling circuit.

### **1.2.12 Connect through procedure**

#### **1.2.12.1 Connect through procedure at the terminating Type E centre**

When no non-clearing call progress signals are to be transmitted the terminating Type E centre shall transmit a call connected signal to the calling circuit after reception of a call connected signal.



If non-clearing call progress signal(s) are required to be transmitted the terminating Type E centre shall transmit a start of transit through connect signal (STTC) followed by a transit through connect signal (TTC), (see Tables 7 and 7a) to the calling circuit after reception of a call connected signal from the called circuit. Upon detection of a transit centre through connected (TTD) signal (see Table 6) on the forward signalling path the terminating centre shall transmit the non-clearing call progress signal(s), followed by a call connected signal, to the calling circuit.

After transmission of the call connected signal the terminating Type E centre shall establish the call by connecting through the forward and backward signalling paths.

### **1.2.12.2 Connect through procedure at transit Type E centres**

**1.2.12.2.1** When no non-clearing call progress signals are required to be generated by the transit centre, all CSC signals received from the called circuit shall be transferred to the calling circuit and vice-versa. Upon detection and transfer of a call connected signal the transit Type E centre shall establish the call by connecting through the forward and backward signalling paths.

**1.2.12.2.2** On calls where the transit Type E centre is required to generate one or more non-clearing call progress signals the transit Type E centre shall monitor the backward signalling path for a start of transit through connect/transit through connect (STTC/TTC) and call connected signals.

**1.2.12.2.2.1** If a call connected signal but no STTC/TTC signal is received, the transit Type E centre shall transmit a STTC/TTC signal on the backward signalling path of the calling circuit, and then monitor the forward signalling path from the calling circuit for a transit centre through connected signal (TTD).

When the TTD signal is received it shall be absorbed by the transit Type E centre. Upon detection of the TTD signal the transit centre shall transmit the non-clearing call progress signal(s) on the backward signalling path of the calling circuit. After transmission of the call progress signals the transit centre shall transmit a call connected signal to the calling circuit and establish the call by connecting through the forward and backward signalling paths. The call connected signal transmitted shall correspond to that received and absorbed from the called circuit.

**1.2.12.2.2.2** If a STTC/TTC signal is received from the called circuit the transit Type E centre shall forward this signal to the calling circuit. After the STTC/TTC signal has been forwarded any CSC characters received from the calling circuit shall be transferred to the called circuit.

The transit Type E centre shall then operate in one of the two ways described below:

- a) After transfer to the calling circuit of the STTC/TTC signals any subsequent backward path signals, except a call connected signal, shall be transferred to the calling circuit. The call connected signal received from the called circuit shall be absorbed by the transit Type E centre.

Upon detection of a call connected signal from the called circuit the transit Type E centre shall transmit its non-clearing call progress signal(s) on the backward signalling path of the calling circuit.

After transmission of the call progress signals the transit Type E centre shall transmit a call connected signal to the calling circuit and establish the call by connecting through the forward and backward signalling paths. The call connected signal transmitted shall correspond to that received and absorbed from the called circuit.

- b) After transfer to the calling circuit of the STTC/TTC signals any subsequent backward path signals, shall be absorbed and stored by the transit Type E centre.

Upon detection of a transit through connected signal from the calling circuit (and transfer of this signal to the called circuit) the transit Type E centre shall transmit its non-clearing call progress signal(s) on the backward signalling path of the calling circuit.

After transmission of the call progress signals the transit Type E centre shall retransmit from store (on the backward signalling path of the calling circuit) any characters which have been received and absorbed from the called circuit.

After completion of transmission of these stored characters the transit Type E centre shall establish the call by connecting through the forward and backward signalling paths.

### **1.2.12.2.3 Connect through procedure at originating Type E centres**

If a STTC/TTC signal is received from the called circuit the originating Type E centre shall transmit a TTD signal on the forward signalling path. Any non-clearing call progress signals received shall be absorbed.

#### **1.2.12.2.3.1 Originating centre in a Type 1 network** (see Recommendation U.210)

Upon reception of a call connected signal the originating Type E centre shall transmit an ENQ character (WRU signal) on the forward signalling path.

After reception of the called customers answerback and transfer to the calling circuit the originating Type E centre shall transmit a Speed Indicator character sequence to both the calling and called circuits. Transmission of the Speed Indicator sequence shall commence two character periods from the end of the called customer answerback.

The Speed Indicator sequence transmitted shall be that appropriate to the speed of the calling terminal unless, on mixed speed calls, the called terminal operates at a lower speed (as determined from the outgoing circuit or by reception of the appropriate non-clearing call progress signal). In such cases the Speed Indicator sequence transmitted shall be that appropriate to the speed of the called terminal.

No Speed Indicator sequence shall be transmitted on calls which have been routed to the International Telex Service as determined by either the outgoing circuit seized or reception of non-clearing call progress signal 91.

The format of Speed Indicator sequences is shown in Table 9.

#### **1.2.12.2.3.2 Originating centre in a Type 2 network** (see Recommendation U.210)

Upon reception of a call connected signal the originating centre shall transmit an ENQ character (WRU signal) on the forward signalling path unless non-clearing call progress signal 91 has been received indicating connection to the International Telex Service.

If non-clearing service signal 91 is received the originating centre shall transmit a Telex Indicator signal (IA5 character 5/1) to the calling customer line.

Within 33 milliseconds of transmission of the Telex Indicator signal the switching centre shall be able to transmit and receive ITA2 characters at a nominal modulation rate 50 baud on both the calling and called circuits as detailed in Recommendation U.210, clause 2.

The originating switching centre shall transmit the ITA2 character sequence 30, 4 (WRU signal) to the called circuit commencing between 100 and 150 milliseconds after the end of transmission of the Telex Indicator signal.

**1.2.13** The reception of a call connected signal confirms that the call is extended to the called customer's line.

**1.2.14** Complete network through connection is assured when the called terminal's answerback is received by the calling terminal.

**1.2.15** The guard delays on clearing are measured from the moment when start polarity has been established on both signalling paths by

- either recognizing or transmitting the clearing signal on one signalling path; and
- either transmitting or recognizing the clear confirmation signal on the other signalling path.

The guard delay for incoming calls shall be 150-600 milliseconds. A new call shall not be accepted until this guard delay has elapsed.

The guard delay for outgoing calls shall be 450-1000 milliseconds greater than the guard delay for incoming calls.

After expiry of the guard delay the circuit shall be restored to the free line condition.

**1.2.16 The automatic retest procedure shall be initiated as indicated in 1.2.4 above.**

The circuit shall be tested up to five times at nominal intervals of 1.0 or 1.2 minutes and a check made for a reception confirmation signal in response to each test. If a valid reception confirmation has not been received at the end of this first group of tests, the retest shall continue with a further group of up to five tests at either 5.0/6.0 or 30/36 minute intervals. If 5.0 or 6.0 minute intervals are used and a valid reception confirmation signal has not been received at the end of this second group of tests, a further group of up to nominally five retests shall be made at 30 or 36 minute intervals. An alarm shall be given at an appropriate time. However the retest procedure may be discontinued at any stage at the discretion of the outgoing Administration.

If during the sequence of retests a valid reception confirmation signal is detected, a clearing signal shall be transmitted in place of the retest signal. Following reception of a clear confirmation signal the circuit shall be restored to service after expiry of the appropriate guard delay. To cater for the possibility that a faulty circuit may be seized at both ends switching centres should allow an incoming call to be received during the start polarity period of the retest signal. Such calls may however be ignored during the incoming guard delay period.

The intervals between the tests at the two ends of the circuit shall be made different to be sure that successive retests do not overlap at both ends. In general the international centre having the higher telex destination code shall take the longer retest interval (i.e. 1.2, 6.0 and 36 minutes).

The tolerance on all retest timings shall be  $\pm 10\%$ .

The use of a special first class-of-traffic character for retest enables an incoming centre to be aware of retests being applied to its incoming circuits.

**1.2.17 Signalling diagrams**

Details of Types E and F signalling are shown in Figures 1 to 8. These diagrams cover the cases of calls between Intex customers or calls to telex customers.

TABLE 1/U.101

**Type E signalling for anisochronous networks**

Signal or function	Forward path (X towards Y)	Backward path (Y towards X)	Remarks
Free line	Start polarity (polarity A)	Start polarity (polarity A)	
Call	Stop polarity (polarity Z) for a minimum period of one character and a maximum of two characters followed immediately by selection signs		The equipment at centre Y must be connected and ready to receive selection signals within one character period.  Exceptionally the minimum and consequently the maximum period may be lengthened to no more than four characters at the request of the incoming country (Y).
Reception-confirmation		Stop polarity followed by IA5 character 2/10	Stop polarity returned within three character periods after the end of receipt of the first class-of-traffic signals.  The return of IA5 character 2/10 shall commence within one to two character periods after the inversion to stop polarity.  The reception-confirmation signal will have to be absorbed by the switching equipment of X and should not be able to go through that equipment to arrive at the preceding centre.

TABLE 1/U.101 (cont.)

Signal or function	Forward path (X towards Y)	Backward path (Y towards X)	Remarks
Selection	At least one (first class-of-traffic signal only) or possibly several network selection signals depending on the network requirement (Appendix I), the two or three digits of the F.69 telex destination code of the called country, the digits of the called station number and an end-of-selection signal IA5 Character 2/11.		These signals are transmitted immediately after the calling signal without awaiting the reception at X of the reception-confirmation signal.  The destination code will be omitted for terminal calls.  The selection signal will be transmitted in a single group at automatic speed.
Network identification		CSC No. 12 followed by the F.69 code for the network concerned	The CSC No. 12 follows the reception confirmation signal at automatic speed after one to two character periods. These signals must go through centre X and arrive at the originating centre.  Need not be transmitted on calls within a single network.
Reception-congestion		Stop polarity for a period of one or two characters followed by the clearing signal	When selection signals cannot be accepted (see 1.9) this signal should be returned as soon as possible and in any event within three character periods (exceptionally five character periods where centre X sends prolonged call signals) after the start of receipt of the call signal.  The reception-congestion signal should be absorbed by centre X and not allowed to be received by a preceding centre.
Service signal without clearing		CSC characters (Table 7b) followed by the idle circuit condition	Service signals consists of CSC No. 11 followed by two characters from Table 7b.
Call connected		One CSC character (Table 7)	See Appendix III.
Start of transit through-connect signal (STTC)		CSC No. 15 (Table 7)	This signal always precedes the transit through-connect signal.
Transit through-connect signal (TTC)		One CSC character (Table 7a)	This signal will always be prefaced by the start of transit through-connect signal and will be returned preceding a service signal without clearing when this has to be sent.
Transit centres through-connected signal (TTD)	CSC No. 11 (see Table 6)		This signal will be transmitted within one to two character periods after the receipt of the transit through-connect signal (TTC).
Speed indicator	One of the sequences in Table 9 commencing one to two character periods after the called answerback	As for the forward path	
ENQ (WRU) (Who are you?)	WRU character IA5 character 1/5		
Service signal with clearing		CSC characters (Table 7b) followed by clearing signal	The service signal consists of CSC No. 11 followed by two characters of Table 7b.

TABLE 1/U.101 (end)

Signal or function	Forward path (X towards Y)	Backward path (Y towards X)	Remarks
Idle circuit	Stop polarity	Stop polarity	
Clearing	Continuous start polarity in the direction of clearing. The recognition time shall be in the range 240 to 490 ms.		
Clear confirmation	Continuous start polarity in the opposite direction commencing upon recognition of the clearing signal		
Incoming guard delay	A period 150-600 ms measured from the appearance of start polarity on both signalling paths		A new incoming call shall not be accepted until this guard period is elapsed. For further details see 2.15.
Outgoing guard delay	A period commencing from the appearance of start polarity on both signalling paths and continuing for 450 to 1000 ms longer than the incoming guard delay		The outgoing equipment should not open the trunk circuit for service until this guard period has elapsed. For further details see 2.15.
Automatic retest	Stop polarity for 1-2 (exceptionally 4) character periods followed by CSC No. 13 stop polarity for 4 seconds and then start polarity, repeated		For further details on the repetition periods see 2.16.
Backward busy		Continuous stop polarity for a maximum of 5 minutes	
NOTE – For the Control Signalling Code (CSC) numbers mentioned refer to Table 8.			

TABLE 2/U.101

**First Control Signalling Code (CSC) character on forward and backward signalling paths**

Combination				Condition signalled
b <sub>4</sub>	b <sub>3</sub>	b <sub>2</sub>	b <sub>1</sub>	
A	A			No further network selection signals follow <sup>a)</sup>
A	Z			Second class-of-traffic character follows without any user-class character <sup>a)</sup>
Z	A			User-class character follows (and possibly a second class-of-traffic character) <sup>a)</sup>
		A		Alternative routing not allowed <sup>a)</sup>
		Z		Alternative routing allowed <sup>a)</sup>
			A	Selection includes F.69 code <sup>a)</sup>
			Z	Selection does not include F.69 code <sup>a)</sup>
Z	Z	A	A	Retest signal <sup>a)</sup>
Z	Z	A	Z	Reception confirmation
Z	Z	Z		Not used <sup>a)</sup>
<sup>a)</sup> First class-of-traffic.				

TABLE 3/U.101

**First user-class character**

Combination				Condition signalled
b <sub>4</sub>	b <sub>3</sub>	b <sub>2</sub>	b <sub>1</sub>	
A				No second class-of-traffic character follows
Z				A second class-of-traffic character follows
	A			No second user-class character follows
	Z			Second user-class character follows
		A	A	Other speed (see 2nd or 3rd user-class character)
		A	Z	1200 bit/s
		Z	A	600 bit/s
		Z	Z	300 bit/s

TABLE 3a/U.101

**Second user-class character**

Combination				Condition signalled
b <sub>4</sub>	b <sub>3</sub>	b <sub>2</sub>	b <sub>1</sub>	
A				2400 bit/s
Z				Other speed (see 1st or 3rd user-class character)
	A			No third user-class character follows
	Z			Third user-class character follows
		A	A	Service category call
		A	Z	Customer category call
		Z	A	User group category call
		Z	Z	Reserved for national use

TABLE 4/U.101

**Second class-of-traffic character**

Combination				Condition signalled
b <sub>4</sub>	b <sub>3</sub>	b <sub>2</sub>	b <sub>1</sub>	
A				No third class-of-traffic character follows
Z				Third class-of-traffic character follows
	A			No user group sequence follows
	Z			User group sequence follows
		A		Not used
		Z		Not used
			A	Call originates on Type 1 network
			Z	Call originates on Type 2 network

TABLE 4a/U.101

**Third class-of-traffic character**

Combination				Condition signalled
b <sub>4</sub>	b <sub>3</sub>	b <sub>2</sub>	b <sub>1</sub>	
A				No fourth class-of-traffic character follows
Z				Fourth class-of-traffic character follows
	A			Not used
	Z			Not used
		A		Redirection allowed
		Z		Redirection not allowed
			A	Not used
			Z	Not used

TABLE 5/U.101

**Start of user group character**

Combination				Condition signalled
b <sub>4</sub>	b <sub>3</sub>	b <sub>2</sub>	b <sub>1</sub>	
A				Outgoing access not allowed
Z				Outgoing access allowed
	A	A	A	1 user group character follows
	A	A	Z	2 user group characters follow
	A	Z	A	3 user group characters follow
	A	Z	Z	4 user group characters follow
	Z	A	A	5 user group characters follow
	Z	A	Z	6 user group characters follow
	Z	Z	A	7 user group characters follow
	Z	Z	Z	8 user group characters follow

TABLE 6/U.101

**Miscellaneous forward path signals**

Combination				Condition signalled
b <sub>4</sub>	b <sub>3</sub>	b <sub>2</sub>	b <sub>1</sub>	
A	A	A	A	Digit 0
A	A	A	Z	Digit 1
A	A	Z	A	Digit 2
A	A	Z	Z	Digit 3
A	Z	A	A	Digit 4
A	Z	A	Z	Digit 5
A	Z	Z	A	Digit 6
A	Z	Z	Z	Digit 7
Z	A	A	A	Digit 8
Z	A	A	Z	Digit 9
Z	A	Z	A	Not used
Z	A	Z	Z	Transit Centres Through Connected (TTD) Signal
Z	Z			Not used

Digits for:

- F.69 Destination Code
- Called customers number
- User group address



TABLE 7/U.101

**Miscellaneous backward path signals**

Combination				Condition signalled	
b <sub>4</sub>	b <sub>3</sub>	b <sub>2</sub>	b <sub>1</sub>		
A	A	A	A	Digit 0	Digits for: – Call progress signal – Network identification signal
A	A	A	Z	Digit 1	
A	A	Z	A	Digit 2	
A	A	Z	Z	Digit 3	
A	Z	A	A	Digit 4	
A	Z	A	Z	Digit 5	
A	Z	Z	A	Digit 6	
A	Z	Z	Z	Digit 7	
Z	A	A	A	Digit 8	
Z	A	A	Z	Digit 9	
Z	A	Z	A	Start of Call Progress Signal	
Z	A	Z	Z	Not used	
Z	Z	A	A	Call connect signal – Chargeable call	
Z	Z	A	Z	Call connected signal – Non-chargeable call	
Z	Z	Z	A	Start of Transit Through Connect Signal	
Z	Z	Z	Z	Not used	

TABLE 7a/U.101

**Transit through-connect signals**

Combination				Condition signalled	
b <sub>4</sub>	b <sub>3</sub>	b <sub>2</sub>	b <sub>1</sub>		
A	A			Not used	
A	Z			Not used	
Z	A			Not used	
Z	Z	A		Transit through-connect signal (TTC)	
			A	Chargeable call	
			Z	Non-chargeable call	
Z	Z	Z		Not used	

TABLE 7b/U.101

**Call progress signals**

Numerical code	Category	Meaning	Equivalent printing service signal
20	With clearing	Network Failure	NC
21		Number Busy	OCC
41		Access Barred	NA
42		Changed Number	NCH
43		Not Obtainable	NP
44		Out of Order	DER
45		Customer Absent	ABS
61		Network Congestion	NC
75		Change Speed	None
80		With clearing or redirection	Changed number followed by new number
02	Without clearing	Redirected Call	None
91	Without clearing	Speed and code conversion to the International Telex Service	None
92		Adjust speed to 300 bit/s	None
93		Adjust speed to 600 bit/s	None
94		Adjust speed to 1200 bit/s	None
95	Without clearing	Called terminal inviolate to priority interruption	None

TABLE 8/U.101

**Control signal code (CSC) table**

CSC character number	CSC character structure				
	b <sub>8</sub>	b <sub>4</sub>	b <sub>3</sub>	b <sub>2</sub>	b <sub>1</sub>
1	A	A	A	A	A
2	Z	A	A	A	Z
3	Z	A	A	Z	A
4	A	A	A	Z	Z
5	Z	A	Z	A	A
6	A	A	Z	A	Z
7	A	A	Z	Z	A
8	Z	A	Z	Z	Z
9	Z	Z	A	A	A
10	A	Z	A	A	Z
11	A	Z	A	Z	A
12	Z	Z	A	Z	Z
13	A	Z	Z	A	A
14	Z	Z	Z	A	Z
15	Z	Z	Z	Z	A
16	A	Z	Z	Z	Z

**NOTES**

1 Bits 1-4: Information elements

Bits 5-7: ZZA

Bit 8: Parity check element

2 The 7-unit code with one parity element and single-unit start and nominal 1-unit stop element used in this control signalling system is listed in this table.

3 The parity element shall correspond to even parity with regard to elements of Z polarity. The individual elements shall be transmitted at the nominal modulation rate with the low order (i.e. b<sub>1</sub>) first and completed by the parity element (b<sub>8</sub>).

TABLE 9/U.101

**Speed indicator sequences**

Speed indicator sequence number	Character structure				Significance
	1	2	3	4	
1	1/11	1/3	1/2	1/1	300 bit/s character rate call
2	1/11	1/3	1/7	1/1	600 bit/s character rate call
3	1/11	1/3	1/8	1/1	1200 bit/s character rate call
4	1/11	1/3	1/13	1/1	2400 bit/s character rate call

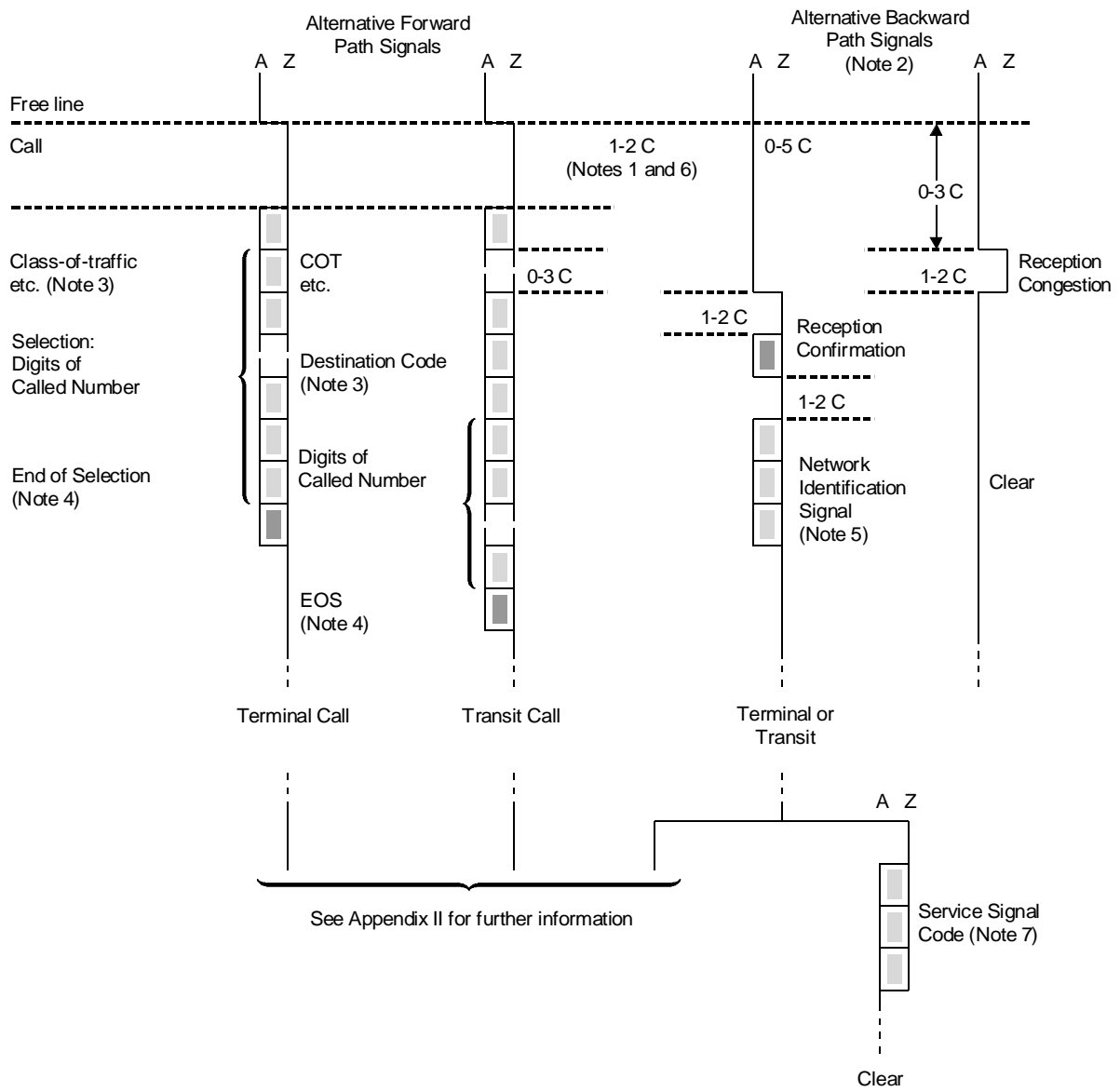

T0900720-91/d01

NOTE – The Notes to Figures 1 to 7 can be found at the end of Figure 7.

FIGURE 1/U.101  
**Signalling System Type E**

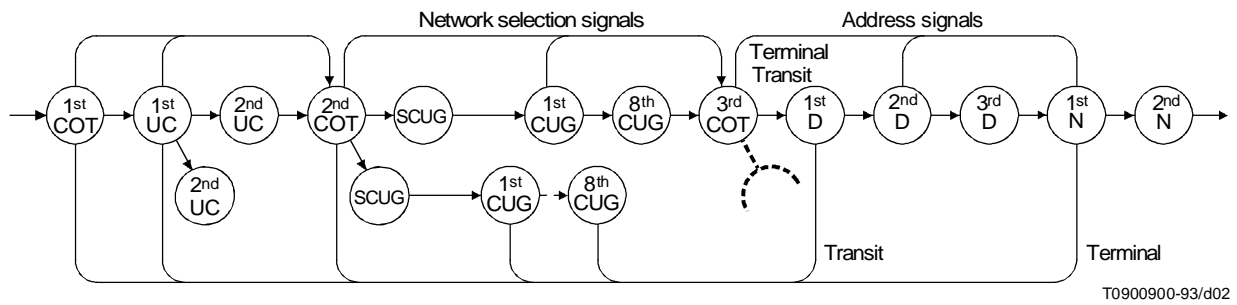

T0900900-93/d02

- COT Class-of-traffic character
- UC User-class character
- SCUG Start of closed user group sequence
- CUG Closed user group character
- D Destination code digit
- N Called number digit

NOTE – Dotted lines reserved for further extension.

FIGURE 2/U.101  
Possible sequences of network selection signals

Signalling System Type E  
Through-connection procedure

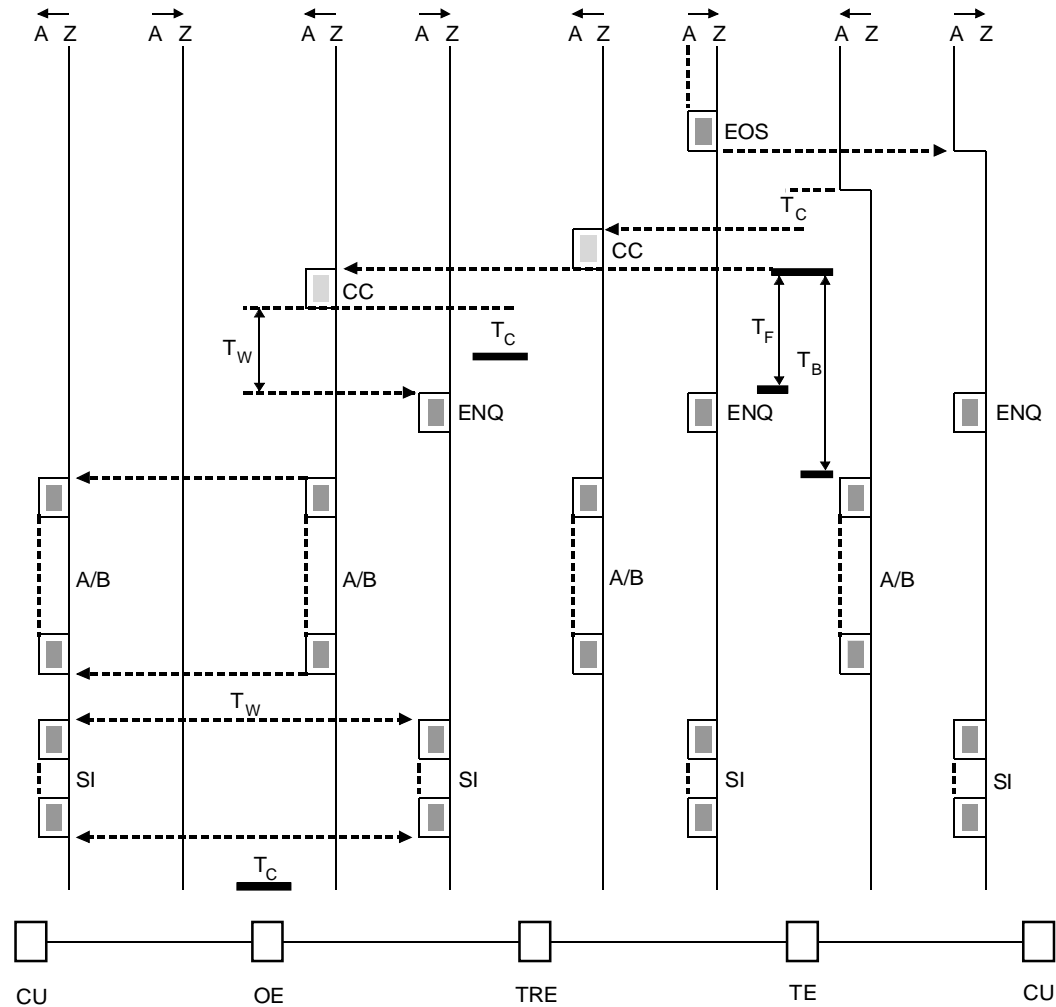

T0900730-91/d03

Legends to Figures 3-7:

	Correlation line	CP	Call progress signal
	Through-connection	CC	Call connected signal
	Upper and lower limits for through-connection of backward path	ENQ	IA5 Character 05 (WRU)
	Upper and lower limits for through-connection of forward path	A/B	Answerback
	IA5/ITA2 Character (see Note 8)	SI	Speed indicator
	CSC character	TI	Telex indicator
EOS	End of selection signal	CU	Customer
STTC	Start of transit through-connect	OE	Originating exchange
TTC	Transit through-connect	TRE	Transit exchange
TTD	Transit centres through-connected	TE	Terminating exchange
		CUT	Telex customer
		T <sub>C</sub>	0 to 1 character period
		T <sub>W</sub>	1 to 2 character periods

FIGURE 3/U.101

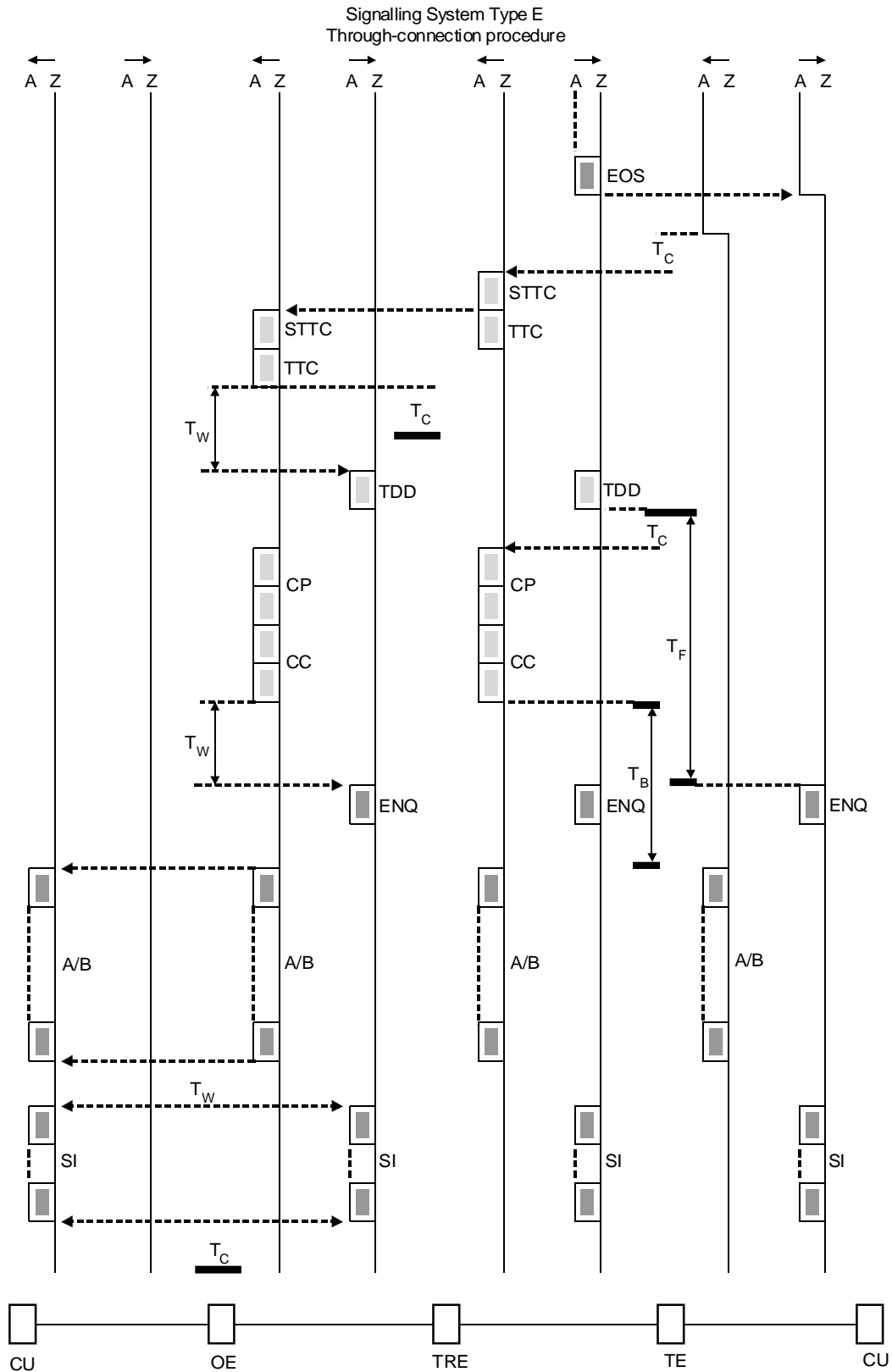

T0900750-91/d04

FIGURE 4/U.101  
Call progress signal without clearing  
(e.g. redirected call)  
generated at transit Exchange

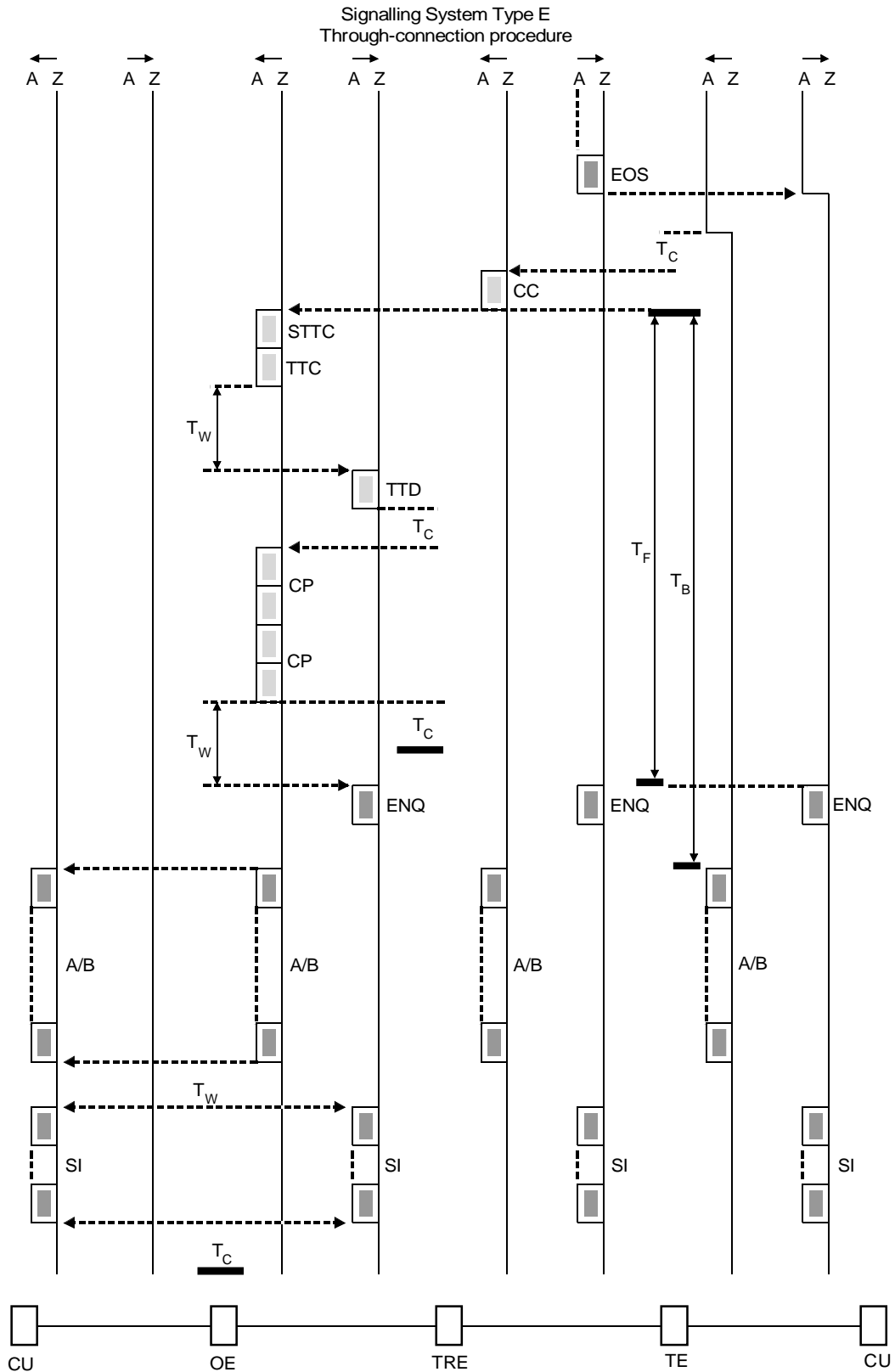

T0900740-91d05

FIGURE 5/U.101  
Call progress signal without clearing  
(e.g. redirected call)  
generated at transit Exchange



Signalling System Type E  
Through-connection procedure

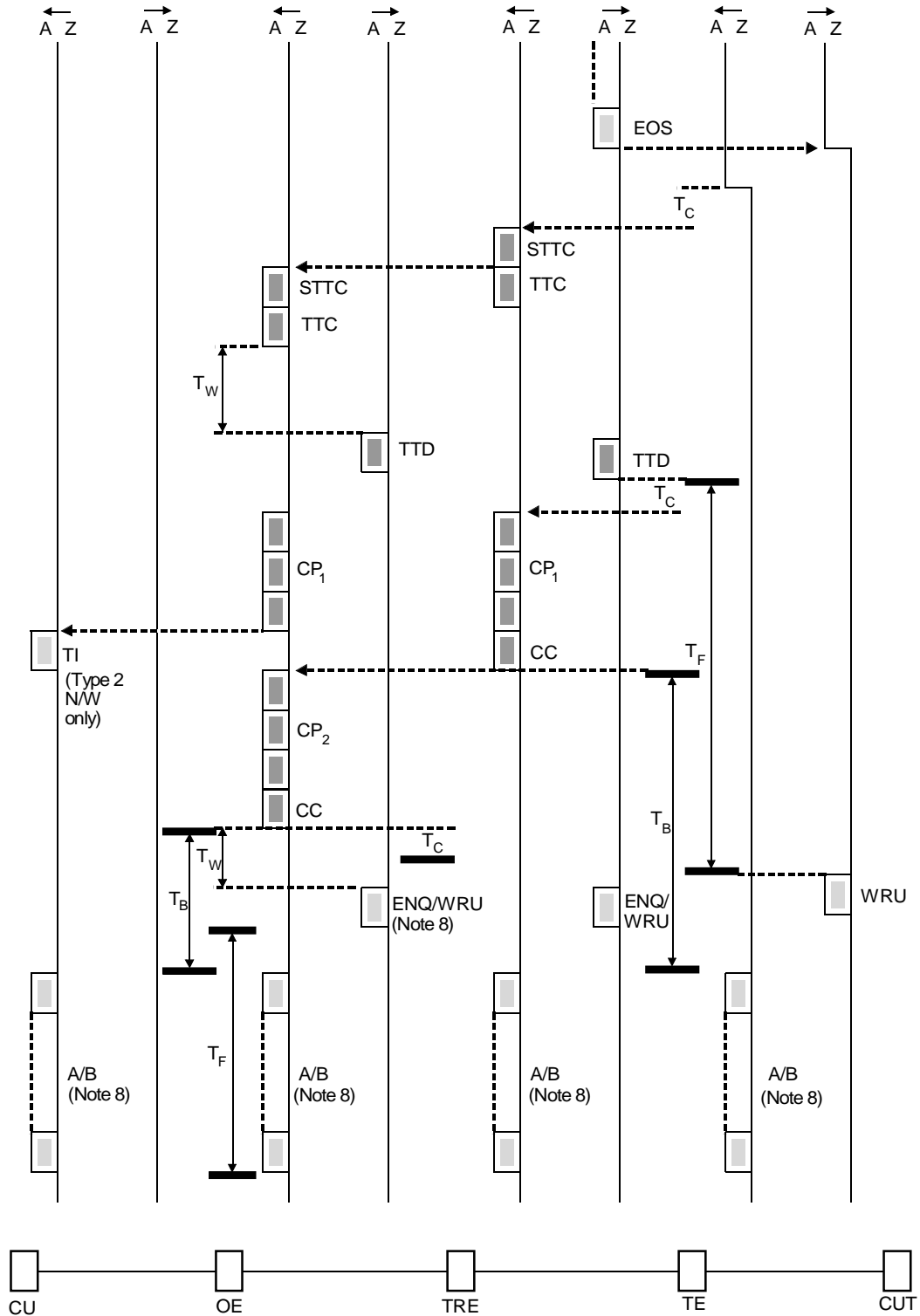

T0900910-93/d06

FIGURE 6/U.101

**Call progress signal without clearing (e.g. redirected call and speed/code conversion)  
generated at terminating and transit exchanges  
Option A – Transit Exchange appends its CPS after  
that of terminating exchange**

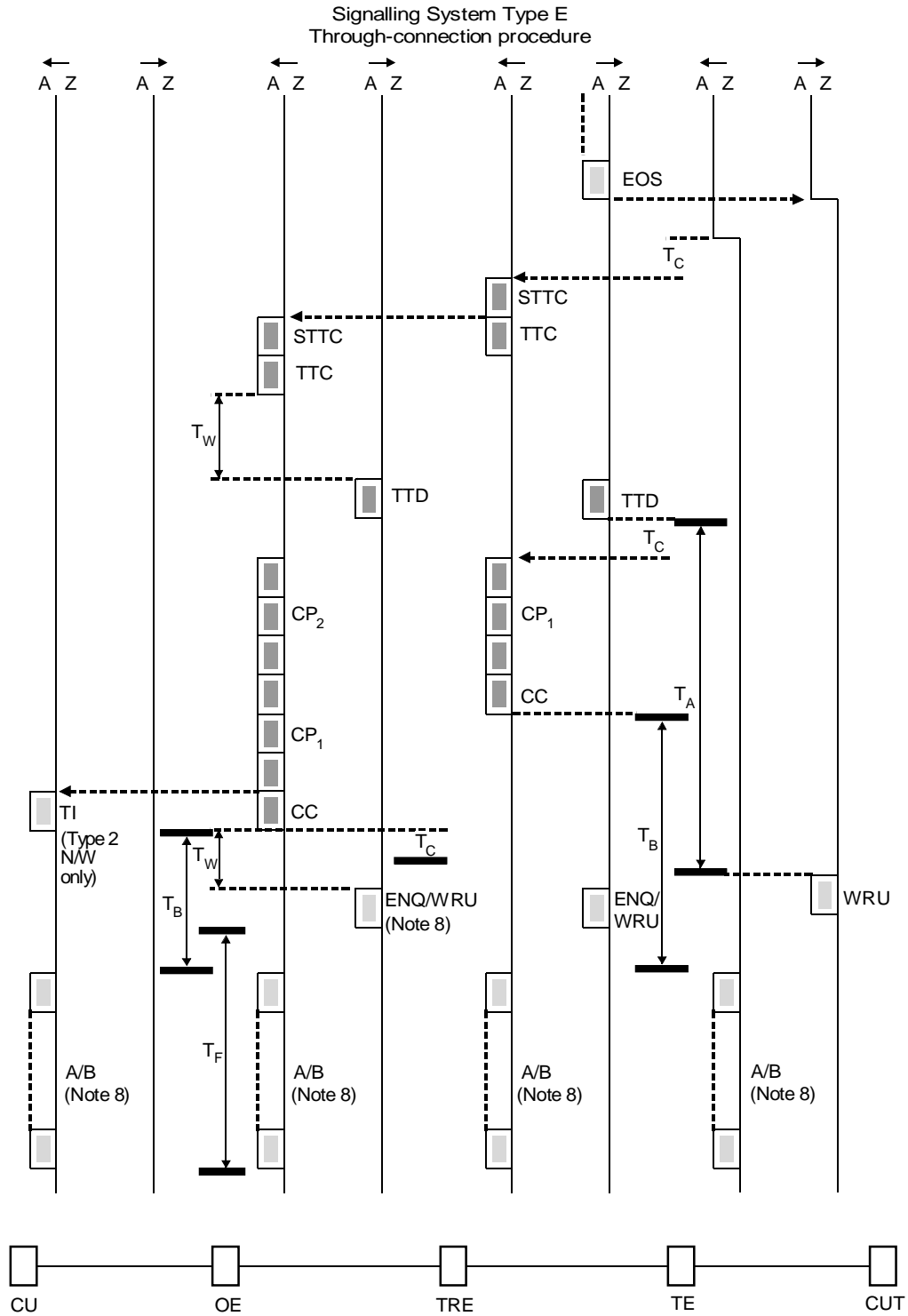

T0900920-93/d07

FIGURE 7/U.101  
**Call progress signal without clearing (e.g. redirected call and speed/code conversion)  
 generated at terminating and transit exchanges  
 Option B – Transit Exchange inserts its CPS before  
 that of terminating exchange**

**NOTES to Figures 1 to 7:**

- 1 Timings are shown as character periods (C). Switching and propagation delays are not included.
- 2 Forward path signals may also appear on the backward path, indicating a head-on collision on both-way circuits.
- 3 Network selection signals [Class-of-traffic (COT), user class characters, etc.]. Destination codes may comprise two or three digits (see Recommendation F.69).
- 4 Selection signals shall always be sent as a single block by the originating network with an End-of-Selection (EOS) signal in all cases.
- 5 The Network Identification signal comprises a distinctive character followed by the Destination code of the network concerned. This signal needs not be sent on calls within a national network.
- 6 The minimum and consequently the maximum periods will be lengthened at the request of the incoming country.
- 7 Service signals consists of CSC No. 11 followed by two characters of Table 7b.
- 8 For Type 2 Networks, 50 baud ITA2 signals are used at this stage.

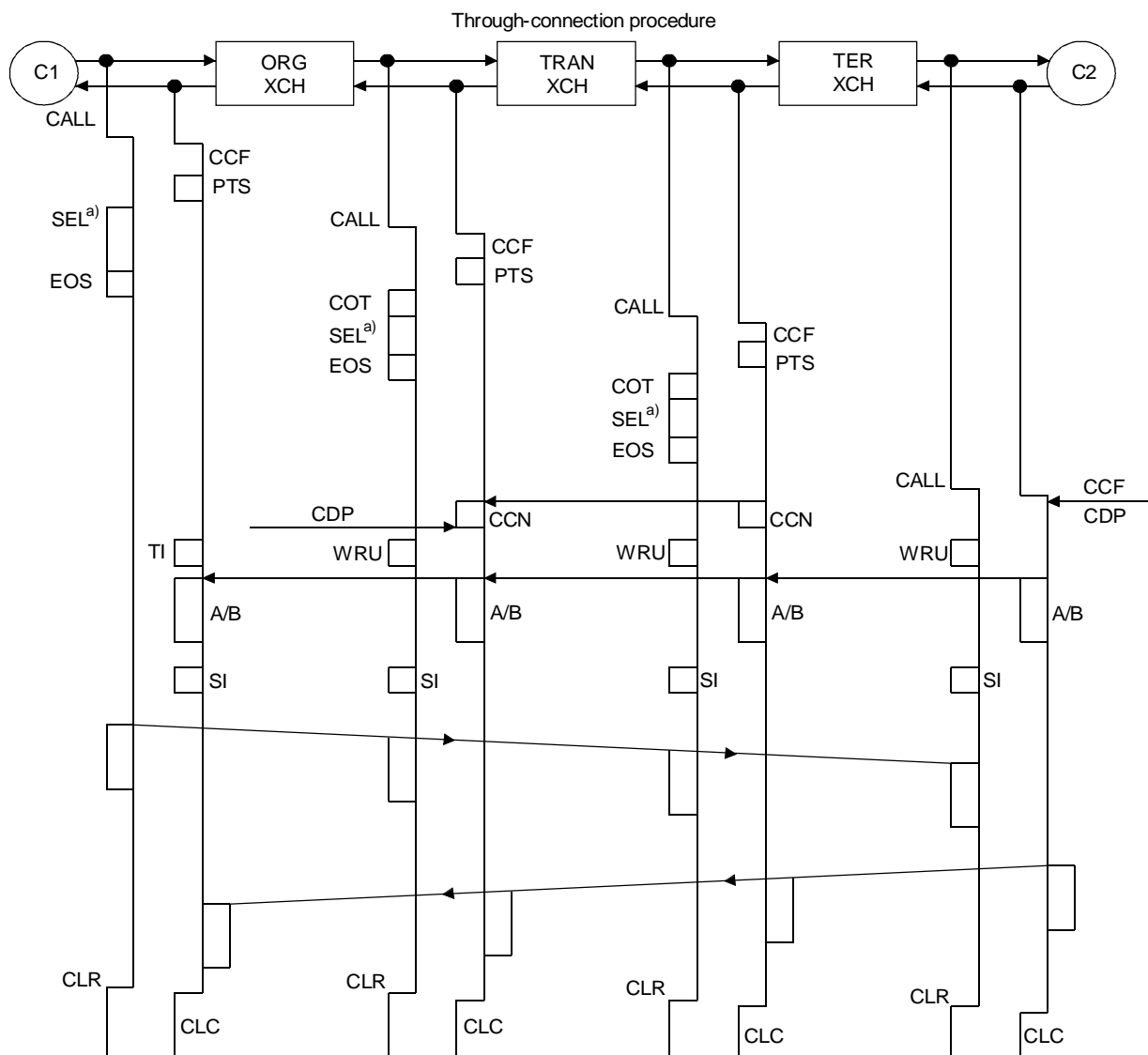

T0900780-91/d08

- CALL Call signal
- CCF Confirmation signal
- PTS Proceed to select signal
- COT Class-of-traffic signal
- EOS End of selection signal
- CCN Call connect. This is also used to flag the possible requirements for speed and/or code conversion, and/or trunk reselection
- CDP Characteristic decision point } Required for Type 2
- TI Telex indicateur signal } Networks only
- WRU Who are you signal?
- A/B Answerback
- TEXT Text
- CLR Clearing signal
- CLC Clearing confirmation signal
- SI Speed indicator – Required for type 1 networks only

<sup>a)</sup> Prerouting and overlap may be permitted.

NOTE – Wherever timings are appropriate they are in accordance with Recommendation U.1. Timings for speeds greater than 300 bauds are for further study.

FIGURE 8/U.101  
Type F signalling through connection procedure

## 2 Type F signalling

### 2.1 General switching and signalling principles

**2.1.1** Type F signalling is an adaptation of Recommendation U.1 Type A signalling for use on higher speed circuits. International Alphabet No. 5 (IA5) encoded characters are used to convey signalling information.

**2.1.2** Type F signalling is independent of the method of any speed and code conversion.

**2.1.3** Type F signalling may be used over synchronous or asynchronous channels, the former being code independent and able to support different speeds (baud rates) of synchronous characters.

**2.1.4** Decentralized signalling shall apply with the same channel being used for control signalling and information transfer.

**2.1.5** Both terminal and transit operation shall be supported. Due to the inclusion of transit operation, link-by-link signalling control of calls shall be adopted.

**2.1.6** Onward selection from transit and incoming terminal centres shall be arranged to overlap the reception of selection signals in order to minimize call set-up times. Selection signals shall be transmitted by the originating centre at automatic speed in a single block that includes an end of selection signal.

**2.1.7** The schedule of telex destination codes detailed in Recommendation F.69 shall apply. The same numerical codes shall be used for network identification purposes.

**2.1.8** Alternative routing shall be permitted but shall be restricted in order to prevent repeated alternative routing causing traffic to circulate. Alternative routing shall therefore be allowed only once in the originating network, once during international routing between the originating and terminal networks, and once in the terminal network.

**2.1.9** Both-way operation shall be assumed. In order to minimize head-on collisions inverse order testing of circuits shall be used. Also allowed is a close approximation to inverse order testing whereby the route is tested in small groups in fixed order always starting the search from the same position.

**2.1.10** Normally the originating network shall be responsible for recording accounting information. The recording of accounting information by other than the originating network is for further study.

**2.1.11** The Grade of Service for the provision of circuits shall not be worse than one lost call in 500.

**2.1.12** Operation of switching equipment shall be such that congestion shall not be signalled on more than 0.2% of calls in the busy hour, and only when congestion has been positively identified.

### 2.2 Specific signalling characteristics

#### 2.2.1 General

Class-of-traffic (COT) signals are used to signal forward the call originator's characteristics and to indicate, for transit calls, whether the call has originated on (or transited) a Type 1 or a Type 2 network and whether the call has been previously overflowed, should this be required.

#### 2.2.2 Signalling

- *Call (call)* – As defined in 3/U.1.
- *Call Confirmation (CCF)* – As defined in 4/U.1.
- *Proceed to Select (PTS)* – IA5 character 5/6 (V)
- *Class-of-traffic (COT)* – As listed in Table 10.
- *Selection Information (SEL)* – IA5 numeric characters which contain the called customer number preceded, where necessary, by the Telex Destination Code.

- *End of Selection (EOS)* – IA5 character 2/11 (+).
- *Call Connect (CCN)* – Single, discrete IA5 characters each defining how a call may proceed as described in Table 11.
- *Service Signals* – The content shall be in IA5 capital characters and in accordance with Recommendation F.60. They will be prefixed and suffixed with a carriage return and line feed sequence.
- *Reception of Service Signal CS (Change Speed)* – This shall initiate reselection of the call of an appropriate trunk group, as detailed in Recommendation U.103. This service signal shall not be extended back to the originating terminal.
- *Characteristic Decision Point (CDP)* – This is the point at which terminals on Type 2 network shall be instructed to change code and speed, by transmission of a Telex Indicator signal comprising IA5 character 5/1 (Q).
- *Who are you signal (WRU)* – A request for the answerback of a terminal to be sent. Both the WRU signal and the solicited answerback may be in either ITA2 or IA5 characters on Type 2 networks. On Type 1 networks only IA5 characters are used. The WRU signal comprises combinations 30 and 4 in ITA2 and character 0/5 in IA5.
- *Speed indicator sequence* – A sequence generated by Type 1 networks on calls between two Intex (or other higher speed) terminals, and which identifies the character rate at which the call may proceed. The format and meaning of these sequences is detailed in Table 9.
- *Clearing Signal (CLR)* – As defined in 9.1/U.1.
- *Clear Confirmation Signal (CLC)* – As defined in 9.2/U.1.
- *Guard Delay* – As defined in 9.3/U.1.
- *Retest Signal* – As defined in 10.5/U.1.
- *Bothway trunk head-on* – The detection and handling of head-on collisions is as described in 12.2/U.1.

TABLE 10/U.101

**Allocation of IA5 codes for COT signals<sup>a)</sup>**

		Cust. Alt. Routing Allowed	Cust. Alt. Routing not Allowed	SVC Alt. Routing Allowed	SVC Alt. Routing not Allowed
Type 1	ITA2/50	4/0	6/0	7/0	3/0
Type 1	IA5/300	4/1	6/1	7/1	3/1
Type 2	ITA2/50	4/2	6/2	7/2	3/2
Type 2	IA5/300	4/3	6/3	7/3	3/3
Type 2	ITA2/50, IA5/300	4/4	6/4	7/4	3/4
Type 1	IA5/600	4/5	6/5	7/5	3/5
Type 1	IA5/1200	4/6	6/6	7/6	3/6
Type 1	IA5/2400	4/7	6/7	7/7	3/7
Type 2	IA5/600	4/8	6/8	7/8	3/8
Type 2	IA5/1200	4/9	6/9	7/9	3/9
Type 2	IA5/2400	4/10	6/10	7/10	3/10
a) Allocation of additional COTs is for further study.					

TABLE 11/U.101

**Allocation of IA5 codes for call connect signals**

IA5	5/8	Call may proceed in IA5/300 mode
IA5	5/1	Call may proceed in IA2/50 mode
IA5	5/2	Call may proceed in IA5/600 mode
IA5	5/3	Call may proceed in IA5/1200 mode
IA5	5/4	Call may proceed in IA5/2400 mode

**3 Interworking between Types E and F signalling**

Interworking between Types E and F higher speed trunk signalling is for further study.