



INTERNATIONAL TELECOMMUNICATION UNION

ITU-T

TELECOMMUNICATION
STANDARDIZATION SECTOR
OF ITU

R.115

(03/93)

TELEGRAPHY

TELEGRAPH TRANSMISSION

MAINTENANCE LOOPS FOR TDM-SYSTEMS

ITU-T Recommendation R.115

(Previously "CCITT Recommendation")

FOREWORD

The ITU Telecommunication Standardization Sector (ITU-T) is a permanent organ of the International Telecommunication Union. The ITU-T is responsible for studying technical, operating and tariff questions and issuing Recommendations on them with a view to standardizing telecommunications on a worldwide basis.

The World Telecommunication Standardization Conference (WTSC), which meets every four years, established the topics for study by the ITU-T Study Groups which, in their turn, produce Recommendations on these topics.

ITU-T Recommendation R.115 was revised by the ITU-T Study Group IX (1988-1993) and was approved by the WTSC (Helsinki, March 1-12, 1993).

NOTES

1 As a consequence of a reform process within the International Telecommunication Union (ITU), the CCITT ceased to exist as of 28 February 1993. In its place, the ITU Telecommunication Standardization Sector (ITU-T) was created as of 1 March 1993. Similarly, in this reform process, the CCIR and the IFRB have been replaced by the Radiocommunication Sector.

In order not to delay publication of this Recommendation, no change has been made in the text to references containing the acronyms "CCITT, CCIR or IFRB" or their associated entities such as Plenary Assembly, Secretariat, etc. Future editions of this Recommendation will contain the proper terminology related to the new ITU structure.

2 In this Recommendation, the expression "Administration" is used for conciseness to indicate both a telecommunication administration and a recognized operating agency.

© ITU 1994

All rights reserved. No part of this publication may be reproduced or utilized in any form or by any means, electronic or mechanical, including photocopying and microfilm, without permission in writing from the ITU.

CONTENTS

	<i>Page</i>
2 Location of the loops.....	1
3 Names, types and definitions of the loops.....	1
3.1 Loop a – Digital multiplexer aggregate loop.....	1
3.2 Loop b – Analogue aggregate modem loop.....	1
3.3 Loop c – Analogue line loop.....	2
3.4 Loop d – Digital aggregate modem loop.....	2
3.5 Loop f – Tributary analogue loop.....	2
3.6 Loop g – Tributary digital loop towards the Muldex.....	2
3.7 Loop h – Tributary digital loop towards the tributary interface unit.....	3
4 Use of the loops.....	3
5 Methods of control.....	3
6 Control signalling.....	3
6.1 Alternative A.....	3
6.2 Alternative B.....	4
6.3 Maintenance channel signalling.....	5
7 Routing of the maintenance control signals.....	6
8 Application.....	6
9 Use of the maintenance channel.....	6

Recommendation R.115

MAINTENANCE LOOPS FOR TDM-SYSTEMS

(Malaga-Torremolinos, 1984; amended at Melbourne, 1988 and at Helsinki, 1993)

The CCITT,

considering,

- (a) the increasing use of TDM transmission systems;
- (b) the volume of information circulating on data and telegraph transmission networks;
- (c) the savings to be made by reducing interruption time on such links;
- (d) the importance of being able to determine responsibilities between the several parties who, of necessity, are involved in maintenance questions for the networks;
- (e) the advantages of standardization regarding maintenance,

unanimously declares the following:

1 The locating of faults can be facilitated in many cases by looping and other maintenance procedures in the TDM equipments. These maintenance facilities allow local or remote measurements to be carried out optionally by the Administrations and/or users concerned.

2 Location of the loops

The maintenance loops are positioned in order to make it possible for the Administrations to locate faults to the following function blocks:

- aggregate modem;
- TDM central logic;
- tributary interface unit;
- aggregate line;
- subscriber line.

The loops necessary to fulfil the above listed demands are shown in Figure 1. Additional loops may be used for the location of faulty boards but these loops are relevant to each particular manufacturer's implementation and are not included here. The number of maintenance loops may be extended to include the subscriber terminal equipment. These loops are left for further study.

3 Names, types and definitions of the loops

See Figure 1.

3.1 Loop a – Digital multiplexer aggregate loop

This loop is a one-way or optionally an echo-back loop (see Figures 2 and 3) that shall connect the aggregate data output to the aggregate data input of the TDM central logic. This loop shall be accomplished as close as possible to the digital aggregate interface.

3.2 Loop b – Analogue aggregate modem loop

This loop is a one-way loop or optionally an echo-back loop (see Figures 2 and 3). With this loop, the line signal from the output of the aggregate modem is looped back to the input of the aggregate modem. The loop should include the maximum number of aggregate modem components used in normal working.

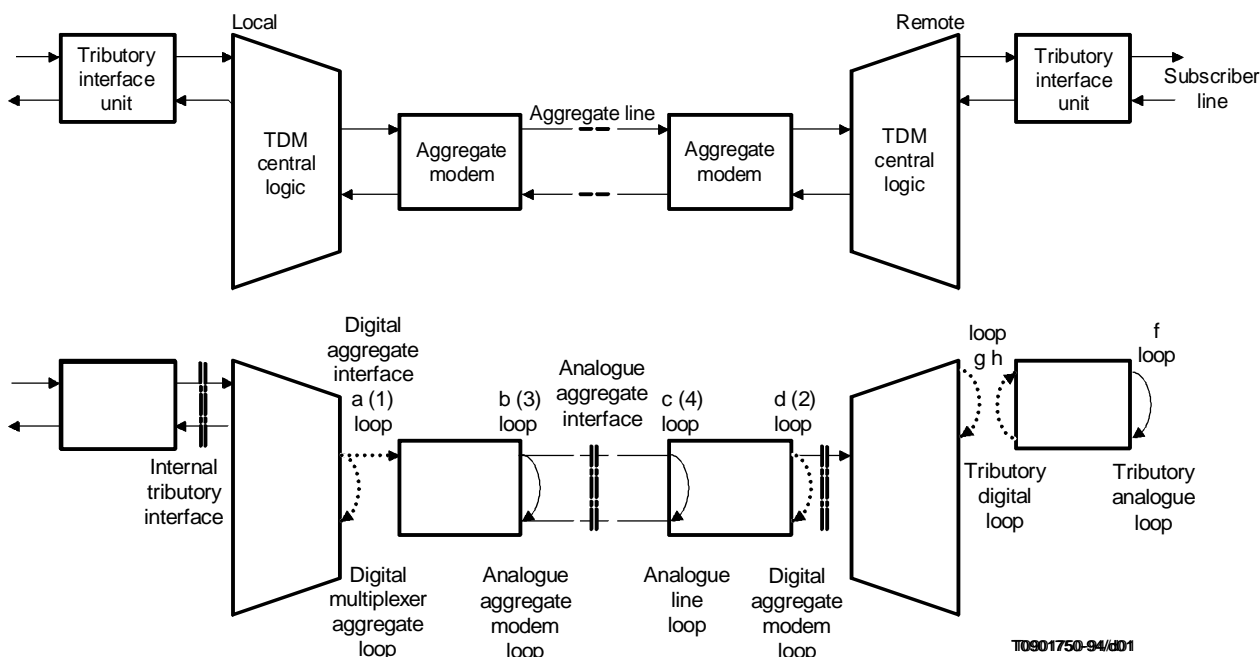

NOTES

- 1 A symmetrical set of loops exists as seen from the remote side.
- 2 Figures within parenthesis are the loop numbers according to Recommendation V.54.

FIGURE 1/R.115
Maintenance loops

3.3 Loop c – Analogue line loop

This loop is a one-way loop or optionally an echo-back loop (see Figures 2 and 3). With this loop, the incoming line signal at the receiver input of the aggregate modem is looped back to the outgoing direction of the line. It is noted that it may not be possible to correctly receive data that has been sent over the looped circuit.

3.4 Loop d – Digital aggregate modem loop

This loop is a one-way loop or optionally an echo-back loop (see Figures 2 and 3). In this loop the received aggregate digital data from the modem is looped back to the originating side. This loop shall be located as close as possible to the digital aggregate interface.

3.5 Loop f – Tributary analogue loop

This loop is a one-way loop (see Figure 2). With this loop, the tributary signal to be sent to the subscriber is looped back towards the multiplex system. This loop shall be accomplished at the subscriber line interface and shall include as many parts of the tributary interface unit as possible. As long as the loop is set the subscriber connection is interrupted.

3.6 Loop g – Tributary digital loop towards the Muldex

This loop is a one-way loop (see Figure 2) with the output polarity towards the tributary interface unit strapable to A or Z polarity. Through this loop the channel data as received from the aggregate is looped back to the aggregate towards the distant TDM equipment. This loop shall be accomplished as close as possible to the internal tributary interface which can be located on the tributary interface unit or in the TDM central logic.

3.7 Loop h – Tributary digital loop towards the tributary interface unit

This loop is a one-way loop with the output polarity towards the muldex-part of the given channel strapable to A or Z polarity. Through this loop the channel data at the tributary input is looped back to the channel output through the tributary interface unit. This loop shall be accomplished as close as possible to the TDM central logic.

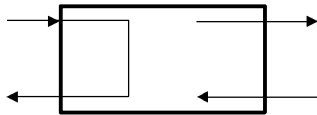

FIGURE 2/R.115
One-way loop

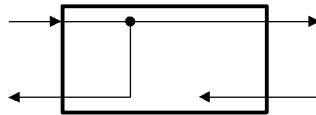

FIGURE 3/R.115
Echo-back loop

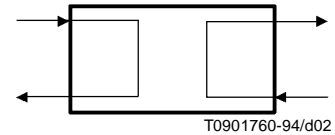

FIGURE 4/R.115
Both-way loop

4 Use of the loops

Loops c and d may be used under remote control on international links after bilateral agreements only.

5 Methods of control

5.1 Two types of control might be possible:

a) *Local control of a loop*

A loop is locally controlled when the loop request originates at the location of the equipment to be looped.

b) *Remote control of a loop*

A loop is remotely controlled when the loop request originates at a location other than that of the equipment to be looped.

5.2 When the aggregate modem is using a standard interface to the TDM-equipment, the implementation of the echo-back function and the controls through the digital aggregate interface of loops b, c and d are left for further study.

5.3 The control of loops a, b, c and d should be supervised by a time-out function. The time-out function shall automatically open the loop after a specified time period, measured from the closing of the loop. The length of the time period should be chosen from time intervals 5, 20 or 40 seconds by bilateral agreement between Administrations.

The operation and test procedure for loop f to h is a national matter.

6 Control signalling

6.1 Alternative A

When the maintenance facilities are controlled by the software within an exchange, a maintenance centre or a TDM terminal, a control signalling code (CSC) is used where the control signalling characters on the selected maintenance channel shall be in accordance with Table 1 (see also Table 8/U.12).

TABLE 1/R.115

CSC character number	Parity	Data					Decimal equivalent of data
	b ₄	b ₃	b ₂	b ₁	b ₀		
1	0	0	0	0	0	0	0
2	1	0	0	0	0	1	1
3	1	0	0	1	0	0	2
4	0	0	0	1	1	1	3
5	1	0	1	0	0	0	4
6	0	0	1	0	1	1	5
7	0	0	1	1	0	0	6
8	1	0	1	1	1	1	7
9	1	1	0	0	0	0	8
10	0	1	0	0	1	1	9

A complete control signalling code character consists of one start element (Start), followed by four information elements (b₀, b₁, b₂, b₃) one parity element (b₄), and a stop element (Stop) of nominally one and a half unit element, see Figure 5.

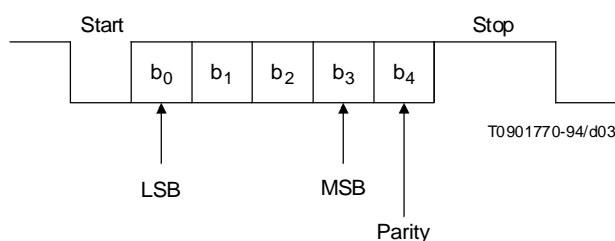

FIGURE 5/R.115
Complete control signalling code (CSC)

Bit b₀ is the least significant bit (LSB) and b₃ is the most significant bit (MSB). For the transmission of decimal numbers from 0 up to 99 the binary code should be used. The 8 binary bits should be split into two characters, No. 1 and No. 2, character No. 1 holding the least significant bits and character No. 2 the most significant bits.

6.2 Alternative B

When maintenance facilities do not use control signal according to Recommendation U.12, the signalling characters on the maintenance channel selected must conform to çInternational Alphabet No. 5 (IA5), with an even parity check (see Figure 6).

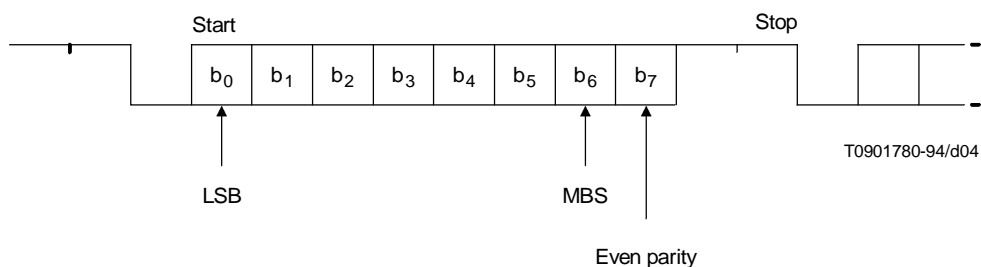

FIGURE 6/R.115
Control signalling format

6.3 Maintenance channel signalling

6.3.1 Alternative A

When using alternative A, all signalling information is described in Recommendation R.116.

6.3.2 Alternative B

In this case the following signalling shall be used.

The message consists of three parts:

- a) a heading formed by an autosynchronizable character repeated three times, all of whose units are equal to "1" (either "7F" or "FF" with even parity);
- b) a set of two characters (α and β) constituting the wanted information to be transmitted;
- c) a character depending solely on the system configuration (frame, type of channel: format, speed and alternative operation), which therefore makes it possible to check that both multiplexers have identical programming.

Maintenance information

- a) *Checking the state of the aggregate channel*

Character α : b0 to b7 = "0" (or "00")

Character β : b0: return to 0 of the system

b1: programming fault

b2: loss of frame alignment

b3: regrouped alarm

b4: first ("errored interval") fault threshold reached (see Note)

b5: second ("severely errored interval") threshold reached (see Note)

b6: request for aggregate channel state

b7: even parity

Therefore, in normal operation, the character β will have the value "00".

NOTE – The TDM equipment monitors the errors on the synchronization channel, for assessing the transmission performance.

- b) *Monitoring of link errors*

Character α : b0 = "1"

b1 to b6 = "0"

b7 even parity = "1"

Character β : b0 to b5 modulo 32 counter, aggregate of errors detected on the frame alignment word

b6: unused = "0"

b7: even parity

If there are no errors in the opposite direction, the meter will keep the same value.

- c) *Checking and maintenance of telegraph channels*

Character α : (No. of channel + 1) (2 to 47) expressed in binary

b0 to b5 from "02" to "2F"

b6 = "0"

b7 = even parity

- Character β :
- b0: analogue telelooping (loop f)
 - b1: digital telelooping (loop e)
 - b2: exceeding an adjustable limit (maximum 25%)
 - b3: local looping in progress
 - b4: reserved for subsequent use
 - b5: reserved for subsequent use
 - b6: request for telegraph channel state
 - b7: even parity

In the absence of any command, messages on the maintenance channel must be less than 15 seconds apart and they will be alternatively of type a) and b). This will enable each end of the link to obtain information on both directions of transmission.

In the event of a command (telelooping of a telegraph channel), messages for telegraph channels must never be more than three seconds apart.

7 Routing of the maintenance control signals

One 50 baud channel, or a channel of more than 50 bauds may be allocated (on an optional basis) for maintenance purposes, where possible on a separate system using a parallel route. Where this option is exercised the allocation of the maintenance channel is specified within the respective CCITT Recommendation or bilaterally between Administrations.

The selected maintenance channel should only be used for the transmission of alarms, supervision and remote control signals.

When there is no possibility to use a separate telegraph system on a parallel route, the *c* and *d* loop control can be performed by periodical carrier switching on and off during a period of time from 1.5 to 2 s by the following way:

- *switch on the loop c* – “There is no carrier” – 40 ms, “There is a carrier” – 40 ms, etc;
- *switch on the loop d* – “There is no carrier” – 80 ms, “There is a carrier” – 80 ms, etc;
- *switch off the loops c and d* – “There is no carrier” – 120 ms, “There is a carrier” – 120 ms, etc.

The diagrams of the signals are given in Figure 7.

8 Application

It may be possible to apply the described maintenance technique to multiplexors conforming to Recommendations R.101, R.111 and other standardized multiplexors. It may be possible to apply the described maintenance technique to multiplexors conforming to Recommendations R.101, R.111 and other standardized multiplexors.

9 Use of the maintenance channel

Use of the maintenance channel for purposes other than loop control is left for further study.

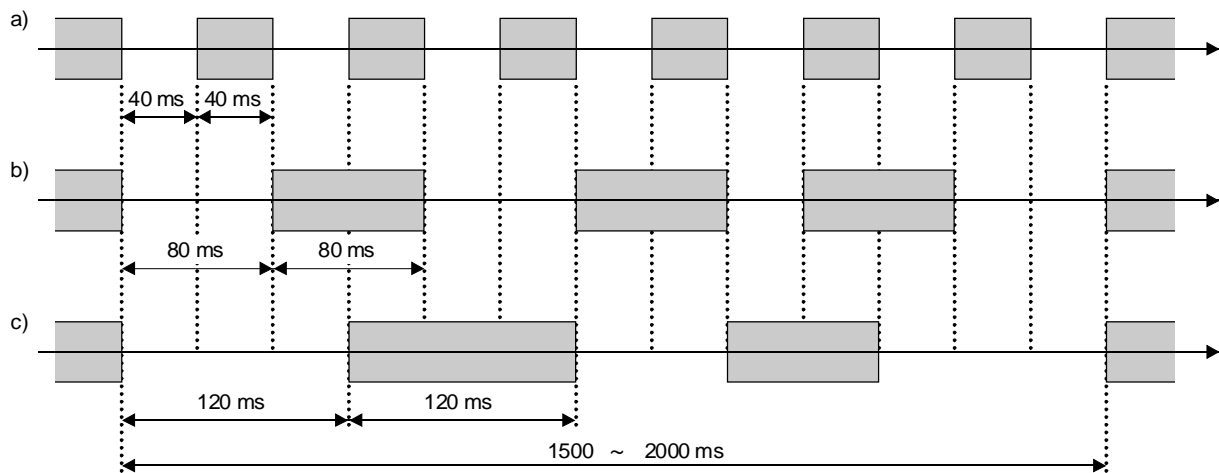

T0900870-92/d05

- a) Command to switch on the loop c.
- b) Command to switch on the loop d.
- c) Command to switch off the loops c and d.

Shaded area denotes the carrier signal transmission.

FIGURE 7/R.115