



INTERNATIONAL TELECOMMUNICATION UNION

**ITU-T**

TELECOMMUNICATION  
STANDARDIZATION SECTOR  
OF ITU

**Q.750**

(06/97)

SERIES Q: SWITCHING AND SIGNALLING

Specifications of Signalling System No. 7 – Signalling  
System No. 7 management

---

**Overview of Signalling System No. 7  
management**

ITU-T Recommendation Q.750

(Previously CCITT Recommendation)

---

ITU-T Q-SERIES RECOMMENDATIONS  
**SWITCHING AND SIGNALLING**

SIGNALLING IN THE INTERNATIONAL MANUAL SERVICE	Q.1–Q.3
INTERNATIONAL AUTOMATIC AND SEMI-AUTOMATIC WORKING	Q.4–Q.59
Signalling for circuit multiplication equipment	Q.50–Q.59
FUNCTIONS AND INFORMATION FLOWS FOR SERVICES IN THE ISDN	Q.60–Q.99
CLAUSES APPLICABLE TO ITU-T STANDARD SYSTEMS	Q.100–Q.119
SPECIFICATIONS OF SIGNALLING SYSTEMS No. 4 AND No. 5	Q.120–Q.249
SPECIFICATIONS OF SIGNALLING SYSTEM No. 6	Q.250–Q.309
SPECIFICATIONS OF SIGNALLING SYSTEM R1	Q.310–Q.399
SPECIFICATIONS OF SIGNALLING SYSTEM R2	Q.400–Q.499
DIGITAL EXCHANGES	Q.500–Q.599
INTERWORKING OF SIGNALLING SYSTEMS	Q.600–Q.699
SPECIFICATIONS OF SIGNALLING SYSTEM No. 7	Q.700–Q.849
General	Q.700
Message transfer part (MTP)	Q.701–Q.709
Signalling connection control part (SCCP)	Q.711–Q.719
Telephone user part (TUP)	Q.720–Q.729
ISDN supplementary services	Q.730–Q.739
Data user part	Q.740–Q.749
<b>Signalling System No. 7 management</b>	<b>Q.750–Q.759</b>
ISDN user part	Q.760–Q.769
Transaction capabilities application part	Q.770–Q.779
Test specification	Q.780–Q.799
Q3 interface	Q.800–Q.849
DIGITAL SUBSCRIBER SIGNALLING SYSTEM No. 1	Q.850–Q.999
PUBLIC LAND MOBILE NETWORK	Q.1000–Q.1099
INTERWORKING WITH SATELLITE MOBILE SYSTEMS	Q.1100–Q.1199
INTELLIGENT NETWORK	Q.1200–Q.1999
BROADBAND ISDN	Q.2000–Q.2999

*For further details, please refer to ITU-T List of Recommendations.*

## **ITU-T RECOMMENDATION Q.750**

### **OVERVIEW OF SIGNALLING SYSTEM No. 7 MANAGEMENT**

#### **Summary**

This Recommendation provides an overview of the functions, procedures and entities for managing the Signalling System No. 7 (SS No. 7) network.

The requirements upon SS No. 7 management are summarized, namely:

- a) to provide a Telecommunication Management Network (TMN) interface to the network operator;
- b) to interwork with other TMN parts (e.g. Synchronous Digital Hierarchy (SDH) to enable the provision of a unified approach to managing the whole telecommunications network; and
- c) to extend where necessary the internal management functions of SS No. 7, so as to amalgamate them with TMN. OMAP should also provide consistency between the SS No. 7 levels (layers) and across the SS No. 7 network.

The abstract model of SS No. 7 management is defined, and its relationship with the SS No. 7 levels is explained.

The management functions additional to those of OSI (e.g. functions for auditing routing, functions for testing implementations of levels of SS No. 7 from an in-service node, etc.) are explained.

Compatibility is considered, and an overview of the OMAP Recommendations is given.

#### **Source**

ITU-T Recommendation Q.750 was revised by ITU-T Study Group 11 (1997-2000) and was approved under the WTSC Resolution No. 1 procedure on the 5th of June 1997.

## FOREWORD

ITU (International Telecommunication Union) is the United Nations Specialized Agency in the field of telecommunications. The ITU Telecommunication Standardization Sector (ITU-T) is a permanent organ of the ITU. The ITU-T is responsible for studying technical, operating and tariff questions and issuing Recommendations on them with a view to standardizing telecommunications on a worldwide basis.

The World Telecommunication Standardization Conference (WTSC), which meets every four years, establishes the topics for study by the ITU-T Study Groups which, in their turn, produce Recommendations on these topics.

The approval of Recommendations by the Members of the ITU-T is covered by the procedure laid down in WTSC Resolution No. 1.

In some areas of information technology which fall within ITU-T's purview, the necessary standards are prepared on a collaborative basis with ISO and IEC.

## NOTE

In this Recommendation, the expression "Administration" is used for conciseness to indicate both a telecommunication administration and a recognized operating agency.

## INTELLECTUAL PROPERTY RIGHTS

The ITU draws attention to the possibility that the practice or implementation of this Recommendation may involve the use of a claimed Intellectual Property Right. The ITU takes no position concerning the evidence, validity or applicability of claimed Intellectual Property Rights, whether asserted by ITU members or others outside of the Recommendation development process.

As of the date of approval of this Recommendation, the ITU had/had not received notice of intellectual property, protected by patents, which may be required to implement this Recommendation. However, implementors are cautioned that this may not represent the latest information and are therefore strongly urged to consult the TSB patent database.

© ITU 1997

All rights reserved. No part of this publication may be reproduced or utilized in any form or by any means, electronic or mechanical, including photocopying and microfilm, without permission in writing from the ITU.

## CONTENTS

	<b>Page</b>
1 Introduction .....	1
2 Requirements for SS No. 7 management .....	2
2.1 OMAP layers of management functions .....	2
2.2 OMAP management categories.....	3
2.2.1 Fault management for OMAP.....	3
2.2.2 Configuration management.....	4
2.2.3 Performance management.....	5
3 Reference model for SS No. 7 management .....	6
3.1 OMAP functional reference model .....	6
3.1.1 Network management .....	7
3.1.2 Network element management.....	7
3.1.3 Network element functions .....	7
3.1.4 Relationship between network management and network element management .....	7
3.2 Physical realization for SS No. 7 management .....	8
3.3 OMAP and the OSI management model.....	10
3.3.1 OSI states, resource states, mapping and constraints.....	10
3.3.2 Managed object model .....	10
3.4 SS No. 7 managed objects and SS No. 7 structure.....	13
4 Communication profiles for management interfaces .....	16
5 Methodology.....	17
6 Backwards compatibility.....	18
6.1 Blue Book Recommendation Q.791 and the present OMAP.....	18
6.2 SS No. 7 networks without TMN.....	18
6.3 Existing SS No. 7 networks and their evolution to using TMN.....	18
6.3.1 Q-Adaptation function .....	18
6.3.2 Limitations upon the output to the TMN-OS.....	18
6.4 Compatibility within OMAP communication protocols .....	19
Annex A – OMAP Recommendations which apply to the TMN and SS No. 7 interfaces .....	19
Annex B – Recommendation for narrow-band SS No. 7 managed objects.....	20
Annex C – Management of the SS No. 7 part of broadband networks .....	20



## Recommendation Q.750

### OVERVIEW OF SIGNALLING SYSTEM No. 7 MANAGEMENT

(revised in 1997)

#### 1 Introduction

This series of Recommendations on the Operations, Maintenance and Administration Part (OMAP) define the functions, procedures and entities for managing the Signalling System No. 7 network.

The management functions of SS No. 7 are divided into three main parts, *viz.*:

- a) Management functions located in the Telecommunications Management Network (TMN) (which means the Network Element Functions (NEFs) and the Operations System Functions (OSF) – see Recommendation M.3010 [1]). These functions include measurement collection and cover TMN-to-TMN interactions; such management functions are modelled as managed objects at the interface between network elements and operations systems, or between operations systems.
- b) Management functions within the SS No. 7 protocol itself (e.g. changeover, forced rerouting, sub-system management, etc.).
- c) Management functions defined to enable verification and validation of routing tables, CICs, etc. These functions may require communication within the signalling network, and for this a separate protocol is defined. Such management functions are modelled as managed objects at the interface between the network elements and an operations system.

Of the three sets of management functions defined above, OMAP provides a) and c). Set b) can be modelled as existing within the "Layer Management Entities" of SS No. 7, and the functions are defined in the Recommendations pertinent to those layers.

OMAP interacts with all the layers (i.e. with all the levels) of SS No. 7 in order to effect control of the network.

Recommendation Q.750 gives the OMAP overview; the Q.751-Series of Recommendations define the SS No. 7 managed objects; Recommendation Q.752 (the successor to *Blue Book* Recommendation Q.791) defines the SS No. 7 monitoring and measurements; Recommendation Q.753 defines the SS No. 7 management functions for managed objects that themselves require SS No. 7 communication in the network, and also the OMASE-User where the logic of these functions is modelled (these functions are MRVT, SRVT and CVT, formerly defined in *Blue Book* Recommendation Q.795); Recommendation Q.754 defines the ASE for those functions defined in Recommendation Q.753, i.e. OMASE; Recommendation Q.755 defines the SS No. 7 Testers.

Figure A.1 shows the relationship between TMN, SS No. 7 management and the OMAP Recommendations.

OMAP uses principles of management defined in TMN Recommendation M.3010 [1], and in OSI Management Recommendations of the X.700-Series [2].

## 2 Requirements for SS No. 7 management

There are three main requirements for the management of SS No. 7 and its network. These may be summarized as:

- a) To provide a TMN interface for the network Administration<sup>1</sup>.
  - This requires that the Administration-to-OMAP interface has to be presented using TMN-defined concepts. See the Q.751-Series of Recommendations.
- b) To interwork with other TMN parts to enable the provision of a unified approach to managing the whole telecommunications network. Examples of these other parts are the Synchronous Digital Hierarchy (SDH) or the ISDN, which could be administered by the same body responsible for the MTP network – or TMNs of other jurisdictions (e.g. where an SCCP network covers more than one MTP network, one jurisdiction might exist for each MTP network).
  - This means that the OMAP managed objects (see the Q.751-Series of Recommendations) must be compatible with, and have appropriate attributes defined for interacting with, other TMNs' managed objects.
- c) To extend, where necessary, the management of the SS No. 7 network as described in functional SS No. 7 Recommendations (e.g. Recommendations Q.703 and Q.704 [3] for the MTP, Q.714 [4] for the SCCP), and to amalgamate this with the TMN approach.
  - Hence OMAP should provide for the complete management of the SS No. 7 network, it should provide consistency in approach between the different layers of SS No. 7, and it should provide consistency across the SS No. 7 network and its network elements.
  - OMAP should therefore be used to co-ordinate across the SS No.7 network the parameters for User Part, MTP and SCCP congestion control. This should allow these parameters to take values appropriate for the traffic mix and signalling and traffic volumes at each signalling point (e.g. timers  $T_a$  and  $T_b$  and the number of restriction levels, etc., for SCCP congestion control might need to be adjusted for the particular signalling point, but this should be consistent for the role of the SP in the SCCP network).
  - SS No. 7 already has defined certain management functions in its functional Recommendations (e.g. MTP signalling network management as defined in Recommendation Q.704 [3], and SCCP management as defined in Recommendation Q.714 [4]). These functions provide some automatic fault, configuration and performance management activities. OMAP has taken these functions into account in the definition of the behaviour of SS No. 7 managed objects. OMAP also extends the functionality already defined in, for example, the MTP Recommendations into a complete management service for the whole SS No. 7 network.

### 2.1 OMAP layers of management functions

The "layers" of management functions define the partitioning of management processes on a hierarchical basis.

The definition of TMN is concerned with five layers in management, namely business management, service management, network management, network element management, and the elements in the network that are managed.

---

<sup>1</sup> Here the word "Administration" in the term "network Administration" refers to the body or bodies (either telecommunication administration or ROA) responsible for controlling the SS No. 7 network.



Of these, OMAP currently is not concerned with business management, and interacts with other TMN parts to provide service management. For example, this latter interaction occurs if ISDN services require to be added so that subscribers at one exchange can use these services to subscribers at another exchange. If the Telephony User Part only is installed at those exchanges, it needs to be replaced or extended by the ISDN User Part, with corresponding addressing enhancements to the MTP implementation at those exchanges. The OMAP implementation would be involved in these changes.

The top management level proper of OMAP is network management, which provides the functions and resources to allow Administrations (possibly via a set of administration managed objects) to control the SS No. 7 network. Management functions and resources are provided by OMAP to allow management within the SS No. 7 signalling points. See clause 3 for further information on the OMAP reference model.

The definitions of both network management and network element management functions and resources utilize the TMN and OSI managed object approach, and allow changes to be coordinated within OMAP. Certain managed objects (e.g. signalling linkset and linksetNePart) have relations defined between them to allow network actions to be correlated with actions in concerned signalling points.

Relations are also defined between managed objects to allow "management hierarchies" to be satisfied (e.g. to forbid removal of a signalling linkset without first removing all its constituent signalling links).

## **2.2 OMAP management categories**

The purpose of management is to provide a service, and this can be classified as initial provisioning, maintaining existing service, and expansion or contraction of the service.

Management activities can be divided into categories which satisfy one or more of the above classifications.

OSI defines the categories of fault management, configuration management, performance management, accounting management and security management. Of these, the first three categories are applicable to OMAP; the last two are for further study in OMAP.

### **2.2.1 Fault management for OMAP**

OMAP fault management encompasses fault detection, location, isolation and the correction of abnormal operation of the SS No. 7 network. Correction of faults can in some instances require fault diagnosis. Faults can cause the network to fail to meet operational objectives (e.g. visible faults might reduce the network's traffic capacity, latent faults would reduce the network's reliability).

Fault management includes:

- Handling of alarm conditions, e.g. the failure of a signalling linkset or the inaccessibility of a signalling point.

The MTP provides automatic mechanisms in MTP signalling network management that attempt restoration of normal operation. OMAP network management takes account of these automatic mechanisms, and coordinates attempts of the network operator to handle abnormal situations and isolate faults within the network. Other levels of SS No. 7 have analogous automatic mechanisms.

This function includes the required interactions with resources of other TMN parts (e.g. transmission failures causing signalling link failures need to be correlated).

- The activation of measurements or tests. These include certain Recommendation Q.752 defined measurements, and the MTP route verification test.  
Such actions allow correlation of reports in an attempt to resolve and isolate specific faults. Where several signalling points detect similar errors, correlation across the network is useful in determining whether or not a single fault causes these errors, and if so, the location of it.
- Network-wide collection of statistics could be used by staff in preventive maintenance.
- Statistics collected about network elements might be used for detection of marginal performance of those elements.

### 2.2.2 Configuration management

Configuration management controls the resources of, and collects and provides data for, the signalling network and its components. This facilitates the preparation for, and initialization of, signalling services, and allows such services to be started, continued, and stopped.

Two main activities can be distinguished:

- setting the static configuration in the SS No. 7 network (e.g. installing and initializing SS No. 7 components); and
- altering the configuration of the network while it is running, and providing information about its changing state.

The division of effort between the two above activities depends, to some extent, upon the method adopted of installing the network. A network might be nearly fully provisioned at the start, and hence dynamic changes could be limited to preserving existing service, or it could be grown from a small initial provision, and thus dynamic configuration changes would initially mainly consist of those for growth.

Note that certain activities might require higher security authorization than others (e.g. removing from service the last linkset in a routeset).

Such activities require coordination within the network, and might also require activation or deactivation of network components.

For example, establishing a new route requires changes to routing tables at several signalling points; these changes require orchestration within OMAP so that all signalling points recognize the route at the same time.

The following OMAP functionality is required:

- a) Composition of routing tables at the concerned signalling points, from a routing plan determined by the Administration: This routing plan is subject to constraints imposed by the relevant SS No. 7 functional Recommendations (e.g. some of the MTP routing constraints are defined in Recommendation Q.704) and by additional constraints determined by the routing policy, network structure and capacities of the network resources.
- b) Verification of routing tables: This is a check for network consistency, and is done either by the Administration against the routing plan, using "reads" of the routing tables in relevant signalling points, or it is done by performing a Route Verification Test as defined in Recommendation Q.753. At present, only MTP and SCCP routing tables can be verified in the latter way, these tests also check all designated physical routes from origin to destination. Note that TMN-based functions equivalent to MRVT and SRVT are for further study.
- c) Installation and initialization of signalling linksets, and links within their defined linksets.

- d) Verification of consistency of naming between the two ends of certain network resources: For example, the SLC of a signalling link must be the same at each connected signalling point (an automatic signalling link test is also used in the MTP just before allowing the link into service), and the CIC of a speech circuit must be the same at each end.
- e) Initialization of network-wide protocol timers (e.g. MTP restart timers at emergency or normal values) and other protocol functions requiring network consistency.
- f) Interaction with resources used by other TMN parts on a network basis (e.g. transmission equipment used in configuring a signalling link).

OMAP provides facilities for the Administration to alter the configuration of the network whilst the network is running. OMAP also provides information on the internal automatic SS No. 7 management activities.

Thus, for example, a signalling link might be activated by the Administration in an already active linkset, because of failures of other links in the linkset. Such activities must take account of the management hierarchies defined amongst the OMAP managed objects, and will typically be constrained by the permissible state changes of the managed objects. These changes themselves are defined with respect to the hierarchy.

Dynamic configuration information includes the current use of the network as visible by the Administration. Thus, for example, a request for a display of the MTP routing data for a particular signalling relation might also result in the route currently used in the routeset being identified.

The particular facilities provided are defined by the operations applicable to, and the behaviour of, the managed objects defined in the Q.751-Series of Recommendations.

### 2.2.3 Performance management

This enables the behaviour of network resources and the effectiveness of communication activities in the network to be evaluated.

Functions to gather statistics, maintain and read logs of the network and system state histories, and to determine network performance under normal and abnormal conditions are provided.

Certain system parameters may be altered in order to monitor and change the performance of the network.

Network performance can be optimized by monitoring and managing the network.

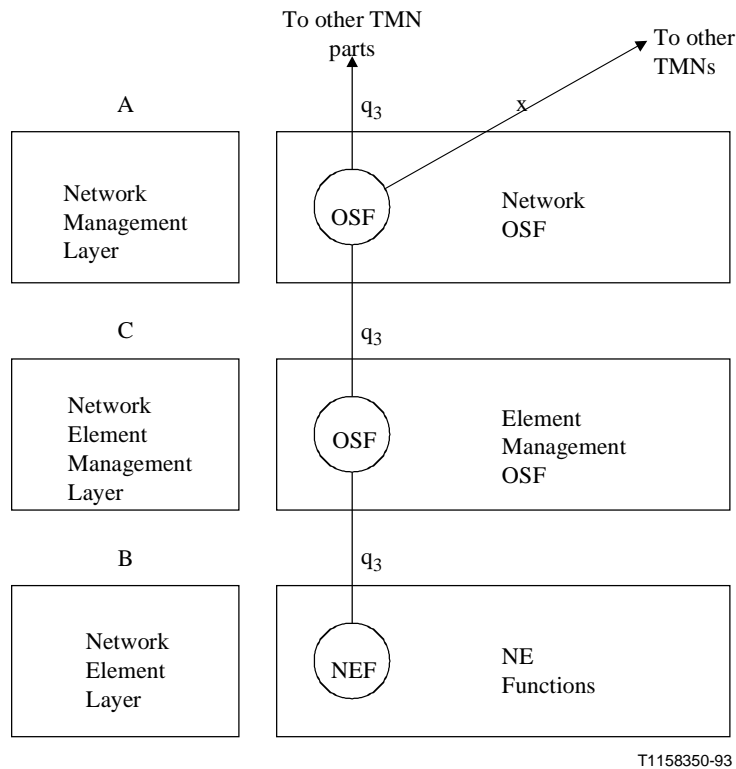
Performance management functions include:

- a) *collection of measurements to enable long and short term control, viz:*
  - i) alarm monitoring;
  - ii) activation of certain Recommendation Q.752 measurements;
  - iii) provision of network information from these measurements regarding resource usage, e.g. route utilization;
- b) *medium term control of resources, e.g.:*
  - i) modification of linkset capacity (e.g. increasing the number of active links);
  - ii) modification of route capacity (e.g. coordinated increase in constituent linkset sizes);
  - iii) timer adjustments;
- c) *real time control of message and traffic flows in the network, e.g.:*
  - i) real time adjustment of routing tables (e.g. changing time of day routing);
  - ii) activation of additional signalling links or linkset.

### 3 Reference model for SS No. 7 management

#### 3.1 OMAP functional reference model

TMN Recommendation M.3010 [1] defines five layers of management in a telecommunication network. Figure 1 (which is derived from Recommendation M.3010) shows three layers, and the reference points between them.



q q reference point  
x x reference point  
OSF Operations Systems Function

**Figure 1/Q.750 – TMN functional reference model as applied to SS No. 7 management**

OMAP provides network management and network element management for the SS No. 7 managed network. The simplified functional reference configuration based on the TMN model shown in Figure 1 above would show SS No. 7 network management as a single rectangle, with network elements located at signalling points.

The network management layer could be distributed in an implementation, any synchronization and orchestration required because of this distribution would be an implementation dependent matter, and not subject to standardization in the Q.750-Series Recommendations.

Figure 1 shows three TMN q reference points A, B and C. These reference points might become interfaces in an implementation of OMAP.

Point A is the reference point for SS No. 7 network management, point B is the reference point for SS No. 7 network element management.

Point C is also a reference point for SS No. 7 network element management, the view at point C can be the same as that at point B, with the understanding that several signalling points could be visible at C.

Network management allows the end-to-end control of managed objects, and ensures network coordination of the managed objects' constituent network element parts. Thus, for example, route management ensures the coordination and orchestration of changes in the routing tables situated in concerned signalling points, while linkset management coordinates actions at the linkset ends.

Network element management is performed on managed objects which are restricted to one network element (e.g. management of the managed object representing a signalling terminal).

### **3.1.1 Network management**

OMAP manages the SS No. 7 network. To do this, it coordinates, synchronizes and orchestrates activities in the network to achieve consistency between signalling points.

Certain items (e.g. signalling link, route, etc.) require information in more than one SP. Management (i.e. OMAP) at each SP requires a nodal view to manage the parameters of the item pertinent to one SP (i.e. the item is defined as a network element managed object), but in addition the coordination of the separate SP views to form the whole network view of the item is the responsibility of OMAP. Thus the information pertinent to one SP is given in a "nodal view" of an item, but included in this view must be any information to enable the construction of a network view of the item.

### **3.1.2 Network element management**

Certain items requiring management reside entirely within one signalling point (i.e. "node" of the network). For these, OMAP takes a "nodal view" of the item, and will present a nodal view of the associated managed object to the network operator. An example of such an item is a signalling terminal.

### **3.1.3 Network element functions**

The SS No. 7 network element functions are located within the signalling points, and comprise, for example, MTP, SCCP and ISDN User Part traffic carrying procedures.

### **3.1.4 Relationship between network management and network element management**

Where a network management-defined managed object has terminations in one or more signalling points, network element managed object(s) can be defined to represent these terminations. Relations are then defined between these objects for coordination of management actions.

Thus the "network view" is given by the network management object, the "SP view" is given by the network element managed object.

These managed objects form "clusters", where part of the cluster consists of network management-defined managed objects, the other part consists of network element managed objects. This clustering ensures coordination and orchestration of management actions: relations between the managed objects in the network management part and the network element management part define the interactions.

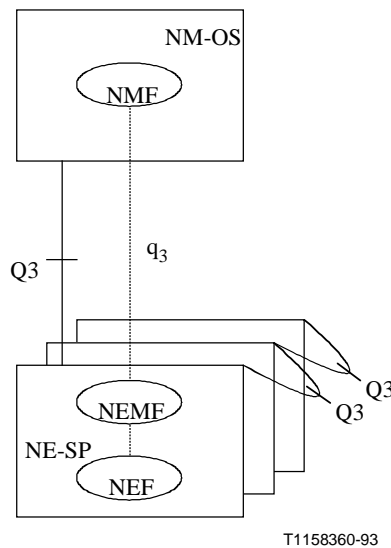
An example of such a cluster is the collection "signalling linkset" (which is the network management part) and "signalling linkset NE part". Relations defined between these two managed objects ensure that if, for example, a linkset is defined, then the appearance of one end of it in one signalling point and the other end in another signalling point are registered. Alternatively, if one end of the linkset becomes unavailable, MTP reports from each end are correlated and associated with the network management linkset managed object.

### 3.2 Physical realization for SS No. 7 management

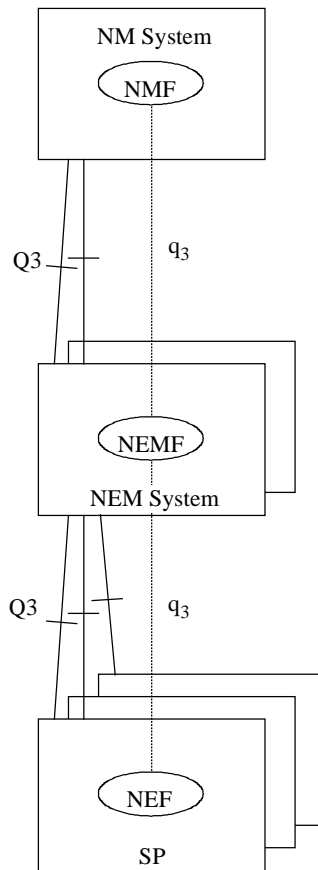
Three different example physical realizations are shown in Figure 2.

NOTE – In these diagrams, ellipses represent functional entities, rectangles represent physical entities.

- a) The first diagram (sheet 1) shows the Network Management Functional entity (NMF) resident in one network management centre, with the Network Element Management Functional entity (NEMF) resident in at least one signalling point, and the Network Element Functional entity (NEF) resident in the signalling points. The  $q_3$  reference point between NMF and NEMF is realized as a Q3 interface. The  $q_3$  reference point between NEMF and NEF is realized as a Q3 interface if the NEMF and NEF are in different signalling points.
- b) The second diagram (sheet 2) shows a single network management centre, several network element management centres, and the signalling points containing the NEFs.
- c) The last diagram (sheet 3) shows the NEMF combined with the NMF in a single network management centre.

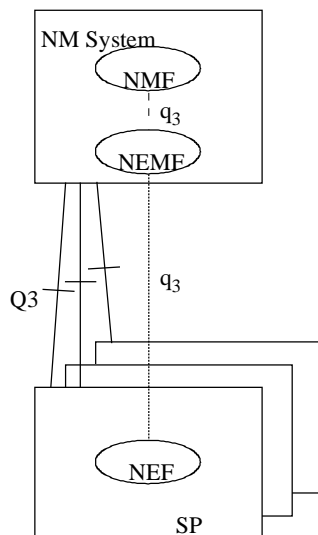


**Figure 2/Q.750 (sheet 1 of 3) – Example physical realization for SS No. 7 management**



T1158370-93

**Figure 2/Q.750 (sheet 2 of 3) – Example physical realization for SS No. 7 management**



T1158380-93

**Figure 2/Q.750 (sheet 3 of 3) – Example physical realization for SS No. 7 management**

### **3.3 OMAP and the OSI management model**

#### **3.3.1 OSI states, resource states, mapping and constraints**

Recommendation X.731 [5] defines the OSI state management function. Each OMAP managed object's "OSI state" (i.e. the state perceived for its management) should be defined as part of the object behaviour definition in the Q.751-Series of Recommendations. If the managed object has a "functional state" defined, then the mapping between functional state and OSI state is also part of the object definition. Informal descriptions of behaviour could use text; SDL might be used for a more formal description.

The management hierarchies within which SS No. 7 resources are active constrain the state changes of managed objects. For example, a manual request to take a signalling link out of service might be refused if this means that its "owning" linkset then goes out of service and thereby a destination becomes inaccessible.

OSI management also defines log control functions and alarm reporting. The former enables certain measurements to be collected, the latter allows notification of urgent events. Each managed object's definition provides, where appropriate, for interaction with these functions, and managed objects are defined for their control.

Discriminator functions are also defined in OSI to enable reports to be made or measurements to be collected only if a threshold is exceeded.

#### **3.3.2 Managed object model**

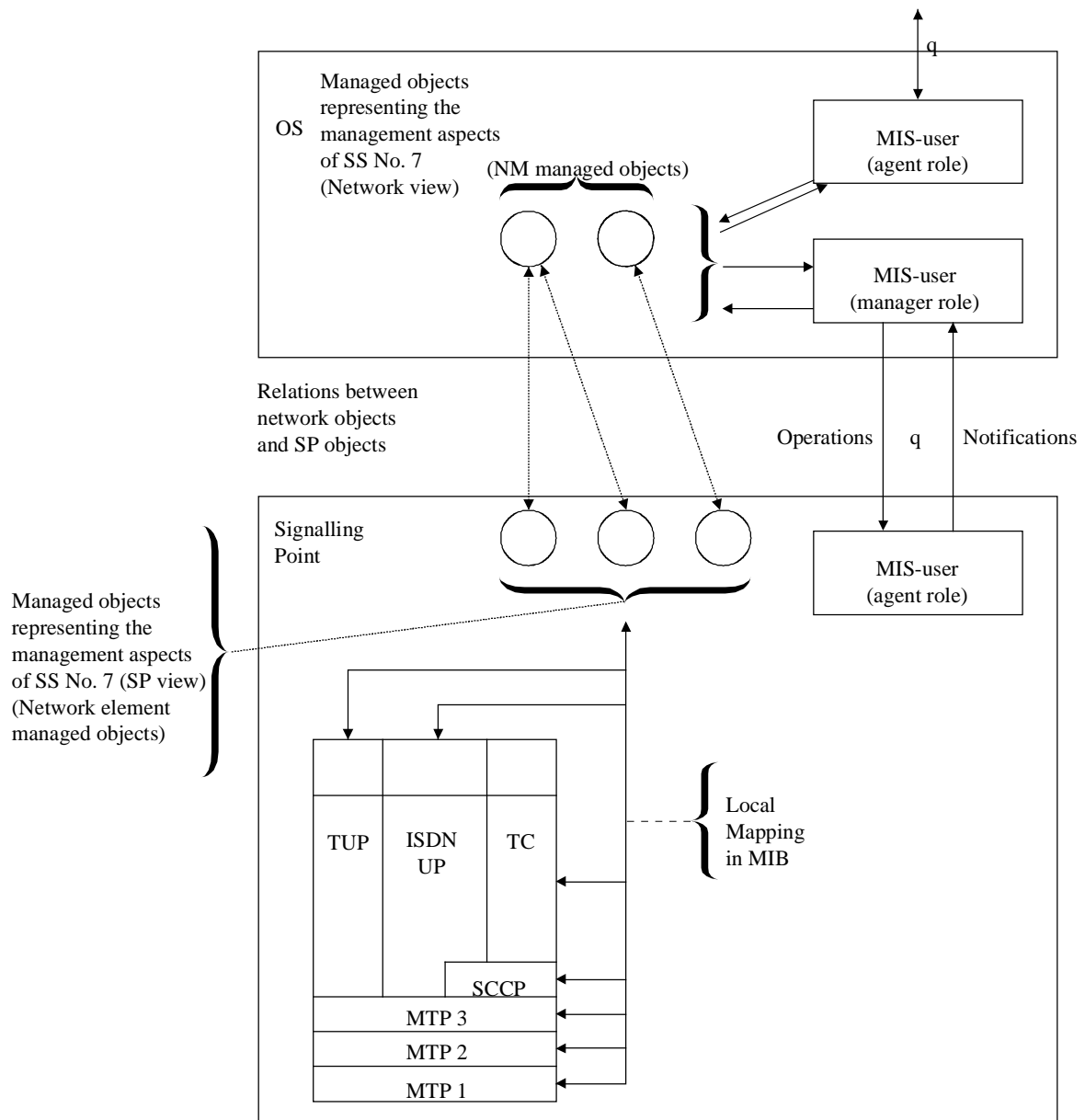
OSI systems management (see Recommendation X.701 [2] for example) defines a model of management, and this model is employed in OMAP. The model is used for most of the OMAP managed objects. Figure 3 shows this model.

Communication in the SS No. 7 network can occur between resources represented by this type of managed object. Any such communication is invisible to the Administration, it is defined in the resources' functional Recommendations (e.g. Q.703 and Q.704 for MTP resources), and not by OMAP.

If synchronization is required in the TMN for network management managed objects of this type, then OMAP relations are defined between these managed objects and the appropriate network element managed objects.

For other OMAP managed objects (e.g. MRVT), the model is modified. Figure 4 shows this modified model. Here, the object is spread over more than one signalling point, but in non-failure operation, the originating signalling point is the only one at which the object interacts with the Administration. The coordination, communication and synchronization of activities between signalling points occurs as an internal function of the object and is defined in OMAP. Explicit relations between network management managed objects and network element managed objects are not required to enable synchronization.

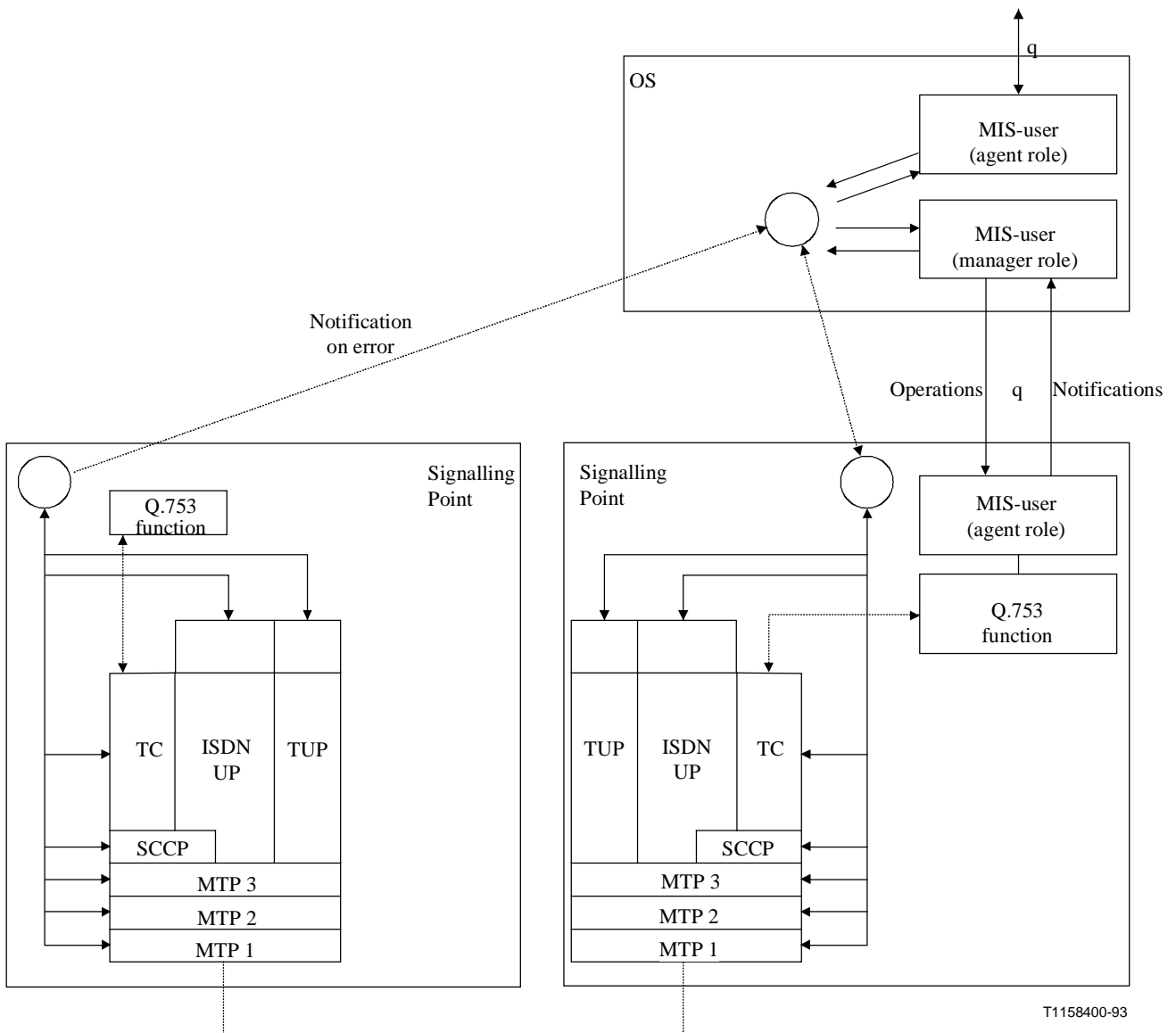




T1158390-93

MIS Management Information Service

**Figure 3/Q.750 – Classical OMAP managed objects model**



**Figure 4/Q.750 – Managed objects using internal communication**

### 3.3.2.1 Classical OMAP managed object model

Recommendation X.701 [2] defines management in terms of an MIS user in a manager role, governing the behaviour of an MIS user in an agent role.

This model is the preferred one for SS No. 7 management managed objects, except where the object is an abstraction of a test of the SS No. 7 network itself.

The way OMAP uses the model is represented in Figure 3.

A typical managed object in the network view is a signalling linkset; operations performed on an instance might result in operations being performed upon two instances of the managed object signalling linkset NE part, one instance being in one signalling point, the other being in another SP.

In some cases, e.g. for scheduled management activities, the MIS-user (manager role) operates autonomously in the OS handling the network management aspects.

The managed object class definitions are an abstraction from the properties of the items defined in the functional Recommendations. Thus, for example, those items defined in Recommendation Q.704 (e.g. signalling link, linkset, etc.) representing resources which interact with "management" are represented as managed objects either on the network element management reference point or on the network management reference point. The properties of the items shown interacting with management, by e.g. Recommendation Q.704, given in the initial entity-relationship diagrams in Recommendation Q.751.1, are abstracted to provide entity-relationship diagrams showing containment and naming relations.

### **3.3.2.2 OMAP managed objects using internal communication**

Here certain managed objects (e.g. MRVT) are defined to allow the network operator control, but communication is required within the SS No. 7 network between signalling points to correlate actions. From the Administration's perspective, the managed object is simple, and an instance can be started from one signalling point, but the SS No. 7 resource represented in the MIB spans more than one signalling point. Conceptually, for example, there could be a transient MRVT instance for every signalling relation in every signalling point in the network. Figure 4 shows this.

Note that the internal communication in the SS No. 7 network employed by these objects is part of their behaviour.

Examples of such managed objects are the MTP Routing Verification Test (MRVT) SCCP Routing Verification Test (SRVT) and Circuit Validation Test (CVT). See Recommendation Q.753 for their definition.

The MRVT, CVT and SRVT use the "short stack", with ASEs defined for use with TC (Recommendations Q.771 to Q.775 [6]), for communication over the SS No. 7 network. The protocol profile is defined in clause 4.

Other examples of such objects are the MTP Tester (MT) and the SCCP Tester (ST) (see Recommendation Q.755). The Tester managed objects use just the SS No. 7 levels that are being tested, with support from any underlying levels, for communication.

## **3.4 SS No. 7 managed objects and SS No. 7 structure**

OMAP is used in managing the SS No. 7 network. The definition of this function uses a management model (see e.g. Recommendation X.701 [2]) which contains a Management Information Base (MIB) through which OMAP exerts control over the items requiring management in each level of SS No. 7. Each level possesses a Layer Management Entity (LME) in which these items (conceptually) reside. OMAP at a signalling point can thus control items in the local LMEs via the local MIB.

Each level of SS No. 7 has managed objects defined to allow administrative control and monitoring. Certain managed objects span more than one level or more than one vertical functional division [e.g. a Signalling Point (SP)].

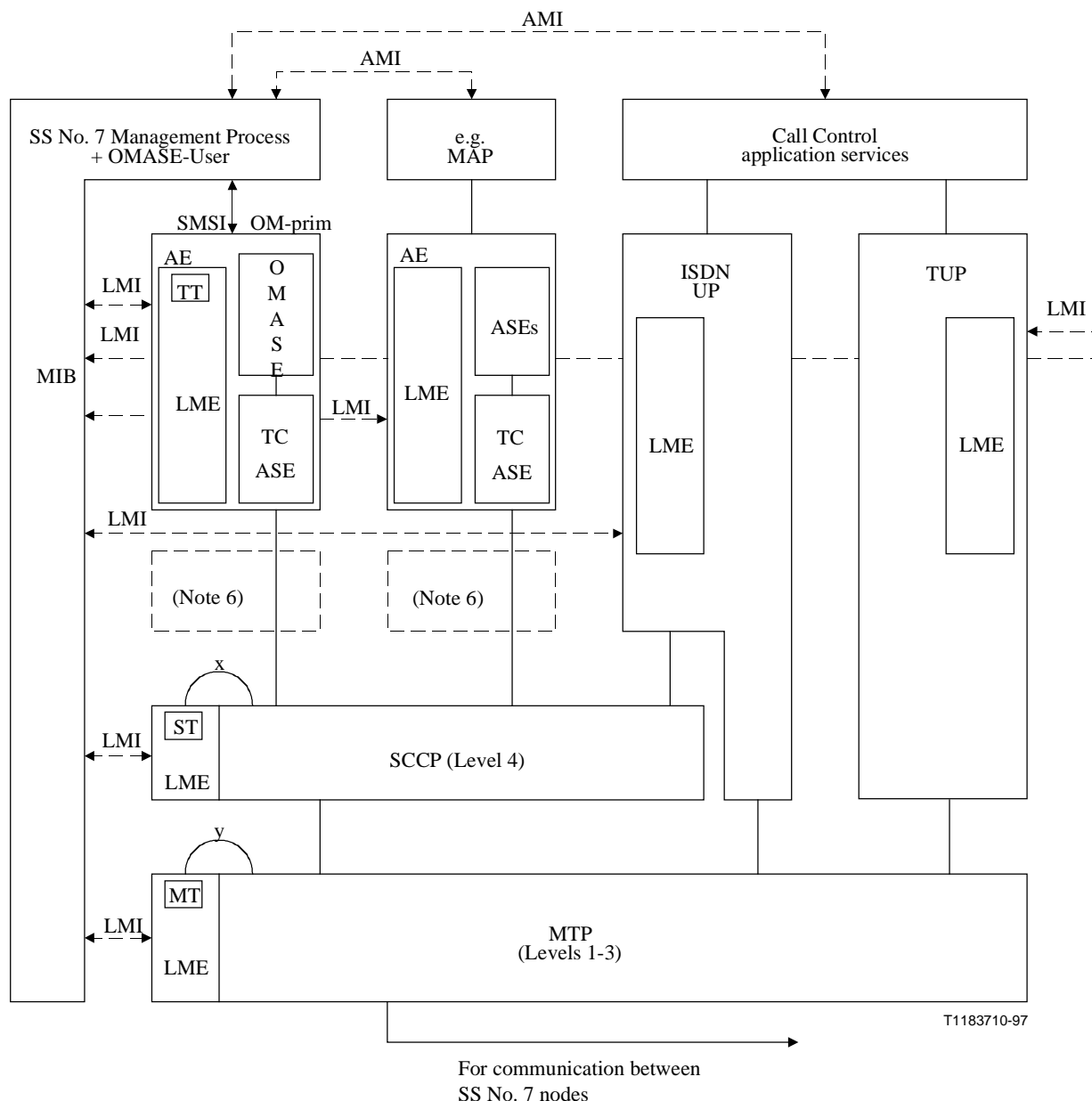
Some objects (e.g. signalling terminal) are particular to just one signalling point, and are therefore network element managed objects.

Other objects span more than one SP and consequently are defined as network management managed objects. An example of the latter is a signalling linkset.

Managed objects have relations defined between them to allow coordinated and orchestrated management. Coordination is required, for example, when defining a route: each signalling point and linkset in the route has to be identified and made ready, each link in each linkset might be affected. In addition, the commitment of the changes to the termination points of the managed objects needs to be synchronized.

In its management, OMAP takes an "OMAP view" of the items presented for management by the other layers of SS No. 7. OMAP defines the rules which obtain between items managed in the SS No. 7 network where these items span or affect more than one layer of SS No. 7 (e.g. a routeset defined in the MTP might affect circuits connected between the signalling end points, where these circuits are controlled by TUP or ISDN-UP, and OMAP must coordinate the UP and the MTP).

Figure 5 shows both the functional relationship between the different levels of SS No. 7 for management, and the internal configuration model of the signalling point. Figure 5 *bis* shows a candidate for the entity-relationship diagram used for naming TC and its applications (the object model is for further study).



NOTE 1 – Dotted lines (but not boxes) denote direct management interfaces. Only the SMSI (see Note 5 below) is realized with primitives.

NOTE 2 – The LMI (Level Management Interface) is not a subject for standardization.

NOTE 3 – The AMI (Application Management Interface) is not a subject for standardization.

NOTE 4 – The items managed by OMAP can be regarded as conceptually resident in the MIB.

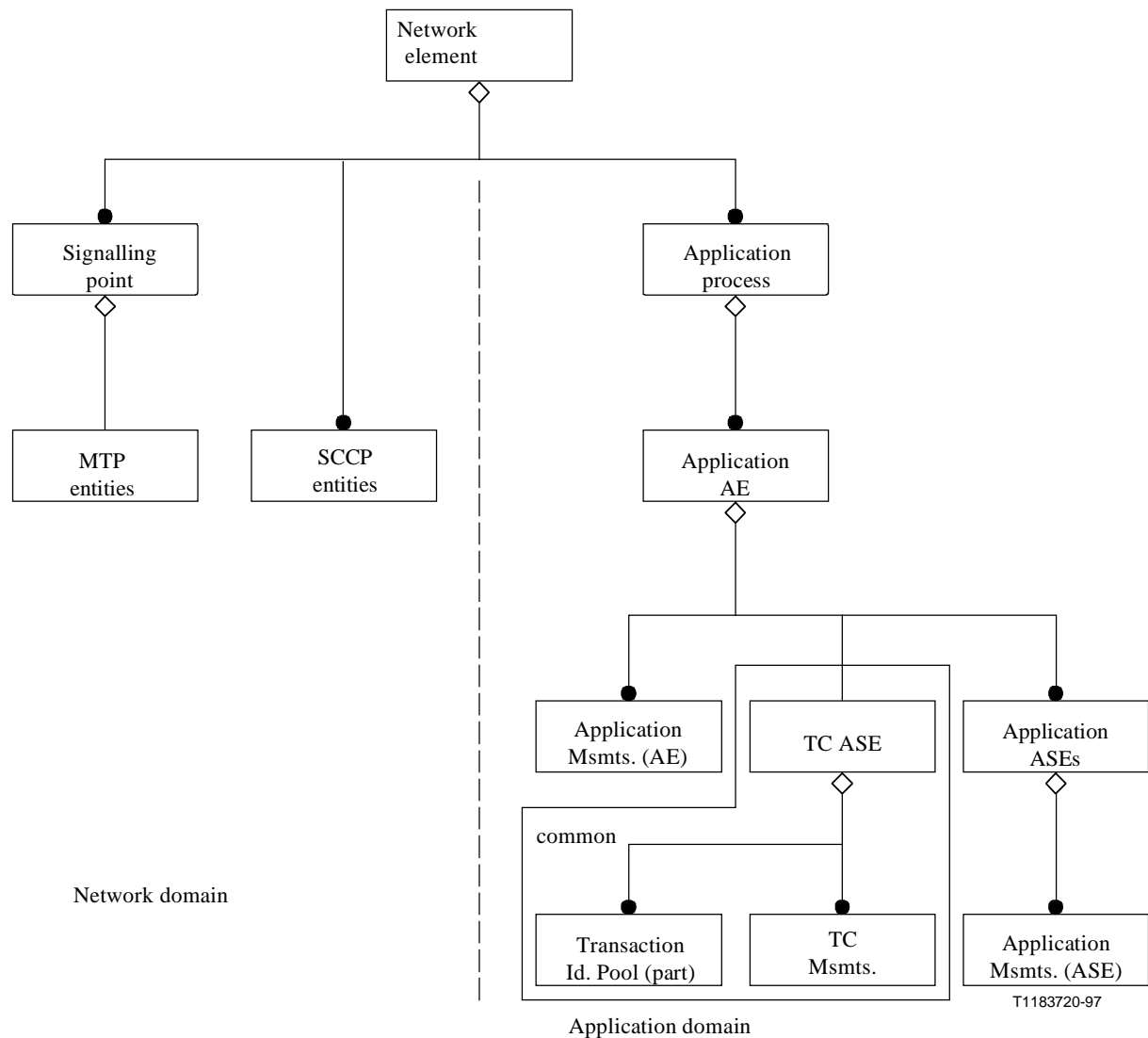
NOTE 5 – The SMSI is the systems management service interface, the OM primitives are defined for use over it for managed object functions defined in Recommendation Q.753.

NOTE 6 – OSI layers 4, 5 and 6 are null in SS No. 7. TC forms the bottom of OSI layer 7; SCCP the top of OSI layer 3 (but is in SS No. 7 level 4).

NOTE 7 – Interface x uses sub-system number to test the SCCP using the SCCP Tester (ST); interface y uses SIO to test the MTP using the MTP Tester (MT). The TC Test Responder (TT) has its own SSN, conceptually it resides in the OMAP LME.

NOTE 8 – The LME (Level Management Entity) is defined for management of and within each level of SS No. 7. This is conceptually where each managed item resides as far as the level is concerned.

**Figure 5/Q.750 – SS No. 7 management and internal configuration of an SP**



◇ containment relation  
 — multiplicity is 1: exactly one  
 —● multiplicity is 1: many (zero or more)

NOTE 1 – This figure shows a possible naming relation between managed object classes. The relationship between managed object instances at a signalling point is an implementation-dependent matter.  
 NOTE 2 – There might be just one Transaction Id. Pool for all subsystems depending upon implementation, and so it is shown as possibly a part per application (subsystem).

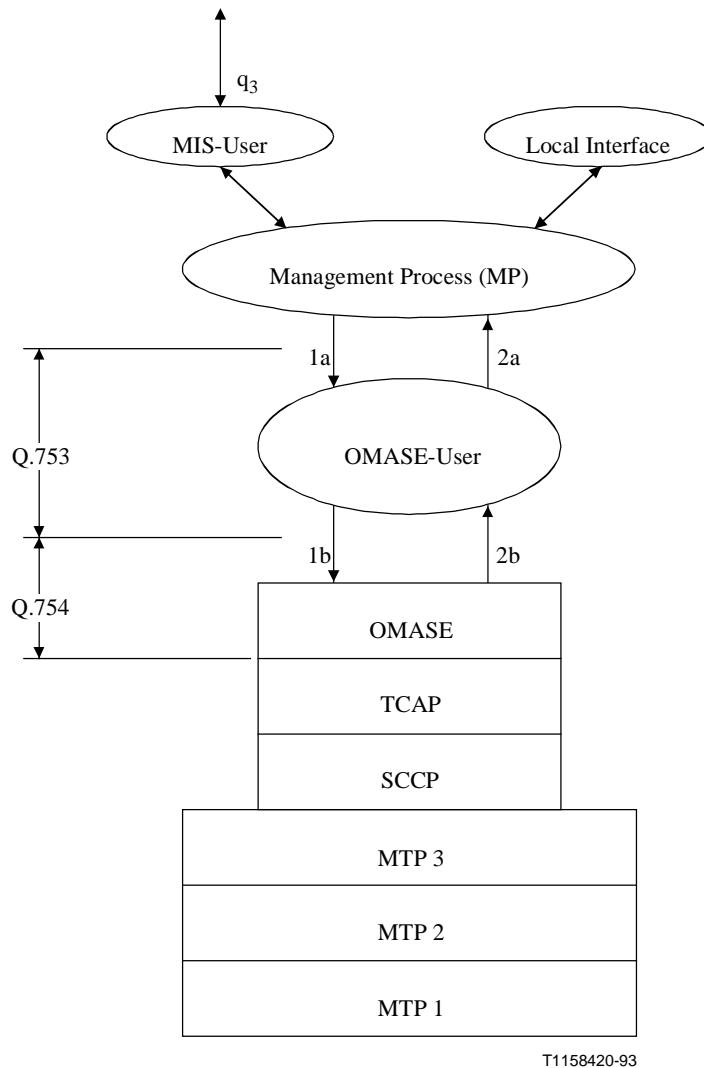
**Figure 5 bis/Q.750 – Entity-relationship diagram for naming TC and its applications: Signalling Point (SP) view**

**4 Communication profiles for management interfaces**

For those managed objects defined in the Q.751-Series of Recommendations, management communication is effected using the Q3 interface. Figure 3/Q.811 defines the lower layer parts of the protocol stack; Figure 2/Q.812, defines the upper layer parts [7].

Note that the stack using MTP and SCCP is for further study: the upper SCCP interface would need to supply an NSAP addressing mechanism for the stack to be used for the Q3 interface.

Communication using the SS No. 7 network for the functions defined in Recommendations Q.753 and Q.754 of certain managed objects (e.g. MRVT, SRVT, CVT), uses the protocol profile defined in Figure 6.



NOTE – See Recommendation Q.753 for the mapping of the primitives between interfaces "a" and "b".

**Figure 6/Q.750 – Short stack used for internal SS No. 7 management protocol**

## 5 Methodology

The three-stage description technique has been applied for the management functions defined in Recommendations Q.753 and Q.754.

Stage 1 is an informal text description of the properties and behaviour of such managed objects, and is documented in Recommendation Q.753. Stage 2 is a description of the information flow, and is informally described in Recommendation Q.753, more formally in Recommendation Q.754. Stage 3 is a formal description of information flow, and uses ASN.1 and ASE definitions. These are documented in Recommendation Q.754.

For the managed objects, the methodology adopted is that described in the Annex D/Q.751.1. The behaviour of a managed object is currently defined in text. This definition also includes constraints to be satisfied by the object for satisfactory operation in the network. A formal description of these properties will be provided when an appropriate technique is approved [e.g. the routing rules for the MTP imply constraints upon routesets, routes (capacity, connectivity, number of "hops", circularity avoidance, etc.), linksets and links within linksets].

## **6 Backwards compatibility**

### **6.1 Blue Book Recommendation Q.791 and the present OMAP**

*Blue Book* Recommendation Q.791 has been supplanted by Recommendation Q.752. The changes in the latter Recommendation are:

- *Additions* – These include measurements for connection-mode SCCP, MTP User part availability, ISDN-UP and TC.
- *General changes* – Some measurement intervals of 30 minutes will in future be five minutes, a change in some cases from "on occurrence" reporting to "1st and interval" counts.
- *Detailed changes* – e.g. measurement 2.15 is now a count of LSSU SIBs sent during a five-minute period, rather than a measurement of the busy duration in this period.

### **6.2 SS No. 7 networks without TMN**

TMN will possess the capability of filtering reports, so that human-readable output can be kept at a manageable level. Where a TMN-OS is interposed between an implementation of SS No. 7 and the human-machine interface, the SS No. 7 network could output high volumes of measurements, and Recommendation Q.752 caters for this.

Current implementations of SS No. 7 limit the output to human-machine interfaces in a variety of ways; these mechanisms are not specified in Recommendation Q.791. The intent is to limit the volume according to the output medium.

Until these networks implement TMN, they may continue to use Recommendation Q.791 (or those parts of Recommendation Q.752 derived from Recommendation Q.791), with perhaps additional measurements (e.g. those for TC and the ISDN-UP).

### **6.3 Existing SS No. 7 networks and their evolution to using TMN**

To interconnect existing SS No. 7 networks into a TMN-OS, the following possibilities are recommended.

#### **6.3.1 Q-Adaptation function**

A TMN-defined Q-Adaptation function may be implemented for each signalling point, possibly located within a device separate from the signalling point.

#### **6.3.2 Limitations upon the output to the TMN-OS**

Certain Q.752 Recommendations might not be satisfied when using a Q-Adaptation function. For example, where Recommendation Q.752 now recommends a five-minute measurement interval, and Recommendation Q.791 recommends 30 minutes, signalling points implemented to Recommendation Q.791 might not be able to follow Recommendation Q.752 without modification, and the Q-Adaptation function cannot provide the interval conversion. The TMN-OS should be flexible enough to accommodate this.



## 6.4 Compatibility within OMAP communication protocols

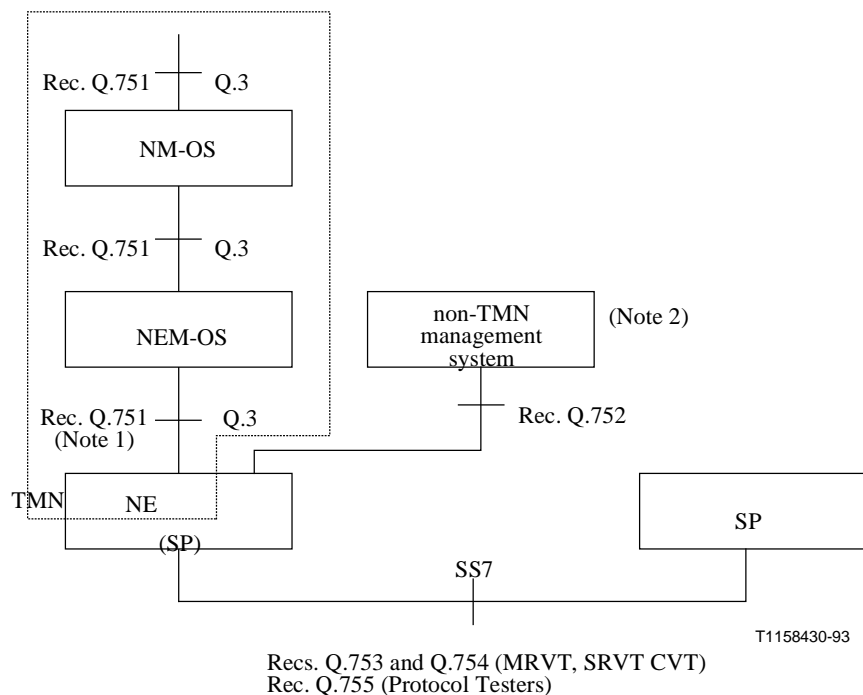
The definition of the OMAP functions MRVT, SRVT and CVT given in the 1993 version of Recommendation Q.753 includes a statement that information additional to that defined in Recommendation Q.753 and the formal definition of OMASE in Recommendation Q.754 will be ignored (this means discarded), provided that it is in the form of OPTIONAL parameters. In the later Q.753 and Q.754 Recommendations, the requirement is to pass on transparently information that is not understood, and, if appropriate and requested, to return such parameters in the MRVR and SRVR messages.

The encodings for MRVT ASEs changed between *Blue* and *White Books* because the CMIP definitions, upon which the encodings were based, changed. Consequently, an implementation to the *Blue Book* will not interwork with one to the *White Book*.

## ANNEX A

### OMAP Recommendations which apply to the TMN and SS No. 7 interfaces

This annex contains Figure A.1, showing the OMAP Recommendations which apply to the TMN and SS No. 7 interfaces used for management of the SS No. 7 network. Note that the SS No. 7 interface is used for functions that test the SS No. 7 network, and messages flowing across it are part of the behaviour of the respective managed objects.



- NM-OS Network Management Operations System (OS)
- NEM-OS Network Element Management OS
- NE Network Element
- SP Signalling Point
- - - Within this line is the TMN domain

NOTE 1 – Recommendation Q.751 references Recommendation Q.752 for measurements.

NOTE 2 – This is an implementation dependent system.

**Figure A.1/Q.750 – TMN, SS No. 7 management and OMAP Recommendations**

## ANNEX B

### **Recommendation for narrow-band SS No. 7 managed objects**

The Q.751-Series of Recommendations contain the definition of SS No. 7 managed objects.

Recommendation Q.751.1 defines the MTP network element managed objects (with some consideration for network management).

Recommendation Q.751.2 defines the SCCP network element managed objects.

Recommendation Q.751.3 defines the SS No. 7 accounting network element managed objects.

## ANNEX C

### **Management of the SS No. 7 part of broadband networks**

The management of the SS No. 7 part of broadband networks is tentatively thought to be analogous to that of narrow-band SS No. 7 networks. Certainly, the MTP-3b (see reference [8], Recommendation Q.2210) uses a superset of the MTP managed objects defined in Recommendation Q.751.1. Currently, it is intended to document the Q.2210 required managed objects in a new Recommendation (Q.2751.1), and include there the SAAL NNI managed objects (i.e. those managed objects defined to control the resources defined in Recommendation Q.2144).

#### **References**

- [1] ITU-T Recommendation M.3010 (1996), *Principles for a telecommunications management network*.
- [2] ITU-T Recommendation X.701, *Information technology – Open Systems Interconnection – Systems management overview*, and other Recommendations in this Series.
- [3] ITU-T Recommendation Q.703 (1996), *Signalling link*.  
ITU-T Recommendation Q.704 (1996), *Signalling network functions and messages*.
- [4] ITU-T Recommendation Q.714 (1996), *Signalling connection control part procedures*.
- [5] CCITT Recommendation X.731 (1992), *Information technology – Open Systems Interconnection – Systems management: State management function*.
- [6] ITU-T Recommendations Q.771-Q.775 (1997), *Transaction capabilities application part*.
- [7] ITU-T Recommendation Q.811 (1997), *Lower layer protocol profiles for the Q3 and X interfaces*.  
ITU-T Recommendation Q.812 (1997), *Upper layer protocol profiles for the Q3 and X interfaces*.
- [8] ITU-T Recommendation Q.2210 (1996), *Message transfer part MTP level 3 functions and messages, using the services of ITU-T Recommendation Q.2140*.

## ITU-T RECOMMENDATIONS SERIES

- Series A Organization of the work of the ITU-T
- Series B Means of expression: definitions, symbols, classification
- Series C General telecommunication statistics
- Series D General tariff principles
- Series E Overall network operation, telephone service, service operation and human factors
- Series F Non-telephone telecommunication services
- Series G Transmission systems and media, digital systems and networks
- Series H Audiovisual and multimedia systems
- Series I Integrated services digital network
- Series J Transmission of television, sound programme and other multimedia signals
- Series K Protection against interference
- Series L Construction, installation and protection of cables and other elements of outside plant
- Series M TMN and network maintenance: international transmission systems, telephone circuits, telegraphy, facsimile and leased circuits
- Series N Maintenance: international sound programme and television transmission circuits
- Series O Specifications of measuring equipment
- Series P Telephone transmission quality, telephone installations, local line networks
- Series Q Switching and signalling**
- Series R Telegraph transmission
- Series S Telegraph services terminal equipment
- Series T Terminals for telematic services
- Series U Telegraph switching
- Series V Data communication over the telephone network
- Series X Data networks and open system communication
- Series Z Programming languages