



INTERNATIONAL TELECOMMUNICATION UNION

# ITU-T

# Q.731

TELECOMMUNICATION  
STANDARDIZATION SECTOR  
OF ITU

(03/93)

## **SPECIFICATIONS OF SIGNALLING SYSTEM No. 7**

---

### **STAGE 3 DESCRIPTION FOR NUMBER IDENTIFICATION SUPPLEMENTARY SERVICES USING SIGNALLING SYSTEM No. 7**

**CLAUSE 3 – CALLING LINE IDENTIFICATION  
PRESENTATION (CLIP)**

**CLAUSE 4 – CALLING LINE IDENTIFICATION  
RESTRICTION (CLIR)**

**CLAUSE 5 – CONNECTED LINE IDENTIFICATION  
PRESENTATION (COLP)**

**CLAUSE 6 – CONNECTED LINE IDENTIFICATION  
RESTRICTION (COLR)**

### **ITU-T Recommendation Q.731**

(Previously “CCITT Recommendation”)

---

## FOREWORD

The ITU Telecommunication Standardization Sector (ITU-T) is a permanent organ of the International Telecommunication Union. The ITU-T is responsible for studying technical, operating and tariff questions and issuing Recommendations on them with a view to standardizing telecommunications on a worldwide basis.

The World Telecommunication Standardization Conference (WTSC), which meets every four years, established the topics for study by the ITU-T Study Groups which, in their turn, produce Recommendations on these topics.

ITU-T Recommendation Q.731, clauses 3, 4, 5 and 6, was prepared by the ITU-T Study Group XI (1988-1993) and was approved by the WTSC (Helsinki, March 1-12, 1993).

---

## NOTES

1 As a consequence of a reform process within the International Telecommunication Union (ITU), the CCITT ceased to exist as of 28 February 1993. In its place, the ITU Telecommunication Standardization Sector (ITU-T) was created as of 1 March 1993. Similarly, in this reform process, the CCIR and the IFRB have been replaced by the Radiocommunication Sector.

In order not to delay publication of this Recommendation, no change has been made in the text to references containing the acronyms "CCITT, CCIR or IFRB" or their associated entities such as Plenary Assembly, Secretariat, etc. Future editions of this Recommendation will contain the proper terminology related to the new ITU structure.

2 In this Recommendation, the expression "Administration" is used for conciseness to indicate both a telecommunication administration and a recognized operating agency.

© ITU 1994

All rights reserved. No part of this publication may be reproduced or utilized in any form or by any means, electronic or mechanical, including photocopying and microfilm, without permission in writing from the ITU.

## CONTENTS

		<i>Page</i>
3	Calling line identification presentation (CLIP) .....	1
	3.1 Definition.....	1
	3.2 Description.....	1
	3.3 Operational requirements.....	2
	3.4 Coding requirements.....	2
	3.5 Signalling requirements.....	3
	3.6 Interaction with other supplementary services .....	7
	3.7 Interactions with other networks.....	9
	3.8 Signalling flows.....	9
	3.9 Parameter values (timers) .....	9
	3.10 Dynamic description.....	9
4	Calling line identification restriction (CLIR).....	9
	4.1 Definition.....	9
	4.2 Description.....	9
	4.3 Operational requirements.....	14
	4.4 Coding requirements.....	15
	4.5 Signalling requirements.....	15
	4.6 Interaction with other supplementary services .....	16
	4.7 Interactions with other networks.....	17
	4.8 Signalling flows.....	18
	4.9 Parameter values (timers) .....	18
	4.10 Dynamic description.....	18
5	Connected line identification presentation (COLP) .....	18
	5.1 Definition.....	18
	5.2 Description.....	18
	5.3 Operational requirements.....	19
	5.4 Coding requirements.....	19
	Allowed codings for the generic number parameter .....	20
	5.5 Signalling requirements.....	20
	5.6 Interaction with other supplementary services .....	23
	5.7 Interaction with other networks .....	25
	5.8 Signalling flows.....	25
	5.9 Parameter value (timers).....	25
	5.10 Dynamic description.....	25
6	Connected line identification restriction (COLR).....	25
	6.1 Definition.....	25
	6.2 Description.....	25
	6.3 Operational requirements.....	34
	6.4 Coding requirements.....	34
	6.5 Signalling requirements.....	34
	6.6 Interaction with other supplementary services .....	36
	6.7 Interaction with other networks .....	38
	6.8 Signalling flows.....	38
	6.9 Parameter value (timers).....	38
	6.10 Dynamic description.....	38



## STAGE 3 DESCRIPTION FOR NUMBER IDENTIFICATION SUPPLEMENTARY SERVICES USING SIGNALLING SYSTEM No. 7

(Helsinki, 1993)

### 3 Calling line identification presentation (CLIP)

#### 3.1 Definition

**calling line identification presentation (CLIP)** is a supplementary service offered to the called user which provides the calling user's number, with additional address information (e.g. calling party sub-address) if any, to the called user.

#### 3.2 Description

##### 3.2.1 General description

The CLIP supplementary service is a supplementary service offered to the called user. It presents the calling user's number, with additional address information (e.g. the calling party sub-address) if any, to the called user. When provided the facility applies to all incoming calls except for when the calling user has activated the calling line identification restriction (CLIR) supplementary service (see 4) or the complete number of the calling user is not available at the destination exchange.

The calling party number may be provided by the originating local exchange or by the access signalling system of the calling user.

The calling party sub-address (if provided by the access signalling system) shall be transported transparently by the network in the access transport parameter. The network cannot be responsible for the content of this sub-address.

Information indicating that a subscriber has the CLIP supplementary service facility is available in the exchange to which the subscriber is connected to.

The stage 1 service description is given in Recommendation I.251.3, and the stage 2 functional capabilities and information flows are given in Recommendation Q.81.3. The stage 3 DSS 1 description is given in Recommendation Q.951.3. This stage 3 description of the CLIP supplementary service uses the ISDN user part protocol as defined in Recommendations Q.761-764 and Q.730.

##### 3.2.2 Specific terminology

CLIP	Calling line identification presentation
CLIR	Calling line identification restriction
ISDN	Integrated services digital network
ISUP	Integrated services digital network user part
DSS 1	Digital subscriber signalling system No. 1

**ISDN number** – A number conforming to the numbering plan and structure specified in Recommendation E.164.

**National (ISDN) number; National significant (ISDN) number** – See Recommendation E.164.

**International (ISDN) number** – See Recommendation E.164.

**Sub-address** – See Recommendation E.164.

**Served user** – It is the user of a particular ISDN number who has subscribed to the presentation of the calling line identification information in association with incoming calls. The served user is also known as the called user.

**Calling user** – It is the user that initiated an incoming call at the served user. The calling user need not have subscribed to the CLIP supplementary service.

**Default number** – A national significant ISDN number registered within the public ISDN following prior arrangement between the calling user and the public ISDN.

**Special connection arrangement** – An arrangement between a customer and a public network operator whereby customer supplied calling party numbers are not screened by the public network.

**Access signalling system** – A part in the local exchange which handles the user-network interface protocol. It also includes the screening functions.

### **3.2.3 Qualification on the applicability to telecommunication services**

See 3.2.3/I.251.

### **3.2.4 State definitions**

No specific state definitions are required.

## **3.3 Operational requirements**

### **3.3.1 Provision/withdrawal**

See 3.3.1/I.251.

### **3.3.2 Requirements on the originating network side**

Not applicable.

### **3.3.3 Requirements in the network**

No specific requirements are needed in the network.

### **3.3.4 Requirements on the terminating network side**

Not applicable.

## **3.4 Coding requirements**

- i) Coding requirements if a special connection arrangement does not apply

Subclauses 3.8/Q.763 and 3.2/Q.763 give the coding for the calling party number and the access transport parameter which are required to support this service.

The purpose of the calling party number parameter is to identify the origin of a call.

The access transport parameter transports the calling party sub-address information element as defined in 4.5.11/Q.931 which is to identify a sub-address associated with the origin of the call.

- ii) Coding requirements if a special connection arrangement applies

In addition to the coding requirements of i) above, the generic number parameter as specified in 3.20 c)/Q.763 is required.

The purpose of the generic number parameter is to transport a calling party number provided by the calling user with a special connection arrangement.

The generic number parameter is accompanied by the parameter compatibility information parameter as specified in 3.26 b)/Q.763. The procedures for the compatibility are defined in 2.9.5/Q.764.

The allowed coding for the generic number parameter is as follows:

- a) *Number qualifier indicator*

00000110      additional calling party number

- b) *Odd/even indicator*

See 3.7 a)/Q.763

- c) *Nature of address indicator*
  - 0000001 subscriber number (for national use)
  - 0000010 unknown (for national use)
  - 0000011 national (significant) number
  - 0000100 international number
- d) *Internal network number indicator/number incomplete indicator (not used)*
  - 0
- e) *Numbering plan indicator*
  - 001 ISDN (Telephony) numbering plan (Recommendation E.164)
- f) *Address presentation restricted (Pres. Restric.) indicator*
  - 00 presentation allowed
  - 01 presentation restricted
- g) *Screening indicator*
  - 00 user provided, not verified
  - 10 user provided, verified and failed (for national use)
- h) *Address signals*
  - 0000 digit 0
  - 0001 digit 1
  - 0010 digit 2
  - 0011 digit 3
  - 0100 digit 4
  - 0101 digit 5
  - 0110 digit 6
  - 0111 digit 7
  - 1000 digit 8
  - 1001 digit 9
- i) *Filler*
  - See 3.7 h)/Q.763.

## **3.5 Signalling requirements**

### **3.5.1 Activation/deactivation/registration**

Not applicable.

### **3.5.2 Invocation and operation**

#### **3.5.2.1 Actions at the originating local exchange**

##### **3.5.2.1.1 Normal operation**

All information pertaining to the CLIP supplementary service shall be inserted in the initial address message sent as part of the basic call procedures according to Recommendation Q.764.

The calling party sub-address (if provided by the access signalling system) shall be transported transparently by the network in the access transport parameter.

If the numbering plan indicator received from the access signalling system together with a calling party number is coded other than "ISDN (Telephony) numbering plan (Recommendation E.164)" or "unknown", then the calling party number received from the access signalling system shall be discarded and the processing of the call shall continue as if no calling

party number was received. If the numbering plan indicator received from the access signalling system is coded “unknown”, then the originating local exchange shall treat this value as if the value “ISDN (Telephony) numbering plan (Recommendation E.164)” was received.

If the screening indicator received from the access signalling system together with the calling party number is coded “user provided, not verified”, then the calling party number shall be entered in the generic number parameter. In this parameter, the number qualifier indicator shall be set to “additional calling party number” and the screening indicator to “user provided, not verified”. If the numbering plan indicator received is coded “ISDN (Telephony) numbering plan (Recommendation E.164)” or “unknown”, then the nature of address indicator shall be set to “international number” or “national (significant) number” as received from the access signalling system.

#### NOTES

1 As a national option, some networks may allow for the screening indicator “user provided, verified and failed”. If this screening indicator is supported, then the originating local exchange shall treat this value in the same manner as the value “user provided, not verified”.

In addition, the originating local exchange shall enter the default number associated with that access in the calling party number parameter. In this parameter, the screening indicator shall be set to “network provided” and the nature of address indicator to “national (significant) number”.

If the screening indicator received from the access signalling system together with the calling party number is coded other than “user provided, not verified”, then the originating local exchange shall enter the calling party number as received from the access signalling system in the calling party number parameter. The screening indicator of the calling party number parameter shall be set as received from the access signalling system.

2 In the latter case, allowed values for the screening indicator are “network provided” and “user provided, verified and passed”.

If no calling party number is received from the access signalling system, the originating local exchange shall enter the default number associated with that access in the calling party number parameter. The screening indicator shall be set to “network provided” and the nature of address indicator to “national (significant) number”.

The calling party number incomplete indicator of the calling party number parameter shall be set to “complete”.

The numbering plan indicator of the calling party number parameter shall be set to “ISDN (Telephony) numbering plan (Recommendation E.164)”.

The numbering plan indicator of the generic number parameter shall be set to “ISDN (Telephony) numbering plan (Recommendation E.164)” if this value or “unknown” was received from the access signalling system.

The address presentation restricted indicators of the calling party number and the generic number parameter shall both be set to the value “presentation allowed” or “presentation restricted” as received from the access signalling system.

The actions at the originating local exchange and the resulting codepoints are summarized in Table 3-1.

#### **3.5.2.1.2 Exceptional procedures**

No exceptional procedures are identified.

#### **3.5.2.2 Actions at the transit exchange**

##### **3.5.2.2.1 Normal operation**

A transit exchange shall transfer all information relating to the CLIP and CLIR supplementary services transparently to the succeeding exchange.

NOTE – In interworking with the mobile network, the mobile telephony exchange may provide the transit exchange with an international calling party number that has a country code other than the country code of the transit exchange.

##### **3.5.2.2.2 Exceptional procedures**

No exceptional procedures are identified.



TABLE 3-1/Q.731

**Calling party number, codepoints**

Information provided by the access signalling system			Information transported by the network			
Calling party number	Numbering plan	Screening indicator	Calling party number	Numbering plan	Nature of address indicator	Screening indicator
None			Calling party number parameter			
			Default number	"E.164"	"national (significant) number"	"network provided"
			No generic number parameter indicating "additional calling party number" is sent			
Any number <sup>a)</sup>	Other than "E.164" or "unknown"		Calling party number parameter			
			Default number	"E.164"	"national (significant) number"	"network provided"
			No generic number parameter indicating "additional calling party number" is sent			
Any digit sequence conforming to E.164	"E.164" or "unknown"	"network provided" or "user provided, verified and passed"	Calling party number parameter			
			Number provided by the access signalling system	"E.164"	"national (significant) number" or "international number" as provided by the access signalling system	"network provided" or "user provided, verified and passed"
			No generic number parameter indicating "additional calling party number" is sent			
Any digit sequence conforming to E.164	"E.164" or "unknown"	"user provided, not verified" <sup>b)</sup>	Calling party number parameter			
			Default number	"E.164"	"national (significant) number"	"network provided"
			Generic number parameter for "additional calling party number"			
			Number provided by the access signalling system	"E.164"	"national (significant) number" or "international number" as provided by the access signalling system	"user provided, not verified" <sup>b)</sup>
<sup>a)</sup> In this case, the calling party number received from the access signalling system shall be discarded, but the address presentation restricted indicator shall (as in all other cases) be set to the value as received from the access signalling system.						
<sup>b)</sup> As a national option, some networks may allow for the screening indicator "user provided, verified and failed". If this screening indicator is supported, then the originating local exchange shall treat this value in the same manner as the value "user provided, not verified".						

### **3.5.2.3 Actions at the outgoing international gateway exchange**

#### **3.5.2.3.1 Normal operation**

If the address presentation restricted indicator of the received calling party number parameter is set to “presentation restricted”, the outgoing international gateway exchange shall act according to the bilateral agreement between the two networks (see 4.2.1/I.251 and 4.5/I.251). If the address presentation restricted indicator of the received calling party number parameter is set to “address not available”, then the calling party number parameter shall be omitted from the initial address message. If the calling party number parameter is not sent across the international section, then the generic number parameter shall be omitted from the initial address message if its number qualifier indicates “additional calling party number”.

The exchange shall convert the calling party number conveyed in the calling party number parameter to an international number (if necessary) and set the nature of address indicator to “international number”. The address presentation restricted indicator and the screening indicator shall be transferred transparently.

If the generic number parameter is received and its number qualifier indicates “additional calling party number” and the numbering plan indicator is coded “ISDN (Telephony) numbering plan (Recommendation E.164)”, then the generic number parameter shall be treated in the same manner as the calling party number parameter.

#### NOTES

1 Without bilateral agreement for the transport of “user provided, verified and failed” numbers between networks, the generic number parameter shall be discarded if its number qualifier indicates “additional calling party number” and the screening indicator is coded “user provided, verified and failed”.

2 The address presentation restricted indicator in both the calling party number and generic number parameters are set to the same value. They can have the values “presentation allowed” or “presentation restricted” (based on the bilateral agreement).

#### **3.5.2.3.2 Exceptional procedures**

If no calling party number parameter is received from the incoming network, then no calling party number parameter shall be sent to the succeeding exchange.

If the calling party number incomplete indicator is set to “incomplete”, then no calling party number parameter shall be sent to the succeeding exchange.

### **3.5.2.4 Actions at the incoming international gateway exchange**

#### **3.5.2.4.1 Normal operation**

The exchange shall check if the country code of the calling party number is the network’s own country code. If this is the case, then the country code shall be removed. The nature of address indicator shall be set to “national (significant) number”. The address presentation restricted indicator and the screening indicator shall be transferred transparently.

NOTE – As a national option, the incoming international gateway exchange may add a prefix to the calling party number. In this case the nature of address indicator shall be set to “unknown”.

If the generic number parameter is received and its number qualifier indicates “additional calling party number” and the numbering plan indicator is coded “ISDN (Telephony) numbering plan (Recommendation E.164)”, then the generic number parameter shall be treated in the same manner as the calling party number parameter.

#### **3.5.2.4.2 Exceptional procedures**

If no calling party number parameter is received from the preceding exchange, then no calling party number parameter shall be sent to the outgoing network.

If the address presentation restricted indicator of the received calling party number parameter is set to “address not available”, then this value shall be passed on transparently. The screening indicator shall be set to “network provided”.

NOTE – As a national option, the nature of address indicator in the calling party number parameter can be set to “unknown”.

### **3.5.2.5 Actions at the destination local exchange**

#### **3.5.2.5.1 Normal operation**

When the destination local exchange receives an initial address message, basic call handling shall occur and the exchange shall send a set-up request to the access signalling system.

It is a function of the user-network interface to check whether the called user has subscribed to the CLIP supplementary service or not and not to present the calling party sub-address, where appropriate, to the user.

If the generic number parameter with a number qualifier set to “additional calling party number” is provided, then the information conveyed in this parameter shall be presented first to the access signalling system. The information conveyed in the calling party number parameter shall be sent to the access signalling system immediately following the information of the generic number parameter.

Where the generic number parameter is not provided but the calling party number parameter is present, then the information conveyed in the calling party number parameter shall be sent to the access signalling system.

All the available information shall be sent to the access signalling system.

#### **3.5.2.5.2 Exceptional procedures**

No exceptional procedures are identified.

### **3.6 Interaction with other supplementary services**

#### **3.6.1 Call waiting (CW)**

No impact on ISUP.

#### **3.6.2 Call transfer services**

No applicable interaction at this time.

#### **3.6.3 Connected line identification presentation (COLP)**

No impact on ISUP.

#### **3.6.4 Connected line identification restriction (COLR)**

No impact on ISUP.

#### **3.6.5 Calling line identification presentation (CLIP)**

Not applicable.

#### **3.6.6 Calling line identification restriction (CLIR)**

The CLIR supplementary service (see 4) shall take precedence over the CLIP supplementary service.

Depending on bilateral agreement, the originating network may restrict the information conveyed in the generic number and/or calling party number parameter from being sent to the destination network when the CLIR supplementary service is applicable.

#### **3.6.7 Closed user group (CUG)**

No impact on ISUP.

#### **3.6.8 Conference calling (CONF)**

No impact on ISUP.

#### **3.6.9 Direct dialling-in (DDI)**

No impact on ISUP.

### **3.6.10 Call diversion services (CDIV)**

#### **3.6.10.1 Call forwarding busy (CFB)**

An exchange forwarding a call shall also forward the generic number parameter (if present).

#### **3.6.10.2 Call forwarding no reply (CFNR)**

An exchange forwarding a call shall also forward the generic number parameter (if present).

#### **3.6.10.3 Call forwarding unconditional (CFU)**

An exchange forwarding a call shall also forward the generic number parameter (if present).

#### **3.6.10.4 Call deflection (CD)**

An exchange deflecting a call shall also deflect the generic number parameter (if present).

### **3.6.11 Line hunting (LH)**

No impact on ISUP.

### **3.6.12 Three-party service (3PTY)**

No impact on ISUP.

### **3.6.13 User-to-user signalling (UUS)**

#### **3.6.13.1 User-to-user signalling, service 1 (UUS1)**

No impact on ISUP.

#### **3.6.13.2 User-to-user signalling, service 2 (UUS2)**

No impact on ISUP.

#### **3.6.13.3 User-to-user signalling, service 3 (UUS3)**

No impact on ISUP.

### **3.6.14 Multiple subscriber number (MSN)**

No impact on ISUP.

### **3.6.15 Call hold (HOLD)**

No impact on ISUP.

### **3.6.16 Advice of charge (AOC)**

No impact on ISUP.

### **3.6.17 Sub-addressing (SUB)**

No impact on ISUP.

### **3.6.18 Terminal portability (TP)**

No impact on ISUP.

### **3.6.19 Completion of calls to busy subscriber (CCBS)**

No applicable interaction at this time.

### **3.6.20 Malicious call identification (MCID)**

No impact on ISUP.

### **3.6.21 Reverse charging (REV)**

No applicable interaction at this time.

### **3.6.22 Multi-level precedence and preemption (MLPP)**

No impact on ISUP.

### **3.6.23 Private numbering plan (PNP)**

No applicable interaction at this time.

### **3.6.24 International telecommunication charge card**

No applicable interaction at this time.

## **3.7 Interactions with other networks**

On calls to or via non-ISDNs or an ISUP as defined in Recommendation Q.767 where the succeeding signalling section supports only one calling party number to be carried, the information contained in the calling party number parameter shall be forwarded. The generic number parameter shall be discarded.

Interworking exchanges may generate only part of the calling line identity for inclusion in the initial address message (e.g. trunk code). This shall be indicated in the number incomplete indicator in the calling party number parameter.

On calls incoming from some non-ISDNs, the calling party number may be delivered to the destination ISDN without an indication of calling line identity restriction or the calling party number may be incomplete. In the case where there is no indication of presentation allowed or restricted, the interworking exchange shall act according to its rules and regulations. In the case where the number incomplete indicator received together with the calling party number indicates "incomplete", the information conveyed in the calling party number parameter is passed to the access signalling system.

## **3.8 Signalling flows**

No CLIP supplementary service specific signalling flow is necessary in addition to the basic call control according to Recommendation Q.764.

## **3.9 Parameter values (timers)**

No specific timers are required.

## **3.10 Dynamic description**

The dynamic description is specified in Figure 3-1 through Figure 3-4.

# **4 Calling line identification restriction (CLIR)**

This clause 4 has to be read together with the CLIP supplementary service as defined in 3. Only the procedures which can clearly be separated from the CLIP supplementary service are contained in this clause.

## **4.1 Definition**

**calling line identification restriction (CLIR)** is a supplementary service offered to the calling user to restrict presentation of the calling user's number, with additional address information (e.g. calling party sub-address) if any, to the called user.

## **4.2 Description**

### **4.2.1 General description**

The CLIR supplementary service is a supplementary service offered to the calling user to prevent presentation of the calling user's number, and additional address information (e.g. calling party sub-address) if any, to the called user.

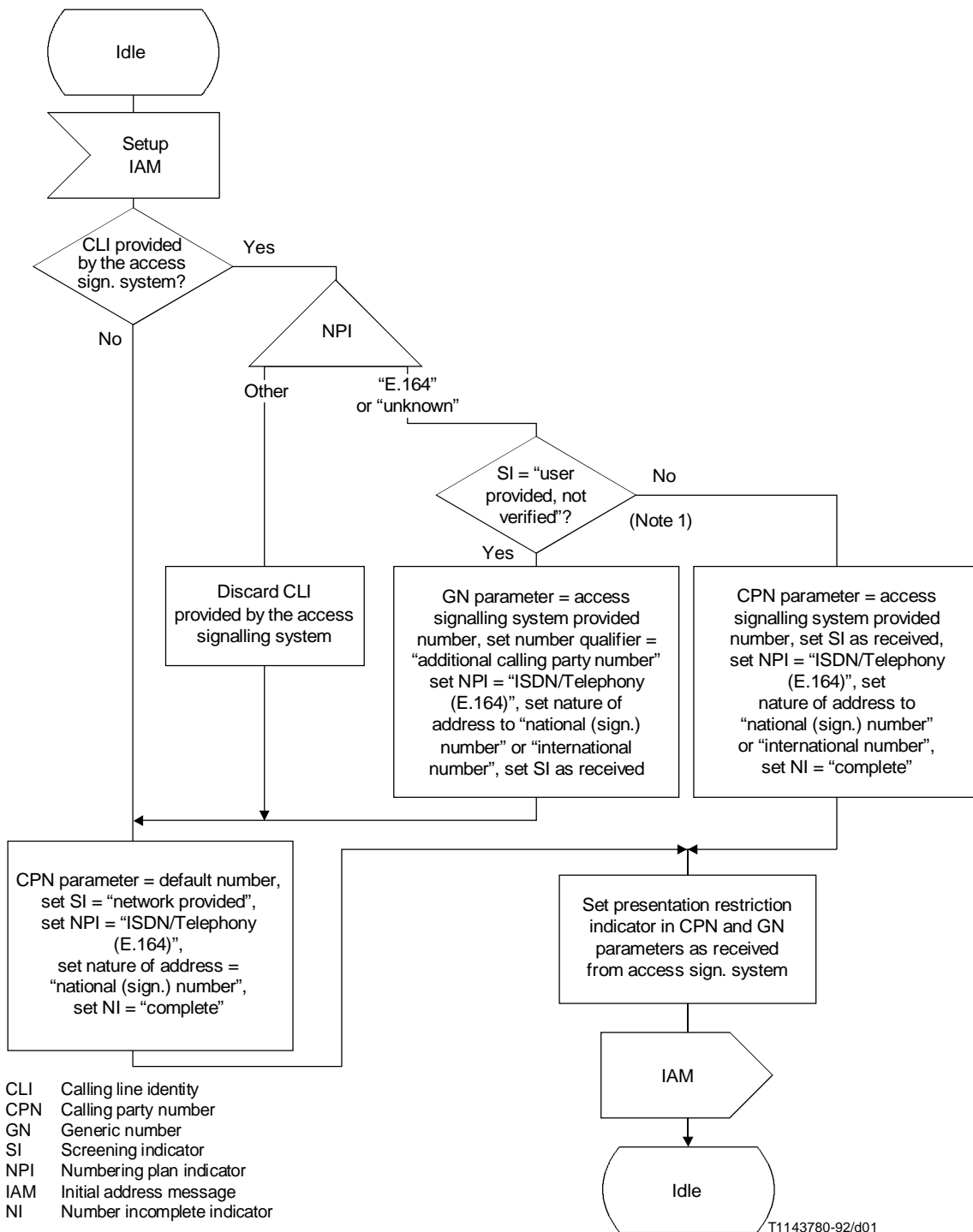

NOTES

- 1 As a national option, some networks may allow for the screening indicator "user provided and failed". If this screening indicator is supported, then the originating local exchange shall treat this value in the same manner as the value "user provided, not verified".
- 2 This procedure operates independently from any CLIP subscription by the calling user and is provided as part of the basic service.
- 3 This transition specifies additional processing to that described in Q.764. Annex H.

FIGURE 3-1/Q.731

Originating local exchange dynamic description of the ISUP protocol

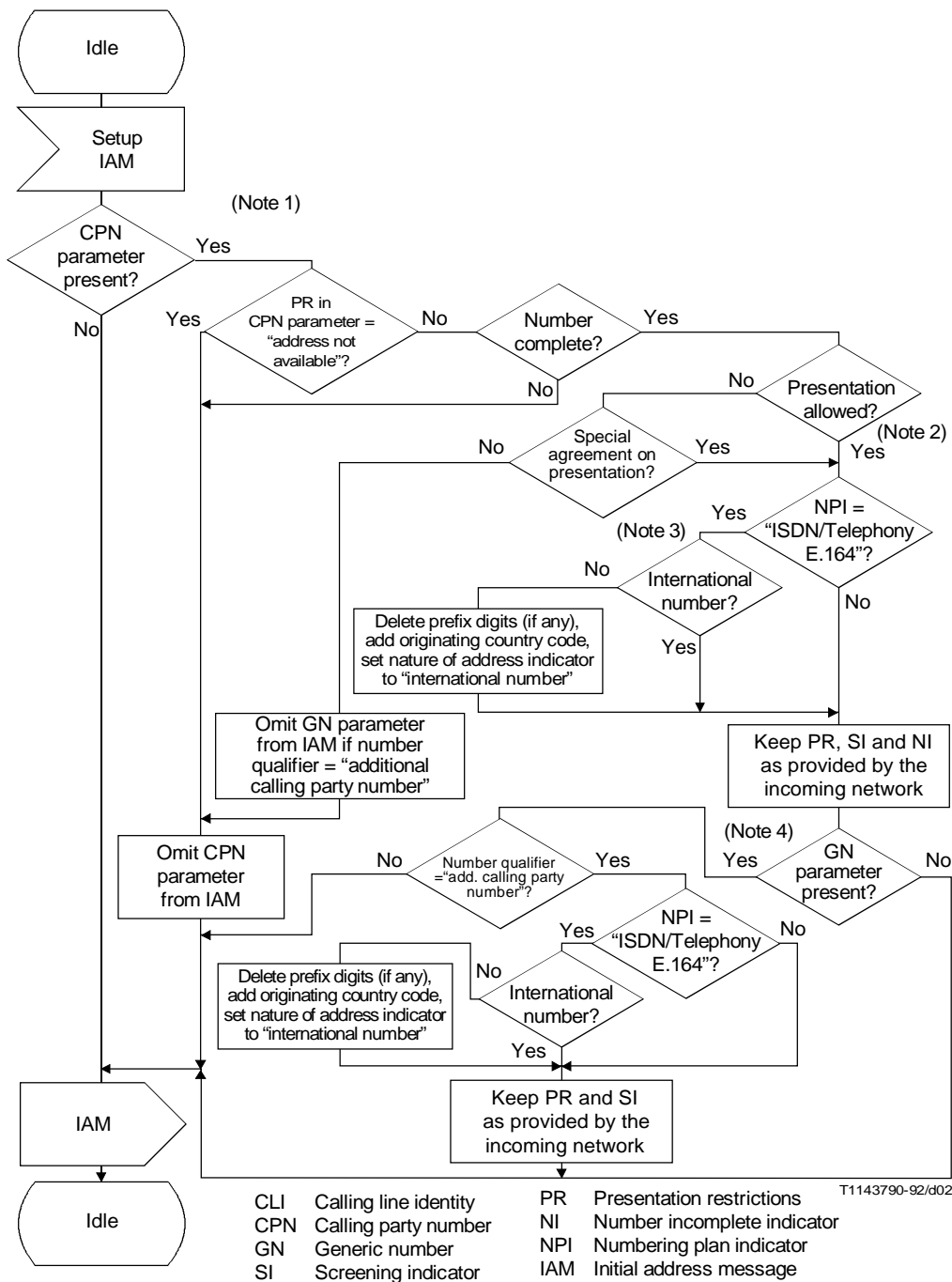

**NOTES**

- 1 This flow assumes that there is no restriction on passing non-restricted CLIs across the international boundary. If no such agreement exists then any CLI in the CPN and GN parameter of the incoming IAM will be removed.
- 2 Presentation may be restricted due to national regulations or presentation indicator. The presentation indicators shall have the value in both the CPN and GN parameter.
- 3 Based on bilateral agreement. See 4.2.1/I.251 and 4.5/I.251.
- 4 Without bilateral agreement for the transport of "user provided, verified and failed" numbers between networks, the generic number parameter shall be discarded if its number qualifier indicates "additional calling party number" and the screening indicator is coded "user provided, verified and failed".
- 5 This transition specifies additional processing to that described in Annex H/Q.764.

FIGURE 3-2/Q.731

**Outgoing international gateway exchange dynamic description**

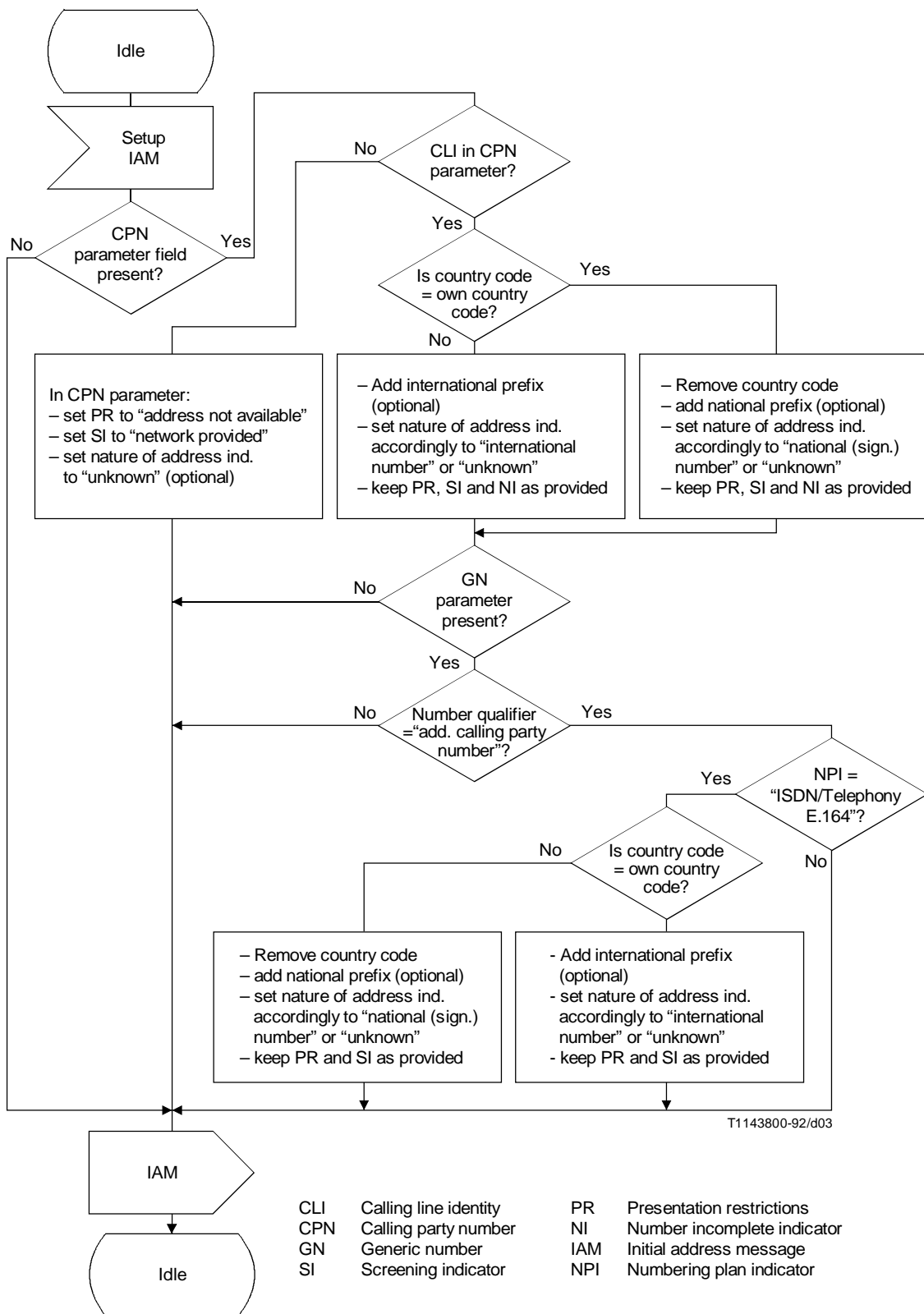

NOTE – This transition specifies additional processing to that described in Annex H/Q.764.

FIGURE 3-3/Q.731

**Incoming international gateway exchange dynamic description**



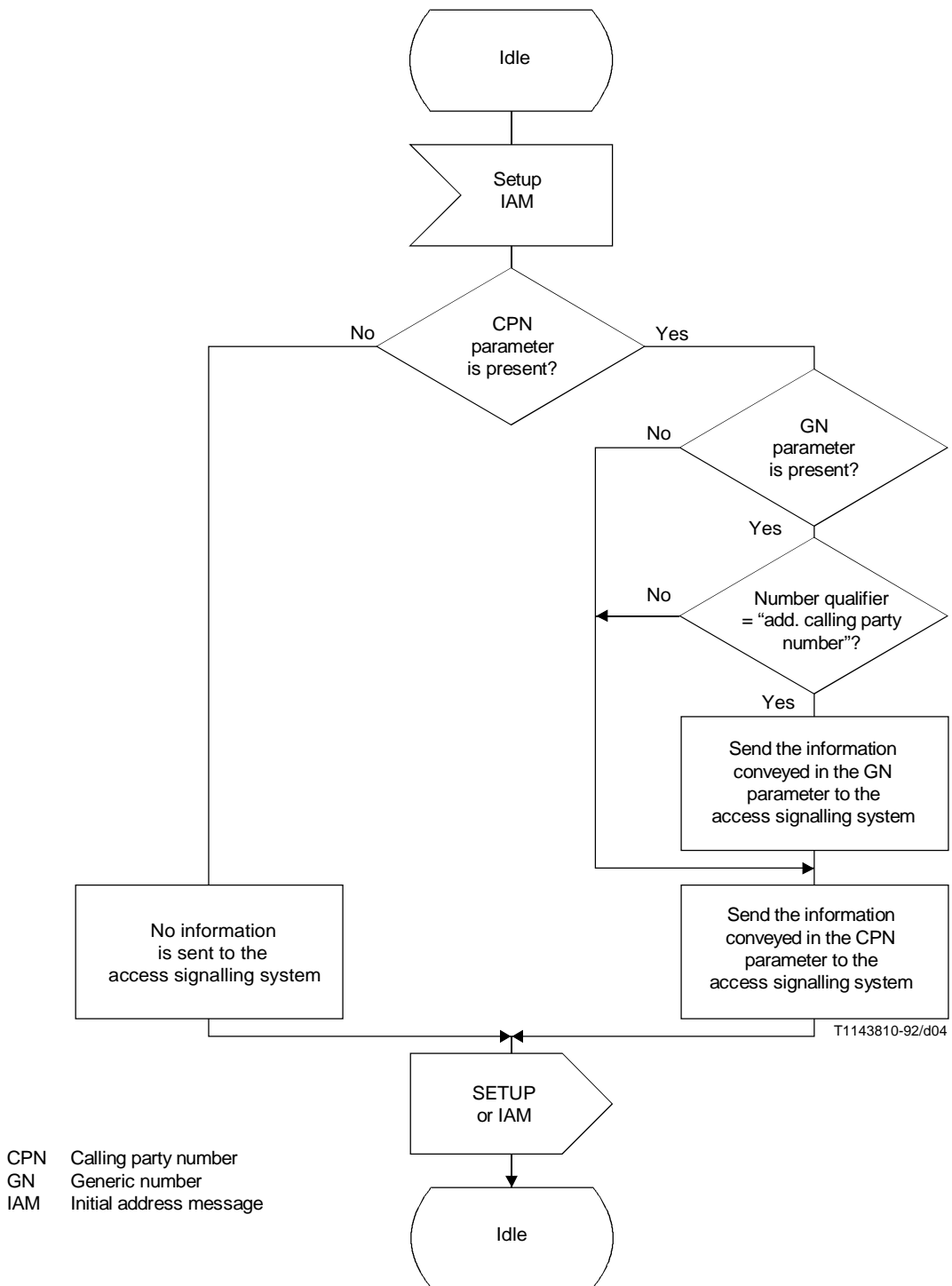

NOTES

- 1 It is a function of the access signalling system to check if the CLIP supplementary service is applicable and not to present presentation restricted numbers to the called user.
- 2 The request option is not supported by private networks (identity always included). The request procedure can only be used to obtain the calling line identity in case of Malicious call identification supplementary service.
- 3 This transition specifies additional processing to that described in Annex H/Q.764.

FIGURE 3-4/Q.731

Destination local exchange dynamic description of the ISUP protocol

When the CLIR supplementary service is applicable and activated, the originating network shall provide the destination network with a notification that the calling party number is not allowed to be presented to the called user. In this case, the calling line identity shall be marked as presentation restricted, in the address presentation restricted indicator(s) of the calling party number parameter and generic number parameter (if present), when it is passed across the network. In the case of the CLIR supplementary service the calling party's number, and sub-address (if any), shall not be included in the call offered to the called user's installation. It is a function of the user-network interface not to present the identification of the calling user to the called user if the information is marked "presentation restricted" or to override the presentation restricted indication if the called user has an override category (e.g. police).

Information indicating that a subscriber has the CLIR supplementary service facility is available in the exchange to which the subscriber is connected to.

The stage 1 service description is given in Recommendations I.251.3 and I.251.4 and the stage 2 functional capabilities and information flows are given in Recommendation Q.81.3. The stage 3 DSS 1 description is given in Recommendation Q.951.4. This stage 3 description of the CLIR supplementary service uses the ISDN user part protocol as defined in Recommendations Q.761-764 and Q.730.

#### 4.2.2 Specific terminology

CLIP	Calling line identification presentation
CLIR	Calling line identification restriction
ISDN	Integrated services digital network
ISUP	Integrated services digital network user part
DSS 1	Digital subscriber signalling system No. 1

**ISDN number** – A number conforming to the numbering plan and structure specified in Recommendation E.164.

**National (ISDN) number; National significant (ISDN) number** – See Recommendation E.164.

**International (ISDN) number** – See Recommendation E.164.

**Sub-address** – See Recommendation E.164.

**Served user** – It is the user of a particular ISDN number who has subscribed to the restriction of the calling line identification information (on a permanent or on a per-call basis) in association with outgoing calls. The served user is also known as the calling user.

**Called user** – It is the receiver of a call, initiated by the served user, on which the CLIR supplementary service has been activated.

**Default number** – A national significant ISDN number registered within the public ISDN following prior arrangement between the calling party and the public ISDN.

**Access signalling system** – A part in the local exchange which handles the user-network interface protocol. It also includes the screening functions.

#### 4.2.3 Qualification on the applicability to telecommunication services

See 4.2.3/I.251.

#### 4.2.4 State definitions

No specific state definitions are required.

### 4.3 Operational requirements

#### 4.3.1 Provision/withdrawal

See 4.3.1/I.251.

#### 4.3.2 Requirements on the originating network side

Not applicable.

### **4.3.3 Requirements in the network**

No specific requirements are needed in the network.

### **4.3.4 Requirements on the terminating network side**

Not applicable.

## **4.4 Coding requirements**

See 3.4.

## **4.5 Signalling requirements**

### **4.5.1 Activation/deactivation/registration**

Not applicable.

### **4.5.2 Invocation and operation**

#### **4.5.2.1 Actions at the originating local exchange**

##### **4.5.2.1.1 Normal operation**

The originating local exchange shall set the address presentation restricted indicator of the calling party number parameter and of the generic number parameter (if applicable) to the value as asked for by the access signalling system of the calling user.

##### **4.5.2.1.2 Exceptional procedures**

No exceptional procedures are identified.

#### **4.5.2.2 Actions at the transit exchange**

##### **4.5.2.2.1 Normal operation**

See 3.5.2.2.1.

##### **4.5.2.2.2 Exceptional procedures**

See 3.5.2.2.2.

#### **4.5.2.3 Actions at the outgoing international gateway exchange**

##### **4.5.2.3.1 Normal operation**

See 3.5.2.3.1.

##### **4.5.2.3.2 Exceptional procedures**

Depending on bilateral agreement, the originating network may restrict the information conveyed in the generic number and/or calling party number parameter(s) from being sent to the destination network when the CLIR supplementary service is applicable.

#### **4.5.2.4 Actions at the incoming international gateway exchange**

##### **4.5.2.4.1 Normal operation**

See 3.5.2.4.1.

##### **4.5.2.4.2 Exceptional procedures**

See 3.5.2.4.2.

#### **4.5.2.5 Actions at the destination local exchange**

##### **4.5.2.5.1 Normal operation**

See 3.5.2.5.1.

#### **4.5.2.5.2 Exceptional procedures**

See 3.5.2.5.2.

### **4.6 Interaction with other supplementary services**

#### **4.6.1 Call waiting (CW)**

No impact on ISUP.

#### **4.6.2 Call transfer services**

No applicable interaction at this time.

#### **4.6.3 Connected line identification presentation (COLP)**

No impact on ISUP.

#### **4.6.4 Connected line identification restriction (COLR)**

No impact on ISUP.

#### **4.6.5 Calling line identification presentation (CLIP)**

The CLIR supplementary service shall take precedence over the CLIP supplementary service.

Depending on bilateral agreement, the originating network may restrict the information conveyed in the generic number and/or calling party number parameter(s) from being sent to the destination network when the CLIR supplementary service is applicable.

#### **4.6.6 Calling line identification restriction (CLIR)**

Not applicable.

#### **4.6.7 Closed user group (CUG)**

No impact on ISUP.

#### **4.6.8 Conference calling (CONF)**

No impact on ISUP.

#### **4.6.9 Direct-dialling-in (DDI)**

No impact on ISUP.

#### **4.6.10 Call diversion services (CDIV)**

##### **4.6.10.1 Call forwarding busy (CFB)**

No impact on ISUP.

##### **4.6.10.2 Call forwarding no reply (CFNR)**

No impact on ISUP.

##### **4.6.10.3 Call forwarding unconditional (CFU)**

No impact on ISUP.

##### **4.6.10.4 Call deflection (CD)**

No impact on ISUP.

#### **4.6.11 Line hunting (LH)**

No impact on ISUP.

#### **4.6.12 Three-party service (3PTY)**

No impact on ISUP.

#### **4.6.13 User-to-user signalling (UUS)**

##### **4.6.13.1 User-to-user signalling, service 1 (UUS1)**

No impact on ISUP.

##### **4.6.13.2 User-to-user signalling, service 2 (UUS2)**

No impact on ISUP.

##### **4.6.13.3 User-to-user signalling, service 3 (UUS3)**

No impact on ISUP.

#### **4.6.14 Multiple subscriber number (MSN)**

No impact on ISUP.

#### **4.6.15 Call hold (HOLD)**

No impact on ISUP.

#### **4.6.16 Advice of charge (AOC)**

No impact on ISUP.

#### **4.6.17 Sub-addressing (SUB)**

No impact on ISUP.

#### **4.6.18 Terminal portability (TP)**

No impact on ISUP.

#### **4.6.19 Completion of calls to busy subscriber (CCBS)**

No applicable interaction at this time.

#### **4.6.20 Malicious call identification (MCID)**

When the malicious call identification supplementary service is invoked, the information conveyed in an incoming call is registered in the network regardless of whether the calling user has activated the CLIR supplementary service or not.

#### **4.6.21 Reverse charging (REV)**

No applicable interaction at this time.

#### **4.6.22 Multi-level precedence and preemption (MLPP)**

No impact on ISUP.

#### **4.6.23 Private numbering plan (PNP)**

No applicable interaction at this time.

#### **4.6.24 International telecommunication charge card**

No applicable interaction at this time.

### **4.7 Interactions with other networks**

When a call originates in one ISDN and terminates in another ISDN and the CLIR supplementary service is applied, the rules and regulations of the destination network shall apply.

NOTE – When the CLIR supplementary service is invoked, some network providers may not send the number(s) of the calling user to other network providers.

On calls to or via non-ISDNs, it cannot be assured that the address presentation restriction indication can be carried to the destination network. As a national option the originating network may restrict information identifying the calling

user from being forwarded to the destination network when the CLIR supplementary service is applicable. For further information see 3.7.

#### **4.8 Signalling flows**

No CLIR supplementary service specific signalling flow is necessary in addition to the basic call control according to Recommendation Q.764.

#### **4.9 Parameter values (timers)**

No specific timers are required.

#### **4.10 Dynamic description**

The dynamic description of the ISUP protocol relevant to the CLIR supplementary service is contained in the dynamic description of the CLIP supplementary service. For further information see 3.10.

### **5 Connected line identification presentation (COLP)**

#### **5.1 Definition**

**connected line identification presentation (COLP)** is a supplementary service offered to the calling party which provides the connected party's ISDN number, with additional address information (e.g. connected party sub-address) if any, to the calling party at the call establishment phase.

#### **5.2 Description**

##### **5.2.1 General description**

Connected line identification presentation (COLP) is a user facility that enables a user to be informed, on outgoing calls, of the address of the connected party. When provided the facility applies to all outgoing calls except for when the connected party has the connected line identity restriction (COLR) facility active.

The connected number may be provided by the destination local exchange or by the access signalling system of the connected user. If the connected party number is received from the connected user, the information is normally verified and passed to the originating exchange. If no information is received from the connected user, the destination exchange shall generate the connected number.

By special arrangement, verification of the connected party number information provided by the user may be inhibited. The information is conveyed by the network in the generic number parameter field of the answer (ANM) or connect (CON) message. The service has no impact on the signalling procedures.

The connected line identity (COL) is the ISDN number of the connected party (with additional address information, e.g. connected party sub-address, if any) which may be provided by the network or by the connected party or partially by the network with the rest provided by the connected party.

Only full international number, i.e. including the country code, should be passed across the international boundary.

Moreover, the information on the COL may include address information generated by the connected user and transparently transported by the network. The sub-address is subject to a maximum of 20 octets. The network is not responsible for the content of this additional address information.

The stage 1 CCITT definition for the COLP service is given in Recommendation I.251.5. The stage 2 CCITT description is contained in Recommendation Q.81.5. The stage 3 DSS 1 description is given in Recommendation Q.951.5. This stage 3 description of COLP and COLR uses the ISDN user part protocol as defined in Recommendations Q.761-Q.764 and Q.730.

## 5.2.2 Specific terminology

For the purpose of this Recommendation, the following definitions apply:

**ISDN number** – A number conforming to the numbering plan and structure specified in Recommendation E.164.

**Sub-address** – See 5.4/I.330.

**Served access** – It is the user of a particular ISDN number who has subscribed to the presentation of the connected line identification information in association with outgoing calls. The served user may also be known as the calling access.

**Connected access** – It is the user that receives an incoming call from the served user. The connected access need not have subscribed to the COLP supplementary service.

**Default number** – A national significant ISDN number registered within the public ISDN following prior arrangement between the connected access and the public ISDN.

**Special arrangement** – An arrangement between a customer and a public network operator whereby customer supplied connected party numbers are not screened by the public network.

**Access signalling system** – A part in the local exchange which handles the user-network interface protocol. It also includes the screening functions.

COLP Connected line identification presentation.

COLR Connected line identification restriction.

ISDN Integrated services digital network.

ISUP Integrated services digital network user part.

COL Connected line identity.

PNX Private network exchange.

## 5.2.3 Qualification on the applicability to telecommunication services

Not applicable.

## 5.2.4 State definitions

No specific state definitions are required.

## 5.3 Operational requirements

### 5.3.1 Provision/withdrawal

See 5.3.1/I.251.5.

### 5.3.2 Requirements on the originating network side

Not applicable.

### 5.3.3 Requirements in the network

No specific requirements are needed in the network.

### 5.3.4 Requirements on the terminating network side

Not applicable.

## 5.4 Coding requirements

Subclauses 3.14/Q.763, 3.25/Q.763 and 3.2/Q.763 give the coding for the connected party number, optional forward call indicators, generic number parameters and the access transport parameter fields which are required to support this service.

The purpose of the generic number parameter field is to transport a connected party number provided by the connected user with a special arrangement. This screening indicator shall be set to “user provided, not verified”.

The generic number parameter is accompanied by the parameter compatibility information parameter. The procedures for compatibility are defined in Recommendation Q.764.

### **Allowed codings for the generic number parameter**

- a) *Number qualifier indicator*
  - 00000101 additional connected party number
- b) *Odd/even indicator*
  - See 3/Q.763
- c) *Nature of address indicator*
  - 0000001 subscriber number (for national use)
  - 0000010 unknown (national use)
  - 0000011 national (significant) number
  - 0000100 international number
- d) *Internal network number indicator/number incomplete indicator*
  - 0 (not used)
- e) *Numbering plan indicator*
  - 001 ISDN (Telephony) numbering plan (Recommendation E.164)
- f) *Address presentation restricted indicator*
  - 00 presentation allowed
  - 01 presentation restricted
- g) *Screening indicator*
  - 00 user provided, not verified
- h) *Address signals*
  - 0000 digit 0
  - 0001 digit 1
  - 0010 digit 2
  - 0011 digit 3
  - 0100 digit 4
  - 0101 digit 5
  - 0110 digit 6
  - 0111 digit 7
  - 1000 digit 8
  - 1001 digit 9
- i) *Filler*
  - See 3/Q.763.

## **5.5 Signalling requirements**

### **5.5.1 Activation/deactivation/registration**

Not applicable.

### **5.5.2 Invocation and operation**

#### **5.5.2.1 Actions at the originating local exchange**

##### **5.5.2.1.1 Normal operation**

When the calling party has subscribed to the COLP facility, the exchange shall include in the optional forward call indicator in the IAM, a request to use the COLP facility for this call.



The COL information is conveyed by the network in the connected number parameter field of the answer (ANM) or connect (CON) message, unless the user has an agreement to provide unscreened information, in which case the connected number parameter field will convey the network default number, and the user provided unscreened information will be carried as received from the access signalling system in the generic number parameter also conveyed in the ANM or CON message.

When the generic number parameter field with a number qualifier set to “additional connected party number” is provided together with the connected number, then this number shall be sent in addition, to the calling access. The address presentation restricted indicator and screening indicator sent to the calling access shall be passed transparently.

When the calling party has not subscribed to the COLP facility no particular actions are required. When a request for the COL is not included in the IAM, the connected number parameter should not be included in either the answer or connect message. However, if this information is included, it shall not be considered as a protocol error and the call should continue.

It is a function of the user-network interface to check whether the calling user has subscribed to the COLP supplementary service, and not to present the COL or sub-address if no subscription exists.

#### **5.5.2.1.2 Exceptional procedures**

No exceptional procedures are identified.

#### **5.5.2.2 Actions at the transit exchange**

##### **5.5.2.2.1 Normal operation**

The transit exchange shall transparently pass on all information related to the COLP supplementary service.

##### **5.5.2.2.2 Exceptional procedures**

No exceptional procedures are identified.

#### **5.5.2.3 Actions at the outgoing international gateway exchange**

##### **5.5.2.3.1 Normal operation**

The exchange shall check if the country code of the connected party number is the network’s own country code. If this is the case then the country code shall be removed. The nature of address indicator shall be set to “national (significant) number”. The address presentation restricted indicator and the screening indicator shall be transferred transparently.

NOTE – As a national option, the outgoing international gateway exchange may add a prefix to the connected party number. In this case the nature of address indicator shall be set to “unknown”.

If the generic number parameter field is received and its number qualifier indicates “additional connected party number”, and the numbering plan indicator is coded “ISDN (Telephony) numbering plan (Recommendation E.164)”, then the generic number parameter shall be treated in the same manner as the connected party number parameter.

##### **5.5.2.3.2 Exceptional procedures**

No exceptional procedures are identified.

#### **5.5.2.4 Actions at the incoming international gateway exchange**

##### **5.5.2.4.1 Normal operation**

At the international boundary, the destination gateway can remove the COL digits if it cannot be released to the originating network and set the address presentation restricted indicator to “address not available”.

If the address presentation restricted indicator of the received connected party number parameter field is set to “presentation restricted”, the destination international gateway exchange shall act according to the bilateral agreement between the two networks. If the connected party number parameter field is not sent across the international section, then the generic number parameter field shall also be omitted from the CON or ANM message if its number qualifier indicates “additional connected party number”.

The exchange shall convert the connected party number parameter field to an international number (if necessary) and set the nature of address indicator to “international number”. The address presentation restricted indicator and the screening indicator shall be transferred transparently.

If the generic number parameter field is received and its number qualifier indicates “additional connected party number” and the numbering plan indicator is coded “ISDN (Telephony) numbering plan (Recommendation E.164)”, then the generic number parameter shall be treated in the same manner as the connected party number parameter.

#### **5.5.2.4.2 Exceptional procedures**

No exceptional procedures identified.

#### **5.5.2.5 Actions at the destination local exchange**

##### **5.5.2.5.1 Normal operation**

The exchange shall deliver the COL only if it was requested at call set-up. However, if it is included in the answer or connect message when it has not been requested it should not be considered as a protocol error and the call should be allowed to continue.

In the case where a connected party is a PNX, the network sends the ISDN number and the DDI number of the extension as the COL if the extension digits are provided by the connected party. If the extension digits are not provided the network sends the ISDN default number. The default number is stored within the network but the value is agreed between the Administration and the customer concerned.

When the COL is provided by the user or PNX, it might be verified or screened for validity by the network, i.e. the COL provided by the user is within the known number range for that user.

- i) If the user provided COL is valid the connected number parameter field contains the COL in the address signals with the screening indicator set to “user provided verified and passed”.
- ii) If the user provided COL is not valid the destination exchange inserts the default number for the address signals with the screening indicator set to “network provided”.
- iii) If the user has a special arrangement with the network, that the user provided COL is not screened, then the destination local exchange shall disregard any value of the screening indicator, if received from the connected access.

The connected party number received from the called access shall be entered in the generic number parameter field. In this parameter field, the number qualifier indicator shall be set to “additional connected party number”, the screening indicator set to “user provided, not verified”. The numbering plan indicator is coded “ISDN (Telephony) numbering plan (Recommendation E.164)” if the numbering plan indicator received from the access signalling system indicates “unknown”. The nature of address indicator shall be set to “international number” or “national (significant) number” as received from the connected access.

In addition, the destination local exchange shall enter the default number associated with the connected user in the connected party number parameter field. In this parameter field, the screening indicator shall be set to “network provided” and the nature of address indicator to “national (significant) number”.

- iv) If there is no agreement and the user provided COL is not valid, the originating exchange defaults to the network provided COL for the address signals of the connected number parameter field with the screening indicator set to “network provided”.

Optionally a connected party sub-address may be included, if received from the called access, in the connected sub-address information element which is transported in the access transport parameter.

If the COL cannot be transferred (because it is not allowed to be passed or because the national network cannot provide the number) then the connected number parameter should be included in the ANM or CON messages with the indication “presentation restricted” or “address not available” set as appropriate in the address presentation restriction indicator and set the screening indicator to “network provided”.

The numbering plan indicator of the connected party number parameter field shall be set to “ISDN (Telephony) numbering plan (Recommendation E.164)”.

The numbering plan indicator of the generic number parameter field shall be set to “ISDN (Telephony) numbering plan (Recommendation E.164)” if the numbering plan indicator received from the access signalling system indicates “unknown”.

The address presentation restricted indicators of the connected party number and the generic number parameter fields shall be set to “presentation allowed” or “presentation restricted” as received from the access signalling system.

#### **5.5.2.5.2 Exceptional procedures**

No exceptional procedures are identified.

### **5.6 Interaction with other supplementary services**

#### **5.6.1 Call waiting (CW)**

No impact on ISUP.

#### **5.6.2 Call transfer services**

No applicable interaction at this time.

#### **5.6.3 Connected line identification presentation (COLP)**

Not applicable.

#### **5.6.4 Connected line identification restriction (COLR)**

The COLR supplementary service shall take precedence over the COLP supplementary service.

The COLP supplementary service can take precedence over the COLR supplementary service when the calling access has an override category. This is a national option.

#### **5.6.5 Calling line identification presentation (CLIP)**

No impact on ISUP.

#### **5.6.6 Calling line identification restriction (CLIR)**

No impact on ISUP.

#### **5.6.7 Closed user group (CUG)**

No impact on ISUP.

#### **5.6.8 Conference calling (CONF)**

No impact on ISUP.

#### **5.6.9 Direct dialling-in (DDI)**

No impact on ISUP.

#### **5.6.10 Call diversion services**

##### **5.6.10.1 Call forwarding busy (CFB)**

No impact on ISUP.

##### **5.6.10.2 Call forwarding no reply (CFNR)**

No impact on ISUP.

##### **5.6.10.3 Call forwarding unconditional (CFU)**

No impact on ISUP.

##### **5.6.10.4 Call deflection (CD)**

No impact on ISUP.

#### **5.6.11 Line hunting (LH)**

No impact on ISUP.

#### **5.6.12 Three party service (3PTY)**

No impact on ISUP.

#### **5.6.13 User-to-user signalling (UUS)**

##### **5.6.13.1 User-to-user signalling, service 1 (UUS1)**

No impact on ISUP.

##### **5.6.13.2 User-to-user signalling, service 2 (UUS2)**

No impact on ISUP.

##### **5.6.13.3 User-to-user signalling, service 3 (UUS3)**

No impact on ISUP.

#### **5.6.14 Multiple subscriber number (MSN)**

If the multiple subscriber number supplementary service is applicable to the public network access interface of the connected party, then this party can provide the appropriate connected party multiple subscriber number digits or full ISDN number on call answer. If no special arrangement has been made with the connected subscriber, then the network shall check the user provided connected party number information for validity on the corresponding access. If the check fails or if no connected number information is provided by the user, then the network shall apply the default number of the connected number.

If the multiple subscriber number supplementary service is applicable to the public network access interface of the calling access, then neither supplementary service shall affect the operation of the other supplementary service.

#### **5.6.15 Call hold (HOLD)**

No impact on ISUP.

#### **5.6.16 Advice of charge (AOC)**

No impact on ISUP.

#### **5.6.17 Sub-addressing (SUB)**

No impact on ISUP.

#### **5.6.18 Terminal portability (TP)**

No impact on ISUP.

#### **5.6.19 Completion of calls to busy subscriber (CCBS)**

No applicable interaction at this time.

#### **5.6.20 Malicious call identification (MCID)**

No impact on ISUP.

#### **5.6.21 Reverse charging (REV)**

No applicable interaction at this time.

#### **5.6.22 Multi-level precedence and preemption (MLPP)**

No impact on ISUP.

#### **5.6.23 Private numbering plan (PNP)**

No applicable interaction at this time.

#### **5.6.24 Charge card**

No applicable interaction at this time.

#### **5.7 Interaction with other networks**

On calls from ISDN networks where the preceding signalling section supports only one connected party number to be carried, the information contained in the connected party number parameter field shall be returned. The generic number parameter field shall be discarded.

On calls incoming from non-ISDNs, the COL will be discarded, if received.

On a call where COL has been requested, to networks not supporting the service, the request will be discarded.

#### **5.8 Signalling flows**

Indicated in Figures 5-1 to 5-4.

#### **5.9 Parameter value (timers)**

No specific timers are required.

#### **5.10 Dynamic description**

The dynamic description is specified in Figures 5-5 to 5-8.

### **6 Connected line identification restriction (COLR)**

This Recommendation has to be read together with the COLP supplementary service as defined in 5. Only the procedures which can clearly be separated from the COLP supplementary service are indicated.

#### **6.1 Definition**

**connected line identification restriction (COLR)** is a supplementary service offered to the connected party to restrict presentation of the connected party's ISDN-number, with additional address information (e.g. connected party sub-address) if any, to the calling party.

#### **6.2 Description**

##### **6.2.1 General description**

Connected line identification restriction (COLR) is a user facility offered to restrict the presentation of the COL to the calling party. The information that the called subscriber has the COLR facility is available at the call terminating exchange.

When COLR is applicable and activated the destination exchange shall provide the originating node with a notification that the connected user's ISDN number and any sub-address information is not allowed to be presented to the calling user. In this case the connected line identity shall be marked as presentation restricted, in the address presentation restricted indicator(s) of the connected party number parameter field and the generic number parameter field (if present), when it is passed across the network. When COLR supplementary service is activated the connected party number(s), and sub-address (if any), shall not be passed on to the calling access.

The presentation restriction function does not influence the forwarding of the connected number within the network as part of the basic service procedure.

The passing of restricted connected line identities between participating Administrations shall be subject to bilateral agreement.

The stage 1 definition for the COLR services is given in Recommendation I.251.6. The stage 2 description is contained in 6/Q.81. The stage 3 DSS 1 description is given in Recommendation Q.951.6. This stage 3 description of COLR uses the ISDN user part protocol as defined in Recommendations Q.761-Q.764, and Q.730.

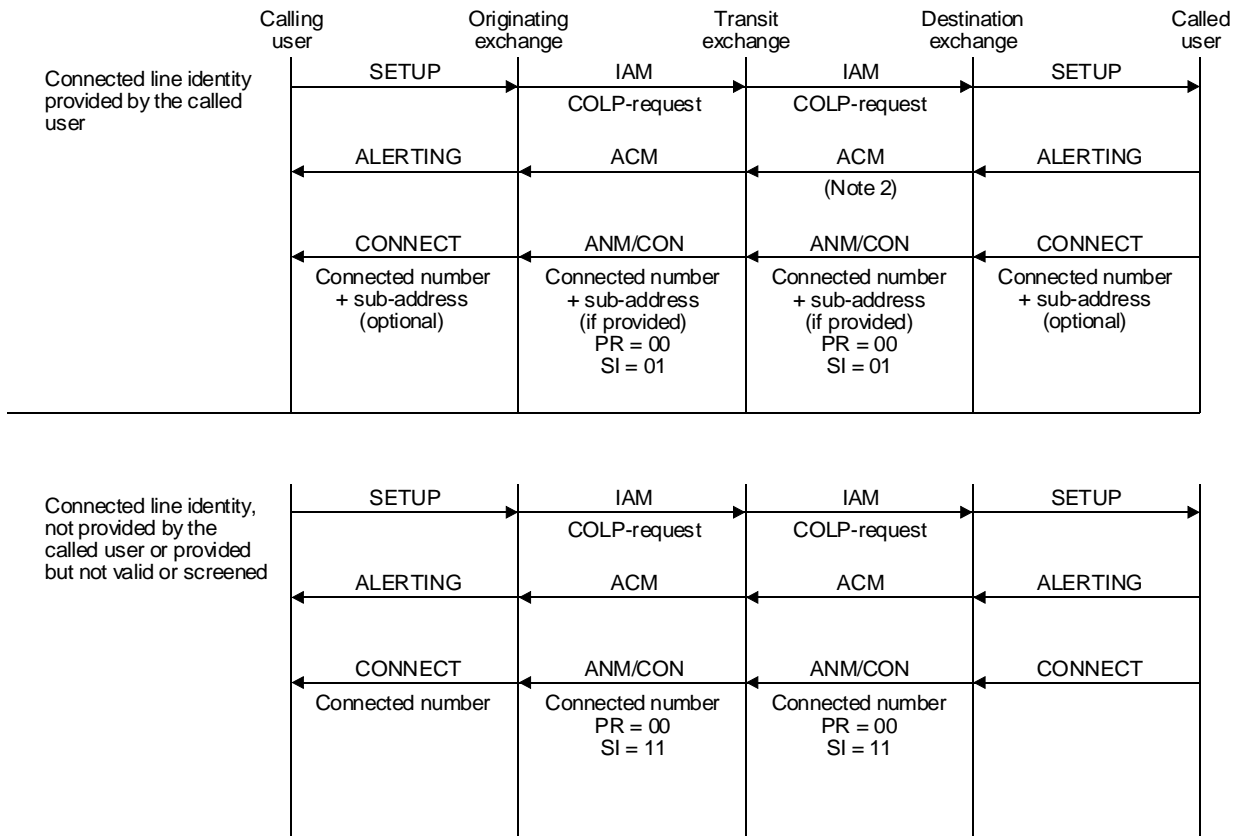

T1 138830-91/d05

NOTES

- 1 This service subscribed by the calling user and the request is included by originating exchange.
- 2 The connect message is appropriate only if the answer condition is detected prior to the return of the address complete message.

FIGURE 5-1/Q.731  
**Connected line identification presentation**

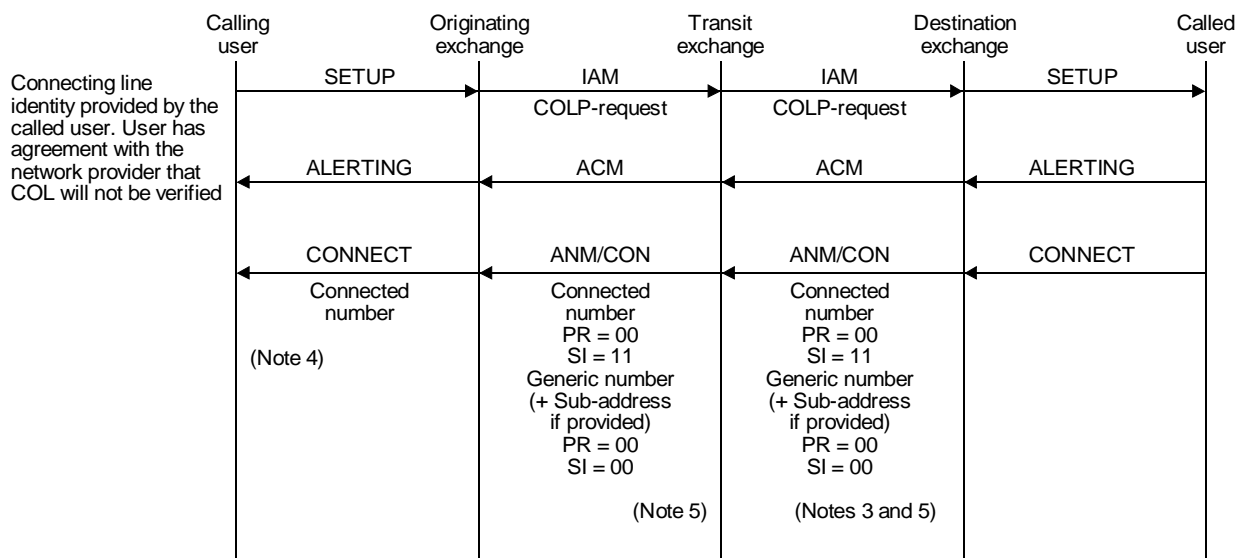

T1138840-91/d06

**NOTES**

- 1 This service is subscribed by the calling user and the request is included by the originating exchange.
- 2 The connect message is appropriate only if the answer condition is detected prior to the return of the address complete message.
- 3 It is the responsibility of the calling party access or private network ISDN to determine which COL to present to the calling user.
- 4 If the setting of the presentation restriction indicator in the connected number parameter is in conflict with the setting of the presentation restriction indicator in the generic number, the presentation will be assumed to be restricted.
- 5 Subaddress is conveyed in the ATP.

**FIGURE 5-2/Q.731**  
**Connected line identification presentation**

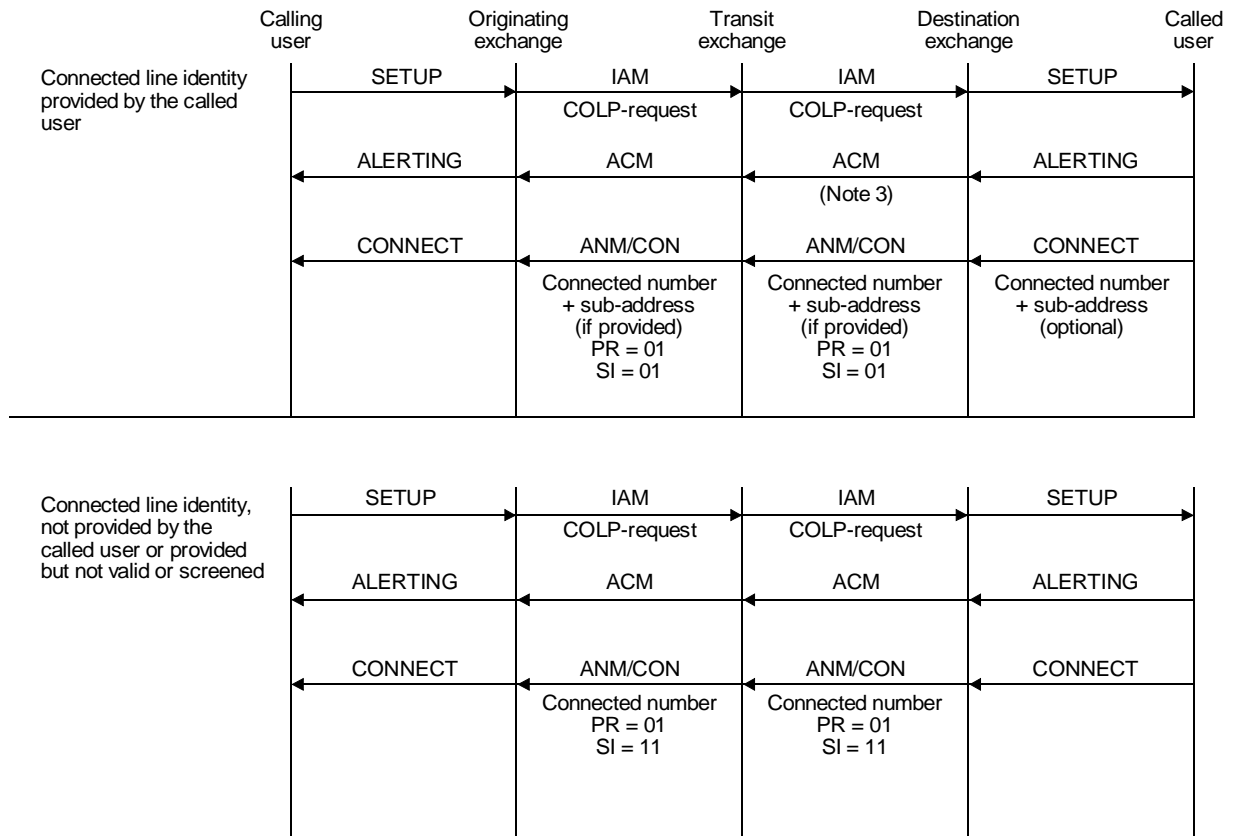

T1138850-91/d07

NOTES

- 1 This service subscribed by the calling user and the request is included by the originating exchange.
- 2 This service is subscribed by the called user and stored at the destination exchange.
- 3 The connect message is appropriate only if the answer condition is detected prior to the return of the address complete message.

FIGURE 5-3/Q.731  
Connected line identification restriction



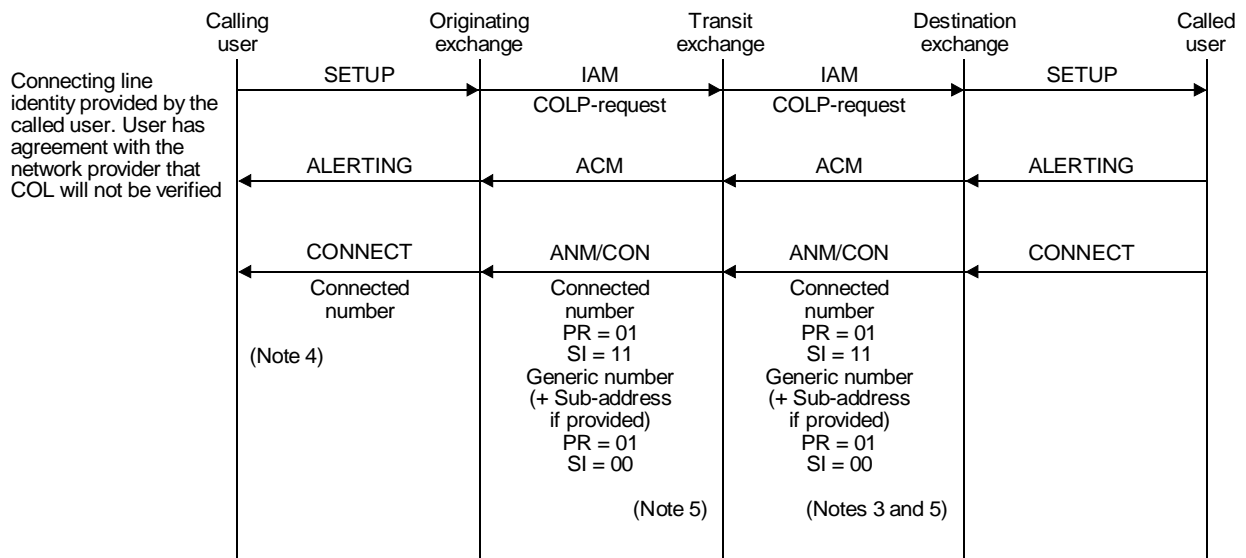

T1138860-91/d08

NOTES

- 1 This service is subscribed by the calling user and the request is included by the originating exchange.
- 2 The connect message is appropriate only if the answer condition is detected prior to the return of the address complete message.
- 3 It is the responsibility of the calling party access or private network ISDN to determine which COL to present to the calling user.
- 4 If the setting of the presentation restriction indicator in the connected number parameter is in conflict with the setting of the presentation restriction indicator in the generic number, the presentation will be assumed to be restricted.
- 5 Sub-address is conveyed in the ATP.

FIGURE 5-4/Q.731  
Connected line identification restriction

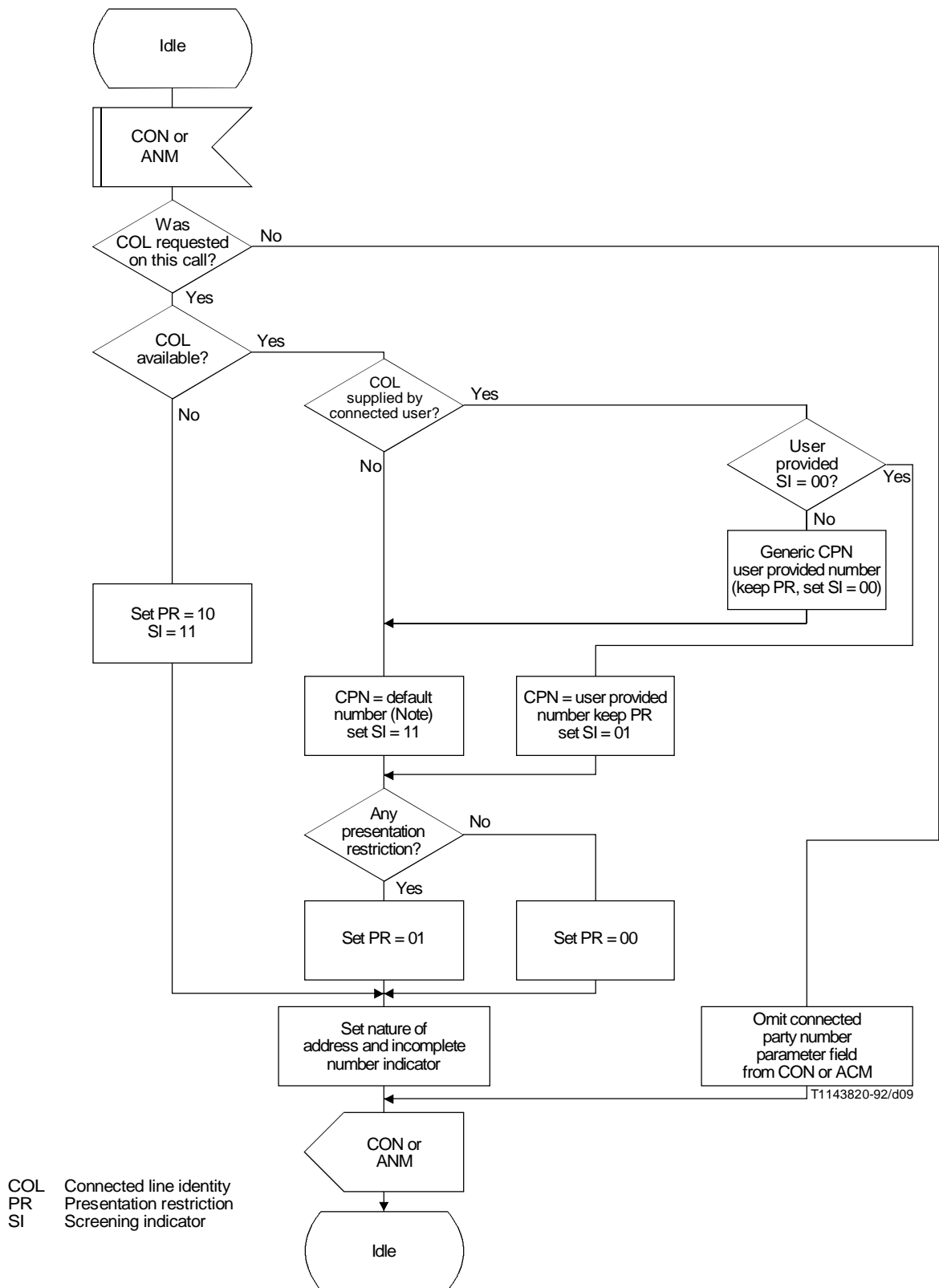

NOTE – The default number is a network supplied default number.

FIGURE 5-5/Q.731  
Nodal signalling functions for COLP and COLR  
Destination local exchange

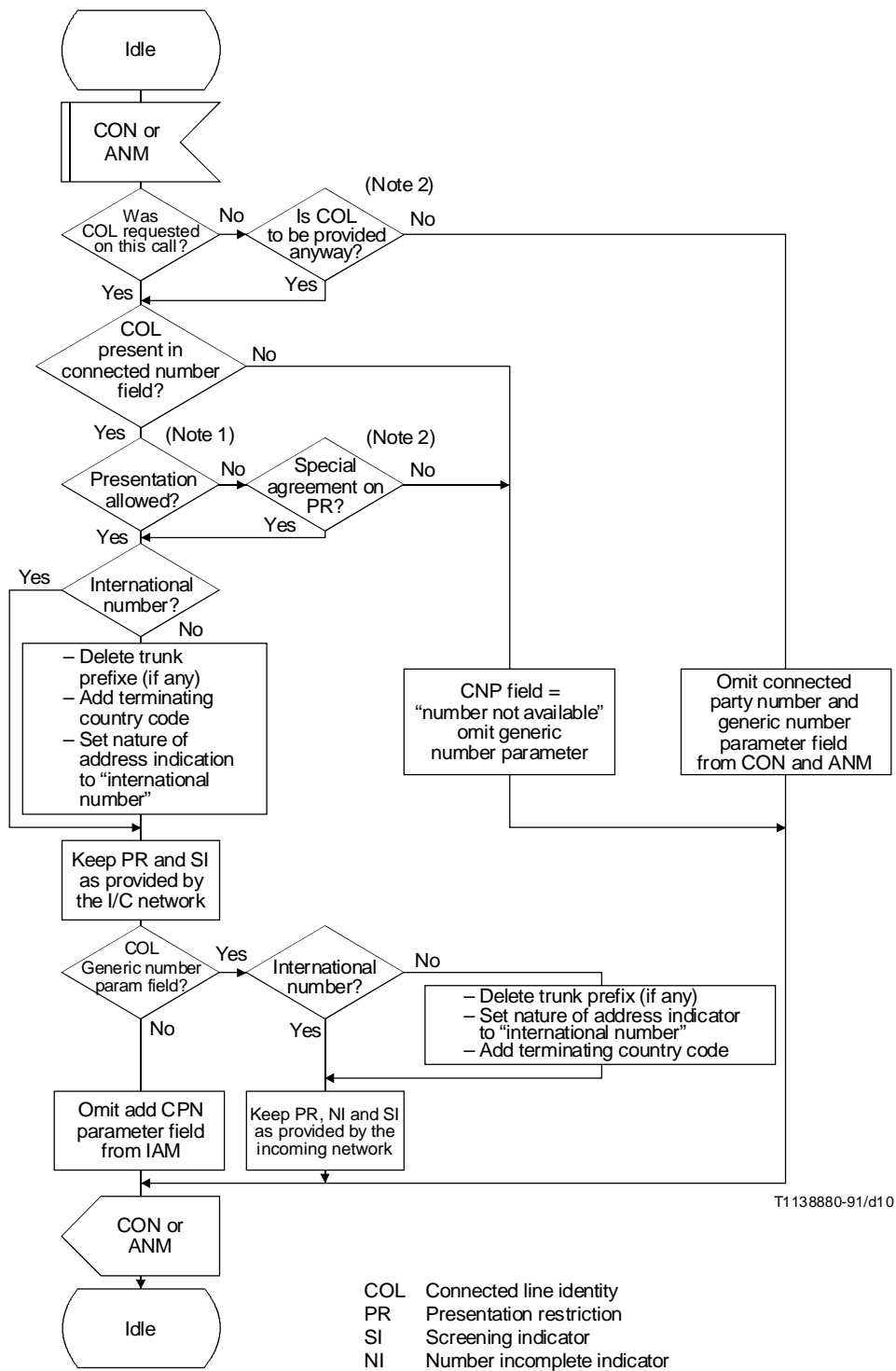

**NOTES**

- 1 This flow assumes that there is no restriction on passing non-restricted COL's across the international boundary. If no such agreement exists then any COL in the incoming CON or ANM will be removed and the PR indicator set to 10, "COL not available".
- 2 Based on bilateral agreement.

**FIGURE 5-6/Q.731**  
**Nodal signalling functions for COLP and COLR**  
**Incoming international gateway**

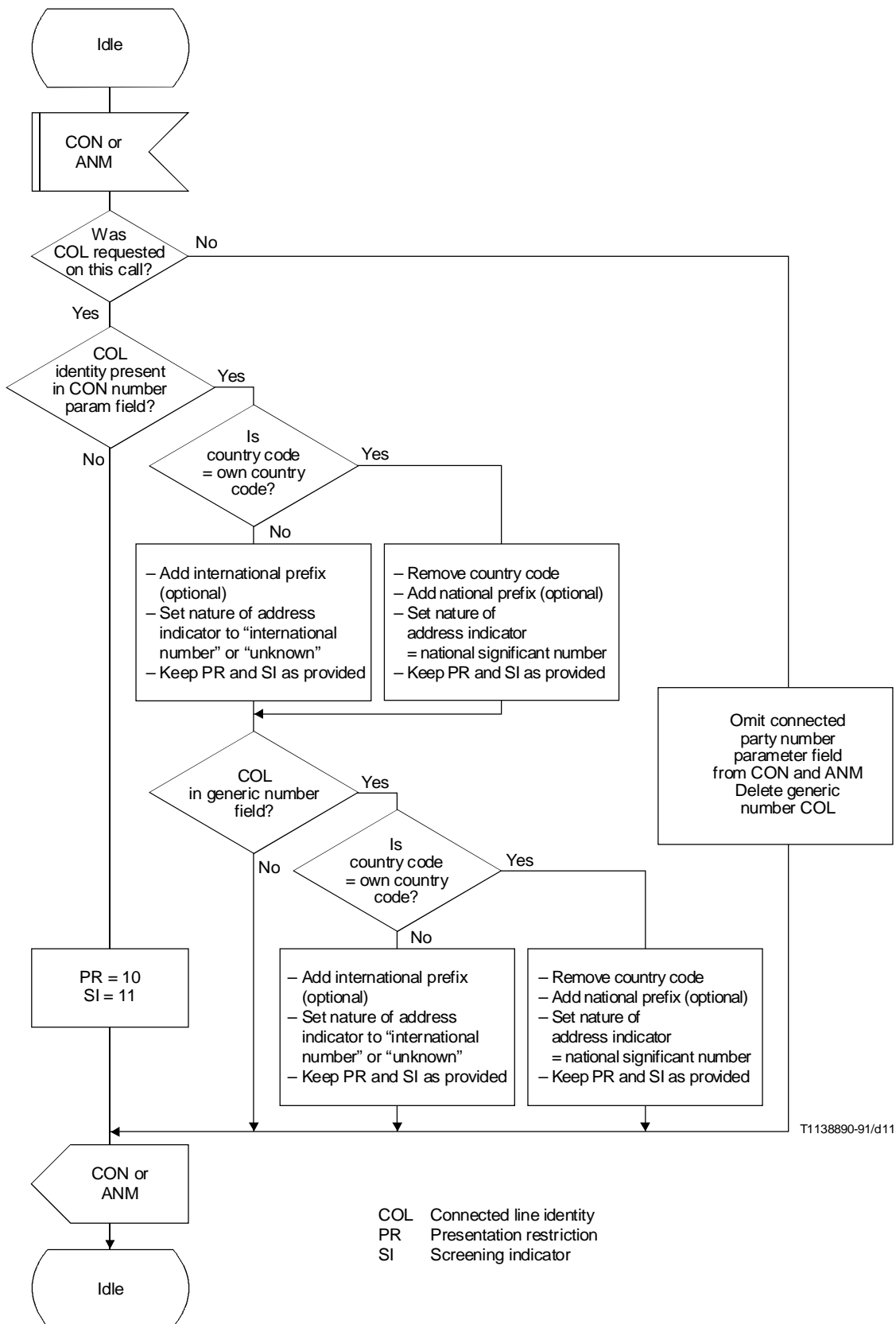
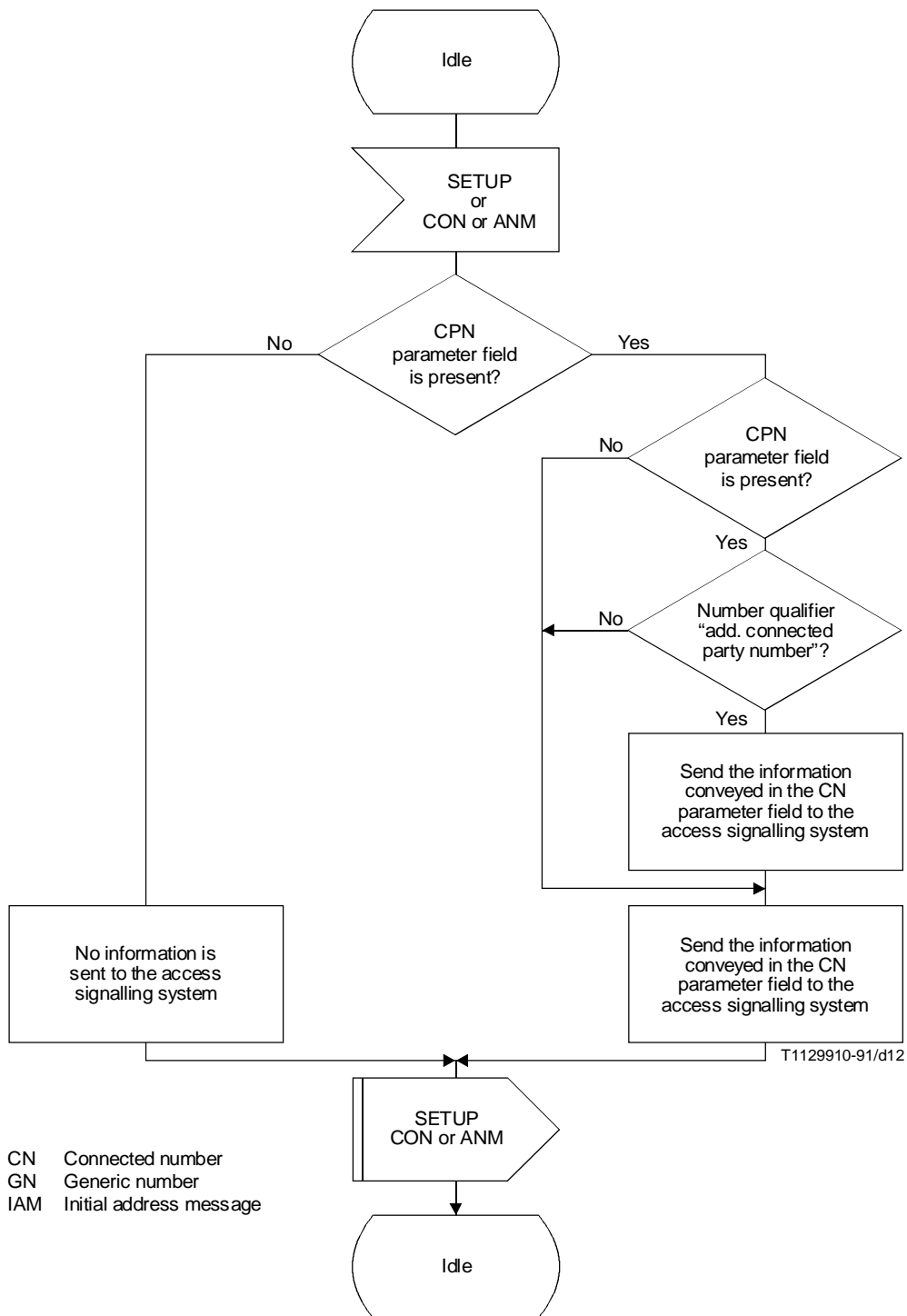

FIGURE 5-7/Q.731  
Nodal signalling functions for COLP and COLR  
Outgoing international gateway exchange



**NOTES**

- 1 It is a function of the access signalling system to check if the COLP supplementary service is applicable and not to present presentation restricted numbers to the calling user.
- 2 The request option is not supported by private networks (identity always included). The request procedure can only be used to obtain the connected line identity.
- 3 This transition specifies additional processing to that described in Annex B/Q.764.

**FIGURE 5-8/Q.731**  
**Originating local exchange**

## 6.2.2 Specific terminology

**ISDN number** – A number conforming to the numbering plan and structure specified in Recommendation E.164.

**Sub-address** – See Recommendation E.164.

**Served access** – It is the user of a particular ISDN number who has subscribed to the restriction of the connected line identification information in association with incoming calls. The served user may also be known as the connected user.

**Calling access** – It is the user that initiates an incoming call at the served user. The calling access need not have subscribed to the COLP supplementary service.

**Default number** – A national significant ISDN number registered within the public ISDN following prior arrangement between the connected access and the public ISDN.

**Special arrangement** – An arrangement between a customer and a public network operator whereby customer supplied connected party numbers are not screened by the public network.

COLP Connected line identification presentation.

COLR Connected line identification restriction.

ISDN Integrated services digital network.

ISUP Integrated services digital network user part.

## 6.2.3 Qualification on the applicability to telecommunication services

See Recommendation I.251.6.

## 6.2.4 State definitions

No specific state definitions are identified.

## 6.3 Operational requirements

### 6.3.1 Provision/withdrawal

See 6.3.1/I.251.

### 6.3.2 Requirements on the originating network side

Not applicable.

### 6.3.3 Requirements in the network

No specific requirements are needed in the network.

### 6.3.4 Requirements on the terminating network side

Not applicable.

## 6.4 Coding requirements

See 5.4.

## 6.5 Signalling requirements

### 6.5.1 Activation/deactivation/registration

Not applicable.

## **6.5.2 Invocation and operation**

### **6.5.2.1 Actions at the originating local exchange**

#### **6.5.2.1.1 Normal operation**

If the connected party has subscribed to the COLR facility, the destination exchange will send the connected line identity to the originating exchange if requested, with an indication that the presentation is restricted (address presentation restricted indicator set to “presentation restricted”).

This information is conveyed by the network in the connected number parameter field of the ANM or CON messages. The service has no impact on the signalling procedures.

At the originating exchange, when a connected party number is received in the ANM or CON message, the information will be passed on to the access signalling system.

It is a function of the user-network interface not to present the identification of the connected access to the calling access if the information is marked “presentation restricted”.

#### **6.5.2.1.2 Exceptional procedures**

As a national option the originating exchange can override the presentation restriction indication and the COL is then presented to the calling subscriber for specific calling access’s categories (e.g. Police).

### **6.5.2.2 Actions at the transit exchange**

#### **6.5.2.2.1 Normal operation**

No particular actions are required at intermediate exchanges. All information received regarding the COLR service will be passed on transparently.

#### **6.5.2.2.2 Exceptional procedures**

No exceptional procedures are identified.

### **6.5.2.3 Actions at the outgoing international gateway exchange**

#### **6.5.2.3.1 Normal operation**

See 5.5.2.3.1.

#### **6.5.2.3.2 Exceptional procedures**

No exceptional procedures are identified.

### **6.5.2.4 Actions at the incoming international gateway exchange**

#### **6.5.2.4.1 Normal operation**

If the address presentation restricted indicator of the received connected party number parameter field is set to “presentation restricted”, the destination international gateway exchange shall act according to the bilateral agreement between the two networks. If the connected party number parameter field is not sent across the international section, then the generic number parameter field shall be omitted from the ANM or the CON messages if its number qualifier indicates “additional connected party number”.

At the international boundary, the destination gateway can remove the COL if it cannot be released to the originating network and change the address presentation restricted indicator, set to “presentation restricted”, into “address not available”.

#### **6.5.2.4.2 Exceptional procedures**

No exceptional procedures identified.

## **6.5.2.5 Actions at the destination local exchange**

### **6.5.2.5.1 Normal operation**

When COLR is applicable and activated the destination exchange provides the originating local exchange with a notification that the connected access's ISDN number and any sub-address information is not allowed to be presented to the calling access.

The destination local exchange shall set the address presentation restriction indicator of the connected number parameter field and that of the generic number parameter field (if applicable) to the value as asked for by the access signalling system of the connected user.

Any additional address information provided by the connected party, e.g. connected party sub-address, will also be subject to the COLR supplementary service as indicated in the address presentation restriction indicator in the connected number parameter, and the generic number parameter.

### **6.5.2.5.2 Exceptional procedures**

No exceptional procedures identified.

## **6.6 Interaction with other supplementary services**

### **6.6.1 Call waiting (CW)**

No impact on ISUP.

### **6.6.2 Call transfer services**

No applicable interaction at this time.

### **6.6.3 Connected line identification presentation (COLP)**

COLR will take precedence over COLP.

The only occasion when a user subscribing to connected line identification presentation can take precedence over connected line identification restriction is when the user has an override category. This is a national option.

### **6.6.4 Connected line identification restriction (COLR)**

Not applicable.

### **6.6.5 Calling line identification presentation (CLIP)**

No impact on ISUP.

### **6.6.6 Calling line identification restriction (CLIR)**

No impact on ISUP.

### **6.6.7 Closed user group (CUG)**

No impact on ISUP.

### **6.6.8 Conference calling (CONF)**

No impact on ISUP.

### **6.6.9 Direct dialling-in (DDI)**

No impact on ISUP.

### **6.6.10 Call diversion services**

#### **6.6.10.1 Call forwarding busy (CFB)**

No impact on ISUP.

#### **6.6.10.2 Call forwarding no reply (CFNR)**

No impact on ISUP.



**6.6.10.3 Call forwarding unconditional (CFU)**

No impact on ISUP.

**6.6.10.4 Call deflection (CD)**

No impact on ISUP.

**6.6.11 Line hunting (LH)**

No impact on ISUP.

**6.6.12 Three party service (3PTY)**

No impact on ISUP.

**6.6.13 User-to-user signalling (UUS)**

**6.6.13.1 User-to-user signalling, service 1 (UUS1)**

No impact on ISUP.

**6.6.13.2 User-to-user signalling, service 2 (UUS2)**

No impact on ISUP.

**6.6.13.3 User-to-user signalling, service 3 (UUS3)**

No impact on ISUP.

**6.6.14 Multiple subscriber number (MSN)**

No impact on ISUP.

**6.6.15 Call hold (HOLD)**

No impact on ISUP.

**6.6.16 Advice of charge (AOC)**

No impact on ISUP.

**6.6.17 Sub-addressing (SUB)**

No impact on ISUP.

**6.6.18 Terminal portability (TP)**

No impact on ISUP.

**6.6.19 Completion of calls to busy subscriber (CCBS)**

No applicable interaction at this time.

**6.6.20 Malicious call identification (MCID)**

No impact on ISUP.

**6.6.21 Reverse charging (REV)**

No applicable interaction at this time.

**6.6.22 Multi-level precedence and preemption (MLPP)**

No impact on ISUP.

**6.6.23 Private numbering plan (PNP)**

No applicable interaction at this time.

**6.6.24 Charge card**

No applicable interaction at this time.

## **6.7 Interaction with other networks**

When a call originates in one ISDN network and terminates in another ISDN network and COLR is applicable, the rules and regulations of the originating (host) network shall apply.

For example, if an override category is not available in the destination network but is available in the originating network, the originating network can still override the presentation restriction whenever COL is available at this network.

As a national option the destination network can restrict the COL to the originating network if COLR is applicable.

For internetwork calls, when the COLR supplementary service is invoked, the destination network shall provide the originating network with a notification that the ISDN number of the connected party and the sub-address information (if any) is not allowed to be presented to the calling access.

## **6.8 Signalling flows**

The dynamic description for the COLR supplementary service is contained in the COLP supplementary service.

## **6.9 Parameter value (timers)**

No specific timers are required.

## **6.10 Dynamic description**

See 5.10.