



INTERNATIONAL TELECOMMUNICATION UNION

ITU-T

TELECOMMUNICATION
STANDARDIZATION SECTOR
OF ITU

Q.551

(11/96)

SERIES Q: SWITCHING AND SIGNALLING

Digital exchanges – Transmission characteristics

**Transmission characteristics of digital
exchanges**

ITU-T Recommendation Q.551

(Previously CCITT Recommendation)

ITU-T Q-SERIES RECOMMENDATIONS
SWITCHING AND SIGNALLING

SIGNALLING IN THE INTERNATIONAL MANUAL SERVICE	Q.1–Q.3
INTERNATIONAL AUTOMATIC AND SEMI-AUTOMATIC WORKING	Q.4–Q.59
FUNCTIONS AND INFORMATION FLOWS FOR SERVICES IN THE ISDN	Q.60–Q.99
CLAUSES APPLICABLE TO ITU-T STANDARD SYSTEMS	Q.100–Q.119
SPECIFICATION OF SIGNALLING SYSTEMS No. 4 AND No. 5	Q.120–Q.249
SPECIFICATIONS OF SIGNALLING SYSTEM No. 6	Q.250–Q.309
SPECIFICATIONS OF SIGNALLING SYSTEM R1	Q.310–Q.399
SPECIFICATIONS OF SIGNALLING SYSTEM R2	Q.400–Q.499
DIGITAL EXCHANGES	Q.500–Q.599
Introduction and field of application	Q.500–Q.509
Exchange interfaces, functions and connections	Q.510–Q.539
Design objectives and measurement	Q.540–Q.549
Transmission characteristics	Q.550–Q.599
INTERWORKING OF SIGNALLING SYSTEMS	Q.600–Q.699
SPECIFICATIONS OF SIGNALLING SYSTEM No. 7	Q.700–Q.849
DIGITAL SUBSCRIBER SIGNALLING SYSTEM No. 1	Q.850–Q.999
PUBLIC LAND MOBILE NETWORK	Q.1000–Q.1099
INTERWORKING WITH SATELLITE MOBILE SYSTEMS	Q.1100–Q.1199
INTELLIGENT NETWORK	Q.1200–Q.1999
BROADBAND ISDN	Q.2000–Q.2999

For further details, please refer to ITU-T List of Recommendations.

ITU-T RECOMMENDATION Q.551

TRANSMISSION CHARACTERISTICS OF DIGITAL EXCHANGES

Summary

This Recommendation gives values for transmission characteristics related to the path from an exchange test point to an exchange interface and vice-versa. The overall characteristics for connections involving two interfaces can in most cases be obtained by suitably combining these values.

Source

ITU-T Recommendation Q.551 was revised by ITU-T Study Group 15 (1993-1996) and was approved under the WTSC Resolution No. 1 procedure on the 8th of November 1996.

FOREWORD

ITU (International Telecommunication Union) is the United Nations Specialized Agency in the field of telecommunications. The ITU Telecommunication Standardization Sector (ITU-T) is a permanent organ of the ITU. The ITU-T is responsible for studying technical, operating and tariff questions and issuing Recommendations on them with a view to standardizing telecommunications on a worldwide basis.

The World Telecommunication Standardization Conference (WTSC), which meets every four years, establishes the topics for study by the ITU-T Study Groups which, in their turn, produce Recommendations on these topics.

The approval of Recommendations by the Members of the ITU-T is covered by the procedure laid down in WTSC Resolution No. 1.

In some areas of information technology which fall within ITU-T's purview, the necessary standards are prepared on a collaborative basis with ISO and IEC.

NOTE

In this Recommendation, the expression "Administration" is used for conciseness to indicate both a telecommunication administration and a recognized operating agency.

INTELLECTUAL PROPERTY RIGHTS

The ITU draws attention to the possibility that the practice or implementation of this Recommendation may involve the use of a claimed Intellectual Property Right. The ITU takes no position concerning the evidence, validity or applicability of claimed Intellectual Property Rights, whether asserted by ITU members or others outside of the Recommendation development process.

As of the date of approval of this Recommendation, the ITU had/had not received notice of intellectual property, protected by patents, which may be required to implement this Recommendation. However, implementors are cautioned that this may not represent the latest information and are therefore strongly urged to consult the TSB patent database.

© ITU 1997

All rights reserved. No part of this publication may be reproduced or utilized in any form or by any means, electronic or mechanical, including photocopying and microfilm, without permission in writing from the ITU.

CONTENTS

	Page
1	Introduction..... 1
1.1	General..... 1
1.2	Definitions 4
1.2.1	Exchange test points, exchange input and output and half-connections 4
1.2.3	Measurement conditions..... 6
1.2.4	Transmission loss 7
1.2.6	Digital parameters..... 7
2	Characteristics of interfaces..... 8
2.1	Two-wire analogue interfaces..... 8
2.1.1	Interface Z..... 8
2.1.2	Interface C ₂ 8
2.2	Four-wire analogue interfaces..... 8
2.2.1	Interface C ₁ 8
2.3	Digital interfaces..... 9
2.3.1	Interface A 9
2.3.2	Interface B..... 9
2.3.3	V-type interfaces..... 9
3	Voice-frequency parameters of a connection between two interfaces of the same exchange 9
3.1	General..... 9
3.2	Transmission loss through the exchange 9
3.3	Group delay..... 10
3.3.1	Absolute group delay..... 10
3.3.2	Group delay distortion..... 11
3.4	Noise and total distortion..... 11
3.4.1	Weighted noise 12
3.4.2	Total distortion including quantizing distortion 14
3.5	Crosstalk 15
3.6	Discrimination against out-of-band signals applied to the input interface 16
3.7	Spurious out-of-band signals received at the output interface..... 16
3.8	Echo and stability..... 16
4	Exchange transfer function – jitter and wander 17
Annex A	– Information on the formulae used in this Recommendation to calculate weighted noise and signal-to-total distortion ratio 17

	Page	
A.1	General.....	17
A.2	Weighted noise	18
A.2.1	Weighted noise for an input connection originating from a Z-interface	18
A.2.2	Weighted noise for an output connection terminating in a Z-interface.....	19
A.2.3	Weighted noise for a whole connection originating from and terminating in a Z-interface.....	20
A.2.4	Weighted noise for an input connection originating from a 2-wire or 4-wire C-interface with or without signalling on the speech wires.....	21
A.2.5	Weighted noise for an output connection terminating at a 2-wire C-interface with $L_o \geq -5$ dBr or a 4-wire C-interface both with or without signalling on the speech wires.....	22
A.2.6	Weighted noise for an output connection terminating at a 2-wire C-interface with $L_o < -5$ dBr and with or without signalling on the speech wires.....	23
A.2.7	Weighted noise for a whole connection originating from and terminating in 2-wire or 4-wire C-interfaces with or without signalling on the speech wires	24
A.3	Total distortion including quantizing distortion	25
A.3.1	Total distortion including quantizing distortion for an input connection originating from a Z-interface.....	25
A.3.2	Total distortion including quantizing distortion for an output connection terminating in a Z-interface	26
A.3.3	Total distortion including quantizing distortion for a whole connection originating from and terminating in a Z-interface.....	27
A.3.4	Total distortion including quantizing distortion for an input connection originating from a 2-wire or a 4-wire C-interface	28
A.3.5	Total distortion including quantizing distortion for an output connection terminating in a 2-wire or a 4-wire C-interface	29
A.3.6	Total distortion including quantizing distortion for a whole connection originating from and terminating in 2-wire or 4-wire C-interfaces.....	30
Annex B	– Explanation of power, dBm, dBr, dbm0 and mW units of speech band signals in ITU	31
B.1	Introduction.....	31
B.2	The case of resistive nominal impedances, constant with frequency.....	31
B.3	The case of complex nominal impedances, varying with frequency	32

Recommendation Q.551

TRANSMISSION CHARACTERISTICS OF DIGITAL EXCHANGES

(revised in 1996)

1 Introduction

1.1 General

The field of application of this Recommendation is found in Recommendation Q.500.

A high percentage of international calls will have a digital PABX included in the connection. Therefore, Recommendations Q.551-Q.554 are applicable also for digital PABXs with regard to those specific transmission parameters affecting the transmission quality of an international call, for instance Loudness Ratings, noise, talker's and listener's sidetone, echo and stability. These Recommendations primarily concern digital PABXs connected digitally to the international network. However, Administrations may find some of the specification details useful for digital PABXs connected by analogue means to the international network.

The signals taken into consideration are passed through the following interfaces as described in Recommendations Q.511 and Q.512 and Figures 1 and 2.

- Interface A is for primary digital signals at 2048 kbit/s or 1544 kbit/s.
- Interface B is for secondary digital signals at 8448 kbit/s or 6312 kbit/s.
- Interface C comprises both 4-wire and 2-wire analogue trunk interfaces. Interfaces C₁ 4-wire and C₂ 2-wire represent possible applications of interface C in Figure 1/Q.511.

Interface C₁ represents a 4-wire and interface C₂ a 2-wire analogue trunk interface. For practical reasons, C₁ and C₂ are further subdivided into C₁₁, C₁₂, C₁₃, C₂₁ and C₂₂.

C₁₁ interfaces channel translating equipment. C₁₂ and C₁₃ interface 4-wire analogue exchanges; C₁₂ via the relay sets, C₁₃ directly to the switching stages.

C₂₁ is an interface applicable when a 2-wire circuit connects a digital transit exchange with a local exchange, analogue or digital. C₂₂ is an interface applicable when a 2-wire circuit connects local exchanges, analogue and/or digital.

See Figures 1 and 2 for illustration of the principles.

- Interface type V is for digital subscriber line access.
- Interface type Z is for analogue subscriber line access.

It should be noted that the ITU-T only recommends the C interfaces with certain reservations. The most important disadvantages, namely the reduction in flexibility and multiplicity, are mentioned in 4.1/Q.511.

NOTE 1 – Remote analogue exchange concentrators and analogue PABXs may use interface Z for access to a digital exchange.

NOTE 2 – In the future, differences in circuit configurations with respect to transmission parameters may cause a subdivision of the Z interface.

Also for interfaces other than those designated Z, there can exist types whose transmission characteristics have not been defined, even though they may be recognized as being in practical operation. This may be due to ITU-T not having considered their international standardization justified, e.g. because of their limited use, or because their function is to coordinate with pre-existing national standards. However, later additions to recommended interfaces are not ruled out (e.g. 4-wire

subscriber interface).

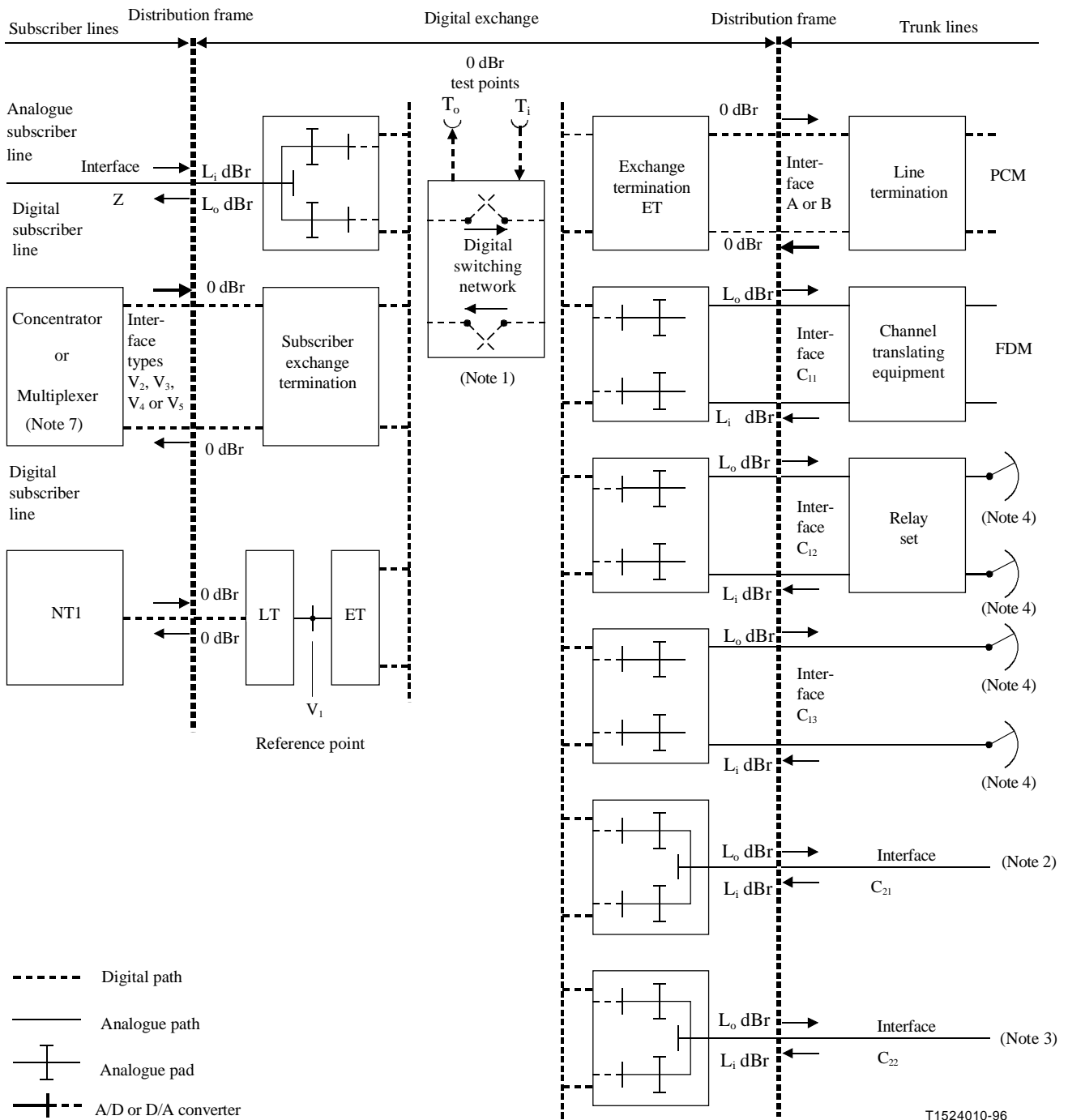

- NOTE 1 – Digital loss pads, if required, may be located in the switching network or the exchange terminals (see 1.2.4.1).
 NOTE 2 – Termination of international long-distance switched connections (see Figure 2).
 NOTE 3 – Termination of local 2-wire trunk switched traffic (see Figure 2).
 NOTE 4 – Virtual international connecting point (see Recommendation G.101).
 NOTE 5 – This figure shows typical examples utilizing the defined interfaces.
 NOTE 6 – For different interfaces, the values of L_i and L_o are, in general, not equal.
 NOTE 7 – For details, refer to Figure 1/Q.512 and Figure 2/G.960.

Figure 1/Q.551 – Interfaces, transmission levels and test points at a digital exchange

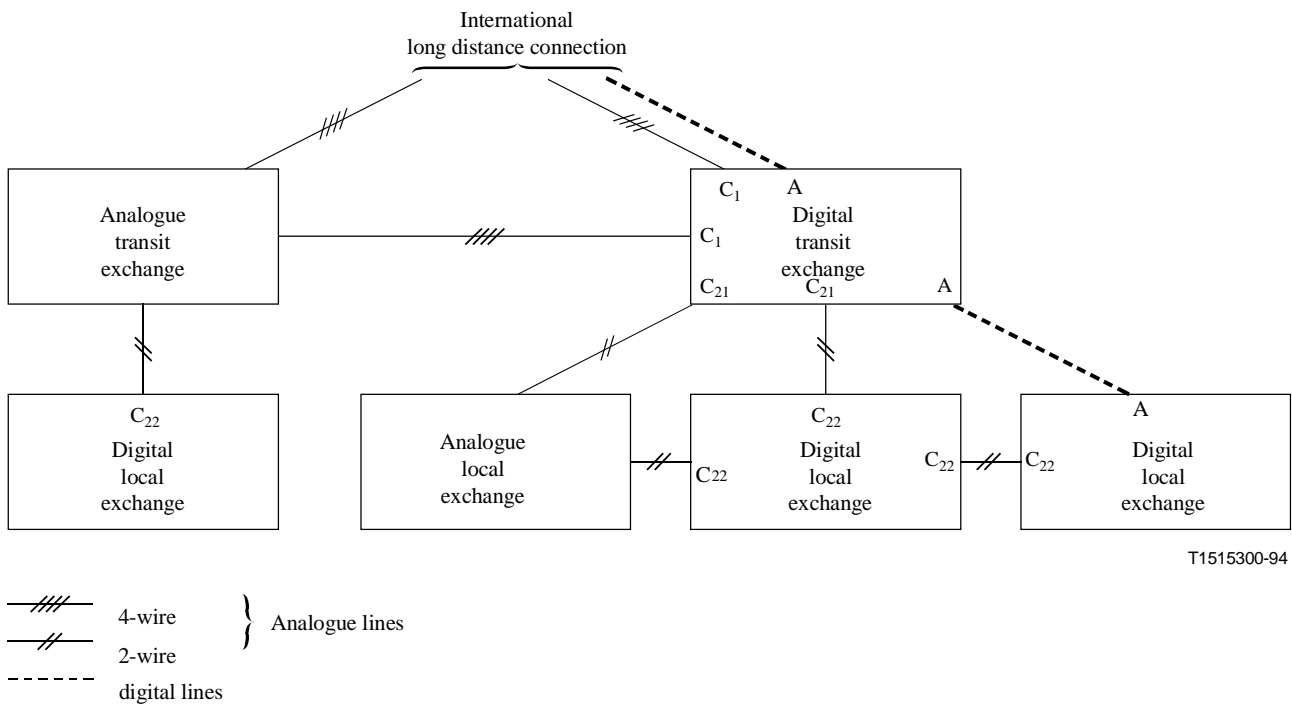

NOTE – The trunks between local exchanges carry local traffic only.

Figure 2/Q.551 – Interfaces in possible network interconnections

Interface types V and Z may appear remote from the exchange through the use of digital transmission facilities. When this occurs, there should be no impact on transmission parameters other than delay. Transmission parameters associated with interface Z include the effects of the equipment provided for interfacing the analogue subscriber line to the digital switching network of the exchange.

It is necessary to ensure that representative DC currents are flowing during the measurements of all of these transmission parameters. These DC currents can contribute to noise, distortion, crosstalk, variation of gain with input level, etc. Therefore, appropriate allowances for this must be made. In some cases, where indicated, the permissible limits quoted include these allowances.

Detailed transmission characteristics for these interfaces are provided in the following Recommendations:

- Recommendation Q.552 for 2-wire analogue interfaces;
- Recommendation Q.553 for 4-wire analogue interfaces;
- Recommendation Q.554 for digital interfaces.

In the present Recommendations, values given for transmission characteristics relate to the path from an exchange test point to an exchange interface and vice versa; the overall characteristics for connections involving two interfaces can, in most cases, be obtained by suitably combining these values (see clause 3).

In the future, other interfaces may be defined.

These Recommendations consider analogue signals which are encoded in accordance with Recommendation G.711.

The transmission characteristics of voice-frequency (VF) connections through a digital transit exchange should in principle provide performance in accordance with Recommendation G.712 and, where applicable, Recommendation Q.45 *bis* (see also Recommendation G.142).

The principles of Recommendation G.142 and the limits of Recommendation G.712 have been used as a basis for establishing the transmission characteristics for analogue voice-frequency connections specified in clauses 2/Q.552 and 3/Q.553. The limit values are not necessarily identical with those specified in the G-Series, since in the case of a connection through the exchange, additional allowances generally have been made for cabling (see clause 2).

The values given are to be considered as either "design" or "performance objectives" according to the explanations of the terms given in Recommendation G.102 (Transmission performance and objectives and recommendations) and the particular context.

The specification clauses in this Recommendation exclude the effects of auxiliary functions such as echo suppression, echo cancellation or transmission to the subscriber of metering impulses, or of non-telephony functions such as telemetering over the subscriber pair.

1.2 Definitions

1.2.1 Exchange test points, exchange input and output and half-connections

1.2.1.1 exchange test points: The exchange test points shown in Figure 1 are defined for specification purposes. They generally do not physically exist in an exchange but are accessed via the digital switching network. In this case, some or all of the switching network will be included in the path from the exchange interface to the access points.

The transmission parameters affected by this means of access are the absolute group delay and possibly jitter and wander and bit error ratio. For most other parameters, either the exchange test points or the access points are located such that end-to-end performance can be determined by suitably combining performances between each interface and either the exchange test points or the access points.

1.2.1.2 exchange input and output: The exchange input and output for a connection through a digital exchange are located at the interfaces identified in 1.1 and shown in Figures 1 and 2.

The exact position of each of these points depends on national practice, and it is not necessary for the ITU-T to define it.

However, the applicability of recommended values to points arbitrarily located is subject to certain restrictions:

- for analogue interfaces, as referred to in clause 2 (maximum length of exchange cabling between exchange equipment ports and the interface);

The term equipment port in this Recommendation is defined as a functional unit (e.g. connector) of the equipment through which signals can enter or leave the unit under test. Requirements for measurements made at an equipment port do not include an allowance for wiring to a distribution frame.

- for digital interfaces, as also mentioned in clause 2 (maximum loss between exchange interfaces and connected equipment, e.g. digital line or higher order multiplex equipment).

NOTE – Transmission planning of the network is based on the characteristics presented to each other by the exchange and transport networks across the interfaces constituting the boundaries of responsibility between these respective functions – see Figure 1/Q.511. Whereas these points are accessible for a network in overall operation, they will not exist for acceptance testing of exchange equipment before installation, which must therefore use the equipment ports. While in many cases the difference caused by exchange cabling may be negligible, this is not always the case. The choice of exchange cabling and the possible need for compensating its effects should therefore be born in mind.

1.2.1.3 Half-connections

1.2.1.3.1 input connection: A unidirectional path from an interface of a digital exchange to an exchange test point.

1.2.1.3.2 output connection: A unidirectional path from an exchange test point to an interface of a digital exchange.

1.2.1.3.3 half-connection: A bidirectional path comprised of an input connection and an output connection, both having the same exchange interface.

NOTE 1 – These terms may be qualified by the words "analogue" or "digital", the qualification signifying the property of the exchange interface.

NOTE 2 – An analogue input (output) (half) connection may be further qualified by the words "2-wire" or "4-wire".

1.2.2 relative levels: The relative level designations in the Q.550-Series Recommendation refer to the power handling capacity of the half-connections. When the half-connections are considered as elements of a circuit in a transmission plan, the associated relative level designations may be given other values. See Annex A/G.100, and Recommendation G.101.

1.2.2.1 Exchange test points

The nominal relative level at the input and output exchange test points is assigned the value 0 dBr.

1.2.2.2 Analogue interfaces

The nominal relative level at the exchange input point is designated L_i .

The nominal relative level at the exchange output point is designated L_o .

1.2.2.3 Digital interfaces

The relative level to be associated with a point in a digital path carrying a digital bit stream generated by a coder lined-up in accordance with the principles of Recommendation G.101 is determined by the value of the digital loss or gain between the output of the coder and the point considered.

If there is no such loss or gain, the relative levels at the exchange input and output points (i.e. digital interfaces V, A and B) are by convention said to be 0 dBr. For further information, see 5.3.2.4/G.101.

NOTE – The digital level may be established using measuring equipment in accordance with Recommendation O.133.

Relative level has no meaning for digital bit streams that are not derived from real or simulated analogue sources.

1.2.3 Measurement conditions

1.2.3.1 Common measurement conditions

All digital signal processing devices which affect bit integrity of the 64 kbit/s path (e.g. digital loss pads, code converters, digital echo control devices, digital speech interpolation apparatus or all-zero-suppressors) must be rendered inoperative when measuring the transmission parameters of this Recommendation. However, if the nominal transmission loss, NL, for speech connections is implemented by a digital loss pad, the loss pad must not be inoperative when measuring parameters dependent on NL.

Where measuring transmission parameters between 2-wire ports is considered necessary, the opposite direction of transmission must be interrupted in order to avoid disturbing effects due to reflections at hybrids.

In addition, a quiet code, i.e. a PCM signal corresponding to decoder output value 0 (μ -law) or output value 1 (A-law), with the sign bit in a fixed state should be applied to the exchange test point.

NOTE – These patterns are slightly different from the idle code produced by an exchange (see e.g. 2.12/Q.522).

1.2.3.2 Reference frequency

For the reference frequency, Recommendation O.6 applies:

- A reference test frequency of 1020 Hz is recommended for test frequency generating circuits or instruments that provide reference test frequencies. The specified frequency tolerance should be +2 to –7 Hz.

1.2.3.3 Impedance

Unless otherwise specified, measurements at analogue interfaces shall be made under nominally matched conditions.

NOTE – The preferred interpretation of this statement should be that the nominal exchange impedance should be used as the internal impedance of the analogue test generator and the analogue level meter. However, under some circumstances it may be preferable to use a low impedance generator and a high impedance meter. Such a configuration avoids measurement errors which would otherwise result from impedance mismatch (e.g. due to component tolerances).

1.2.3.4 Test levels at analogue interfaces

At the reference frequency, test levels are defined in terms of the apparent power relative to 1 mW.

Where no value is given, the test level should be –10 dBm₀. When a test level of 0 dBm₀ is used (e.g. 3.1.4/Q.552), care should be taken to disconnect, or otherwise protect, connected facilities from excessive loading.

At frequencies different from the reference frequency, test levels are defined as having the same voltage as the test level at the reference frequency. Measurements are based on the use of a test generator with a frequency-independent EMF.

The above considerations are primarily concerned with measurements at discrete frequencies. Psophometric measurements of composite signals at interfaces with complex impedances should be performed with a psophometer having an input impedance equal to the nominal complex impedance specified for that interface. (The psophometer must be calibrated accordingly. See also Recommendation O.41 and Annex A/G.100.)

1.2.4 Transmission loss

1.2.4.1 Nominal transmission loss: A connection through the exchange (see Figure 1) is established by connecting in both directions an input located at one interface to an output located at another interface.

The nominal transmission loss between the input at an analogue interface and the exchange test point is defined as:

$$NL_i = L_i$$

The nominal transmission loss between the exchange test point and the output of an analogue interface is defined as:

$$NL_o = -L_o$$

The nominal transmission loss for a connection through an exchange is equal to the difference of the relative levels at the input and the output.

$$NL = (L_i - L_o) + x \text{ dB}$$

where x is the value of any loss implemented in the switching network.

This is equal to the nominal "composite loss" (see definition in *Blue Book*, Fascicle I.3) at the reference frequency. See also 2.1/G.101 and Supplement No. 1 in Fascicle VI.5 of the CCITT *Blue Book*.

NOTE 1 – The nominal transmission loss, NL, may be implemented by an analogue loss pad. It may also be implemented by a digital loss pad. In the latter case, the digital loss pad may be on the incoming side of the digital switching network, or on the outgoing side of the digital switching network or both.

As a general principle, the use of digital loss pads should be avoided because bit integrity is lost for digital services and additional transmission impairments are introduced for analogue services.

However, it is recognized that during the transition stage to a completely digital network, existing national transmission plans may require digital pads to be inserted for speech.

In addition, connections in a future ISDN used for voice can be expected to contain other devices which destroy bit integrity of the 64 kbit/s path (e.g. code converters, digital echo control devices, digital speech interpolation apparatus, or all-zero-suppressors). Provision must be made to render all such devices inoperative when necessary. See 3.1.3/Q.554

NOTE 2 – The nominal transmission loss of the exchange may be different in the two directions.

1.2.5 Attenuation frequency distortion: The attenuation frequency distortion (loss distortion) is the logarithmic ratio of output voltage at the reference frequency (nominally 1020 Hz), $U(1020 \text{ Hz})$, divided by its value at frequency f , $U(f)$:

$$LD = 20 \log \frac{U(1020 \text{ Hz})}{U(f)}$$

See Supplement No. 1 in Fascicle VI.5 of the CCITT *Blue Book*.

1.2.6 Digital parameters

1.2.6.1 bit integrity: The property of a digital half-connection of a digital exchange in which the binary values and the sequence of the bits in an octet at the input of the half-connection are reproduced exactly at the output.

NOTE – Digital processing devices such as A/ μ -law converters, echo suppressors and digital pads must be disabled to provide bit integrity.

2 Characteristics of interfaces

The interfaces taken into account are those of Figures 1/Q.511 and 1 of this Recommendation. For voice-frequency interfaces (C and Z), the electrical parameters refer to the appropriate distribution frame (DF), on the assumption that the length of the cabling between the DF and the actual exchange does not exceed 100 m (exchange cables). In this respect, clause 3/Q.45 *bis*, applies. For corresponding limitations on the location of digital interfaces, see Recommendation G.703.

Principles of determining an impedance strategy for the local network (e.g. exchange impedance, balance impedance) can be found in Appendix I/Q.552.

2.1 Two-wire analogue interfaces

Detailed transmission characteristics of 2-wire analogue interfaces are provided in Recommendation Q.552.

2.1.1 Interface Z

The interface Z provides for the connection of analogue subscriber lines and will carry signals such as speech, voiceband analogue data and multi-frequency push button signals, etc. In addition, the interface Z must provide for DC feeding for the subscriber set and ordinary functions such as DC signalling, ringing, metering, etc., where appropriate.

Other auxiliary functions, as mentioned in 1.1 above, are not considered as forming part of the exchange but rather of the line, i.e. not included on the exchange side. Since the interface Z ordinarily terminates the subscriber line, it is necessary to control the impedance and unbalance about earth. (While this will also be true of equipment providing auxiliary functions, its specification is not dealt with here.)

When the Z interface is used as an extension line interface of a digitally connected digital PABX, additional functions may be required to provide special features of the PABX. If the extension line is entirely contained within a building, some attributes of the PABX such as longitudinal conversion loss, may no longer need to be specified and others may take special values.

2.1.2 Interface C₂

The interface C₂ provides for the connection of 2-wire analogue circuits to other exchanges.

The interface C₂₁ provides the termination of outgoing and incoming international long-distance connections and possibly national connections also with the exchange acting as a transit switch (see Figure 2).

The interface C₂₂ provides for the connection of a 2-wire trunk line. Typical is the interconnection of a Z interface with a C₂₂ interface in a local exchange for routings through the existing 2-wire analogue trunk network. A C₂₂ interface cannot be part of the international 4-wire chain.

2.2 Four-wire analogue interfaces

Detailed transmission characteristics of 4-wire analogue interfaces are provided in Recommendation Q.553.

2.2.1 Interface C₁

The interface C₁ provides for the connection of 4-wire analogue circuits to other exchanges.

According to Figure 1, the interface C₁₁ of a digital exchange is intended for connection to the channel translating equipment of an FDM system.

According to Figure 1, the interface C_{12} of a digital exchange is intended for connection to the incoming and outgoing relay set of an analogue 4-wire exchange (see Figure 1/Q.45 *bis*).

According to Figure 1, the interface C_{13} of a digital exchange is intended for connection to a 4-wire analogue switching stage (see Figure 1/G.142, case 5.)

2.3 Digital interfaces

Detailed transmission characteristics of digital interfaces are provided in Recommendation Q.554.

2.3.1 Interface A

The interface A operating at a rate of 1544 kbit/s or 2048 kbit/s provides for the digital connection of circuits to other exchanges.

2.3.2 Interface B

The interface B operating at a rate of 6312 kbit/s or 8448 kbit/s provides for the digital connection of circuits to other exchanges.

2.3.3 V-type interfaces

V-type interfaces provide for digital subscriber line access.

V-type interfaces allow the connection to the exchange of a digital subscriber line capable of providing digital subscriber side access for ISDN. The different variants, V_2 , V_3 etc., are described in clause 3/Q.512. It will be seen that the differences lie essentially in multiplexing and in the associated signalling facilities, the transmission requirements being substantially identical, i.e. providing 64 kbit/s B-channels, with bit integrity assumed unless the transmission plan specifically requires otherwise. See also 2.5/Q.554.

NOTE – The designation "V₁" is applied to a reference point which is connected to a basic access digital section.

3 Voice-frequency parameters of a connection between two interfaces of the same exchange

3.1 General

This clause provides guidance on obtaining the overall characteristics for connections between two interfaces of the same exchange. For overall connections involving one or more digital interfaces, the results may be interpreted by assuming that ideal send and receive sides (see Recommendation G.712) are connected to the digital inputs and outputs, respectively.

In this clause, transmission parameters relating to the path from an exchange interface to an exchange test point will be referred to as input parameters. Transmission parameters relating to the path from an exchange test point to an exchange interface will be referred to as output parameters.

3.2 Transmission loss through the exchange

The transmission loss through the exchange is equal to the algebraic sum of the input transmission loss and the output transmission loss.

The overall characteristic for the following parameters can be obtained the same way:

- short-term variation of loss with time;
- attenuation/frequency distortion;
- variation of gain with input level.

3.3 Group delay

"Group delay" is defined in the *Blue Book*, Fascicle I.3.

3.3.1 Absolute group delay

"Absolute group delay" refers to the minimum group delay measured in the frequency band 500 – 2800 Hz.

The absolute group delay through an exchange will very much depend on the exchange architecture and the types of connections involved. Table 1 gives estimated mean and 0.95 probability of not exceeding values of round trip delay between interfaces exemplified in Figure 3. These values may not be applicable to digital PABXs.

The absolute group delay includes delay due to electronic devices such as frame aligners and time stages of the switching matrix but does not include delays due to ancillary functions, such as echo suppression or echo cancellation.

Table 1/Q.551 – Round trip delay between interfaces as depicted in Figure 3

Reference (Figure 3)	Mean (µs)	0.95 probability of not exceeding (µs)
a)	900	1500
b)	1950	2700
c)	1650	2500
d)	3000	3900
e)	2700	3700
f)	2400	3500

NOTE 1 – These values for the absolute group delays are applicable under reference load A conditions as defined in Recommendation Q.543.

NOTE 2 – These values do not include the propagation delay associated with transmission across the link between the main part and any remotely located parts of a digital local exchange.

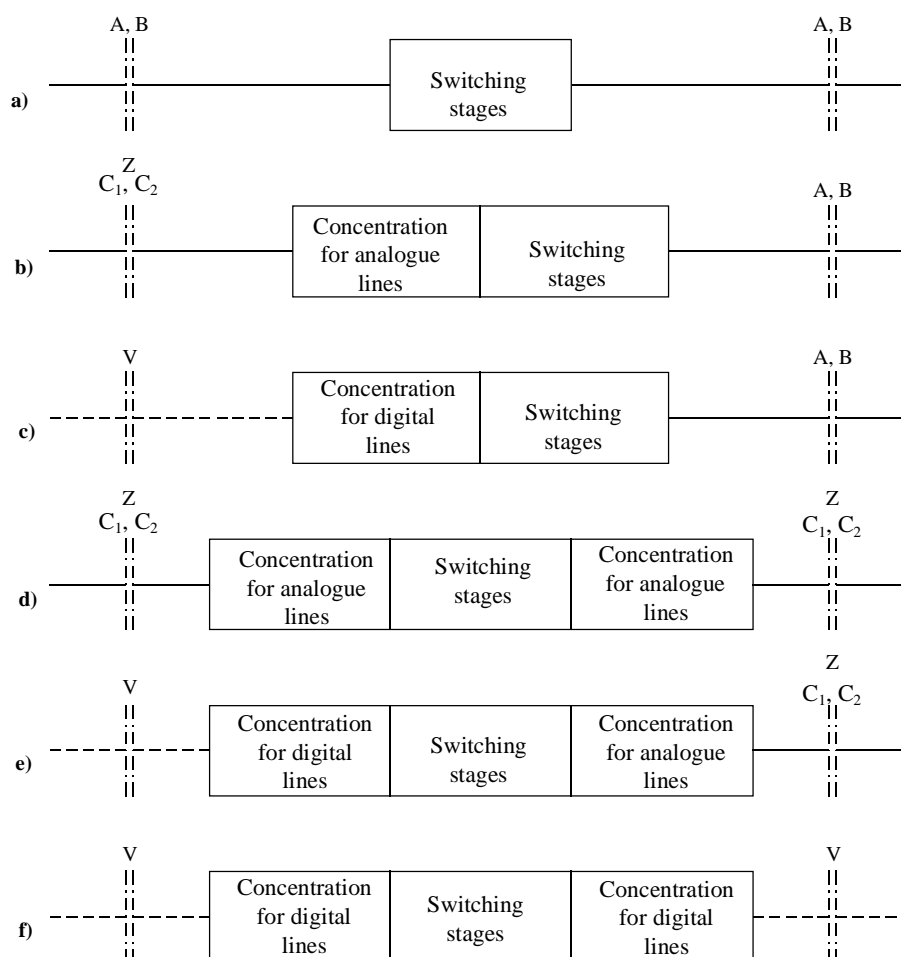

T1515310-94

Figure 3/Q.551 – Exchange configurations as used for estimation of round trip absolute group delay

3.3.2 Group delay distortion

The total group delay distortion is equal to the sum of the input and the output group delay distortions.

3.4 Noise and total distortion

When evaluating the exchange noise characteristics, it is necessary to consider two components of noise. One of these arises from the PCM translating process, the other from analogue sources e.g. signalling circuits, exchange power supply, line power feeding on both sides of a connection between two interfaces through the same exchange.

The noise arising from the PCM translating process is limited by Recommendation G.712, the noise from analogue sources by Recommendation G.123. This applies to both weighted noise and total distortion. The requirements for weighted noise and total distortion for connections between the same interfaces and through the same exchange are of value for test purposes.

In real connections through the network, usually several connections between different exchanges with different levels and different interfaces apply. This would result in very complex calculations for the overall noise contribution and cannot be handled in a simple way. Consideration of the contribution of noise and total distortion for each individual half-connection as specified in Recommendations Q.552 and Q.553 for the case in question should be preferred.

Figure 4 represents six different test configurations, namely:

- three configurations for C-interfaces with P_{AN} given in pW0p;
- the same three configurations for Z-interfaces but with P_{AN} given in pWp.

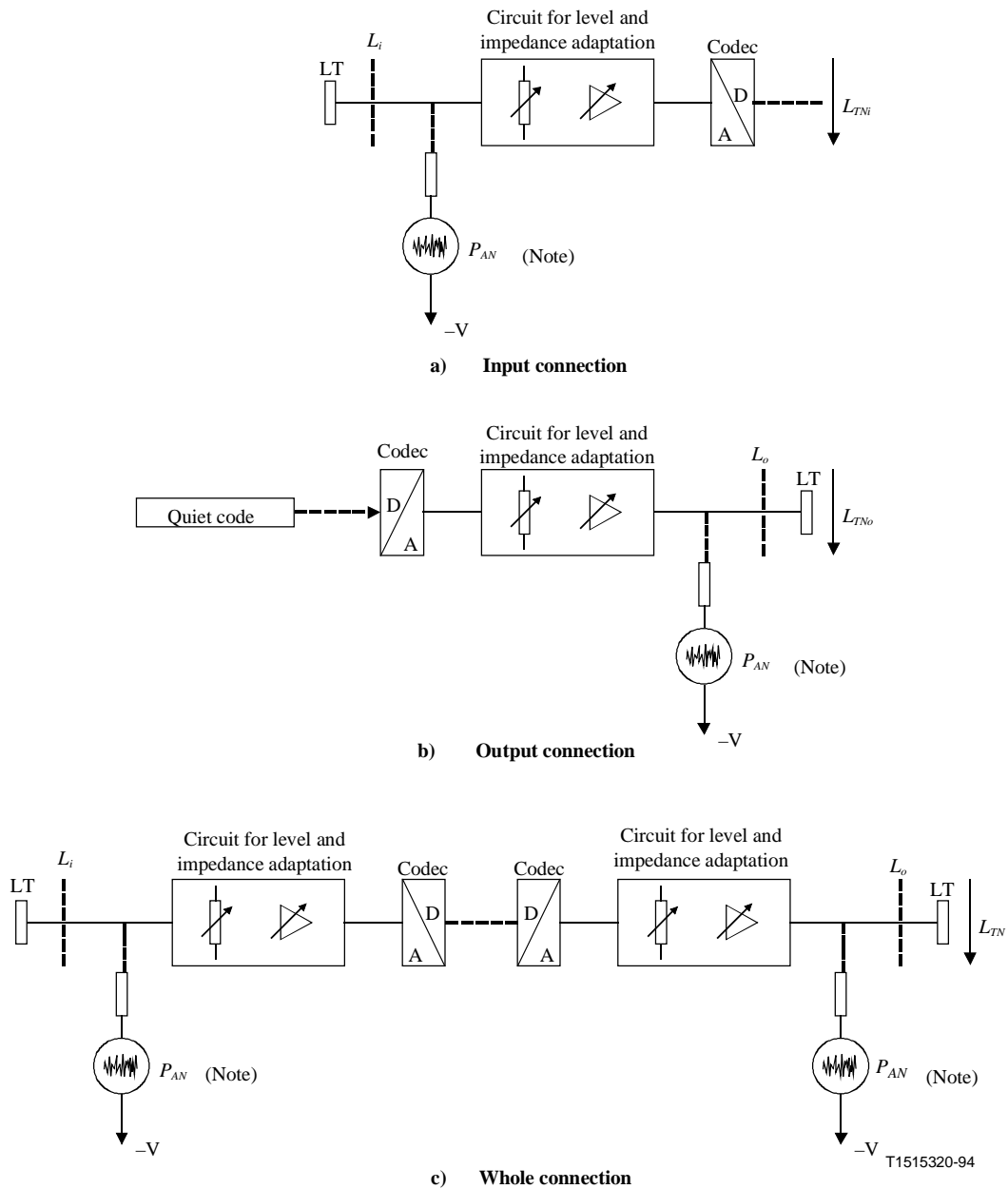

NOTE – P_{AN} to be considered for Z-interface with feeding and C-interfaces with signalling on the speech wires. LT = Line termination with matched conditions. All other abbreviations are in line with the text of this Recommendation.

Figure 4/Q.551

3.4.1 Weighted noise

The total psophometric noise power is approximated by the following formulae: (see Annex A for more information on how these formulae can be derived).

- For an input connection originating at a Z-interface:

$$P_{TN} = P_{AN} \times 10^{\frac{L_i}{10}} + 10^{\frac{90+L_{IN}}{10}} \quad [\text{pW0p}] \quad (3-1)$$

- For an output connection terminating at a Z-interface:

$$P_{TN} = P_{AN} + 10^{\frac{90+L_{IN}+L_o}{10}} \quad [\text{pWp}] \quad (3-2)$$

- For a whole connection originating and terminating at a Z-interface:

See Annex A.

- For an input or an output connection originating and terminating at 4-wire C-interfaces, for an input connection originating at a 2-wire C-interface, for an output connection terminating at a 2-wire C-interface with $L_o \geq -5$ dBr, in all three cases with or without ($P_{AN} = 0$) signalling on the speech wires:

$$P_{TN} = P_{AN} + 10^{\frac{90+L_{IN}}{10}} \quad [\text{pW0p}] \quad (3-3)$$

- For an output connection terminating at a 2-wire C-interface with $L_o < -5$ dBr and with or without ($P_{AN} = 0$) signalling on the speech wires:

$$P_{TN} = P_{AN} + 10^{\frac{90+L_{IN}-L_o}{10}} \quad [\text{pW0p}] \quad (3-4)$$

- For a whole connection originating and terminating at 2-wire or 4-wire C-interfaces:
See Annex A.

This results in a total noise level of:

$$L_{TN} = 10 \times \log\left(\frac{P_{TN}}{1\text{PW}}\right) - 90 \begin{cases} [\text{dBmp}] & \text{if } P_{TN} \text{ in pWp} \\ [\text{dBm0p}] & \text{if } P_{TN} \text{ in pW0p} \end{cases}$$

where:

P_{TN} is the total weighted noise power in pWp at Z-interfaces or in pW0p at C-interfaces of a whole connection through the digital exchange or of an input or output connection.

P_{AN} is the weighted noise power caused by analogue functions according to Annex A/G.123, for:

- Z-interfaces, i.e. 200 pWp (including noise generated by the circuit for level and impedance adaptation);
- C-interfaces with signalling on the speech wires, i.e. 100 pW0p (including noise generated by the circuit for level and impedance adaptation);
NOTE – A value of 200 pW0p is defined in Recommendation G.123 for a whole connection. This noise power is split-up equally to the input and output connections resulting in a noise power of 100 pW0p.
- C-interfaces without signalling on the speech wires 0 pW0p (see Recommendation G.712).

L_o output relative level in dBr.

L_i input relative level in dBr.

L_{IN} weighted noise (idle channel noise) for PCM translating equipment for:

- whole 2-wire or 4-wire connections according to Recommendation G.712, i.e. –65 dBm0p (–64 dBm0p for relative output levels < –5 dBr for 2-wire interfaces without signalling on the speech wires);
- input connections according to Recommendation G.712, i.e. –67 dBm0p;
- output connections according to Recommendation G.712, i.e. –70 dBm0p (–75 dBm0p or 31.6 pWp for relative output levels < –5 dBr for 2-wire interfaces without signalling on the speech wires).

L_{TN} total weighted noise level of a whole connection through the digital exchange or at the analogue interface of an input or output connection in dBm0p or dBm0p.

For combinations of Z- and C-interfaces or different types of C-interfaces, similar considerations can be made to obtain the allowed psophometric noise power.

NOTE – The formulae above apply to digital exchanges but can also be used for calculating noise for PCM transmission systems according to Recommendation G.712.

3.4.2 Total distortion including quantizing distortion

The method shown below uses the sinusoidal test signal with the reference frequency of 1020 Hz as specified in Recommendation O.132. The ratio of signal-to-total distortion power for a whole connection through the exchange or a half-connection is given by the formulae (see Annex A for more information on how these formulae can be derived):

- For an input connection originating at a Z-interface:

$$\frac{S}{N_T} = L_s - 10 \times \log \left(10^{\frac{L_s - S/N}{10}} + 10^{\frac{L_{Ni} - L_i}{10}} \right) [\text{dB}] \quad (3-5)$$

- For an output connection terminating at a Z-interface:

$$\frac{S}{N_T} = L_s - 10 \times \log \left(10^{\frac{L_s - S/N}{10}} + 10^{\frac{L_{No} - L_o}{10}} \right) [\text{dB}] \quad (3-6)$$

- For whole connections originating and terminating at a Z-interface:

See Annex A.

- For an input connection originating at 2-wire or 4-wire C-interfaces:

$$\frac{S}{N_T} = L_s - 10 \times \log \left(10^{\frac{L_s - S/N}{10}} + 10^{\frac{L_{Ni}}{10}} \right) [\text{dB}] \quad (3-7)$$

- For an output connection terminating at 2-wire or 4-wire C-interfaces:

$$\frac{S}{N_T} = L_s - 10 \times \log \left(10^{\frac{L_s - S/N}{10}} + 10^{\frac{L_{No}}{10}} \right) [\text{dB}] \quad (3-8)$$

- For a whole connection originating or terminating at 2-wire or 4-wire C-interfaces:

See Annex A.

where:

S/N_T is the resulting signal-to-total distortion ratio in dB for a whole connection through a digital exchange or a half-connection.

L_s signal level of the measuring signal in dBm0, measured at the output of the connection.

L_o, L_i output and input relative level of the exchange in dBr.

S/N signal-to-total distortion ratio in dB for the PCM translating equipment alone for:

- a whole connection according to Figure 11/G.712;
- an input or output connection according to Figure 12/Q.552.

L_{No}, L_{Ni} is the weighted noise caused by analogue functions according to Annex A/G.123 (including noise generated by the circuit for level and impedance adaptation), for:

- Z-interfaces, i.e. -67 dBmp;
- a C-interface with signalling on the speech wires i.e.:

$$-(67 + 3) \text{ dBm0p} = -70 \text{ dBm0p};$$

NOTE – A value of -67 dBm0p is defined in Recommendation G.123 for a whole connection. This noise power is split up equally to the input and output connections resulting in a noise power of $-(67 + 3)$ dBm0p = -70 dBm0p.

- a C-interface without signalling on the speech wires; the terms $10^{L_{No}/10}$ and $10^{L_{Ni}/10}$ become zero.

For combinations of Z- and C-interfaces or different types of C-interfaces, similar considerations can be made to obtain the allowed total distortion.

NOTE – The formulae above apply to digital exchanges but can also be used for calculating signal-to-total distortion ratio for PCM transmission systems according to Recommendation G.712.

3.5 Crosstalk

Where measurement of the signal-to-crosstalk ratio between any two complete connections (analogue to analogue) through the exchange is considered necessary, a sine wave test signal at the reference frequency of 1020 Hz and at a level of 0 dBm0 is applied to the analogue 2-wire or 4-wire interface of one connection. An auxiliary low level activating signal, for example a sine wave at a level in the range -33 to -40 dBm0, is injected into the input of the connection to be measured. The level produced in any other connection should not exceed -65 dBm0 (value to be further studied).

Care must be taken on the choice of frequency and the filtering characteristics of the selective measuring equipment, in order to avoid that the activating signal and noise affects the accuracy of the crosstalk measurement. This measurement arrangement is shown in Figure 5.

NOTE 1 – The go-to-return crosstalk of 4-wire connections is covered by 3.1.4.1.2/Q.553 and 3.1.4.2.2/Q.553.

NOTE 2 – Measurement of NEXT is not required, as it is the same as in a half-connection.

NOTE 3 – If it is not possible without considerable difficulty to break the return path of the 4-wire loop, reflection should be minimized by making the terminating impedance and the balance impedance equal.

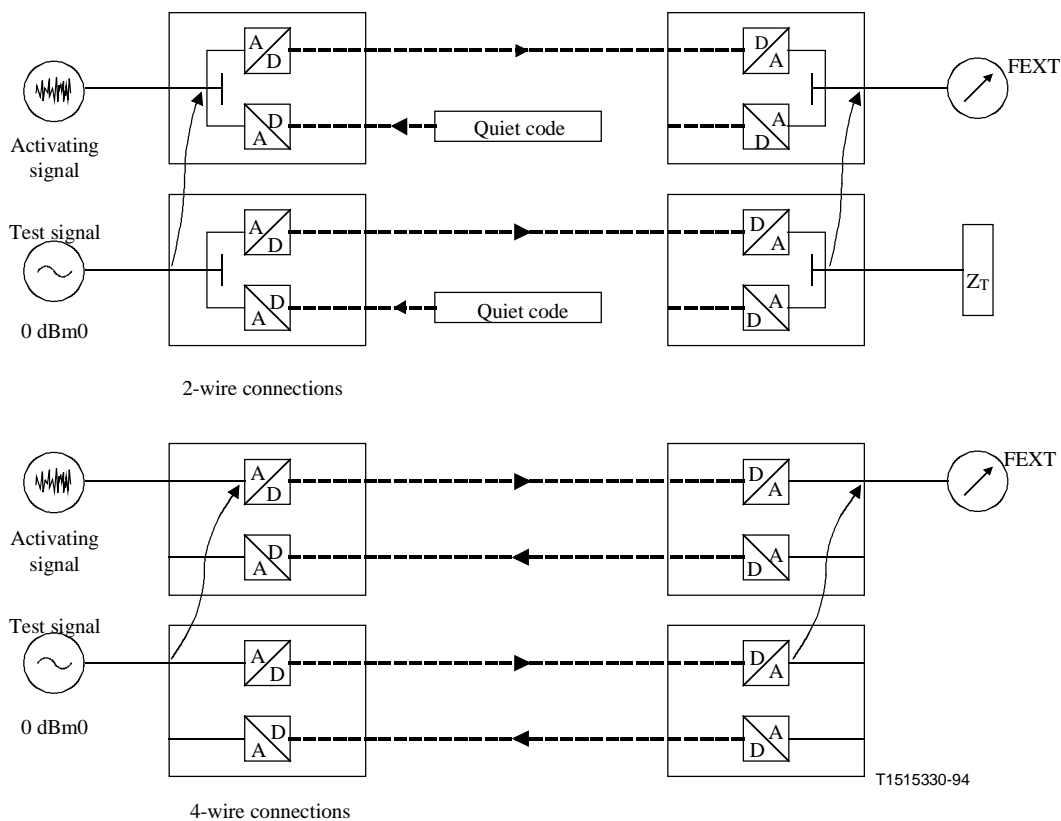

Figure 5/Q.551 – Measurement of crosstalk between two connections

3.6 Discrimination against out-of-band signals applied to the input interface

The values for these parameters for a complete connection through an exchange are identical to the corresponding values for a half-connection. See 3.1.6/Q.552 and 3.1.6/Q.553.

3.7 Spurious out-of-band signals received at the output interface

The values for these parameters for a complete connection through an exchange are identical to the corresponding values for a half-connection. See 3.1.7/Q.552, and 3.1.7/Q.553.

3.8 Echo and stability

When a complete connection, comprised of a 2-wire analogue half-connection and a 4-wire half-connection, terminates the international chain, the total stability loss of the national extension is provided by the 2-wire analogue half-connection. See 3.1.8/Q.552.

If, in a digital exchange (including PABXs), 2-wire half-connections (Z- or C₂-interfaces) cooperate in such a way that an additional 2-wire-4-wire-2-wire conversion is included as part of an international connection, then Recommendation G.122, concerning echo and stability, and, especially, Recommendation G.126, concerning effects of listener echo, has to be fulfilled.

The effects of listener echo depend on the maximum total number of loops in a complete connection. Listener echo signals:

- can lead to objectionable "hollowness" in voice communications; and
- can impair the bit error ratio of received voiceband data signals.

4 Exchange transfer function – jitter and wander

The exchange transfer function relates wander at the output of the exchange to wander at the inputs used for synchronization purposes. It is recognized that the approach of using the exchange transfer function to specify the performance of an exchange is not applicable to all implementations (e.g. when mutual synchronization methods are used). The exchange transfer mask is similar to that of a low pass filter with a maximum gain of 0.2 dB, a break point at 0.1 Hz and slope of 6 dB/octave as shown in Figure 6.

The higher frequency (jitter) portion of the mask is undefined, but must provide significant attenuation above 100 Hz.

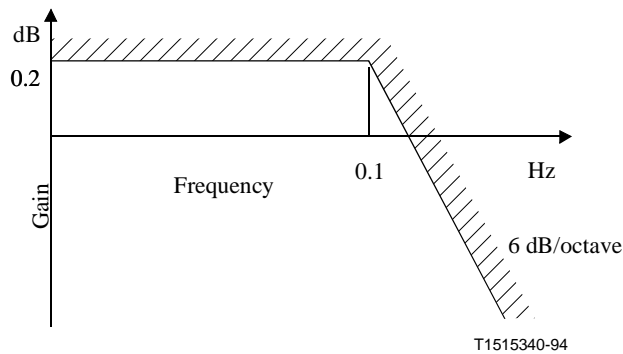

Figure 6/Q.551 – Exchange transfer function mask

ANNEX A

Information on the formulae used in this Recommendation to calculate weighted noise and signal-to-total distortion ratio

A.1 General

This annex contains background information on how the formulae used in this Recommendation to calculate weighted noise and signal-to-total distortion ratio are derived.

In addition, formulae applicable to whole connections are given.

A.2 Weighted noise

A.2.1 Weighted noise for an input connection originating from a Z-interface

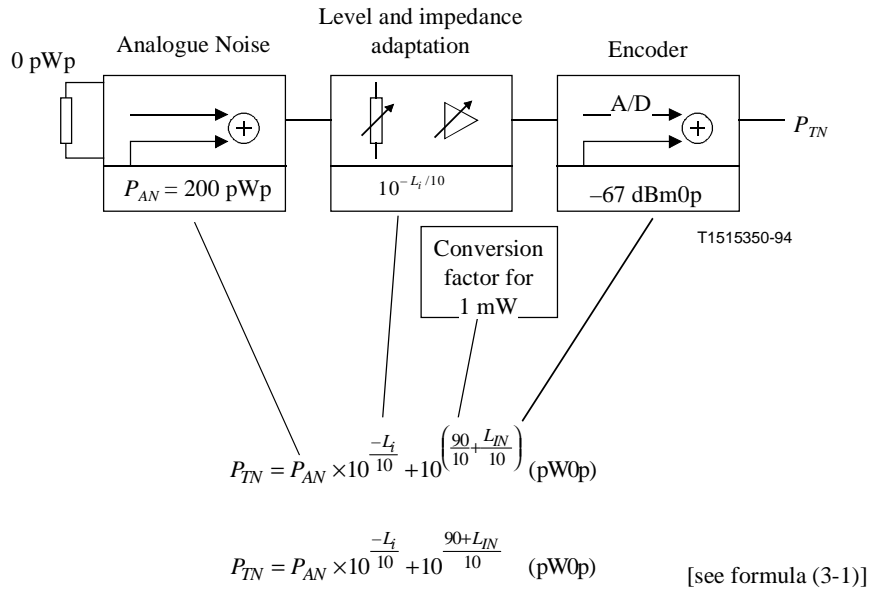

where:

P_{TN} is the total weighted noise power in pW0p at Z-interfaces of an input connection.

P_{AN} is the weighted noise power caused by analogue functions according to Annex A/G.123 for Z-interfaces, i.e. 200 pWp (including noise generated by the circuit for level and impedance adaptation).

L_i is the input relative level in dB.

L_{IN} is the weighted noise (idle channel noise) for PCM translating equipment for input connections according to Recommendation G.712, i.e. -67 dBm0p.

A.2.2 Weighted noise for an output connection terminating in a Z-interface

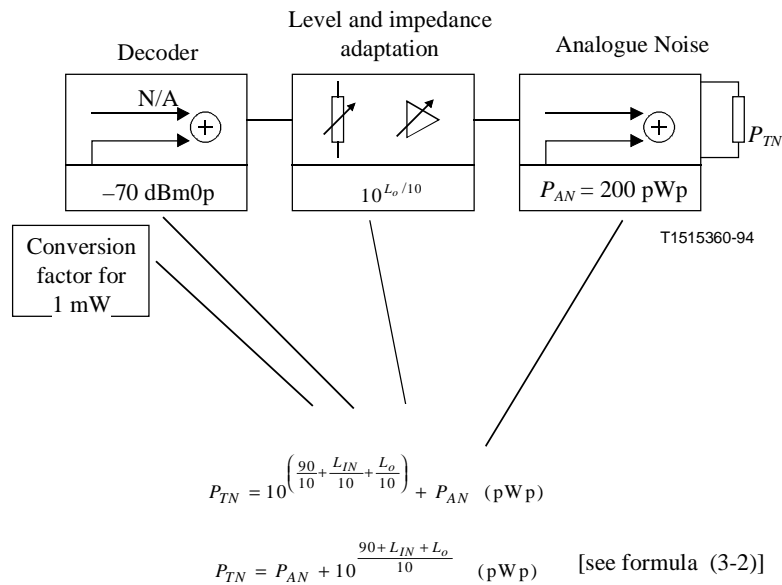

where:

P_{TN} is the total weighted noise power in pWp at Z-interfaces of an output connection.

P_{AN} is the weighted noise power caused by analogue functions according to Annex A/G.123 for Z-interfaces, i.e. 200 pWp (including noise generated by the circuit for level and impedance adaptation).

L_o is the output relative level of the exchange in dB.

L_{IN} is the weighted noise (idle channel noise) for PCM translating equipment for output connections according to Recommendation G.712, i.e. -70 dBm0p.

A.2.3 Weighted noise for a whole connection originating from and terminating in a Z-interface

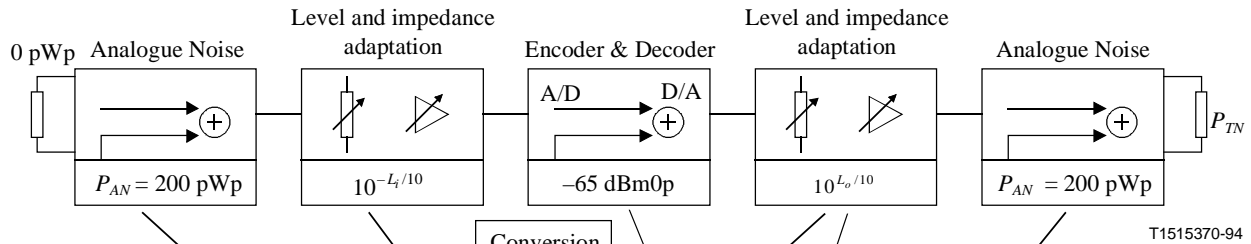

$$P_{TN} = P_{AN} \times 10^{-\left(\frac{L_i - L_o}{10}\right)} + 10^{\left(\frac{90}{10} + \left(\frac{L_{IN} + L_o}{10}\right)\right)} + P_{AN} \text{ (pWp)}$$

$$P_{TN} = P_{AN} \times \left(1 + 10^{\frac{L_o - L_i}{10}}\right) + 10^{\frac{90 + L_{IN} + L_o}{10}} \text{ (pWp)}$$

where:

- P_{TN} is the total weighted noise power in pWp at Z-interfaces of a whole connection through the digital exchange.
- P_{AN} is the weighted noise power caused by analogue functions according to Annex A/G.123 for Z-interfaces, i.e. 200 pWp (including noise generated by the circuit for level and impedance adaptation).
- L_i is the input relative level of the exchange in dBr.
- L_o is the output relative level of the exchange in dBr.
- L_{IN} is the weighted noise (idle channel noise) for PCM translating equipment for whole 2-wire connections according to Recommendation G.712, i.e. -65 dBm0p.

A.2.4 Weighted noise for an input connection originating from a 2-wire or 4-wire C-interface with or without signalling on the speech wires

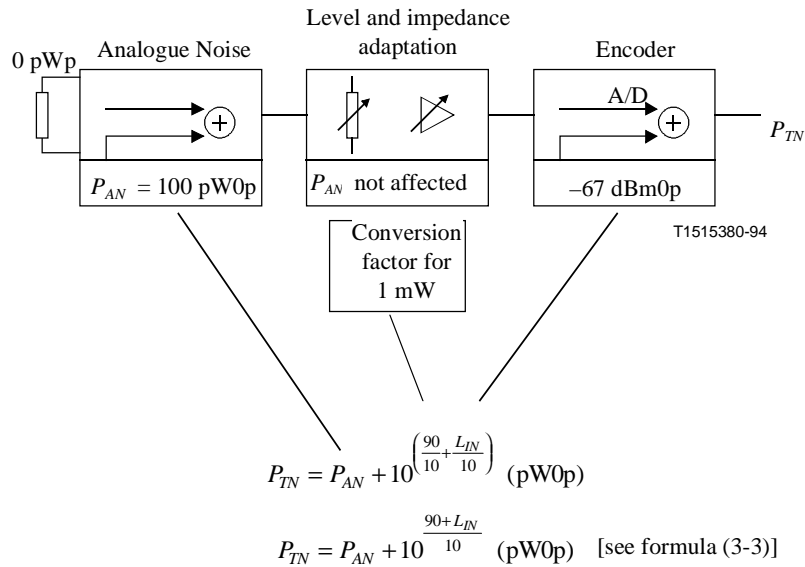

where:

P_{TN} is the total weighted noise power in pW0p at C-interfaces of an input connection.

P_{AN} is the weighted noise power caused by analogue functions according to Annex A/G.123, for:

- C-interfaces with signalling on the speech wires, i. e. 100 pW0p (including noise generated by the circuit for level and impedance adaptation);
NOTE – The 100 pW0p mentioned above result from the 200 pW0p stated in Recommendation G.123 split up to both sides of the connection.
- C-interfaces without signalling on the speech wires 0 pW0p (see Recommendation G.712).

L_{IN} is the weighted noise (idle channel noise) for PCM translating equipment for input connections according to Recommendation G.712, i.e. –67 dBm0p.

A.2.5 Weighted noise for an output connection terminating at a 2-wire C-interface with $L_o \geq -5$ dB or a 4-wire C-interface both with or without signalling on the speech wires

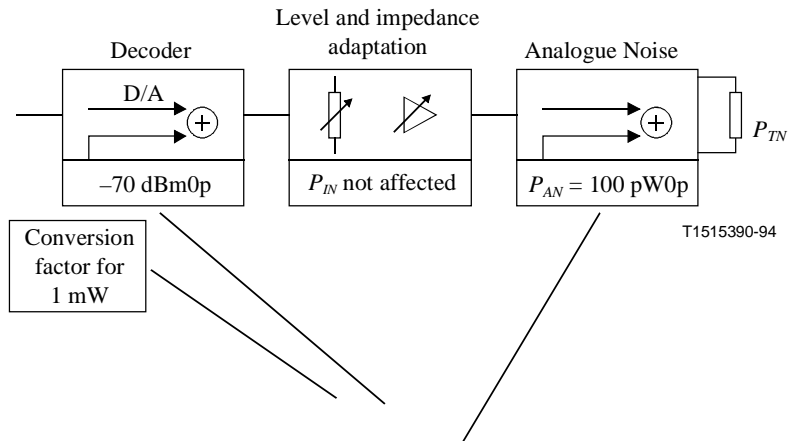

$$P_{TN} = 10^{\left(\frac{90 + L_{IN}}{10} + \frac{L_{IN}}{10}\right)} + P_{AN} \text{ (pW0p)}$$

$$P_{TN} = P_{AN} + 10^{\frac{90 + L_{IN}}{10}} \text{ (pW0p)} \quad [\text{see formula (3-3)}]$$

where:

P_{TN} is the total weighted noise power in pW0p at C-interfaces of an output connection.

P_{AN} is the weighted noise power caused by analogue functions according to Annex A/G.123, for:

- C-interfaces with signalling on the speech wires, i. e. 100 pW0p (including noise generated by the circuit for level and impedance adaptation);

NOTE – The 100 pW0p mentioned above result from the 200 pW0p stated in Recommendation G.123 split up to both sides of the connection.

- C-interfaces without signalling on the speech wires 0 pW0p (see Recommendation G.712).

L_{IN} weighted noise (idle channel noise) for PCM translating equipment for output connections according to Recommendation G.712, i.e. -70 dBm0p.

A.2.6 Weighted noise for an output connection terminating at a 2-wire C-interface with $L_o < -5$ dBr and with or without signalling on the speech wires

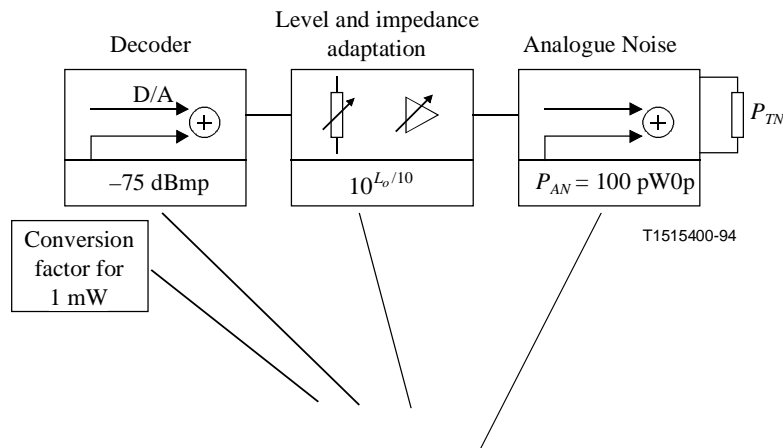

$$P_{TN} = 10^{\left(\frac{90}{10} + \frac{L_{IN}}{10} - \frac{L_o}{10}\right)} + P_{AN} \text{ (pW0p)}$$

$$P_{TN} = P_{AN} + 10^{\frac{90 + L_{IN} - L_o}{10}} \text{ (pW0p)} \quad [\text{see formula (3-4)}]$$

where:

P_{TN} is the total weighted noise power in pW0p at 2-wire C-interfaces of an output connection with $L_o < -5$ dBr.

P_{AN} is the weighted noise power caused by analogue functions according to Annex A/G.123, for:

- C-interfaces with signalling on the speech wires, i. e. 100 pW0p (including noise generated by the circuit for level and impedance adaptation);

NOTE – The 100 pW0p mentioned above result from the 200 pW0p stated in Recommendation G.123 split up to both sides of the connection.

- C-interfaces without signalling on the speech wires 0 pW0p (see Recommendation G.712).

L_o is the output relative level of the exchange in dBr.

L_{IN} is the weighted noise (idle channel noise) for PCM translating equipment for output connections according to Recommendation G.712, i.e. -75 dBmp or 31.6 pWp for relative output levels < -5 dBr for 2-wire interfaces without signalling on the speech wires.

A.2.7 Weighted noise for a whole connection originating from and terminating in 2-wire or 4-wire C-interfaces with or without signalling on the speech wires

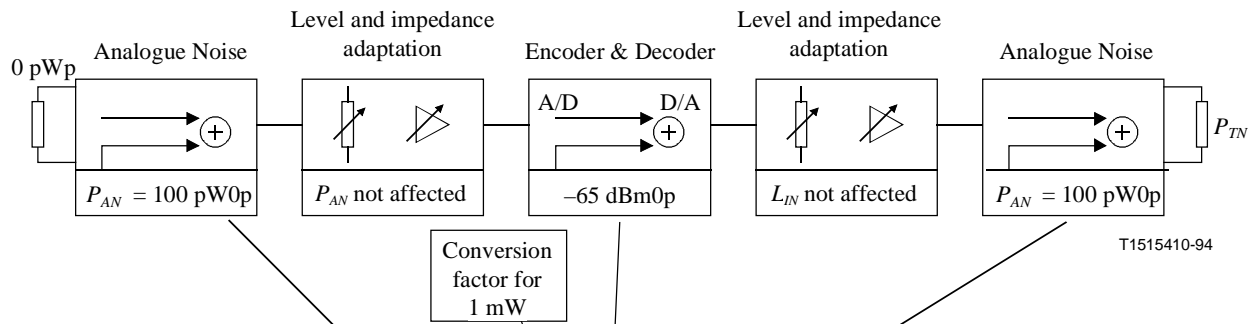

$$P_{TN} = P_{AN} + 10^{\left(\frac{90 + L_{IN}}{10} + \frac{L_{IN}}{10}\right)} + P_{AN} \text{ (pW0p)}$$

$$P_{TN} = 2 \times P_{AN} + 10^{\frac{90 + L_{IN}}{10}} \text{ (pW0p)}$$

where:

P_{TN} is the total weighted noise power in pW0p at C-interfaces of a whole connection through the digital exchange.

P_{AN} is the weighted noise power caused by analogue functions according to Annex A/G.123, for:

- C-interfaces with signalling on the speech wires, i. e. 100 pW0p (including noise generated by the circuit for level and impedance adaptation);
NOTE – The 100 pW0p mentioned above result from the 200 pW0p stated in Recommendation G.123 split up to both sides of the connection.
- C-interfaces without signalling on the speech wires 0 pW0p (see Recommendation G.712).

L_{IN} is the weighted noise (idle channel noise) for PCM translating equipment for:

- whole 2-wire or 4-wire connections according to Recommendation G.712, i.e. –65 dBm0p (–64 dBm0p for relative output levels < –5 dBr for 2-wire interfaces without signalling on the speech wires).

A.3 Total distortion including quantizing distortion

A.3.1 Total distortion including quantizing distortion for an input connection originating from a Z-interface

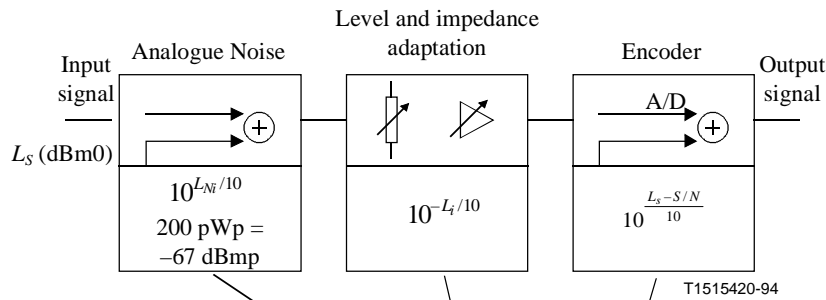

$$S / N_T = L_s - 10 \times \log \left(10^{\left(\frac{L_{Ni}}{10} - \frac{L_i}{10} \right)} + 10^{\left(\frac{L_s - S/N}{10} \right)} \right) \text{ (dB)}$$

$$S / N_T = L_s - 10 \times \log \left(10^{\frac{L_s - S/N}{10}} + 10^{\frac{L_{Ni} - L_i}{10}} \right) \text{ (dB) [see formula (3-5)]}$$

where:

- S/N_T is the resulting signal-to-total distortion ratio in dB for an input connection.
- L_s is the signal level of the measuring signal in dBm0, measured at the output of the connection.
- L_i is the input relative level of the exchange in dBr.
- S/N is the signal-to-total distortion ratio in dB for the PCM translating equipment alone for an input connection according to Figure 12/Q.552.
- L_{Ni} is the weighted noise caused by analogue functions according to Annex A/G.123 (including noise generated by the circuit for level and impedance adaptation), for Z-interfaces, i.e. -67 dBmp.

A.3.2 Total distortion including quantizing distortion for an output connection terminating in a Z-interface

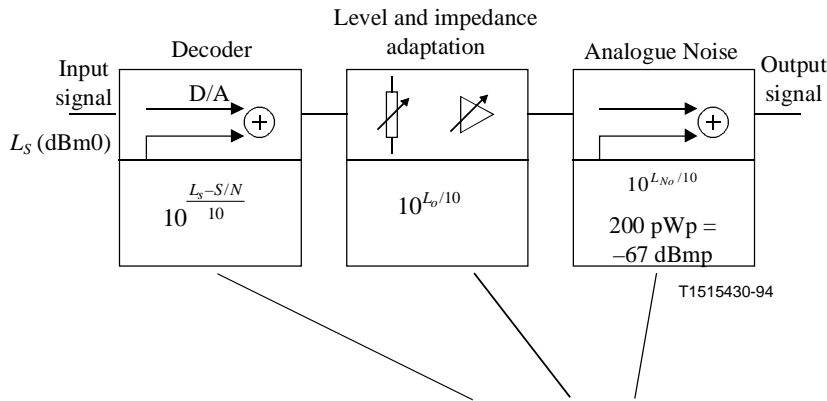

$$S / N_T = L_s + L_o - 10 \times \log \left(10^{\left(\frac{L_s - S/N}{10} \right)} \times 10^{\frac{L_o}{10}} + 10^{\frac{L_{No}}{10}} \right) \text{ (dB)} \quad [\text{see formula (3-6)}]$$

$$S / N_T = L_s - 10 \times \log \left(10^{\frac{L_s - S/N}{10}} + 10^{\frac{L_{No} - L_o}{10}} \right) \text{ (dB)}$$

where:

- S/N_T is the resulting signal-to-total distortion ratio in dB for an output connection.
- L_s is the signal level of the measuring signal in dBm0, measured at the output of the connection.
- L_o is the output relative level of the exchange in dBr.
- S/N is the signal-to-total distortion ratio in dB for the PCM translating equipment alone for an output connection according to Figure 12/Q.552.
- L_{No} is the weighted noise caused by analogue functions according to Annex A/G.123 (including noise generated by the circuit for level and impedance adaptation), for Z-interfaces, i.e. -67 dBmp.

A.3.3 Total distortion including quantizing distortion for a whole connection originating from and terminating in a Z-interface

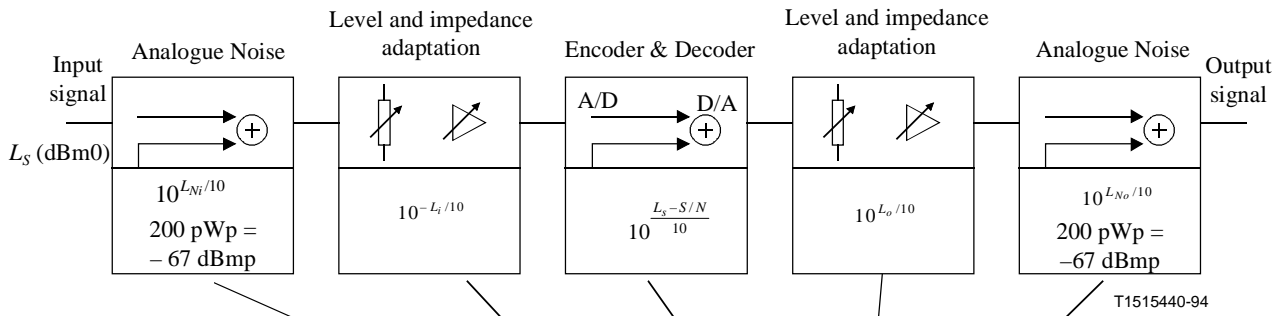

$$S / N_T = L_S + L_o - 10 \times \log \left[\left(10^{\left(\frac{L_{Ni}}{10} - \frac{L_i}{10} \right)} + 10^{\left(\frac{L_s - S/N}{10} \right)} \right) \times 10^{\frac{L_o}{10}} + 10^{\frac{L_{No}}{10}} \right] \text{ (dB)}$$

$$S / N_T = L_S - 10 \times \log \left(10^{\frac{L_{Ni} - L_i}{10}} + 10^{\frac{L_s - S/N}{10}} + 10^{\frac{L_{No} - L_o}{10}} \right) \text{ (dB)}$$

where:

- S/N_T is the resulting signal-to-total distortion ratio in dB for a whole connection through a digital exchange.
- L_S is the signal level of the measuring signal in dBm0, measured at the output of the connection.
- L_i is the input relative level of the exchange in dBr.
- L_o is the output relative level of the exchange in dBr.
- S/N is the signal-to-total distortion ratio in dB for the PCM translating equipment alone for a whole connection according to Figure 11/G.712.
- L_{Ni}, L_{No} is the weighted noise caused by analogue functions according to Annex A/G.123 (including noise generated by the circuit for level and impedance adaptation), for Z-interfaces, i.e. -67 dBmp.

For combinations of Z- and C-interfaces or different types of C-interfaces, similar considerations can be made to obtain the allowed total distortion.

NOTE – The formulae above are applicable to digital exchanges but can also be used for calculating signal-to-total distortion ratio of PCM transmission systems according to Recommendation G.712.

A.3.4 Total distortion including quantizing distortion for an input connection originating from a 2-wire or a 4-wire C-interface

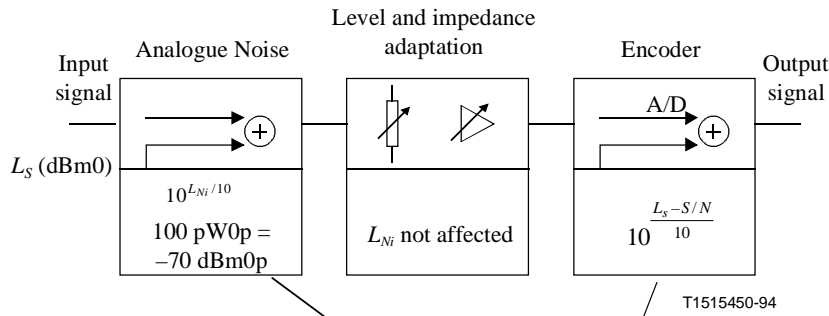

$$S / N_T = L_S - 10 \times \log \left(10^{\frac{L_{Ni}}{10}} + 10^{\left(\frac{L_S - S/N}{10} \right)} \right) \text{ (dB)}$$

$$S / N_T = L_S - 10 \times \log \left(10^{\frac{L_S - S/N}{10}} + 10^{\frac{L_{Ni}}{10}} \right) \text{ (dB)}$$

[see formula (3-7)]

where:

S/N_T is the resulting signal-to-total distortion ratio in dB for an input connection.

L_S is the signal level of the measuring signal in dBm0, measured at the output of the connection.

S/N is the signal-to-total distortion ratio in dB for the PCM translating equipment alone for an input connection according to Figure 12/Q.552.

L_{Ni} is the weighted noise caused by analogue functions according to Annex A/G.123 (including noise generated by the circuit for level and impedance adaptation), for:

- a C-interface with signalling on the speech wires i.e.:

$$-(67 + 3) \text{ dBm0p} = -70 \text{ dBm0p};$$

NOTE – A value of -67 dBm0p is defined in Recommendation G.123 for a whole connection. This noise power is split up equally to the input and output connections resulting in a noise power of:

$$-(67 + 3) \text{ dBm0p} = -70 \text{ dBm0p}$$

- a C-interface without signalling on the speech wires the term $10^{L_{Ni}/10}$ becomes zero.

A.3.5 Total distortion including quantizing distortion for an output connection terminating in a 2-wire or a 4-wire C-interface

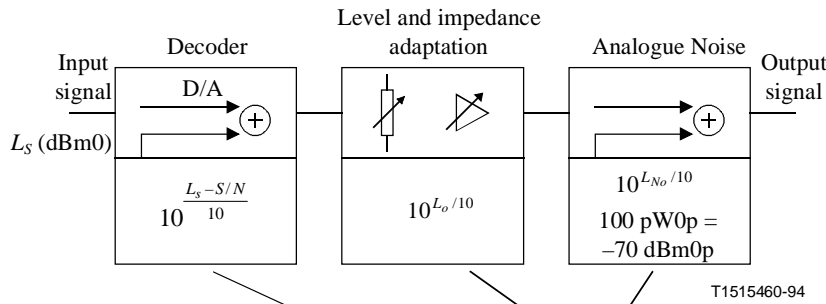

$$S / N_T = L_s + L_o - 10 \times \log \left[\left(10^{\left(\frac{L_s - S/N}{10} \right)} + 10^{\frac{L_{No}}{10}} \right) \times 10^{\frac{L_o}{10}} \right] \text{ (dB)}$$

$$S / N_T = L_s - 10 \times \log \left(10^{\frac{L_s - S/N}{10}} + 10^{\frac{L_{No}}{10}} \right) \text{ (dB) [see formula (3-8)]}$$

where:

S/N_T is the resulting signal-to-total distortion ratio in dB for an output connection.

L_s is the signal level of the measuring signal in dBm0, measured at the output of the connection.

L_o is the output relative level of the exchange in dB.

S/N is the signal-to-total distortion ratio in dB for the PCM translating equipment alone for an output connection according to Figure 12/Q.552.

L_{No} is the weighted noise caused by analogue functions according to Annex A/G.123 (including noise generated by the circuit for level and impedance adaptation), for

- a C-interface with signalling on the speech wires i.e.:

$$-(67 + 3) \text{ dBm0p} = -70 \text{ dBm0p};$$

NOTE – A value of -67 dBm0p is defined in Recommendation G.123 for a whole connection. This noise power is split up equally to the input and output connections resulting in a noise power of:

$$-(67 + 3) \text{ dBm0p} = -70 \text{ dBm0p}.$$

- a C-interface without signalling on the speech wires the term $10^{L_{No}/10}$ becomes zero.

A.3.6 Total distortion including quantizing distortion for a whole connection originating from and terminating in 2-wire or 4-wire C-interfaces

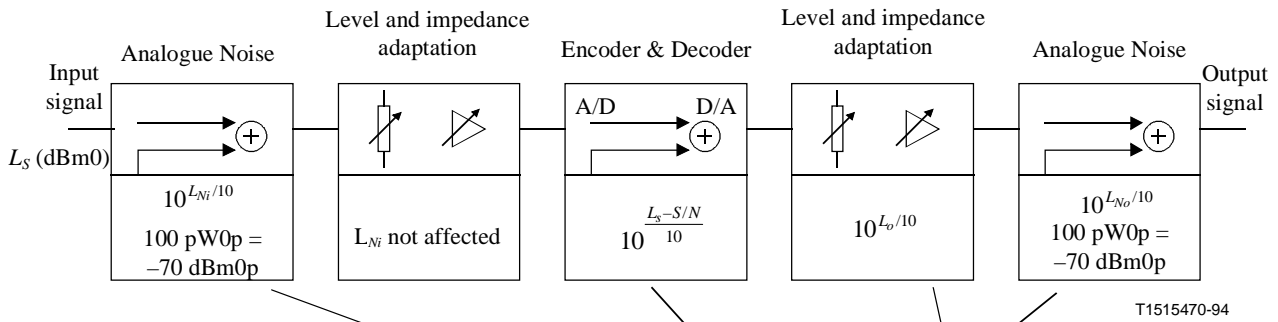

$$S / N_T = L_S + L_o - 10 \times \log \left[\left(\frac{L_{Ni}}{10^{10}} + 10 \left(\frac{L_s - S/N}{10} \right) + 10 \frac{L_{No}}{10^{10}} \right) \times 10 \frac{L_o}{10^{10}} \right] \text{ (dB)}$$

$$S / N_T = L_S - 10 \times \log \left(\frac{L_{Ni}}{10^{10}} + 10 \frac{L_s - S/N}{10} + 10 \frac{L_{No}}{10^{10}} \right) \text{ (dB)}$$

where:

S/N_T is the resulting signal-to-total distortion ratio in dB for a whole connection through a digital exchange.

L_S is the signal level of the measuring signal in dBm0, measured at the output of the connection.

L_o is the output relative level of the exchange in dBr.

S/N is the signal-to-total distortion ratio in dB for the PCM translating equipment alone for a whole connection according to Figure 11/G.712.

L_{Ni}, L_{No} is the weighted noise caused by analogue functions according to Annex A/G.123 (including noise generated by the circuit for level and impedance adaptation), for:

- a C-interface with signalling on the speech wires i.e.:

$$-(67 + 3) \text{ dBm0p} = -70 \text{ dBm0p};$$

NOTE – A value of -67 dBm0p is defined in Recommendation G.123 for a whole connection. This noise power is split up equally to the input and output connections resulting in a noise power of:

$$-(67 + 3) \text{ dBm0p} = -70 \text{ dBm0p}.$$

- a C-interface without signalling on the speech wires the terms $10^{L_{No}/10}$ and $10^{L_{Ni}/10}$ become zero.

For combinations of Z- and C-interfaces or different types of C-interfaces similar considerations can be made to obtain the allowed total distortion.

NOTE – The formulae above are applicable to digital exchanges but can also be used for calculating signal-to-total distortion ratio of PCM transmission systems according to Recommendation G.712.

ANNEX B

Explanation of power, dBm, dBr, dbm0 and mW units of speech band signals in ITU

B.1 Introduction

The question of how to best characterize speech band signal magnitudes, or "power" with a more common expression, is less simple than the use of the word "power" might imply, especially when *complex nominal impedances* have been introduced. The matter has been dealt with in ITU-T documentation in an unambiguous way for quite some time, albeit in a somewhat obscure form. The interpretation therefore sometimes has been subject of confusion and misunderstandings. In what follows the relevant ITU-T methodology will be presented as well as explanations given of why it has been chosen.

Note in particular that the problem of signal magnitude characterization could be handled in many ways and that there is no fundamental, theoretical principle which automatically leads to the one-and-only correct method. Instead, the emphasis has been on *practicality* as a guidance.

B.2 The case of resistive nominal impedances, constant with frequency

Historically, a very early nominal impedance chosen was that of the characteristic impedance of *open wire lines* at speech band frequencies, i.e. 600 ohms resistive, constant with frequency.

A useful concept introduced was that of a sinusoidal *reference signal* passing through a telephone connection. Measurement of the magnitude of this reference signal at various points provided information on loss and gain in the network. One took some care in ensuring that the nominal impedances at the measuring points also were resistive, constant with frequency, although not always 600 ohms. Therefore, the *power* of the reference signal was chosen as the characteristic entity rather than the *voltage*, because the former is invariant with the resistive nominal impedance and the latter not. The reference quantity for the power was chosen to be 1 mW, equivalent with 0.775 volts across 600 ohms.

Thus, if the measured voltage of a sinusoidal signal is U volts across a resistive impedance R ohms its power is:

$$P = \frac{U^2}{0.001R} \text{ mW} \quad (\text{B.2.1})$$

Most often it is practical to work with logarithmic quantities so the (*absolute*) *power level* L was defined as:

$$L = 10 \log \frac{P(\text{mW})}{1(\text{mW})} \text{ dBm} \quad (\text{B.2.2})$$

NOTE – The "m" in "dBm" is most often interpreted as coming from "mW" but it could also refer to "magnitude".

The frequency of the reference signal was originally chosen to be 800 Hz but is now 1020 Hz.

As long as the nominal impedances are resistive and constant with frequency, not only the reference signal but also any other speech band signals can be characterized in magnitude by using equations (B.2.1) and (B.2.2).

The power handling capacity of networks and equipment is conveniently characterized by means of the concept of *reference levels* dBr and *reference points* of 0 dBr. The injection of the reference signal is thought to be so adjusted that, when it passes through a circuit (or equipment), its level at a 0 dBr point becomes just 0 dBm. If the level of the reference signal is L_r at a particular point, that point is designated as having a relative level of L_r dBr.

The magnitude of all other types of signals in the network can be characterized by comparison in level with the reference signal in the same path, i.e. expressed in dBm0 as the *relative power level*.

An advantage of using relative levels for noise contributions along an analogue circuit is the simple method of addition within a circuit. If the noise contributions are respectively N_a , N_b , N_c ..dBm0, the total noise (at the output of the circuit) is:

$$N = 10 \log \left[10^{N_a/10} + 10^{N_b/10} + 10^{N_c/10} + \dots \right] \text{dBm0} \quad (\text{B.2.3})$$

NOTE – The same principle applies for *psophometrically weighted noise*, for which the designations are dBmp and dBm0p for absolute and relative levels respectively.

Finally, it is worth mentioning that the definition of a *flat frequency response* referred to measurements in a set-up with resistive generator and receiver impedances, and where the relation between generator voltage (emf) and the receiver voltage was constant.

B.3 The case of complex nominal impedances, varying with frequency

When the number of long distance calls grew, the influence of the longer delays made echo problems more apparent. Also, the sidetone performance, in many cases, needed improvement when telephone sets were connected via short subscriber lines to digital exchanges. One way to diminish these problems is to be more careful with impedance matching in the 2-wire parts of the network, i.e. to establish a better match between the characteristic impedance of the unloaded subscriber cables and the equipment nominal impedances. This led some Administrations to prescribe *complex nominal impedances* instead of the conventional 600 ohms resistive.

This meant, however, that the way to characterize the magnitude of speech band signals had to be updated from the earlier concept of "power dispersed in a resistive load". In principle, many methods could have been used; however, a discussion of these would lead too far. The method chosen is based on the following principles:

- a) For the reference signal of 1020 Hz, the "magnitude characterization" shall have the same structure for both resistive and complex impedances.
- b) For an equipment being defined as having a flat frequency response, the relation between the generator voltage and the receiver voltage in a measuring set-up shall be constant, irrespective of what the nominal complex impedances are at the generator and receiver sides.

The latter principle corresponds to how most equipment using electronic amplifiers are built up.

The first principle leads to the concept of using the so-called *apparent power* at the reference frequency, i.e. if the nominal impedance at the reference frequency f_0 is $Z_n(f_0)$ and the voltage of the reference voltage is $U(f_0)$ across this, the apparent power is:

$$P = \frac{U(f_0)^2}{0.001 |Z_n(f_0)|} \text{ mVa} \quad (\text{B.3.1})$$

How is the magnitude of a sinusoidal signal at a *frequency* f , *different from* f_0 , to be characterized?

Principle b), the definition of a flat frequency response, leads to its voltage being compared to the voltage at the reference, i.e. a proper measure expressed with the *dimension* of power must use the nominal impedance at the reference frequency. This gives the expression:

$$P = \frac{U(f)^2}{0.001|Z_n(f)|} \text{ mVa} \quad (\text{B.3.2})$$

For a signal composed of a spectrum of frequency components, the value U is to be interpreted as the r.m.s value of the voltage.

Similarly, the concept of relative level as mentioned in B.2 also applies to the case of complex impedance.

For short, one uses the expression "power in mW, pW" and "dBm", "dBm0", etc. to characterize the signal magnitude of speech band signals in conjunction with complex nominal impedances. Note, however, that this power is not to be confused with the concepts of "apparent" or "real" power used in classical analogue filter theory. Note that equation (B.2.3), for addition of noise contributions by using dBm0 values, is still valid in the case of complex nominal impedances.

Reference

For a more complete discussion, see Annex A/G.100 and Recommendation G.101.

ITU-T RECOMMENDATIONS SERIES

- Series A Organization of the work of the ITU-T
- Series B Means of expression
- Series C General telecommunication statistics
- Series D General tariff principles
- Series E Telephone network and ISDN
- Series F Non-telephone telecommunication services
- Series G Transmission systems and media
- Series H Transmission of non-telephone signals
- Series I Integrated services digital network
- Series J Transmission of sound-programme and television signals
- Series K Protection against interference
- Series L Construction, installation and protection of cables and other elements of outside plant
- Series M Maintenance: international transmission systems, telephone circuits, telegraphy, facsimile and leased circuits
- Series N Maintenance: international sound-programme and television transmission circuits
- Series O Specifications of measuring equipment
- Series P Telephone transmission quality
- Series Q Switching and signalling**
- Series R Telegraph transmission
- Series S Telegraph services terminal equipment
- Series T Terminal equipments and protocols for telematic services
- Series U Telegraph switching
- Series V Data communication over the telephone network
- Series X Data networks and open system communication
- Series Z Programming languages