



INTERNATIONAL TELECOMMUNICATION UNION

**ITU-T**

TELECOMMUNICATION  
STANDARDIZATION SECTOR  
OF ITU

**Q.115**

(06/97)

SERIES Q: SWITCHING AND SIGNALLING

Clauses applicable to ITU-T standard systems – Control of  
echo suppressors

---

**Logic for the control of echo control devices**

ITU-T Recommendation Q.115

(Previously CCITT Recommendation)

---

ITU-T Q-SERIES RECOMMENDATIONS  
**SWITCHING AND SIGNALLING**

SIGNALLING IN THE INTERNATIONAL MANUAL SERVICE	Q.1–Q.3
INTERNATIONAL AUTOMATIC AND SEMI-AUTOMATIC WORKING	Q.4–Q.59
FUNCTIONS AND INFORMATION FLOWS FOR SERVICES IN THE ISDN	Q.60–Q.99
CLAUSES APPLICABLE TO ITU-T STANDARD SYSTEMS	Q.100–Q.119
General clauses	Q.100–Q.109
Transmission clauses for signalling	Q.110–Q.114
<b>Control of echo suppressors</b>	<b>Q.115</b>
Abnormal conditions	Q.116–Q.119
SPECIFICATIONS OF SIGNALLING SYSTEMS No. 4 AND No. 5	Q.120–Q.249
SPECIFICATIONS OF SIGNALLING SYSTEM No. 6	Q.250–Q.309
SPECIFICATIONS OF SIGNALLING SYSTEM R1	Q.310–Q.399
SPECIFICATIONS OF SIGNALLING SYSTEM R2	Q.400–Q.499
DIGITAL EXCHANGES	Q.500–Q.599
INTERWORKING OF SIGNALLING SYSTEMS	Q.600–Q.699
SPECIFICATIONS OF SIGNALLING SYSTEM No. 7	Q.700–Q.849
DIGITAL SUBSCRIBER SIGNALLING SYSTEM No. 1	Q.850–Q.999
PUBLIC LAND MOBILE NETWORK	Q.1000–Q.1099
INTERWORKING WITH SATELLITE MOBILE SYSTEMS	Q.1100–Q.1199
INTELLIGENT NETWORK	Q.1200–Q.1999
BROADBAND ISDN	Q.2000–Q.2999

*For further details, please refer to ITU-T List of Recommendations.*

## **ITU-T RECOMMENDATION Q.115**

### **LOGIC FOR THE CONTROL OF ECHO CONTROL DEVICES**

#### **Summary**

Echo is a common problem in long distance telephony, and echo control devices are deployed to eliminate the effects of it. The switching centres involved in a telephony connection must use consistent logical procedures to analyze the available information related to echo control requirements in order to optimize the locations at which echo control devices are provided or inserted in the connection.

This Recommendation defines the information and logical procedures employed within switching centres to optimize echo control device placement. The information elements and logic defined in this Recommendation are applicable to basic telephony calls, and to calls using supplementary services and Intelligent Networking features, in both narrow-band and broadband networks, and should be applied regardless of the particular signalling systems that convey information between the switching centres involved in a connection.

#### **Source**

ITU-T Recommendation Q.115 was revised by ITU-T Study Group 11 (1997-2000) and was approved under the WTSC Resolution No. 1 procedure on the 5th of June 1997.

## FOREWORD

ITU (International Telecommunication Union) is the United Nations Specialized Agency in the field of telecommunications. The ITU Telecommunication Standardization Sector (ITU-T) is a permanent organ of the ITU. The ITU-T is responsible for studying technical, operating and tariff questions and issuing Recommendations on them with a view to standardizing telecommunications on a worldwide basis.

The World Telecommunication Standardization Conference (WTSC), which meets every four years, establishes the topics for study by the ITU-T Study Groups which, in their turn, produce Recommendations on these topics.

The approval of Recommendations by the Members of the ITU-T is covered by the procedure laid down in WTSC Resolution No. 1.

In some areas of information technology which fall within ITU-T's purview, the necessary standards are prepared on a collaborative basis with ISO and IEC.

## NOTE

In this Recommendation, the expression "Administration" is used for conciseness to indicate both a telecommunication administration and a recognized operating agency.

## INTELLECTUAL PROPERTY RIGHTS

The ITU draws attention to the possibility that the practice or implementation of this Recommendation may involve the use of a claimed Intellectual Property Right. The ITU takes no position concerning the evidence, validity or applicability of claimed Intellectual Property Rights, whether asserted by ITU members or others outside of the Recommendation development process.

As of the date of approval of this Recommendation, the ITU had not received notice of intellectual property, protected by patents, which may be required to implement this Recommendation. However, implementors are cautioned that this may not represent the latest information and are therefore strongly urged to consult the TSB patent database.

© ITU 1998

All rights reserved. No part of this publication may be reproduced or utilized in any form or by any means, electronic or mechanical, including photocopying and microfilm, without permission in writing from the ITU.

## CONTENTS

	<b>Page</b>
1 Scope .....	1
2 References .....	2
3 Terms and definitions.....	2
4 Abbreviations .....	3
5 Bearer capabilities for which echo control is required.....	5
6 Arrangements of echo control devices with respect to signalling.....	5
7 Operation without signals.....	6
8 Considerations for ECD control.....	6
8.1 Information used for ECD control.....	6
8.2 Propagation delay counter, call history information.....	7
9 Functions of an exchange initiating echo control.....	8
10 Unavailability of echo control devices.....	8
11 Placement of echo control devices in the network.....	8
12 Handling of echo control devices in the case of different bearer capabilities.....	9
13 Other considerations.....	9
Annex A – Echo control logic .....	10
A.1 General principles and definitions.....	10
A.1.1 General principles .....	10
A.1.2 Definitions.....	10
A.2 Abstract model .....	10
A.2.1 General description .....	10
A.2.2 Signalling system/protocol.....	13
A.2.3 Interworking.....	14
A.2.4 Echo control logic .....	14
Annex B – Echo suppressor control on inter-ISC circuits within a single country.....	31
Annex C – Echo control for ISDN supplementary services.....	32
C.1 Call diversion services.....	32
C.1.1 General .....	32
C.1.2 Use of the echo control procedures.....	32

	<b>Page</b>
C.2 Multi-party services.....	32
C.2.1 General .....	32
C.2.2 Considerations.....	33
C.2.3 Criteria to initiate echo control procedures.....	33
C.2.4 Conference Call, Add-on, and Three-Party Service.....	33
C.2.5 Conference Call, Meet Me .....	34
Appendix I – Transmission of echo control information elements via signalling systems.....	34
Appendix II – Echo control in B-ISDN.....	39
II.1 Indication that echo control is needed.....	39
II.2 Fallback .....	39
II.3 Distribution of echo control devices in B-ISDN networks .....	39
II.4 Propagation delay values.....	40
II.5 End delay requirements .....	41
II.6 Quality of service management.....	41

## **Recommendation Q.115**

### **LOGIC FOR THE CONTROL OF ECHO CONTROL DEVICES**

*(New Delhi, 1960; revised in 1968, 1993 and 1997)*

#### **1 Scope**

The propagation delay in telecommunication networks affects both computer communication protocols and audiovisual communication between humans. The most noted effect is the echo problem for telephony which depends heavily on the propagation delay of the connection.

In order to achieve transmission objectives on long connections (refer to item j), clause 3), it is necessary to take into account the effects of echo. A general discussion of echo considerations is given in Recommendation G.131 [6]. The characteristics of terminal half-echo control devices are given in Recommendation G.164 [1]. The characteristics of echo cancellers are given in Recommendation G.165 [2].

In order to achieve optimum echo control for each call, it is necessary to control both echo suppressors and echo cancellers.

This can be carried out at switching centres only if sufficient information is available to coordinate an overall control action.

Logical means to obtain pertinent information and the switching considerations governing its practicable use are detailed below. Control based on the transfer of signals between switching centres is given particular attention. Self-contained control action such as tone disablement of echo suppressors and echo cancellers for data transmission is not within the scope of this clause.

The target to be reached by the use of echo control logic is:

- to optimize the location of provision/insertion of Echo Control Devices (ECD). The echo control logic should select an ECD as near to the echo source (hybrid or terminal equipment) as possible. The ECD should be close enough to the source of echo so that its echo control tail length is sufficient to cancel any echo that may be present;
- to provide information about the insertion/provision of ECD in the connection in the forward and in the backward direction.

Where it is appropriate to extend the echo control methods and logic into national networks, this is subject to national guidelines.

The delay time counter procedures require the addition of transmission delay values, beginning at the origin of a call and ending at the destination of it. These values could only be representative, if the whole or at least most of the delay of the connection is considered.

If the configuration of a call is changed after the call set-up (e.g. a new leg is added to a conference call), the exchange having knowledge about this change is responsible to initiate the echo control logic procedures for this new configuration (see Annex C).

Echo control logic, i.e. the set of echo control logic procedures, covers the needs of echo control not only in the PSTN but also in the ISDN, B-ISDN and PLMN. It is also capable of adaptation to the changing requirements in connections supporting services such as call forwarding and multiparty calls. It is independent of the signalling systems/protocols involved, but the optimal placement may depend on the capability of the signalling systems. Echo control logic described in this Recommendation is compatible with the logic described in previous versions.

For new versions of signalling systems/protocols it is necessary to define parameters and messages to transmit the echo control information and requests as specified in Annex A.

It is outside the scope of this Recommendation to determine when signalling messages are initiated.

## 2 References

The following ITU Recommendations and other references contain provisions which, through reference in this text, constitute provisions of this Recommendation. At the time of publication, the editions indicated were valid. All Recommendations and other references are subject to revision; all users of this Recommendation are therefore encouraged to investigate the possibility of applying the most recent edition of the Recommendations and other references listed below. A list of the currently valid ITU-T Recommendations is regularly published.

- [1] CCITT Recommendation G.164 (1988), *Echo suppressors*.
- [2] ITU-T Recommendation G.165 (1993), *Echo cancellers*.
- [3] CCITT Recommendation I.230 (1988), *Definition of bearer service categories*.
- [4] CCITT Recommendation G.172 (1988), *Transmission plan aspects of international conference calls*.
- [5] ITU-T Recommendation G.173 (1993), *Transmission planning aspects of the speech service in digital public land mobile networks*.
- [6] CCITT Recommendation G.131 (1988), *Stability and echo*.
- [7] CCITT Recommendation E.220 (1992), *Interconnection of Public Land Mobile Networks (PLMN)*.
- [8] ITU-T Recommendation Q.764 (1993), *ISDN user part signalling procedures*.
- [9] ITU-T Recommendation Z.100 (1993), *CCITT Specification and description language (SDL)*.
- [10] CCITT Recommendation Q.271 (1988), *Continuity check of the speech path: General*.
- [11] CCITT Recommendation Q.724 (1988), *Telephone user part signalling procedures*.
- [12] CCITT Recommendation Q.112 (1988), *Signal levels and signal receiver sensitivity*.
- [13] ITU-T Recommendation Q.2764 (1995), *Signalling System No. 7 B-ISDN User Part B-ISUP – Basic call procedures*.

## 3 Terms and definitions

- a) Subsequent discussion of control measures will refer to the standard terminal half-echo suppressor specified in Recommendation G.164 [1] and the echo cancellers specified in Recommendation G.165 [2]. The terms "echo suppressor" and "echo canceller" will be used to denote these devices. The term "ECD" will comprise both echo suppressors and echo cancellers.
- b) Two means of introducing ECDs are considered as acceptable. These are the use of permanently associated echo control devices, and the use of echo control devices inserted from a common pool.
- c) With respect to control of permanently associated ECDs, control actions are said to enable or disable.



- d) With respect to echo control devices provided from pools, control actions are concerned with inserting or not inserting. An inserted ECD is controlled in order to enable or disable it.
- e) With respect to ECD provided in B-ISDN exchanges, the term "ECD" denotes echo cancellers only, as echo suppressors should not be used.
- f) Information to assist in the placement of echo control devices is communicated between exchanges by ITU-compliant signalling.
- g) Full ECD describes the situation where both an outgoing echo control device and an incoming echo control device [see item k) in clause 3 below] are enabled at a single exchange.
- h) A **long circuit** is considered as one which, if used by itself, would require echo control.
- i) A **short circuit** is considered as one which, if used by itself, would not require echo control.
- j) A **long connection** is a connection that requires echo control.  
A long connection may consist of several circuits in tandem. These circuits may or may not be long circuits, but their total propagation delay is such that echo control is required.  
If not detected at call set-up time, the total propagation delay is calculated during call set-up based on information carried in signalling (see 8.2.).
- k) An **incoming echo control device (IECD)** is a device cancelling the echo returned from the destination network with reference to the direction in which the call is set up.  
An **outgoing echo control device (OECD)** is a device cancelling the echo returned from the network of origin with reference to the direction in which the call is set up.
- l) Two types of exchanges are defined:  
**exchange Type 1** invokes echo control logic procedures for all calls of the bearer capability "speech or 3.1 kHz audio". These procedures are described in this Recommendation. Any exchange in a network can be of the Type 1.  
**exchange Type 2** can not invoke echo logic control procedures. The received echo control information is passed unchanged (in both directions). In case of interworking the echo control information is mapped from one signalling system/protocol to the other.
- m) An **echo control initiating exchange** is the first exchange that recognizes the need to apply echo control procedures.
- n) The **propagation delay initiating exchange** is the exchange that initiates the propagation delay determination procedure, e.g. a typical case is the originating local exchange.
- o) The **propagation delay terminating exchange** is the exchange that terminates the propagation delay determination procedure, e.g. typically the local destination exchange.

#### 4 Abbreviations

This Recommendation uses the following abbreviations:

B-ISDN	Broadband ISDN
B-ISUP	Signalling System No. 7 Broadband ISDN User Part Recommendations Q.2761-Q.2764 (approved 1995)
CHI	Call History Information
CII	Control Information for IECD
CIO	Control Information for OECD
ECD	Echo Control Device

ECIB	Echo Control Information Backward
ECIBA	Echo Control Information Backward, Additional (ECD availability)
ECIBAp	Procedure to set the information in ECIBA
ECIBp	Procedure to set the information in the ECIB passed to the previous exchange when ECIB has been received from the subsequent exchange
ECIF	Echo Control Information Forward
ECIF/Ap	Procedure that is called when selecting an outgoing circuit
ECIFA	Echo Control Information Forward, Additional (ECD availability)
ECIFAp	Procedure for handling echo control information received from the previous exchange in ECIFA
ECIFp	Procedure for handling echo control information received from the previous exchange in ECIF
ECRB	Echo Control Request Backward (OECD request/IECD request)
ECRBp	Procedure for handling information in a backward echo control request
ECRF	Echo Control Request Forward (OECD request/IECD request)
ECRFp	Procedure for handling a forward request message (e.g. after fallback) when no ECDs are available in a previous exchange
I.a.	Incoming echo control device available
I.i.	IECD included
I.n.a.	Incoming echo control device not available
I.n.i.	IECD not included
I.n.r.	IECD not requested
I.r.	IECD requested
IECD	Incoming Echo Control Device
ISUP'92	Signalling System No. 7 ISDN User Part Recommendations Q.761-Q.764 (approved March 1993)
N-ISDN	Narrow-band ISDN
NOECDIp	Procedure called by ECIFp if no ECDs are in the connection up to this point
O.a.	Outgoing echo control device available
O.i.	OECD included
O.n.a.	Outgoing echo control device not available
O.n.i.	OECD not included
O.n.r.	OECD not requested
O.r.	OECD required/requested
OECD	Outgoing Echo Control Device
OECDRp	Procedure called by ECIFp when a previous exchange has requested this exchange to provide an OECD
OECDIp	Procedure called by ECIFp when a previous exchange has included an OECD
PDC	Propagation Delay Counter
T	If propagation delay > T, then echo control device(s) is (are) required (if at least one of the accesses has a source of echo) (refer to Recommendation G.131 [6])

## **5 Bearer capabilities for which echo control is required**

For connections controlled by ISUP'92 or later versions, the echo control logic procedures apply to the following bearer capabilities:

- 3.1 kHz audio or speech; and
- 64 kbit/s unrestricted preferred

For connections controlled by B-ISUP, echo control applies when the Narrow-band Bearer Capability parameter is present in the B-ISUP Initial Address Message with the information transfer capability values:

- 3.1 kHz audio or speech.

The SDL flowchart of Annex A summarizes the actions described in clause 9 related to the analysis of information and the decision to be taken in an exchange.

The handling of ECDs in the case of different bearer capabilities is described in clause 12; the considerations for ECD as from ISUP'92 are described in clause 8.

The considerations for ECD by ITU Signalling System No. 7 B-ISUP are described in Appendix II.

If the whole connection is controlled by ISUP'92 or later versions, clause 8.2 applies.

## **6 Arrangements of echo control devices with respect to signalling**

Arrangements should be incorporated in the switching equipment to prevent echo control device action from disturbing simultaneous forward and backward in-band signalling via the speech paths.

Arrangements should be incorporated in the Systems No. 6 and No. 7 equipment to prevent actions by echo control devices from disturbing the procedure for making the continuity check of the speech path. Echo control devices must be permanently disabled if a circuit is used as a signalling channel for common channel signalling.

Echo control devices must be enabled when signalling indicates that a call has encountered fallback from 64 kbit/s preferred to speech/3.1 kHz audio (see 2.5/Q.764) if echo control is required for the call.

Typical arrangements are:

- i) locating the echo control devices in a position that does not lead to interference with signalling tones;
- ii) where echo control devices are located in a position where they interfere with signalling tones, they must be capable of being disabled by an appropriate condition extended from the signalling equipment to the ECD while signalling is in progress;
- iii) using an echo control device that is designed to be transparent to signalling tones (see Note 3 below).

NOTE 1 – The standard half-echo suppressor (see Recommendation G.164 [1]) if located on the line side of line signalling equipment may adversely affect signalling. This difficulty is possible because with the new standard half-echo suppressor normal operation will at times cause 6 dB additional loss to appear in the path to a line signalling receiver. Operating margins are correspondingly reduced. For example, with signalling receivers for System No. 5 as specified in Recommendation Q.112 [12], signalling reliability could be impaired. Accordingly, adequate operating margins should be assured or the echo suppressor should not be located on the line side of line signalling receivers. With regard to inter-register signalling which requires simultaneous transmission in both directions, similar considerations call for disabling the echo suppressors while inter-register signalling is in progress in order to prevent the 6 dB loss.

NOTE 2 – Echo cancellers will not introduce any fixed loss during in-band signalling. But some can cause a problem during the continuity check used in Signalling Systems No. 6 (see Recommendation Q.271 [10]) and No. 7 (see Recommendations Q.724 [11] and Q.764 [8]), or with compelled signals having the same frequency(ies) on both directions of transmission in Signalling System No. 5 (see Recommendation Q.112 [12]) where the received signal is processed through the existing echo path model and produces an interfering signal in the return path.

NOTE 3 – Some echo control devices are capable of internally providing either signalling bypass or an appropriate internal function which permits transparent operation to in-band signalling or other in-band tones.

## **7 Operation without signals**

In Signalling Systems No. 5 and R1, signals are not available for echo control information. In System No. 4, a signal may be applied only if multilateral or bilateral agreements authorize its use. Accordingly, the recommended control plan relies on means other than signals in cases where it has not been found practicable to provide signals. In the case of System No. 5, the normal field of application to long circuits typically indicates the presence of echo control devices. In the case of System R1, regional control procedures not requiring signals are applicable.

## **8 Considerations for ECD control**

### **8.1 Information used for ECD control**

Exchanges must make decisions with respect to echo control requirements at the time an outgoing circuit is selected or at a later stage of call set-up. Unless echo control devices are not available, one or more of the following items of information should influence this decision:

- i) address information indicating the destination (e.g. country code, area code);
- ii) information about the actual routing of the call (this includes information related to the routing of a call to a destination, and to any interaction with intelligent network entities);
- iii) nature of outgoing circuit (e.g. satellite circuit);
- iv) nature of incoming circuit;
- v) signalling information received in forward and backward direction:
  - I.i. IECD included
  - I.n.i. IECD not included
  - I.r. IECD requested
  - I.n.r. IECD not requested
  - O.i. OECD included
  - O.n.i. OECD not included
  - O.r. OECD required/requested

- O.n.r. OECD not requested
- O.a. Outgoing echo control device available (Note)
- I.a. Incoming echo control device available (Note)
- O.n.a. Outgoing echo control device not available
- I.n.a. Incoming echo control device not available;
- vi) bearer capability requested (see clause 12.);
- vii) propagation delay counter, call history information.

NOTE – O.a. and I.a. also apply for accesses with no source of echo.

With respect to iii) and iv), the characteristic of primary interest is propagation time. Two general categories, long and short, are the basis of control action. See h) and i) in clause 3 above, for definition of terminology.

Signalling procedures convey echo control information to enable exchanges to perform echo control in a call dependent way. For example, see 2.6/Q.764, 2.7/Q.764 and Annex C/Q.764 [8]

Echo control logic will not result in an echo control device being provided in an exchange while that exchange is interacting with Intelligent Network entities during call set-up. The echo control logic will use routing or other information from call control to detect that the exchange is interacting with Intelligent Network entities. Echo control logic is invoked at the completion of Intelligent Network interactions when the onward routing of the call is determined. The echo control logic uses the echo control information that was received in the IAM, and was stored until needed. Echo control logic on a temporary connection to an Intelligent Peripheral is for further study.

Considerations for the use of echo control in B-ISDN are described in Appendix II/Q.115.

## 8.2 Propagation delay counter, call history information

Some signalling protocols provide procedures to determine the total propagation delay for a connection in order to have better means to evaluate the need for echo control on the connection concerned.

The propagation delay information is accumulated during call set-up in the forward direction. The result is sent in the backward direction as call history information before the active phase of the call. This accumulated result normally represents the propagation delay of the whole connection. However, if the propagation delay terminating exchange has knowledge of the propagation delay of a possible succeeding part of the connection, the value of this delay will be added to the value of the propagation delay as received and the total value will be returned in the call history information. The call history information can be used at a later time during the call set-up.

The propagation delay initiating exchange has the possibility to start accumulating the propagation delay with a value  $> 0$ . The initiating exchange may set the propagation delay counter to a fixed value stored in the exchange.

The increment of the propagation delay counter is 1 ms, the maximum delay value is  $2^{16} - 1$  ms.

The propagation delay counter is accumulated for every link in the connection for every call, if possible.

The propagation delay may not be used by every exchange for the decision to include echo control devices into a connection.

As not all exchanges support the propagation delay counting, the other criteria listed in 8.1. have to be used for echo control.

## **9 Functions of an exchange initiating echo control**

All exchanges of Type 1 involved in a connection determine by factors i) to vii) in 8.1. above whether echo control devices are needed in the connection. If there is no need to provide echo control devices in a particular connection, then there is no distinction between these exchanges.

If the information related to the factors i) to vii) indicates that the connection to be established will require echo control devices, the following distinction is made:

The exchange that first detects the requirement for echo control devices becomes the EC initiating exchange. This exchange has the responsibility for the optimum placement of the OECD.

If the EC initiating exchange has detected the requirement for echo control devices during forward call set-up, then that exchange has the responsibility for the optimum placement of an OECD. The EC Initiating exchange either requests the preceding exchange/network to provide an OECD (when it has information that an OECD is available in the preceding exchange/network) or it provides an OECD. The EC initiating exchange informs the succeeding exchange/network that an OECD is being included, if this is possible on the outgoing signalling system/protocol.

If the EC initiating exchange has detected the requirement for echo control devices during backward call set-up, then that exchange has the responsibility for the optimum placement of an IECD. The EC initiating exchange provides the IECD. The EC initiating exchange informs the preceding exchange/network that an IECD has been included, if this is possible on the incoming signalling system/protocol.

Information on the action to be taken when an EC initiating exchange is unable to provide an IECD or OECD on the connection is provided in clause 10.

See clause 11 for information regarding the possibility of an exchange providing both an OECD and an IECD.

In the event that an EC initiating exchange is unable to provide an outgoing ECD when a need is known, it may call for cooperative action. (Signal I-11 in Signalling System R2 is specifically assigned to make possible a cooperative transfer of responsibility for ECD control from an outgoing gateway exchange – being the EC initiating exchange – to the transit exchange.) The EC logic in an EC initiating exchange will not cause a negotiation process (similar to that used in ISUP'92) to enable an OECD in the preceding exchange/network when it has no knowledge that an OECD is available in the preceding exchange/network.

## **10 Unavailability of echo control devices**

It is recognized that when ECDs are inserted from pools, there is a small probability that no ECD will be available when needed. In this case, the echo control may be done by another exchange. Where EC logic recognizes that proper echo control is not in the connection, the call may be either allowed to complete or terminated. This decision is outside the scope of this Recommendation.

## **11 Placement of echo control devices in the network**

The objective of the EC logic is to select an outgoing echo control device and an incoming echo control device as near as possible to the sources of echo.

ECDs should be placed in such a position in the network that the echo cancellation tail length is sufficient to cover the round-trip end delay between the ECD and the source of echo.

Echo control devices in a connection should preferably be provided in the proper sequence. This means the incoming echo control device should be placed after the outgoing echo control device, seen in the direction of call set-up.

It follows from the above that in every case where a transit exchange interconnects two circuits and knows that ECD will be provided at a preceding location and also at a more distant location, the transit centre may disable or not insert its own ECD. It is recognized that a full ECD is possible in which the IECD and the OECD are located in the same exchange. However, control logic covering full ECD has not been included in this Recommendation and is left for further study. The provision of tandem ECD for transit calls may be considered provided it does not result in degradation of the call.

No arrangement is made in echo control logic to deactivate an OECD once it is placed and activated. Description and logic to deactivate an existing OECD will be included in echo control items for further study.

Information about placement of echo control devices for PLMN to PSTN or ISDN interworking is given in Recommendations G.173 [5] and E.220 [7].

## **12 Handling of echo control devices in the case of different bearer capabilities**

Echo control logic is invoked when the bearer capability information indicates that it is appropriate.

Different bearer capabilities are needed to provide the different services. Where common circuits are used to provide different basic services, ECDs have to be enabled depending on the requested service, and the results of echo control logic.

- If the bearer capability is speech or 3.1 kHz audio, an ECD should be enabled for this connection at the appropriate exchanges when echo control is required.
- If the bearer capability is 64 kbit/s unrestricted or multirate, or if digital connectivity is requested in TUP, no ECD is inserted. If the ECD is permanently associated, these ECDs have to be disabled and provide bit transparency.
- If the bearer capability is 64 kbit/s preferred, an ECD should be provided in the disabled mode for this connection, at the appropriate exchanges. If the bearer capability for the call changes to speech/3.1 kHz audio from 64 kbit/s preferred, the ECDs should then be enabled.

Echo control procedures to support the change of bearer capability during any phase of a call are for further study.

## **13 Other considerations**

Nothing in this Recommendation should be construed as discouraging control measures which may supplement the plan described and lead to improved results in specific situations. For example, regional procedures which introduce loss to control echo may be arranged to satisfy both regional and international needs on a selective basis. In addition, for multiple ISCs in one country, the procedure of Annex B may be applied. It is recognized that possibilities for echo control have not been exhausted. If switching and signalling equipment have a changed role in the application of future procedures, this Recommendation will be subject to revision.

## ANNEX A

### Echo control logic

#### A.1 General principles and definitions

##### A.1.1 General principles

The echo control logic is based on the following principles:

- Echo control devices can be either fix assigned to the circuits or arranged in a pool (the probability of the availability of an echo control device in the pool should be very close to 1). Either method of providing ECDs will adequately meet the needs of network services and supplementary services.
- Reservation of ECDs is not considered in this logic, as it would cause unnecessary complications in signalling procedures.
- Evaluation of propagation delay counter, if present.
- Evaluation of call history information, if present.
- Connections with only one echo control device (OECD or IECD) are treated as a regular case, i.e. these connections are not released.
- Future signalling systems/protocols are required to transmit ECIFA, indicating whether a preceding exchange/network has the possibility to provide an OECD if required (Note 1).
- Future signalling systems/protocols are required to transmit ECIBA, indicating whether a succeeding exchange/network has the possibility to provide an IECD if required (Note 2).

NOTE 1 – Incoming circuits (supported by signalling systems/protocols not capable of transmitting ECIFA) connected to an exchange where the availability of OECD in a preceding exchange/network is known, are marked accordingly (this allows an exchange to send an explicit request for OECD backward, only if it makes sense). Where the availability of ECD in the preceding network is not known, the default value of "ECD not available" should be used.

NOTE 2 – Outgoing circuits (supported by signalling systems/protocols not capable of transmitting ECIBA) connected to an exchange where the availability of IECD in a succeeding exchange/network is known, are marked accordingly (this allows an exchange to send an explicit request for IECD forward, only if it makes sense). Where the availability of ECD in the succeeding network is not known, the default value of "ECD not available" should be used.

##### A.1.2 Definitions

- An exchange of Type 1 contains echo control logic (see Figure A.1).
- An exchange of type 2 does not contain echo control logic (see Figure A.2).

#### A.2 Abstract model

##### A.2.1 General description

Echo control logic is part of call control and has a common interface to the logic procedures of the incoming and outgoing signalling systems/protocols.

Echo control logic provides information to populate the echo control indicators in signalling messages.



The following information elements are interchanged between echo control logic and the signalling systems/protocol involved in setting up the connection:

- *Echo Control Information Forward (ECIF)*
  - O.n.i. OECD not in the connection
  - O.i. OECD in the connection
  - O.r. OECD required in subsequent exchange
- *Echo Control Information Backward (ECIB)*
  - I.n.i. IECD not in the connection
  - I.i. IECD in the connection
- *Echo Control Request Forward (ECRF)*
  - I.n.r. IECD not required
  - I.r. IECD required
  - O.r. OECD required
  - O.n.r. OECD not required
- *Echo Control Request Backward (ECRB)*
  - I.n.r. IECD not requested
  - I.r. IECD requested
  - O.r. OECD requested
  - O.n.r. OECD not requested
- *Echo Control Information Forward, Additional (ECIFA)*
  - O.n.a. OECD not available in preceding exchange/network
  - O.a. OECD available in preceding exchange/network (Note 3)
- *Echo Control Information Backward, Additional (ECIBA)*
  - I.n.a. IECD not available in succeeding exchange/network
  - I.a. IECD available in succeeding exchange/network (Note 3)
- *Control Information for IECD (CII)*
  - Enable (see clauses 6 and 12)
  - Disable
- *Control Information for OECD (CIO)*
  - Enable (see clauses 6 and 12)
  - Disable

NOTE 3 – O.a. and I.a. also apply for accesses with no source of echo.

The following information is available from call control (routing):

- Propagation Delay Counter (PDC) (Note 4)
  - Received:  $PDC = D_i$
  - Sent forward:  $PDC = D_i + D_o$
- Call History Information (Note 4)
  - total propagation delay sent backward

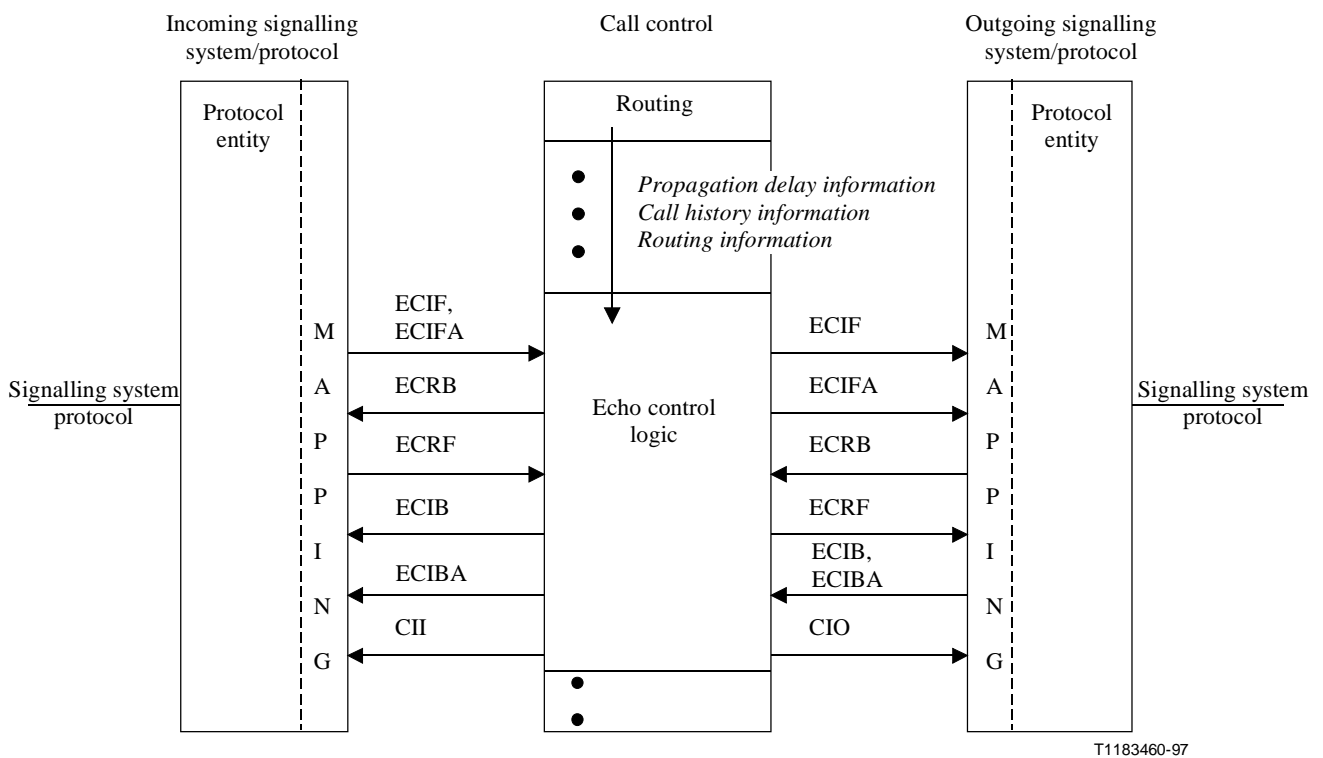
- **Routing Information**

this includes information related to the routing of a call to a destination, and to any interaction with intelligent network entities.

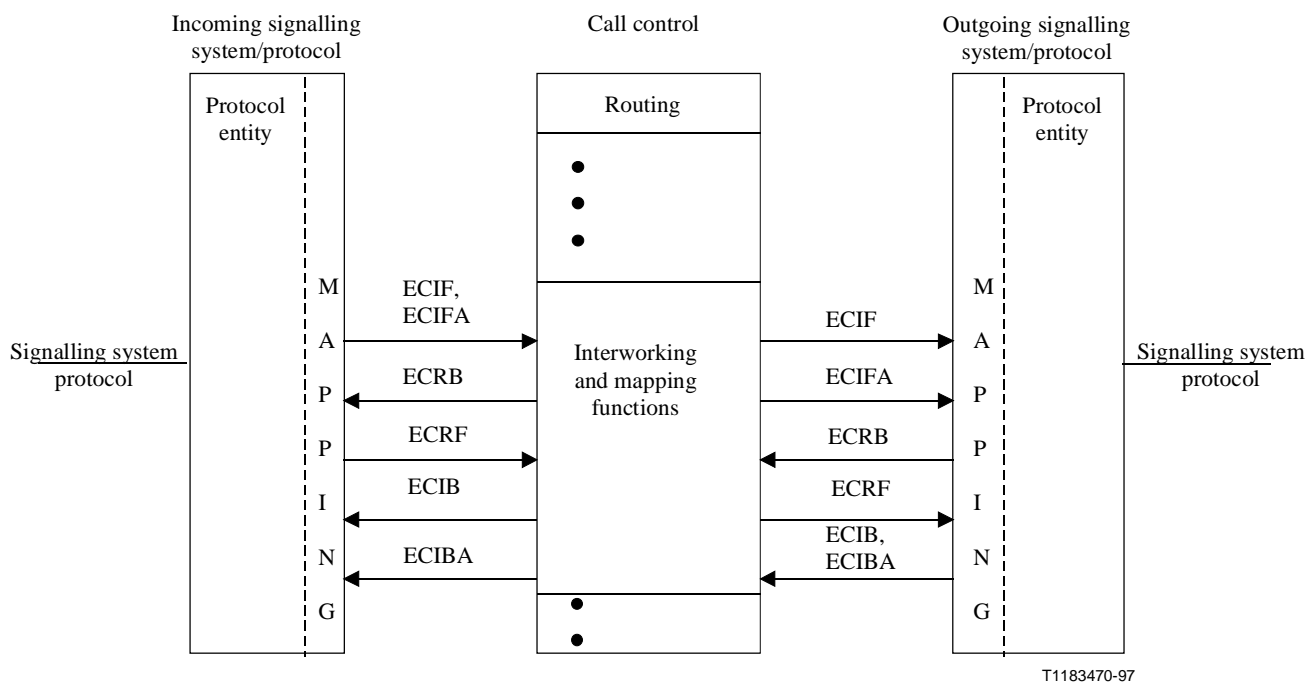
NOTE 4 – Di Propagation Delay time of the originating access, or of the incoming connection (PDC received)

Do Propagation delay of the terminating access, or of the outgoing section of the connection.

If propagation delay > T then echo control is required.



**Figure A.1/Q.115 – Exchange Type 1**



**Figure A.2/Q.115 – Exchange Type 2**

## A.2.2 Signalling system/protocol

### A.2.2.1 General

The echo control information/requests received by the signalling systems/protocols have to be stored so that they can be interpreted by the echo control logic procedures (see A.2.1); ECIF has to be sent in conjunction with ECIFA (if not supported by the signalling system/protocol, a default value based on the knowledge of the adjacent exchange/network has to be used). The same applies for ECIB and ECIBA. The protocol entity of the signalling systems/protocols is responsible for the control of the echo control devices. The signalling systems/protocols transmit the echo control information/requests resulting from echo control logic. See Table I.1 for details of the transmission of echo control information.

### A.2.2.2 Backward compatibility

Some existing signalling systems/protocols have echo control signalling procedures based on their signalling information transfer capabilities. These signalling procedures may not adhere fully to the echo control logic described in this Recommendation. Therefore, a backward compatibility mechanism may be required in an exchange using the echo control logic defined in this Recommendation in conjunction with signalling procedures of ISUP'97. The figures in Appendix I show examples of such mechanisms.

### A.2.2.3 Interactions with intelligent networking

The protocol entity is responsible for providing default echo control values in a backward direction when interaction to intelligent networking entities occurs during call set-up. Echo control information received in an IAM is stored during this period. If an answer message is required to allow user-network interaction, it should not include call history information. The default values for the echo control information are "I.n.i." and "I.n.a.". This is applicable to both Type 1 and Type 2 exchanges.

### **A.2.3 Interworking**

In case of exchange Type 2 the received echo control information/requests are mapped (by the interworking function) from one signalling system/protocol to the other.

### **A.2.4 Echo control logic**

#### **A.2.4.1 Echo control logic procedures**

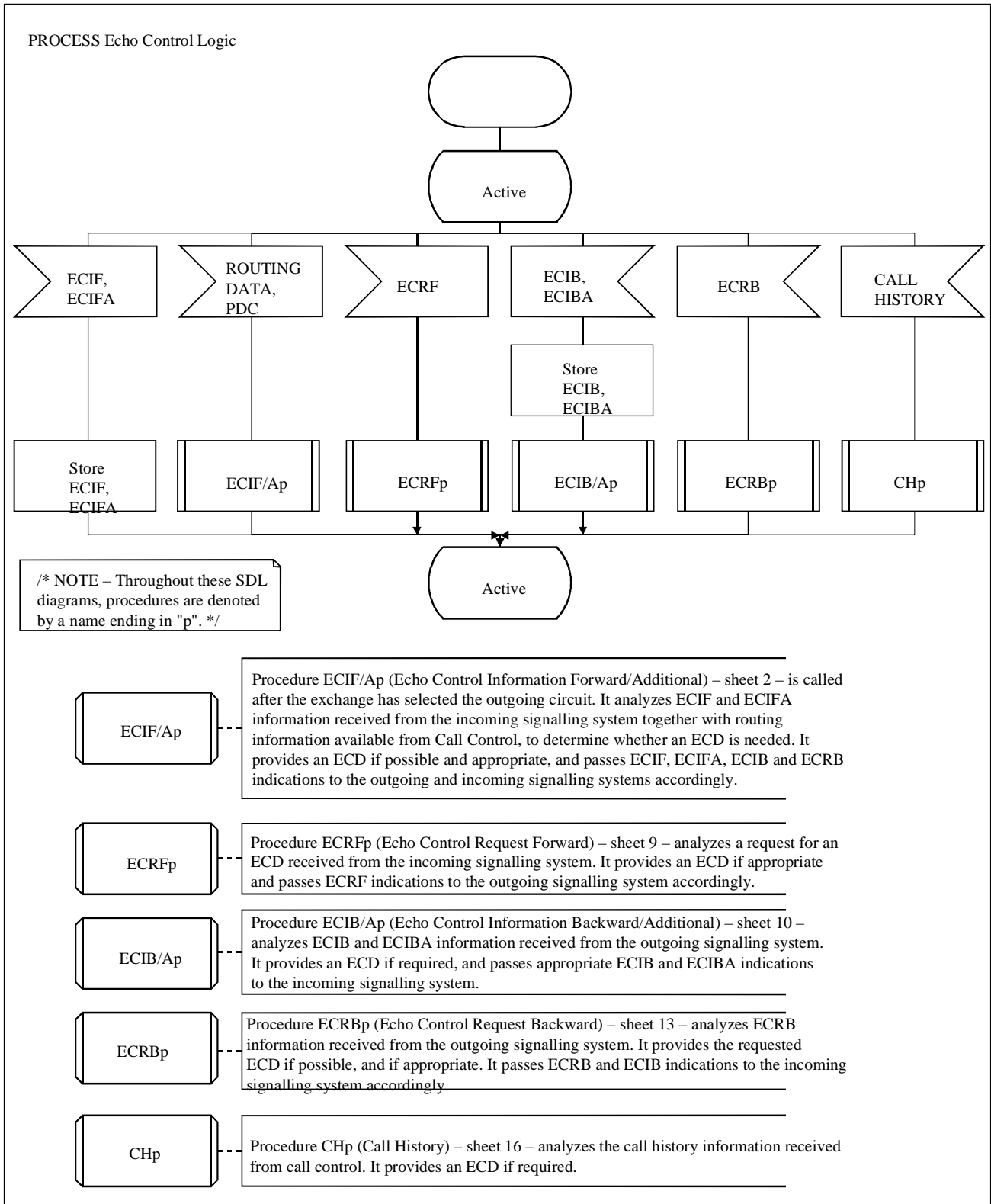
The echo control logic procedures are based on the echo control information/requests and propagation delay/call history values received via the signalling systems/protocols as well as on origin/destination related information that is stored in the database of the exchange. Based on all these data the echo control logic procedures determine:

- a) echo control device related actions; and
- b) the echo control information/requests that have to be transmitted by the signalling systems/protocols.

The echo control logic procedures do not directly control the echo control devices. It is the task of the protocol entity of the signalling systems/protocols to disable and enable echo control devices. The reason is: The echo control logic procedures do not know if e.g. in-band signalling is still going on, if continuity check is still running, or the value of the currently used bearer capability.

#### **A.2.4.2 SDL diagrams for echo control logic procedures**

The following pages (Figures A.3 to A.18) show the echo control logic procedures. Refer to Recommendation Z.100 [9] for definitions of the symbols and syntax used in these diagrams.



T1183480-97

Figure A.3/Q.115 (sheet 1 of 16)

/\* Echo Control Information Forward/Additional.  
This procedure is called when selecting the outgoing circuit. \*/

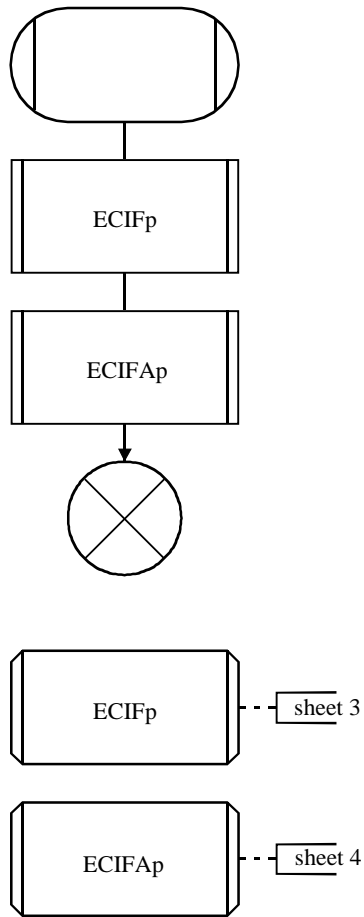
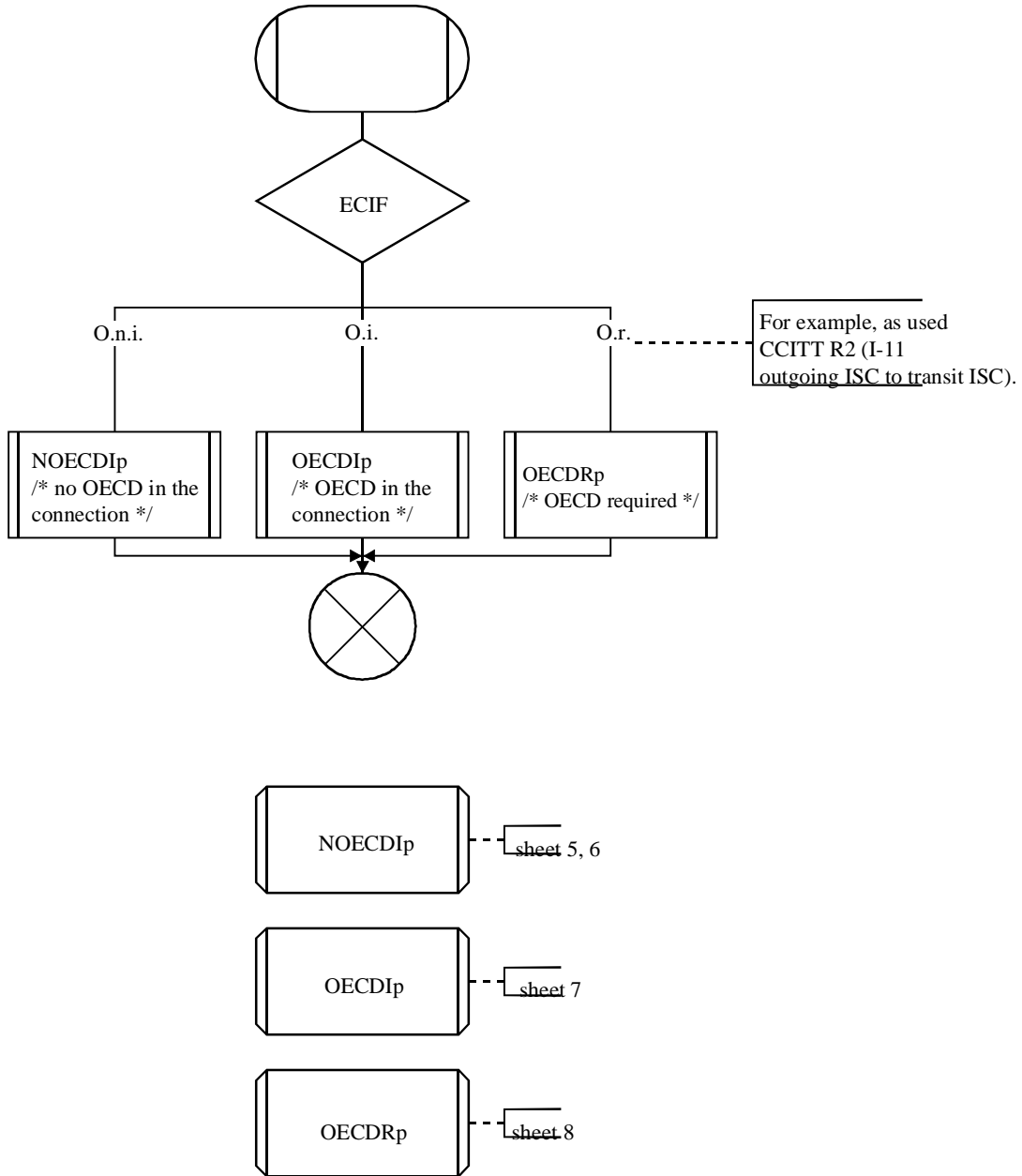


Figure A.4/Q.115 (sheet 2 of 16)

PROCEDURE ECIFp;

/\* Echo Control Information Forward  
This procedure is called by procedure ECIF/Ap sheet. \*/



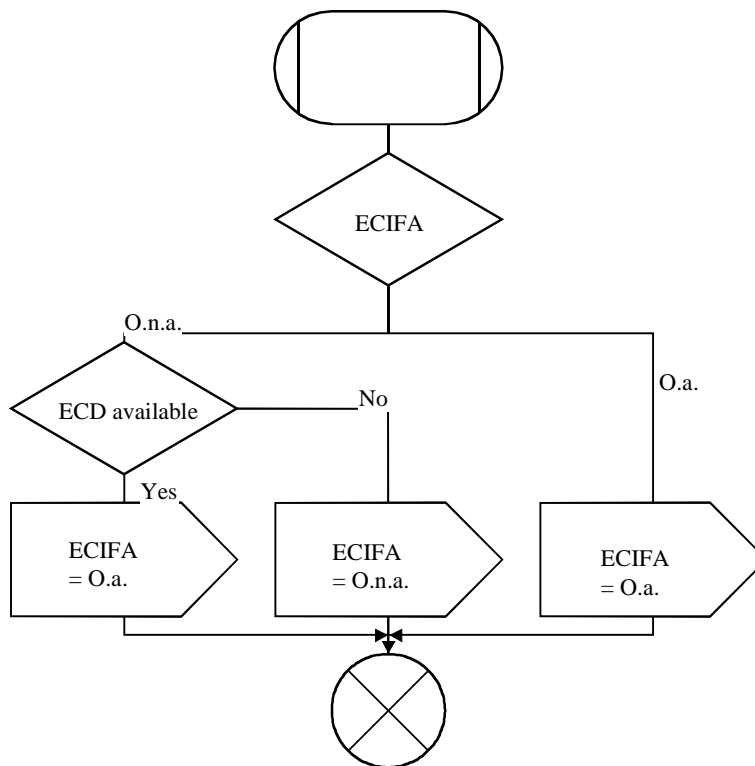
T1183500-97

Figure A.5/Q.115 (sheet 3 of 16)

PROCEDURE ECIFAp;

/\* Echo Control Information Forward Additional

This procedure is called by procedure ECIF/Ap when an exchange having the capability to process Echo Control Information/ Additional (ECIFA) is selecting an outgoing circuit. It sets the ECIFA information to O.a. or O.n.a. as appropriate, to indicate the availability of an OECD in this, or a preceding exchange. \*/



T1183510-97

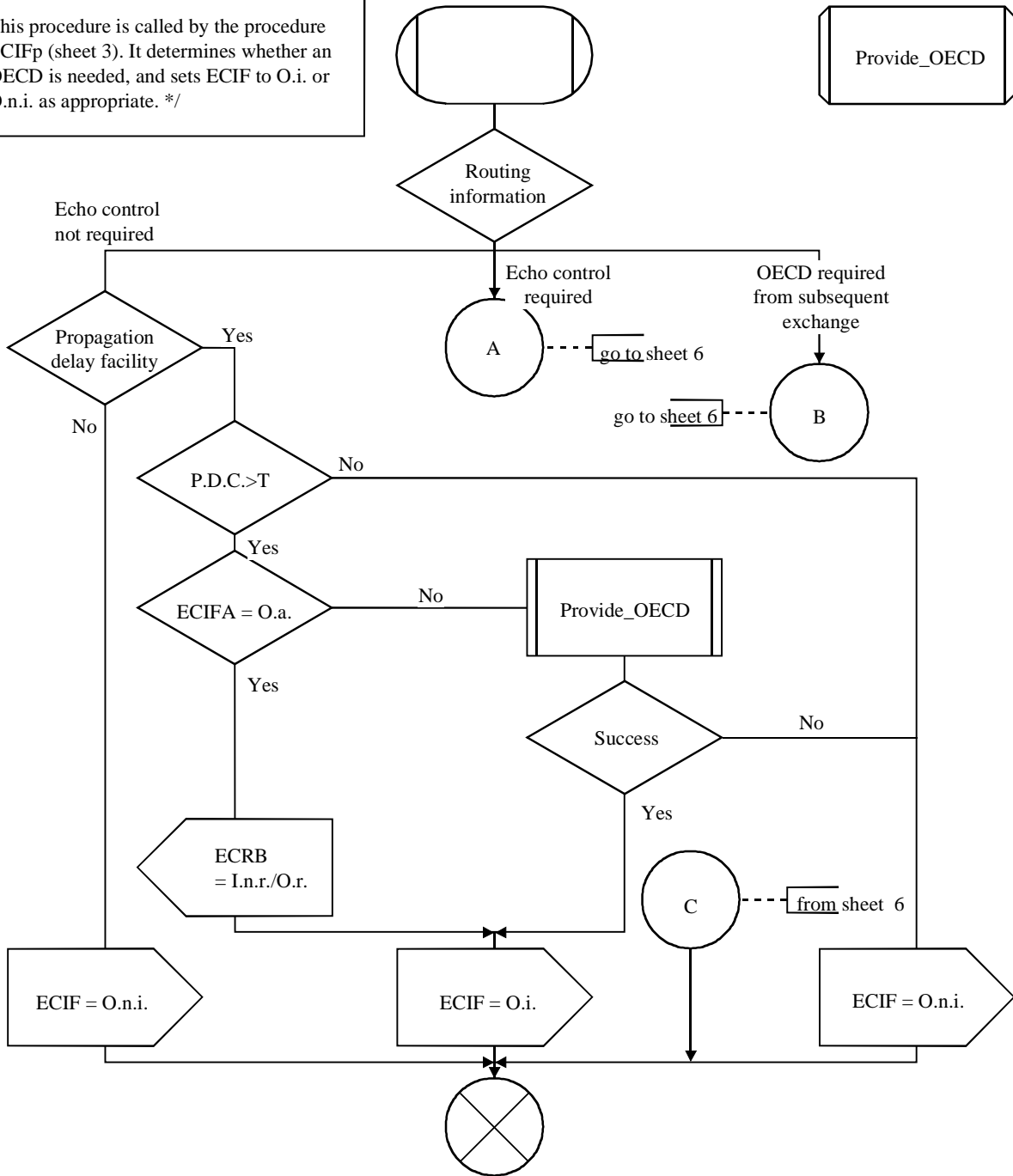
Figure A.6/Q.115 (sheet 4 of 16)



PROCEDURE NOECDIp;

/\* No OECD in the connection up to here.

This procedure is called by the procedure ECIFp (sheet 3). It determines whether an OECD is needed, and sets ECIF to O.i. or O.n.i. as appropriate. \*/



T1183520-97

Figure A.7/Q.115 (sheet 5 of 16)

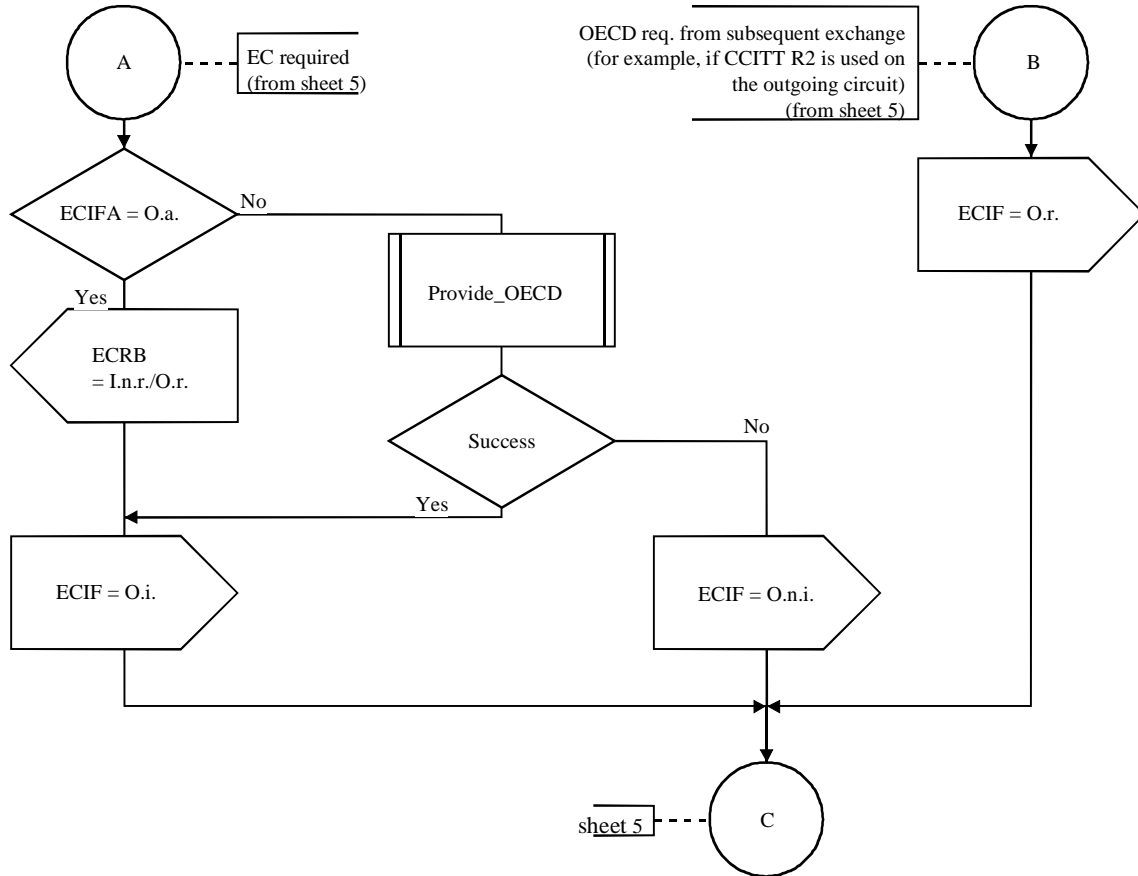
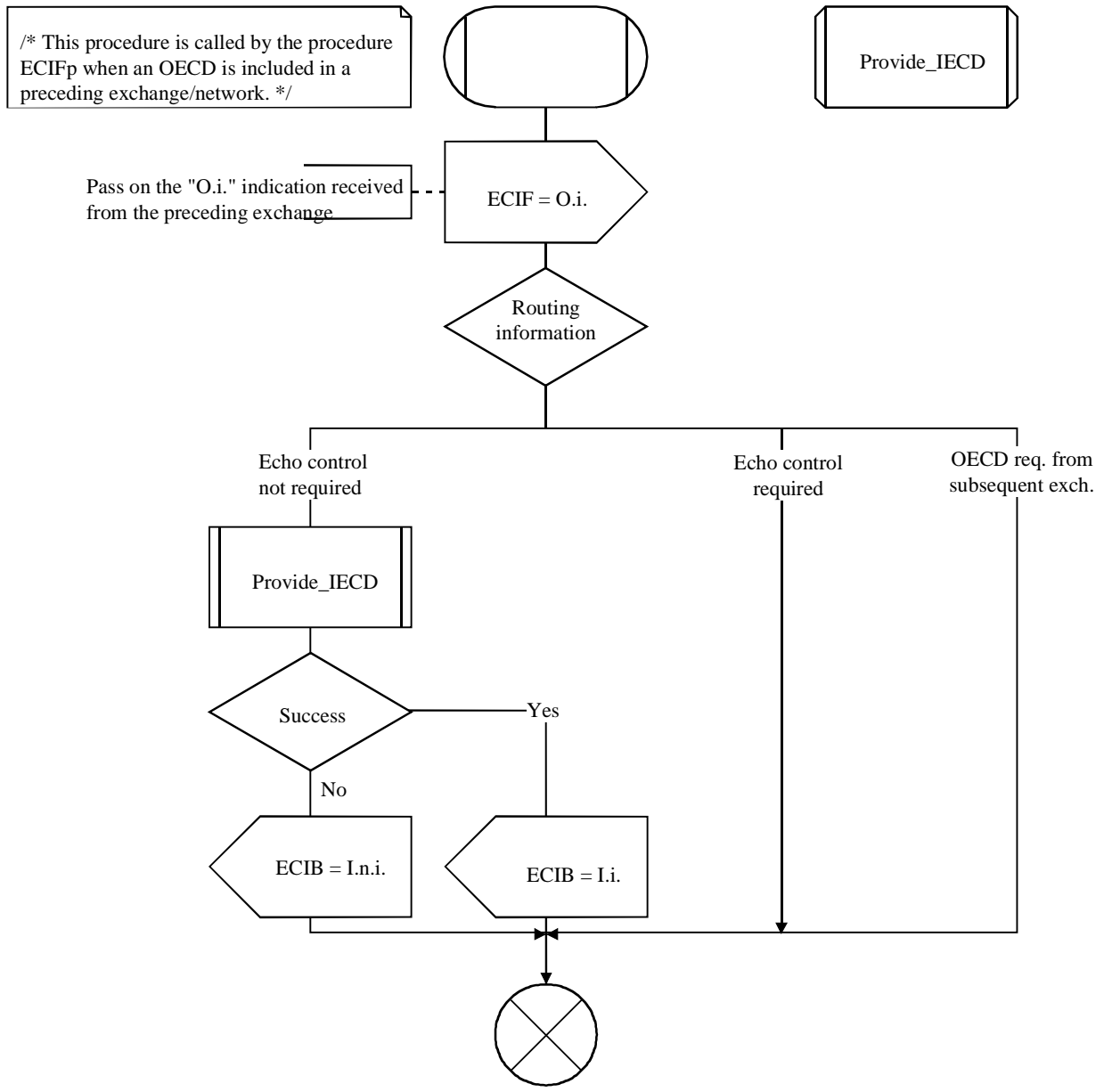


Figure A.8/Q.115 (sheet 6 of 16)

PROCEDURE OECDIp;



T1183540-97

Figure A.9/Q.115 (sheet 7 of 16)

/\* This procedure is called by the procedure ECIFp when the preceding exchange requests this exchange to provide an OECD; e.g. CCITT R2. \*/

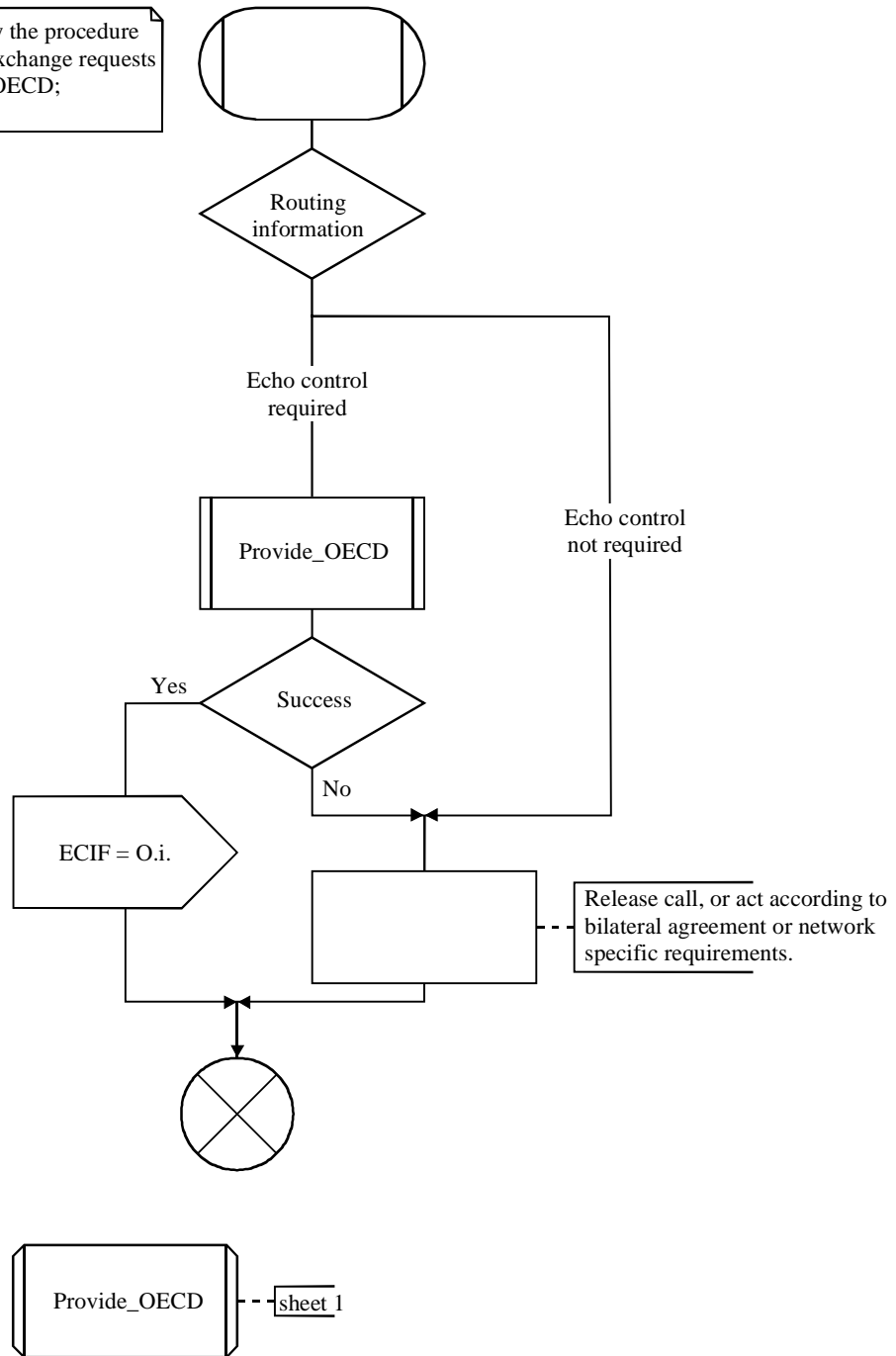


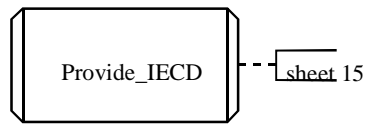
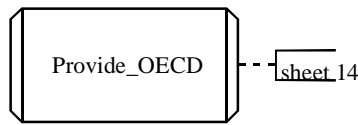
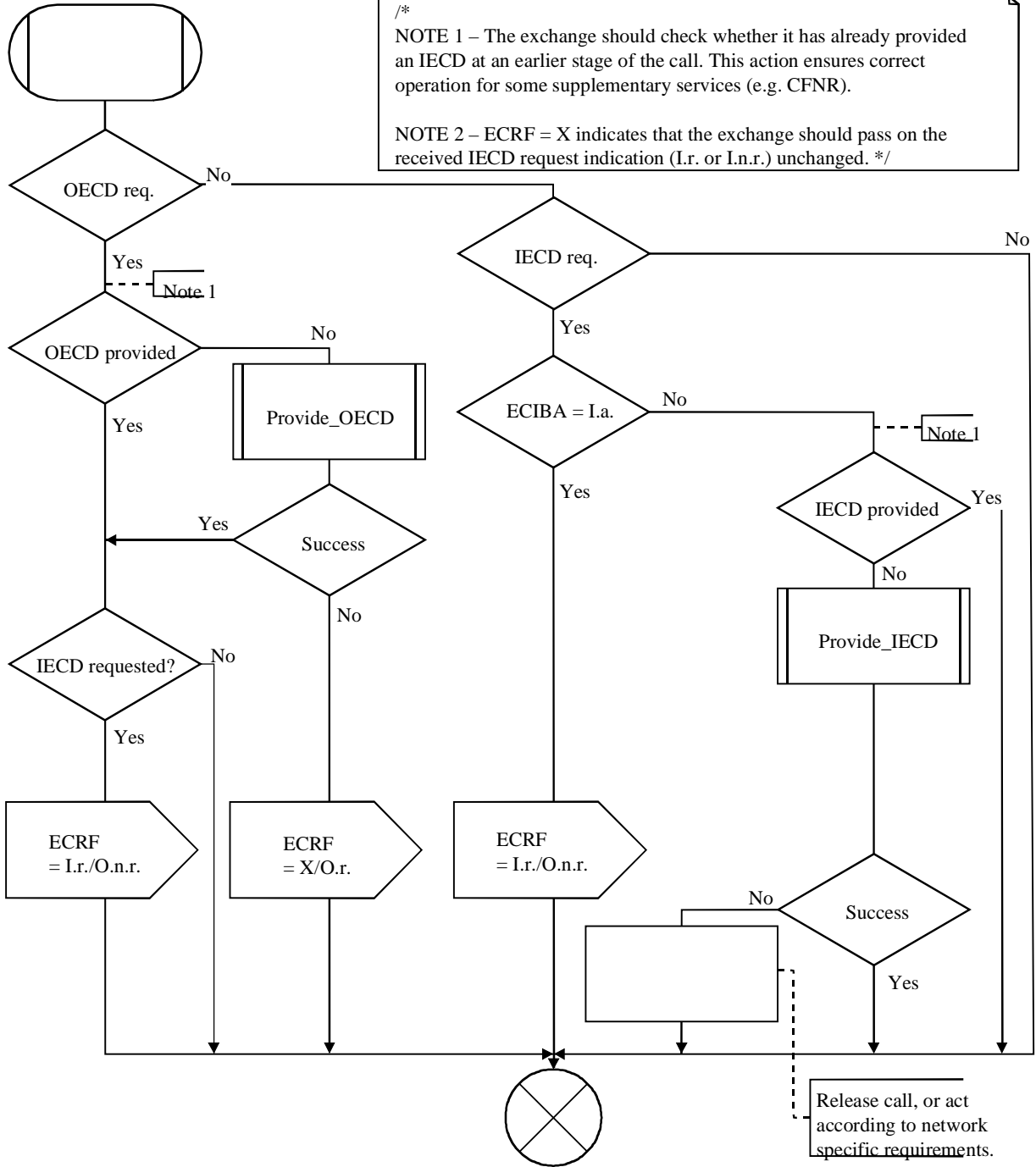
Figure A.10/Q.115 (sheet 8 of 16)

PROCEDURE ECRFp;

/\* This procedure is called when receiving a forward request; e.g. after fallback has occurred in a preceding exchange, where no ECDs are available. \*/

/\* NOTE 1 – The exchange should check whether it has already provided an IECD at an earlier stage of the call. This action ensures correct operation for some supplementary services (e.g. CFNR).

NOTE 2 – ECRF = X indicates that the exchange should pass on the received IECD request indication (I.r. or I.n.r.) unchanged. \*/

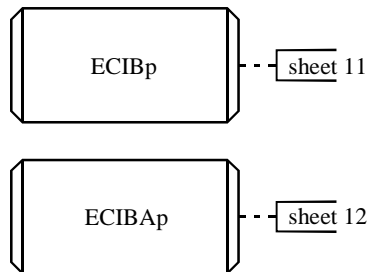
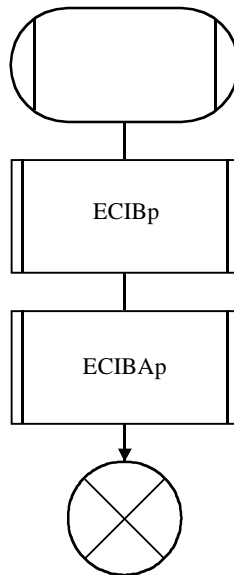


T1183560-97

Figure A.11/Q.115 (sheet 9 of 16)

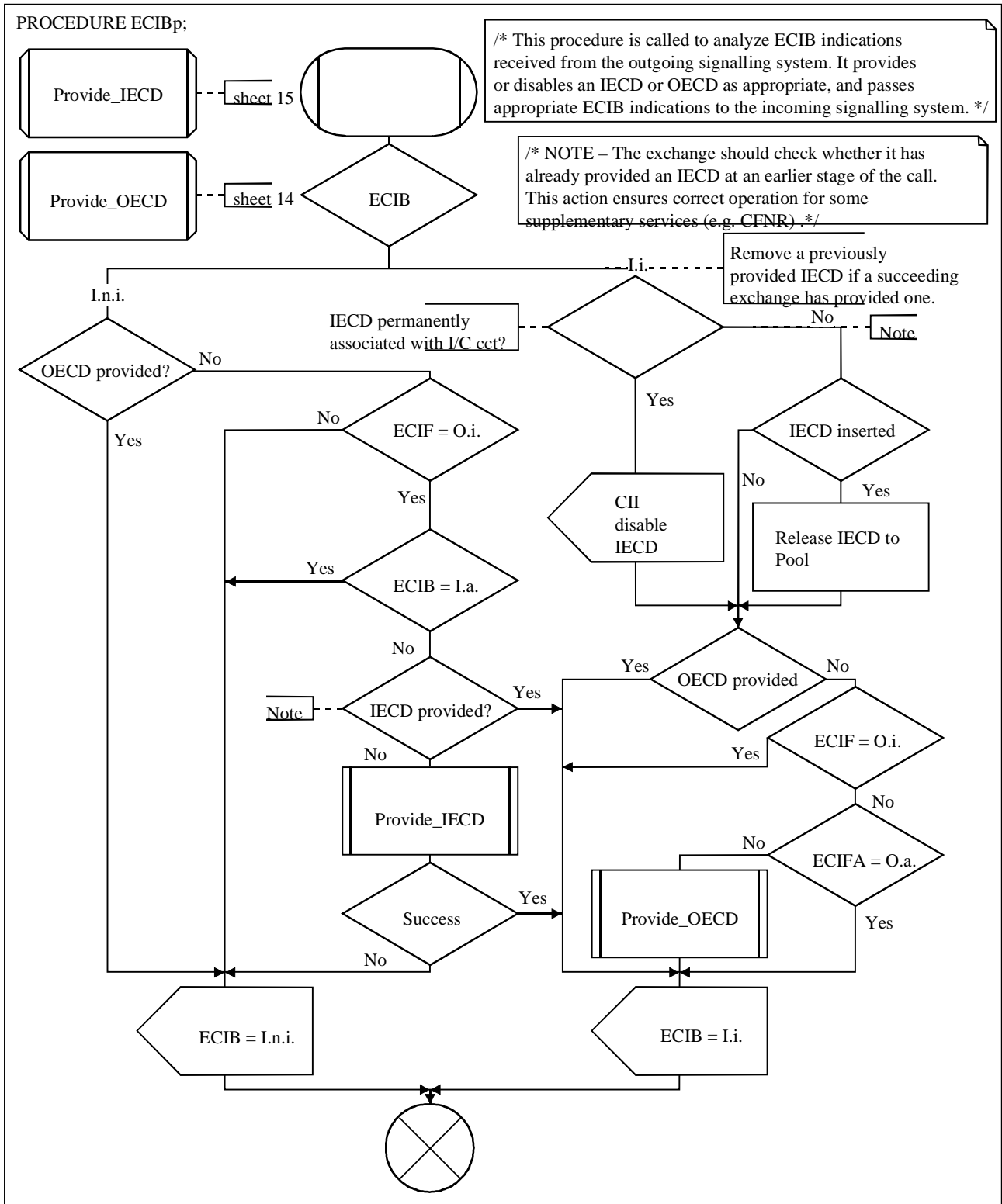
PROCEDURE ECIB/Ap;

/\* This procedure is called to process Echo Control Device Information and Call History Information received in the Backward direction. \*/



T1183570-97

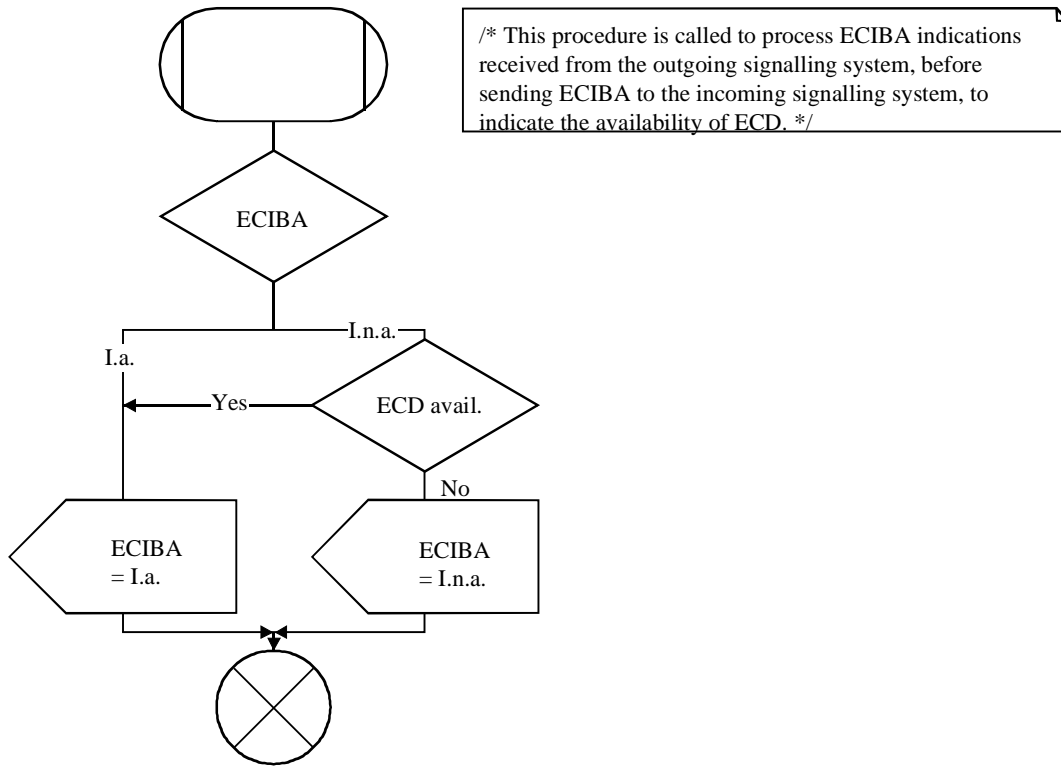
Figure A.12/Q.115 (sheet 10 of 16)



T1183580-97

Figure A.13/Q.115 (sheet 11 of 16)

PROCEDURE ECIBAp;



T1183590-97

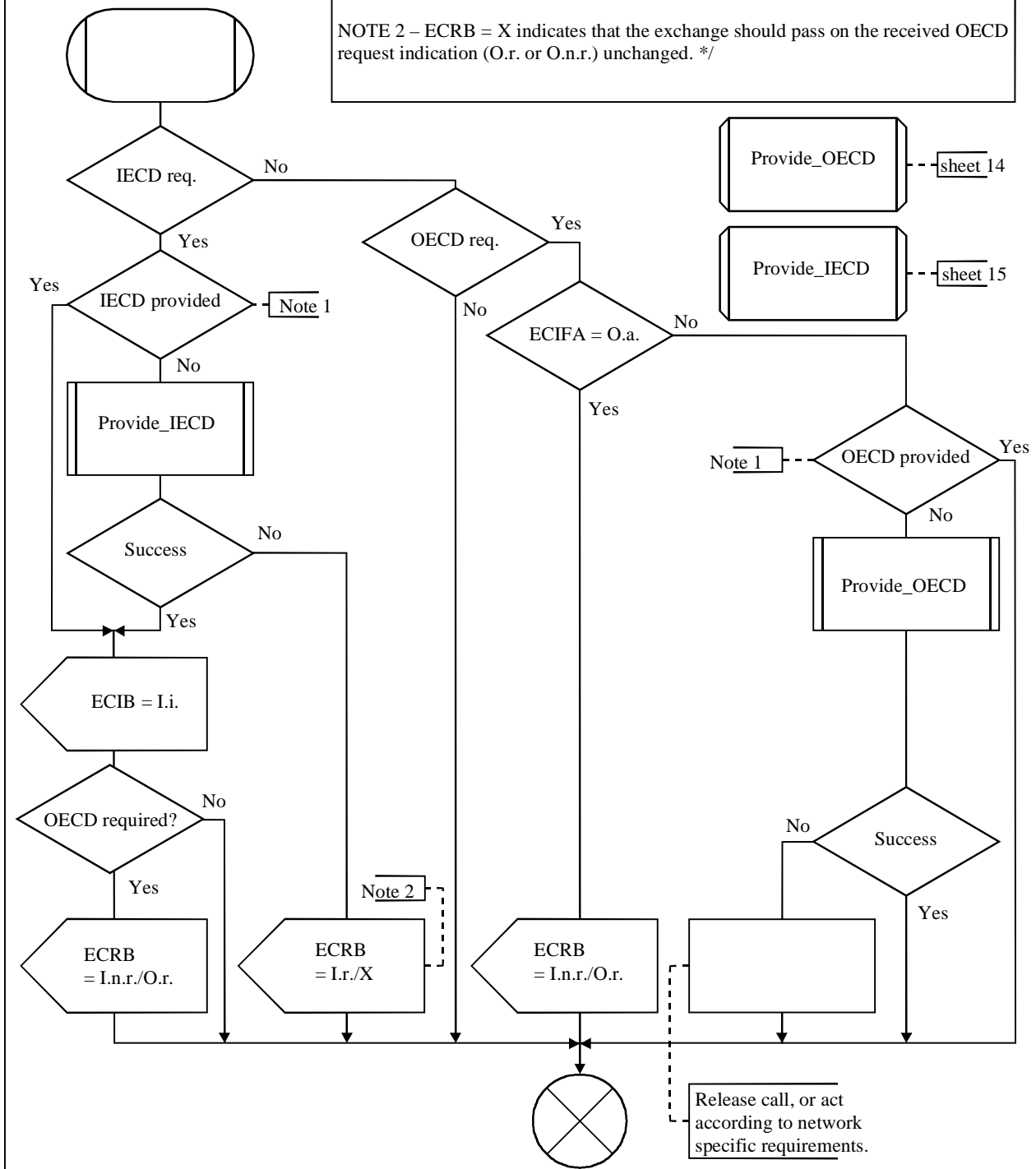
Figure A.14/Q.115 (sheet 12 of 16)



PROCEDURE ECRBp;

/\* This procedure is called to analyze ECRB indications received from the outgoing signalling system. \*/

/\* NOTE 1 – The exchange should check whether it has already provided an ECD at an earlier stage of the call. This action ensures correct operation for some supplementary services (e.g. CFNR).  
NOTE 2 – ECRB = X indicates that the exchange should pass on the received OECD request indication (O.r. or O.n.r.) unchanged. \*/

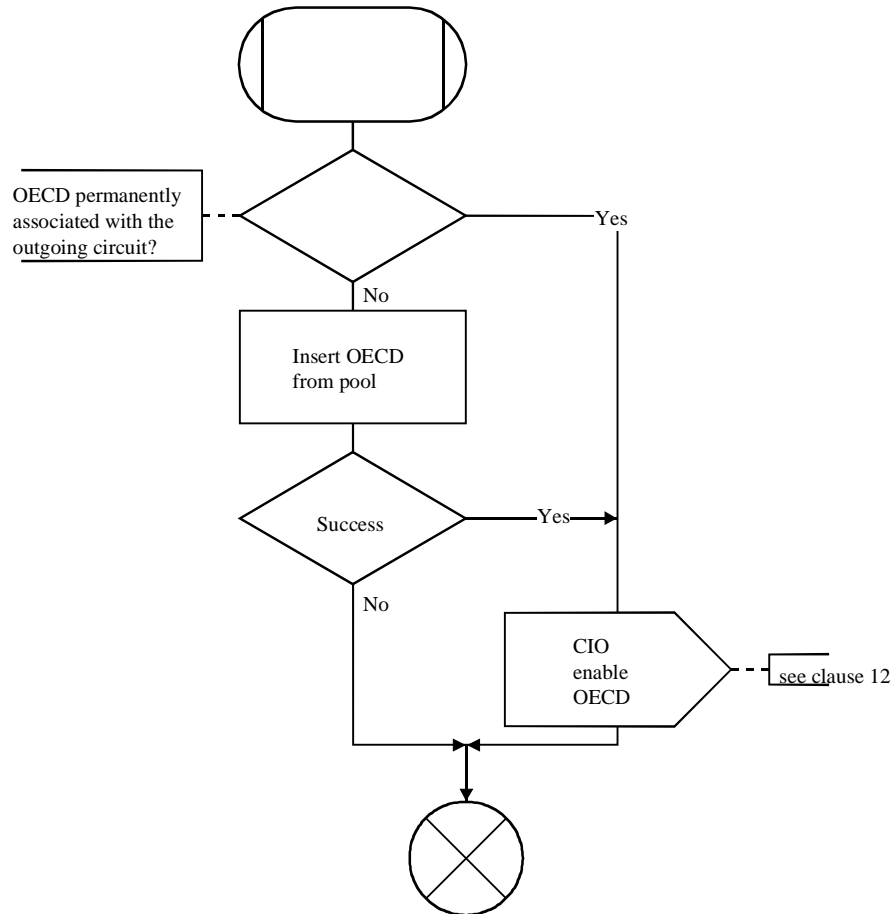


T1183600-97

Figure A.15/Q.115 (sheet 13 of 16)

PROCEDURE Provide\_OECD  
FPAR  
OUT  
BOOLEAN

/\* This procedure enables an OECD (after assigning one from a pool if required).  
It returns a value of True or False to the calling procedure indicating whether an OECD was correctly assigned. \*/

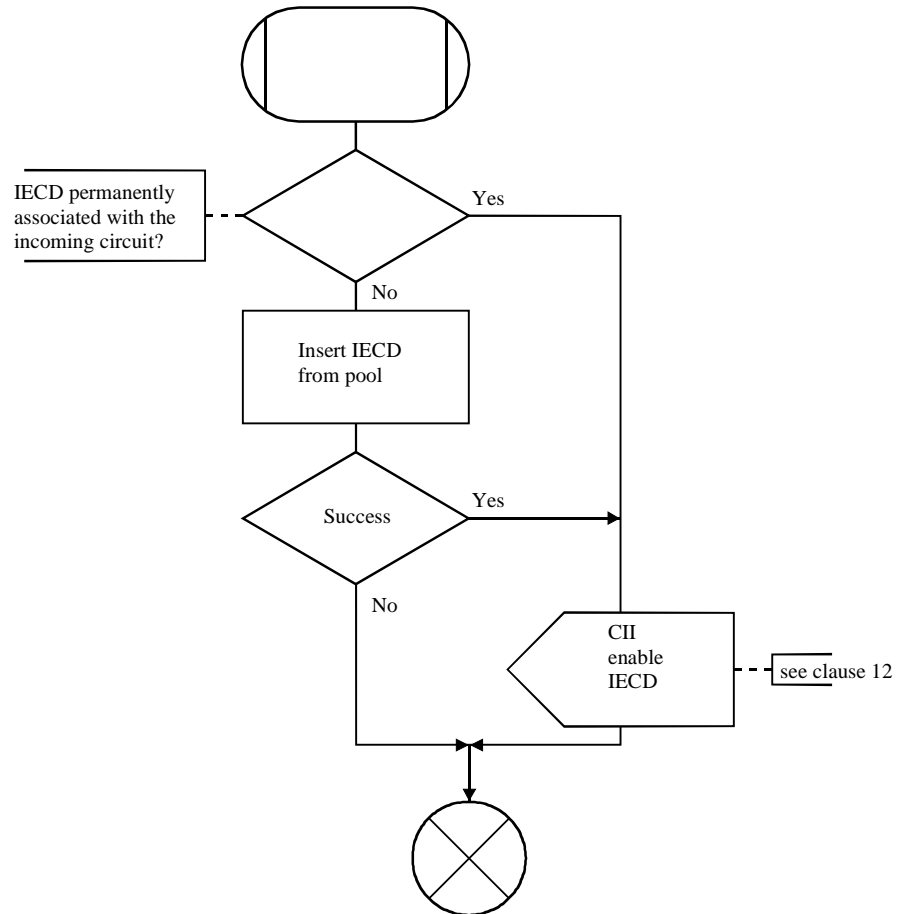


T1183610-97

Figure A.16/Q.115 (sheet 14 of 16)

PROCEDURE Provide\_IECD  
FPAR  
OUT Success BOOLEAN

/\* This procedure enables an IECD (after assigning one from a pool if required).  
It returns a value of True or False to the calling procedure indicating whether an IECD was correctly assigned. \*/



T1183620-97

Figure A.17/Q.115 (sheet 15 of 16)

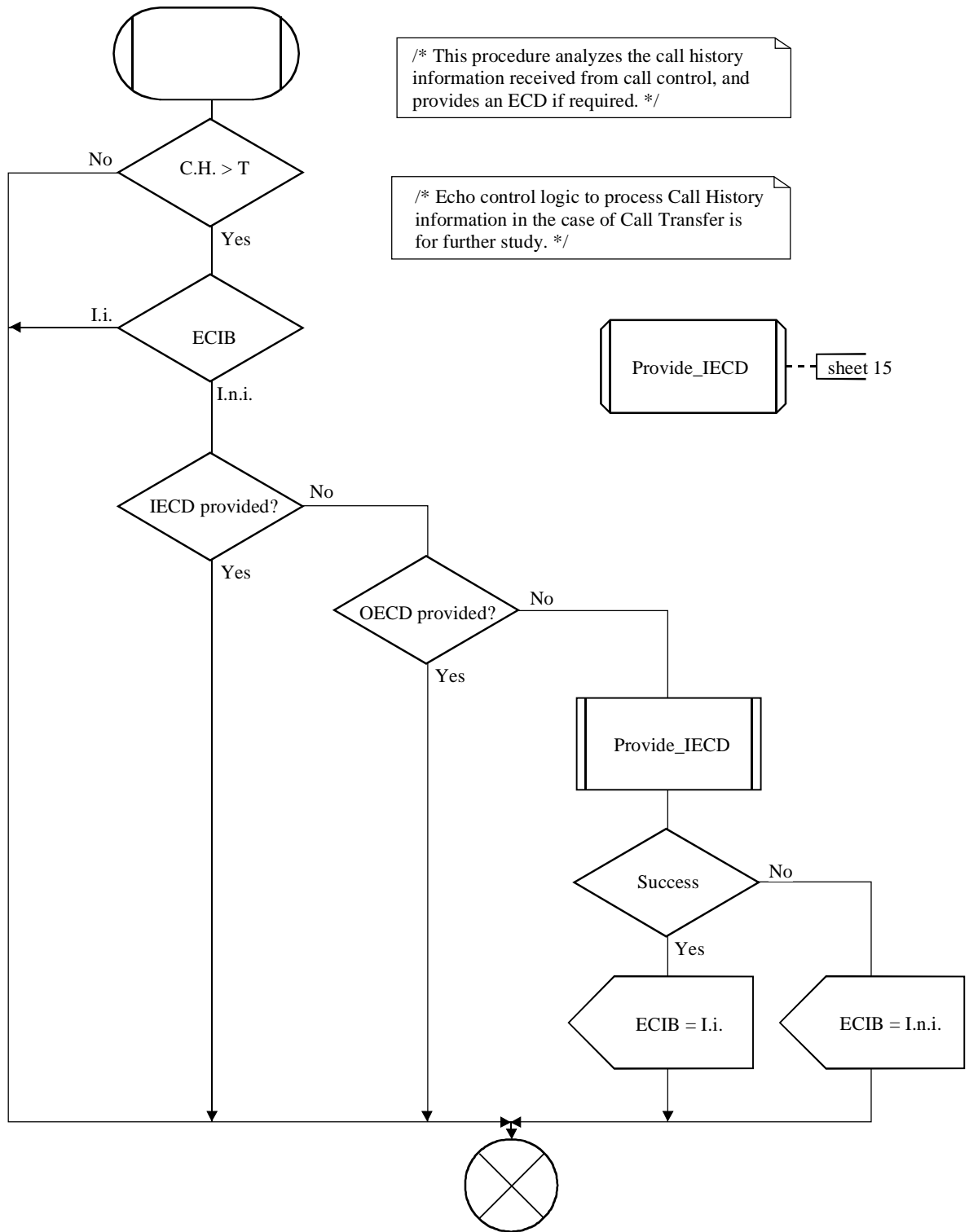


Figure A.18/Q.115 (sheet 16 of 16)

## ANNEX B

### Echo suppressor control on inter-ISC circuits within a single country

In the case where an international transit call is connected through multiple ISC's in a single country in tandem, the following problem may arise with the control of echo suppressors.

Referring to Figure B.1, which shows such a connection with two possible outgoing international circuits, one echo suppressed (exchange B), and one unsuppressed (exchange C). Exchange E does not have echo suppressors in a pool. Exchange D does not know whether or not the outgoing circuit from exchange E is provided with echo suppressors. It is not therefore able to control the half-echo suppressor HESd, since there may be an incoming half-echo suppressor later in the connection.

In order to overcome this problem, a backward signal can be used from exchange E, which informs exchange D of the provision of echo suppressors on the outgoing international circuit.

Two methods are currently proposed by Administrations to provide these backward indications, detailed below:

- i) A backward signal to exchange D indicating the presence or absence of echo suppressors on the outgoing international circuit is generated by exchange E as soon as the outgoing circuit has been selected. If a call failure situation subsequently arises and a repeat attempt is made, then a new outgoing international circuit is chosen, and a further signal is passed back to exchange D indicating the presence or absence of echo suppressors on this new circuit. HESd is then enabled, or disabled, according to the last backward echo suppressor indicator received from exchange E.
- ii) In this case HESd is initially disabled, and remains so unless a signal is received from exchange E indicating the absence of echo suppressor on the outgoing circuit. Exchange E only transmits such a signal if the outgoing international circuit has no echo suppressor provided, and will delay transmission of the signal until the address complete signal (or equivalent) is ready to be sent.

NOTE – The consideration for tandem echo control devices can be handled by the use of Signalling System No. 7 TUP or ISUP echo control signalling procedures. The consideration of echo control in the case of repeat attempts can also be handled by the same procedures.

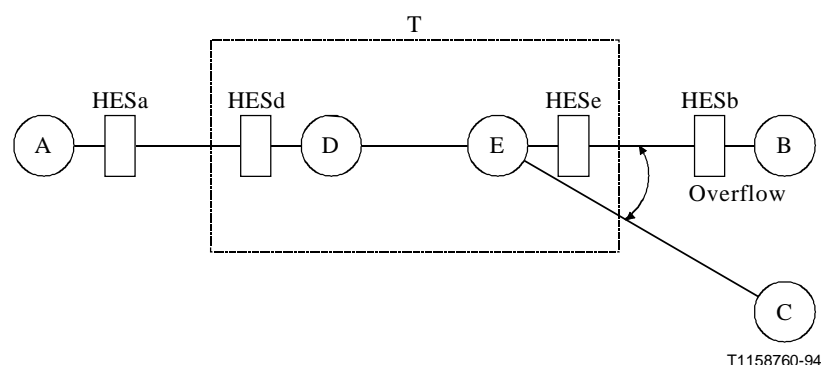


Figure B.1/Q.115 – Echo control on multiple ISC's in a country

## ANNEX C

### **Echo control for ISDN supplementary services**

This annex gives some general guidelines on the application of echo control for (ISDN) supplementary services, namely the Call Diversion, Add-on Conference and Meet Me Conference supplementary services. Echo control logic for Multi-Party and Call Transfer is for further study.

A customer may invoke some supplementary services such as Multi-Party after a call has entered the active state. The echo control logic has to assess the situation in order to re-optimize the placement of any echo control devices. To accomplish this, an exchange must retain relevant information until the call is released. This information would include:

- propagation delay value;
- bearer capability requested;
- bearer capability provided;
- whether an OECD was provided in this, or a previous exchange;
- whether an IECD was provided in this, or a subsequent exchange;
- call history value.

#### **C.1 Call diversion services**

##### **C.1.1 General**

It is assumed that each leg of a diverted call is set up applying the echo control logic described in this Recommendation.

##### **C.1.2 Use of the echo control procedures**

If there are links in the connection with a long delay, echo control devices will be included as described for the basic call.

In addition, the propagation delay time value is passed to the next link of the diverted connection, to determine when the propagation delay of the whole connection might exceed the threshold above which echo control is needed.

#### **C.2 Multi-party services**

##### **C.2.1 General**

NOTE – See also Recommendation G.172 [4] for the handling of echo in conference bridges.

Conference bridges according to Recommendation G.172 [4] should be used. In this case, an acceptable level of service can be obtained by using the echo control signalling procedures for basic call applied separately for each leg of the connection. Otherwise, the use of the additional procedures described below may be necessary. Therefore, echo control devices, once placed in a Multi-Party call, may remain active in the call regardless of disconnection of one or more legs while the remaining legs are still conversing on the call.

Optimal echo control for multi-party connections can be guaranteed if a conference bridge according to Recommendation G.172 [4] is used.

## C.2.2 Considerations

The exchange where the conference bridge is located should have the capability to invoke echo control.

Each leg of the multi-party call is set up applying echo control logic described in this Recommendation.

If a leg is set up with another signalling system, proper echo control cannot be guaranteed.

The exchange should have the capability of storing propagation delay and call history information until call release. This must be done for all legs included in the conference.

Echo control is invoked in the case that the total propagation delay for two legs in the conference is above a value  $T_{\max}$ .

$T_{\max}$  is determined:

- either by the maximum recommended value given in Recommendation G.131 [7] for connections not needing echo control; or
- in case the exchange (or conference equipment) has echo control devices, the threshold value  $T_{\max}$  is determined according to the maximum value of the echo delay the device can handle.

## C.2.3 Criteria to initiate echo control procedures

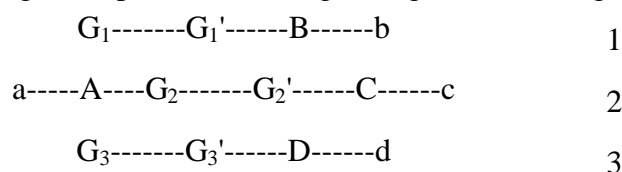
Upon adding a new call to the multi-party call, the received propagation delay value related to this leg shall be added to each of the other legs to decide whether echo control applies for the legs concerned.

In the case the exchange or the conference equipment itself has echo control equipment with sufficient capacity, invocation of echo control logic procedures may not be necessary (see C.2.1 above).

In the case it is known that echo control is already invoked on one leg of the connection, the echo control logic procedures will be initiated once more for that leg.

## C.2.4 Conference Call, Add-on, and Three-Party Service

The conference bridge is depicted in the originating local exchange A:



*Example:* Connections 1 and 2 may not alone require echo control. The total propagation delay for the two connections requires echo control. One echo control device will then be provided on each of the connections 1 and 2. IECD or OECD will be used depending on the direction of the call set-up with reference to the conference bridge. No echo control is applied on connection 3.

The echo control equipment may, in principle, be located in any of the exchanges:

- a) either in the conference bridge equipment itself;
- b) or in the exchange where the conference bridge is located;
- c) or in any of their gateway exchanges  $G_x$  or  $G_x'$ , normally being equipped with echo control devices anyway;
- d) or in any of the exchanges involved in the set up of the multi-party call.

Case a) [or b)] is to be considered as the most recommended solution, as invocation of echo control logic procedures are only necessary in the cases where the echo control devices have insufficient capability to control echo with long delays (see C.2.3).

### C.2.5 Conference Call, Meet Me

The conference bridge is depicted in the exchange D, being any type of exchange.

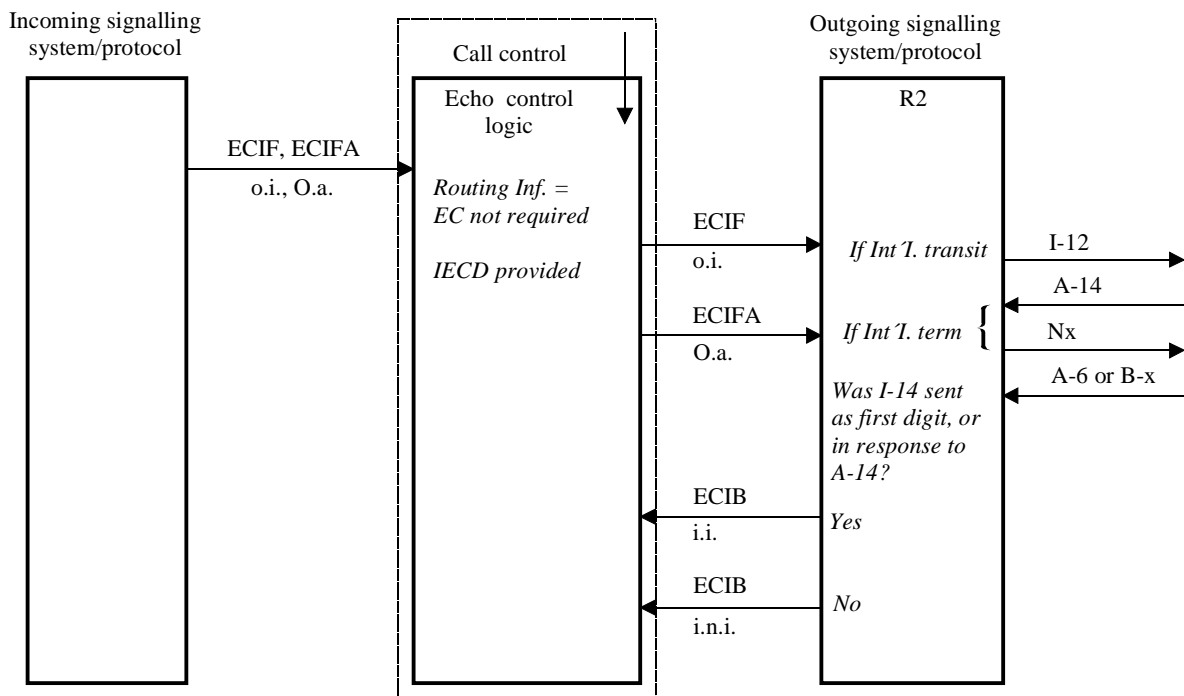
a-----A-----G<sub>1</sub>-----G<sub>1</sub>'-----D      1  
 b-----B-----G<sub>2</sub>-----G<sub>2</sub>'-----D      2  
 c-----C-----G<sub>3</sub>-----G<sub>3</sub>'-----D      3

The requirements with regard to the conference bridge equipment, handling of propagation delay information and invocation of echo control logic procedures are the same as for the Conference Call/Add-on and Three-Party Service.

## APPENDIX I

### Transmission of echo control information elements via signalling systems

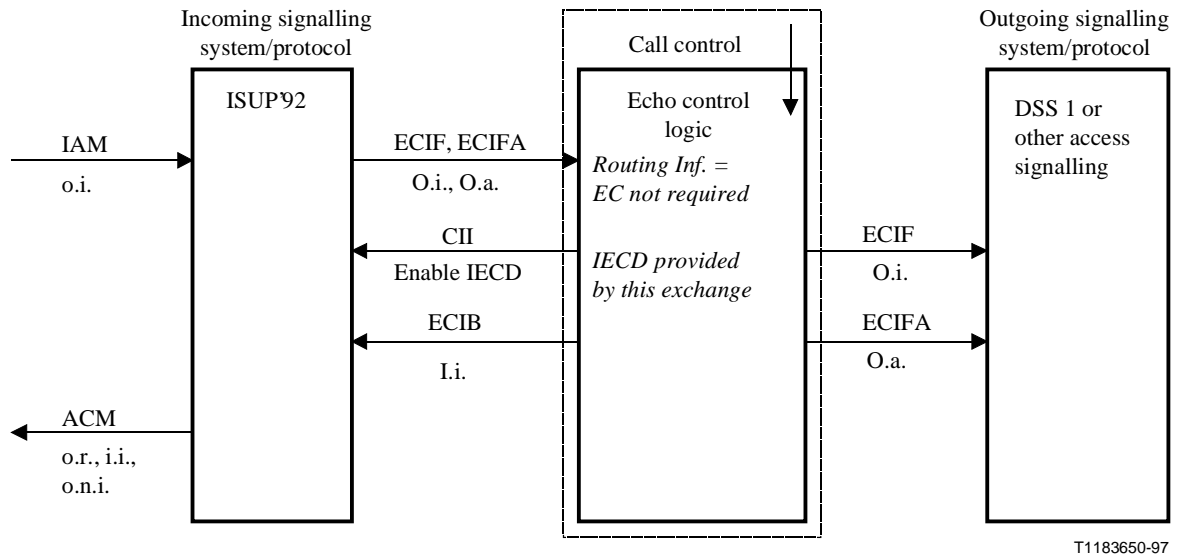
The following figures provide examples of how the exchange signalling functions interact with the echo control logic described in this Recommendation. The signalling blocks are responsible for deriving ECIFA and ECIBA information from signalling indicators or from default route data.



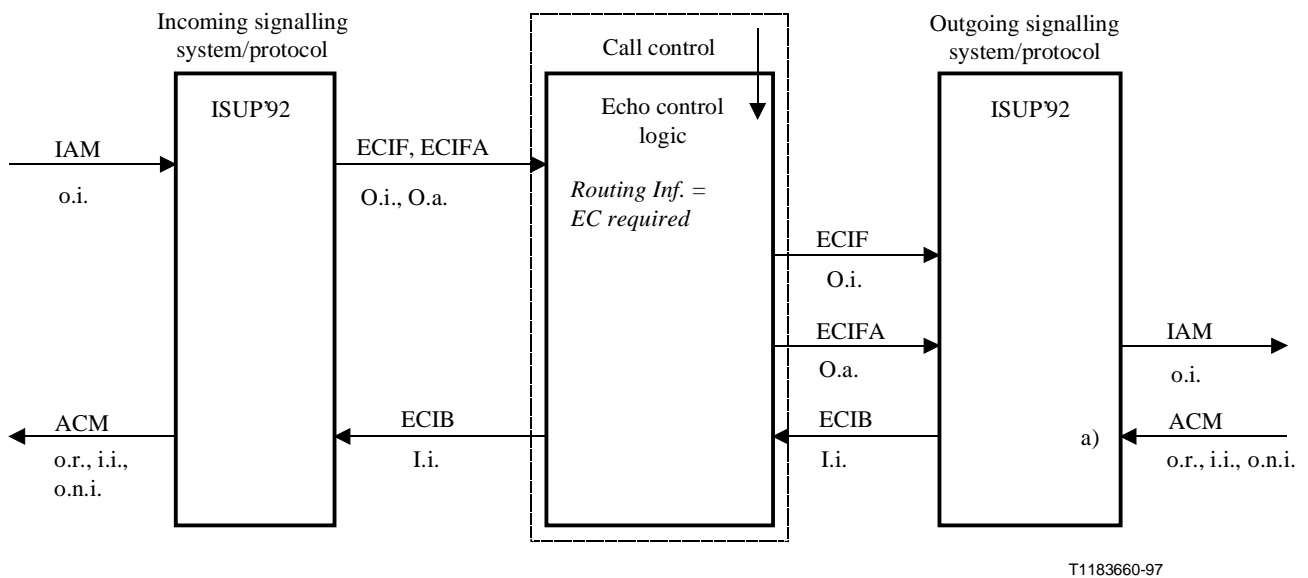
T1183640-97

Figure I.1/Q.115 – Interactions between echo control logic and CCITT R2



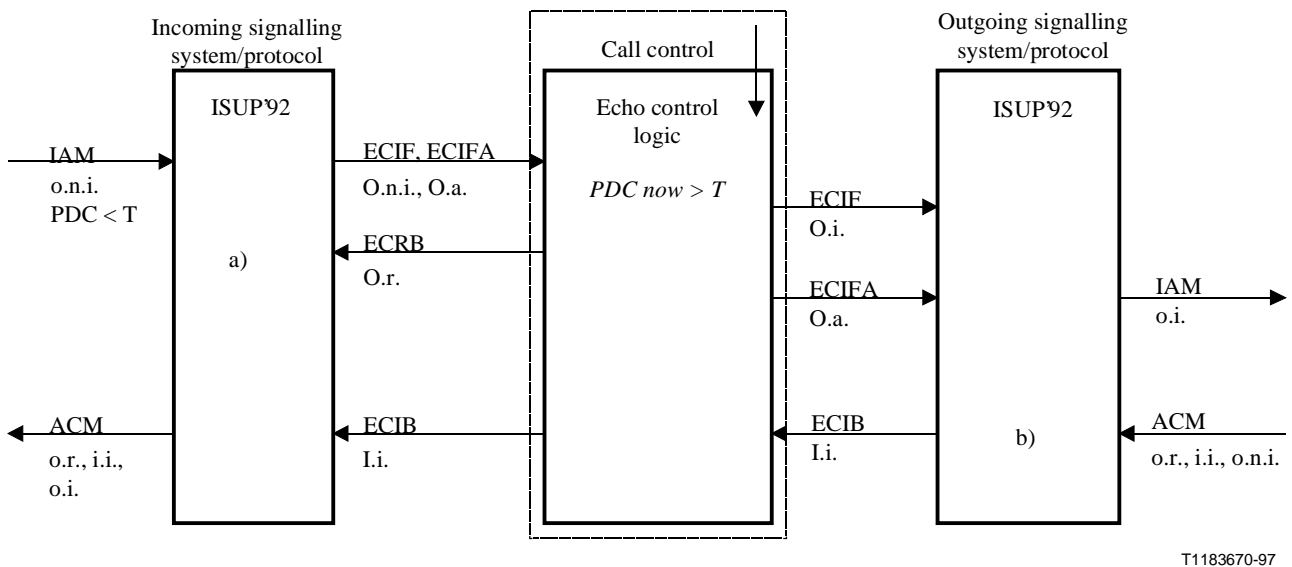


**Figure I.2/Q.115 – Interactions between echo control logic and ISUP'92**  
(refer to Exchange 6 in Figure C.1/Q.764, 1993)



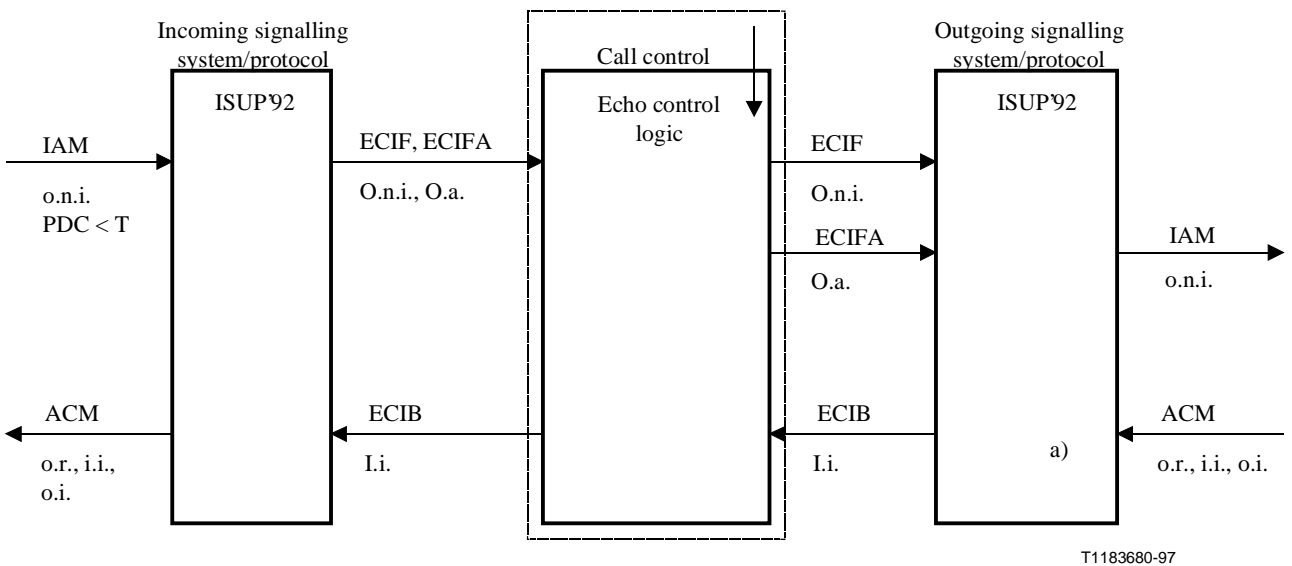
a) Do not pass the request for OECD to the echo control logic if ECIFA = O.a.

**Figure I.3/Q.115 – Interactions between echo control logic and ISUP'92**  
(refer to Exchange 5 in Figure C.1/Q.764, 1993)



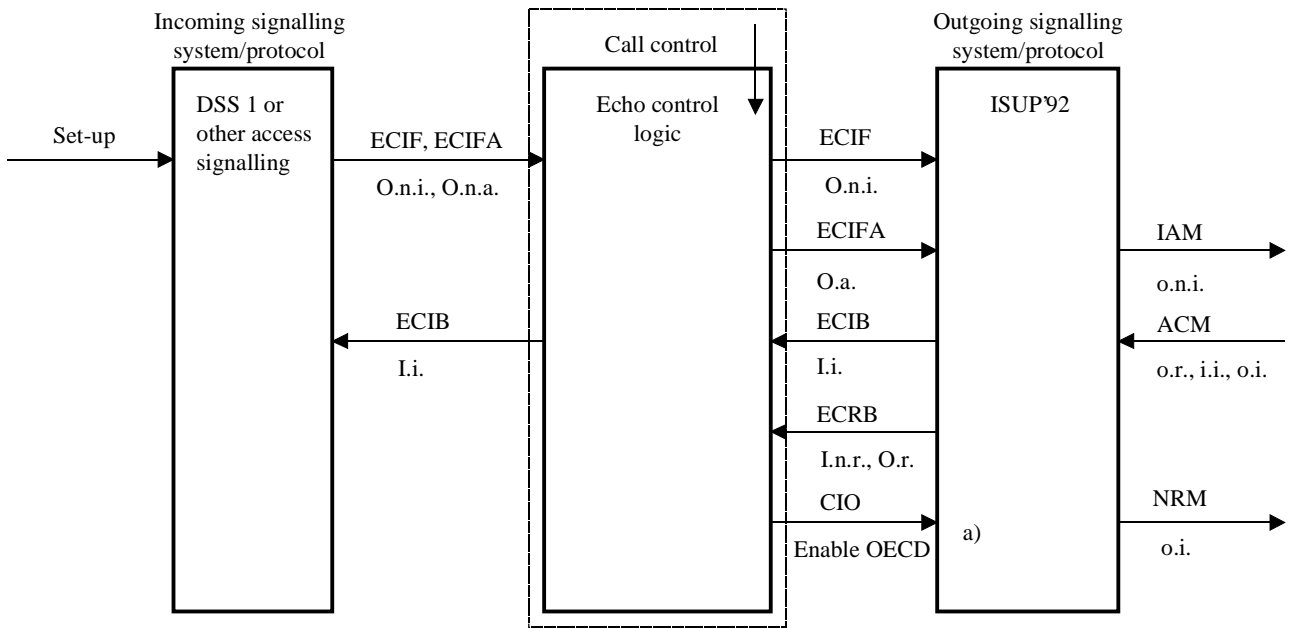
- a) Send request for OECD in first backward message.
- b) Do not pass the request for OECD to the echo control logic if ECIFA = O.a.

**Figure I.4/Q.115 – Interactions between echo control logic and ISUP'92 (refer to Exchange 4 in Figure C.1/Q.764, 1993)**



- a) Do not pass the request for OECD to the echo control logic if ECIFA = O.a.

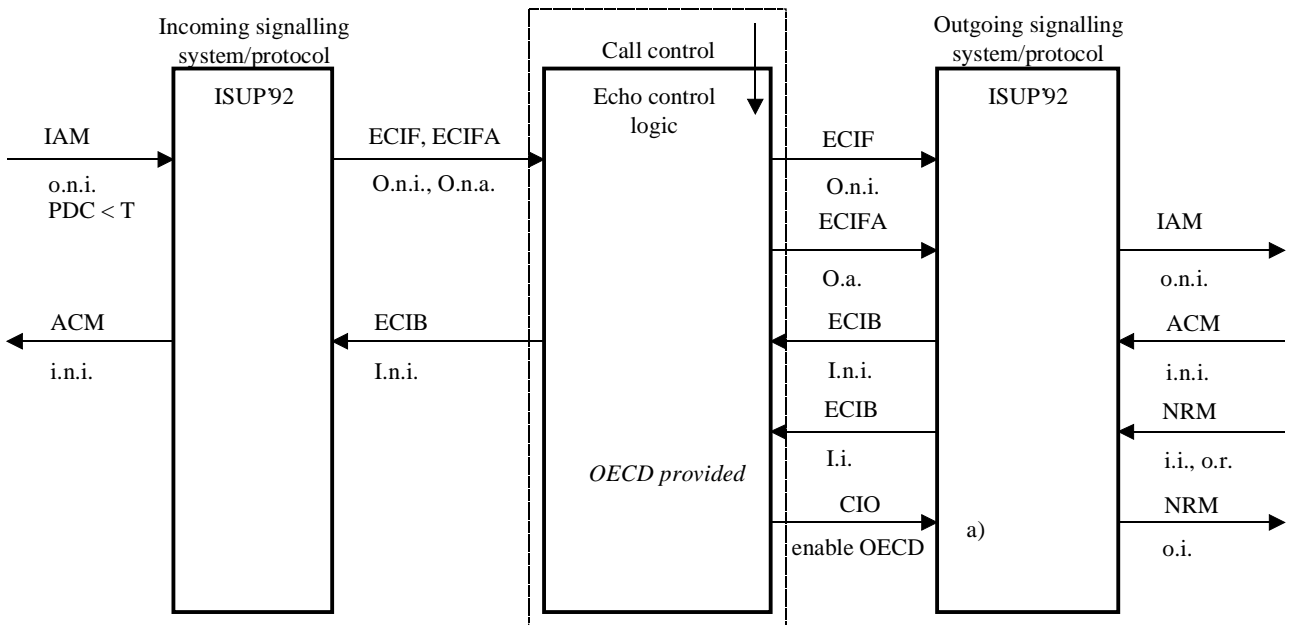
**Figure I.5/Q.115 – Interactions between echo control logic and ISUP'92 (refer to Exchanges 2 and 3 in Figure C.1/Q.764, 1993)**



T1183690-97

- a) The CIO = enable OECD information causes ISUP'92 to provide an OECD and send a forward NRM with o.i. indication to cancel T37 in succeeding ISUP'92 exchanges that do not use the echo control logic described in this Recommendation.

**Figure I.6/Q.115 – Interactions between echo control logic and ISUP'92  
(refer to Exchange 1 in Figure C.1/Q.764, 1993)**



T1183700-97

- a) The CIO = enable OECD information causes ISUP'92 to provide an OECD and send a forward NRM with o.i. indication to cancel T37 in succeeding ISUP'92 exchanges that do not use the echo control logic described in this Recommendation.

**Figure I.7/Q.115 – Interactions between echo control logic and ISUP'92  
OECD provided in response to a request after ACM**

**Table I.1/Q.115 – Echo control information/request and the corresponding signalling information elements of international signalling systems/protocols**

<b>Signalling System</b> <b>ECIF</b>	<b>CCITT R2</b>	<b>CCITT No. 5</b>	<b>TUP</b>	<b>Blue Book ISUP</b>	<b>ISUP'92</b>
No OECD in the connection	I-12 N1 (A-14)	–	IAM (OHES n.i.) GFI (OHES n.i.)	IAM (o.n.i.)	IAM/NRM (o.n.i.)
OECD in the connection	I-14 I-14 (A-14)	–	IAM (OHES i.) GFI (OHES i.)	IAM (o.i.)	IAM/NRM (o.i.)
OECD required from succ. exch.	I-11 I-14 (A-14)	–	–	–	–

<b>Signalling System</b> <b>ECIFA</b>	<b>CCITT R2</b>	<b>CCITT No. 5</b>	<b>TUP</b>	<b>Blue Book ISUP</b>	<b>ISUP'92</b>
No ECD available	–	–	–	–	–
ECD available	–	–	–	–	–

<b>Signalling System</b> <b>ECIB</b>	<b>CCITT R2</b>	<b>CCITT No. 5</b>	<b>TUP</b>	<b>Blue Book ISUP</b>	<b>ISUP'92</b>
No IECD in the connection	–	–	ACM (i.n.i.)	ACM (i.n.i.)	ACM/CPG/CON/NRM (i.n.i.)
IECD in the connection	–	–	ACM (i.i.)	ACM (i.i.)	ACM/CPG/CON/NRM (i.i.)

<b>Signalling System</b> <b>ECIBA</b>	<b>CCITT R2</b>	<b>CCITT No. 5</b>	<b>TUP</b>	<b>Blue Book ISUP</b>	<b>ISUP'92</b>
No ECD available	–	–	–	–	–
ECD available	–	–	–	–	–

<b>Signalling System</b> <b>ECRF</b>	<b>CCITT R2</b>	<b>CCITT No. 5</b>	<b>TUP</b>	<b>Blue Book ISUP</b>	<b>ISUP'92</b>
No IECD required	–	–	–	–	NRM (i.n.r.)
IECD required	–	–	–	–	NRM (i.r.)
No OECD required	–	–	–	–	NRM (o.n.r.)
OECD required	–	–	–	–	NRM (o.r.)

<b>Signalling System</b>	<b>CCITT R2</b>	<b>CCITT No. 5</b>	<b>TUP</b>	<b>Blue Book ISUP</b>	<b>ISUP'92</b>
<b>ECRB</b>					
No IECD requested	–	–	–	–	NRM (i.n.r.)
IECD requested	–	–	–	–	NRM (i.r.)
No OECD requested	–	–	–	–	ACM / NRM (o.n.r.)
OECD requested	–	–	GRQ (o.r.)	–	ACM / NRM (o.r.)

## APPENDIX II

### Echo control in B-ISDN

NOTE – These echo control logic procedures are intended for use with signalling procedures according to Recommendation Q.2764 (1995) [13].

#### II.1 Indication that echo control is needed

Echo control provided by the network can be applicable when the Narrowband Bearer Capability parameter with the value "speech" or "3.1 kHz audio" is present in the IAM message.

In addition, one or more of the following conditions should be fulfilled:

- Address digit analysis indicates that echo control is required.
- The call is routed on a virtual path for which echo control is known by data to be required.
- It is indicated by signalling that echo control is included by another exchange.
- It is indicated by signalling from another exchange that echo control is required.
- The accumulated delay as indicated by the propagation delay determination procedure exceeds the allowed value (see Recommendation G.131 [6]).

#### II.2 Fallback

When the Narrowband Bearer Capability parameter in the Initial Address message is repeated, with the value "speech" or "3.1 kHz audio" for the first repetition and "unrestricted digital information – tones/announcements" for the second repetition, this shall not affect the signalling for the echo control procedure. The echo control procedure shall run as normal based upon the value "speech" or "3.1 kHz audio" for the first repetition of the Narrowband Bearer Capability parameter, and the echo cancellers are "virtually provided" seen from the echo control procedure point of view. However, they are not actually physically provided in the transmission path until a Narrowband Bearer Capability parameter with the value "speech" or "3.1 kHz audio" has been passed in the backwards direction, and if this has not happened until after Answer, and if applicable, the echo cancellers can be released back to a pool, to be available for new calls.

#### II.3 Distribution of echo control devices in B-ISDN networks

It is assumed that echo suppressors are not used in B-ISDN exchanges, only echo cancellers. The echo control logic procedures should preferably be designed to avoid unnecessary cascading of echo control devices. However, it is assumed that the echo cancellers are implemented such that cascaded echo cancellers will only lead to an insignificant speech quality degradation.

In an originating/destination access/user terminal with large internal delay, it is assumed that both an outgoing and an incoming echo control device are always included in the access/user terminal.

In an originating access/user terminal with small internal delay, it is assumed that none or only an outgoing echo control device is included in the access/user terminal.

In a destination access/user terminal with small internal delay, it is assumed that none or only an incoming echo control device is included in the access/user terminal.

In an originating B-ISDN exchange, it is assumed that none or only an outgoing echo control device can be provided or enabled.

In a destination B-ISDN exchange, it is assumed that none or only an incoming echo control device can be provided or enabled.

It is assumed that in most intermediate B-ISDN exchanges, no echo cancellers will be available.

In some national transit B-ISDN exchanges, both outgoing and incoming echo control devices can be provided when appropriate.

In an outgoing international gateway B-ISDN exchange, it is assumed that none or only an outgoing echo control device can be provided or enabled.

In an incoming international gateway B-ISDN exchange, it is assumed that none or only an incoming echo control device can be provided or enabled.

#### **II.4 Propagation delay values**

These echo control signalling procedures are based upon the assumptions that propagation delay limits are applied in alignment with a set of principles for location of echo cancellers and echo canceller end delay requirements, which is common for both ends of the networks involved in the call, and takes the signalling procedure requirements into account. A set of such propagation delay limit values to be supported by B-ISDN networks applying these signalling procedures is described as following.

It is proposed that a propagation delay in an access/user terminal is considered to be "large" when it is more than  $2 \times 5 + 6 = 16$  ms total two-way propagation delay from the ATM switch in the local B-ISDN exchange to the acoustic user interface and back to the ATM switch in the local B-ISDN exchange (6 ms for emulation of the ATM cell format is included in the value 16 ms). In an originating/destination access/user terminal with large internal delay, it is assumed that both an outgoing and an incoming echo control device are always included in the access/user terminal.

Some radio access systems have internal propagation delays somewhat exceeding 16 ms two-way delay, but also provide some additional echo attenuation in both directions without using echo cancellers. Depending upon the specified system characteristics, such access systems could be handled from the echo control procedure point of view as ordinary accesses with low internal delay and without internal echo cancellers.

NOTE – An example of such a system is a radio access according to "DECT" specifications.

If correct data for the propagation delay and some other G.131 [6] parameters in the access and user terminals are not available in the exchange, it is proposed that a default value of 10 ms (one way) for the originating access and 0 ms for the destination access is used generally for all accesses by the signalling procedures in the exchange. The ATM format emulation delay (6 ms) is assumed to be included in these values.

The allowed accumulated propagation delay value without echo cancellers according to Recommendation G.131 [6] depends on several parameter values, which could be different for each call and are not necessarily known in the exchange.

If sufficient data is not available to determine the correct total allowed accumulated one way propagation delay value according to Recommendation G.131 [6], it is proposed that a default limit of 16 ms is used, i.e. echo cancellers should be used if one way accumulated propagation delay exceeds this limit.

Examples when default limit value 16 ms is used:

- 7 ms in the originating access + 8 ms in the network from the originating to destination access + 0 ms in the destination access = total 15 ms  $\Rightarrow$  echo control is not required.
- 10 ms in the originating access + 12 ms in the network from the originating to destination access + 0 ms in the destination access = total 22 ms  $\Rightarrow$  echo control is required.

## II.5 End delay requirements

End delay requirements for echo cancellers should take into account actual end delays both in the network and the access, including possible radio access systems with large delays. End delay requirements must be aligned with the location of echo cancellers within the network.

Examples:

Maximum 13 ms one-way propagation delay from local exchange to intermediate exchange with echo cancellers. The requirement is valid for echo cancellers in intermediate B-ISDN exchanges, echo cancellers in accesses/user terminals with "large" internal delays, echo cancellers in gateways of digital mobile networks interworking with B-ISDN:

$$28 + 6 + (2 \times 13) = 60 \text{ ms end delay}$$

28 ms = two-way delay in radio access system,

6 ms = ATM format emulation delay,

$2 \times 13$  ms = two-way propagation delay from local exchange to intermediate exchange with echo cancellers.

Echo canceller in local B-ISDN exchange, radio access with additional delay attached to the exchange:

$$28 + 6 = 34 \text{ ms end delay}$$

28 ms = maximum permitted two-way delay in radio access system without built-in echo cancellers,

6 ms = ATM format emulation delay.

Echo canceller in local B-ISDN exchange, no radio access with additional delay attached to the exchange:

$$16 \text{ ms end delay}$$

16 ms = limit for two-way propagation for an access without built-in echo cancellers.

## II.6 Quality of service management

If echo control devices are required within the B-ISDN network, but none is available, the call may continue. However, then the user in some cases will experience degradation of transmission quality.

For this reason there is a need to detect that there is a possible quality of service degradation. The management system shall be notified that a performance degradation event has occurred for this call, to be registered by the performance management system.

The principle of "failure of last opportunity" should be used. If the relevant echo cancellers for the call are located in the local B-ISDN exchange, then the registration of performance degradation

should be done in the local B-ISDN exchange. If echo cancellers relevant for the call also can be inserted in an intermediate B-ISDN exchange within the appropriate round-trip delay range of the echo cancellers, then the registration of performance degradation should be done in this intermediate exchange.



## ITU-T RECOMMENDATIONS SERIES

- Series A Organization of the work of the ITU-T
- Series B Means of expression: definitions, symbols, classification
- Series C General telecommunication statistics
- Series D General tariff principles
- Series E Overall network operation, telephone service, service operation and human factors
- Series F Non-telephone telecommunication services
- Series G Transmission systems and media, digital systems and networks
- Series H Audiovisual and multimedia systems
- Series I Integrated services digital network
- Series J Transmission of television, sound programme and other multimedia signals
- Series K Protection against interference
- Series L Construction, installation and protection of cables and other elements of outside plant
- Series M TMN and network maintenance: international transmission systems, telephone circuits, telegraphy, facsimile and leased circuits
- Series N Maintenance: international sound programme and television transmission circuits
- Series O Specifications of measuring equipment
- Series P Telephone transmission quality, telephone installations, local line networks
- Series Q Switching and signalling**
- Series R Telegraph transmission
- Series S Telegraph services terminal equipment
- Series T Terminals for telematic services
- Series U Telegraph switching
- Series V Data communication over the telephone network
- Series X Data networks and open system communication
- Series Z Programming languages