



INTERNATIONAL TELECOMMUNICATION UNION

ITU-T

TELECOMMUNICATION
STANDARDIZATION SECTOR
OF ITU

O.191

(04/97)

SERIES O: SPECIFICATIONS OF MEASURING
EQUIPMENT

Equipment for the measurement of digital and
analogue/digital parameters

**Equipment to assess ATM layer cell transfer
performance**

ITU-T Recommendation O.191

(Previously CCITT Recommendation)

ITU-T O-SERIES RECOMMENDATIONS
SPECIFICATIONS OF MEASURING EQUIPMENT

General	O.1–O.9
Maintenance access	O.10–O.19
Automatic and semi-automatic measuring systems	O.20–O.39
Equipment for the measurement of analogue parameters	O.40–O.129
Equipment for the measurement of digital and analogue/digital parameters	O.130–O.199

For further details, please refer to ITU-T List of Recommendations.

ITU-T RECOMMENDATION O.191

EQUIPMENT TO ASSESS ATM LAYER CELL TRANSFER PERFORMANCE

Source

ITU-T Recommendation O.191 was prepared by ITU-T Study Group 4 (1993-1996) and was approved under the WTSC Resolution No. 1 procedure on the 19th of April 1997.

FOREWORD

ITU (International Telecommunication Union) is the United Nations Specialized Agency in the field of telecommunications. The ITU Telecommunication Standardization Sector (ITU-T) is a permanent organ of the ITU. The ITU-T is responsible for studying technical, operating and tariff questions and issuing Recommendations on them with a view to standardizing telecommunications on a worldwide basis.

The World Telecommunication Standardization Conference (WTSC), which meets every four years, establishes the topics for study by the ITU-T Study Groups which, in their turn, produce Recommendations on these topics.

The approval of Recommendations by the Members of the ITU-T is covered by the procedure laid down in WTSC Resolution No. 1.

In some areas of information technology which fall within ITU-T's purview, the necessary standards are prepared on a collaborative basis with ISO and IEC.

NOTE

In this Recommendation, the expression "Administration" is used for conciseness to indicate both a telecommunication administration and a recognized operating agency.

INTELLECTUAL PROPERTY RIGHTS

The ITU draws attention to the possibility that the practice or implementation of this Recommendation may involve the use of a claimed Intellectual Property Right. The ITU takes no position concerning the evidence, validity or applicability of claimed Intellectual Property Rights, whether asserted by ITU members or others outside of the Recommendation development process.

As of the date of approval of this Recommendation, the ITU had/had not received notice of intellectual property, protected by patents, which may be required to implement this Recommendation. However, implementors are cautioned that this may not represent the latest information and are therefore strongly urged to consult the TSB patent database.

© ITU 1997

All rights reserved. No part of this publication may be reproduced or utilized in any form or by any means, electronic or mechanical, including photocopying and microfilm, without permission in writing from the ITU.

CONTENTS

	Page
1	Scope..... 1
2	References..... 1
3	Definitions 3
4	Abbreviations..... 3
5	Measurement of network performance parameters..... 4
5.1	Measurement point location and measurement process..... 4
5.2	ATM reference events, outcomes and network performance parameters..... 5
5.2.1	ATM reference events 5
5.2.2	ATM outcomes and defects..... 5
5.2.3	ATM network performance parameters..... 6
5.2.4	Other useful network parameters..... 7
5.3	Physical layer reference events and outcomes..... 8
6	Measurement modes 8
7	Out-of-service measurement mode..... 8
7.1	Generation of traffic at the ATM layer level 8
7.1.1	Test traffic..... 8
7.2	Background traffic 11
7.3	Other generation functions..... 12
7.3.1	Generation of OAM cell streams..... 12
7.3.2	Generation of outcomes..... 12
7.4	ATM cell transfer outcomes determination 12
7.5	Network performance parameters calculation 13
7.5.1	Error-related network performance parameters..... 13
7.5.2	Availability related network performance parameters..... 14
7.5.3	Delay-related network performance parameters..... 14
7.6	Other receiver functions..... 14
8	In-service measurement mode 14
8.1	Error-related network performance parameters..... 14
8.1.1	General considerations..... 14
8.1.2	Monitored cell flows..... 16
8.1.3	ATM outcomes determination..... 20
8.1.4	Parameters calculation..... 20

	Page	
8.2	Availability-related network performance parameters.....	20
8.2.1	General considerations.....	20
8.2.2	Monitored cell flows.....	20
8.3	Delay-related network performance parameters.....	20
8.3.1	General considerations.....	20
8.3.2	Monitored cell flows.....	20
8.3.3	Measurement method	21
9	Physical interfaces of the ATM measuring equipment.....	21
9.1	General interface characteristics and bit rates.....	21
9.2	Interface characteristics – Generator part	22
9.2.1	Synchronization of the generator part.....	23
9.3	Interface characteristics – Receiver part.....	23
9.3.1	Information available at physical interfaces.....	23
10	Miscellaneous functions	23
10.1	Display	24
10.2	Anomaly and defect simulation on the output signal.....	24
10.3	Alarm and error indication.....	24
10.4	Event time stamping	24
10.5	Output to external recording devices	24
10.6	Remote control port	24
10.7	TMN interface.....	24
11	Operating conditions.....	24
11.1	Environmental conditions	24
11.2	Behaviour in case of power failure.....	24
	Annex A – Criteria for the detection of anomalies, defects and indications.....	25
	Annex B – Measurement algorithms.....	26
B.1	Basic out-of-service cell transfer outcome measurement algorithm.....	26
	Annex C – Test cell payload scrambling/descrambling.....	28
C.1	Scrambling/descrambling	28
C.2	Scrambling and CRC	28

	Page
Appendix I – Examples of use of the different measuring modes	29
I.1 Use of the out-of-service measurement mode.....	29
I.2 Use of the in-service measurement mode	30
I.2.1 End-to-end test.....	30
I.2.2 Segment test.....	30
I.2.3 UPC/NPC testing.....	30
I.3 Combined use of out-of-service and in-service measurement modes.....	31

Preamble

The requirements for the characteristics of the ATM Measuring Equipment (AME) described in this Recommendation must be adhered to in order to ensure that the following objectives are met:

- **Compatibility between test equipment produced by different manufacturers:** Any generation of ATM cells by the AME should be equivalent given the same control settings on different test equipment. Any analysis of ATM cell performance by the AME should provide the same results as different test equipment when provided with the same cell stream(s).
- **Compatibility between test equipment and network equipment:** Any in-service measurement by the AME of network performance parameters and defects defined in Recommendations I.356 and I.610 should provide the same results as network equipment monitoring when provided with the same cell stream(s).
- **Compatibility between out-of-service and in-service measurements:** Any out-of-service analysis by the AME of performance parameters and defects defined in Recommendations I.356 and I.610 should provide higher quality results (in terms of accuracy and robustness) than in-service monitoring when applied to the equivalent network connection(s).

While requirements are given for the AME, the realization of the equipment configuration is not covered and should be given careful consideration by the designer and user. In particular, it is not required that all features listed below shall be provided in one piece of measuring equipment. Users may select those functions which correspond best to their applications.

Recommendation O.191

EQUIPMENT TO ASSESS ATM LAYER CELL TRANSFER PERFORMANCE

1 Scope

This Recommendation describes the functions which an equipment assessing ATM layer cell transfer performance should fulfil. This includes evaluation of the physical layer (with the transmission convergence sublayer). For the time being, the specification of AAL performance measurement functions is not addressed in this Recommendation.

Recommendation I.356 [1] specifies cell transfer outcomes and associated network performance parameters which characterize the performance of ATM layer cell transfer performance. The present version of Recommendation I.356 handles either VP or VC connections for which the only specified traffic parameter is the peak cell rate. Recommendation I.356 may be augmented or modified when other traffic parameters are introduced. Therefore, this Recommendation will be enhanced in the future to accommodate the evolution of Recommendation I.356.

Availability decisions and associated availability parameters are specified in Recommendation I.357 [2]. This Recommendation only considers semi-permanent VP or VC connections. It is expected that the set of network performance parameters shall be augmented in order to take account of switched VP or VC connections.

Network performance parameters can be monitored by OAM cell streams which are specified in Recommendation I.610 [3].

Functions defined in this Recommendation enable:

- any AME to analyze information provided by another AME conforming to this Recommendation or by the OAM flows provided by the network elements;
- any two AMEs conforming to this Recommendation to provide the same means to analyze the performance parameters of a given ATM connection or connection segment.

2 References

The following ITU-T Recommendations and other references contain provision which, through reference in this text, constitute provisions of this Recommendation. At the time of publication, the editions indicated were valid. All Recommendations and other references are subject to revision; all users of this Recommendation are therefore encouraged to investigate the possibility of applying the most recent edition of the Recommendations and other references listed below. A list of the currently valid ITU-T Recommendations is regularly published.

- [1] ITU-T Recommendation I.356 (1996), *B-ISDN ATM layer cell transfer performance*.
- [2] ITU-T Recommendation I.357 (1996), *B-ISDN semi-permanent connection availability*.
- [3] ITU-T Recommendation I.610 (1995), *B-ISDN operation and maintenance principles and functions*.
- [4] ITU-T Recommendation I.353 (1996), *Reference events for defining ISDN and B-ISDN performance parameters*.
- [5] ITU-T Recommendation I.371 (1996), *Traffic control and congestion control in B-ISDN*.
- [6] ITU-T Recommendation I.361 (1995), *B-ISDN ATM layer specification*.

- [7] CCITT Recommendation G.703 (1991), *Physical/electrical characteristics of hierarchical digital interfaces.*
- [8] ITU-T Recommendation G.704 (1995), *Synchronous frame structures used at 1544, 6312, 2048, 8488 and 44 736 kbit/s hierarchical levels.*
- [9] ITU-T Recommendation G.707 (1996), *Network node interface for the Synchronous Digital Hierarchy (SDH).*
- [10] ITU-T Recommendation G.957 (1995), *Optical interfaces for equipments and systems relating to the synchronous digital hierarchy.*
- [11] ITU-T Recommendation G.772 (1993), *Protected monitoring points provided on digital transmission systems.*
- [12] ITU-T Recommendation G.823 (1993), *The control of jitter and wander within digital networks which are based on the 2048 kbit/s hierarchy.*
- [13] ITU-T Recommendation G.824 (1993), *The control of jitter and wander within digital networks which are based on the 1544 kbit/s hierarchy.*
- [14] ITU-T Recommendation G.825 (1993), *The control of jitter and wander within digital networks which are based on the Synchronous Digital Hierarchy (SDH).*
- [15] ITU-T Recommendation I.432.2 (1996), *B-ISDN user-network interface – Physical layer specification: 155 520 kbit/s and 622 080 kbit/s operation.*
- [16] ITU-T Recommendation I.432.3 (1996), *B-ISDN user-network interface – Physical layer specification: 1544 kbit/s and 2048 kbit/s operation.*
- [17] ITU-T Recommendation I.432.4 (1996), *B-ISDN user-network interface – Physical layer specification: 51 840 kbit/s operation.*
- [18] ITU-T Recommendation I.432.5 (1997), *B-ISDN user-network interface – Physical layer specification: 25 600 kbit/s operation.*
- [19] ITU-T Recommendation G.804 (1993), *ATM cell mapping into Plesiochronous Digital Hierarchy (PDH).*
- [20] ITU-T Recommendation G.832 (1995), *Transport of SDH elements on PDH networks – Frame and multiplexing structures.*
- [21] CCITT Recommendation O.3 (1992), *Climatic conditions and relevant tests for measuring equipment.*
- [22] ITU-T Recommendation V.24 (1996), *List of definitions for interchange circuits between Data Terminal Equipment (DTE) and Data Circuit-terminating Equipment (DCE).*
- [23] ITU-T Recommendation V.28 (1993), *Electrical characteristics for unbalanced double-current interchange circuits.*
- [24] ITU-T Recommendation X.25 (1996), *Interface between Data Terminal Equipment (DTE) and Data Circuit-terminating Equipment (DCE) for terminals operating in the packet mode and connected to public data networks by dedicated circuit.*
- [25] IEC Publication 625 – An interface system for programmable measuring instruments (byte serial, bit parallel).
- [26] IEEE Standard 488 – IEEE standard digital interface for programmable instrumentation.

3 Definitions

This Recommendation defines the following terms:

- 3.1 **user cell:** See 8.1.2.
- 3.2 **error-related network performance parameters:** See 5.2.3.
- 3.3 **delay-related network performance parameters:** See 5.2.3.
- 3.4 **availability-related network performance parameters:** See 5.2.3.

4 Abbreviations

This Recommendation uses the following abbreviations:

AIS	Alarm Indication Signal
AME	ATM Measuring Equipment
AR	Availability Ratio
ATM	Asynchronous Transfer Mode
CDV	Cell Delay Variation
CER	Cell Error Ratio
CLP	Cell Loss Priority
CLR	Cell Loss Ratio
CMR	Cell Misinsertion Rate
CRC	Cyclic Redundancy Check
CTD	Cell Transfer Delay
EDC	Error Detecting Code
FM	Forward monitoring
Fx PM flow	F4 or F5 Performance Management flow as appropriate
LBRF	Loss of Backward Reporting Flow
LFMF	Loss of Forward Monitoring Flow
LOC	Loss Of Continuity
LPAC	Loss of Performance Assessment Capability
LSB	Least Significant Bit
MP	Measurement Point
MSB	Most Significant Bit
MTBO	Mean Time Between Outages
NPP	Network Performance Parameters
OAM	Operation, Administration and Maintenance
OOS	Out-Of-Service
PCR	Peak Cell Rate
PM	Performance Management

PPI	Proprietary Payload Indicator
RDI	Remote Defect Indication
SECBR	Severely Errored Cell Block Ratio
SES _{ATM}	Severely Errored Second at the ATM layer
SN	Sequence Number
TCPT	Test Cell Payload Type
TS	Time Stamp
VC	Virtual Channel
VP	Virtual Path
V _X -AIS	VP-AIS or VC-AIS as appropriate
V _X -LOC	VP-LOC or VC-LOC as appropriate
V _X -RDI	VP-RDI or VC-RDI as appropriate

5 Measurement of network performance parameters

5.1 Measurement point location and measurement process

The functional location of the ATM measurement points where the ATM layer cell transfer performance shall be assessed is defined in Recommendation I.353 [4]. The measurement point for a VP connection is located at the interface between the VP multiplexing/demultiplexing function and other VP functions. Similarly, the measurement point for a VC connection is located at the interface between the VC multiplexing/demultiplexing function and other VC functions.

Since these functional interfaces are generally not accessible to measuring equipment, practical ATM measurements can be performed with the AME connected at the physical interface, the AME being connected as near as possible to the functional measurement point. This implies that the time of occurrences of reference events can only be approximated by the AME and that it shall emulate the physical layer functions. Therefore, this Recommendation specifies not only functions related to the ATM layer but also functions related to the physical layer in order to discriminate between proper ATM network performance parameters and misbehaviour of the AME at the physical level.

Network performance parameters are derived from the observation of different events occurring at one or more measurement points throughout the network. Events are processed in two steps: The sequence of monitored events is analyzed to determine outcomes and defects, then outcomes and defects are further processed to compute finally the set of network performance parameters.

This general measurement process is illustrated in Figure 5-1.

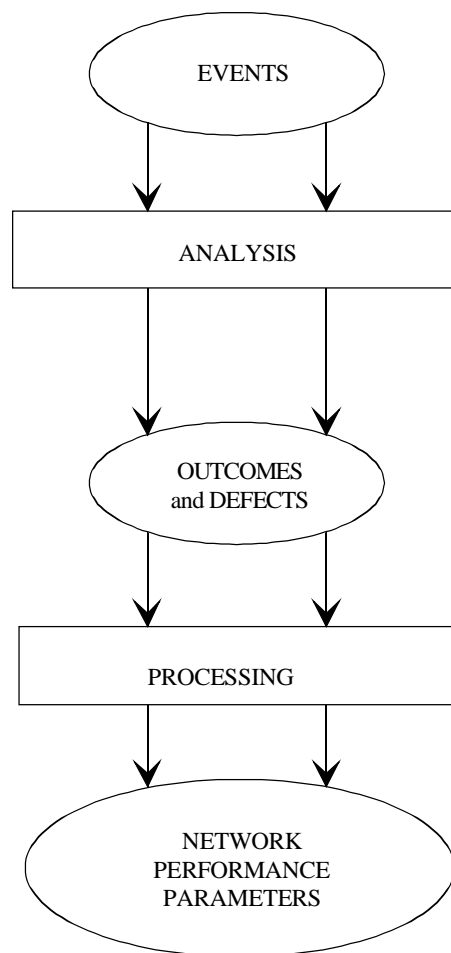

T0406850-96

Figure 5-1/O.191 – General measurement process

5.2 ATM reference events, outcomes and network performance parameters

5.2.1 ATM reference events

The two basic ATM reference events specified in Recommendation I.356 are:

- Cell exit event;
- Cell entry event.

5.2.2 ATM outcomes and defects

The following cell transfer outcomes are defined in Recommendations I.356 or I.357:

- Successfully transferred cell;
- Errored cell;
- Lost cell;
- Misinserted cell;
- Tagged cell;
- Severely Errored Cell Block;
- Severely Errored Second.

Defects detected at the ATM layer are to be monitored for the purpose of network performance parameters determination. Among those, the following are defined in Recommendation I.610:

- VP-AIS;
- VP-LOC;
- VP-RDI;
- VC-AIS;
- VC-LOC;
- VC-RDI.

5.2.3 ATM network performance parameters

The AME shall compute the following performance parameters defined in Recommendations I.356 and I.357:

- 1) *Error-related network performance parameters*
 - Cell Error Ratio;
 - Cell Loss Ratio;
 - Severely Errored Cell Block Ratio;
 - Cell Misinsertion Rate.
- 2) *Availability-related network performance parameters*
 - Availability Ratio;
 - Mean Time Between Outages.
- 3) *Delay-related performance parameters*
 - Mean Cell Transfer Delay;
 - Cell Delay Variation (1 point and 2 points).

While a connection or a connection portion is under measurement, ATM events related to that connection shall be monitored and ATM outcomes shall be determined permanently independently of the availability status of the connection. The error- and delay-related network performance parameters listed above shall only be computed when the ATM connection under test is in the available state as defined in Recommendation I.356. Figure 5-2 shows the basic relationships between ATM layer outcomes, ATM layer defects and severely errored cell blocks and how the measurement of these parameters is controlled by the availability status of the ATM connection.

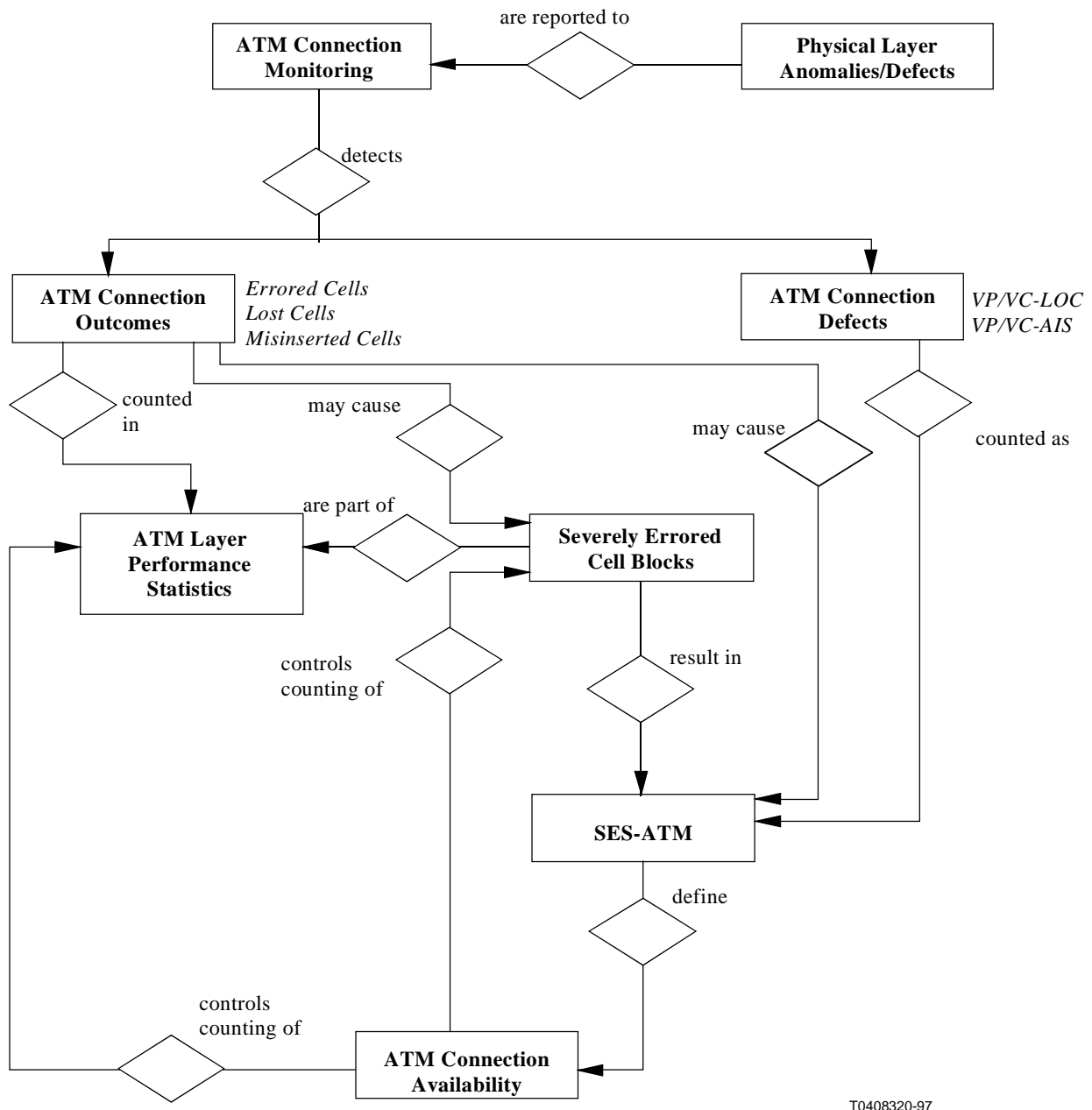

Figure 5-2/O.191 – Relationships between availability and ATM outcomes and defects

NOTE – Figure 5-2 applies only to a unidirectional ATM connection. Details of the relationships for a bidirectional connection require further study.

5.2.4 Other useful network parameters

In addition, the AME may compute the number of non-conforming cells as defined in Recommendations I.356 and I.371.

The decision to declare a cell conforming or non-conforming is based upon the arrival time of the cell as defined in Recommendation I.371.

5.3 Physical layer reference events and outcomes

NOTE – This subclause should provide a list of events and outcomes related to the physical layer which shall be detected and processed for validating ATM-NPP evaluation or which may provide useful information while performing this evaluation. Defects and anomalies of the transmission convergence sublayer such as out-of-cell delineation and loss-of-cell delineation may be included here. This requires further study.

6 Measurement modes

Two measurement modes have been identified:

- 1) *Out-of-service measurement mode* – In this mode, after having set up a connection dedicated to the measurement of cell transfer performance, appropriate test cell sequences are transmitted on this connection and are analyzed at the receive side.
- 2) *In-service measurement mode* – In this mode, generally the contents of OAM cells which are either provided by the end user equipment or by a network element is analyzed, and the data derived from these contents are compared with corresponding data computed directly on the user cell stream.

Measurement modes 1 and 2 can be used simultaneously. It is possible to use the in-service measurement mode on a test connection which has been set up in order to perform out-of-service measurements.

The use of these measurement modes in various measurement configurations is illustrated in Appendix I.

7 Out-of-service measurement mode

This clause describes the necessary functions which an AME performing out-of-service measurements should fulfil.

In the out-of-service measurement mode, measurements are performed on a test connection which is dedicated to the measurement. This measurement mode is used for example when bringing into service a new network element or testing the performance delivered by a network portion.

7.1 Generation of traffic at the ATM layer level

In the out-of-service measurement mode, the AME should be capable of generating both test and background traffic. Background traffic comprises cell streams that are generated by the AME but on which no monitoring is performed. Test and background traffic should be programmable in order to simulate realistic traffic. The patterns of test and background traffic are to be generated in a reproducible manner.

7.1.1 Test traffic

7.1.1.1 Test cell payload format

A test cell is a cell belonging to the cell stream of the connection which is dedicated to out-of-service measurement. Its information fields are coded in order to be able to identify ATM cell transfer outcomes and to measure network performance parameters.

The payload format of the test cell is illustrated in Figure 7-1. It comprises the following consecutive fields:

- 4 bytes for a Sequence Number (SN);
- 4 bytes for a Time Stamp (TS);

- 37 Unused bytes (UN);
- 1 byte defining the Test Cell Payload Type (TCPT);
- 2 bytes for an error detecting code (CRC-16).

The test cell payload except the error detecting code is scrambled to guarantee that sufficient transitions occur and to check transparency of crossed network elements.

Except for the SN, the following conventions, also described in Recommendation I.361, are used:

- Bits within a byte are sent in decreasing order, starting with bit 8.
- Bytes are sent in increasing order, starting with byte 1.
- The first bit sent of each field is the Most Significant Bit (MSB) of that field.

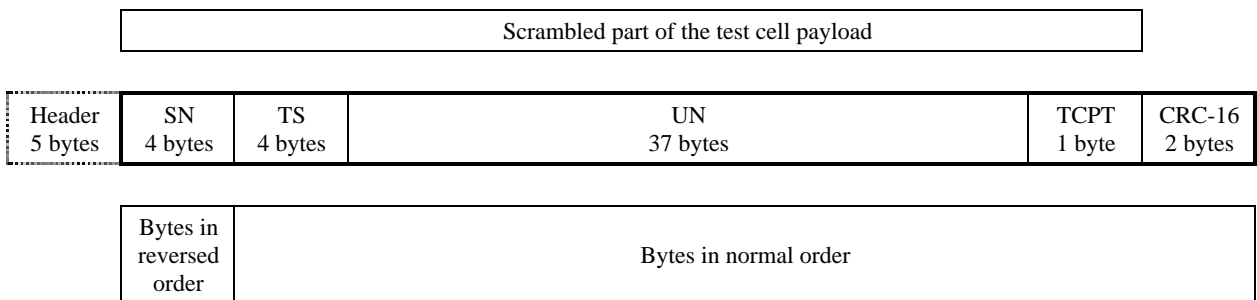

Figure 7-1/O.191 – Payload format of the test cells

Unless otherwise stated, the used field structure is the following:

- When a field is contained within a single byte, the lowest bit number of the field represents the lowest order value.
- When a field spans more than one byte, the order of bit values within each byte decreases progressively as the byte number increases. The lowest bit number associated with the field represents the lowest order value.

The transmit sequence number is a running 32-bit binary counter which is incremented by one at each test cell transmission, i.e. at each test cell exit event. The order of transmission of the 4 SN bytes is reversed and does not follow the previous conventions: The least significant byte shall be transmitted first and the most significant byte shall be transmitted last. The order of bit transmission within a byte is not reversed and follows the previous convention. Figure 7-2 details the SN field.

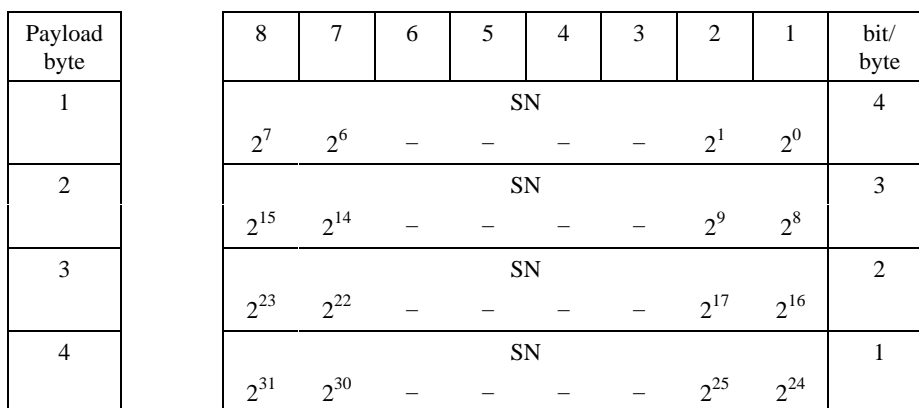

Figure 7-2/O.191 – Details of the SN field

The transmit time stamp is a 32-bit binary accumulator. The resolution of the time stamp and hence the value of the least significant bit of the accumulator is 10 ns. This resolution does not imply the use of a 100 MHz clock. For example, the time stamp may be incremented by 10 every 100 ns with the use of a 10 MHz clock. The time stamp value is placed in the time stamp field at the time of transmission of the test cell. The minimum time stamp clock frequency and accuracy as a function of a given line bit rate and measurement accuracy are for further study. Figure 7-3 details the TS field.

Payload byte	8	7	6	5	4	3	2	1	bit/byte
5	TS								1
	2^{31}	2^{30}	-	-	-	-	2^{25}	2^{24}	
6	TS								2
	2^{23}	2^{22}	-	-	-	-	2^{17}	2^{16}	
7	TS								3
	2^{15}	2^{14}	-	-	-	-	2^9	2^8	
8	TS								4
	2^7	2^6	-	-	-	-	2^1	2^0	

Figure 7-3/O.191 – Details of the TS field

Unused bytes are set to all zeroes.

The TCPT byte is used to indicate the test cell payload type. It comprises two fields: the PPI and the REV fields. The MSB of TCPT is defined as a Proprietary Payload Indicator (PPI) bit. When the PPI is set to zero, the content of the UN field is defined according to this Recommendation. When the PPI is set to one, the content of the UN field is undefined. The remaining 7 bits of the TCPT byte form the REV field which is used as a version control since future revisions of this Recommendation may define additional test functions using the UN field. The REV field can be used to maintain backwards compatibility with previous test cell definitions. The REV field (bits 1-7) is set to zero. Figure 7-4 details the TCPT field.

NOTE – If new fields are to be defined in future releases, it is envisaged to shorten the UN field and to place the new fields starting just after the TS field. For compatibility with future releases of this Recommendation, proprietary payload should better use the UN bytes located just before the TCPT byte.

Payload byte	8	7	6	5	4	3	2	1	bit/byte
46	PPI REV							1	
	2^0	2^6	2^5	2^4	2^3	2^2	2^1	2^0	

Figure 7-4/O.191 – Detail of the TCTP field

Part of the transmitted test cell payload starting with the first bit of the SN field up to the last bit of the REV field is scrambled applying the polynomial $x^9 + x^5 + 1$. At the start of each cell, the scrambler is reset to the all-zeroes state. The nine least significant bits of the current SN value are used to scramble following data bits. At the receiving side, the test cell payload is descrambled accordingly so as to recover the initial data. An illustration of the scrambling/descrambling mechanisms is given in Annex C.

Error detection is performed by means of a CRC-16 EDC with a generator polynomial of $x^{16} + x^{12} + x^5 + 1$. It is calculated at the transmit side over 46 bytes of the cell payload after they have been scrambled (see Figure 7-1). The result of the CRC calculation is placed with the least significant bit right justified in the CRC field. To ensure that an all-zeroes payload does not pass the CRC check, the CRC field shall contain the ones complement of the sum (modulo 2) of:

- 1) the remainder of $x^k (x^{15} + x^{14} + x^{13} \dots + x + 1)$ divided (modulo 2) by the generator polynomial, where k is the number of bits of the information over which the CRC is calculated; and
- 2) the remainder of the division (modulo 2) by the generator polynomial of the product of x^{16} by the information over which the CRC is calculated.

At the receive side, the syndrome of the CRC-16 is checked before descrambling.

As a typical implementation at the transmitter, the initial content of the device computing the remainder of the division is pre-set to all 1s and is then modified by division by the generator polynomial (as described above) on the information over which the CRC is to be calculated; the ones complement of the resulting remainder is put into the CRC field. As a typical implementation at the receiver, the initial content of the device computing the remainder of the division is pre-set to all 1s. The final remainder, after multiplication by x^{16} and then division (modulo 2) by the generator polynomial of the serial incoming protected bits will be (in the absence of errors) 0001110100001111 (x^{15} to x^0 respectively).

This procedure is identical to that described in Recommendation X.25 [24]. Figure 7-5 details the CRC-16 field.

Payload byte	8	7	6	5	4	3	2	1	bit/ byte
47	CRC-16								1
	2^{15}	2^{14}	-	-	-	-	2^9	2^8	
48	CRC-16								2
	2^7	2^6	-	-	-	-	2^1	2^0	

Figure 7-5/O.191 – Detail of the CRC-16 field

7.1.1.2 Profile of the test traffic

The profile of the test traffic is characterized by a set of traffic parameters such as peak cell rate, Cell Delay Variation (CDV) tolerance, distribution of instantaneous cell rate. Peak cell rate and CDV tolerance should always be defined as specified in Recommendation I.371. The precise specification of the required set of parameters and their range of values is for further study.

Whenever the AME is used for out-of-service performance measurements, it shall be ensured that the transmitted VPC/VCC cell flow contains sufficient information to check whether the connection under test is in the available state or not. Continuity checking, which forms part of the availability state determination, shall be checked either by transmitting a minimum number of one test cell every second or by transmitting end-to-end continuity check cells as defined in Recommendation I.610.

7.2 Background traffic

The background traffic shall be generated in a defined manner to ensure that the content of the cell information fields and the traffic profile for each background traffic connection is reproducible. Details require further study.

7.3 Other generation functions

7.3.1 Generation of OAM cell streams

The AME should be capable of generating end-to-end OAM performance monitoring cells associated with the test cell stream and to insert them in this test cell stream.

7.3.2 Generation of outcomes

The specification of test cell sequences corresponding to given cell transfer outcomes needs further study. For validation purposes these sequences could include: single cells with errored header, sequences of cells with missing numbers of cells, sequences of cells with out-of-sequence cells.

Generation of other outcomes at the ATM layer might be useful for validation purposes: Creation of "silent" periods on the test cell flow so as to simulate the occurrence of the loss of continuity defect defined in Recommendation I.610 is one example.

7.4 ATM cell transfer outcomes determination

Estimation of basic cell transfer outcomes comprising lost cells, misinserted cells and errored cells is the foundation for the calculation of error-related network performance parameters. These outcomes shall be determined according to the algorithm described hereafter and shown in Annex B. This algorithm is defined in order that different AMEs provide the same outcome counts while disturbed conditions are experienced. It is not intended to constrain the design of the AME to any particular implementation.

The Sequence Number field (SN) and the error detection field (CRC-16) are used to estimate cell losses, cell misinsertions and cell errors.

The first check on a received cell is to determine if errors have occurred on the test cell payload. The CRC-16 value carried in the cell is compared with the CRC-16 calculated over the test cell payload at the receive side. If these are equal, the CRC-16 is said to have a syndrome value equal to zero. In this case, the cell is considered valid; otherwise, it is considered non-valid.

When a non-valid test cell is received, a temporary counter E1 is incremented and records the number of non-valid cells received. A non-valid cell occurs as the result of either an errored cell or a misinserted cell. Characterizing these non-valid cells as lost cells or misinserted cells is postponed until the algorithm is able to take the decision with sufficient confidence. After the decision is taken, the temporary counter E1 is reset to zero.

When a valid test cell is received and contains a SN value which is not considered to be in sequence with the previously received test cell, a temporary counter Nbreak is incremented and records the sequence break(s) in the sequence. A sequence break may occur on a cell loss or on an errored SN not detected by the CRC-16. Characterizing the corresponding outcomes is postponed until the algorithm is able to take the decision. After the decision is taken, the temporary counter Nbreak is reset to zero.

For a high level of confidence, the algorithm postpones any decision, if required, until:

- either two consecutive valid cells (both CRC-16 syndrome values equal to 0) containing SN values in sequence are received. SN values are considered to be in sequence when $SN_{(n+1)} = SN_{(n)} + 1$, where the SN_x is the SN value of the x^{th} received cell,
- or one valid test cell is received and the content of its SN field is equal to SNRef.

Whenever the above decision criteria is reached, the algorithm gives the characterization of cell transfer outcomes and their respective number of occurrences when appropriate. Determining the number of lost and misinserted cells is based on the sequence number value. Basically, the difference

between the test cell SN value and the reference SN value (SNRef), incremented by the algorithm at each test cell arrival, gives the number of either the lost cells (if it is positive) or the misinserted cells (if it is negative).

In some critical conditions, the AME could enter a state where it is not capable of taking any decision for a long time and where performance assessment would not be possible. Therefore, at least one decision shall be taken over a period of time of 10 seconds. For this purpose, the algorithm includes the detection of a Loss of Performance Assessment Capability (LPAC) anomaly. See Annex A for further details.

The AME shall perform the SECB determination on cell blocks of size N. Default values of N shall be selected, in conformance with Recommendation I.356, as a function of the Peak Cell Rate (PCR) of the connection under test according to Table 7-1. Other values of N may be user selectable among the values defined in this table.

Table 7-1/O.191 – Cell block sizes and SECB thresholds

PCR (cells/second)	(User Information Rate in Mbit/s)	N (block size)	M (threshold)
$0 < x \leq 3\ 200$	$(0 < y \leq 1.23)$	128	4
$3\ 200 < x \leq 6\ 400$	$(1.23 < y \leq 2.46)$	256	8
$6\ 400 < x \leq 12\ 800$	$(2.46 < y \leq 4.92)$	512	16
$12\ 800 < x \leq 25\ 600$	$(4.92 < y \leq 9.83)$	1 024	32
$25\ 600 < x \leq 51\ 200$	$(9.83 < y \leq 19.66)$	2 048	64
$51\ 200 < x \leq 102\ 400$	$(19.66 < y \leq 39.32)$	4 096	128
$102\ 400 < x \leq 202\ 800$	$(39.32 < y \leq 78.64)$	8 192	256
$202\ 800 < x \leq 409\ 600$	$(78.64 < y \leq 157.29)$	16 384	512
$409\ 600 < x \leq 819\ 200$	$(157.29 < y \leq 314.57)$	32 768	1 024
NOTE – This table applies to the peak cell rate of the aggregate cell flow, CLP=0+1.			

A cell block of size N shall be declared a severely errored cell block if the sum of errored, lost or misinserted cell outcomes, as detected by the previously described algorithm, within the cell block is greater than $M=N/32$.

7.5 Network performance parameters calculation

7.5.1 Error-related network performance parameters

Error performance parameters should only be calculated during available time. Availability and unavailability conditions from a network performance point of view are defined in Recommendation I.357. Therefore, successfully transferred cells, errored cells, misinserted cells, lost cells and SECBs shall not be accumulated during unavailable time for the purpose of performance assessment.

The severely errored cell block ratio shall be estimated for a set of S consecutive or non-consecutive cell blocks by dividing the total number of severely errored cell blocks by S.

All calculations are based on the theoretical definition given in Recommendation I.356. Some practical details such as block delineation and blocks spanning more than one second are for further study.

7.5.2 Availability related network performance parameters

If the AME is no more capable of estimating the basic cell transfer outcomes for a period greater than 10 seconds, the LPAC state is entered and unavailability shall be declared. The 10 second period prior to the decision to enter the LPAC state is considered to be part of the unavailable time. Any SES_{ATM} occurring adjacent to this period of time will contribute to the actual unavailability period determination.

Other details are for further study

7.5.3 Delay-related network performance parameters

Mean cell transfer delay, 1-point CDV and 2-point CDV are for further study.

7.6 Other receiver functions

Other functions such as assessing the performance of UPC/NPC are for further study.

8 In-service measurement mode

This clause describes the necessary functions which an AME performing in-service measurements should fulfil.

In-service measurement is performed when testing the performance delivered by a network to a user connection. It can also be used for maintenance purposes and/or to check the OAM procedures.

In the in-service measurement mode, the live traffic of an ATM connection is monitored directly. The Fx fault management flow is analyzed to detect severe impairments on the connection. This mode makes also use of the Fx performance monitoring flow provided by ATM network elements for the measurement of some performance parameters.

This measurement mode is totally non-intrusive if protected monitoring points are provided for the connection of the AME to the physical medium. In any case, the method is non-intrusive with respect to the resource allocation provided by the network because:

- i) user traffic characteristics are specified to the network at connection set-up; and
- ii) OAM traffic characteristics are specified to the network either at connection set-up or at the time of OAM activation/deactivation.

NOTE – Part of the information covered in this clause has been taken from Recommendations I.356, I.357 and I.610.

Two methods of in-service measurements can be distinguished:

- The first one is based on measurements achieved at a single measurement point.
- The second one is based on simultaneous measurements achieved at two different measurement points.

The following subclauses describe network performance parameters evaluation achieved by observing the live traffic at a single measurement point. In-service network parameter performance estimation based on measurements carried out at different measurement points requires further study.

8.1 Error-related network performance parameters

8.1.1 General considerations

Network performance parameters related to cell errors or bit errors such as CLR, CMR and SECBR are evaluated by monitoring simultaneously the live user cell flow and the corresponding

Performance Management (PM)-OAM flow. This PM-OAM flow is part of the F4 (F5) flow associated to a VP (VC) connection and is defined in Recommendation I.610. The content of the performance management OAM cells is analyzed and the data derived from this content are compared with the data computed directly on the live user cell stream.

From the network perspective, error performance evaluation requires the use of the continuity check mechanism on the measured connection or the certainty that the live traffic source transmits at least one user cell per second during the whole measurement time.

By monitoring the adequate Fx-PM-OAM flow, in-service measurements support network performance evaluation of:

- an end-to-end VP connection using the F4 end-to-end PM-OAM flow;
- an end-to-end VC connection using the F5 end-to-end PM-OAM flow;
- a segment VP connection using the F4 segment PM-OAM flow;
- a segment VC connection using the F5 segment PM-OAM flow.

The adequate Fx-PM flow shall be activated for the monitored connection prior to the measurement if it has not been activated at connection set-up. The AME is not required to provide a means to activate/deactivate the OAM flows. Users of the AME should make use of facilities provided by network elements or by network management for this purpose. Procedures for activation/deactivation of performance monitoring and continuity check, either by OAM activation/deactivation cells or entirely by the TMN, are described in Recommendation I.610.

Depending on the capabilities of the network elements or of the customer equipment and depending on the required measurement, network performance of an ATM connection or an ATM connection segment can be evaluated at the near end for:

- the forward (or receive) direction when the Forward Monitoring (FM)-Fx-PM flow is activated;
- the backward (or send) direction when the Backward Reporting (BR)-Fx-PM flow is activated;
- both the forward and backward (or send and receive) directions when the forward monitoring and backward reporting Fx PM flows are activated.

In addition to the observation of the Fx-PM flows, ATM defects on the measured connection are detected by monitoring the corresponding Fx fault management OAM flow. Figure 8-1 illustrates the conventions used. This reference measurement configuration assumes that NPP estimation is performed on a bi-directional ATM connection at one end (the near end) on a signal sent in the forward direction by the other end (the far end). Basic flows monitored for the assessment of the forward direction are:

- the user cell flow in the forward direction;
- the forward monitoring PM flow related to the forward direction and co-directional with it;
- the fault management flow in the forward direction for the detection of defects related to this direction (Vx-AIS, Vx-LOC).

Complementary flows simultaneously monitored at the same measurement point for the assessment of the backward direction are:

- the backward reporting PM flow related to the backward direction and contra-directional with this direction (this BR stream flowing from the far end to the near end can only be activated when the FM flow is activated in the backward direction);
- the fault management flow in the forward direction for the detection of defects related to the backward direction (Vx-RDI).

NPP estimation for one direction of an ATM connection is obtained by monitoring only the basic flows examined for the assessment of the forward direction of the ATM connection.

The absence, an interruption or severe degradation of the Fx-PM flow(s) may affect the capability of the AME to measure or continue to measure performance parameters. Therefore, the recurrent presence of OAM-PM cells is monitored. For this purpose, two indications are provisionally defined: the Loss of Forward Monitoring Flow (LFMF) and the Loss of Backward Reporting Flow (LBRF). See Annex A for definitions.

Appendix I shows examples of Fx-PM flow directions for some end-to-end and segment connection measurement cases.

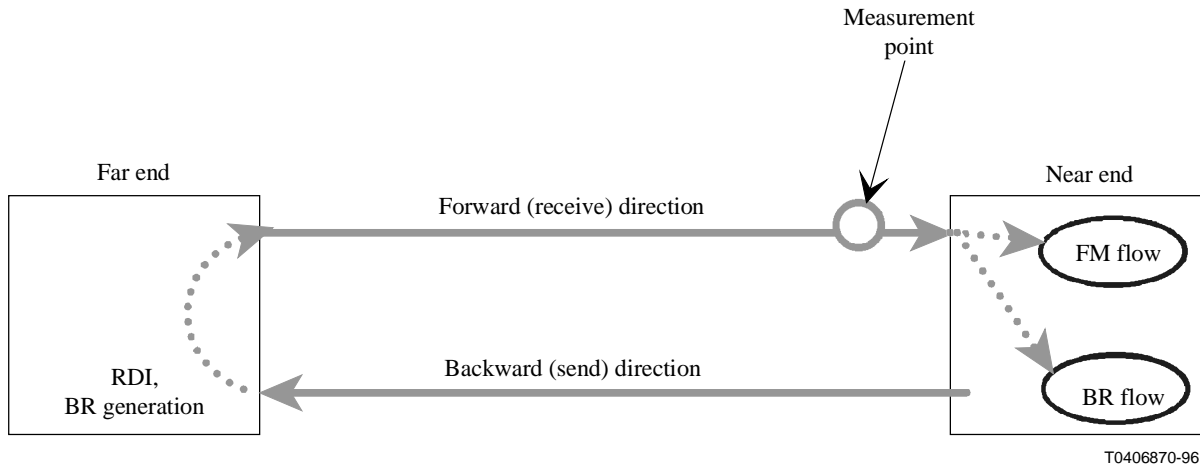

Figure 8-1/O.191 – Evaluation of the forward and backward directions

It should be noted that in-service measurements of CER may not provide accurate results when high bit error ratios or bursty errors are experienced.

8.1.2 Monitored cell flows

Table 8-1 defines the cell population which shall be monitored to detect cell transfer outcomes for measurement on a VP connection. Table 8-2 lists further outcomes related to defects and indications at the ATM layer which shall also be detected. All these outcomes are observed on the forward direction at the measurement point located close to the near end as defined in Figure 8-1.

**Table 8-1/O.191 – Monitored cells to determine cell transfer outcomes
for a VP connection**

Monitored connection type	End-to-end VP	Segment VP
Monitored Fx-PM-OAM flow	End-to-end F4	Segment F4
Header of monitored Fx-PM OAM cells (Note 7)	GFC (Note 1): BBBB VPI: VPI value of the monitored VPC VCI: 4 PTI (Notes 2, 3): 0B0 CLP (Notes 2, 4): B	VPI: VPI value of the monitored VPC VCI: 3 PTI (Notes 2, 3): 0B0 CLP (Notes 2, 4): B
Header of monitored "user cells"	GFC (Note 1): BBBB VPI: VPI value of the monitored VPC VCI: As per definition of "user cells" at F4 level given in Recommendation I.610 PTI (Note 5): BBB CLP (Note 6): D	VPI: VPI value of the monitored VPC VCI: As per definition of "user cells" at F4 level given in Recommendation I.610 PTI (Note 5): BBB CLP (Note 6): D

NOTE 1 – Applicable only to measurements at a UNI.

NOTE 2 – B indicates the bit is a "don't care bit".

NOTE 3 – Recommendation I.361 specifies that the second bit of the PTI may be 0 or 1 and is available for use by the appropriate ATM layer function. As Recommendation I.610 does not specify different ATM processing functions based on the received value of this bit, the AME shall monitor cells regardless of the value of this bit.

NOTE 4 – Recommendation I.361 specifies that the CLP bit may be 0 or 1. As Recommendation I.610 does not give more information about CLP, the AME shall monitor OAM cells regardless of the value of the CLP bit.

NOTE 5 – As Recommendation I.610 does not specify any restriction on the value of the PTI for a VPC, the AME shall monitor user cells regardless of the PTI value.

NOTE 6 – D indicates that the bit may be 0 or a "don't care" bit depending on the traffic component of the ATM connection. CLP=0 or CLP=0+1 as defined in Recommendation I.371 are to be measured.

NOTE 7 – The Fx-PM-OAM flow comprises the Fx-FM flow for the assessment of the connection in the forward direction and the Fx-BR flow for reporting the performance assessment related to the backward direction of the connection.

Table 8-2/O.191 – Monitored outcomes related to ATM defects and indications for a VP connection

Monitored connection type	End-to-end VP	Segment VP
Monitored ATM outcomes on the Fx-fault management-OAM flow for the forward direction	VP-AIS } } (See Annex A) VP-LOC }	VP-AIS } } (See Annex A) VP-LOC }
Monitored ATM outcomes on the Fx-FM-OAM flow for the forward direction	VP-LFMF (Note 1)	VP-LFMF (Note 1)
Monitored ATM outcomes on the Fx-fault management-OAM flow for the backward direction	VP-RDI (See Annex A)	VP-RDI (See Annex A)
Monitored ATM outcomes on the Fx-BR-OAM flow for the backward direction	VP-LBRF (Note 2)	VP-LBRF (Note 2)
<p>NOTE 1 – The VP-LFMF indication is defined only for measurement purposes. It indicates the loss of F4 forward monitoring flow. Criteria to declare or release the VP-LFMF indication are given in Annex A. Processing of the VP-LFMF requires further study.</p> <p>NOTE 2 – The VP-LBRF indication is defined only for measurement purposes. It indicates the loss of F4 backward reporting flow. Criteria to declare or release the VP-LBRF indication as well as its processing require further study.</p>		

Table 8-3 defines the cell population which shall be monitored to detect cell transfer outcomes for measurement on a VC connection. Table 8-4 lists further outcomes related to defects and indications at the ATM layer which shall also be detected. All these outcomes are observed on the forward direction at the measurement point located close to the near end as defined in Figure 8-1.

Table 8-3/O.191 – Monitored cells to determine cell transfer outcomes for a VC connection

Monitored connection type	End-to-end VC	Segment VC
Monitored Fx-PM-OAM flow	End-to-end F5	Segment F5
Header of monitored Fx-PM-OAM cells (Note 5)	GFC (Note 1): BBBB VPI: VPI value of the monitored VCC VCI: VCI value of the monitored VCC PTI: 101 CLP (Notes 2, 3): B	VPI: VPI value of the monitored VCC VCI: VCI value of the monitored VCC PTI: 100 CLP (Notes 2, 3): B

Table 8-3/O.191 – Monitored cells to determine cell transfer outcomes for a VC connection (concluded)

Monitored connection type	End-to-end VC	Segment VC
Header of monitored "user cells"	GFC (Note 1): BBBB VPI: VPI value of the monitored VCC VCI: VCI value of the monitored VCC PTI: As per definition of "user cells" at F5 level given in Recommendation I.610 CLP (Note 4): D	VPI: VPI value of the monitored VCC VCI: VCI value of the monitored VCC PTI: As per definition of "user cells" at F5 level given in Recommendation I.610 CLP (Note 4): D
<p>NOTE 1 – Applicable only to measurements at a UNI.</p> <p>NOTE 2 – B indicates the bit is a "don't care bit".</p> <p>NOTE 3 – Recommendation I.361 specifies that the CLP bit may be 0 or 1. As Recommendation I.610 does not give more information about CLP, the AME shall monitor OAM cells regardless of the value of the CLP bit.</p> <p>NOTE 4 – D indicates that the bit may be 0 or a "don't care" bit depending on the traffic component of the ATM connection. CLP=0 or CLP=0+1 as defined in Recommendation I.371 are to be measured.</p> <p>NOTE 5 – The Fx-PM-OAM flow comprises the Fx-FM flow for the assessment of the connection in the forward direction and the Fx-BR flow for reporting the performance assessment related to the backward direction of the connection.</p>		

Table 8-4/O.191 – Monitored outcomes related to ATM defects and indications for a VC connection

Monitored connection type	End-to-end VC	Segment VC
Monitored ATM outcomes on the Fx fault management flow for the forward direction	VC-AIS } } (See Annex A) VC-LOC }	VC-AIS } } (See Annex A) VC-LOC }
Monitored ATM outcomes on the Fx FM OAM flow for the forward direction	VC-LFMF (Note 1)	VC-LFMF (Note 1)
Monitored ATM outcomes on Fx fault management flow for the backward direction	VC-RDI (See Annex A)	VC-RDI (See Annex A)
Monitored ATM outcomes on the Fx-BR-OAM flow for the backward direction	VC-LBRF (Note 2)	VC-LBRF (Note 2)
<p>NOTE 1 – The VC-LFMF indication is defined only for measurement purposes. It indicates the loss of F5 forward monitoring flow. Criteria to declare or release the VC-LFMF indication are given in Annex A. Processing of VC-LFMF requires further study.</p> <p>NOTE 2 – The VC-LBRF indication is defined only for measurement purposes. It indicates the loss of F5 backward reporting flow. Criteria to declare or release the VC-LBRF indication as well as its processing require further study.</p>		

8.1.3 ATM outcomes determination

The reference algorithm to be used is described in Figure C.4/I.356 "Estimation of cell transfer performance parameters in case of lost OAM cells".

8.1.4 Parameters calculation

See Annex C/I.356 "Cell transfer performance measurement methods" for details.

NOTE – At the date of completion of this Recommendation, Annex C/I.356 does not provide sufficient information to process all network performance parameters.

8.2 Availability-related network performance parameters

8.2.1 General considerations

ATM outcomes defined in 5.2.2 detected during an error-related NPP measurement are necessary and sufficient to determine availability NPPs as described in Recommendation I.357. The level of confidence on the availability ratio and the mean time between outages depends upon the duration of the measurement period. Long observation periods on various ATM connections are necessary to provide meaningful statistics from a network perspective.

8.2.2 Monitored cell flows

Requires further study.

8.3 Delay-related network performance parameters

8.3.1 General considerations

Non-conforming cells and 1-point CDV measurements are performed by simply analyzing the arrival times of the appropriate flow of cells belonging to the monitored connection.

An estimation of CTD can be achieved by analyzing the forward monitoring Fx-PM flow when the optional time stamp field of the Fx-PM cell defined in Recommendation I.610 is adequately filled with a time stamp. The accuracy of the measurement requires further study with respect to the sampling effect of PM-OAM cells and the use of two clocks located at different geographical sites.

2-point CDV measurement needs further study.

8.3.2 Monitored cell flows

Tables 8-5 and 8-6 give the definition of monitored cells for a VP and a VC connection, respectively.

Table 8-5/O.191 – Monitored cells for a VP connection

Header of monitored cells	GFC (Note 1): For further study VPI: VPI of the monitored connection VCI: For further study PTI (Note 2): For further study CLP (Note 2): For further study
Monitored ATM outcomes	For further study
Other	For further study
NOTE 1 – Applicable only to measurements at a UNI. NOTE 2 – The PTI and CLP values of cells which shall be monitored are defined in the traffic contract.	

Table 8-6/O.191 – Monitored cells for a VC connection

Header of monitored cells	GFC (Note 1): For further study VPI: VPI of the monitored connection VCI: VCI of the monitored connection PTI (Note 2): For further study CLP (Note 2): For further study
Monitored ATM outcomes	For further study
Other	For further study
NOTE 1 – Applicable only to measurements at a UNI. NOTE 2 – The PTI and CLP values of cells, which shall be monitored, are defined in the traffic contract.	

8.3.3 Measurement method

The measurement method for the 1-point CDV parameter that allows to compute the range of CDV shall conform to Recommendation I.356.

The measurement method for the determination of non-conforming cells shall comply with 7.1/I.356 "A method for computing the number of non-conforming cells".

9 Physical interfaces of the ATM measuring equipment

The ATM Layer can be accessed at various physical interfaces and bit rates. Those relevant at the time of completion of this Recommendation are listed in the following subclauses.

9.1 General interface characteristics and bit rates

The generator part and/or the receiver part of the AME shall enable access to one or more interfaces and bit rates listed in Tables 9-1 to 9-3. Tables 9-1 and 9-2 define interfaces which can likely be found within a network as a physical measurement access point. These interfaces can be practically considered as NNI. Table 9-3 lists currently recommended B-ISDN user network interfaces. Although some recommended bit rates are nominally the same for UNIs or NNIs, recommended physical characteristics such as levels, clock frequency accuracy or clock recovery range may differ between UNI and NNI.

Table 9-1/O.191 – Physical interfaces based on the PDH bit rates

Recommendation applicable to ...	Bit rate (kbit/s) and signal structure				
	1544 Frame-based	2048 Frame-based	34 368 Frame-based	44 736 Frame-based	139 264 Frame-based
ATM cell mapping into PDH	G.804	G.804	G.804	G.804	G.804
Synchronous frame structures at primary and secondary levels	G.704	G.704	–	–	–
Frame and multiplexing structures	–	–	G.832	G.832	G.832
Interface characteristics	G.703	G.703	G.703	G.703	G.703
Control of jitter and wander	G.824	G.823	G.823	G.824	G.823

Table 9-2/O.191 – Physical interfaces based on the SDH bit rates

Recommendation applicable to ...	Bit rate (kbit/s) and signal structure			
	155 520 Frame-based	155 520 Cell-based	622 080 Frame-based	622 080 Cell-based
Physical layer specification	I.432.2	I.432.2	I.432.2	I.432.2
Frame structure	G.707	None	G.707	None
Digital interface specification	G.703 (Note 1) G.957 (Note 2) I.432 (Note 3)	G.703 (Note 1) G.957 (Note 2) I.432 (Note 3)	G.957 (Note 2) I.432 (Note 3)	G.957 (Note 2) I.432 (Note 3)
Control of jitter and wander	G.825	G.825	G.825	G.825
NOTE 1 – For an electrical interface.				
NOTE 2 – For an optical interface.				
NOTE 3 – Applicable to the T _B reference point at the B-ISDN user network interface.				

Table 9-3/O.191 – B-ISDN user network interfaces

Bit rate (kbit/s)	Signal structure	Recommendation
1 544	Frame-based	I.432.3
2 048	Frame-based	I.432.3
25 600		I.432.5
51 840	Frame- or cell-based	I.432.4
155 520	Frame- or cell-based	I.432.2
622 080	Frame- or cell-based	I.432.2

9.2 Interface characteristics – Generator part

If the AME comprises a generator part, the characteristics of its digital output port shall comply with the Recommendations referred to in Table 9-4 (as applicable).

Table 9-4/O.191 – Interface characteristics of the generator output port

Characteristic	Relevant Recommendation(s)
Bit rate	G.702, G.707, I.432.2, I.432.3, I.432.4, I.432.5
Signal structure	G.804, G.707, I.432.2, I.432.3, I.432.4, I.432.5
Signal amplitude and waveform	G.703, I.432.2, I.432.3, I.432.4, I.432.5
Impedance	G.703, I.432.2, I.432.3, I.432.4, I.432.5
Return loss	G.703, I.432.2, I.432.3, I.432.4, I.432.5
Maximum output jitter	G.823, G.824, G.825, I.432.2, I.432.3, I.432.4, I.432.5

9.2.1 Synchronization of the generator part

The AME shall provide means to synchronize its generator part to one of the synchronization sources listed below:

- internal clock (accuracy is for further study);
- external clock input (specifications for further study);
- clock recovered from the input signal to the AME receiver part – if provided.

9.3 Interface characteristics – Receiver part

If the AME comprises a receiver part, the characteristics of its digital input port shall comply with the Recommendations referred to in Table 9-5 (as applicable).

Table 9-5/O.191 – Interface characteristics of the receiver input port

Characteristic	Relevant Recommendation(s)
Bit rate	G.702, G.707, I.432.2, I.432.3, I.432.4, I.432.5
Signal structure	G.804, G.707, I.432.2, I.432.3, I.432.4, I.432.5
Input sensitivity and waveform	G.703, I.432.2, I.432.3, I.432.4, I.432.5
Protected (electrical) monitoring points	G.772
Impedance	G.703, I.432.2, I.432.3, I.432.4, I.432.5
Return loss	G.703, I.432.2, I.432.3, I.432.4, I.432.5
Maximum tolerable input jitter	G.823, G.824, G.825, I.432.2, I.432.3, I.432.4, I.432.5

9.3.1 Information available at physical interfaces

Additional information concerning physical layer events (e.g. faults, alarms, error performance) can be obtained at the physical interface. Whether and how this information should be evaluated requires further study.

10 Miscellaneous functions

These functions do not directly influence the ATM network performance parameter measurements and may be considered as optional for the AME.

10.1 Display

The AME may provide a display to simplify its configuration and the access to the measurement results.

10.2 Anomaly and defect simulation on the output signal

To simulate impairments, anomalies and defects may be superimposed on the output signal of the AME.

10.3 Alarm and error indication

The AME may display on its front panel the most important anomalies and defects detected by its receiver part.

10.4 Event time stamping

Time stamping of events relevant to performance monitoring (e.g. lost cell, severely errored second, unavailable period) requires further study.

10.5 Output to external recording devices

The AME may provide the capability to connect an external recording device (e.g. a printer) using an interface in accordance with Recommendations V.24 and V.28.

10.6 Remote control port

The AME may be remotely controllable using an interface in accordance with IEEE 488 [26]/IEC 625 [25] Standards or Recommendations V.24 [22] and V.28 [23].

10.7 TMN interface

The AME may have an appropriate Q interface providing TMN facilities.

11 Operating conditions

11.1 Environmental conditions

The electrical and functional performance requirements shall be met when operating the AME under the conditions specified in Recommendation O.3 [21].

11.2 Behaviour in case of power failure

A power failure shall be recognized by the AME.

ANNEX A

Criteria for the detection of anomalies, defects and indications

VP-AIS

The VP-AIS defect shall be declared as soon as one of the following occurs:

- A VP-AIS cell is received.
- A transmission path AIS defect is detected.
- A VPC defect is detected (e.g. loss of VPC continuity).

The VP-AIS defect shall be released when a user cell or a continuity check cell is received.

VP-RDI

The VP-RDI defect shall be declared as soon as a VP-RDI cell is received. The VP-RDI defect shall be released when no VP-RDI cell is received during a period of 2.5 ± 0.5 seconds.

VP-LOC

The VP-LOC defect shall be declared when the receiver does not receive any user cell or continuity check cell within a time interval of 3.5 ± 0.5 seconds. The VP-LOC defect shall be released when a user cell or a continuity check cell is received.

VC-AIS

The VC-AIS defect shall be declared as soon as one of the following occurs:

- A VC-AIS cell is received.
- A transmission path AIS defect is detected.
- A VPC defect or a VCC defect is detected (e.g. loss of VPC continuity or loss of VCC continuity).

The VC-AIS defect shall be released when a valid user cell or a continuity check cell is received.

VC-RDI

The VC-RDI defect shall be declared as soon as a VC-RDI cell is received. The VC-RDI defect shall be released when no VC-RDI cell is received during a period of 2.5 ± 0.5 seconds.

VC-LOC

The VC-LOC defect shall be declared when the receiver does not receive any user cell or continuity check cell within a time interval of 3.5 ± 0.5 seconds. The VC-LOC defect shall be released when a user cell or a continuity check cell is received.

VP-LFMF

The following criterion is provisional and may be superseded in future releases by another definition resulting from the work on Recommendations related to network aspects.

The VP-LFMF indication shall be declared when the number of received user cells since the latest F4 Forward Monitoring cell is greater than $3.5 \times N$ (i.e., after at least 2 PM-OAM cells have been lost) where N is the nominal cell block size activated at the VP level.

The VP-LFMF indication shall be released as soon as a single F4 Forward Monitoring cell has been correctly received without error detected by CRC-10.

The monitored F4 flow shall be either the end-to-end flow or the segment flow depending on the actual measurement.

This indication is valid only when the forced insertion option for the F4 PM flow is used.

VC-LFMF

The following criterion is provisional and may be superseded in future releases by another definition resulting from the work on Recommendations related to network aspects.

The VC-LFMF indication shall be declared when the number of received user cells since the latest F5 Forward Monitoring cell is greater than $3.5 \times N$ (i.e., after at least 2 PM-OAM cells have been lost) where N is the nominal cell block size activated at the VC level.

The VC-LFMF indication shall be released as soon as a single F5 Forward Monitoring cell has been correctly received without error detected by CRC-10.

The monitored F5 flow shall be either the end-to-end flow or the segment flow depending on the actual measurement.

This indication is valid only when the forced insertion option for the F5 PM flow is used.

VP-LBRF

For further study.

VC-LBRF

For further study.

LPAC

The Loss of Performance Assessment Capability indicates that the AME is no longer capable of measuring network performance parameters with sufficient confidence. Entering and exiting this state shall be time-stamped with a one-second resolution.

The LPAC state shall be declared if the basic OOS cell transfer outcome measurement algorithm was not able to take any decision during the last 10 seconds (refer to Annex B for the definition of a decision).

The LPAC state shall be cleared by the AME when two consecutive received test cells are error free and the contents of their SN fields are in sequence (i.e. $SN(n+1) = SN(n)+1$ where $SN(n+1)$ corresponds to cell #n+1 and $SN(n)$ to the previously received cell #n).

ANNEX B

Measurement algorithms

B.1 Basic out-of-service cell transfer outcome measurement algorithm

Ndiff SNRef – SN for the current cell
 Odiff SNRef – SN for the previous cell
 S CRC-16 syndrome
 E1 Number of cells received with bad CRC-16s and not already identified
 Nbreak Number of consecutive sequence breaks not already identified

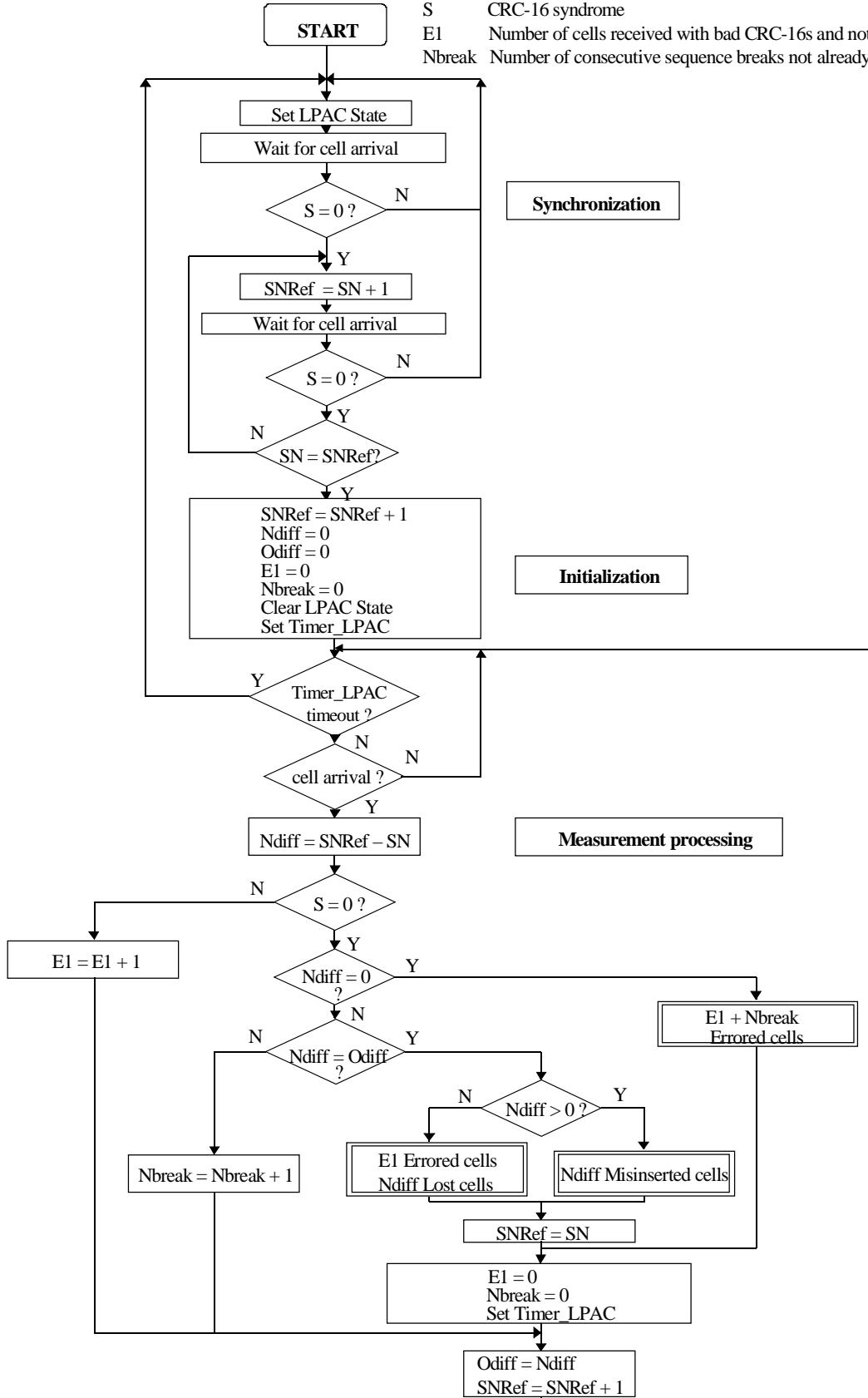

T0406880-96

Figure B.1/O.191 – Out-of-service cell transfer outcome measurement algorithm

The time-out value for the Timer_LPAC is 10 seconds.

The SNRef value shall be initialized with the SN value, incremented by 1, read in the first valid received test cell after the activation of the algorithm.

A cell arrival event occurs when defects are not present at the physical transmission level and when a test cell is identified on the connection under test.

The algorithm takes a decision when:

- either two consecutive received test cells are error-free and the contents of their SN fields are in sequence (i.e. $SN(n+1) = SN(n) + 1$ where $SN(n+1)$ corresponds to cell #n+1 and $SN(n)$ to the previously received cell #n); or
- one error free test cell is received and the content of its SN field is equal to SNRef.

Decisions are highlighted in Figure B.1 by double lined boxes.

ANNEX C

Test cell payload scrambling/descrambling

C.1 Scrambling/descrambling

The following figures describe the functional test cell payload scrambling/descrambling mechanisms with the $x^9 + x^5 + 1$ polynomial. They are provided for explanation purposes and do not preclude any other implementation. It is required, nevertheless, that the operation of the scrambler/descrambler is functionally identical to that depicted in Figures C.1 and C.2 even though the actual hardware or software implementation may be different.

Figure C.1 shows the scrambler circuit in serial form using a shift register. At the start of the cell (cell start), the scrambler is reset to the all-zeroes state. Cell data, starting with the most significant bit of the least significant byte of the sequence number (transmission of the SN is byte reversed), is added modulo 2 with the modulo 2 sum of the x^9 and x^5 terms from the shift register. The scrambled data is output and also enters the shift register.

Figure C.2 shows the descrambler circuit in serial form. At the start of the cell (cell start), the descrambler is reset to the all-zeroes state. Scrambled cell data, starting with the most significant bit of the least significant byte of the sequence number (the SN is byte reversed), is added modulo 2 with the modulo 2 sum of the x^9 and x^5 terms from the shift register. The scrambled data also enters the shift register.

C.2 Scrambling and CRC

The following two examples illustrate the result of the scrambling plus the CRC calculation on the ATM test cell. The TS, PPI and REV fields are assumed to be equal to 0.

a) Sequence number = 0

```
00 00 00 00 00 00 00 00 00 00 00 00 00 00 00 00 00 00 00
00 00 00 00 00 00 00 00 00 00 00 00 00 00 00 00 00 00 00
00 00 00 00 00 00 00 F7 40
```

b) Sequence number = 1

01 08 C2 72 AC 37 A6 E4 50 AD 3F 64 96 FC 9A 99 80 C6 51 A5
 FD 16 3A CB 3C 7D D0 6B 6E C1 6B EA A0 52 BC BB 81 CE 93 D7
 51 21 9C 2F 6C D0 BB 1C

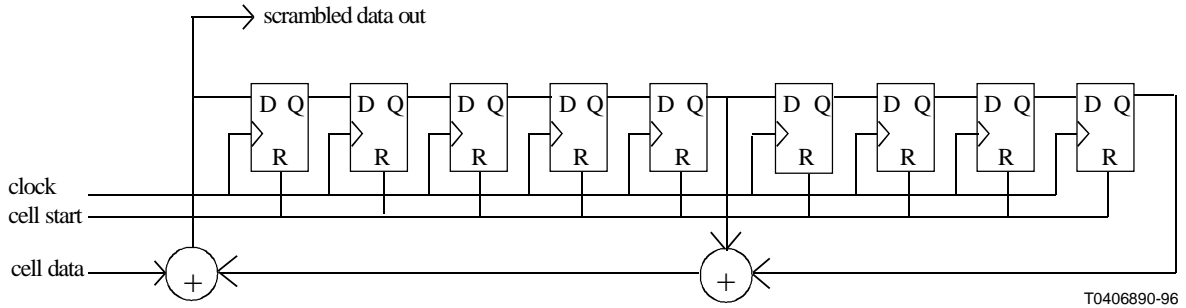

Figure C.1/O.191 – Scrambler circuit using polynomial $x^9 + x^5 + 1$

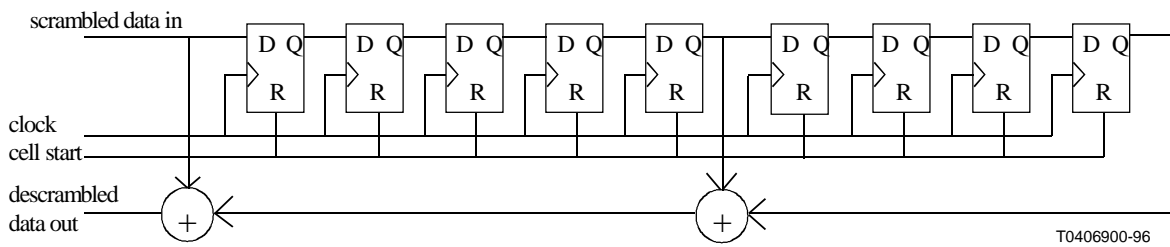

Figure C.2/O.191 – Descrambler circuit using polynomial $x^9 + x^5 + 1$

APPENDIX I

Examples of use of the different measuring modes

I.1 Use of the out-of-service measurement mode

Figure I.1 shows an example of a measurement configuration using the out-of service measurement mode of the AME. In this configuration, two AMEs are used, one at each end of the ATM VP or VC connection set-up for the measurement. The AME at location A sends test cells on the monitored connection. An additional background traffic may be generated on other connections at location A in order to simulate a more realistic traffic between location A and the nearest connecting point. The AME at location B analyzes the test cells received at this location. The two AMEs are acting as VP or VC terminating end-points.

In order to achieve simultaneous point-to-point measurements in the two directions of a bi-directional ATM connection, the AME at location B may simultaneously generate test cells towards location A and the AME at location A analyze the received test cells.

Figure I.2 illustrates a variation of the preceding example with the use of a loop-back at location B. Test cells received at location B on the monitored ATM connection are looped back towards location A by the AME. Loopback can be achieved by other means also: the AME at location B can

be replaced by a NE providing the loopback capabilities described in Recommendation I.610. This configuration may be useful in some cases for the measurement of CTD assuming that the CTD is the same for the two opposite directions and that the delay introduced by the loopback is known or small compared to the expected CTD.

I.2 Use of the in-service measurement mode

I.2.1 End-to-end test

Figure I.3 shows an example of a measurement configuration using the in-service measurement mode of the AME, with network elements at locations A and B providing ATM termination connection functions.

In this example, the Fx-PM flow is activated only in the direction A towards B. Forward monitoring cells are generated by the VP or VC terminating equipment. Measurements of the VP or VC connection for this direction are carried out at location B by analyzing simultaneously the user cells and the Fx-PM forward monitoring cells flowing in the same direction.

End-to-end performance evaluation is performed when measurements are carried out at MP number n.

Measurement at intermediate MPs allows the localization of a faulty segment. For this purpose, measurements can be carried out successively at MPs number n, n – 1, n – 2, ... until the detected trouble disappears. Measurement at MP number 1 provides the performance evaluation of the user access line when the equipment at location A is a customer equipment.

For a bi-directional connection, network performance parameters for both directions can be evaluated at location B as shown in Figure I.4:

- activating the Fx-PM forward monitoring and reporting flows for the direction B towards A;
- activating the Fx-PM forward monitoring flow for the direction A towards B;
- analyzing the user cells, the forward monitoring and the reporting Fx-PM flows in the A to B cell flow at one measurement point.

1 point CDV can be measured at any MP independently of any Fx-PM flow activation/deactivation.

I.2.2 Segment test

Figure I.5 shows an example of a measurement configuration for testing segments.

Forward monitoring cells of the Fx-PM flow are generated by the first network element of a segment. Segment test provides performance evaluation for the forward direction of the whole segment when the AME is located at MP number 3 or of part of it when it is located at MP number 1 or 2.

Measurement of the performance delivered by the VP or VC connection is carried out at location 3 by analyzing simultaneously the user cells and the Fx segment PM forward monitoring cells flowing in the same direction. A similar measurement performed at location 1 or 2 yields an estimation of the performance of a correspondingly restricted connection portion.

I.2.3 UPC/NPC testing

Measurement of the performance of a UPC/NPC mechanism is carried out by comparing the number of cells that are passed by the UPC/NPC to the number of cells that are conforming to the standard cell conformance algorithm. This scenario implies that the AME accesses both sides of the equipment where the UPC/NPC is located. Figure I.6 shows an example of measurement configuration.

The AME derives the number of conforming cells by a direct computation on the cell stream before it enters the UPC/NPC mechanism.

The number of cells that are passed by the UPC/NPC mechanism may be obtained by analyzing the Fx segment PM forward monitoring cell stream that either includes the UPC/NPC mechanism or is adjacent to it. In particular, if the Fx segment PM forward monitoring cells are inserted just behind the UPC/NPC mechanism, the number of cells that are passed by the UPC/NPC is carried by the TUC field of the Fx segment PM forward monitoring cell.

I.3 Combined use of out-of-service and in-service measurement modes

Figure I.6 shows an example of measurement configuration using both out-of-service and in-service measurement modes of the AME.

An out-of-service measurement is performed on a VP or VC connection as described in I.1, the test traffic being generated by the AME at location A. This AME is also generating the Fx-PM traffic associated to the main test traffic.

All measurements described in the in-service measurement mode can be carried out on this traffic by the AME shown on the figure and connected at location n – 2.

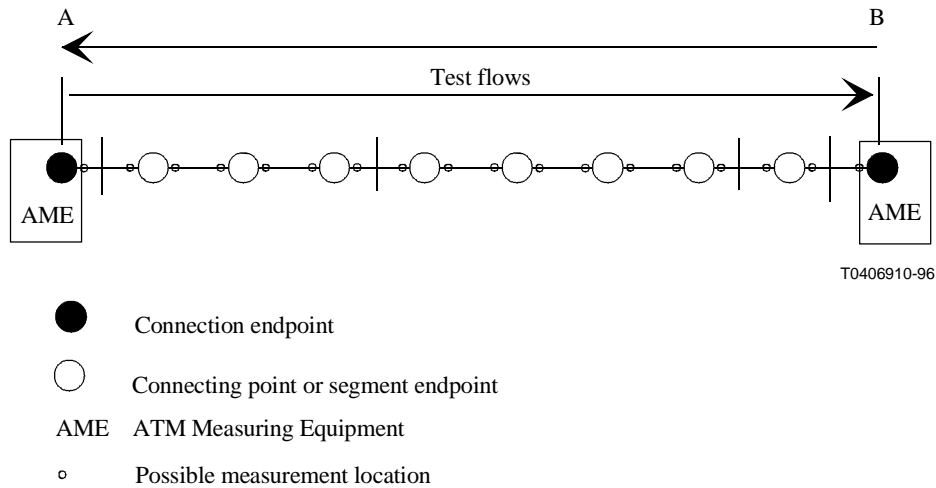
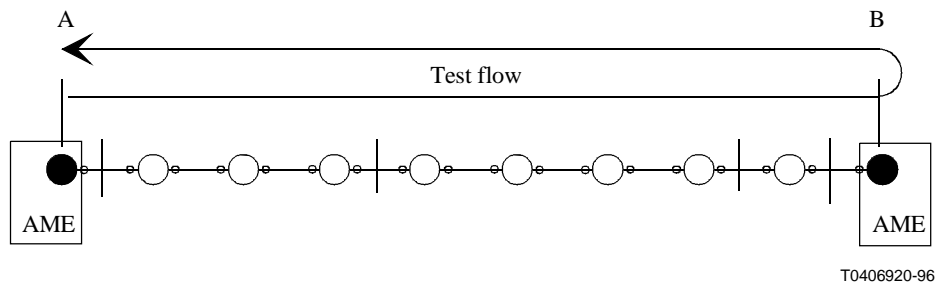
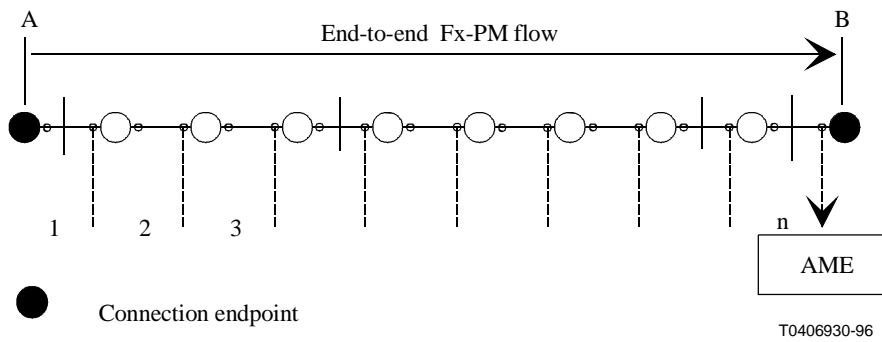

Figure I.1/O.191 – Out-of-service end-to-end test



- Connection endpoint
- Connecting point or segment endpoint
- AME ATM Measuring Equipment
- Possible measurement location

Figure I.2/O.191 – Out-of-service test with test flow loopback



- Connection endpoint
- Connecting point or segment endpoint
- AME ATM Measuring Equipment
- Possible measurement location

Figure I.3/O.191 – In-service end-to-end test

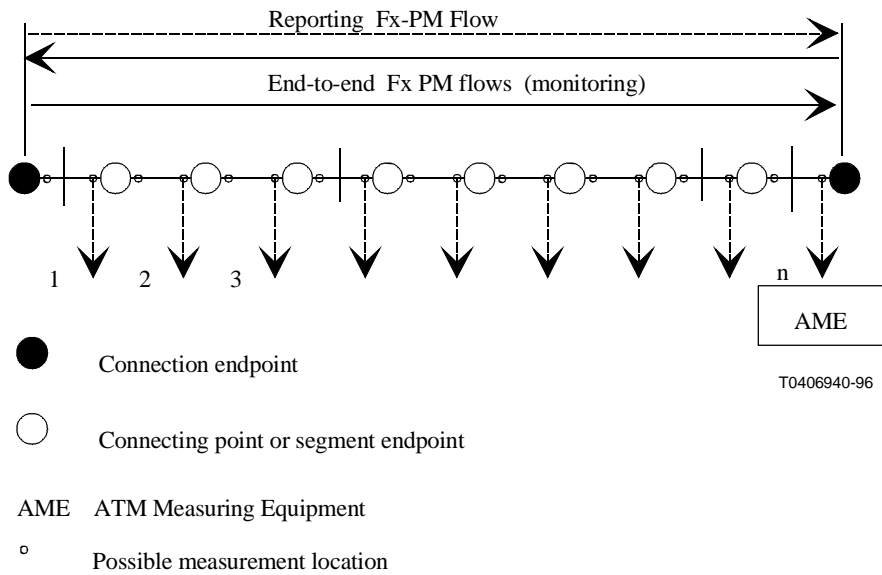

Figure I.4/O.191 – In-service end-to-end test

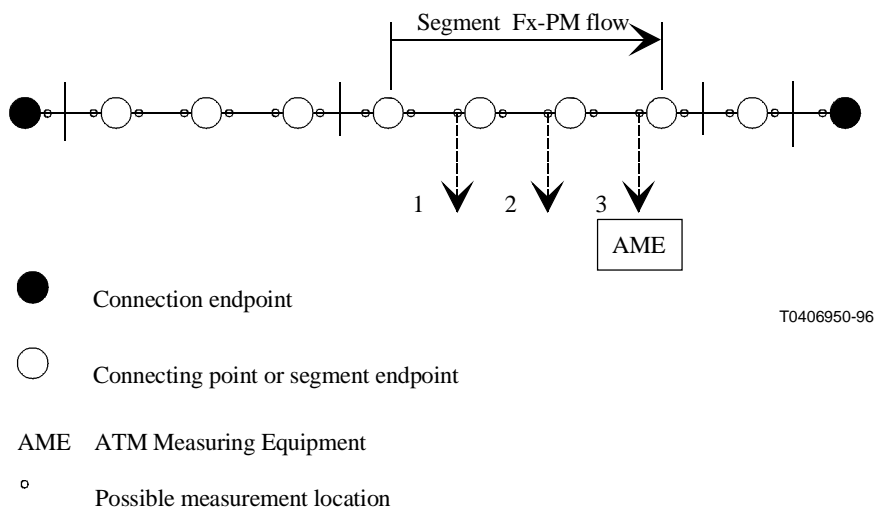

Figure I.5/O.191 – In-service segment test

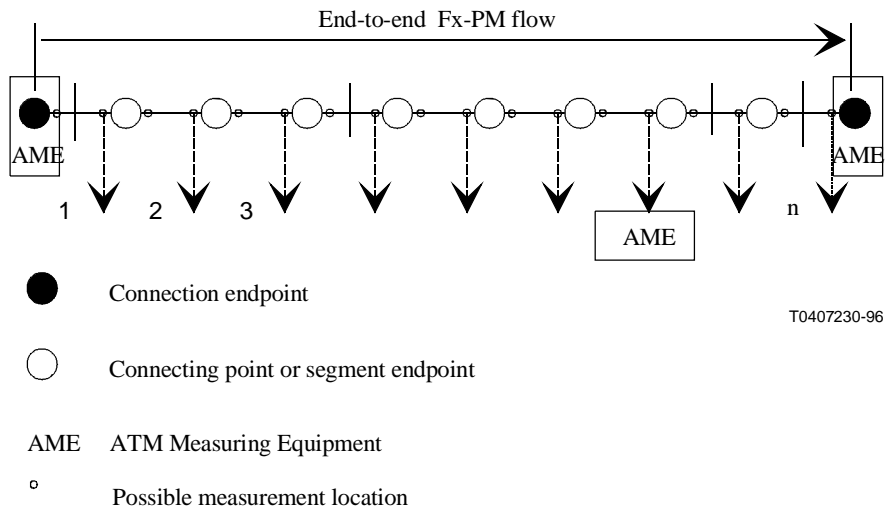

Figure I.6/O.191 – Combination of in-service and out-of-service modes

ITU-T RECOMMENDATIONS SERIES

- Series A Organization of the work of the ITU-T
- Series B Means of expression: definitions, symbols, classification
- Series C General telecommunication statistics
- Series D General tariff principles
- Series E Overall network operation, telephone service, service operation and human factors
- Series F Non-telephone telecommunication services
- Series G Transmission systems and media, digital systems and networks
- Series H Audiovisual and multimedia systems
- Series I Integrated services digital network
- Series J Transmission of television, sound programme and other multimedia signals
- Series K Protection against interference
- Series L Construction, installation and protection of cables and other elements of outside plant
- Series M Maintenance: international transmission systems, telephone circuits, telegraphy, facsimile and leased circuits
- Series N Maintenance: international sound programme and television transmission circuits
- Series O Specifications of measuring equipment**
- Series P Telephone transmission quality, telephone installations, local line networks
- Series Q Switching and signalling
- Series R Telegraph transmission
- Series S Telegraph services terminal equipment
- Series T Terminals for telematic services
- Series U Telegraph switching
- Series V Data communication over the telephone network
- Series X Data networks and open system communication
- Series Z Programming languages