



INTERNATIONAL TELECOMMUNICATION UNION

**ITU-T**

**O.82**

TELECOMMUNICATION  
STANDARDIZATION SECTOR  
OF ITU

**SPECIFICATIONS FOR MEASURING EQUIPMENT**

---

**GROUP-DELAY MEASURING EQUIPMENT  
FOR THE RANGE 5 TO 600 kHz**

**ITU-T Recommendation O.82**

(Extract from the *Blue Book*)

---

## NOTES

1 ITU-T Recommendation O.82 was published in Fascicle IV.4 of the *Blue Book*. This file is an extract from the *Blue Book*. While the presentation and layout of the text might be slightly different from the *Blue Book* version, the contents of the file are identical to the *Blue Book* version and copyright conditions remain unchanged (see below).

2 In this Recommendation, the expression “Administration” is used for conciseness to indicate both a telecommunication administration and a recognized operating agency.

© ITU 1988, 1993

All rights reserved. No part of this publication may be reproduced or utilized in any form or by any means, electronic or mechanical, including photocopying and microfilm, without permission in writing from the ITU.

## Recommendation O.82

### GROUP-DELAY MEASURING EQUIPMENT FOR THE RANGE 5 TO 600 kHz

(Geneva, 1972)

The requirements for the characteristics of a group-delay measuring set for data circuits which are described below must be adhered to in order to ensure compatibility between equipments standardized by the CCITT, and produced by different manufacturers.

#### 1 Measuring principle

In the case of group-delay distortion measurements over a line (straightaway measurements), a signal for phase demodulation is required on the receiving side whose frequency corresponds exactly to the modulation (split) frequency on the transmitting side and whose phase does not change during the measurement. With the proposed measuring principle, this frequency is generated in a split-frequency oscillator in the receiver whose frequency is controlled with the aid of a reference carrier. The reference carrier is amplitude modulated with the same modulation frequency as the measuring carrier and is transmitted over the path to be measured in periodical alternation with the measuring carrier. During the changeover from measuring carrier to reference carrier no phase or amplitude surge must occur in the sending signal. For the sake of identification the reference carrier is furthermore amplitude modulated with an identifying signal.

If the path to be measured has different group delay and/or attenuation for the measuring carrier and the reference carrier, a phase and/or amplitude surge appears at the output of the path to be measured at the carrier changeover point within the receiver. This phase or amplitude surge is evaluated by the receiver of the measuring set. Thus, the receiver is provided with a phase measuring device for the purpose of group-delay measurements. This measuring device includes the above-mentioned frequency controlled split-frequency oscillator whose phase is automatically adjusted to the mean value derived from the phases of the split frequencies transmitted with the measuring and the reference carriers. The split-frequency voltage fed to the phase meter is taken from the output of an amplitude demodulator which can simultaneously be used for measuring amplitude variations. In order to recognize the actual measuring frequency on the receiving side – particularly during sweep measurements – a frequency discriminator may be provided.

If the frequency of the measuring carrier differs from the frequency of the reference carrier during the measurement and if the path to be measured has different group-delay and attenuation values for the two frequencies, a square-wave signal appears at the outputs of the phase meter, the amplitude demodulator and the frequency discriminator in the receiver, whose amplitudes are proportional to the respective measuring results – referred to the frequency of the reference carrier – and whose frequency corresponds to the carrier changeover frequency on the transmitting side. These three square-wave signals are subsequently evaluated with the aid of controlled rectifiers and allow indications, together with the correct signs, of differences in group-delay distortion, attenuation and measuring frequency between measuring and reference carrier frequencies.

#### 2 Technical details

##### 2.1 Transmitter

The modulation split frequency shall be 416.66 Hz (= 10 000 Hz/24). With the aid of this signal the reference and measuring carriers are amplitude modulated to a modulation depth of 40%. Both sidebands are transmitted. The modulation distortion factor shall be smaller than 1%. The changeover from measuring carrier to reference carrier is carried out within a switching time of  $\leq 100$  microseconds. The changeover frequency is rigidly tied to the modulation frequency by binary frequency division and is 41.66 Hz (416.6 Hz/10). The carrier changeover occurs at the minimum of the modulation envelope. Deviations of  $\leq \pm 20$  microseconds are admissible. The carrier frequency which is not transmitted in each case has to be suppressed by at least 60 dB referred to the sending signal.

The identifying signal which is required for identifying the reference carrier is also rigidly tied to the modulation (split) frequency. The assigned frequency of 1666 Hz is derived by multiplying the modulation (split) frequency by four or by dividing 10 kHz by six. The rectangular-shaped identifying signal derived from 10 kHz through frequency division can be used for direct modulation after having passed through an RC lowpass filter with a time

constant of  $T = 43$  microseconds since a pure sinusoidal form is not required in this case. The modulation depth is 20%. The identifying signal is only transmitted during the last 2.4 milliseconds of the reference carrier sending time. The shape of the different signals on the transmitting side shown as a function of time and their respective forms can be seen from Figure 1/O.82.

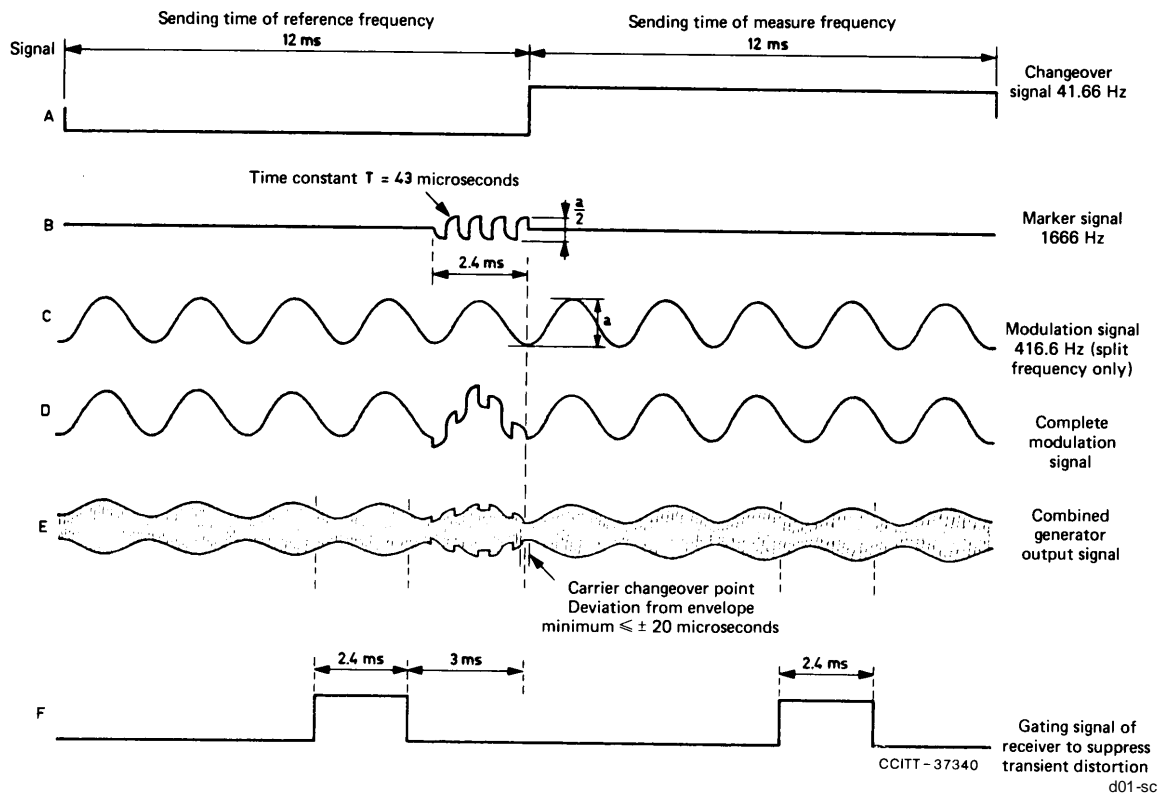

FIGURE 1/O.82  
Timing of various signals of group-delay measuring set

## 2.2 Receiver

### 2.2.1 Group-delay measurements (see Figure 2/O.82)

The signal coming from the path to be measured is demodulated and the modulation frequency of 416.6 Hz so obtained is filtered out by a bandpass filter. This modulation voltage is rectangularity phase modulated, the frequency of the phase modulation being equivalent to the changeover frequency, 41.66 Hz. The phase deviation is proportional to the group-delay difference between the measuring carrier and the reference carrier. The phase demodulation is carried out in a phase meter whose second input is fed, for example, by a 10 kHz oscillator via a frequency divider 24/1. This oscillator forms a closed-phase control loop involving the phase meter and a lowpass filter which suppresses the changeover frequency. Thus, the modulation frequency generated in the receiver corresponds exactly to the modulation frequency coming from the transmitter.

At the output of the phase meter a 41.66-Hz square-wave voltage is obtained, whose amplitude is proportional to the measuring result. In order to enable a correct evaluation of this signal, controlled rectification is required. The control voltage is derived from the modulation (split) frequency which is generated in the receiver by frequency division (10/1). The correct phase position with regard to the transmitting signal is enforced with the aid of the identifying signal 1666 Hz. The controlled rectifier is connected both to an indicating instrument and to the direct current output.

### 2.2.2 Amplitude measurements

If the amplitude measurement is to be referred also to the reference carrier, the signal at the output of the amplitude demodulator (41.66-Hz square-wave proportional to  $\Delta a$ ) can be subsequently evaluated as already described in the case of the group-delay measurements. Furthermore, it is possible to indicate the respective absolute carrier amplitude.

### 2.2.3 Frequency measurements

For sweep measurements it is necessary to generate in the receiver a voltage which is proportional to the measuring frequency. This can be achieved with the aid of a frequency discriminator which, in turn, supplies its output voltage to a controlled rectifier. The indicated measuring result is the frequency difference between the measuring carrier and the reference carrier. Optionally, only the measuring carrier frequency may be indicated.

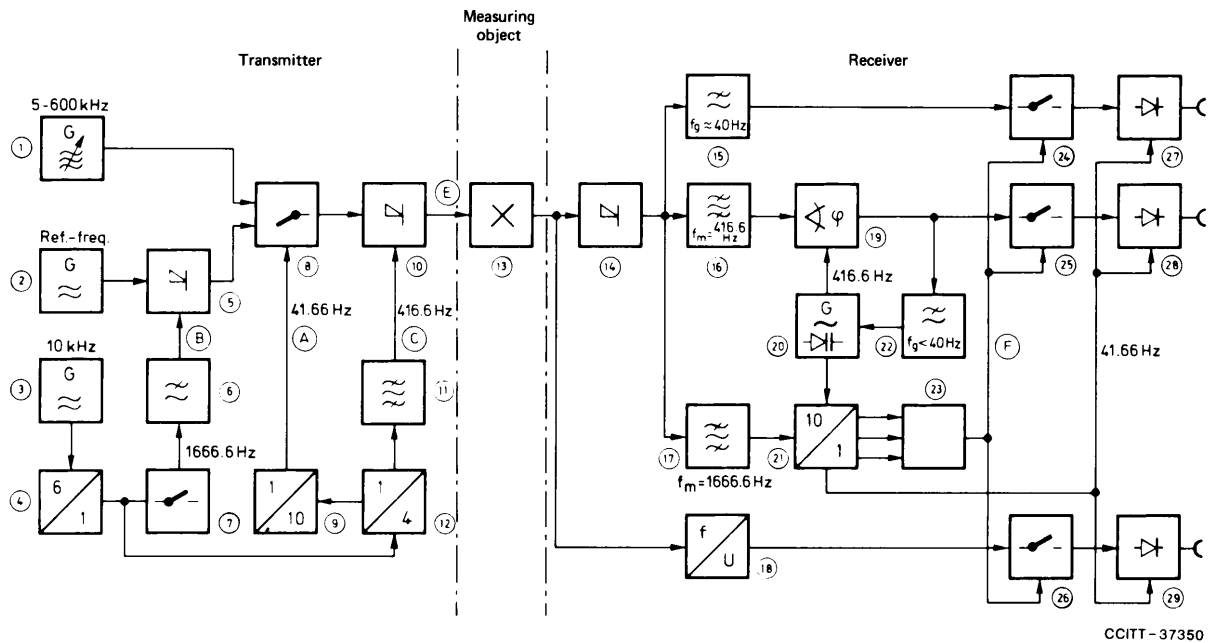

- 1 generator, measuring frequency
- 2 generator, reference frequency
- 3 oscillator, 10 kHz
- 4, 9, 12, 21 frequency dividers
- 5, 10 amplitude modulators
- 6, 15, 22 low-pass filter
- 7 gate, marker signal
- 8 carrier changeover switch
- 11, 16 bandpass filter, modulation frequency
- 13 measuring object

- 14 amplitude demodulator
- 17 bandpass filter, marker frequency
- 18 frequency discriminator
- 19 phasemeter
- 20 controlled oscillator
- 23 And circuit
- 24, 25, 26 gates
- 27, 28, 29 controlled rectifiers
- A to F signals see Figure 1/O.82

d02-sc

FIGURE 2/O.82

Principle of group-delay measuring set

### 2.2.4 Blanking of transient distortion

Due to the carrier changeover it may happen that transient distortions occur in the path to be measured as well as in the receiver. These interfering signals can effectively be blanked out by means of gate circuits. The gates will release the ensuing measuring devices only during those periods which are indicated in Figure 1/O.82.

## 3 General

The transmitter output and the receiver input shall provide 135 and 150 ohms conditions which must be balanced and earth free. In addition, 75 ohms unbalanced conditions shall be provided.

## 4 Specifications for a group-delay measuring set for the range 5 to 600 Hz

### 4.1 General

#### 4.1.1 Accuracy of group-delay measurements (see also § 4.2.1 below):

– 5 kHz to 10 kHz .....	$\leq \pm 5$ microseconds	} $\pm 3\%$ of measuring range (see Note 1 at the end of this Recommendation)
– 10 kHz to 50 kHz .....	$\leq \pm 2$ microseconds	
– 50 kHz to 300 kHz .....	$\leq \pm 1$ microsecond	
– 300 kHz to 600 kHz .....	$\leq \pm 0,5$ microsecond	

Outside a temperature range of +5° C to +40° C the stated accuracy may be affected by variations of the modulation frequency, causing a measuring error of 4% instead of 3% (see § 4.1.4 below).

The additional error due to amplitude variations shall not exceed:

– variations up to 10 dB .....	$\pm 0.5$ microsecond
– variations up to 20 dB .....	$\pm 1.0$ microsecond
– variations up to 30 dB .....	$\pm 2.0$ microseconds

#### 4.1.2 Measuring frequency ..... 5 kHz to 600 kHz

##### 4.1.2.1 Measuring frequency accuracy:

– in temperature range +5° C to +40° C .....	$\leq \pm 1\% \pm 500$ Hz of actual reading
– in temperature range +5° C to +50° C .....	$\leq \pm 2\% \pm 500$ Hz of actual reading

#### 4.1.3 Reference frequency switchable ..... 25 kHz (See Note 2 at the end of this Recommendation) 84 kHz 432 kHz

##### 4.1.3.1 Reference frequency accuracy:

– in temperature range +5° C to +40° C .....	$\leq \pm 1\%$
– in temperature range +5° C to +50° C .....	$\leq \pm 3\%$

##### 4.1.4 Modulation frequency accuracy<sup>1)</sup>:

– in temperature range +5° C to +40° C .....	416.66 Hz $\pm 0.5\%$
– in temperature range +5° C to +50° C .....	416.66 Hz $\pm 1\%$

##### 4.1.4.1 Modulation depth<sup>1)</sup> ..... 0.4 $\pm 0.05$

##### 4.1.4.2 Modulation distortion factor<sup>1)</sup> ..... $\leq 1\%$ (See Note 3 at the end of this Recommendation)

#### 4.1.5 Identifying frequency<sup>1)</sup> (derived from modulation frequency)..... 1.666 kHz

##### 4.1.5.1 Modulation depth<sup>1)</sup> ..... 0.2 $\pm 0.05$

##### 4.1.5.2 Sending time of identifying signal<sup>1)</sup> ..... 2.4 milliseconds terminating with the end of the sending time of the reference frequency

4.1.5.3 The identifying signal shall commence with an increase in the amplitude of the carrier as shown in Figure 1/O.82.

#### 4.1.6 Changeover frequency<sup>2)</sup> (derived from modulation frequency) ..... 41.66 Hz

##### 4.1.6.1 Carrier changeover time<sup>2)</sup> ..... less than 100 microseconds

##### 4.1.6.2 Deviation between carrier changeover point and envelope minimum<sup>2)</sup> ..... $\leq \pm 0.02$ millisecond

1) Requirements that have to be met on grounds of compatibility between equipments made by different manufacturers.

2) Requirements that have to be met on grounds of compatibility between equipments made by different manufacturers.

4.1.7	<i>Range of environmental conditions</i> <sup>3)</sup>	
4.1.7.1	Power supply voltage variation .....	± 10%
4.1.7.2	Temperature range .....	+5° C to +40° C
	Temperature range for storage and transport .....	-40° C to +70° C
4.1.7.3	Relative humidity.....	45% to 75%
4.1.8	<i>Additional facilities</i>	
4.1.8.1	Speaker facilities.....	Optional
4.1.8.2	Internal checking circuit shall be provided to verify the proper operation of the group-delay and attenuation distortion measurement functions using appropriate outputs from the sender.	
4.1.8.3	Facilities for fitting external filters to reduce interference from adjacent traffic bands.....	Optional (See Note 4 at the end of this Recommendation)
4.2	<i>Sender</i>	
4.2.1	Error introduced by the sender in the overall accuracy of the group-delay measurements (as indicated in § 4.1.1 above) shall not exceed <sup>2)</sup> :	
	- 5 kHz to 10 kHz.....	± 0.5 microsecond
	- 10 kHz to 50 kHz.....	± 0.2 microsecond
	- 50 kHz to 300 kHz.....	± 0.1 microsecond
	- 300 kHz to 600 kHz.....	± 0.05 microsecond
4.2.2	Range of send levels (average carrier power)..... (The maximum send level may be restricted as an option.)	-40 dBm to + 10 dBm
4.2.2.1	Send level accuracy .....	≤ ± 0.5 dB
	At the reference frequency.....	≤ ± 0.3 dB
4.2.3	Output impedance (frequency range 5 to 600 kHz):	
4.2.3.1	Balanced, earth free .....	135,150 ohms
	Return loss .....	≥ 30 dB
	Signal balance ratio.....	≥ 40 dB
4.2.3.2	Unbalanced .....	75 ohms
	Return loss .....	≥ 40 dB
4.2.4	Harmonic distortion of send signal .....	≤ 1% (40 dB)
4.2.5	Spurious distortion of send signal.....	≤ 0.1% (60 dB)
4.2.6	Frequency sweep rate .....	Adjustable from 0.2 kHz/sec to 10 Hz/sec. At least 6 sweep rates shall be provided
4.2.7	A facility shall be included in the sender so that, if required, prior to measurement the test and reference carrier frequencies can be measured to a resolution of 1 Hz. This may be achieved by providing suitable outputs at the sender for use with an external frequency counter.	
4.3	<i>Receiver</i>	
4.3.1	Input level range .....	-40 dBm to + 10 dBm
4.3.1.1	Dynamic range of receiver.....	30 dB

<sup>3)</sup> These values are provisional and require further study.

4.3.2	Input impedance (frequency range 5 to 600 kHz):	
4.3.2.1	Balanced, earth free .....	135, 150 ohms
	Return loss .....	≥ 30 dB
	Signal balance ratio.....	≥ 40 dB
4.3.2.2	Unbalanced .....	75 ohms
	Return loss .....	≥ 40 dB
4.3.3	Range for measuring group-delay/frequency distortion: 0 to ± 10, ± 20, ± 50, ± 100, ± 200, ± 500, ± 1000 microseconds.	
4.3.3.1	Accuracy of group-delay measurements in accordance with §§ 4.1.1 and 4.2.1 above.	
4.3.4	Measuring ranges for attenuation/frequency distortion measurement: 0 to ± 2, ± 5, ± 10, ± 20, ± 50 dB <sup>4</sup> ).	
4.3.4.1	Accuracy (+5° C to +50° C) .....	± 0.1 dB ± 3% of measuring range
4.3.5	Measuring range for input level measurements at the reference frequency.....	- 20 dBm to + 10 dBm
4.3.5.1	Accuracy (+5° C to +40° C) .....	± 0.25 dB
	Accuracy (+5° C to +50° C) .....	± 1 dB
4.3.6	D.c. outputs shall be provided to drive an X-Y recorder.	
4.3.7	Measuring range for frequency measurements .....	5 to 60 kHz 50 to 150 kHz 150 to 600 kHz
4.3.7.1	Accuracy of frequency indication.....	± 2% ± 500 Hz

*Note 1* – Measuring range – indicated value at full-scale deflection on the range in use.

*Note 2* – It was originally proposed to use a fixed reference frequency of 1800 Hz. Due to the fact that the instrument for higher frequencies shall be applicable in three main frequency ranges (6 kHz to 54 kHz, 60 kHz to 108 kHz, 312 kHz to 552 kHz), three reference frequencies have to be provided which are in the middle of the respective frequency band.

*Note 3* – Modulation distortion factor:

$$\frac{\text{r.m.s. value of unwanted sidebands}}{\text{r.m.s. value of wanted sidebands}} \times 100\%$$

*Note 4* – Administrations requiring to make measurements in the 60-108 kHz or 312-552 kHz ranges without removing traffic from adjacent groups or supergroups in their national section should add a clause:

“To minimize the effect of interference to measurements arising from traffic on adjacent groups or supergroups, the manufacturer shall provide a facility whereby an Administration can insert in the frequency discriminator path a zero-loss bandpass filter having a passband appropriate to the test being made and having an impedance of 75, 135 or 150 ohms.”

Administrations should note that they will be responsible for a national instruction giving the relevant details of the filter and amplifier arrangement to be used, taking note of the manufacturer’s information or the signal levels at this point.

### **Bibliography**

COENNING (F.): Progress in the Technique of Group Delay Measurements, *NTZ Communications Journal*, Vol. 5, pp. 256-264, 1966.

<sup>4</sup>) On the ± 50 dB range, the stated accuracy applies over ± 30 dB only (see § 4.3.1.1).