



INTERNATIONAL TELECOMMUNICATION UNION

CCITT

THE INTERNATIONAL
TELEGRAPH AND TELEPHONE
CONSULTATIVE COMMITTEE

M.3604

(10/92)

MAINTENANCE: ISDN

**APPLICATION OF MAINTENANCE
PRINCIPLES TO ISDN PRIMARY
RATE ACCESS**



Recommendation M.3604

FOREWORD

The CCITT (the International Telegraph and Telephone Consultative Committee) is a permanent organ of the International Telecommunication Union (ITU). CCITT is responsible for studying technical, operating and tariff questions and issuing Recommendations on them with a view to standardizing telecommunications on a worldwide basis.

The Plenary Assembly of CCITT which meets every four years, establishes the topics for study and approves Recommendations revised by its Study Groups. The approval of Recommendations by the members of CCITT between Plenary Assemblies is covered by the procedure laid down in CCITT Resolution No. 2 (Melbourne, 1988).

Recommendation M.3604 was revised by Study Group IV and was approved under the Resolution No. 2 procedure on the 5th of October 1992.

CCITT NOTE

In this Recommendation, the expression "Administration" is used for conciseness to indicate both a telecommunication administration and a recognized private operating agency.

© ITU 1993

All rights reserved. No part of this publication may be reproduced or utilized in any form or by any means, electronic or mechanical, including photocopying and microfilm, without permission in writing from the ITU.

Recommendation M.3604

APPLICATION OF MAINTENANCE PRINCIPLES TO ISDN PRIMARY RATE ACCESS

(Melbourne 1988 as Rec. I.604; revised and renumbered 1992)

Abstract

This Recommendation defines capabilities and functions used by the network to maintain the physical layer of ISDN primary rate access.

Keywords

- ISDN;
- maintenance;
- primary rate access.

1 Scope of application

This Recommendation covers the maintenance of that part of the ISDN subscriber primary rate access which is controlled by the network. The Recommendation follows the maintenance principles as defined in Recommendation M.20 [1] and applies to the primary rate access connected to the local exchange.

The scope of this Recommendation is to describe the minimum functions required to maintain the subscriber primary rate access. They are applicable to any primary rate access.

The principle of controlled maintenance (as defined in Recommendation M.20 [1]) is applied for maintaining the subscriber primary rate access.

Controlled maintenance is a method of sustaining a desired technical performance by the systematic application of supervision, testing and performance sampling in order to minimize preventive maintenance and to reduce corrective maintenance.

2 Network configuration for maintenance activities

Figure 1/M.3604 gives the basis for the general maintenance principles of the subscriber access.

3 Failure detection

3.1 General

Unlike the ISDN basic access, the digital section of the ISDN subscriber primary rate access is never deactivated (as seen by the exchange); continuous automatic supervision of the correct functioning of layer 1 up to NT2 is always operating. This supervision is called continuous automatic supervision of layer 1.

Automatic supervision of the correct functioning of the D-channel layers 2 and 3 is also operating. This supervision is called automatic supervision of layers 2 and 3 of the D-channel protocol.

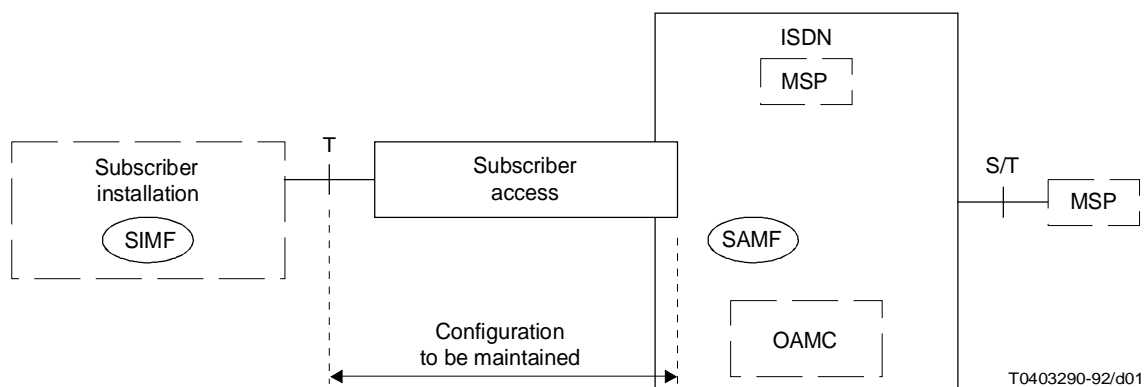

MSP Management Service Provider
 OAMC Operation Administration Maintenance Centre
 SAMF Subscriber Access Management Function
 SIMF Subscriber Installation Management Function
 See Recommendation M.3600 [2] for detailed discussion of the terms.

Note 1 – The subscriber access contains a digital link which can use different varieties of transmission techniques and media. Figure 2/M.3604 shows examples of configurations made by using existing digital line systems and multiplexers complying with G.700 [7] - and G.900 [8] - Series Recommendations.

Note 2 – A local exchange should be able to connect different types of digital line systems and different types of subscriber installations at V₃ interfaces complying with Recommendation Q.512 [9].

Note 3 – The use of different types of digital line systems shall not affect the subscriber installation complying with Recommendation I.431 [10].

Note 4 – The subscriber access shall comply with the CRC procedure defined in Recommendations G.704 [5] and G.706 [6].

Note 5 – In some countries, the subscriber installation is allowed to control maintenance functions in the subscriber access.

FIGURE 1/M.3604
Configuration for the maintenance of primary access

3.2 Automatic supervision

3.2.1 Objectives

This supervision is realized by continuous automatic mechanisms located in various pieces of equipment of the ISDN primary rate access. These automatic mechanisms are never deactivated and are generally based on the operation of CRC information which is given by the CRC procedure associated with the link between the customer and the local exchange. These mechanisms are complemented by the detection of malfunctioning of particular items, e.g. loss of power supply, loss of incoming signal, loss of frame alignment. Minimum functions which could be allocated to the subscriber installation and exchange termination are listed below. Further details of these functions and those of the digital section are found in Annex A, where various options concerning the handling of CRC functions are described.

3.2.2 NT2 functions

The functions allocated to the NT2 are listed below:

- detection of loss of incoming signal;
- detection of loss of frame alignment;
- detection of AIS and RAI;
- generation of frame signal;
- CRC code generation;

- RAI generation;
- CRC monitoring of the incoming signal (network-to-user);
- detection of CRC error information (user-to-network);
- CRC error reporting to the network (optional in 1544 kbit/s systems).

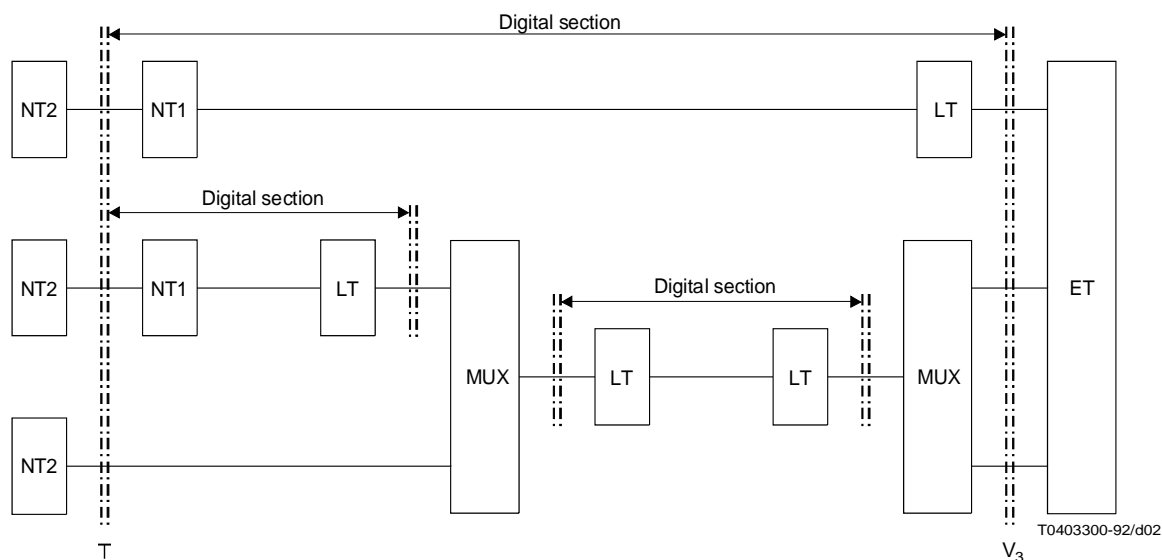

Note – Digital sections may include zero, one or more regenerators.

FIGURE 2/M.3604
Examples of equipment configurations in the ISDN subscriber primary rate access

3.2.3 ET functions

The functions which are allocated to the ET are listed below:

- detection of loss of incoming signal;
- detection of loss of frame alignment;
- detection of AIS, generation of AIS (optional in 1544 kbit/s systems);
- detection of RAI;
- generation of frame signal;
- CRC code generation;
- RAI generation;
- CRC monitoring of the incoming signal (user-to-network);
- detection of the CRC error information (network-to-user);
- CRC error reporting to the user (optional in 1544 kbit/s systems).

The exchange termination may optionally detect the CRC error information reported by the user side.

The RAI is generated towards NT2 upon detection by the ET of a fault in the input direction (loss of signal, loss of frame alignment, detection of AIS).

The ET has the option to evaluate the transmission performance based on the statistical treatment of the local and remote CRC error reports and on the fault indications.

The transmission performance evaluation is based on a permanent processing of the elementary results presented by the continuous error monitoring of the digital transmission link. The result of this processing will give information on the transmission quality level (normal quality, degraded quality, unacceptable quality) and on the unavailability of the access (see § 5.6).

3.3 *Automatic supervision of layers 2 and 3 of the D-channel protocol*

This covers supervision of activities of layers 2 and 3 of the D-channel protocol. Automatic supervision of layers 2 and 3 will be made by self-acting mechanisms implemented in the network (e.g. in the ET).

There are three categories of automatic supervision which may be performed by layer 2 and layer 3 of the D-channel protocols:

- service provision incapability detection (e.g. incapability of layer 2 to establish a data link connection);
- protocol misoperation detection;
- error monitoring (e.g. the layer 2 CRC procedure can detect the occurrence of an errored frame).

These events should be recorded as discussed in Recommendation M.3640 [4].

3.4 *Continuity test*

For further study.

4 System protection

When a confirmed fault is detected which has an adverse effect on the availability and/or functionality of network equipment, the access is considered “out of service due to failure” and call attempts may be rejected to prevent further damage or to remove the adverse effect.

5 Failure indication

5.1 *Default indication signals*

- a) AIS – as defined in Recommendation I.431 [10].
- b) RAI – as defined in Recommendation I.431 [10].

5.2 *State tables*

State tables associated with failures in the primary rate access are given in Recommendation I.431 [10].

5.3 *Generation of defect indication signals by the NT2*

The NT2 functions are listed in § 3.2.2.

The generation of RAI toward the ET is used to indicate the loss of incoming layer 1 capability.

5.4 *Generation of defect indication signals by the subscriber access*

The digital link functions are listed in Annex A for each option within the access.

5.5 *Generation of defect indication signals by the exchange termination*

The exchange termination functions are listed in § 3.2.3.

The generation of RAI toward the NT1 is used to indicate the loss of incoming layer 1 capability.

5.6 *Transmission quality monitoring by the exchange*

5.6.1 *Error performance parameters*

According to Recommendations M.20 [1] and M.2100 [3], the anomaly and defect indications are treated on a statistical basis.

5.6.2 *Error performance evaluations*

The access is considered by the local exchange to be “unavailable”, “unacceptable” or “degraded” according to Recommendation 2100 [3].

5.7 *Failure information from the exchange*

A defect confirmed by the exchange and related to a subscriber access and/or a subscriber installation shall be reported to the OAMC in a message.

The detection of a degraded or an unacceptable quality level or of the unavailability of the access by the exchange shall be reported to the OAMC in a message.

The message could be presented after an automatic identification of a failed Maintenance Entity (ME) has been made (see § 6).

5.8 *Failure information to the subscriber installation*

The detection of a degraded or unacceptable quality level by the exchange may be reported to the user by the transmission of a state indication.

6 Failure localization

6.1 *Automatic confirmation of failure within the subscriber primary rate access*

An automatic test procedure to confirm a detected possible failure condition within the subscriber access should be provided. It shall be initiated by an automatic reaction of the exchange, following abnormal conditions which have been detected by the processes presented above, i.e. continuous supervision of layer 1, supervision of layers 2 and 3 of the D-channel protocol.

If failures are detected in the D-channel layers 2 and 3 communication, clear differentiation between failures within the subscriber installation and within the subscriber access should be possible.

6.2 *Failed maintenance entity identification*

6.2.1 *General*

Such a function has to be made on demand or automatically following the indication of failure conditions by the network or following a subscriber complaint. It is necessary, before undertaking the appropriate action, to identify (i.e. to know) the maintenance entity affected by the failure.

6.2.2 *Objectives*

The main objective of this function, which is controlled by the SAMF, is to indicate to the OAMC whether the failure is:

- within the ET;
- within the digital transmission link (NT1 to LT);
- within the subscriber installation.

6.3 Loopbacks for maintenance of the subscriber primary rate access

6.3.1 Location of loopbacks

Possible loopback locations for failure localization and verification controlled by the SAMF are shown in Figure 3/M.3604.

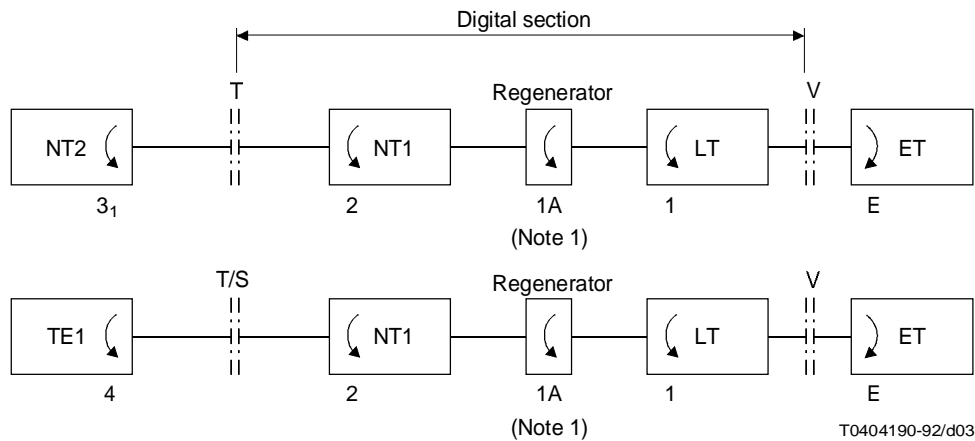

Note 1 – The digital section may contain zero, one or more regenerators.
Note 2 – For an explanation of 1, 1A, 2, 3₁, 4 and E, see Table 1/M3604.

FIGURE 3/M.3604
Location of the loopbacks for maintenance of the general equipment configuration of the subscriber primary rate access

6.3.2 Characteristics of loopbacks

The characteristics of the loopbacks are given in Table 1/M.3604.

6.4 Failure localization mechanisms

See Figure 4/M.3604.

If a subscriber access failure is confirmed by the exchange and if the failure is not located in the exchange, then

- either the loopback 2 can be established under control of the exchange, in which case:
 - i) if the loopback 2 is successful, the exchange considers the subscriber access to be functioning correctly;
 - ii) if the loopback 2 is unsuccessful, the exchange reports to the OAMC;
- or, if the loopback 2 cannot be established under control of the exchange, then the exchange informs the OAMC that the digital link is affected by a failure.

In the case of a failed maintenance entity being detected, an automatic localization process is initiated. This process could localize the failure within the digital link by the use of loopbacks or subscriber access fault information.

TABLE 1/M.3604

Characteristics of the loopbacks for subscriber primary rate access

Loopback	Location	Channel(s) looped back	Loopback type	Control point	Control mechanism	Implementation
1	In LT, as near as possible to the line, towards the ET	Complete loopback (Note 3)	Non-transparent (Note 4)	ET or other NE within subscriber access	Local maintenance	Optional
1A	In the regenerator	Complete loopback (Note 3)	Non-transparent (Note 4)	ET or other NE within subscriber access	Layer 1	Optional
2	In NT1, as near as possible to T reference point, towards ET (Note 2)	Complete loopback (Note 3)	Non-transparent (Notes 1 and 4)	ET or other NE within subscriber access	Layer 1	Optional
3 ₁	In NT2, as near as possible to T reference point, towards T (Note 5)	B, H0, H1	Partial, transparent or non-transparent	Under control of local exchange	Layer 3	Optional
4	In the TE or TA	B, H0, H1	Partial, transparent or non-transparent	Under control of local exchange	Layer 3	Optional
E	In ET, towards the line	B, H0, H1	Partial, transparent or non-transparent	Under control of NT2 or TE/TA	Layer 3	Optional

Note 1 – When option 2 (see Annex A) is used, only the B- and D-channels are returned through the NT1 unaltered and therefore only those channels can be used by a loopback test.

Note 2 – In the case of using existing digital systems, a manual loopback may replace loopback 2. This loopback is implemented between NT2 and NT1 and is controlled by the user at the request of the network staff.

Note 3 – These complete primary rate loopbacks operate on the full bit stream including time slot 0 in 2048 kbit/s systems and the F bits of 1544 kbit/s systems.

Note 4 – These loopbacks are normally non-transparent and send AIS in the forward direction. However, when the network can continue to provide good network clock, these loopbacks may be transparent. When transparent loopbacks are used, the device at the loopback point must ensure that the forward signal meets any line code requirements. The test signal used with transparent loopbacks must include RAI and should, if possible (options 2 and 3 of 2048 kbit/s systems, see Annex A), indicate a fault within the network (frames are without continuous error reports).

Note 5 – Also see Table 2/M.3602 [11] for other loopbacks in the NT2.

Note 6 – A loopback within the ET towards the line may also be used as part of an ET self-test.

Note 7 – These layer 1 signals may not be in the frame signals. They may be line signals.

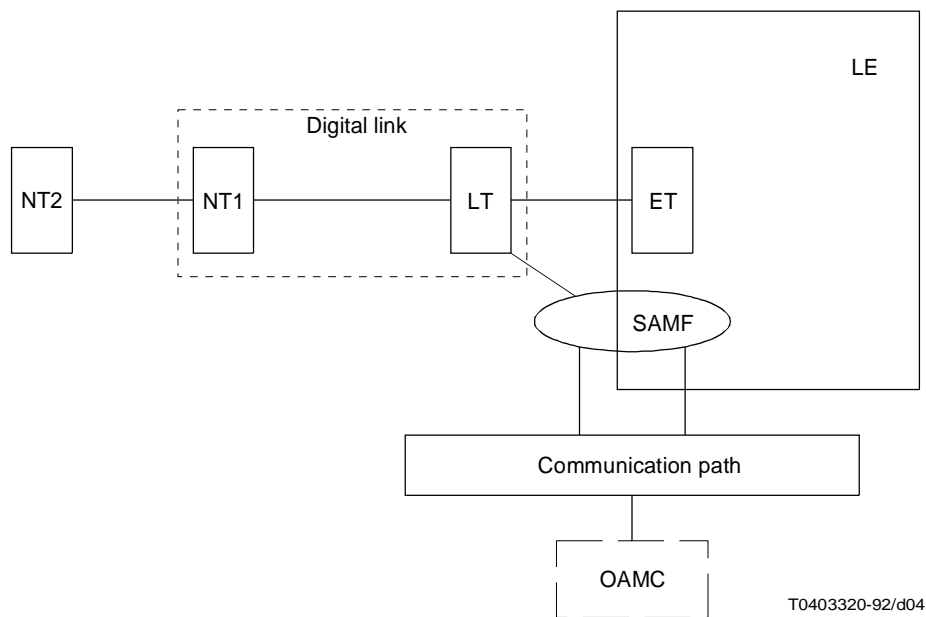

Note – SAMF may be distributed in different equipment.
See Recommendation M.3600 [2] for a detailed discussion.

FIGURE 4/M.3604
**Example of network architecture for the failure localization within
the subscriber primary rate link**

6.4.1 Initial failure localization performed by the ET and/or NT2 (TE)

The initial failure localization capability depends on the CRC option used in the network. For further information about different CRC options which may be applied in the access, see Annex A.

In general, CRC error information and fault indication signals may be used by either the NT2 or ET to deduce the location of some failures in operational conditions.

Failure localization in the case of option 2 refers to the capability to distinguish between a failure occurring either

- between NT2 and NT1; or
- between NT1 and ET.

Failure localization in the case of option 3 refers to the capability to distinguish between a failure occurring either

- between NT2 and NT1; or
- between NT1 and LT; or
- between LT and ET.

Failure localization in the case of option 4 refers to the capability to distinguish between a failure occurring either

- between NT2 and NT1; or
- between NT1 and ET.

This localization may be achieved by either the NT2 or the ET obtaining additional information from the NT1. The means to obtain this information is for further study.

6.4.1.1 *Failure localization performed by the NT2*

In options 2 and 3 the combination of CRC error information and RAI received from the interface allows the NT2 to localize a fault in the upstream direction of the access as follows:

- receipt of RAI by the NT2 with no, or a very small number of, reported CRC errors indicates a failure inside the network; or
- receipt of RAI by the NT2 with constantly, or a very high number of, reported CRC errors indicates a fault between NT2 and NT1.

This capability is not provided by option 1.

Concerning the downstream direction of the access, failure localization can be made in options 1, 2 and 3 by distinguishing between the following conditions at the receiving side of the NT2:

- AIS, indicating a fault inside the network; or
- loss of incoming signal or loss of frame alignment, indicating a failure between NT1 and NT2.

6.4.1.2 *Failure localization performed by the ET*

The failure localization capability of the ET depends on the CRC option used in the access, on the fault detection and reporting capability of the equipment installed and the provision of optional loopbacks as given in Table 1/M.3604. For further information about different CRC options applied in the access, see Annex A.

6.4.2 *Further failure localization*

For more precise localization, further techniques may be necessary, e.g. line parameter measurements.

This is for further study.

6.4.3 *Additional signals*

The use and definition of additional signals for transmission direction indication, extension of remote CRC reporting mechanisms and specific equipment signals is for further study.

7 Logistic delay time

See Recommendation M.20 [1].

8 Failure correction

See Recommendation M.20 [1].

9 Verification

The verification that the failure has been corrected is performed on demand of the staff.

Tests described in §§ 3, 6 and 11 may be used.

10 Restoration

After a failure has been cleared and the correct operation of the access verified (during which time the access will be in either the “out of service due to failure” or “degraded transmission” conditions), the access shall be returned into service. The mechanism/procedure (e.g. automatic or manual) for returning the access into service is not a subject of this Recommendation.

11 Overall performance measurements

Overall performance measurements could, from the point of view of the exchange

- concern a limited number of subscriber accesses at the same time;
- be made only on demand.

These tests and/or measurements shall not influence the conditions of the subscriber installation for incoming or outgoing calls. This gives the advantage of enabling measurement of the performance independently of the activity in the different channels of the subscriber access and also over a long period of time.

For the performance evaluation of a digital transmission system (over a long period of time) the administration network shall have arrangements for calculating the performance levels according to Recommendation M.2100 [3].

ANNEX A

(to Recommendation M.3604)

Subscriber access option

A.1 *Digital link without CRC processing (option 1)*

A.1.1 *Definition*

The transmission equipment (multiplexers, NT1-LT) used between the T and V interfaces (reference points) could be existing equipment which have standard functions of supervision and detection of defects and faults.

In this case, the digital link is said to be “without CRC processing”: the CRC procedure is between the ET and NT2 (see Figure A-1/M.3604).

A.1.2 *Digital link functions*

Functions allocated to the digital link are listed below:

- detection of loss of incoming signal on either side and inside the transmission section, and generation of AIS “downstream”;
- detection of AIS inside the transmission section and generation of AIS “downstream”;
- detection of defects and anomalies in the digital link.

A.1.3 *NT2 functions*

Functions allocated to the NT2 are given in § 3.2.2.

A.2 *Digital link with CRC processing in the NT1 (option 2)*

A.2.1 *Definition*

The transmission equipment used between the T and V interfaces (reference points) could be new equipment with CRC processing in the NT1 (see Figure A-2/M.3604). In this case, the digital link is said to be with “CRC processing in the NT1”.

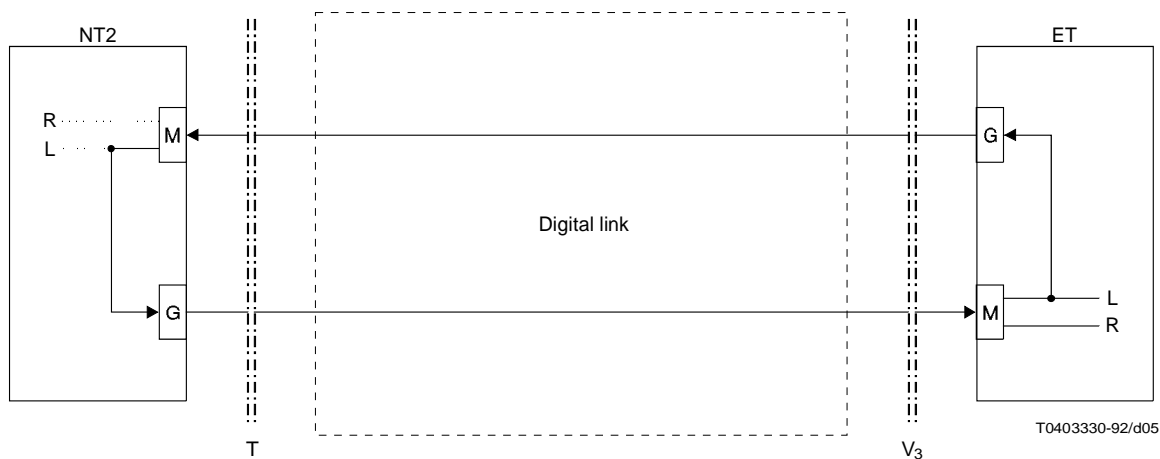

L Local CRC error information
 R Remote CRC error information
 M CRC monitor
 G CRC generator
 ————— Mandatory
 Optional

Note – CRC error reporting may require storage functions in the NT2 and ET.

FIGURE A-1/M.3604
Digital link without CRC processing

A.2.2 *Digital link functions*

Functions allocated to the digital link are listed below:

- detection of loss of signal at either side of the NT1 or inside the transmission section;
- detection of loss of frame alignment at either side of the NT1;
- generation of AIS downstream in the direction to the user;
- supervision of power supply (optional);
- CRC generation towards the user and towards the ET;
- CRC monitoring at both sides of the NT1 and detection of CRC blocks received with error;
- when a block with CRC error is received from NT2, transmission of CRC error information towards NT2 (Note);
- when a block with CRC error is received from ET, transmission of CRC error information towards ET;
- when a block with CRC error is received from ET, transmission of CRC error information towards NT2 (optional);
- detection of defect and anomaly in the digital link.

Note – To fulfill the requirement of failure localization, the NT1 has to report the CRC error information toward the NT2 even when loss of frame alignment has occurred. This is different from the procedure described in Recommendation G.706 [6].

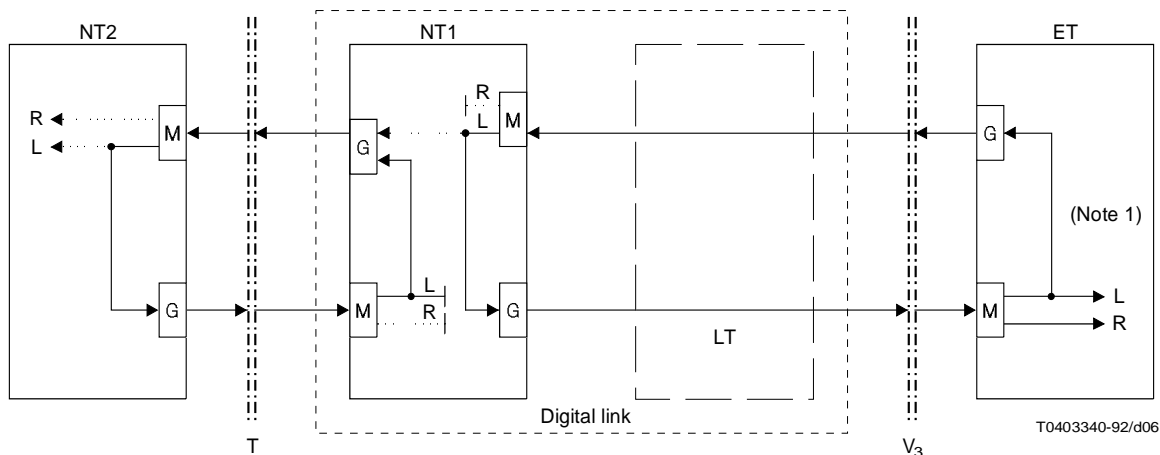

L Local CRC error information
 R Remote CRC error information
 M CRC monitor
 G CRC generator
 — Mandatory
 Optional

Note 1 – Optional in 1544 kbit/s systems.

Note 2 – CRC error reporting may require storage functions in the NT2, NT1 and ET.

FIGURE A-2/M.3604
Digital link with CRC processing in NT1

A.2.3 NT2 functions

Functions allocated to the NT2 are given in § 3.2.2.

A.3 Digital link with CRC processing in the LT and NT1 (option 3)

A.3.1 Definition

The transmission equipment used between the T and V interfaces (reference points) may be a new equipment with CRC processing, treatment and reporting of the results of that processing in the NT1 and LT (see Figure A-3/M.3604). In this case the digital link is said to be with “CRC processing and reporting in the NT1 and the LT”.

A.3.2 LT functions

Functions allocated to the LT are listed below:

- detection of loss of signal at either side of the LT;
- detection of loss of frame alignment at either side of the LT;
- detection of RAI at either side of the LT;
- generation of AIS downstream in the direction of the NT1;
- supervision of power supply (optional);
- generation of CRC towards NT1 and ET;
- monitoring of CRC from both sides of the LT and detection of CRC blocks received with error;

- when a block with CRC error is received from NT1, transmission of CRC error information toward NT1;
- when a block with CRC error is received from ET, transmission of CRC error information toward ET;
- when a block with CRC error is received from ET, transmission of CRC error information toward NT1 (optional);
- supervision of the numbers of CRC blocks received with error, from ET and from NT1 separately;
- checking thresholds corresponding to errored seconds and severely errored seconds;
- reporting errored seconds and severely errored seconds.

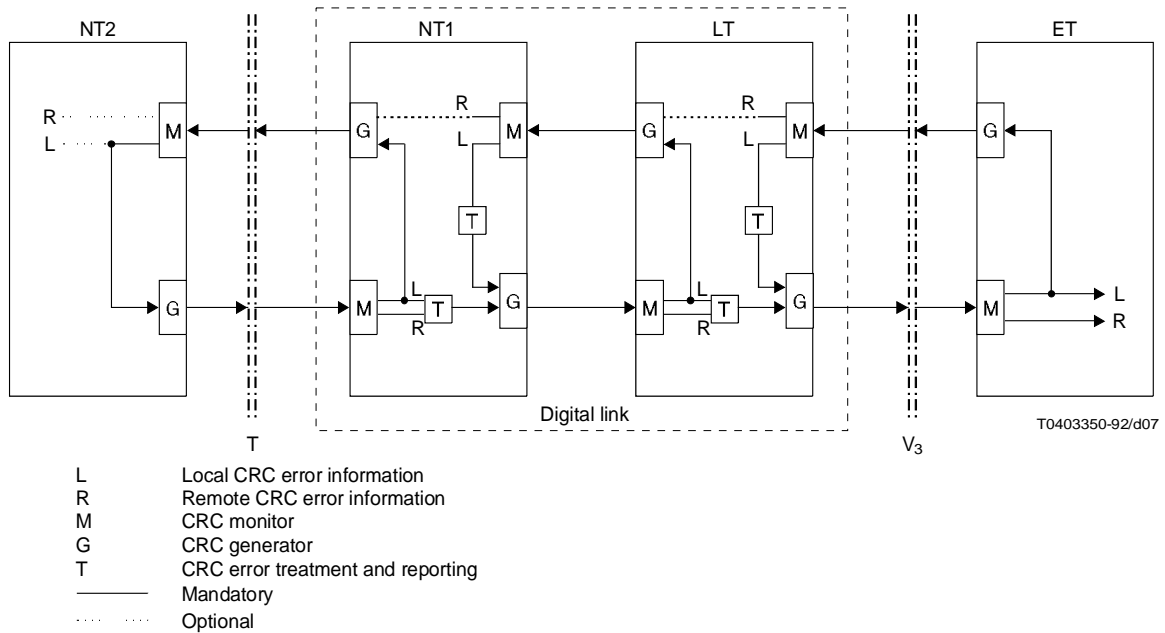

Note 1 – CRC error reporting may require storage and processing functions in NT2, NT1, LT and ET.

FIGURE A-3/M.3604
Digital link with CRC processing and reporting in the LT and NT1

A.3.3 NT1 functions

Functions allocated to the NT1 are listed below:

- detection of loss of signal at either side of the NT1;
- detection of loss of frame alignment at either side of the NT1;
- detection of RAI at either side of the NT1;
- generation of AIS downstream in the direction of the NT2;
- supervision of power supply (optional);
- generation of CRC towards NT2 and LT;

- monitoring of CRC from both sides of the NT1 and detection of CRC blocks received with error;
- when a block with CRC error is received from NT2, transmission of CRC error information toward NT2;
- when a block with CRC error is received from LT, transmission of CRC error information toward LT;
- when a block with CRC error is received from LT, transmission of CRC error information toward NT2 (optional);
- supervision of the numbers of CRC blocks received with error, from LT and NT2 separately;
- checking thresholds corresponding to errored seconds and severely errored seconds;
- reporting errored seconds and severely errored seconds.

A.4 Digital link with CRC monitoring in the NT1 (option 4)

A.4.1 Definition

The transmission equipment used between the T and V interfaces (reference points) could be new equipment with CRC monitoring in the NT1 (see Figure A-4/M.3604). In this case, the digital link is said to be “with CRC monitoring in the NT1”.

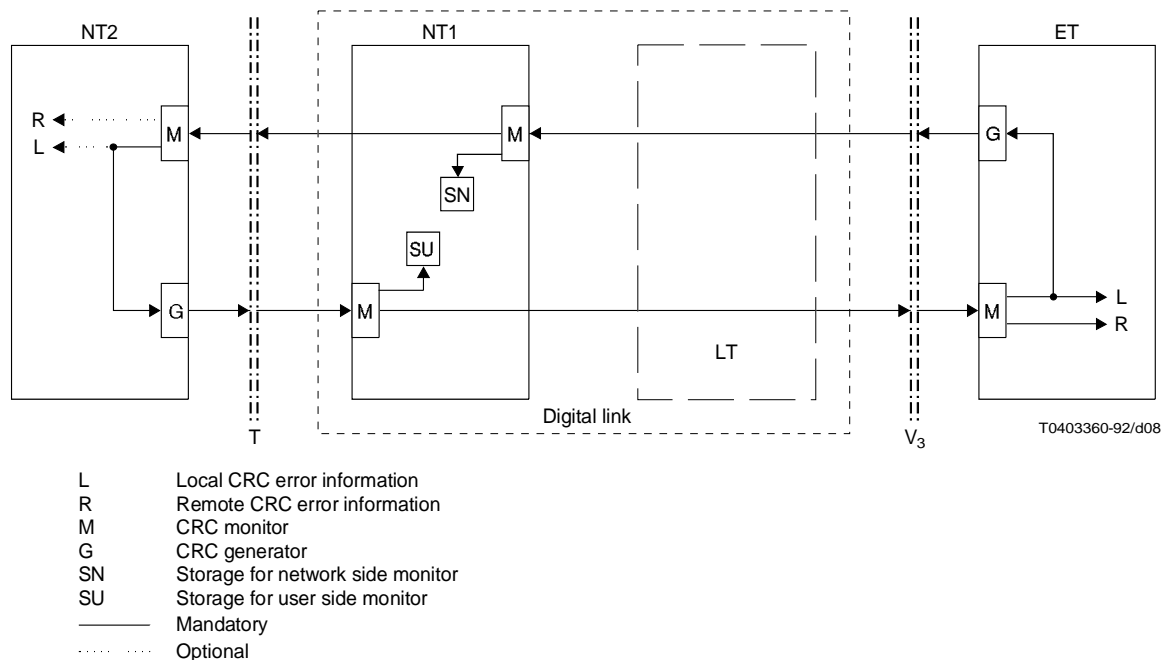

FIGURE A-4/M.3604
Digital link with CRC monitoring in NT1

A.4.2 NT1 functions

Functions allocated to the NT1 are listed below:

- detection of loss of signal or loss of frame alignment at either side;
- generation of AIS toward either side when signal or frame alignment on opposite side is lost;
- monitor CRC from both directions;
- store information derived from the CRC monitoring.

The information derived from the CRC monitoring and stored in the NT1 may be retrieved from either the NT2 or ET. The means for this retrieval is for further study.

A.4.3 NT2 function

In addition to the functions described in § 3.2.2, NT2s may also, optionally, have the capability of retrieving from the NT1 the stored information derived from CRC monitoring.

A.4.4 ET function

In addition to the functions described in § 3.2.3, ETs may also, optionally, have the capability of retrieving from the NT1 the stored information derived from CRC monitoring.

ANNEX B (to Recommendation M.3604) **Other network configurations**

B.1 Digital crossconnect system

A model introducing a new network element, the Digital Crossconnect System (DCS), in the simple access model is shown in Figure B-1/M.3604.

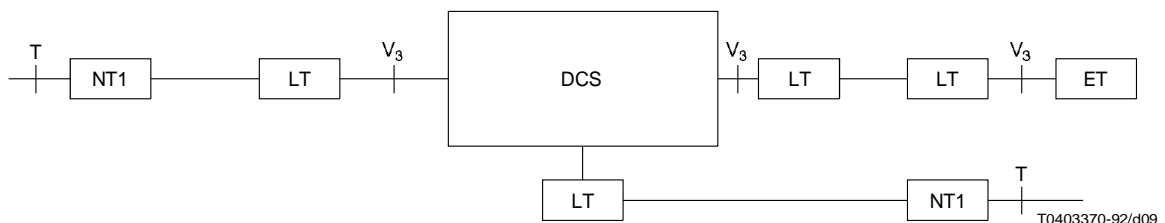

FIGURE B-1/M.3604
Primary rate access with DCS model

The DCS is a static crossconnect of B-channels, routing some to the exchange and some to the leased circuit network. Processing of the D-channel by the DCS is for further study, as discussed in Annex C.

This configuration requires additional maintenance procedures to be defined within either the ET or TMN controlling both the DCS and ET. These procedures are needed since failures that occur between V₃ and T are not visible at the ET and therefore the ET cannot take automatic actions to protect service. The procedures are for further study.

B.2 Primary rate leased circuit

In this case, all the B- and D-channels transverse the network from one NT2 to the other without being terminated on a network switch. The network simply provides transport for a private ISDN, as shown in Figure B-2/M.3604.



FIGURE B-2/M.3604
Leased circuit primary rate access model

Timing is provided by other arrangements. For example, timing may be provided by another interface to one of the NT2s.

ANNEX C

(to Recommendation M.3604)

Digital crossconnect system considerations for ISDN

DCSs may also process the D-channel. They may break the D-channel layer 2, so there are two tandem layer 2 links between the NT2 and the ET. The DCS routes layer 3 packets from the NT2 to either the exchange or leased network based on the routing of the associated B-channels. Thus, the DCS may also act as a packet crossconnect for the D-channel. However, the DCS does not perform switch functions. Its crossconnect function is controlled over a separate administrative link, not over the D-channel with Recommendation Q.931 [12] call control. This model also includes leased circuits. The B-channels traverse the network without terminating on a switch. The associated D-channel information can be carried in the leased network in the same digital paths as the B-channels or separately from the B-channels, on the CCSS No. 7 signalling network.

References

- [1] CCITT Recommendation M.20 *Maintenance philosophy for telecommunications network.*
- [2] CCITT Recommendation M.3600 *Principles for the maintenance of ISDNs.*
- [3] CCITT Recommendation M.2100 *Performance limits for bringing into service and maintenance of international digital paths, sections and transmission systems.*
- [4] CCITT Recommendation M.3640 *Management of the D-channel – Data link and network layer.*
- [5] CCITT Recommendation G.704 *Synchronous frame structures used at primary and secondary hierarchical levels.*
- [6] CCITT Recommendation G.706 *Frame alignment and cyclic redundancy check (CRC) procedures relating to basic frame structures defined in Recommendation G.704.*
- [7] CCITT G.700-Series Recommendations *General aspects of digital transmission systems; terminal equipment.*
- [8] CCITT G.900-Series Recommendations *Digital sections and digital line sections.*
- [9] CCITT Recommendation Q.512 *Exchange interfaces for subscriber access.*
- [10] CCITT Recommendation I.431 *Primary rate user-network interface – layer 1 specification.*
- [11] CCITT Recommendation M.3602 *Application of maintenance principles to ISDN subscriber installations.*
- [12] CCITT Recommendation Q.931 *ISDN user network interface layer 3 specification for basic call control.*