



INTERNATIONAL TELECOMMUNICATION UNION

**ITU-T**

TELECOMMUNICATION  
STANDARDIZATION SECTOR  
OF ITU

**M.3200**

(04/97)

SERIES M: TMN AND NETWORK MAINTENANCE:  
INTERNATIONAL TRANSMISSION SYSTEMS,  
TELEPHONE CIRCUITS, TELEGRAPHY, FACSIMILE  
AND LEASED CIRCUITS

Telecommunications management network

---

**TMN management services and  
telecommunications managed areas: overview**

ITU-T Recommendation M.3200

(Previously CCITT Recommendation)

---

ITU-T M-SERIES RECOMMENDATIONS

**TMN AND NETWORK MAINTENANCE: INTERNATIONAL TRANSMISSION SYSTEMS, TELEPHONE  
CIRCUITS, TELEGRAPHY, FACSIMILE AND LEASED CIRCUITS**

Introduction and general principles of maintenance and maintenance organization	M.10–M.299
International transmission systems	M.300–M.559
International telephone circuits	M.560–M.759
Common channel signalling systems	M.760–M.799
International telegraph systems and phototelegraph transmission	M.800–M.899
International leased group and supergroup links	M.900–M.999
International leased circuits	M.1000–M.1099
Mobile telecommunication systems and services	M.1100–M.1199
International public telephone network	M.1200–M.1299
International data transmission systems	M.1300–M.1399
Designations and information exchange	M.1400–M.1999
International transport network	M.2000–M.2999
<b>Telecommunications management network</b>	<b>M.3000–M.3599</b>
Integrated services digital networks	M.3600–M.3999
Common channel signalling systems	M.4000–M.4999

*For further details, please refer to ITU-T List of Recommendations.*

## **ITU-T RECOMMENDATION M.3200**

### **TMN MANAGEMENT SERVICES AND TELECOMMUNICATIONS MANAGED AREAS: OVERVIEW**

#### **Summary**

This Recommendation provides an overview of the M.3200-Series. It describes the structuring principles of the M.3200-Series and lists the currently agreed Recommendations.

The concepts of "Telecommunications Managed Area" and "Telecommunications Management" are introduced. A summary description of each is provided, as well as a matrix defining their relationships. These Recommendations are intended as the basis for the corresponding modelling and protocol work on the TMN interfaces. They also provide a basis from which an Administration might plan the evolution of its Telecommunications Management as defined in 3.2 of this Recommendation.

The Recommendation is completed through a summary of a hypothetical example of the management context of a matrix crosspoint, i.e. Maintenance Management of Switched Telephone Network.

#### **Source**

ITU-T Recommendation M.3200 was revised by ITU-T Study Group 4 (1997-2000) and was approved under the WTSC Resolution No. 1 procedure on the 19th of April 1997.

#### **Keywords**

Object Modelling, Telecommunications Managed Areas, Telecommunications Management, Telecommunications Management Network, Management Service, Task Information Base.

## FOREWORD

ITU (International Telecommunication Union) is the United Nations Specialized Agency in the field of telecommunications. The ITU Telecommunication Standardization Sector (ITU-T) is a permanent organ of the ITU. The ITU-T is responsible for studying technical, operating and tariff questions and issuing Recommendations on them with a view to standardizing telecommunications on a worldwide basis.

The World Telecommunication Standardization Conference (WTSC), which meets every four years, establishes the topics for study by the ITU-T Study Groups which, in their turn, produce Recommendations on these topics.

The approval of Recommendations by the Members of the ITU-T is covered by the procedure laid down in WTSC Resolution No. 1.

In some areas of information technology which fall within ITU-T's purview, the necessary standards are prepared on a collaborative basis with ISO and IEC.

## NOTE

In this Recommendation, the expression "Administration" is used for conciseness to indicate both a telecommunication administration and a recognized operating agency.

## INTELLECTUAL PROPERTY RIGHTS

The ITU draws attention to the possibility that the practice or implementation of this Recommendation may involve the use of a claimed Intellectual Property Right. The ITU takes no position concerning the evidence, validity or applicability of claimed Intellectual Property Rights, whether asserted by ITU members or others outside of the Recommendation development process.

As of the date of approval of this Recommendation, the ITU had/had not received notice of intellectual property, protected by patents, which may be required to implement this Recommendation. However, implementors are cautioned that this may not represent the latest information and are therefore strongly urged to consult the TSB patent database.

© ITU 1997

All rights reserved. No part of this publication may be reproduced or utilized in any form or by any means, electronic or mechanical, including photocopying and microfilm, without permission in writing from the ITU.

## CONTENTS

	<b>Page</b>
1 Scope.....	1
2 References.....	1
2.1 CCITT and ITU-T Recommendations .....	1
2.2 ITU-R Recommendation.....	2
3 Definitions .....	2
4 Abbreviations.....	3
5 Telecommunications Managed Areas.....	4
5.1 Switched Telephone Network.....	4
5.2 Mobile Communications Network.....	5
5.3 Switched Data Network .....	5
5.4 Intelligent Network.....	6
5.5 Common Channel Signalling System No. 7 Network .....	6
5.6 N-ISDN .....	7
5.7 B-ISDN .....	8
5.8 Dedicated and Reconfigurable Circuits Network.....	8
5.9 TMN.....	8
5.10 IMT-2000 (formerly FPLMTS) .....	9
5.11 Access and Terminal Equipment Network .....	10
5.12 Transport Network.....	10
5.13 Infrastructure.....	10
6 TMN Management Services .....	10
6.1 Customer Administration.....	11
6.2 Network Provisioning Management .....	11
6.3 Work Force Management .....	12
6.4 Tariff, Charging and Accounting Management.....	12
6.5 Quality of Service and Network Performance Management.....	12
6.6 Traffic Measurements and Analysis Administration.....	13
6.7 Traffic Management.....	13
6.8 Routing and Digit Analysis Administration .....	13
6.9 Maintenance Management.....	14
6.10 Security Administration.....	14
6.11 Logistics Management.....	14

	<b>Page</b>
7	Management Services × Telecommunications Managed Areas Matrix ..... 15
7.1	Relationship between this Recommendation and Recommendation M.3020 ..... 15
7.2	M.3200-Series..... 16
8	Relationships between TMN Management Services and existing Recommendations 16
	Appendix I – Example of GDMS application..... 16
I.1	Management Service Description ..... 17
I.2	Management goals ..... 17
I.3	Management Context Description ..... 17
	I.3.1 Dynamic view of Management Context..... 17
	I.3.2 Resources..... 17
	I.3.3 Roles ..... 18
	I.3.4 TMN Management Functions Sets and Set Groups ..... 19
I.4	Architecture..... 19
I.5	Scenarios ..... 21

## **Recommendation M.3200**

### **TMN MANAGEMENT SERVICES AND TELECOMMUNICATIONS MANAGED AREAS: OVERVIEW**

*(1992; revised in 1997)*

#### **1 Scope**

This Recommendation is intended to provide an overview of Telecommunications Management Network (TMN) Management Services and Telecommunications Managed Areas. It provides the framework for the specification of protocols, messages, management information, etc. for TMN interfaces. The TMN Management Services are described from the TMN users' perspective and are independent of the protocols, messages and information models chosen. They will therefore assist in the smooth transition from a non-TMN to a TMN environment.

It should be noted that flexibility will be required in the definition of TMN Management Services to enable additional requirements to be accommodated as they are identified.

To avoid discrepancies and duplications, this Recommendation establishes the structuring principles (e.g. numbering, naming, etc.) for the M.3200-Series of Recommendations.

#### **2 References**

The following ITU-T Recommendations and other references contain provisions which, through reference in this text, constitute provisions of this Recommendation. At the time of publication, the editions indicated were valid. All Recommendations and other references are subject to revision; all users of this Recommendation are therefore encouraged to investigate the possibility of applying the most recent edition of the Recommendations and other references listed below. A list of the currently valid ITU-T Recommendations is regularly published.

##### **2.1 CCITT and ITU-T Recommendations**

- E.410 through E.414, *International network management*.
- E.420 through E.428, *Checking the quality of the international telephone service*.
- E.500 through E.721, *Traffic engineering*.
- E.800 through E.880, *Quality of telecommunication services: concepts, models, objectives, dependability planning*.
- ITU-T Recommendation M.3010 (1996), *Principles for a telecommunications management network*.
- ITU-T Recommendation M.3020 (1995), *TMN interface specification methodology*.
- ITU-T Recommendation M.3100 (1995), *Generic network information model*.
- ITU-T Recommendation M.3400 (1997), *TMN management functions*.
- CCITT Recommendation Q.500 (1988), *Digital local, combined, transit and international exchanges, introduction and field of application*.
- ITU-T Recommendation Q.512 (1995), *Digital exchange interfaces for subscriber access*.
- ITU-T Recommendation Q.513 (1993), *Digital exchange interfaces for operations, administration and maintenance*.

- ITU-T Recommendation Q.521 (1993), *Digital exchange functions*.
- ITU-T Recommendation Q.541 (1993), *Digital exchange design objectives – General*.
- ITU-T Recommendation Q.542 (1993), *Digital exchange design objectives – Operations and maintenance*.
- ITU-T Recommendation Q.750 (1997), *Overview of Signalling System No. 7 management*.
- ITU-T Recommendation Q.751.1 (1995), *Network element management information model for the Message Transfer Part*.
- ITU-T Recommendation Q.752 (1997), *Monitoring and measurements for Signalling System No. 7 networks*.
- ITU-T Recommendation Q.753 (1997), *Signalling System No. 7 management functions MRVT, SRVT and CVT and definition of the the OMASE-user*.
- ITU-T Recommendation Q.754 (1997), *Signalling System No. 7 management Application Service Element (ASE) definitions*.
- ITU-T Recommendation Q.821 (1993), *Stage 2 and stage 3 description for the Q3 interface – Alarm surveillance*.

## 2.2 ITU-R Recommendation

- M.817, *Basic Functional Model for IMT-2000*.

## 3 Definitions

This Recommendation defines the following terms.

**3.1 telecommunications managed area:** Telecommunications Managed Area is a set of telecommunications resources, logically and/or physically involved with the telecommunications services, that makes it possible to provide, partly or completely, these services to the customers and is chosen to be managed as a whole.

Examples: Switched Data Network

Switched Telephone Network

**3.2 telecommunications management:** Telecommunications Management, overall, is the result of integrating the management of the several Telecommunications Managed Areas of a company in order to maximize the quality to the telecommunications customers and the telecommunications resources productivity of a specific company, through performing the Management Services needed. The business objective of Telecommunications Management is to continually improve quality to the customer and operational productivity. Measures of continual improvement include:

- faster response to customers services demand;
- faster elimination of root causes of productivity degradation;
- improved accuracy of the bills and faster reception of them.

The objectives of Management Services are to support, through re-engineered processes and automation, these business objectives.



## 4 Abbreviations

This Recommendation uses the following abbreviations:

AAL	ATM Adaptation Layer
ADM	Add-Drop Multiplex
ASE	Application Service Element
ATM	Asynchronous Transfer Mode
BS	Base Station
FPLMTS	Future Public Land Mobile Telephone System
HTR	Hard-to-Reach
IDF	Intermediate Distribution Frame
IMT-2000	International Mobile Telecommunications-2000
IP	Intelligent Peripheral
ISUP	ISDN User Part
ME	Maintenance Entity
MIL-STD	Military Standard
MS	Mobile Station
MSC	Mobile Switching Centre
MTBF	Mean Time Between Failures
MTP	Message Transfer Part
OMAP	Operations, Maintenance, Administration and Provisioning
QOS	Quality of Service
RBS	Radio Base Stations
SCCP	Signalling Connection Control Part
SCE	Switching and Control Exchanges
SCP	Service Control Point
SDH	Synchronous Digital Hierarchy
SMDS	Switched Multimegabyte Digital System
SPC	Stored Program Control
SP	Signalling Points
SSP	Service Switching Point
STP	Signalling Transfer Points
TUP	Telephone User Part
VOD	Voice on Demand

## **5 Telecommunications Managed Areas**

Although almost all the Managed Area names have the word "Network" attached to them, the management requirements must include Business, Service, Network and Network Element management needs. The boundaries established through 5.1 up to 5.13 do not exclude the need of the integration established in the definition of Telecommunications Management, given in clause 3. The following are examples of the needed integration:

- a) All Telecommunications Services use resources of: Access and Terminal Equipment Network, Transport Network and Infrastructure.
- b) Packet Switched Data Services use Switched Telephone Network as part of their access.
- c) Freephone (e.g. 800 Service) use IN, Switched Telephone Network and ISDN resources to be accomplished.
- d) Cellular Telephone Services are highly integrated with Switching Telephone Services.

The management integration of the different Managed Areas and Management Services, within the OS's of a given TMN, is not subject of standardization.

A Telecommunications Managed Area can range from a single piece of telecommunications equipment up to a very complex network. Depending on its network complexity, each company will organize its Telecommunications Management in a different way. This means that there is no standard to define which will be the Telecommunications Managed Areas of a specific company, when considered from a Management standpoint. The list below is a possible example.

### **List of Telecommunications Managed Areas**

- 1) Switched Telephone Network;
- 2) Mobile Communications Network;
- 3) Switched Data Network;
- 4) Intelligent Network;
- 5) Common Channel Signalling System No. 7 Network;
- 6) N-ISDN;
- 7) B-ISDN;
- 8) Dedicated and Reconfigurable Circuits Network;
- 9) TMN;
- 10) IMT-2000 (formerly FPLMTS);
- 11) Access and Terminal Equipment Network;
- 12) Transport Network;
- 13) Infrastructure.

NOTE – The above list is intended to apply to public and private networks. It is not intended to be exhaustive. Further revisions of this Recommendation may have additions.

### **5.1 Switched Telephone Network**

The Switched Telephone Network is the set of telephone exchanges or telephone switching nodes or simply switches that support the telephone service. These are switched circuit nodes. Nowadays, a number of different voice and data services flow through the Switched Telephone Network. To

exemplify, we can mention circuit switched access to: Packet Switched Data Network, Fax, Intelligent Network Services, etc.

The distribution frames do not belong to the Switched Telephone Network. They are part of Access and Terminal Equipment Network or part of the Transport Network. The boundaries of the exchanges are the switching part connected to the transmission facilities. The physical resources that constitute an exchange can receive different names, depending on the manufacturer, but there are some common designations such as: incoming trunks, outgoing trunks, registers, senders, receivers, switching matrix, controllers, markers, signalling bus, O&M, etc. The same happens when we consider the logical resources. There is a trend for the exchanges to be more and more software-based. The set of software modules depends on the exchange architecture that can be more or less distributed. Independent from the physical or logical architecture, there is a number of common functionalities, needed for call routing, transmission, signalling, charging and management, etc.

The exchanges that are connected to the Access and Terminal Equipment Network are called Local Exchanges. The switching nodes used to interconnect other switches are called tandem or transit switches. The exchanges can be analogue or digital, depending on the nature of the switched signal. A number of different technologies have been applied in the field and among them we can mention: Step-by-Step, Rotary, Crossbar, Crosspoint, Analogue-SPC (Stored Program Controlled) and Digital-SPC.

## **5.2 Mobile Communications Network**

The Mobile Communications Network is the set of dedicated or non-dedicated switching nodes and some associated RBS (Radio Base Stations or Cell Sites) needed for providing voice and data Mobile Services. In the case of non-dedicated nodes, they are part of the switched network involved.

The switching nodes associated with Mobile Services are usually named Switching and Control Exchanges (SCE) and as they are digital equipment they should be connected to the Switched Telephone Network by digital links (e.g. PCM, fibre-optics, etc.). The RBS cover a limited physical area or region known as "CELL". The roaming signalling and handoff resources belong to this managed area.

Depending on the adopted technology for the Mobile Communications Network, the connection between SCE and RBS may use optical fibre or radio links. The RBS should use radio links to connect themselves to mobile stations. There is a limited number of radio frequencies available for each RBS.

## **5.3 Switched Data Network**

The Switched Data Network is the set of switching nodes needed for the Data Switching Business. The distributing frames do not belong to Data Switched Network. They are part of Access and Terminal Equipment Network or part of the Transport Network. The boundaries of the nodes are the switching part connected to the transmission facilities. The physical resources that constitute a node can receive different names, depending on the manufacturer, but Processor Element (PE) and Peripheral Interface (PI) are somewhat common designations. The same happens when we consider the logical resources. Most of the capabilities are software-implemented. The set of software modules depends on the node manufacturer, although most of them have adopted a distributed architecture. Independent from the physical or logical architecture, there is a number of common capabilities, because of the commonality in services. For instance, we can mention the following access services and protocols:

ITU-T Recommendations X.25, X.32, X.75, X.28, X.29, ISDN (X.31) and frame relay.

## 5.4 Intelligent Network

Intelligent Network (IN) is an architectural concept for the operation and provision of new services which is characterized by:

- centralized service logic;
- extensive use of information processing techniques;
- efficient use of network resources;
- modularization and reusability of network functions;
- integrated services creation and implementation by means of modularized reusable network functions;
- flexible allocation of network functions to physical entities;
- portability of network functions among physical entities;
- standardized communication between network functions via service independent interfaces;
- some user-specific service attributes that can be controlled by the users themselves;
- some subscriber-specific service attributes that can be controlled by the subscribers themselves;
- standardized management of service logic.

IN is applicable to a wide variety of networks, including but not limited to: switched telephone network, mobile communications network, switched data network and integrated services digital network. IN supports a wide variety of services such as: freephone, calling credit card, and virtual private network, and utilizes bearer services.

The design and description of the IN architecture have a framework given by its IN Conceptual Model, which consists of four abstract view planes: Service plane, Global Functional plane, Distributed Functional plane and Physical plane. IN physical architecture is based upon building blocks such as Service Control Point (SCP), Service Switching Point (SSP), Intelligent Peripheral (IP), etc.

## 5.5 Common Channel Signalling System No. 7 Network

Common Channel Signalling System (CCSS) No. 7 Network is a signalling network interconnecting Signalling Points (SP) and Signalling Transfer Points (STP), by means of signalling link-sets. The SPs are the originating and destination points. The STPs act as transit exchanges for signalling purposes. A link set is a number of signalling links that directly interconnect two signalling points. A group of links within a link-set that have identical characteristics is called a link group. All these resources are normally within the telephone exchanges and the transport network, and through them the CCSS is optimised for operation in digital telecommunication networks with stored program controlled (SPCs) exchanges. They form a special signalling network that can support applications such as: PSTN, ISDN, Interaction with Network Databases, Intelligent Network, Public Land Mobile Network and Telecommunications Management Network (TMN). Common Channel Signalling System No. 7 can be regarded as a form of switched data network, which is specialised for various types of application and information transfer between processors in the telecommunications network.

The logical resources are the implementation of the functional blocks, as shown in Figure 1. The term "users" in this figure refers to any functional entity that utilises the transport capability provided by the Message Transfer Part. Only the resources dedicated to MTP and SCCP belong to CCSS. The physical and logical resources do not belong to CCSS and are covered by the other blocks of the related Telecommunications Managed Areas.

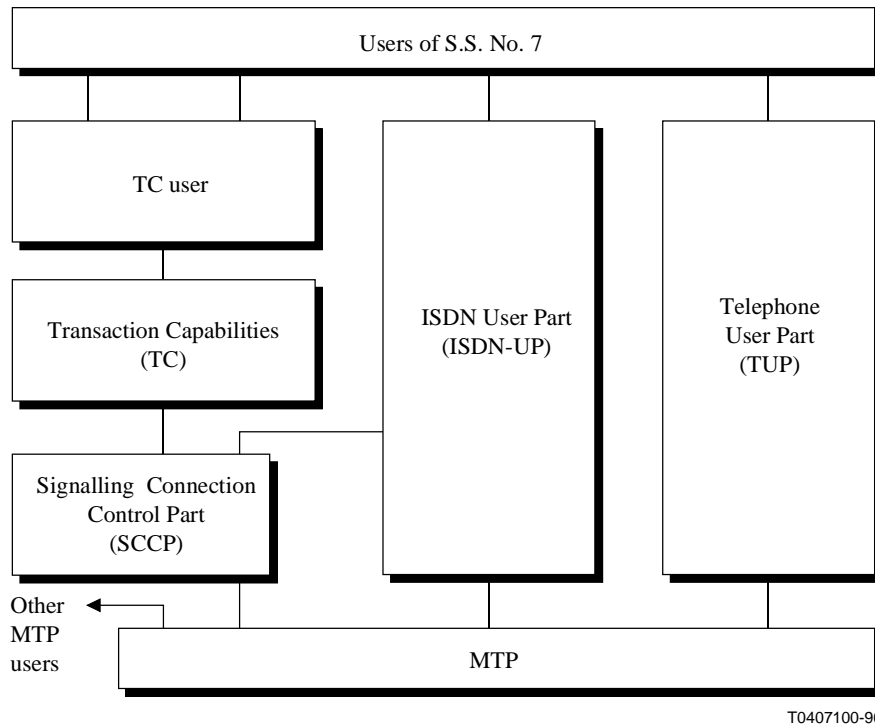

**Figure 1/M.3200 – Architecture of S.S. No. 7**

## 5.6 N-ISDN

N-ISDN is a narrow-band integrated services network that has evolved from the Public Switched Telephone Network (PSTN), and provides digital connections between user-network interfaces in support of a range of different telecommunications services, maintenance and network management functions. Figure 2 presents the basic concept of ISDN architecture.

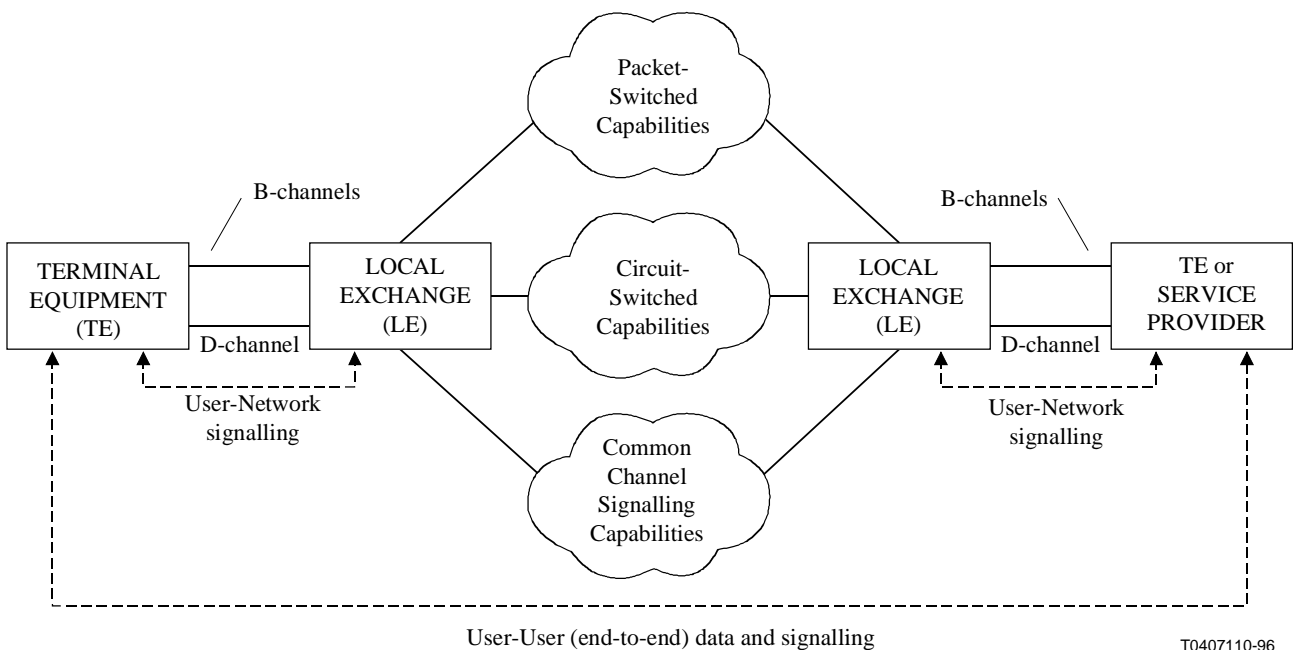

**Figure 2/M.3200 – Basic concept of ISDN architecture**

The terminal equipment, network terminations and connections to the exchange do not belong to N-ISDN Managed Area. They are part of Access and Terminal Equipment Network. Packet/Circuit Switched Capabilities and MTP of the Common Channel Signalling Capability are also outside the scope of N-ISDN, since they are covered by specific Managed Areas, but logical and physical resources, dedicated to ISUP, belong to N-ISDN.

Specific functionalities of N-ISDN include:

- User-network signalling control;
- Activation/Deactivation progress control;
- Messages exchanged and processed through Embedded Operation Channel (EOC);
- Handling of interactive types of data communication through the use of D-channel;
- Handling of simultaneous speech and data services on a single line.

## **5.7 B-ISDN**

B-ISDN is a concept of switched integrated network to transport different kinds of Telecommunication services (voice, data, image and video) in a standard digital format through fixed length cells (53 bytes), based mainly on SDH and ATM technologies.

The integration of different services is possible through ATM Adaptation Layers (AALs) that allow different kinds of services to be adapted and transmitted in the same cell format. Part of the services that can be integrated through the B-ISDN are, for instance, LAN, SMDS, Frame Relay and Multimedia Services (VOD, Telecommuting, Telemedicine, desk-top publishing, etc.)

The equipment used in B-ISDN includes ATM concentrators and ATM nodes that perform adaptation or switching functions, depending on its capabilities. The adaptation of existing services can also be performed outside concentrators through network terminals and terminal adapters that are not included in B-ISDN Managed Area because they belong to the Access and Terminal Equipment Network.

The offered services that need Servers (VOD, SMDS, etc.) are usually provided by Servers Systems that, because of their architectural concept, belong to Intelligent Network. The Transport Network of B-ISDN can be built up of SDH technology and uses the regular transmission means and equipment between nodes and concentrators (IDF, ADM, etc.), which can not be included in B-ISDN because they belong to the Transport Network.

## **5.8 Dedicated and Reconfigurable Circuits Network**

The Dedicated and Reconfigurable Circuits Network is a set of Leased and Special Circuits resources necessary for voice, data, image and video communication in a customized network.

This network can be reconfigured and managed by the customer and/or by the operator.

Part of the network elements that composes this network is already covered by resources of other Managed Areas such as Transport Network and Access and Terminal Equipment Network, which are not included in this managed area. Resources such as routers and bridges can be dedicated to this area, as we can find, for instance, in networks that uses X.50 or X.51 protocols.

## **5.9 TMN**

TMN is the network which supports management activities associated with telecommunication networks in order to fulfil the requirements to plan, provision, install, maintain, operate and administer telecommunication networks and services.

TMN provides an organized architecture that allows the necessary interconnection among various types of Operation Systems and/or telecommunication equipments. TMN must provide a high degree of flexibility to meet the various topological conditions of the telecommunications network itself and the organization of the administration.

There are three basic TMN architectures that should be considered: functional, information and physical. The TMN functional architecture provides the means to transport and process information related to the management of telecommunication networks. It is based on a number of function blocks which enables TMN to perform the TMN management functions.

The TMN information architecture is basically an object-oriented approach for information exchanges. The TMN physical architecture is based upon building blocks such as Operation Systems (OS), Mediation Devices (MD), Q Adaptor (QA), Data Communication Network (DCN), Network Element (NE) and Workstations (WS).

The exchange of information between blocks is made possible through the implementation of interoperable interfaces concept and the use of TMN standard interfaces such as Q3, Qx, F and X.

The TMN is logically distinct from the networks and services being managed, which allows operators to perform management of a wide range of distributed equipment, networks and services from a number of management systems.

It is also possible to interconnect different TMNs.

### **5.10 IMT-2000 (formerly FPLMTS)**

IMT-2000 (International Mobile Telecommunications-2000) (formerly FPLMTS) is the third generation of mobile telecommunications system which aims at providing global service portability by means of Personal Mobility (PM), Terminal Mobility (TM) and Service Mobility (SM).

It will provide access, by means of one or more radio links, to a wide range of telecommunication services supported by the fixed telecommunication networks, and to other services which are specific to mobile users.

Key features of IMT-2000 are high degree of commonality of design worldwide, compatibility of services within IMT-2000 and with the fixed networks, high quality, and use of a small pocket-terminal with worldwide roaming capability.

IMT-2000 may be implemented as a stand-alone network with gateways and interworking units connecting it to the supporting networks, in particular PSTN, ISDN, and B-ISDN.

It may also be integrated with the fixed networks by means of other networks.

The physical architecture for IMT-2000 is based on several building blocks such as: Mobile Station (MS), Base Station (BS) and Mobile Switching Centre (MSC). The Mobile Station belongs to the Access and Terminal Equipment Network. The Base Station (BS) belongs to IMT-2000 and the Mobile Switching Centre (MSC) belongs to IMT-2000 when dedicated exclusively to it.

The basic functional model outlines the types of functional entities required to provide IMT-2000 services irrespective of environment (microcells, macrocells, satellite spots, etc.). The model also shows the functional relationships between these functional entities.

The basic functional model for IMT-2000 can be found in ITU-R Recommendation M.817. All the logical resources, dedicated to implement this model, belong to IMT-2000.

### **5.11 Access and Terminal Equipment Network**

Access and Terminal Equipment Network is the part of the local network that extends from the network terminating equipment up to, and including, the exchange termination. This must take into account any equipment associated with the customer access including multiplex equipment, network terminating units etc., regardless of whether they are narrowband or broadband, analogue or digital and must include terminal equipment.

Because of its complexity, Access and Terminal Equipment Network can no longer be regarded as consisting of copper wires and network terminating equipment. It may now consist of copper wires or optical fibre or radio links along with complex electronic equipment whose functions may need to be updated or changed by the network provider.

### **5.12 Transport Network**

Transport Network is the set of transmission paths linking two distributing frames, to which terminal equipments or switching nodes are connected. The transmission means used to connect the terminal equipments with the distributing frame are not included in the Transport Network because they belong to the Access and Terminal Equipment Network. The equipments used in Transport Network can be analogue or digital and can include multiplexers, line transmitters/receivers, transponders, radios, repeaters/regenerators, satellites, echo cancellors/suppressors, etc. The Transport Network provides the transmission means to all telecommunications services and networks, such as PSTN, PSPDN, VSAT, IN, CCSS, Cellular, etc. This means that within each transmission path, we can have telephone circuits, data circuits, TV channels, CCSS channels, etc. The main technologies used to build the Transport Network are FDM, PDH, SDH, copper wires, coaxial cables, optical cables, satellite, digital cross-connect and ATM.

The Transport Network can also be considered as a set of trails. The trail is a "transport entity", in a server layer, responsible for the integrity of transfer of "characteristic information" from one or more client network layers, between server layer "access points". It defines the association between "access points" in the same "transport network layer". It is formed by combining a near-end "trail termination" function, a "network connection" and a far-end "trail termination" function. Trail termination functions provide information related to the integrity of information transfer in a trail. In SDH, a trail could be defined as a lower-order path or a higher-order path. Adaptation functions could be done by a digital multiplex and connection functions by a digital cross-connect. In PDH, a trail could be defined as a path. Adaptation functions could be done by a multiplex or a line system. In ATM, a trail could be defined as virtual channel or a virtual path.

### **5.13 Infrastructure**

Infrastructure Managed Area is the set of resources not directly involved in the telecommunications services, although that set supports all telecommunications services. Infrastructure includes resources such as: buildings, air conditioning, access roads, power plant, etc.

## **6 TMN Management Services**

TMN Management Service is defined in Recommendation M.3020. The interface requirements for TMN Management Service are the result of performing Task 1 and Task 2 of the interface specification methodology, using the GDMS, which are documented in Recommendation M.3020. The TMN Management Services are the support for the management of a certain Telecommunication Managed Area.



The list of Management Services which have been identified is presented below. The Functions and/or Management Function Sets used to accomplish each of these Management Services belong to some or to all Management Functional Areas presented in Recommendation M.3400.

### **List of Management Services**

- 1) Customer Administration;
- 2) Network Provisioning Management;
- 3) Work Force Management;
- 4) Tariff, Charging and Accounting Administration;
- 5) Quality of Service and Network Performance Administration;
- 6) Traffic Measurement and Analysis Administration;
- 7) Traffic Management;
- 8) Routing and Digit Analysis Administration;
- 9) Maintenance Management;
- 10) Security Administration;
- 11) Logistics Management.

The above list is only meant as a guide and is not intended to be exhaustive. Further revisions of this Recommendation may have additions.

NOTE 1 – This list of TMN Management Services should be refined with the help of the Working Parties and Study Groups which have expertise in specific areas covered by these TMN Management Services (e.g. in Study Groups 2, 4, 11, 15).

NOTE 2 – Some TMN Management Services which are identified above may be too large in scope to be treated as a single service. The possible subdivision of these services is for further study.

Management Services are supported by interactions across all TMN Interfaces (X, F and Q) unless explicitly noted otherwise for a given Management Service.

The following Management Service descriptions are prose descriptions intended to capture the overall telecommunications processes involved for each. These descriptions are not detailed and it is expected that individual recommendations, addressing these Management Services, provide, as reference, detailed requirement and processes directed by Recommendation M.3020.

#### **6.1 Customer Administration**

Customer Administration is a management activity that the network operator performs in order to exchange with the customer management data and functions required to offer a telecommunications service and to exchange with the network all the customer-related management data and functions necessary for the network to produce that telecommunications service. This could include interactions for the purpose of Service Provision Management, Configuration Administration, Fault Administration, Charging (including detailed billing) Administration, Complaints Administration, Quality of Service Administration, Traffic Measurement Administration etc. Here, however, only Customer Administration in the more traditional sense of service provisioning, service configuration and complaints management has been included.

#### **6.2 Network Provisioning Management**

Everyday, new customers in a telecommunication Administration demand several telecommunication services. The minimum time to respond, from the customers' standpoint, should be calculated when all the needed facilities are available at the nearest point to customers' premises.

The length of time needed depends on how proactive is the telecom Administration in providing all the network facilities. The process starts with the Strategic Planning and continues up to the installation of the needed resources for the traditional services and for those created proactively. The goal of this Management Service is to provide the most cost-effective network possible and the most competitive set of services, new and traditional, through the available network resources.

### **6.3 Work Force Management**

The history of telecommunication operations shows examples of how actions and omissions of technical people can cause small and catastrophic productivity degradations. Trouble-ticket data processing is needed to obtain very important information to enhance human resources development in order to avoid or reduce such undue actions and omissions. Besides, the quality of telecommunication services offered to customers depends very much on the network operator's staff. Although this Management Service has no direct influence on Network Elements, it should be considered that effective staff work scheduling helps to keep the staff effort at an economic level.

Accordingly, staff work scheduling is a management activity of the network operator in order to facilitate dispatching the appropriate staff member for the work to be performed. This is valid not only for OAM of the NEs, but also for the maintenance and installation work to be carried out at the customers' premises. Furthermore, the staff has to be scheduled for installation or repair work in the field, e.g. for cables, microwaves, etc.

### **6.4 Tariff, Charging and Accounting Management**

Every time a new telecommunication service is created, a corresponding change/addition should be made in tariff, charging and accounting. Every month, or every fifteen days or so, Administrations start new accounts receivable and deal with old ones, not yet received. Unpaid bills may lead to blocking of service and the subsequent payment may lead to deblocking. Changes in customers' traffic pattern can indicate a source of fraud and a customer traffic blocking can be done. Claim about error in the bill asks for testing. Changes in tariff to be charged require equipment reconfiguration. Bills receiving process, beginning when the right is obtained, ends normally by the bill receiving. Exceptions imply several functionalities to take care of them.

### **6.5 Quality of Service and Network Performance Management**

Quality of Service degradation can be produced by a lot of root causes: failures, undersized resources, design error, etc. When no effective means of detection for some of these root causes can be implemented by any specific test or performance monitoring, the only way to discover them is by end-to-end QOS monitoring or through customer's claim. Sometimes, important QOS degradation takes several years to be solved and involves a number of experts. The most common QOS degradations are steady Hard-to-Reach (HTR) directions and poor transmission quality. Recommendations E.420 through E.428 and E.800 through E.880 cover this field of management. The QOS Management process starts with the detection of degradation and should finish with the corresponding root cause elimination, passing through intermediate stages of investigations, analysis, interviews, testing, etc.

Both network operators and equipment manufacturers have identified that increasing software and hardware complexity cause different and new system dependability problems. Design reliability models have recently been developed and it has been possible to improve Design Reliability Management. The process is similar to that described by Recommendation M.20 and is intended to remove the root cause of design reliability degradation. The symptoms appear in hardware design or in software design, but the root causes might have been existing in specification, system design, software design or hardware design phases.

A call that is lost at the terminating point is certainly the worst root cause of productivity degradation in a Telecommunication Network because the call crossed the entire network to be lost at the other end, mainly when we consider a Packet Switched Network. A number of root causes has been identified: wrong routing, wrong called-customer status, line defect, called customer doesn't answer or is busy. These last two proved to be the strongest offender of this class of root causes of productivity degradation. Whenever an abnormal loss of this kind is detected, a new process to eliminate the corresponding root cause is started.

Administrations have large experience with the consequences of bad behaviour of calling customers such as: automatic routing to a disconnected terminal, wrong dialling, interruption of dialling, etc. It was also discovered that some of the problems can be produced by customers device, or line, or line stage defects. Whenever an abnormal loss is found in this area, a new process of Loss on Calling Part Management is started. Some Administrations have a set of proactive actions to avoid this kind of abnormal loss.

## **6.6 Traffic Measurements and Analysis Administration**

Sometimes, real steady traffic is bigger or smaller than the planned. This may cause a strong steady overload and sometimes a strong underload. Both situations imply productivity degradation. They need to be corrected. It is also possible to forecast the future situation and implement proactive actions in order to avoid expected problems. When a current or future traffic problem is detected, a Traffic Administration process is started in order to eliminate the actual root cause of congestion or to avoid it in the future. Recommendations E.500 through E.721 and some of their Supplements are the ITU-T Recommendations in this field.

## **6.7 Traffic Management**

A number of events may arise which can have serious effects on the telecommunications services. Among these events are:

- failures of transmission systems and switching nodes;
- planned outages of telecommunications resources;
- abnormal increases in traffic demand. The events which give rise to such traffic demand may be foreseen (e.g. national or religious holidays, sporting events) or unforeseen (e.g. natural disasters, political crises, the death of a very important person);
- focused overload, and in particular, "mass-calling" (this text was derived from Recommendation E.410).

Any of such events can start Traffic Management process to eliminate the sudden overload root cause. The end of it could be an expansive action or a protective action as stated by Recommendation E.411.

Traffic Management is the object of the Recommendations E.410 through E.414.

## **6.8 Routing and Digit Analysis Administration**

The purpose of management of routing information in an exchange is to allow either a traffic or a routing manager to change the static routing information dynamically.

In specifying the management object classes for routing, certain requirements must be met:

- It must be possible to verify routing information in an exchange, with a minimal distortion in the normal operation of an exchange.
- It must be possible to switch between routing tables according to a pre-defined timing schedule, e.g. by introducing scheduling for routing tables.

- Functionality must be defined in such a way that routing tables may be changed easily.
- Redundant information must be avoided by making use of objects which exist during run time.
- It must be possible to expand the model with future requirements and therefore the specification of object classes for routing purposes.

## **6.9 Maintenance Management**

Every physical resource of telecommunications network has a specific MTBF (Mean Time Between Failures) parameter. New failures are always happening at some points of the networks. When detected, each failure, opening a specific trouble ticket, starts a new maintenance process as described in Recommendation M.20 (clause 5), to achieve the fault elimination. M-Series Recommendations have a wide approach to maintenance, covering analogue, digital and mixed networks.

By monitoring real field MTBF maximum likelihood estimate, two kinds of hardware reliability problems were found: MTBF estimate worse than that predicted by using MIL-STD failure rates, and a problem with the MTBF only for some specific field installations. By monitoring availability of switching systems, more than two hours of unavailability out of forty years were found. Whenever such problems are detected by Hardware Reliability Management, a new process is started in order to remove the specific root cause.

## **6.10 Security Administration**

(For further study.)

## **6.11 Logistics Management**

Materials management for stores, exchanges, transmission equipment and other parts of a telecommunications network enables the network operator to do the required installation work and maintenance. It allows calculation of the cost of a service offered to the customers and an improvement in the planning of a telecommunication network.

## 7 Management Services × Telecommunications Managed Areas Matrix

Telecommunications Managed Areas \ Management Services		TMN Users												
		Switching Telephone Network	Mobile Communications Network	Switched Data Network	Intelligent Network	CCSS No. 7	N-ISDN	B-ISDN	Dedicated and Reconfigurable Circuits Net.	TMN	IMT-2000 (FPLMTS)	Access and Terminal eq. Net.	Transport Network	Infrastructure
		1	2	3	4	5	6	7	8	9	10	11	12	13
Customer Administration		✓	✓	✓	✓		✓	✓	✓	✓	✓	✓		
Network Provisioning Management		✓	✓	✓	✓	✓	✓	✓	✓	✓	✓	✓	✓	✓
Work Force Management		✓	✓	✓	✓	✓	✓	✓	✓	✓	✓	✓	✓	✓
Tariff, Charging and Accounting Administration		✓	✓	✓	✓		✓	✓	✓		✓			
Quality of Service and Network Performance Administration		✓	✓	✓	✓	✓	✓	✓	✓	✓	✓	✓	✓	
Traffic Measures and Analysis Administration		✓	✓	✓	✓	✓	✓	✓		✓	✓		✓	
Traffic Management		✓	✓	✓	✓	✓	✓	✓		✓	✓		✓	
Routing and Digit Analysis Administration		✓	✓	✓	✓	✓	✓	✓	✓	✓	✓			
Maintenance Management		✓	✓	✓	✓	✓	✓	✓	✓	✓	✓	✓	✓	✓
Security Administration		✓	✓	✓	✓	✓	✓	✓	✓	✓	✓	✓	✓	✓
Logistics Management		✓	✓	✓	✓	✓	✓	✓	✓	✓	✓	✓	✓	✓

T0407120-96

**Figure 3/M.3200**

The ✓ sign in each crosspoint only means that the Telecommunications Managed Area in the column needs the Management Service indicated in the row. The set of signs in a column defines which Management Services could be used to accomplish the management of the correspondent Telecommunications Managed Area.

### 7.1 Relationship between this Recommendation and Recommendation M.3020

Recommendation M.3020 describes the TMN interface specification methodology and provides guidelines for the definition of TMN Management Services. This Recommendation identifies a number of TMN Management Services and introduces the concept of Telecommunications Managed Areas. Clause 5 of the present Recommendation identifies the areas of management, by giving a brief description of each of them. Clause 6 provides a generic list of TMN Management Services and

gives a short description of each. It shows the generic TMN management goals for each Management Service and presents benefits that TMN users obtain from these goals. The matrix of clause 7 provided the indications of Management Services, needed for each Telecommunications Managed Area.

## 7.2 M.3200-Series

The series of the TMN Management Services Recommendations is numbered according to the following template:

- M.32XX.y = (TMN Management Services for XX Managed Area.y sequential number that identifies one or more crosspoint of the matrix for the XX Telecommunications Managed Area). The XX number is determined, according to list of Telecommunications Managed Areas of clause 5 of this Recommendation. The y number will be assigned in a chronological basis by the Study Group 4.

### *Example*

M.3201.1:

M.32 TMN Management Service;

01 Switched Telephone Network (refer to the matrix);

- .1 the chronological number for the Recommendation covering one or several management services under the column for Switched Telephone Network (refer to the matrix),

i.e. TMN Management Services for Switched Telephone Network: Traffic Management, Traffic Measurements and Analysis Administration, Quality of Service and Network Performance Administration.

## 8 Relationships between TMN Management Services and existing Recommendations

TMN Management Services will replace human responsibilities of a pre-TMN environment, or create new capabilities of communications between organizations. Therefore, TMN Management Services and TMN Management Functions will have an impact on existing Recommendations. The development of new Recommendations for human operators in a TMN environment will sometimes be necessary in order to use TMN in an appropriate manner.

Study Groups/Working Parties within ITU-T which use a TMN Recommendation as a tool to realize their management applications, should take into account the impact of existing Recommendations on the introduction of TMN and initiate appropriate feedback if needed. This impact should be reflected when describing TMN Management Services.

## APPENDIX I

### Example of GDMS application

This appendix provides a reduced GDMS application to a matrix crosspoint to give users an example of M.3020 Task 1 and Task 2, producing TIB-A and TIB-B of the Maintenance Management of Switched Telephone Network. We will consider a very small number of resources to maintain this Recommendation as an overview document.

## I.1 Management Service Description

Every physical resource of the Switched Telephone Network has a specific MTBF (Mean Time Between Failures) parameter. New failures are always happening at some points of the network. When detected, each failure, opening a specific trouble ticket, starts a new maintenance process as described in 5/M.20, which continues until the Maintenance Entity (ME) recovery.

By monitoring real field MTBF maximum likelihood estimate, it is possible to find two main classes of hardware reliability problems: MTBF estimate worse than that predicted by using MIL-STD failure rates, or problems with the MTBF for some specific field installations only. By monitoring the switching systems availability, it is possible to find more than two hours of unavailability out of 40 years. Whenever such problems are detected, a new process is started in order to remove the specific root cause.

## I.2 Management goals

We know well that faulty ME recovery causes gain of QOS. The benefit can range from a very small quality improvement up to the recovery of a switch or sub-network after an outage. The elimination of abnormal MTBF reduces failure rates and gives customers better QOS, besides reducing maintenance and spares inventory costs.

## I.3 Management Context Description

### I.3.1 Dynamic view of Management Context

When a Role is performed, TMN users and TMN are involved alternately through interactions between them. A sequence of Roles is the realization of a specific TMN Management Service. A Role is performed through human actions and Management Application Functions (MAF). MAFs are the automated part of a Role. When considering a TMN Management Service as a key business process, a Role is a subprocess (business viewpoint). When we consider a TMN Management Service as a complete life cycle, a Role is a phase (R,D&E viewpoint, e.g. the phases described in Recommendation M.20 in the case of Maintenance Management). When we consider a TMN Management Service as a birth and death process, again a Role is a subprocess (mathematical modelling viewpoint). Under the three viewpoints, a Role remains what is defined in Recommendation M.3020, i.e. "the activities which are expected of the staff/system to perform telecommunications management". During the performance of each Role, **operations** and **notifications** will take place and several messages will flow through TMN interfaces, using TMN Management Functions. Operations are generated by TMN users to produce actions over managed objects (e.g. the command to block a killer trunk). Notifications are generated by the managed objects to inform something to TMN users (e.g. the alarm of frame alignment lost, produced by Recommendation G.732 when the limit of error bit rate is reached). Each message can cross several TMN interfaces to reach their end points (e.g. Qx, Q3, X and F for a notification and F, Q3 and Qx for an operation). Although operations reach managed objects and notifications are generated by managed objects, the correspondent sink/source point are the physical or logical or human resources of Telecommunications.

### I.3.2 Resources

We have chosen for this exercise a hypothetical switch that is implemented as proprietary local area network, i.e. network of computers, having a switching matrix and being a digital exchange. Although the MEs are physical, we will also consider logical resources, represented by the software that is loaded in the computers and occupies a certain memory area. Each software module has services implemented in a client/server approach. The degradation of a service can possibly indicate a physical fault in the computer where it is loaded.

### **I.3.2.1 Physical Resources**

This example considers a very small part of a switch, i.e. a digital circuit group connecting two digital exchanges. The circuit group is the last choice in the routing plan. The exchanges involved belong to different Administrations, having both their own TMN. The circuit group contain four 2 Mbit/s links of PDH technology. Under this environment, the resources to be managed are:

- the circuit group;
- each 2 Mbit/s link with the following ME: Power Source, Microcomputer, Digital Circuit Terminal and Switching Matrix Access;
- each 64 kbit/s digital circuit, having read/write memories as ME.

### **I.3.2.2 Logical Resources**

There is a software implementing the switching and signalling functions for the digital circuits within each 2 Mbit/s link. The circuit group is R2-MFC signalling and line signalling is e/m pulse.

### **I.3.3 Roles**

#### **I.3.3.1 Performance measuring and alarm monitoring**

It is the continuous or periodic (routine) checking of functions.

The performance of each Circuit Group is supervised through the following robust estimates: Peg Count, Mean Holding Time, Mean Conversation Time and Call Completion Rate. There are two stochastic objectives for each of this variables, established by the Operating Company. Whenever one of them crosses a severe or normal performance exception, a notification is issued. The confidence level of each notification is 99.9999%.

There are the following alarms concerning the 2 Mbit/s links: Loss of Power Supply, Microcomputer out of service, Recommendation G.732 alarms and Switching Matrix Access out of service. The performance is supervised by the same robust estimates of Circuit Group, considering only the circuits of the link.

There are the following alarms to monitor each circuit: sign bit stuck at abnormal signal-to-noise ratio and successive short holding time.

The performance is supervised through the maximum likelihood estimates of the following variables of each circuit: Peg Count, Mean Holding Time, Mean Conversation Time and Call Completion Rate. An exception is determined using a 99.9999% two-sided confidence interval and using a null hypothesis based on the robust estimate of the circuit group.

#### **I.3.3.2 Failure detection**

Whenever an alarm condition is reached or a performance exception is established, a malfunction or possible malfunction is detected. A prompt or deferred maintenance alarm or a maintenance event is generated by the Maintenance Entity (ME). Any alarm or performance exception message must be routed to the OS of the following Management Services: Maintenance Management, Work Force Management, Traffic Management and Traffic Measurement and Analysis Administration. This must be done by addressing the messages to the OS of both Operating Companies involved, i.e. the OSs of the two TMNs.

#### **I.3.3.3 System protection**

By blocking the ME or by rerouting, the effect of failure is minimized, i.e. by excluding the faulty ME from operation or bypassing the faulty physical resource.



### **I.3.3.4 Analysis**

Interactions involving Staff/TMN are performed, through alarm correlations and other techniques, to determine the smallest region containing the root cause, obtaining in this way the most effective dispatch.

### **I.3.3.5 Fault localization**

When fault information is insufficient, the determination of faulty ME is performed with the help of internal test systems or external test systems, automated, automated or not, and after that the exact root cause is localized.

### **I.3.3.6 Fault correction**

As the root cause is localized, the correction of the faulty ME can be done through repair or replacement of the faulty part by a spare.

### **I.3.3.7 Verification**

The correction is not always well done. The check of ME after fault correction is performed, using a fault localization similar procedure, to ensure that malfunction of the ME was eliminated.

### **I.3.3.8 Restoration**

Through unblocking or the end of changeover, the restoration of ME normal function is attempted. After succeeding the attempt, the ME returns to service or to standby mode.

## **I.3.4 TMN Management Functions Sets and Set Groups**

As the Roles presented in the previous subclauses are being developed, flow of messages through the TMN interfaces will be required. Having in mind the resources listed above, the next items present the needed TMN Management Functions Sets (refer to Recommendation M.3400).

### **I.3.4.1 Performance Management**

Under the Performance Management Control group we will need the following TMN Management Function Sets: Generic function set; Detection, storage, counting and reporting function set; Traffic status function set; Traffic performance function set and Performance monitoring policy function set.

Under the Performance Analysis group we will need the Exception threshold policy function set.

### **I.3.4.2 Fault Management**

We will need the following TMN Management Function Set Groups: Alarm Surveillance, Fault Localization, Fault Correction and Trouble Administration.

### **I.3.4.3 Configuration Management**

We will need the following TMN Management Function Sets: Loading NE software function set, NE configuration function set, Circuit inventory function set and Circuit inventory query function set.

## **I.4 Architecture**

The functional and physical architectures are presented in Figures 4 and 5. They are designed addressing some of the needed TMN Management Functions as follows:

- successive short holding time circuit (killer trunk) **alarm report** – N1;  
NOTE 1 – At the same time the NE blocks the faulty circuit.
- **request** circuit and circuit group **PM data** – O1;

- circuit and circuit group **PM data report** – N2;
- **connect test access** – O2;
- **Measure E1 Signals** – O3;
- **Terminate Test Measurements** – O4;
- **Request Test Results** – O5;
- **Test Results Reporting** – N3;
- Unblock the circuit – O6.

NOTE 2 – The bold texts are TMN Management Functions captured from Recommendation M.3400. NX means X-order notification and OX means X-order operation.

This set of TMN Management Functions is divided into the following subgroups of messages that flow at the related reference points/interfaces:

GROUP1 = (N1, O1, N2, O2, O3, O4, O5, N3, O6);

GROUP2 = (N1, O1, N2, O2, ..., O6);

GROUP3 = (N1, O1, N2).

NOTE 3 – In this example, the functions for the f/x reference points and F/X interfaces are subsets of the functions for the q3/Q3. In other cases, the functions for the f/F and x/X may be a superset of the q3/Q3 functions, or may be different functions. Also note that functions may be implemented differently on the F interface than on the Q. The functions, information models and protocols are under study.

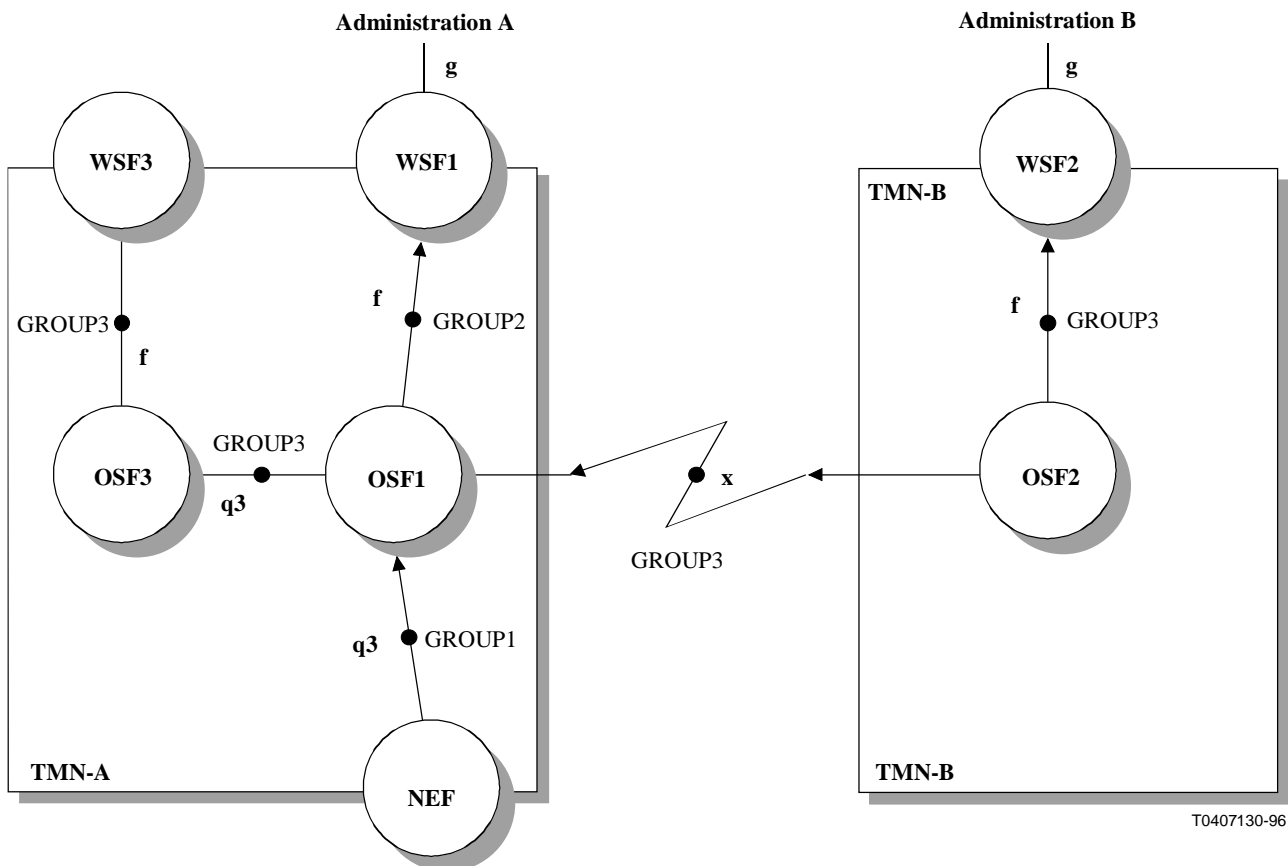

T0407130-96

Figure 4/M.3200 – Functional architecture

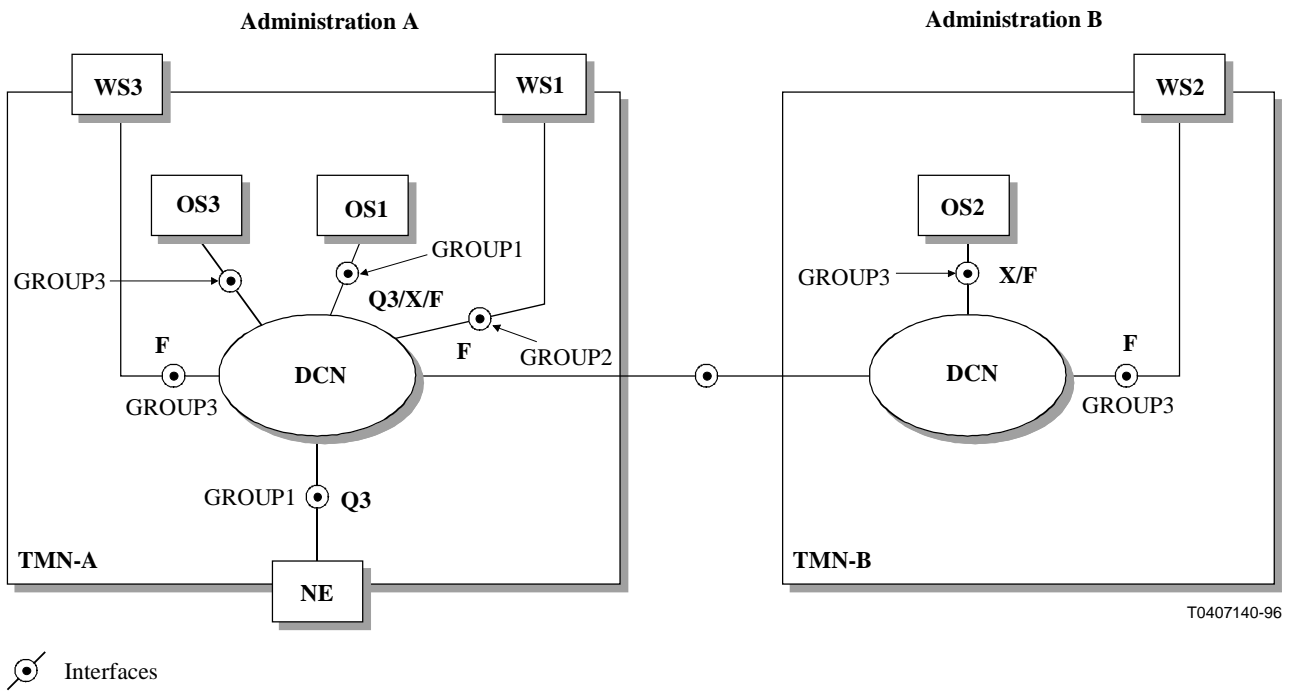

**Figure 5/M.3200 – Physical architecture**

## I.5 Scenarios

Figure 6 provides an example of management interactions using the information defined above, the CMIS services and CMIP protocol.

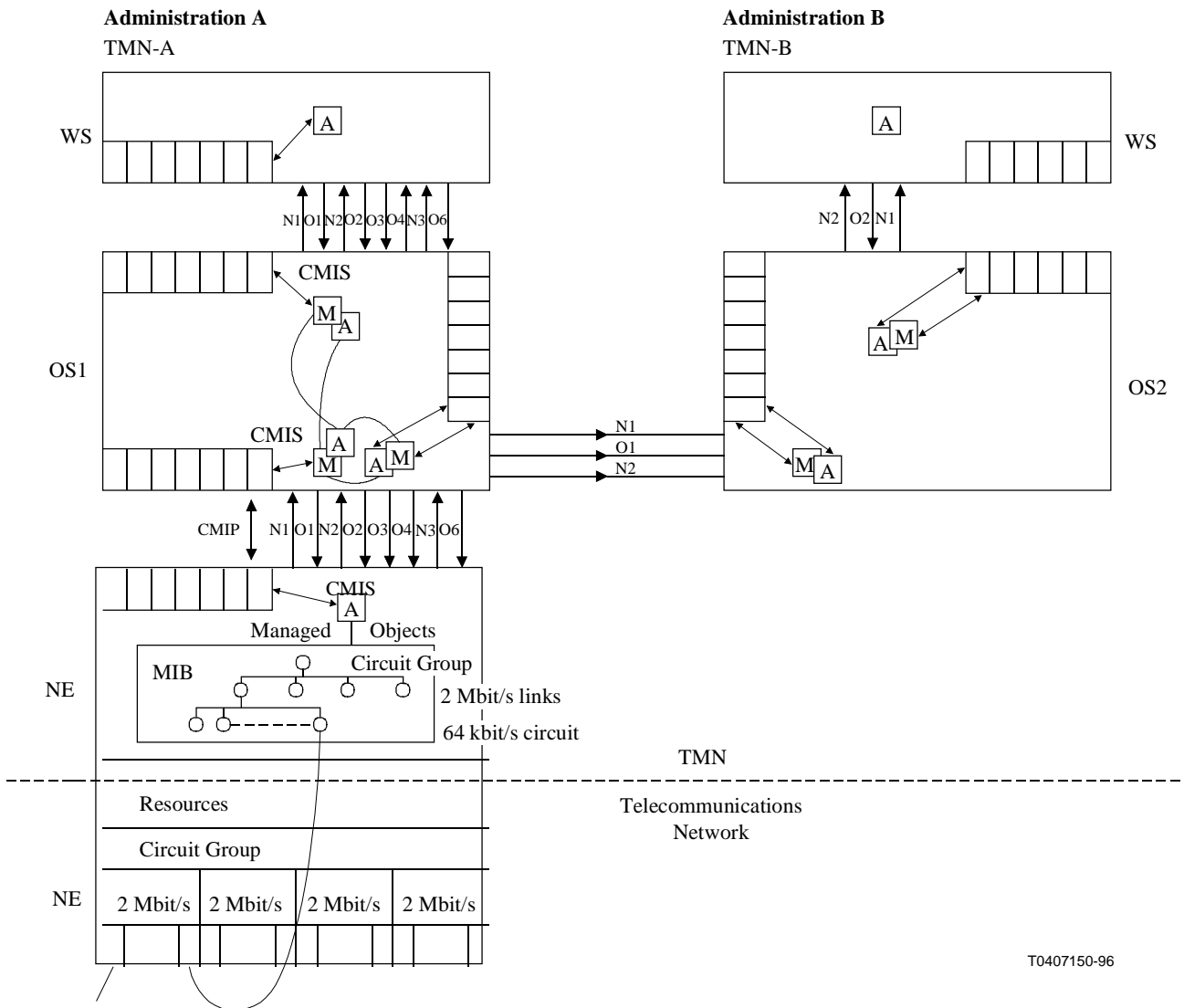

T0407150-96

64 kbit/s circuit  
 OS1 Maintenance and Work Force Management  
 OS2 Traffic measurements and analysis administration/traffic management

**Figure 6/M.3200 – Management interactions**

## ITU-T RECOMMENDATIONS SERIES

Series A	Organization of the work of the ITU-T
Series B	Means of expression: definitions, symbols, classification
Series C	General telecommunication statistics
Series D	General tariff principles
Series E	Overall network operation, telephone service, service operation and human factors
Series F	Non-telephone telecommunication services
Series G	Transmission systems and media, digital systems and networks
Series H	Audiovisual and multimedia systems
Series I	Integrated services digital network
Series J	Transmission of television, sound programme and other multimedia signals
Series K	Protection against interference
Series L	Construction, installation and protection of cables and other elements of outside plant
<b>Series M</b>	<b>TMN and network maintenance: international transmission systems, telephone circuits, telegraphy, facsimile and leased circuits</b>
Series N	Maintenance: international sound programme and television transmission circuits
Series O	Specifications of measuring equipment
Series P	Telephone transmission quality, telephone installations, local line networks
Series Q	Switching and signalling
Series R	Telegraph transmission
Series S	Telegraph services terminal equipment
Series T	Terminals for telematic services
Series U	Telegraph switching
Series V	Data communication over the telephone network
Series X	Data networks and open system communication
Series Z	Programming languages