



INTERNATIONAL TELECOMMUNICATION UNION

ITU-T

M.475

TELECOMMUNICATION
STANDARDIZATION SECTOR
OF ITU

**MAINTENANCE :
INTERNATIONAL TRANSMISSION SYSTEMS
(ANALOGUE)**

**SETTING UP AND LINING UP MIXED
ANALOGUE/DIGITAL CHANNELS
FOR INTERNATIONAL TELECOMMUNICATION
SERVICES**

ITU-T Recommendation M.475

(Extract from the *Blue Book*)

NOTES

1 ITU-T Recommendation M.475 was published in Fascicle IV.1 of the *Blue Book*. This file is an extract from the *Blue Book*. While the presentation and layout of the text might be slightly different from the *Blue Book* version, the contents of the file are identical to the *Blue Book* version and copyright conditions remain unchanged (see below).

2 In this Recommendation, the expression “Administration” is used for conciseness to indicate both a telecommunication administration and a recognized operating agency.

© ITU 1988, 1993

All rights reserved. No part of this publication may be reproduced or utilized in any form or by any means, electronic or mechanical, including photocopying and microfilm, without permission in writing from the ITU.

Recommendation M.475

SETTING UP AND LINING UP MIXED ANALOGUE/DIGITAL CHANNELS FOR INTERNATIONAL TELECOMMUNICATION SERVICES

1 Check of FDM multiplex or transmultiplexer equipment

The FDM multiplex or transmultiplexer equipment, before it is connected to a group or supergroup link, must be checked to ensure that it meets CCITT Recommendations and the other relevant specifications. The check should include a general visual inspection and vibration tests, if applicable. This is of particular importance if the equipment has remained unused since acceptance tests were carried out after installation.

2 Setting up and lining up mixed analogue/digital channels

The definition of a mixed analogue/digital channel is given in Recommendation M.300. When these channels are used for international telephone circuits, the required circuit transmission loss will in many cases be established through the use of variable loss pads in the transmultiplexer. For these mixed analogue/digital channel applications, Administrations may, through bilateral agreement, defer the separate channel line-up procedures contained in this Recommendation, and perform, instead, the appropriate circuit section and circuit line-up procedures of Recommendation M.580.

As a prerequisite to setting up and lining up channels using the procedures in this Recommendation, the involved group and supergroup links shall have been set up and lined up in accordance with Recommendation M.460.

2.1 *Measurement and adjustment of levels*

Depending upon the type of test equipment used, and the access features of the transmultiplexer, the following procedures may require taking an entire transmultiplexer out of service while each channel is being lined up. Careful consideration should be given to procedures for removing transmultiplexers from service, and for restoring them to service, especially where the group links which terminate on the transmultiplexer are not co-terminous, or where international leased circuits are provided on transmultiplexers.

2.1.1 *Transmultiplexers at each end of the group or supergroup link*

Note – These configurations are shown in a) and b) of Figure 1/M.475.

After the group or supergroup links have been set up, and the transmultiplexing equipments at the ends of the group or supergroup links have been checked and connected, the channels are adjusted as follows.

At the transmitting end, a bit sequence corresponding to 1020 Hz¹⁾ test tone at a level of –10 dBm₀ is applied to the 64 kbit/s time slot appearance of each channel in turn, at the digital path access point associated with the input to the transmultiplexer, using appropriate digital test equipment. At the receiving end, the 64 kbit/s time slot appearance of each channel is monitored in turn at the digital path access point associated with the output of the transmultiplexer, using appropriate digital test equipment, and each channel is adjusted as near as possible to its nominal level.

2.1.2 *24-channel transmultiplexer at one end of the group links, with channel translating equipment at the other end*

Note – This configuration is shown in c) of Figure 1/M.475.

After the group links have been set up, and the transmultiplexing and channel translating equipments at the ends of the group links have been checked and connected, the channels are adjusted as follows.

Transmitting from the channel translating equipment towards the transmultiplexer, an 1020 Hz¹⁾ test signal is sent over each channel in turn at a level of –10 dBm₀. The channel translating equipment is adjusted so that the sideband level on each channel is as near to the nominal level as possible. At the receiving end, the 64 kbit/s time slot corresponding to each channel is monitored in turn at the digital path access point associated with the output of the transmultiplexer, and each channel is adjusted to obtain the bit sequence corresponding to the nominal level of the received test signal.

¹⁾ For further information about the choice of the test signal frequency, refer to Recommendation O.6 [1].

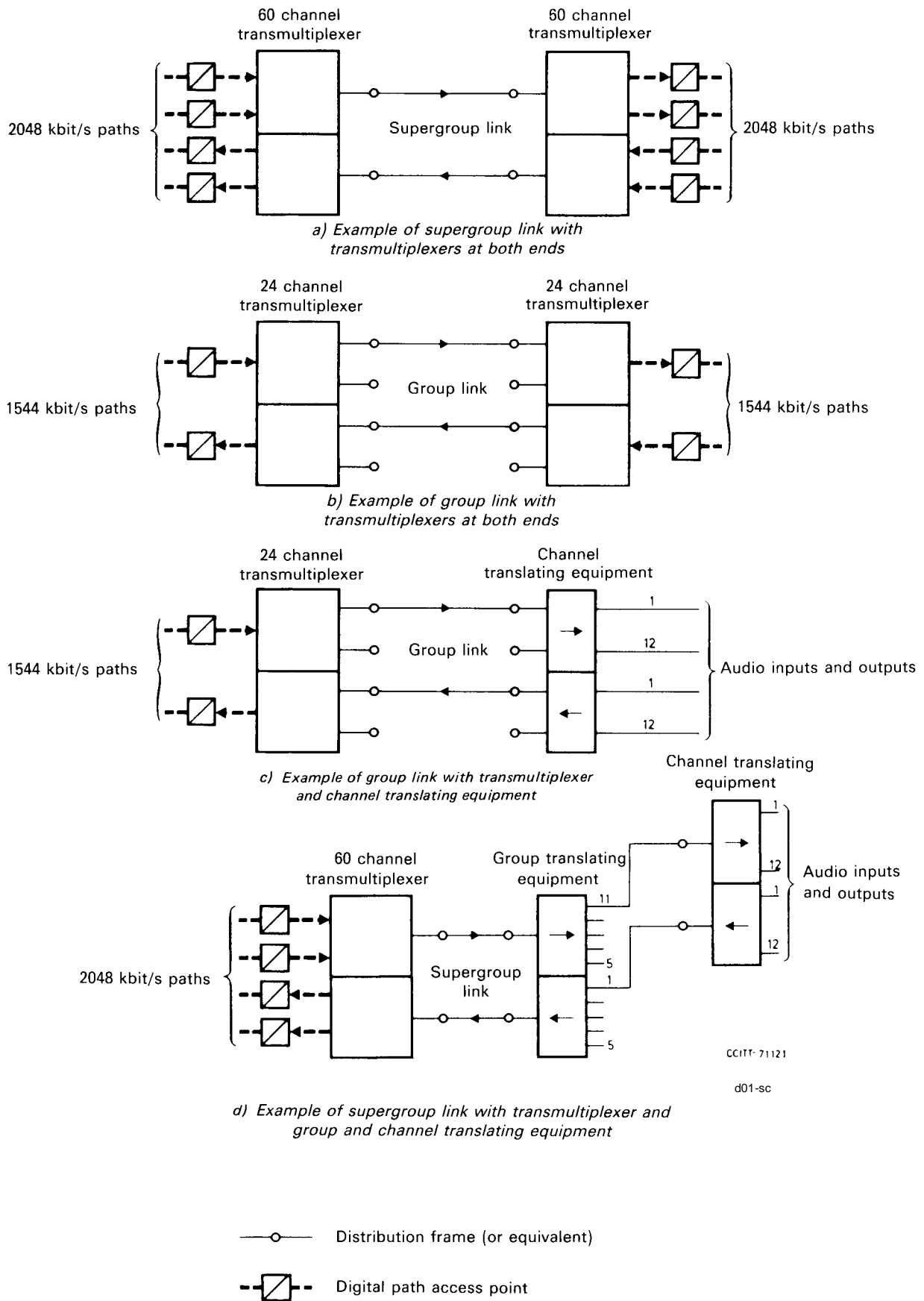

FIGURE 1/M.475

Transmitting from the transmultiplexer towards the channel translating equipments, a bit sequence corresponding to 1020 Hz²⁾ test tone at a level of –10 dBm0 is applied to the 64 kbit/s time slot of each channel in turn, at the digital path access point associated with the digital input to the transmultiplexer, using appropriate digital test equipment. At the receiving end, the channel translating equipment should then be adjusted to bring the received level on each channel as near as possible to its nominal value.

2.1.3 *60-channel transmultiplexer at one end of a supergroup link, with group and channel translating equipments at the other end*

Note – This configuration is shown in d) of Figure 1/M.475.

After the supergroup link and group links have been set up, and the transmultiplexing, group translating, and channel translating equipments at the ends of the supergroup link and group links have been checked and connected, the channels are adjusted by the following procedures in § 2.1.2 above.

3 Check level of line signalling

In the case of groups which are intended to be used for telephone circuits employing Signalling System R2, the checks of signalling level stipulated in the Specifications of Signalling System R2 should be made [2].

For other signalling systems, the check of signalling level should be carried out at the circuit line-up stage (see the Recommendation M.580).

References

- [1] CCITT Recommendation *1020 Hz reference test frequency*, Vol. IV, Rec. O.6
- [2] CCITT Recommendations *Specifications of Signalling System R2*, Vol. VI, Recs. Q.400 to Q.490.

²⁾ For further information about the choice of the test signal frequency, refer to Recommendation O.6 [1].