



INTERNATIONAL TELECOMMUNICATION UNION

ITU-T

TELECOMMUNICATION
STANDARDIZATION SECTOR
OF ITU

K.35

(05/96)

PROTECTION AGAINST INTERFERENCE

**BONDING CONFIGURATIONS AND EARTHING
AT REMOTE ELECTRONIC SITES**

ITU-T Recommendation K.35

(Previously "CCITT Recommendation")

FOREWORD

The ITU-T (Telecommunication Standardization Sector) is a permanent organ of the International Telecommunication Union (ITU). The ITU-T is responsible for studying technical, operating and tariff questions and issuing Recommendations on them with a view to standardizing telecommunications on a worldwide basis.

The World Telecommunication Standardization Conference (WTSC), which meets every four years, establishes the topics for study by the ITU-T Study Groups which, in their turn, produce Recommendations on these topics.

The approval of Recommendations by the Members of the ITU-T is covered by the procedure laid down in WTSC Resolution No. 1 (Helsinki, March 1-12, 1993).

ITU-T Recommendation K.35 was prepared by ITU-T Study Group 5 (1993-1996) and was approved under the WTSC Resolution No. 1 procedure on the 8th of May 1996.

NOTES

1. In this Recommendation, the expression "Administration" is used for conciseness to indicate both a telecommunication administration and a recognized operating agency.
2. The status of annexes and appendices attached to the Series K Recommendations should be interpreted as follows:
 - an *annex* to a Recommendation forms an integral part of the Recommendation;
 - an *appendix* to a Recommendation does not form part of the Recommendation and only provides some complementary explanation or information specific to that Recommendation.

CONTENTS

| | <i>Page</i> |
|---------------------------------------------------|-------------|
| 1 Introduction | 1 |
| 2 Scope | 1 |
| 3 Definitions | 2 |
| 4 Earthing network for EEEs | 2 |
| 4.1 Earthing ring for AG/EEEs and BG/EEEs | 2 |
| 4.2 Earthing ring for EEC | 3 |
| 4.3 Concrete-encased earth electrode | 3 |
| 5 a.c. power distribution | 3 |
| 5.1 a.c. power line surge protective device | 3 |
| 6 d.c. power distribution | 5 |
| 7 Bonding configuration | 5 |
| 7.1 Main Earthing Terminal | 5 |
| 7.2 Interior bonding-bus | 5 |
| 7.3 Outside-plant cable entrance | 6 |
| 7.4 Equipment framework | 7 |
| 7.5 Surge protectors on communication pairs | 7 |
| 7.6 Metallic walls | 7 |
| References | 7 |
| Appendix I | 8 |

BONDING CONFIGURATIONS AND EARTHING AT REMOTE ELECTRONIC SITES

(Geneva, 1996)

1 Introduction

Electronic Equipment Enclosures remotely located from telecommunication buildings increasingly are being used to contain a variety of telecommunication equipment. Differences such as size, shape and local environmental stresses give rise to the need for electromagnetic compatibility measures that differ from those at telecommunication buildings [1] or at subscribers' premises [2].

The nomenclature and measures of this Recommendation are intended to promote harmony of installation and equipment configurations while providing for personnel safety and electromagnetic compatibility.

Although the bonding configurations and earthing measures of this Recommendation contribute to the reduction of electrical surge energy that reaches installed equipment, surge protectors, as described in Recommendation K.11 [3], may be needed on the conductors of wire-line cables. Furthermore, the equipment must be capable of resisting the residual surges that reach it; equipment resistibility is described in Recommendation K.20 [4].

2 Scope

This Recommendation covers bonding configurations and earthing for equipment located at remote electronic sites such as switching or transmission huts, cabinets or controlled environmental vaults with only one level, a need for a.c. mains power service, and a floor space of about 100 m² without an antenna tower on the roof of the building as well as nearby; but are more substantial than small electronic housings, such as carrier repeaters or distribution terminals. Experience in the operation of Electronic Equipment Enclosures shows that the use of a bonding configuration and earthing that are coordinated with equipment capability and with electrical protection devices has the following attributes:

- promotes personnel safety and reduces fire hazards;
- enables signalling with earth return (functional earthing);
- minimizes service interruptions and equipment damage caused by lightning, exposures to power lines and faults in internal d.c. power supplies;
- minimizes radiated and conducted emissions and susceptibility;
- improves system tolerance to discharge of electrostatic energy.

Within this framework, this Recommendation:

- a) is a guide to bonding configurations and earthing of telecommunication equipment in Electronic Equipment Enclosures;
- b) is intended to comply with safety requirements imposed by IEC [5] or national standardizing bodies on a.c. power installations;
- c) is intended for installation of new Electronic Equipment Enclosures;
- d) treats coordination with electrical protection devices, but does not provide details of protective measures specific to Electronic Equipment Enclosures;
- e) utilizes the shielding contribution of effective elements of the structure and its contents;
- f) addresses the bonding of cable shields;
- g) is intended to facilitate electromagnetic compatibility of telecommunications equipment;
- h) does not include protection against LEMP (Lightening Electromagnetic Pulse).

3 Definitions

In this Recommendation, definitions with respect to bonding configurations and earthing already introduced by the IEC [6] and Recommendation K.27 [1] are used to maintain conformity. Additional definitions needed for remote electronic sites are in this clause.

3.1 electronic equipment enclosure (EEE): A structure that provides physical and environmental protection for electronic communication equipment, and that:

- has only one level;
- has a floor space of no more than about 100 m²;
- has a need for a.c. mains power service.

3.2 above-ground electronic equipment enclosure (AG/EEE): An EEE that is wholly or partially above ground level. Installed equipment is fully accessible from the interior area. The AG/EEE subcategory includes transportable structures as well as structures partially or fully constructed or assembled on-site.

3.3 below-ground electronic equipment enclosure (BG/EEE): An EEE that is completely below ground level except possibly for an entryway, a.c. power service, and environmental control equipment. Installed equipment is fully accessible from the interior area.

3.4 electronic equipment cabinet (EEC): An EEE for which all installed equipment can be fully accessed from the outside without having to enter an interior area.

3.5 bonding-bus: A conductor, or group of conductors, that serves as a common connection between the Main Earthing Terminal [6] and metallic assemblies in the EEE. The bonding-bus may also be connected to other busbars or terminals connected to the Earthing Network [6] or structural steel.

3.6 ring bonding-bus: A bonding-bus whose conductors form a closed, connected ring.

An example of bonding configurations and earthing of EEEs by use of ring bonding-bus is shown in Appendix I.

4 Earthing network for EEEs

4.1 Earthing ring for AG/EEEs and BG/EEEs

An AG/EEE or BG/EEE should be provided with a buried exterior earthing ring that satisfies at least the following conditions:

- the ring should be uninsulated and buried at approximately 0.75 m;
- the ring should encircle the EEE with a spacing, where practical, of about 0.65 m or more from the exterior walls;
- one earthing conductor should connect the ring to the Main Earthing Terminal [6].

NOTE – National safety rules may require additional rod electrodes and/or additional connections to the a.c. power service entrance.

An alternative to the foregoing attachments to the earthing ring is to connect the neutral busbar to a separate earthing network using a separate earthing conductor; the earthing conductor from the Main Earthing Terminal to the earthing ring remains. The Main Earthing Terminal and the neutral busbar are connected within the EEE. This alternative arrangement permits occasional isolation of the earthing ring to monitor its condition without disconnecting the earthing connection on the neutral conductor.

4.2 Earthing ring for EEC

The earthing network provides some voltage equalization in the earth near an EEC. The EEC should be provided with a buried exterior earthing ring that satisfies at least the following conditions:

- the ring should be uninsulated, buried at a depth of 0.3 - 0.5 m;
- the ring should encircle the foundation pad of the EEC or be located below the perimeter of the pad;
- one uninsulated earthing conductor should connect the ring to the Main Earthing Terminal [6].

NOTE – National safety rules may require additional rod electrodes and/or additional connections to the a.c. power service entrance.

4.3 Concrete-encased earth electrode

An EEE often rests on a foundation earth electrode [7], or is itself constructed of concrete. In this case, the reinforcement or conductor may be used in place of the earthing ring of subclauses 4.1 and 4.2.

5 a.c. power distribution

It is recommended that the indoor mains installation within a telecommunication building be of type TN-S as specified by the IEC [5] in order to improve the EMC performance of the telecommunication installation. This requires that there shall be no PEN conductor within the building. Consequently, a three phase network within a telecommunication building is, physically, a five-wire installation (L1, L2, L3, N, PE).

Depending on the type of outdoor mains distribution network serving a telecommunication building, one of the following requirements shall apply:

- a) Service by a TN-S section of the outdoor mains distribution network:
 - 1) solely the protective conductor (PE) shall be connected to the main earthing terminal (see Figure 1, mode 1).
- b) Service by a TN-C section of the outdoor mains distribution network:
 - 1) the PEN conductor shall be connected to the main earthing terminal only;
 - 2) from the main earthing terminal to and within customer locations inside the building, the neutral conductor (N) shall be treated as a live conductor;
 - 3) a dedicated PE shall be provided (see Figure 1, mode 2).
- c) Service by a TT or IT section of the outdoor mains distribution network:
 - 1) the PE shall be derived via the main earthing terminal from the earthing network;
 - 2) the dimensioning of the PE shall follow the rules of the TN-S system.

If the outdoor mains distribution is of type IT or TT, a separation transformer dedicated to that building allows for the recommended TN-S installation. In this case the indoor mains installation must conform to mode 1, Figure 1.

5.1 a.c. power line surge protective device

The a.c. mains input to the EEE should be equipped with a surge protective device. A specification for a low-voltage surge protective device is in advanced stages of preparation by IEC Subcommittee 37A.

The surge protective device should be connected to the mains conductors on the load side of the circuit breaker.

The surge protective device should be located where the leads for connection to the mains conductors, including the earthed (neutral) conductor, are as short as possible. Lead lengths that are less than 0.5 m are recommended.

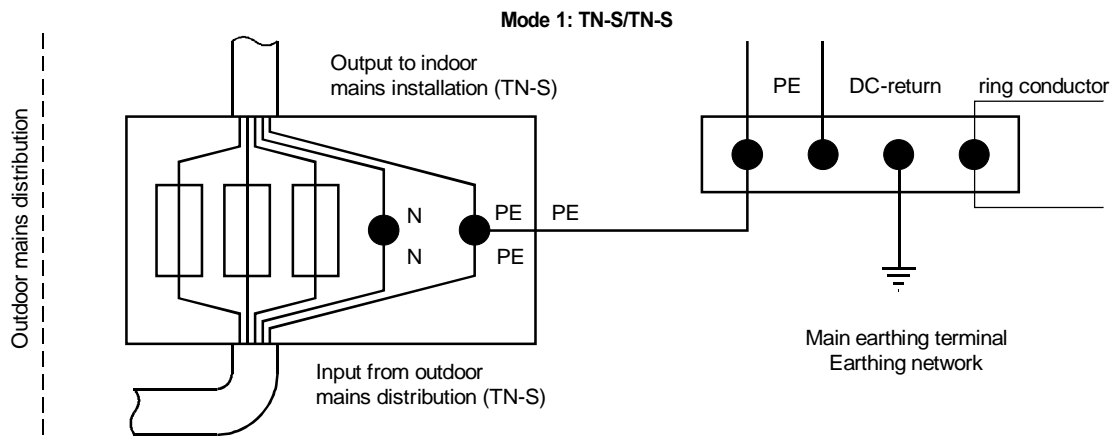

NOTE – Mode 1 is obligatory if a separation transformer is dedicated to the building and the TN-S system consequently originates at the transformer load side.

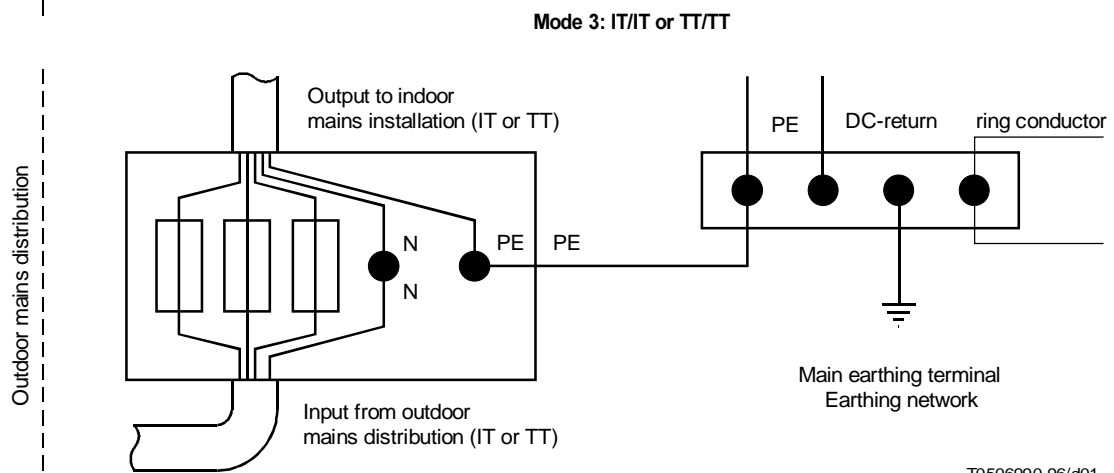
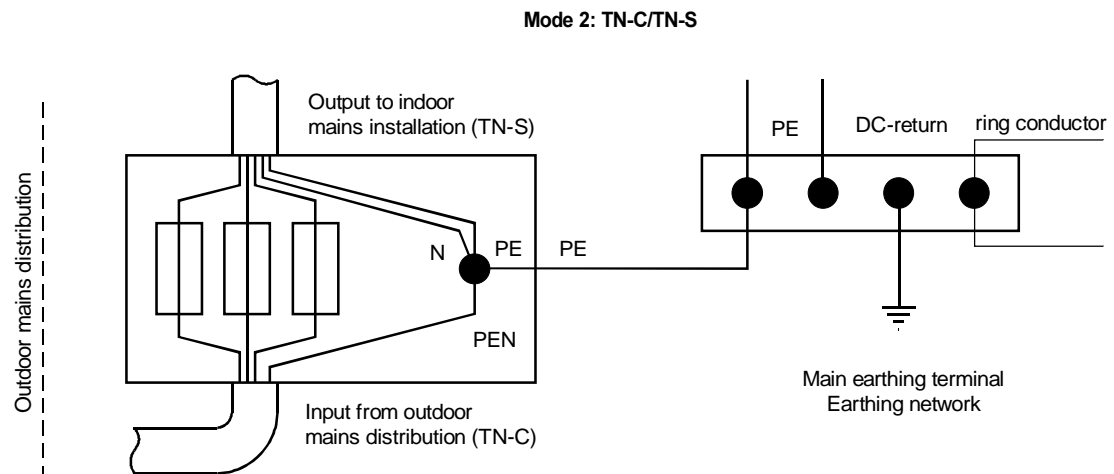

T0506990-96/d01

FIGURE 1/K.35

Arrangements for the transition from the outdoor mains distribution network to the indoor mains

6 d.c. power distribution

In many EEEs, d.c. power is generally distributed from a centralized d.c. power plant (bulk power plant), with the positive terminal connected to the common bonding network [1] of the structure. This polarity is chosen to minimize corrosion in the outside cable plant, but there may be exceptions for specific transmission systems.

The return conductor of the d.c. distribution system may be connected to the Common Bonding Network (CBN) in either of two manners. It may be connected at only one location as an isolated d.c. return system (dc-I). Or the d.c. return may connect to the CBN at several locations (in which case some d.c. current is conducted by the CBN), as a d.c. return common to a CBN (dc C-CBN). Because of the small size of an EEE, the common-mode voltages (and the conversion to transverse mode voltage) supported by either of these two distribution systems should be comparable.

NOTE – The Common Bonding Network of an EEE comprises the bonding-bus conductors, a.c. power conduit, PE conductors, structural steel, and cable and racks [1].

The bonding conductor that connects the return side of the d.c. power source to the interior bonding-bus should be capable of conducting the maximum fault current of the power system. Rapid operation of overcurrent protective devices is aided by connecting cable racks to the bonding-bus and providing electrical continuity between rack sections.

Because of the close proximity of equipment in an EEE, it is important that equipment not be sensitive to voltage surges on the d.c. power caused by short-circuits in other equipment.

7 Bonding configuration

The bonding configuration in the EEE makes use of a CBN that includes all available metallic structural components and metallic cable trays and supports, augmented by an interior ring bonding-bus. The interconnected CBN reduces the magnitude of external surge current that is conducted on the framework of the enclosed equipment.

This Recommendation covers the case where equipment is connected to the CBN in a Mesh-BN configuration [1]. This bonding configuration helps provide an equipotential environment for personnel in the close confines of the EEE. It also assures the presence of many parallel current paths to help de-energize a short-circuit in the d.c. supply and to mitigate the effects of surge currents. (Equipment can be connected to the CBN using other bonding configurations, but such cases are not covered in this Recommendation.)

NOTE – This Recommendation requires minimum earthing and bonding configurations for remote electronic sites. Additional bonding network [1] may be installed to improve the EMC performance.

7.1 Main Earthing Terminal

The principal location for the interconnection of earthing and bonding conductors of an EEE should be a busbar (or equivalent) that is within 2 m of the neutral terminal in the disconnecting apparatus of the power mains. This busbar serves as the Main Earthing Terminal.

Bonds should be placed between the Main Earthing Terminal and:

- the terminal used by the protective earth conductor in the entrance cabinet containing disconnecting apparatus for the power mains;
- the exterior earthing ring;
- the terminal, if present, connected to reinforcement bars or other concrete-encased conductors.

7.2 Interior bonding-bus

The Common Bonding Network of an EEE should include an interior bonding-bus composed of copper conductors. This bonding-bus provides potential equalization within the EEE and serves as a common connection between the Main Earthing Terminal and metallic assemblies, such as equipment enclosures and frames.

7.2.1 Ring bonding-bus for AG/EEE and BG/EEE

For AG/EEEs and BG/EEEs, the interior bonding-bus should form a closed ring. The conductors of the ring bonding-bus should be attached to the walls or along the exterior of cable racks near the walls. The ring bonding-bus should be at a height that is accessible for visual inspection and for connection of equipment assemblies.

The interior ring bonding-bus should be connected to the Main Earthing Terminal, and should also be connected to any terminals in the EEE that attach to structural steel.

A supplementary bonding-bus (Figure I.1) should be bridged across the ring for the bonding of equipment installed away from the walls. Both ends of the supplementary bonding-bus should be connected to the ring.

Metallic wall sheathing should be used as a ring bonding-bus only if the metallic wall panels are designed for this purpose, continuity can be assured and terminals are provided for attachment of bonding conductors.

7.2.2 Bonding-bus for EEC

It is not necessary for the bonding-bus in an EEC to form a closed ring. The bonding-bus conductors can alternatively be provided by low-impedance structural components. The structural components and their interconnections should be capable of conducting fault currents from the d.c. power supply, and should be protected against corrosion.

The bonding-bus should be connected to the Main Earthing Terminal of the EEC.

7.3 Outside-plant cable entrance

7.3.1 Location of entry ports

The separation of incoming services at their entry into the EEE and the entry of the mains power should be as small as possible. A separation of less than 4 m is recommended. The separation between the entry ports of the outside-plant cables and the Main Earthing Terminal should also be less than 4 m (measured along walls). To avoid interference caused by magnetic field due to currents on power cables, it is usual practice to separate telecommunications cable from parallel unshielded power cables at least 10 cm, unless other shielding measures are taken. For an EEC, it is recommended that the cable entry ports be adjacent to the disconnecting apparatus of the power mains.

7.3.2 Bonding of metallic components

Metallic screens or other metallic structural components of the outside-plant cables should be bonded to the interior bonding-bus or directly to the Main Earthing Terminal. The connection of the bonding conductor to the metallic components of the cables should be as close as practical to the cable entry port; the distance along the cable from the entry port to the bond connection should not exceed 2 m. If the outside-plant cables extend into the EEE beyond the bond connection, a second bond to the bonding-bus should be placed at the termination of the cables where they are spliced to internal cables.

NOTE – If it is not possible to locate the entry port of the outside-plant cables within 4 m (measured along walls) of the Main Earthing Terminal, an additional connection to the outside-plant cables is needed from at least one of the following:

- a conductor directly connected to the exterior earthing ring;
- a conductor directly connected to a foundation earth electrode or to the steel reinforcing members of the structure;
- second interior ring bonding-bus. One ring bonding-bus should be near the ceiling, and the other near the floor.

This additional connection to the outside-plant cables should be as close as practical to the entry ports, and not beyond 2 m.

Metallic components of outside-plant optical cables should not extend into the EEE beyond the connection to the bonding-bus without interruption of electrical continuity. If such components are interrupted and extended into the EEE, they should be connected to the bonding-bus at the terminating equipment.

In an EEC, the bond between the metallic components of an outside-plant cable and the bonding-bus should be as close to the entry port as practical.

7.4 Equipment framework

All frames, racks and metallic enclosures in an EEE should be bonded to the interior bonding-bus. Metallic hardware, such as framing channels, air ducts, and permanently installed access ladders, should also be bonded together as well as to the bonding-bus.

7.5 Surge protectors on communication pairs

If surge protectors are used on communication pairs, the common terminals of the protectors should be connected to the Main Earthing Terminal. The metallic screens of cables entering the protector frames should be bonded to the common terminals of the protectors.

7.6 Metallic walls

Metallic walls of an EEE should be bonded to the interior bonding-bus.

References

- [1] ITU-T Recommendation K.27 (1996), *Bonding configurations and earthing inside a telecommunication building*.
- [2] ITU-T Recommendation K.31 (1993), *Bonding configurations and earthing of telecommunication installations inside a subscriber's building*.
- [3] ITU-T Recommendation K.11 (1993), *Principles of protection against overvoltages and overcurrents*.
- [4] ITU-T Recommendation K.20 (1993), *Resistibility of telecommunication switching equipment to overvoltages and overcurrents*.
- [5] IEC Publication 364, *Electrical installations of buildings*.
IEC Publication 364-4-41 (1992), *Protection against electric shock*.
IEC Publication 364-5-54 (1980), *Earthing arrangements and protective conductors*, Amendment 1, 1982.
- [6] IEC Publication 50, *International electrotechnical vocabulary*; Chapter 826, 1990 and Chapter 604, 1987.
- [7] IEC Publication 364-4-444 (1996), *Electrical installations of buildings*.

Appendix I

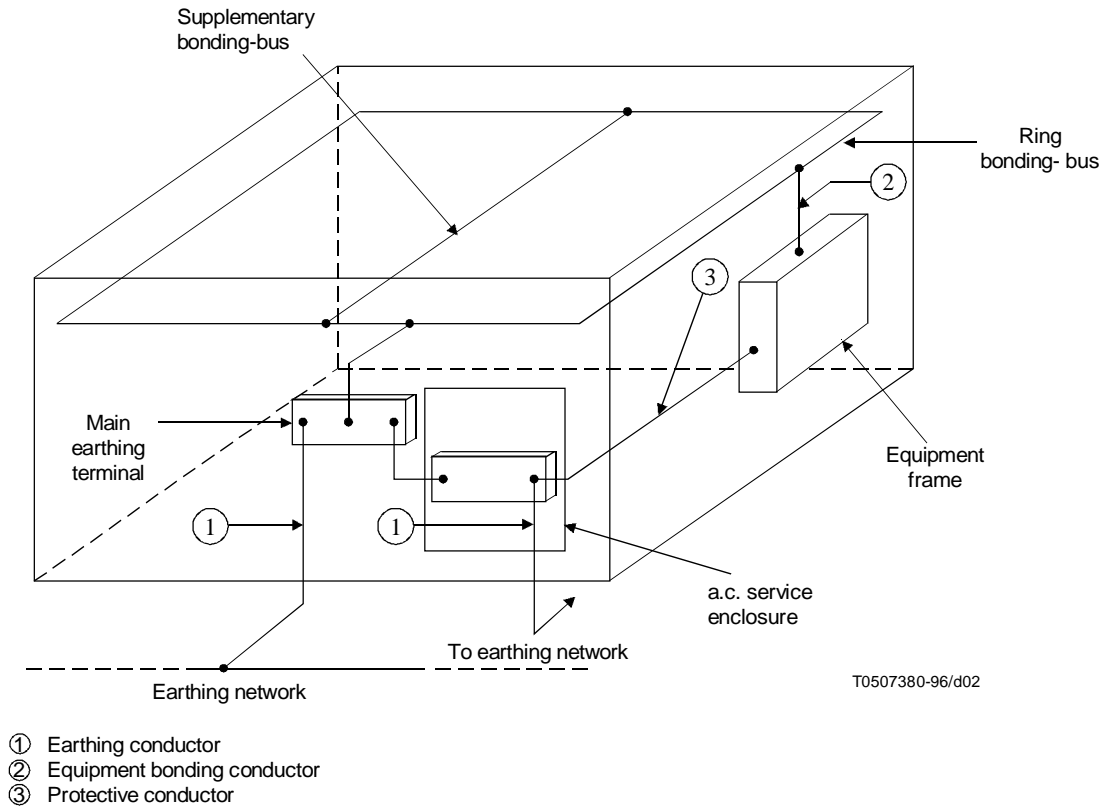

FIGURE I.1/K.35

Example of bonding configurations and earthing of EEEs by use of ring bonding-bus