



INTERNATIONAL TELECOMMUNICATION UNION

ITU-T

TELECOMMUNICATION
STANDARDIZATION SECTOR
OF ITU

K.31

(03/93)

PROTECTION AGAINST INTERFERENCE

**BONDING CONFIGURATIONS AND EARTHING
OF TELECOMMUNICATION INSTALLATIONS
INSIDE A SUBSCRIBER'S BUILDING**

ITU-T Recommendation K.31

(Previously "CCITT Recommendation")

FOREWORD

The ITU Telecommunication Standardization Sector (ITU-T) is a permanent organ of the International Telecommunication Union. The ITU-T is responsible for studying technical, operating and tariff questions and issuing Recommendations on them with a view to standardizing telecommunications on a worldwide basis.

The World Telecommunication Standardization Conference (WTSC), which meets every four years, established the topics for study by the ITU-T Study Groups which, in their turn, produce Recommendations on these topics.

ITU-T Recommendation K.31 was prepared by the ITU-T Study Group V (1988-1993) and was approved by the WTSC (Helsinki, March 1-12, 1993).

NOTES

1 As a consequence of a reform process within the International Telecommunication Union (ITU), the CCITT ceased to exist as of 28 February 1993. In its place, the ITU Telecommunication Standardization Sector (ITU-T) was created as of 1 March 1993. Similarly, in this reform process, the CCIR and the IFRB have been replaced by the Radiocommunication Sector.

In order not to delay publication of this Recommendation, no change has been made in the text to references containing the acronyms "CCITT, CCIR or IFRB" or their associated entities such as Plenary Assembly, Secretariat, etc. Future editions of this Recommendation will contain the proper terminology related to the new ITU structure.

2 In this Recommendation, the expression "Administration" is used for conciseness to indicate both a telecommunication administration and a recognized operating agency.

© ITU 1994

All rights reserved. No part of this publication may be reproduced or utilized in any form or by any means, electronic or mechanical, including photocopying and microfilm, without permission in writing from the ITU.

CONTENTS

	<i>Page</i>
1 Introduction	1
2 Scope	1
3 Definitions	1
4 Objectives for bonding configurations and earthing	2
5 a.c. power distribution	2
6 Principles for equipotential bonding	2
7 Large installations	3
References	6
Appendix I – Examples of mitigation measures for installations of types TN-C and TN-CS	7

BONDING CONFIGURATIONS AND EARTHING OF TELECOMMUNICATION INSTALLATIONS INSIDE A SUBSCRIBER'S BUILDING

(Helsinki, 1993)

1 Introduction

The increasing use of complex electronic telecommunications equipment, such as ISDN terminals, at subscribers' buildings entails special care for protecting against electromagnetic disturbances. Such disturbances include exposure of the serving telecommunications cable to lightning and faults on the external power system, as well as protection against electrostatic discharges and radiated electromagnetic interference. Properly configured equipotential bonding within the building helps to achieve the necessary protection, while also helping to assure the safety of those using terminal equipment.

Recommendation K.27, "Bonding configurations and earthing inside a telecommunication building" is not generally applicable to installations within a subscriber's building, wherein several utilities may share a bonding configuration with little overall control by the telecommunications service-provider. Therefore, this Recommendation is intended for subscribers' buildings, including residential and commercial installations. This Recommendation does not fully cover power production and distribution plants.

2 Scope

This Recommendation:

- is a guide to bonding and earthing of telecommunication equipment in residential and commercial subscribers' premises;
- is intended to comply with IEC [1] or national standardizing bodies on a.c. power installations;
- is intended for use with new installations as well as for expansion and replacement of existing installations;
- is intended to encourage planning for electromagnetic compatibility, which should include bonding and earthing arrangements that accommodate installation tests and diagnostics;
- does not necessarily provide protection for the installation in the case of a direct lightning stroke to the building;
- is not intended to replace national regulations on bonding configurations and earthing.

For required values of immunity to surge currents and electrostatic discharges, see Recommendation K.21, "Resistability of subscribers' terminals to overvoltages and overcurrents" and Recommendation K.22, "Overvoltage resistability of equipment connected to an ISDN T/S bus". Permissible levels of electromagnetic emissions are covered by CISPR [2], or by national regulations. Concerning the need for overvoltage protectors, see Recommendation K.11, "Principles of protection against overvoltages and overcurrents", and national regulations.

3 Definitions

In this Recommendation, definitions with respect to earthing already introduced by the IEC [3] are used to maintain conformity. Definitions relating to bonding configurations and earthing in Recommendation K.27 also apply.

The signal earth conductor (SE) is used for the purpose of allowing the intended signalling function of telecommunication equipment to be fulfilled. The signalling function may include signalling with earth return. The function of a protective earth conductor (PE) and of a SE conductor may be comprised simultaneously by one and the same conductor, if it is designed to the rules imposed on it by safety requirements.

4 Objectives for bonding configurations and earthing

The purpose of bonding configurations and earthing of telecommunications systems at a subscriber's premises is to:

- 1) promote safety by reducing potentials between telecommunications equipment units and earthed systems;
- 2) mitigate damage caused by lightning and other surges on the mains and telecommunications cables;
- 3) facilitate rapid de-energization of main lines that accidentally contact telecommunications equipment or cable, thereby reducing hazard and damage;
- 4) provide paths to divert to earth the surge currents entering the premises on cable screens;
- 5) provide a low-resistance circuit to earth for systems that use signalling with earth return.

5 a.c. power distribution

The a.c. power installation in a subscriber's building is according to one of the types described in IEC [4]. EMC performance of telecommunication equipment is eased if the a.c. power installation inside a subscriber's building is of type TN-S as described by the IEC [1]. This power configuration requires that there be no PEN conductor within the building. If power is served to the subscriber's building by an IT or TT distribution network, the PE conductor inside the building is connected to the main earthing terminal, but the neutral conductor is not. If an IT or TT distribution network is equipped with a separation transformer dedicated to that building (e.g. to mitigate interference), or equivalent, it would allow the procedures of a TN-S installation to be followed. It is recognized that installations within a building with a TN-C section are in widespread use; however, bonding configurations and earthing for such an installation are a subject for further study. If a mains installation with a PEN conductor is used, attention is drawn to the possibility of overheating SE conductors or associated elements (e.g. contacts in a wall outlet); unwanted noise coupling to the telecom installation may also occur. Although the measures to be used with TN-C and TN-CS installations are still under study several Administrations have reported acceptable results using the mitigation measures described in Appendix I.

6 Principles for equipotential bonding

Equipment and persons in a building are exposed to externally produced energy because conductive services such as telecommunications lines, power lines, antenna leads, waveguides, earthing conductors, and metallic pipes penetrate the shell of the building. The penetration of conducted energy is mitigated by interconnecting all of these conductors at their entry points with low-impedance bonding conductors or voltage-limiting devices referred to the main earthing terminal.

Low impedance may be achieved by keeping the length of bonding conductors short. Similarly, the leads of voltage-limiting devices should be short.

Emphasis is on equipotential bonding of the telecommunications system to the PE of the power system. The resistance of the earthing network is of importance for systems that use signalling with earth return. In this case, an SE is used for connection to the earthing network. A common bonding network may provide the SE function.

It is desirable that the ingress for all conductors entering the premises (including the earthing conductor) be located close together. In particular, the a.c. power entrance facilities, telecommunication cable entrance facilities and the earthing conductor entry point shall be close together. Electromagnetic coupling between unshielded power cables and telecommunication cables may have to be considered.

The building should be provided with a main earthing terminal, located as close as possible to the a.c. power and telecommunication cable entrance facilities. The main earthing terminal may be a designated connection provided for the purpose, or other connections may be used, e.g. metallic waterpipe or conductor to the earthing system. In order to minimize surge currents and voltages in the building, the shields of all cables entering the building shall be bonded to the main earthing terminal, preferably directly or by means of monitoring current interrupters. Arresters or capacitors may be used for this connection, if required by corrosion considerations.

If protectors are installed on the telecommunications lines, they should be located as close as practicable to the location at which the lines enter the premises. By also locating the protectors near the entrance of the power mains, the length of the earthing conductor from the protector to the main earthing terminal is minimized. The low impedance of a short earthing conductor helps reduce surge voltage differences between the telecommunications lines and the protective conductor of the power system. It is recognized that, in some countries, the earthing terminal of the telecommunications line protectors is connected only to a separate earth electrode. It is recommended that over a transition period the separate earth electrodes should be interconnected.

In cases where earthing of a protector or cable screen of a cable entering the building is required, an accessible earthing network at the premises should be available for this purpose.

Additional surge protectors are sometimes installed at the location of the telecommunications terminal equipment in order to limit surges caused by coupling within the building. The common terminal of these protectors should be connected to the protective conductor near the protected equipment. (See 1.4.5/K.11 regarding use of secondary protectors.)

Figure 1 provides an example of a bonding configuration and earthing inside a subscriber's building. Figure 2 provides an example for an ISDN installation. For a given installation, the principles illustrated by these examples may be simplified or made more complex depending on the nature of the telecommunications terminal and its connections.

7 Large installations

Large installations of telecommunications equipment may require special care to avoid damage or upset from electromagnetic sources. Such installations should make use of the bonding configurations and earthing techniques of Recommendation K.27.

Some installations at subscribers' premises may consist of several buildings, with the telecommunications cable from the public network entering the first building then continuing to the other buildings. In that case, with the following exception, the telecommunications equipment of each building should be earthed and protected as in the previous case for an individual building. In the case where the inter-building cabling is not exposed to contact from a high voltage power line, and the distance between buildings is less than 50 m, and the cable between the buildings has a metallic screen connected to the earthing terminal of each building, protection is placed in the first building and no protector is needed at the second building. The restriction to 50 m is intended to provide a low probability of direct lightning stroke to the cable between the two buildings. This case is illustrated in Figure 3. Note that if the buildings of Figure 3 are not interconnected by the neutral or PE conductor of the a.c. power system, the addition of a conductor that connects the earthing networks of the buildings reduces the current in the metallic screen of the telecommunication cable.

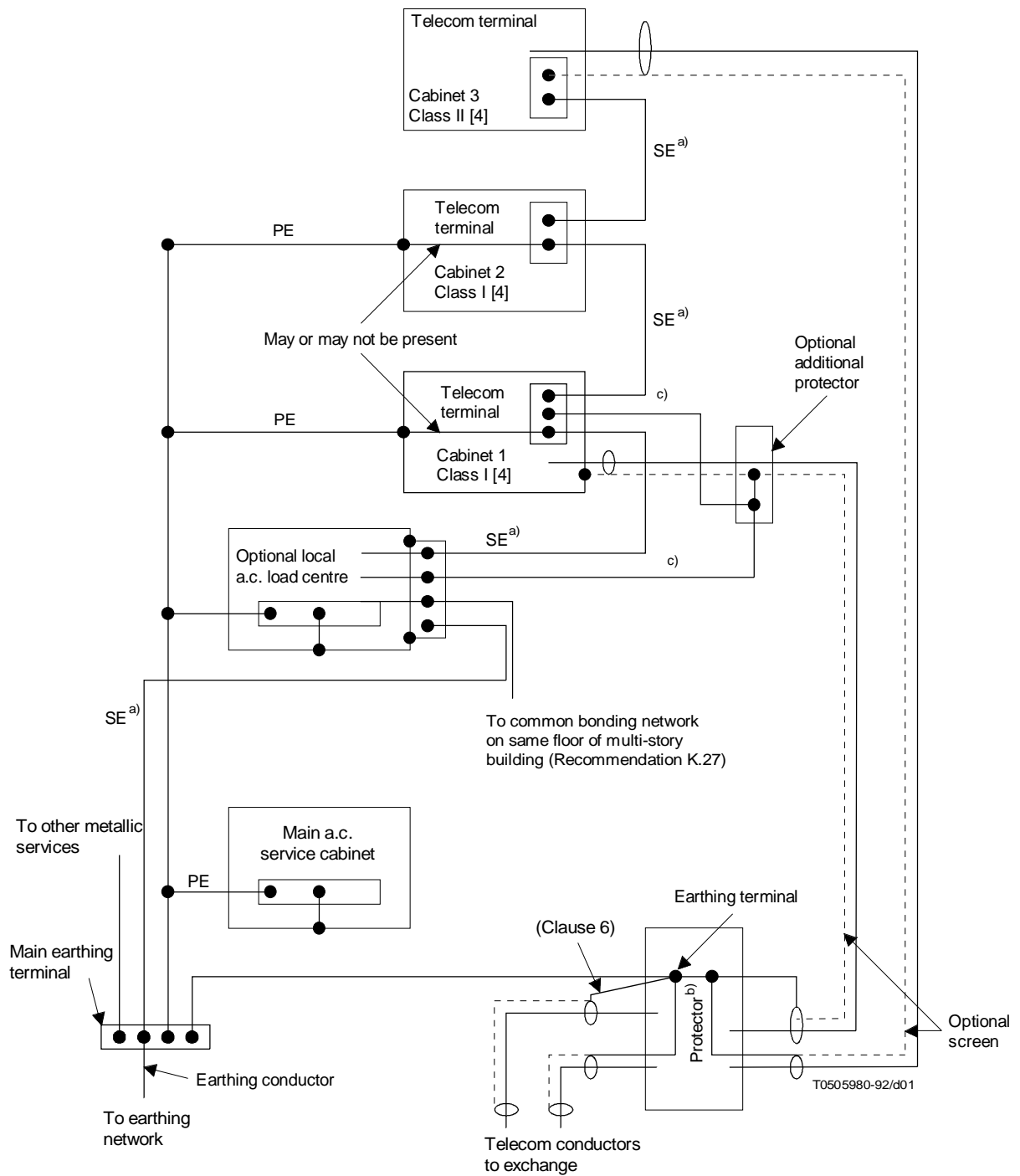

PE Protective Earth Conductor
 SE Signal Earth Conductor

- a) Optional for equipment using earth return signalling.
- b) If required (see Recommendation K.11).
- c) Alternative routings.

FIGURE 1/K.31
 Example of a bonding configuration and earthing inside
 a subscriber's building

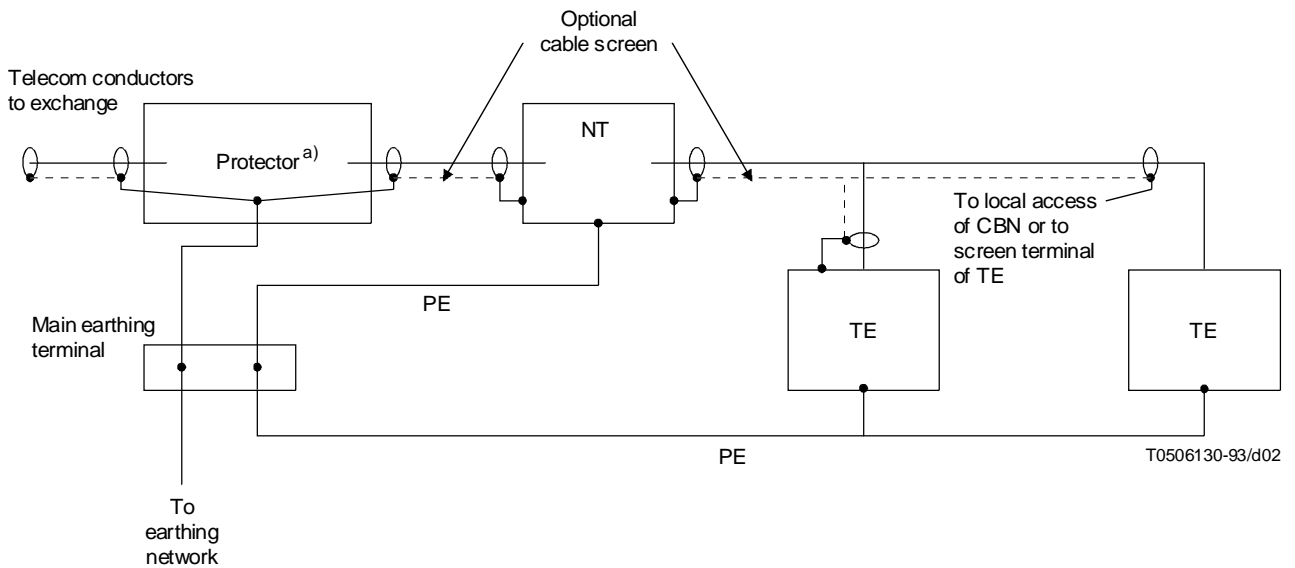

CBN Common bonding network (see Recommendation K.27)
 PE Protective earth conductor
 NT Network termination
 TE Terminal equipment

a) If required (see Recommendation K.11)

NOTE – If NT and TE have non-conducting cases, then the PE is not connected to the case.

FIGURE 2/K.31
**Example bonding configuration and earthing
 for an ISDN installation**

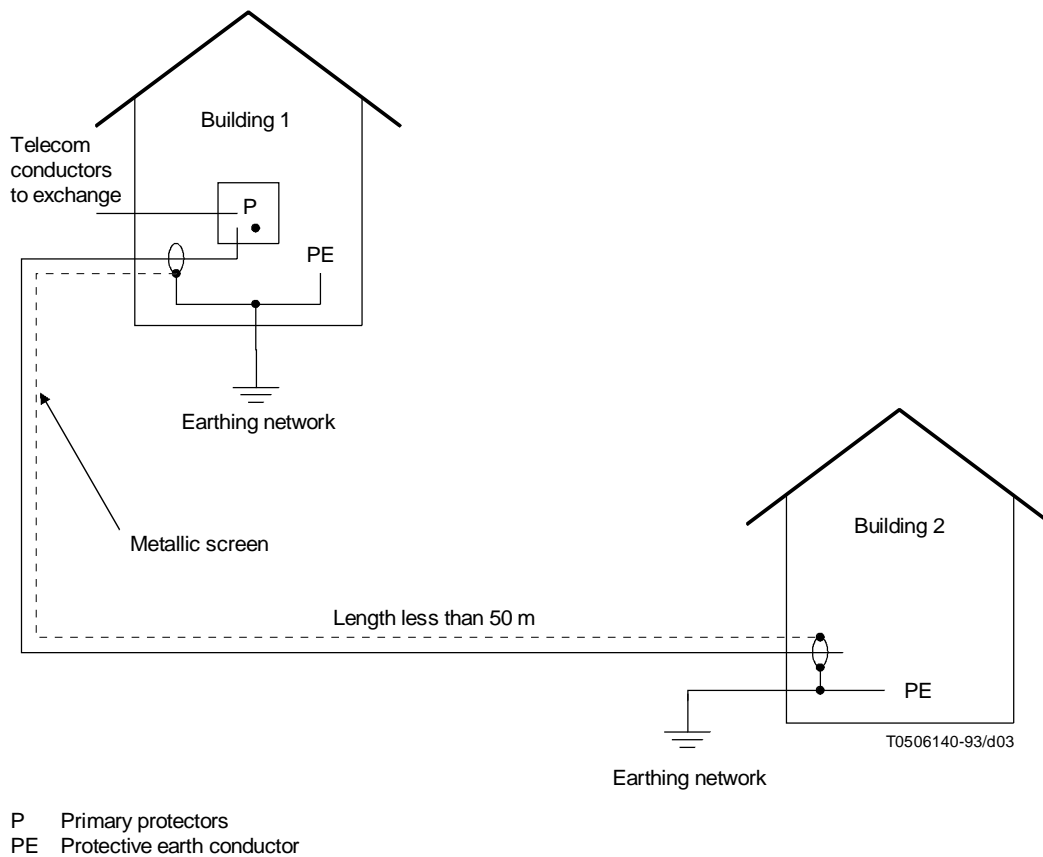

FIGURE 3/K.31

Electrical protection and earthing for nearby buildings using co-located primary protectors

References

- [1] IEC Publication 364-5-54 [1980] *Earthing Arrangements and Protective Conductors*, Amendment of 1982.
- [2] *Limits and Methods of Measurement of Radio Interference Characteristics of Information Technology Equipment*, CISPR Publication 22, International Electrotechnical Commission.
- [3] *International Electrotechnical Vocabulary*, IEC Publication 50, Chapters 604 and 826.
- [4] IEC Publication 364-3 *Electrical Installations of Buildings, Part 3: Assessment of General Characteristics*, 1977.

Appendix I

Examples of mitigation measures for installations of types TN-C and TN-CS

(This appendix does not form an integral part of this Recommendation)

Where existing installations inside a building are of the TN-C or TN-CS type, the following mitigation measures (either one alone or in combination) may be applied:

- 1) metal-free fibre optic cables for signal links interconnecting Class I equipment;
- 2) Class II equipment (double insulation, no PE conductor)¹⁾;
- 3) local separation transformers to supply telecommunications Class I equipment¹⁾;
- 4) suitable cable routing in order to minimize the enclosed area of common loops formed by the mains and signal cables;
- 5) additional screening²⁾.

¹⁾ In order to prevent low frequency interference currents through the equipment and its connected signal cables. These currents may be caused either by large loops or by the lack of a sufficiently low impedance CBN. If Class II equipment is not available, a separation transformer serves the same purpose.

²⁾ Additional screening (e.g. interconnected metal duct) also provides a lower impedance CBN.