



INTERNATIONAL TELECOMMUNICATION UNION

ITU-T

TELECOMMUNICATION
STANDARDIZATION SECTOR
OF ITU

K.17

PROTECTION AGAINST INTERFERENCE

**TESTS ON POWER-FED REPEATERS
USING SOLID-STATE DEVICES IN
ORDER TO CHECK THE ARRANGEMENTS
FOR PROTECTION FROM EXTERNAL
INTERFERENCE**

ITU-T Recommendation K.17

(Extract from the *Blue Book*)

NOTES

1 ITU-T Recommendation K.17 was published in Volume IX of the *Blue Book*. This file is an extract from the *Blue Book*. While the presentation and layout of the text might be slightly different from the *Blue Book* version, the contents of the file are identical to the *Blue Book* version and copyright conditions remain unchanged (see below).

2 In this Recommendation, the expression “Administration” is used for conciseness to indicate both a telecommunication administration and a recognized operating agency.

Recommendation K.17 ^{1), 2)}

TESTS ON POWER-FED REPEATERS USING SOLID-STATE DEVICES IN ORDER TO CHECK THE ARRANGEMENTS FOR PROTECTION FROM EXTERNAL INTERFERENCE

(Geneva, 1976, modified at Malaga-Torremolinos, 1984 and Melbourne, 1988)

1 Introduction

1.1 As pointed out in Recommendation K.15, § 4.1, it is advisable that the test conditions simulate real conditions as closely as possible. As certain Administrations may be exposed to different environments, or have different service objectives or economic constraints, these tests may be modified to adapt them to conditions.

If the environment is not known, the text given in this Recommendation should be applied.

1.2 None of the tests given in this Recommendation should cause any significant change in the in the characteristics concerning the repeaters under test.

In particular, this applies for:

- a) current and voltage in the feeding circuit,
- b) gain-frequency characteristic,
- c) total noise,
- d) bit error rate.

The tests consist of:

- prototype tests,
- acceptance tests.

Tests are intended to check the effectiveness of all the various arrangements made to protect repeaters using solid-state devices. These arrangements include protective devices incorporated as an integral part of the repeater or installed externally at the repeater location.

1.3 *Prototype tests*

Prototype tests are carried out to check the effectiveness of the repeater design and protective elements in a severe environment.

In deciding what protective measures should be adopted, allowance should be made for the most dangerous e.m.f.s that may be produced at the inputs and outputs of repeaters using solid-state devices, even where the occurrence of such e.m.f.s is very rare.

When a repeater using solid-state devices with lightning protectors at its input (or output) terminals is subjected to an impulse voltage, the (residual) energy capable of reaching components within the time-interval from zero to an impulse voltage, the (residual) energy capable of reaching components within the time-interval from zero to the striking-time of the lightning protectors depends, among other things, on the steepness of the impulse wave-front.

During the prototype test this residual energy should be as large as in the worst case that may be expected in practice.

This is ensured by choosing an impulse wave of suitable steepness and amplitude. It is, however, additional to the test described previously, which recommends that the repeater be subjected to an impulse having an amplitude less than the striking voltage of the lightning protectors, in order to find out how it responds over the whole of the impulse wave.

¹⁾ See also Recommendations K.15 and K.16.

²⁾ The tests specified in Recommendation K.17 can also be applied in a similar manner to terminal equipment, e.g. locally-fed repeaters, power separating filters, power feeding equipment, which are all affected in the same way as intermediate repeaters.

1.4 Acceptance tests

These tests are carried out on equipment after assembly, to check that the protection is working properly. The test is in general less severe than the prototype test in order to avoid exposing certain components to a degradation that might remain undetected by any measuring process. However, users are at liberty to stipulate more stringent tests (adapted to special, real conditions).

The user may decide whether the tests are to be carried out on each equipment or by sampling.

Note – In certain circumstances, users may consider it worthwhile to carry out additional tests adapted to their own special requirements. Such tests are not given below.

2 Testing methods

2.1 Testing methods concerning the protection of repeaters against overvoltages resulting from lightning (impulse tests)

Tests will be carried out with a device of the type described in Figure 1/K.17. The values for components C_2 and R_3 are given in Table 1/K.17. Capacitor C_1 will have to withstand a charging voltage equal to the peak voltage value given in Table 1/K.17.

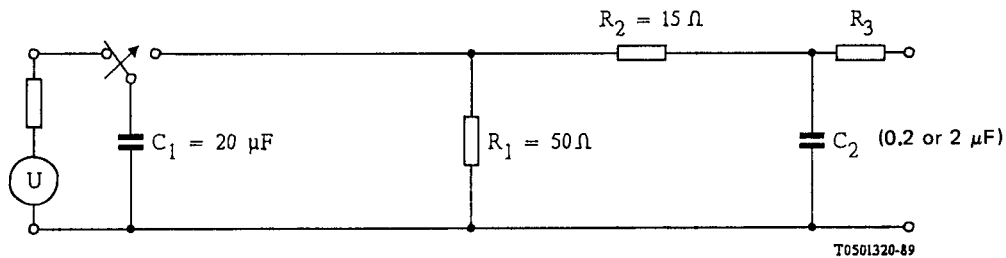

FIGURE 1/K.17

Diagram of an impulse generator

Note – When symmetric-pair (balanced) or μ coaxial-pair amplifiers are to be tested the short-circuit current of the testing equipment should be limited to adequate values by R_3 , considering the higher conductor resistances of symmetric-pair and μ coaxial-pair lines in comparison to lines in coaxial-pair cables.

The waveforms given in the table are in accordance with the definitions in [1] (the voltages and waveforms refer to a generator without load).

TABLE 1/K17

Characteristics of waveforms to be used for the tests

	Coaxial-pair repeaters ($\geq 1.2/4.4$ mm)				Symmetric-pair repeaters				μ coaxial-pair repeaters (0.7/2.9 mm)			
	Prototype tests		Acceptance tests		Prototype tests		Acceptance tests		Prototype tests		Acceptance tests	
	Test 1 Test 2	Test 3 ^{a)}	Test 1 Test 2	Test 3 ^{a)}	Test 1 Test 1a Test 2 Test 2a	Test 3	Test 1 Test 1a Test 2 Test 2a	Test 3	Test 1 Test 2	Test 3 ^{a)}	Test 1 Test 2	Test 3 ^{a)}
Column No.	(1)	(2)	(3)	(4)	(5)	(6)	(7)	(8)	(9)	(10)	(11)	(12)
Waveform ^{b)}	10/700	10/700	100/700	100/700	10/700	10/700	100/700	100/700	10/700	10/700	100/700	100/700
Load	0.1 coulomb	max. 0.1 coulomb	0.06 coulomb	max. 0.06 coulomb	0.03 coulomb	0.03 coulomb	0.03 coulomb	0.03 coulomb	0.1 coulomb	max. 0.1 coulomb	0.06 coulomb	max. 0.06 coulomb
Peak voltages	5 kV	5 kV	3 kV	3 kV	1.5 kV	1.5 kV	1.5 kV	1.5 kV	5 kV	5 kV	3 kV	3 kV
Short-circuit current	333 A		200 A		37.5 A		37.5 A		125 A		75 A	
Peak current in the power-feeding circuit		50 A		50 A		37.5 A		37.5 A		50 A		50 A
C_2	0.2 μ F	0.2 μ F	2 μ F	2 μ F	0.2 μ F	0.2 μ F	2 μ F	2 μ F	0.2 μ F	0.2 μ F	2 μ F	2 μ F
R_3	c)	c)	c)	c)	25 Ω	25 Ω	25 Ω	25 Ω	25 Ω	25 Ω	25 Ω	25 Ω
Number of pulses	10	10	2	2	10	10	2	2	10	10	2	2

a) For Test 3 on coaxial-pair repeaters, the peak voltage may be reduced to such a value as to cause not more than 50 A to flow.

b) Approximate values (see also the *Note* under § 2.1 in the text).

c) Resistor R_3 (0-2.5 ohms) may be introduced to prevent oscillatory discharge. It may be greater than 2.5 ohms if C_2 and R_2 are adjusted to maintain the waveform under load.

The tests are carried out with the polarity reversed at consecutive pulses, with a time interval of one minute between pulses; the number of pulses applied to each test point in the different cases is given in the bottom line of Table 1/K.17. Impulse waves should be applied at the following points:

- *Test 1*: at the input of the repeater, with the output terminated by its characteristic impedance;
- *Test 1a*: between input terminals of the repeater and conductive housing normally connected to earth in the case of symmetric pair repeaters;
- *Test 2*: at the output of the repeater, with the input terminated by its characteristic impedance;
- *Test 2a*: between output terminals of the repeater and conductive housing normally connected to earth in the case of symmetric pair repeaters.
- *Test 3*: (longitudinal) between the input-side inner conductor and the output-side inner conductor of the repeater in the case of coaxial-pair repeaters (at the terminals of the feeding circuit, in the case of symmetric-pair repeaters).

Equipments protected with arresters and installed on symmetrical pair cables, which are induced by a.c. power or traction lines, can be tested with an alternating current, applied for 0.5 second. Current intensity and frequency are comparable to the alternating currents that are likely to be encountered in practice, but should not exceed 10 A r.m.s.

Power should be supplied to the repeater during Tests 1, 1a, 2 and 2a, but not for Test 3.

For these tests the circuit arrangement given in Figure 2/K.17 for coaxial pairs and in Figure 3/K.17 for symmetric pairs may be found helpful. To couple the impulse generator to the repeater, lightning protectors with a striking voltage of approximately 90 V may be used, as illustrated in Figures 2/K.17 or 3/K.17, respectively.

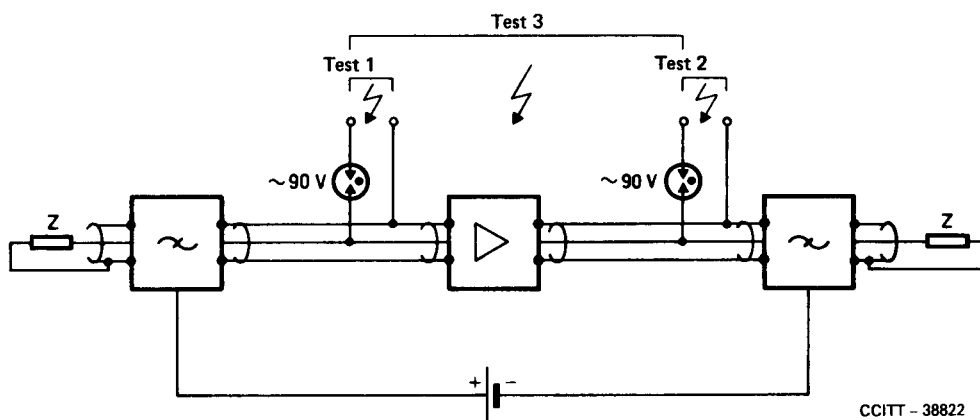

Note – The value of *Z* will be chosen in conformity with the system under test.

FIGURE 2/K.17

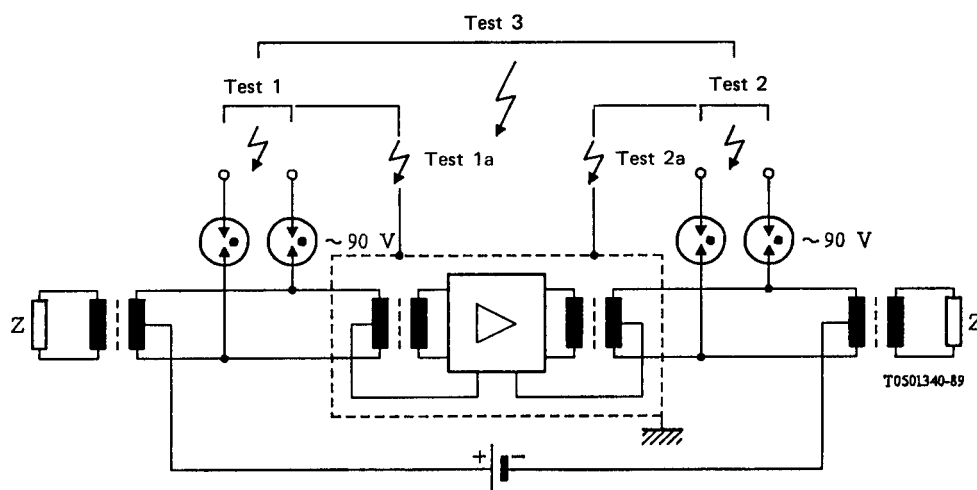

Note – The value of Z will be chosen in conformity with the system under test.

FIGURE 3/K.17

Example of circuit arrangement for impulse voltage test for power-fed repeaters used on symmetric-pair cables

2.2 Testing methods concerning the protection of repeaters against a.c. induction caused by a fault in a power line

2.2.1 A.c. tests on the input and output terminals of a repeater

An alternating e.m.f. (source frequency 16 2/3, 25, 50 or 60 Hz) is applied:

- across the repeater input, the output being terminated with an impedance twice the characteristic impedance;
- across the repeater output, the input being terminated with an impedance twice the characteristic impedance.

The value, the duration and the internal impedance of the e.m.f. source must be representative of local conditions. (This test is only specified for coaxial-pair repeaters).

2.2.2 A.c. tests on the terminals of the power-feeding path of the repeater

An alternating current of the appropriate frequency and value is fed into the terminals of the power feeding path.

If the additional stress from the application of power feeding is negligible, power feeding should not be applied during tests specified under § 2.2. However, if this stress is not negligible, the highest level of power feeding stress should be simulated during the a.c. test.

2.3 Testing methods concerning the protection for repeaters against disturbances resulting from the presence of alternating longitudinal e.m.f.s permanently induced by electricity lines

For satisfactory operation in the presence of steady-state induced voltages (see Recommendation K.15, § 3.2) the hum modulation characteristics of the repeaters should, as specified in Recommendation K.15, § 4.3, meet the recommendations for route sections prepared by Study Group XV and the repeater should operate without significant change to its transmission performance (for example, see the Recommendation cited in [2]) when connected to a typical power-feeding circuit in the presence of:

- a) an alternating voltage of the appropriate frequency (50 Hz, 16 2/3 Hz, etc.) applied to:
 - i) the signal input terminals, or
 - ii) the signal output terminals.

The source of this alternating voltage shall have, at the points of connection to the test circuit, such an impedance as not significantly to disturb the transmission-frequency characteristics of the circuit.

- b) an alternating current of the appropriate frequency superimposed on the power-feeding current of the repeater.

The test specified in a) must be performed with 60 V or 150 V according to the limits of permanently induced e.m.f. (see [3]). The test specified in b) must be performed with a current value corresponding to an e.m.f. of 60 V or 150 V calculated according to Recommendation K.16 and assuming the most adverse situation.

3 Tests to be carried out for the different cases

3.1 Test conditions for repeaters used on coaxial pairs

The following tests were formulated for the case where the outer conductor is connected to the metallic cable sheath. This covers the case where the outer conductor (normally at a floating potential) comes accidentally into contact with the metallic sheath.

3.1.1 Prototype tests

3.1.1.1 Tests at the input and output terminals of the repeater

3.1.1.1.1 Impulse tests

These tests will be carried out under conditions listed in Column 1 of Table 1/K.17.

If protection is ensured by *operating threshold* type devices (e.g., lightning protectors) at the input and output of the repeater and they do not strike under the above test conditions, the charging voltage of the capacitor, C_1 , should be gradually increased (though not beyond 7 kV³⁾) until they do so.

If protectors do not strike at 7 kV, or if the repeaters subjected to prototype tests are not provided with lightning protectors, the waveform suggested above may not be suitable. A pulse shape which simulates a breakdown in the cable can be produced by the test generator already mentioned above when a spark gap of the proper striking voltage is connected across the circuit. Where lightning protectors are provided, and if the strike under the above test conditions, the charging voltage of the capacitor, C_1 , should be gradually decreased until they do not strike.

3.1.1.1.2 A.c. tests⁴⁾

A voltage having an r.m.s. value which will produce 1200 V across a resistor of 150 ohms shall be applied for 0.5 seconds at:

- the input of the repeater, with the output terminated by a resistor of 150 ohms,
- the output of the repeater, with the input terminated by a resistor of 150 ohms.

The impedance of the source of voltage be such that any current which flows, lies between 8 A and 10 A.

The e.m.f. of the source of the voltage be such that when it is loaded with a resistor having a value of 150 ohms, a voltage of at least 1200 V r.m.s. appears across the load resistor. An example of a test circuit suitable for a frequency of 50 Hz is shown in Figure 4/K.17.

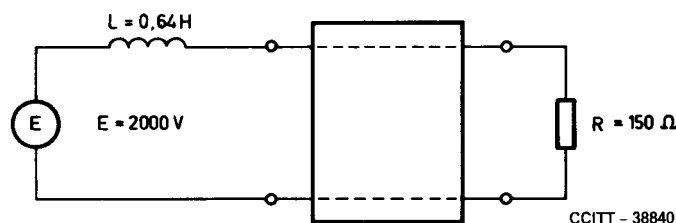

FIGURE 4/K.17
Example of test circuit for a.c. tests at 50 Hz

3.1.1.1.3 Steady-rate a.c.-induced voltage tests

These tests should be carried out in accordance with § 2.3 above.

³⁾ If repeaters used for μ coaxial-pairs are tested, the maximum peak voltage need not exceed 5 kV.

⁴⁾ This parts of the Recommendation may be modified following future studies and tests. If an Administration considers that these values are too high for its requirements in view of the local conditions concerned, a lower value may be specified.

3.1.1.2 *Test at the terminals of the repeater power-feeding circuit*

3.1.1.2.1 *Impulse tests*

These tests will be carried out under conditions listed in Column 2 of Table 1/K.17.

In this test the capacitor, C_1 , may be charged either at 5 kV or at a lower voltage provided the peak current in the power-feeding circuit reaches 50 A.

3.1.1.2.2 *A.c. tests*

These tests consist in passing an alternating current, comparable in intensity and frequency to the alternating currents that are likely to be met with in practice, through the power-feeding circuit. The current should be applied for 0.5 sec., but should not exceed 10 A.r.m.s.

3.1.1.2.3 *Steady-state a.c.-induced voltage tests*

These tests should be carried out in accordance with § 2.3 above.

3.1.2 *Acceptance tests*

3.1.2.1 *Tests at the input and output terminals of the repeater*

These tests will be carried out under conditions listed in Column 3 of Table 1/K.17.

3.1.2.1 *Tests at the terminals of the power-feeding circuit of the repeater*

These tests will be carried out under conditions listed in Column 4 of Table 1/K.17. In this test, the capacitor, C_1 , may be charged either at 3 kV, or at a lower voltage, provided the peak current in the power-feeding circuit reaches 50 A.

3.2 *Test conditions for repeaters used on symmetric pairs*

3.2.1 *Prototype tests*

3.2.1.1 *Tests at repeater input and output terminals*

3.2.1.1.1 *Impulse tests*

These tests will be carried out with a waveform having the characteristics listed in Column 5 of Table 1/K.17.

Where the dielectric strength of the symmetric pairs is greater than that of paper-insulated pairs, it would be advisable to use a higher peak voltage than that shown in Table 1/K.17.

Where lightning protectors are provided and if they strike under the above test conditions, the charging voltage of the capacitor, C_1 , should be gradually decreased until they do not strike.

Note – When lightning protectors are placed the input and output terminals of the repeater and its chassis, one of the terminals should be connected to the chassis before making the transverse-voltage test to simulate striking of a lightning protector.

3.2.1.1.2 *A.c. tests*

A.c. tests are not specified.

3.2.1.2 *Tests at the terminals of the repeater power-feeding circuit*

3.2.1.2.1 *Impulse tests*

These tests will be carried out under conditions listed in Column 6 of Table 1/K.17.

3.2.1.2.2 *A.c. tests*

These tests consist in passing an alternating current, comparable in intensity and frequency to the to the alternating currents that are likely to be met with in practice, through the power-feeding circuit. The current should be applied for 0.5 second.

These tests may be omitted if the repeaters, in their environment, are not likely to experience longitudinal e.m.f.s induced by electricity lines which will produce the flow of longitudinal currents.

3.2.1.2.3 *Steady-state a.c.-induced voltage tests*

These tests should be carried out in accordance with § 2.3 above.

3.2.2 *Acceptance tests*

3.2.2.1 *Tests at the input and output terminals of repeaters*

These tests will be carried out under conditions listed in Column 7 of Table 1/K.17.

3.2.2.2 *Tests at the terminals of the power-feeding circuit*

These tests will be carried out under conditions listed in Column 8 of Table 1/K.17.

3.3 *Test conditions for regenerators and power feeding sources used on optical fibre transmission systems*

The following tests are applicable for all types of regenerators.

In principle two types of regenerators exist: Regenerators with housings on floating potential and regenerators with housings connected to local earth. The regenerators may also be power-fed via separate d.c.-converters. These stand-alone units may be also considered as one “regenerator” for the purposes of this Recommendation.

3.3.1 *Prototype tests*

3.3.1.1 *Impulse tests*

These tests will be carried out under conditions listed in column 1 of Table 2/K.17.

Tests should be applied to equipment as indicated in Figure 5/K.17.

- *Test 1:* between terminals *a* and *b* of the power feeding path;
- *Test 2:* between terminal *a* of power feeding path and reference earth;
- *Test 3:* between terminal *b* of power feeding path and reference earth;
- *Test 4:* between both terminals *a* and *b* of power feeding path and reference earth.

Earth connections of housings to reference earth should be the same as used in practice.

TABLE 2/K.17

Characteristic of waveforms to be used for impulse test of optical fibre systems

	Impulse tests	
	Prototype tests	Acceptance tests
	Test 1 Test 2 Test 3 Test 4	Test 1 Test 4
Column No.	(1)	(2)
Waveform	10/700	100/700
Load	0.1 coulomb	0.06 coulomb
Peak voltages	5 kV	3 kV
Short circuit current	333 A	200 A
C_2	0.2 μF	2 μF
R_3	2.5 Ω	2.5 Ω
Number of pulses	10	2

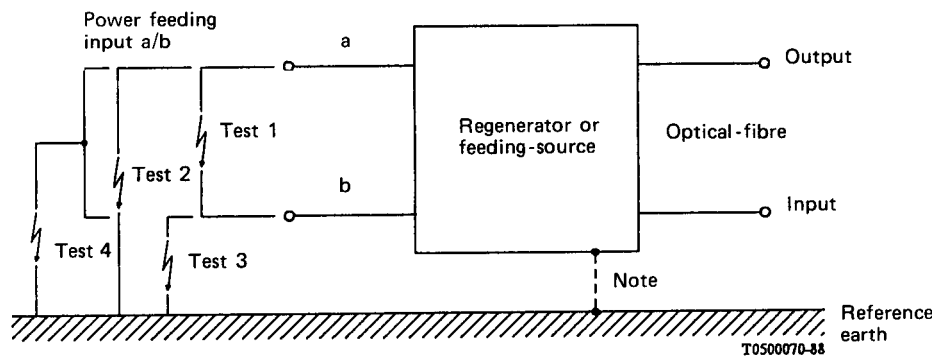

Note – Earth connection if existing in practice.

FIGURE 5/K.17

Circuit arrangements for impulse tests

3.3.1.2 *A.C. tests*

3.3.1.2.1 *Short-term a.c. induction*

These tests are carried out under conditions listed in Table 3/K.17.

Tests 1, 2, 3 and 4 should be applied to equipment as indicated in Figure 5/K.17 and explained in § 3.3.1.1.

TABLE 3/K.17

Currents and voltages for a.c. tests of optical fibre systems

	A.C. tests	
	Test 1	Test 2 Test 3 Test 4
Voltage		1200 V _{r.m.s.}
Current	10 A _{r.m.s.}	max. 10 A _{r.m.s.}
Duration	0.5 s	0.5 s
Number of tests	1	1

3.3.1.2.2 *Steady state a.c. induction*

These tests should be carried out in accordance with § 2.3 b) and equipment should operate during tests without significant increase of bit error rate.

3.3.1.3 *Immunity test against fast transients induced in the power feeding path*

These tests may be carried out to ensure the regenerator is sufficiently protected against transients occurring in the power feeding path.

These tests should be applied to equipment as indicated in Figure 6/K.17.

For testing, a generator according to IEC publication 801-4 should be used. At test voltages up to 1 kV the simulated signal transmission should not be disturbed severely. It is recommended to carry out this test if the power feeding path is not sufficiently shielded and interferences due to switching in electric power systems may be expected.

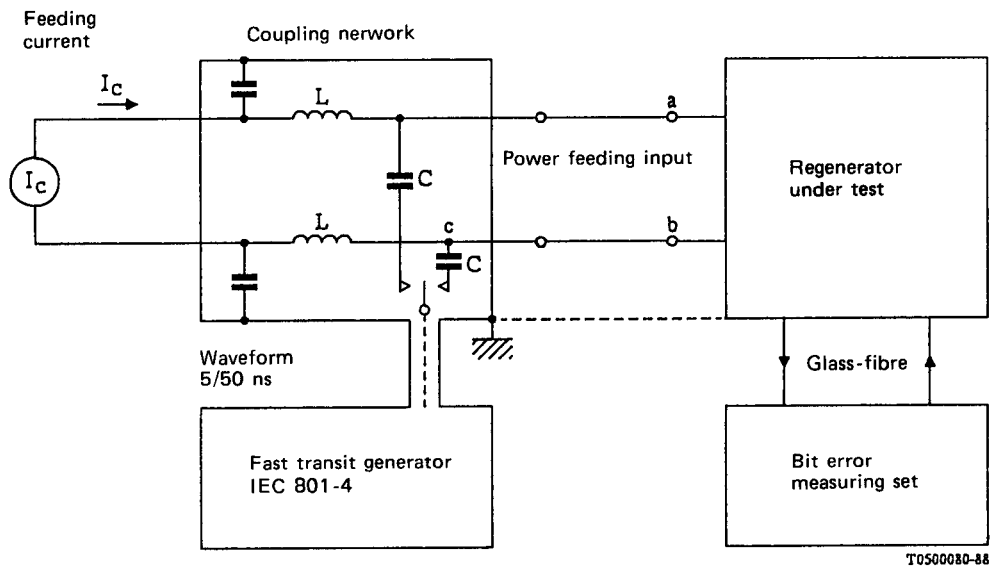

FIGURE 6/K.17

Immunity test for regenerators for glass-fibre systems

3.3.2 *Acceptance tests*

Only impulse tests will be carried out under conditions listed in column 2 of Table 2/K.17.

Tests 1 and 4 have to be performed into account the remarks given in § 1.4.

References

- [1] IEC publication No. 60-2 *High-voltage test techniques, Part 2: Test procedures*, Geneva, 1973.
- [2] CCITT Recommendation *Unwanted modulation and phase jitter*, Rec. G.229, § 1.3.
- [3] CCITT manual *Directives concerning the protection of telecommunication lines against harmful effects from electric power and electrified railway lines*, Vol. VI, ITU, Geneva, 1988.