



INTERNATIONAL TELECOMMUNICATION UNION

ITU-T

TELECOMMUNICATION
STANDARDIZATION SECTOR
OF ITU

K.16

PROTECTION AGAINST INTERFERENCE

**SIMPLIFIED CALCULATION METHOD FOR
ESTIMATING THE EFFECT OF MAGNETIC
INDUCTION FROM POWER LINES ON
REMOTE - FED REPEATERS IN COAXIAL
PAIR TELECOMMUNICATION SYSTEMS**

ITU-T Recommendation K.16

(Extract from the *Blue Book*)

NOTES

1 ITU-T Recommendation K.16 was published in Volume IX of the *Blue Book*. This file is an extract from the *Blue Book*. While the presentation and layout of the text might be slightly different from the *Blue Book* version, the contents of the file are identical to the *Blue Book* version and copyright conditions remain unchanged (see below).

2 In this Recommendation, the expression “Administration” is used for conciseness to indicate both a telecommunication administration and a recognized operating agency.

Recommendation K.16

SIMPLIFIED CALCULATION METHOD FOR ESTIMATING THE EFFECT OF MAGNETIC INDUCTION FROM POWER LINES ON REMOTE-FED REPEATERS IN COAXIAL PAIR TELECOMMUNICATION SYSTEMS

(Geneva, 1972)

1 Summary

The article mentioned in reference [1] contains a general treatise covering all possible cases of magnetic induction and permitting calculation of the location-dependent variation of the induced voltages and currents for full or partial exposure to induction of a route. This Recommendation gives general information on how to find an equivalent circuit which permits rapid estimation of the maxima of the voltages and currents in cable conductors for any length and location of exposure. The lumped capacitances and the transfer impedance of the equivalent circuit must be appropriately chosen. Only two groups of parameters are required here, depending upon whether the length of the exposed section is shorter than, or equal to, or greater than half the length of the power-feeding section. The manner of switching from the complex formulae given in [1] to the simplified calculation is explained in Annex A.

To check the usefulness of this universally applicable equivalent circuit, the maxima of the voltages and currents induced on the conductors of a cable when the outer conductors are at floating potential are calculated in Annex B for some of the exposure values evaluated numerically in the article mentioned above. They are also entered in the diagrams. It will be seen that the calculation procedure shown in this Annex B gives sufficiently accurate results for practical purposes.

Annex C shows how the equivalent circuit must be modified in cases where the outer conductors of the coaxial pairs are earthed at the terminals and at the repeater points.

A similar calculation method for the effects of magnetic induction of power lines on telecommunication systems installed on coaxial pair cables whose outer conductor is insulated is described in the article mentioned in reference [2].

2 Advantages of the equivalent circuit

One of the reference quantities in the exact formulae given in the two articles cited above is the longitudinal voltage induced in the cable. This can be calculated by the usual methods (see the CCITT *Directives*).

Once it is known, the induced voltages and currents can be numerically evaluated very precisely from the exact formulae, but the results approximate the actual values only in so far as this is permitted by the limited accuracy of the basic parameters used. Experience shows, however, that this accuracy is low since certain factors which cannot be accurately determined – such as the effective conductivity of the soil – play a considerable part.

In view of the unavoidable inaccuracy in calculating the induced longitudinal voltage used as reference quantity, a further error of up to about 20% is tolerated in the remainder of the calculation. The exact formulae can then be considerably simplified for all applications (since in practice $\Gamma \cdot l \leq 2$ and $\bar{\Gamma} \cdot l \leq 2$ nearly always holds) and corresponding equivalent circuits can be devised for each case. (The quantities Γ and $\bar{\Gamma}$ are the propagation constants of the circuits *cable sheath–outer conductor* and *outer conductor–inner conductor*, respectively.)

3 Statement of the problem

Equivalent circuits may be considered for the following cases of induction:

- 1) outer conductor earthed, uniform induction;
- 2) outer conductor at a floating potential, uniform induction (see Figure A-1/K.16);
- 3) outer conductor earthed, partial exposure on a short length at midroute;
- 4) outer conductor at a floating potential, partial exposure on a short length at midroute (see Figure A-2/K.16).

In practice it is much easier to deal with a single equivalent circuit instead of four. Moreover, it would be advantageous if, on the basis of the article mentioned in reference [1], a universally applicable uniform equivalent circuit could be devised which furnished sufficiently accurate information on the maxima of the voltages and currents induced on the cable even with an arbitrarily chosen partial exposure to induction of a power-feeding section.

As is shown in Annex A, such an equivalent circuit can be derived with the aid of the circuit diagrams shown in Figures A-1/K.16 and A-2/K.16. This circuit is shown in Figure 2/K.16.

4 Parameters and symbols employed

On the basis of the general assumption that a power-feeding section with the outer conductors at floating potential (not bonded to the cable sheath or to a grounding system) is exposed to induction along an arbitrarily located section, we can draw Figure 1/K.16 below, which shows the conventions and symbols employed.

The symbols denoting the quantities (E, C, V, I) associated with the circuit *cable sheath–outer conductor* will be written without a bar and all those ($\bar{E}, \bar{C}, \bar{V}, \bar{I}$) associated with the circuit *outer conductor–inner conductor* with a bar.

5 Universally applicable equivalent circuit

The arguments in Annex A make it possible to define a universal equivalent circuit (Figure 2/K.16).

For all long-distance communication systems with power-feeding sections that are either uniformly exposed to magnetic induction or partially exposed along a short central section this equivalent circuit furnishes the maxima of the voltages and currents induced in the two circuits in Figure 1/K.16, with an accuracy of about 10%. When this circuit is applied to other cases of exposure, deviations of up to about 20% from the theoretical values must be expected but this error rate may be tolerated in practice in view of the uncertainty in determining the induced longitudinal voltage E and because conditions can then be rapidly estimated.

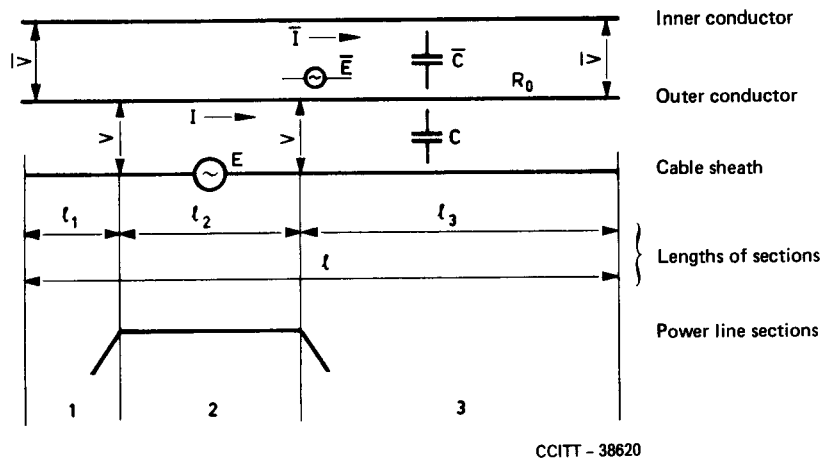

- E = longitudinal voltage induced in the cable (volts)
 - \bar{E} = longitudinal voltage in the coaxial tube (volts)
 - l_2 = length of the exposed section (km)
 - l_1, l_3 = lengths of the unexposed sections (km)
 - l = length of the power-feeding section (km) = $l_1 + l_2 + l_3$
 - V, \bar{V}, I, \bar{I} = maxima of the voltages and currents to be determined
 - C, \bar{C} = capacitances (F/km) effective per unit length
- where
- $C = \frac{C_{0s} \cdot l_s + C'_{0s}}{l_s}$ and $\bar{C} = \frac{C_{i0} \cdot l_s + C_f}{l_s}$
 - C_{0s} = capacitance per unit length between outer conductor and cable sheath (F/km)
 - C'_{0s} = capacitance between the outer-conductor and the cable sheath located at the repeater (if any) (F)
 - C_{i0} = capacitance per unit length between the inner and the outer conductor (F/km)
 - C_f = sum of all capacitances between the power-feeding path and the outer conductor in the power separating filters of a repeater (F)
 - l_s = length of repeater section (km)
 - Z_t = effective transfer impedance per unit length (Ω /km) between the circuit *cable sheath–outer conductor* and the circuit *outer conductor–inner conductor*
 - R_0 = resistance per unit length (Ω /km) of the outer conductor alone
 - R_i = resistance per unit length (Ω /km) of the inner conductor, to which a corrective term is added, which corresponds to the value, per km, of the resistance of the directional filters

FIGURE 1/K.16

Schematic representation of circuits

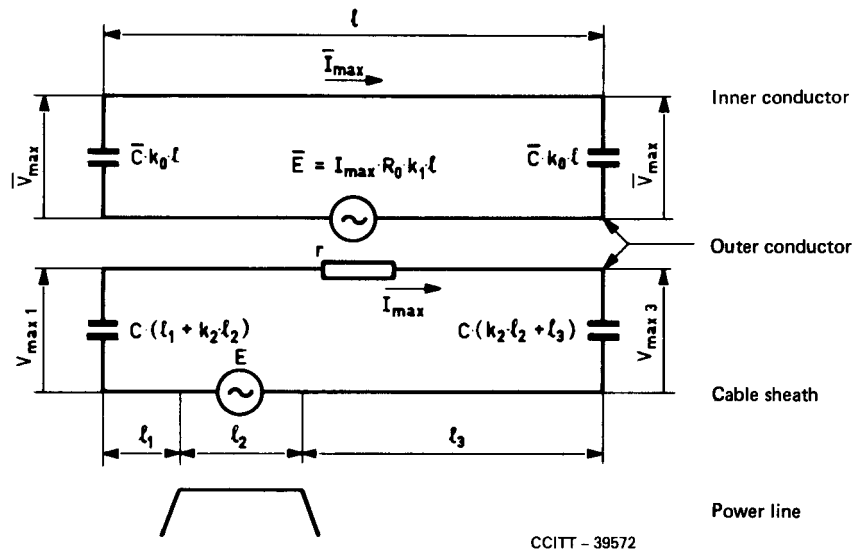

Value of parameters k			
	k_0	k_1	k_2
for $l_2 \leq \frac{l}{2}$	$\frac{1}{3}$	$\frac{1}{2}$	$\frac{1}{3}$
for $l_2 > \frac{l}{2}$	$\frac{5}{16}$	$\frac{2}{3}$	$\frac{1}{4}$

Note – The resistance r is to be considered only for earthed outer conductors (see Annex C).

FIGURE 2/K.16
Equivalent circuit

The following comments will help to explain the simplified diagram:

- 1) All the components of the real transmission lines are assumed to be concentrated, which is acceptable for a short line open at both ends, for a wavelength corresponding to 50 Hz.
- 2) The conductor resistance is not taken into account in the circuits, except for constituting the inter-circuit transfer impedance; it is introduced weighted by a coefficient k_1 which depends on the length of the section exposed and is such that $k_1 < 1$.

This implies that the circuits shown in Figure 2/K.16 are in fact open (for induced currents at 50 Hz) at the ends of the remote-feeding section. This may not be the case, particularly if the power supply equipments include filters and balancing devices to fix the inner conductor potentials in relation to the earth. The circuit *inner conductor–outer conductor* is then terminated across high-value capacitors which must be added in parallel at $C k_0 l$ at the two ends of Figure 2/K.16. In this case, the inner conductor series resistance cannot now be disregarded. A practical example is given in Annex C.

- 3) The capacitances $C l_1$ and $C l_3$ correspond to the precise terminal beyond the exposed section; the capacitance of the exposed section is introduced weighted by a coefficient k_2 which depends on the length of the exposed section and is such that $2 k_2 < 1$.
- 4) The simplified diagram gives rise to dissymmetrical voltages in the circuit *sheath–outer conductor*. It can be used to determine the maximum values at the ends. Figure 3/K.16 gives an idea, adequate for practical purposes, of the voltage and current throughout the remote-feeding section. The voltage varies little outside the exposed section and is zero near the middle of the exposed section; the current is obviously zero at the ends, since the circuit is open when the outer conductor is at floating potential.

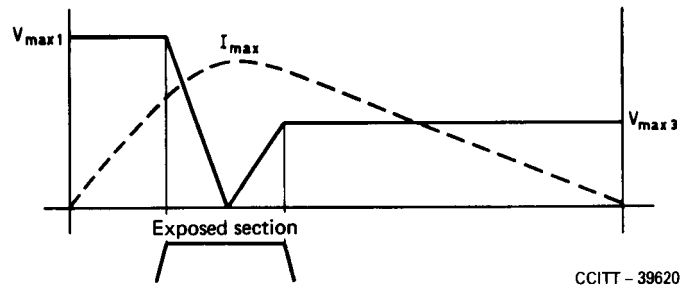

FIGURE 3/K.16

Voltage and current throughout the remote-feeding section in the circuit *sheath – outer conductor*

- 5) On the other hand, in the circuit *inner conductor–outer conductor* the voltage and current are much more symmetrical. The capacitance is weighted by a coefficient k_0 which depends on the length of the exposed section and is such that $2 k_0 < 1$.
- 6) The simplified diagram makes it possible to calculate, in the same way as in 4) above, the maximum voltage and current in the circuit *inner conductor–outer conductor*. Depending on the nature of the circuit, these values may be much lower than in the circuit *sheath–outer conductor*. Figure 4/K.16 gives an idea, adequate for practical purposes, of the voltage and current throughout the remote-feeding section. The extreme voltages are symmetrical, while the zero voltage and maximum current are always very near the middle of the remote-feeding section, irrespective of the position of the exposed section.

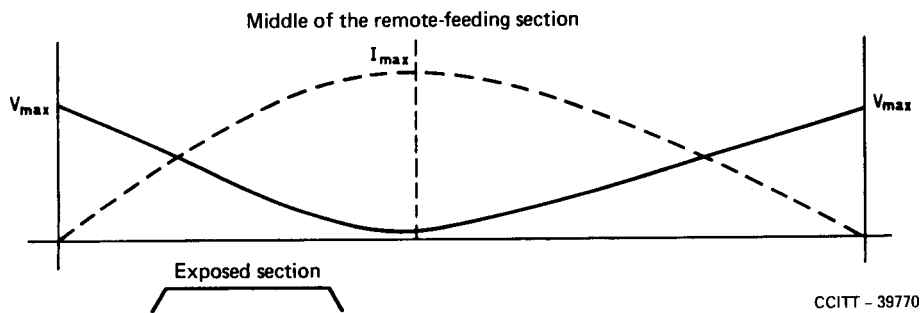

FIGURE 4/K.16

Voltage and current throughout the remote-feeding section in the circuit *inner conductor – outer conductor*

(to Recommendation K.16)

**Justification of the parameters included in the
universally applicable equivalent circuit**

A.1 *General case*

The article mentioned in reference [1] gives equation systems containing the complex transmission parameters of the two circuits in question.

These equations can be used to arrive at a complete solution of the problem of circuits open at both ends. These formulae develop a large number of terms into hyperbolic functions of complex parameters which make them inconvenient to apply in practice. Several approximation stages are required to arrive at a very simple diagram which can be used for an elementary calculation.

A.2 *First stage – Symmetrical exposure – Full calculation*

The general formulae are applied to two cases of symmetrical exposure, shown in Figures A-1/K.16 and A-2/K.16; in the first case, the exposure covers the entire remote-feeding section, while in the second case it is confined to a short length in the middle of the section. The curves plotted from the calculations are contained in reference [1] and are also shown in Figure B-1/K.16.

A.3 *Second stage – Symmetrical exposure – Simplified diagram*

Account is taken of the short electrical length of the lines and of the phase angle near $\pm 45^\circ$ of the secondary propagation parameters. This makes it possible to replace the distributed elements by capacitors and lumped resistances, shown in Figures A-1/K.16 and A-2/K.16. Coefficients such as $5/16$, $1/4$, $1/2$, $1/3$ derive from the series development of the complex hyperbolic terms.

The equivalent circuits in Figures A-1/K.16 and A-2/K.16 can be used to calculate the maximum voltages and currents in two cases of symmetrical exposure; since these cases are both extremely exceptional, we should, at the same time, consider the general case of a dissymmetrical exposure of any length. This is the subject of the following stage.

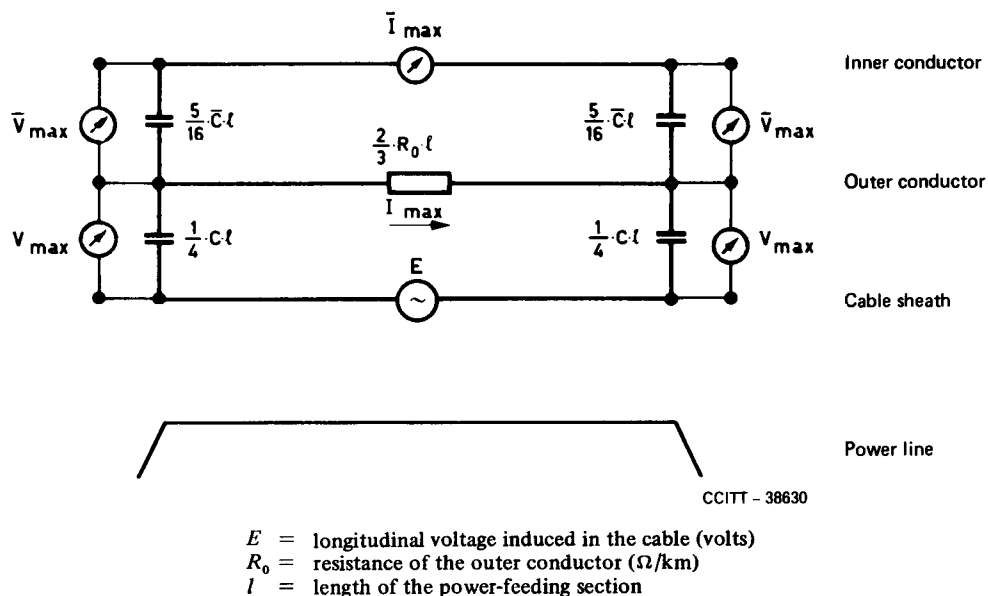
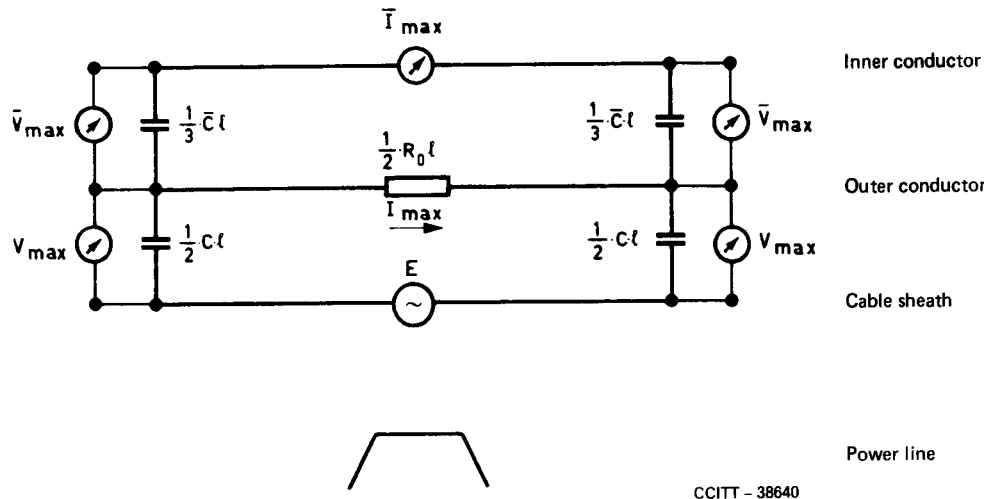

FIGURE A-1/K.16
Uniform exposure to induction of the power-feeding section



E = longitudinal voltage induced in the cable (volts)
 R_0 = resistance of the outer conductor (Ω/km)
 l = length of the power-feeding section

FIGURE A-2/K.16
 Partial exposure of short length in the middle of the section

A.4 Third Stage – General case – Simplified diagram

A.4.1 Circuit cable sheath – outer conductor

In the exposed section 2, of length l_2 , the circuit *cable sheath/outer conductor* can be treated as a 2-wire line exposed to uniform induction whose ends are terminated by the line capacitances of the adjacent unexposed sections 1 and 3.

If section 2 is far longer than the sections 1 and 3 ($l_2 \gg l/2$), the current and voltage distributions are mainly determined by the exposed section itself and they will therefore be almost or fully symmetrical with reference to the middle of the section. The effective capacitance values shown in Figure A-1/K.16 for the uniformly induced 2-wire line can then be inserted for section 2. The arrangement in Figure A-3/K.16 is then obtained for $l_2 \gg l/2$.

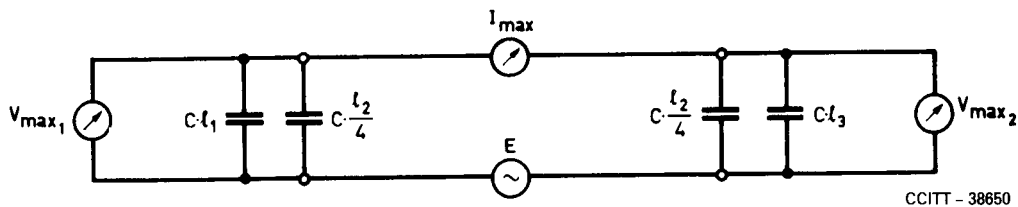

FIGURE A-3/K.16
 Circuit cable sheath – outer conductor – long exposed section

When, however, the exposed section is far shorter than the unexposed sections ($l_2 \ll l/2$) the current and voltage distribution will be mainly determined by the admittances at the section ends. The induced current maximum moves then towards that end of section 2 which is adjacent to the longer of the two unexposed sections. The largest displacement of the current maximum occurs when section 2 is located directly at the beginning or at the end of the power-feeding section ($l_1 = 0$ or $l_3 = 0$, respectively). In this limit case, the condition of l_2 approaches that of a uniformly induced 2-wire line with a short circuit at one end.

The following equivalent circuit (Figure A-4/K.16) will therefore be used to determine the maximum induced current.

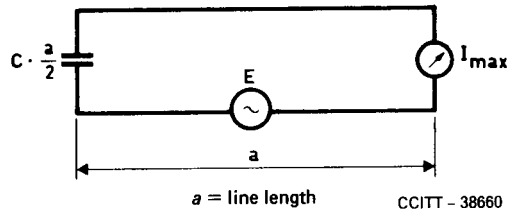

FIGURE A-4/K.16

Line with a short-circuit at one end

This circuit diagram is obtained from one half of the configuration in Figure A.1/K.16, showing a line of length $l = 2a$, with uniform induction and with both ends open, when a connection is established at midroute; this connection does not change the conditions.

Since, however, the end of section 2 is not short-circuited in the limit case under consideration, but is terminated by finite admittance ($\omega C \cdot l_3$ and $\omega C \cdot l_1$, respectively), the effective lumped capacitance $C \cdot l_2/x$ associated with section 2 in the partial equivalent circuit must range between the limits:

$$C \cdot \frac{l_2}{4} < C \cdot \frac{l_2}{x} < C \cdot \frac{l_2}{2} \quad \text{at the end with the shorter extension, and}$$

$$C \cdot \frac{l_2}{4} > C \cdot \frac{l_2}{x} > 0 \quad \text{at the other end.}$$

As will be shown subsequently, the assumption of $x = 3$ at each end is a compromise which gives satisfactory results for all locations of the short exposed section. The following configuration (Figure A.5/K.16) is then obtained for $l_2 \ll l/2$.

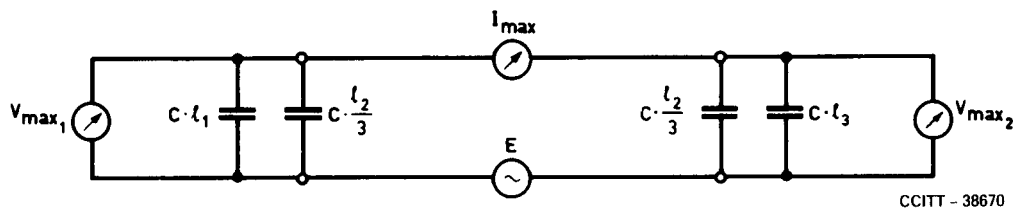

FIGURE A-5/K.16

Circuit cable sheath – outer conductor – short exposed section

A.4.2 Effective transfer impedance¹⁾

The current I flowing in the circuit cable sheath–outer conductor produces a longitudinal voltage \bar{E} across the resistance of the outer conductor in the coaxial system. This current I has a maximum in the exposed section and decreases to zero at the ends of the route. An effective resistance to be used with the maximum of I appears in the equivalent circuits derived from the simplified formulae. In the equivalent circuit method an effective resistance, designated by $Z_t \cdot l$, is called the effective transfer impedance. It replaces the resistance $R_0 \cdot l$. The value of \bar{E} is given by the equation: $\bar{E} = I_{\max} \cdot Z_t \cdot l$.

With uniform induction over the power-feeding section, as in Figure A-1/K.16, the value to be used for the transfer impedance is given by:

$$Z_t \cdot l = \frac{2}{3} \cdot R_0 \cdot l.$$

1) The transfer impedance is often also called the coupling impedance of the metallic cable sheath.

This value can also be inserted where the variation of the current I along the route is largely similar to that occurring with uniform induction ($l_2 \gg l/2$).

With a short partial exposure at the middle of the power-feeding section (see Figure A-2/K.16):

$$Z_t \cdot l = \frac{1}{2} \cdot R_0 \cdot l$$

must be used for the transfer impedance.

When the short partial exposure is located at the beginning or end of the power-feeding section, the same value is obtained (as can be proved from the equivalent circuit for a partial exposure at midsection, by inserting $2 \cdot l$ instead of l).

It can therefore be assumed that, as a first approximation, this value will not vary to any great extent even with an arbitrary location of the short exposed section.

The following values result accordingly for the transfer impedance of the equivalent circuit:

$$Z_t \cdot l = \frac{2}{3} R_0 \cdot l \text{ for } l_2 \gg \frac{l}{2} \text{ and}$$

$$Z_t \cdot l = \frac{1}{2} R_0 \cdot l \text{ for } l_2 \ll \frac{l}{2}$$

A.4.3 Circuit outer conductor-inner conductor

In the circuit *outer conductor-inner conductor* the longitudinal voltage \bar{E} extends over the full length of the power-feeding section even in the case of partial exposure. As can be gathered from the Figures in Annex B, the minimum of the voltage \bar{V} between the inner and the outer conductor appears exactly at midroute in the case of a symmetrical exposure and nearly at midroute in all cases of unsymmetrical exposures (even with extremely short induced sections at the beginning or end of the power-feeding section). The values calculated for current and voltage in the coaxial pair will therefore not change to any great extent, if it is assumed that the longitudinal-voltage field strength \bar{E}/l is symmetrically distributed irrespective of the length or location of the exposed section.

With this assumption the circuit diagrams in Figure A-6/K.16 derived from Figures A-1/K.16 and A-2/K.16 for symmetrical exposure can also be used, as a general rule, for any configuration.

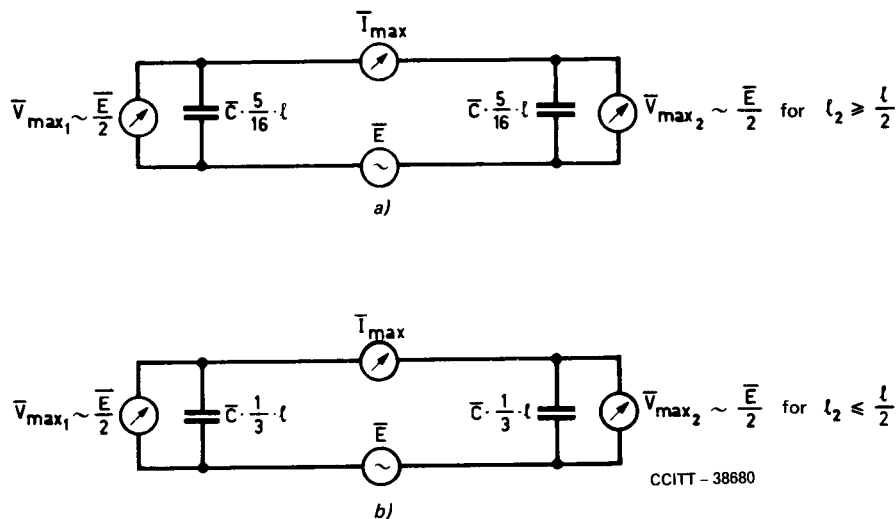

FIGURE A-6/K.16

Circuit outer conductor – inner conductor;
 a) long exposed section, b) short exposed section

A.5 Conclusion of Annex A

From the diagrams in Figures A-3/K.16 to A-6/K.16, a generally applicable equivalent circuit can be set up where the numerical values associated with the capacitances and the transfer impedance will vary according to the length of the exposed section:

$$l_2 \gg \frac{l}{2} \text{ and } l_2 \ll \frac{l}{2} \text{ respectively.}$$

As can be proven with numerical examples, satisfactory results are obtained by keeping the parameters associated with the case $l_2 \ll l/2$ even for $l_2 = l/2$. If then we replace:

$$l_2 \gg \frac{l}{2} \text{ by } l_2 > \frac{l}{2} \text{ and}$$

$$l_2 \ll \frac{l}{2} \text{ by } l_2 \leq \frac{l}{2}$$

the full range of all cases of exposure can be covered with two groups of parameters, leaving the error in the transition zone within tolerable limits.

The resulting generally applicable equivalent circuit is shown in Figure 2/K.16.

ANNEX B

(to Recommendation K.16)

Practical examples of complete calculations and of the simplified calculation. Case in which the outer conductors are at floating potential

To check the usefulness of this equivalent circuit for arbitrarily chosen partial exposures, the maxima of the voltages and currents were calculated by means of the equivalent circuit for some cases of exposures completely calculated in [1] and the values determined were entered in the corresponding diagrams reproduced from this reference.

The following values for a 300-channel system on small-diameter coaxial pairs were inserted for the comparative calculation:

$$C = 0.12 \text{ } \mu\text{F/km}; \quad R_0 = 6.2 \text{ } \Omega/\text{km} \quad \bar{C} = 0.2 \text{ } \mu\text{F/km}; \quad l = 64 \text{ km}$$

The curves of Figures 1 to 5 of this Annex, accurately plotted, show the voltages and currents induced in a 300-channel telecommunication system. These figures correspond to Figure 4/K.16 and Figures A-1/K.16 to A-3/K.16 of Annex A as reproduced from reference [1] except that a longitudinal voltage of $E = 1000 \text{ V}$, instead of 2000 V , was chosen as reference quantity. The approximate values of the maxima calculated with the equivalent circuit are indicated by black dots. The agreement with the values furnished by the exact analysis is satisfactory in all cases.

Example of calculation for Figure B-4/K.16 below

A 64-km power-feeding section of a 300-channel system on small-diameter coaxial pairs, whose outer conductor is at a floating potential, is assumed to be exposed to a power line between the 12th and the 28th kilometre. The longitudinal voltage in the cable is assumed to be 1000 V , 50 Hz . The maxima of the voltages and currents appearing in the cable have to be assessed.

There is thus $l_1 = 12 \text{ km}$, $l_2 = 16 \text{ km}$, $l_3 = 36 \text{ km}$, $l/2 = 32 \text{ km}$. Since $l_2 < l/2$, the following parameters for the equivalent circuit (see Figure 2/K.16) have to be applied: $k_0 = 1/3$, $k_1 = 1/2$, $k_2 = 1/3$. Other given parameters are: $\bar{C} = 0.2 \text{ } \mu\text{F/km}$, $R_0 = 6.2 \text{ } \Omega/\text{km}$, $C = 0.12 \text{ } \mu\text{F/km}$.

Calculation scheme:

$$Ck_2l_2 = 0.12 \times \frac{1}{3} \times 16$$

$$Cl_1 = 0.12 \times 12 = 1.44 \mu\text{F}$$

$$Cl_2 = 0.12 \times 12 = 1.44 \mu\text{F}$$

$$Cl_3 = 0.12 \times 36 = 4.32 \mu\text{F}$$

$$\underbrace{1.44 \mu\text{F} + 1.44 \mu\text{F}}_{2.08 \mu\text{F}}$$

$$\underbrace{4.32 \mu\text{F} + 1.44 \mu\text{F}}_{4.96 \mu\text{F}}$$

$$\frac{1}{\omega C} \text{ at 50 Hz: } 1530 \Omega + 640 \Omega = 2170 \Omega$$

$$I_{\max} = \frac{1000 \text{ V}}{2170 \Omega} = 0.461 \text{ A}$$

$$\begin{array}{l} \times \quad 1530 \Omega = V_{\max_1} = 705 \text{ V} \\ \times \quad 640 \Omega = V_{\max_2} = 295 \text{ V} \\ \times \quad 198.5 \Omega = \bar{E} = 91.6 \text{ V} \end{array}$$

$$\frac{1}{2} R_0 l = \frac{1}{2} \times 6.2 \times 64 = 198.5 \Omega$$

$$\frac{1}{2} \bar{E} \approx \bar{V}_{\max_1} \approx \bar{V}_{\max_2} = 45.8 \text{ V}$$

$$\frac{1}{3} \omega \bar{C} l = \frac{1}{3} \times 314 \times 0.2 \times 10^{-6} \times 64 = 1.34 \times 10^{-3} \text{ mhos}$$

$$\bar{I}_{\max} = 1.34 \times 10^{-3} \times 45.8 = 61.5 \text{ mA}$$

TABLE B-1/K.16

Comparison of the equivalent circuit determination with the accurately calculated maxima

(Values from Figure B-4/K.16)

Maxima	Exact calculation	Equivalent-circuit determination	Deviation from the exact calculation
V_{\max_1}	685 V	705 V	+2.9 %
V_{\max_2}	315 V	295 V	-6.3 %
I_{\max}	0.455 A	0.461 A	+1.3 %
\bar{V}_{\max_1}	48 V	45.8 V	-4.6 %
\bar{V}_{\max_2}	37.5 V	45.8 V	+22 %
\bar{I}_{\max}	55 mA	61.5 mA	+11.8 %

This comparison shows that, with the exception of the value of \bar{V}_{\max_2} , all deviations from the exact calculation remain below 12% and the equivalent circuit values are mostly greater than the exact values. The deviation of 22% in the case of \bar{V}_{\max_2} is of no practical importance since it involves the smaller of the two maxima of \bar{V} .

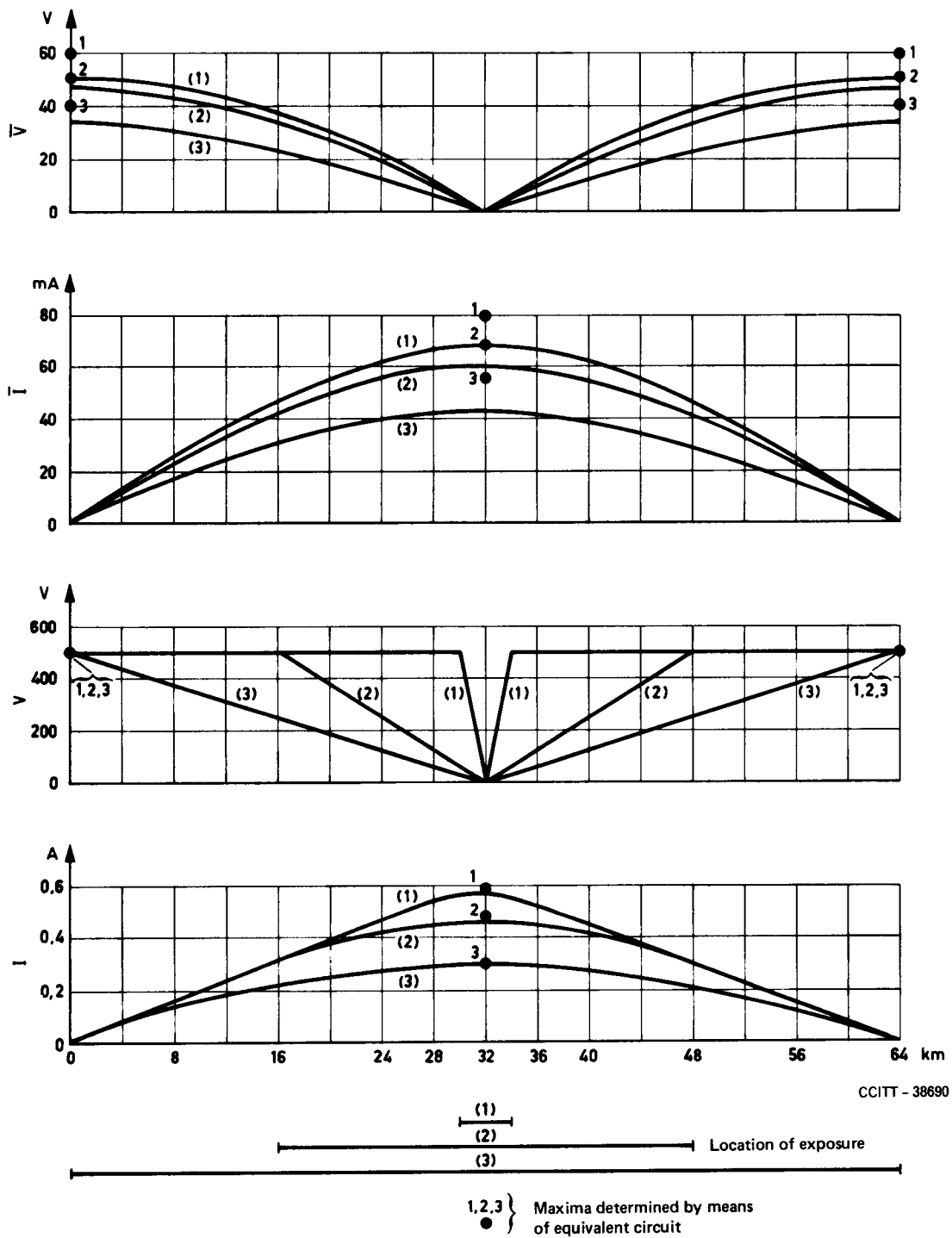

CCITT - 38690

FIGURE B-1/K.16

Voltages and currents for a 300-channel route with symmetrical exposures. Voltage induced along the exposed section: 1000 volts (outer conductors of coaxial pairs at floating potential)

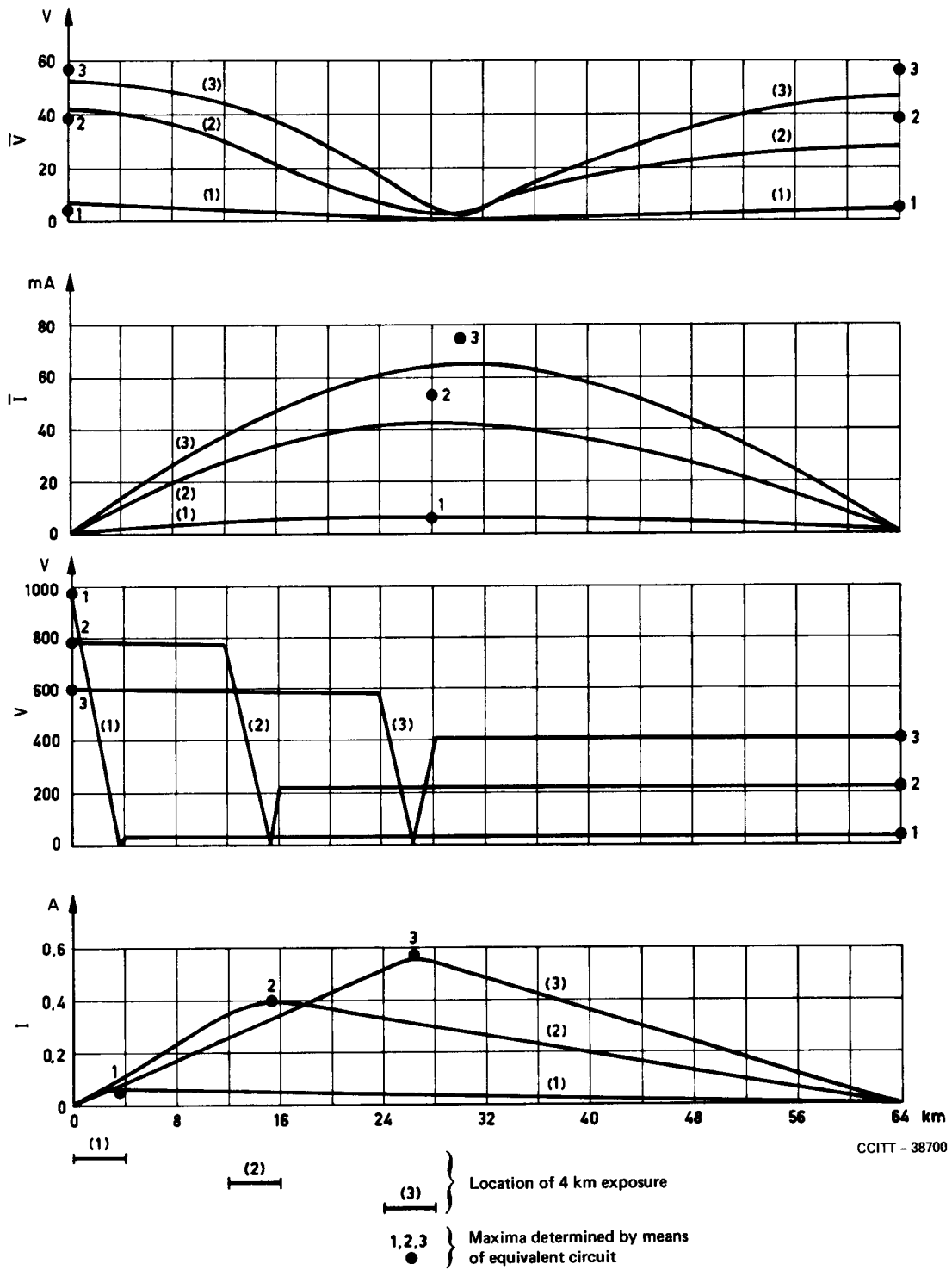
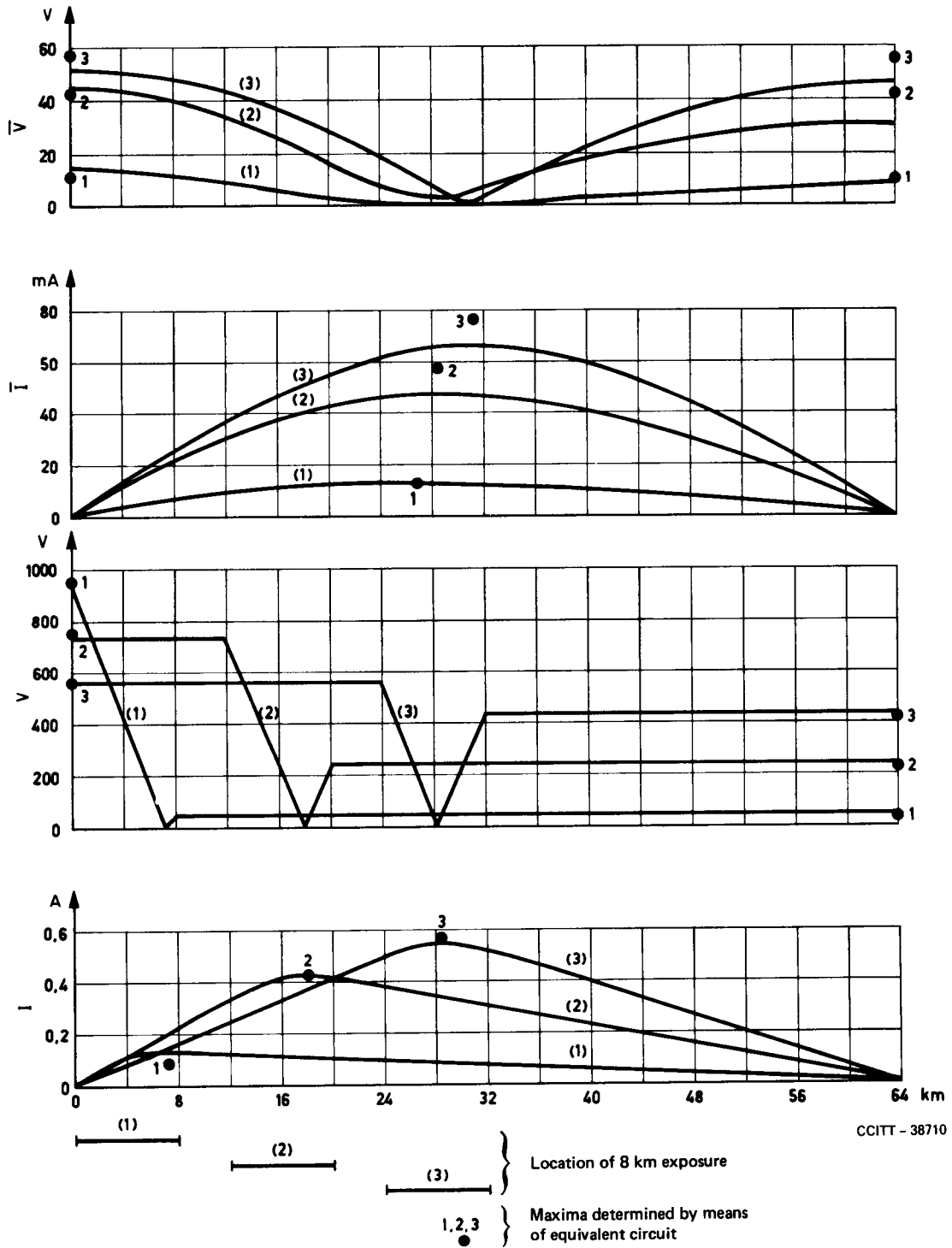

FIGURE B-2/K.16

Voltages and currents for a 300-channel route with asymmetrical exposures. Length of exposure 4 km. Voltage induced along the exposed section: 1000 volts (outer conductors of coaxial pairs at floating potential)



CCITT - 38710

FIGURE B-3/K.16

Voltages and currents for a 300-channel route with asymmetrical exposures. Length of exposure 8 km. Voltage induced along the exposed section: 1000 volts (outer conductors of coaxial pairs at floating potential)

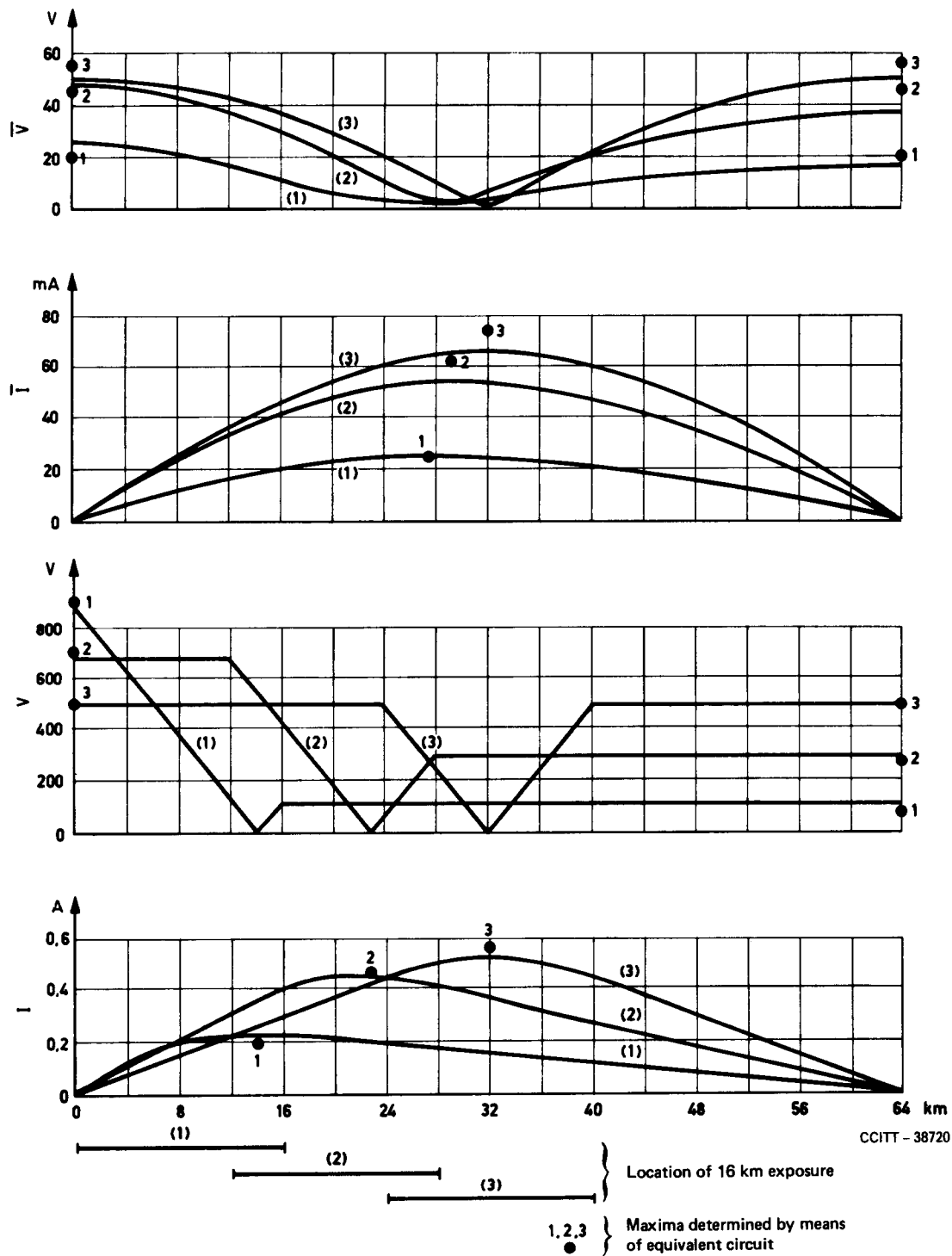

FIGURE B-4/K.16

Voltages and currents for a 300-channel route with asymmetrical exposures. Length of exposure 16 km.
 Voltage induced along the exposed section: 1000 volts (outer conductors of coaxial pairs at floating potential)

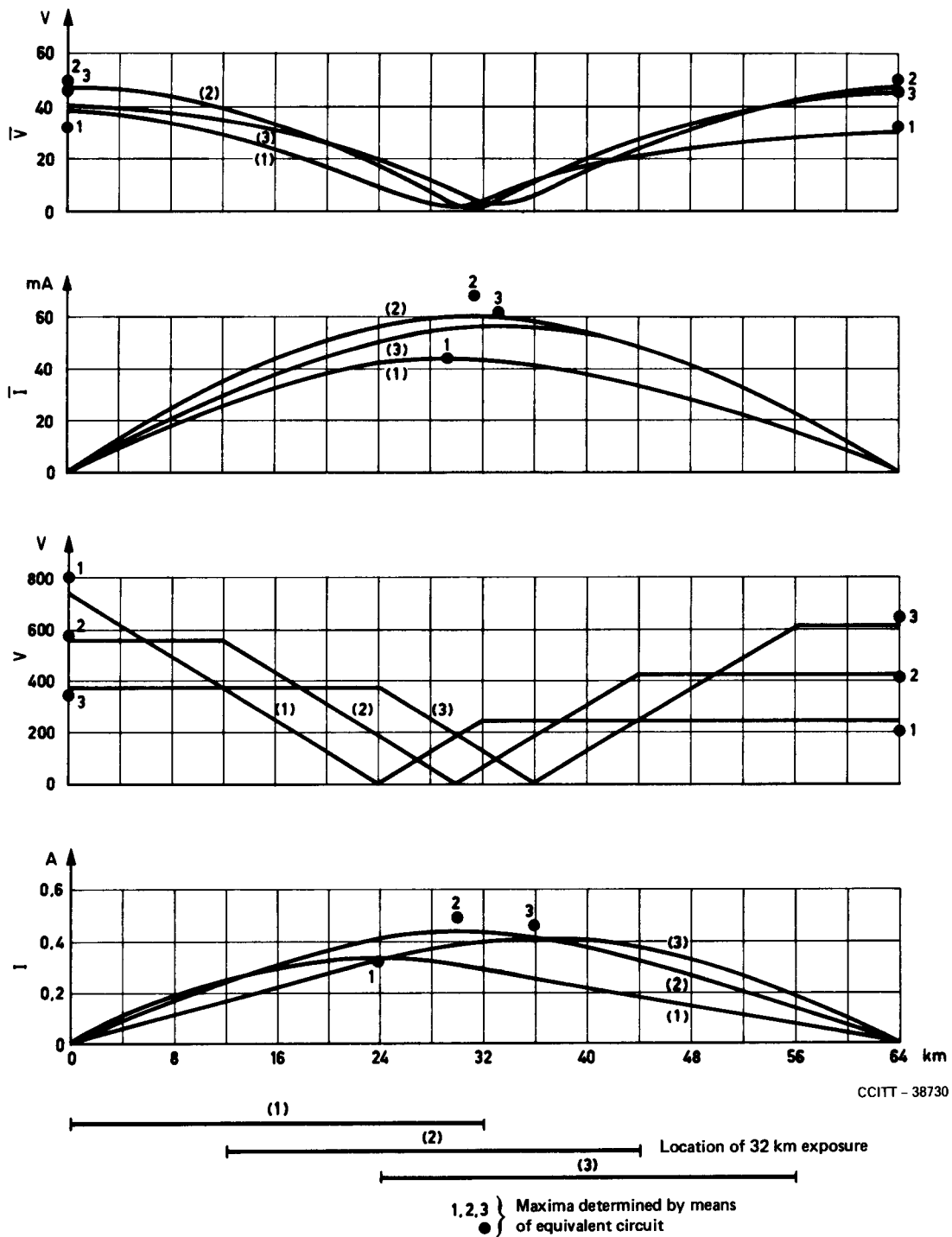

FIGURE B-5/K.16

Voltages and currents for a 300-channel route with asymmetrical exposures. Length of exposure 32 km. Voltage induced along the exposed section: 1000 volts (outer conductors of coaxial pairs at floating potential)

(to Recommendation K.16)

Practical examples of complete calculations and of the simplified calculation case in which the outer conductors are earthed

C.1 *Where the inner conductors are at a regulated potential, slightly decoupled*

For the case of earthed outer conductors and inner conductors at a regulated potential with low-value earth decoupling capacitors, only the part of the diagram simulating the circuit *outer conductor–inner conductor* must be considered in the equivalent circuit, inserting logically the capacitance \bar{C} instead of C . The resistance $k_1 R_0 l$ representing the transfer impedance is also omitted. The universal diagram is reduced in this case to the diagram shown in Figure C-1/K.16.

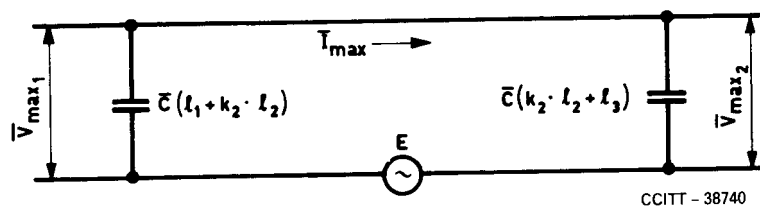

FIGURE C-1/K.16

Circuit cable sheath – outer conductor (long exposed section)

C.2 *Where the inner conductors are earthed through a low impedance in the power-feeding station*

The universal diagram is reduced in this case to the diagram shown in Figure C-2/K.16.

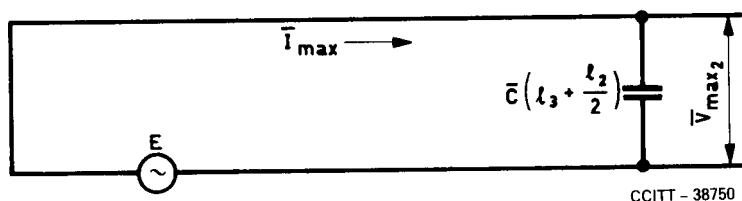

FIGURE C-2/K.16

Line with a short circuit at one end

C.3 *Where the inner conductors are at a regulated potential, strongly decoupled*

When the outer conductors are earthed and the inner conductors are connected to a regulated potential with powerful earth decoupling capacitors (several μF), the simplified diagram (Figure C-1/K.16) is insufficient. Account must also be taken of the resistance of the centre conductors of the coaxial pairs (possible resistances in series in repeater power feeds).

To ensure the validity of the equivalent circuit thus modified, a calculation was made using a definite example representing actual service conditions. The systems involved are still 300-channel small-diameter coaxial pair systems, this time involving a circuit 66 km long, with $\bar{C} = 0.11 \mu\text{F}/\text{km}$, $R_i = 17 \Omega/\text{km}$, the decoupling impedance of the regulated supply systems being equivalent to a resistance R_F of 50 ohms in series with a capacitance C_F of 15 μF . The diagram is shown in Figure C-3/K.16.

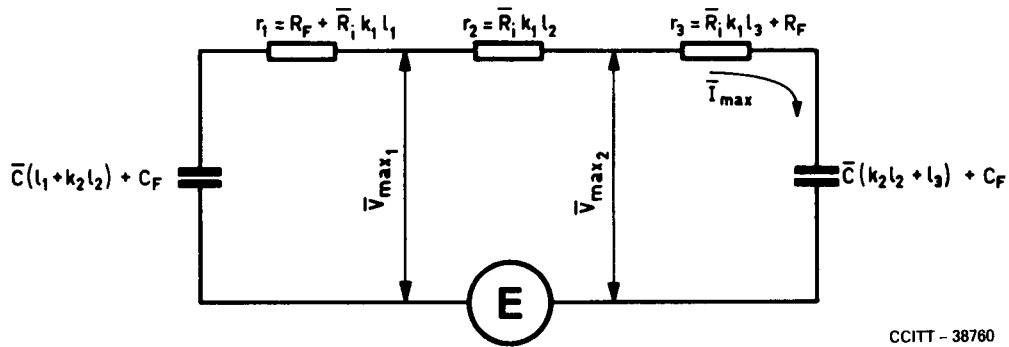

CCITT - 38760

Note - \bar{R}_i is the resistance per kilometre of the inner conductor plus the total resistance of all the repeater directional filters, expressed as a resistance value per kilometre.

FIGURE C-3/K.16

Equivalent circuit where the outer conductors of the coaxial pairs are earthed and the inner conductors have a strongly decoupled regulated feed

The induced voltage is assumed to be such that, taking account of the screening factor of the cable, the interference voltage to be considered is 100 V (if the voltage could not be restricted to such a value, another solution would be applied, reversion to the floating potential for example). For an induced voltage E of 100 V, after taking the combined screening factor of the cable sheath and the earthed outer conductors into account, Figures C-4/K.16 to C-7/K.16 below show the values of the voltages and currents obtained in the complete circuit; the points corresponding to the use of the equivalent circuit in Figure C-3/K.16 are plotted on these figures. Agreement between the two series of results is entirely satisfactory.

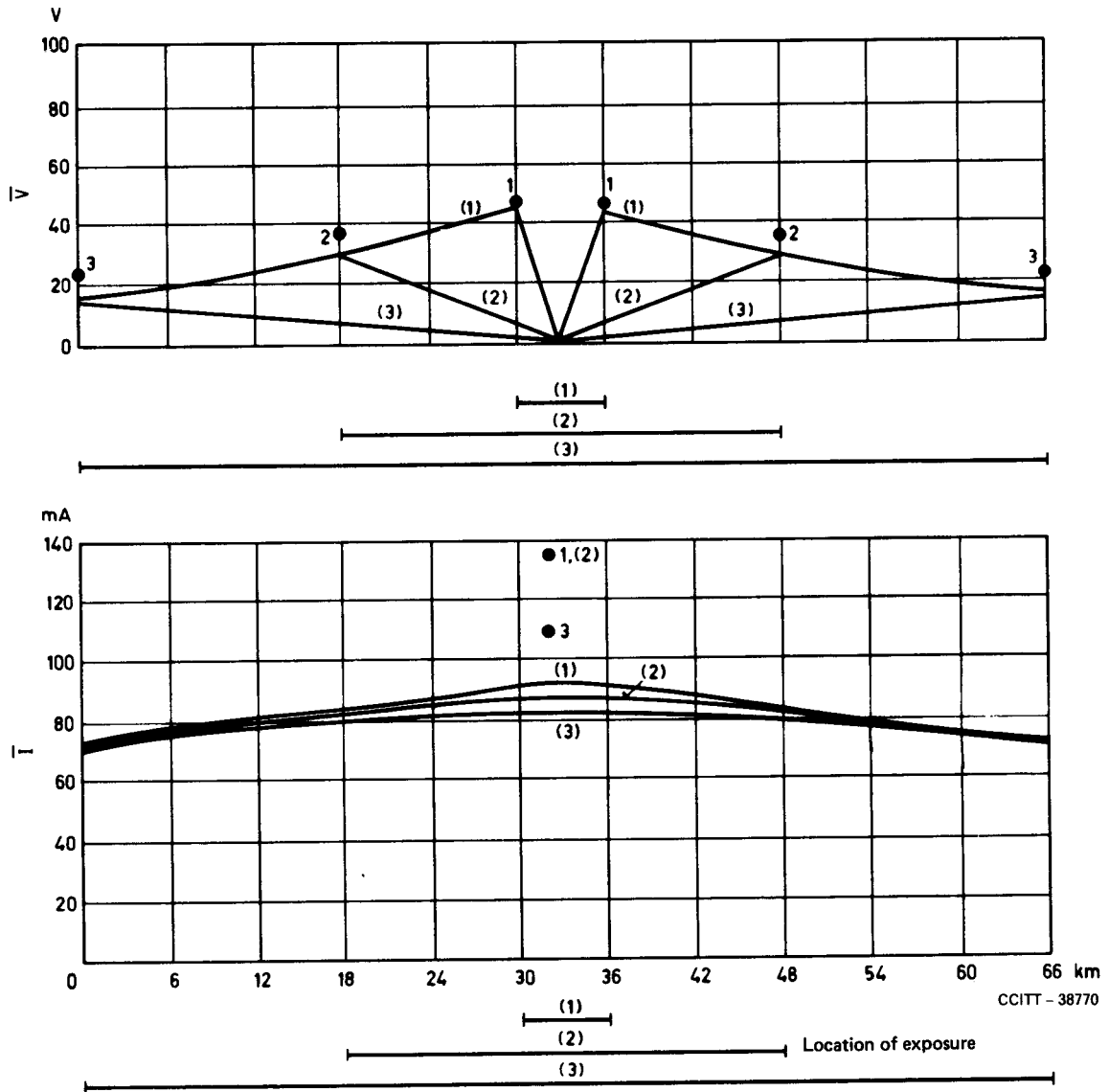

1, 2, 3 } Maxima determined by means
 ● of equivalent circuit

Length of exposure: 6 km, 30 km or 66 km
 Inducing voltage : 100 V

FIGURE C-4/K.16
 Voltages and currents for a 300-channel route with symmetrical exposures
 (outer conductor of coaxial pairs earthed)

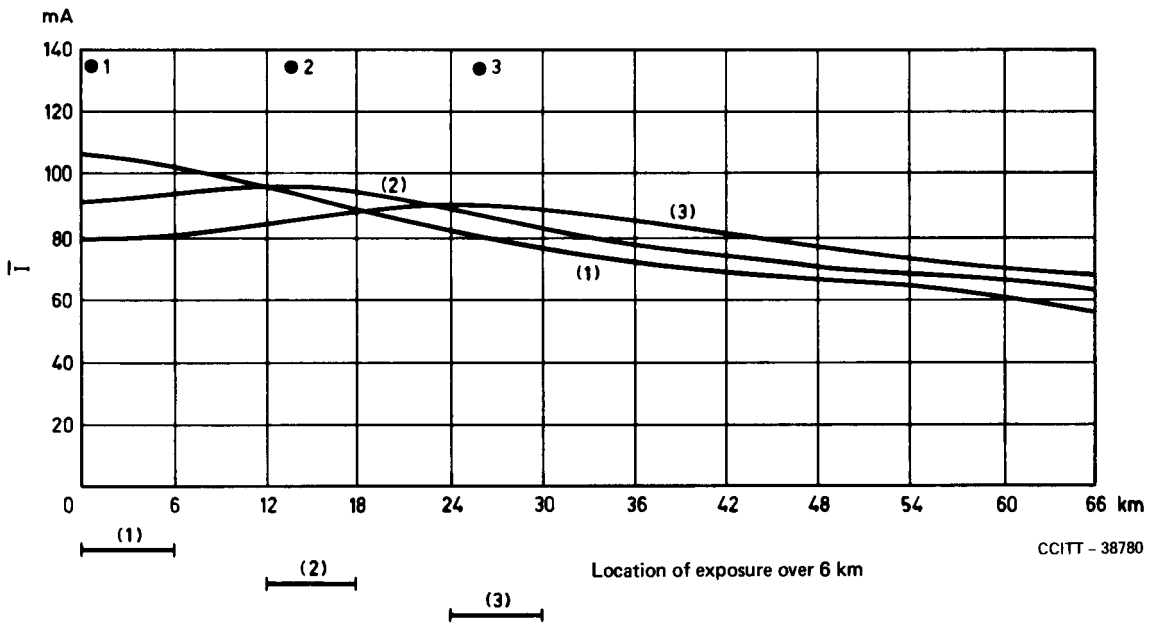
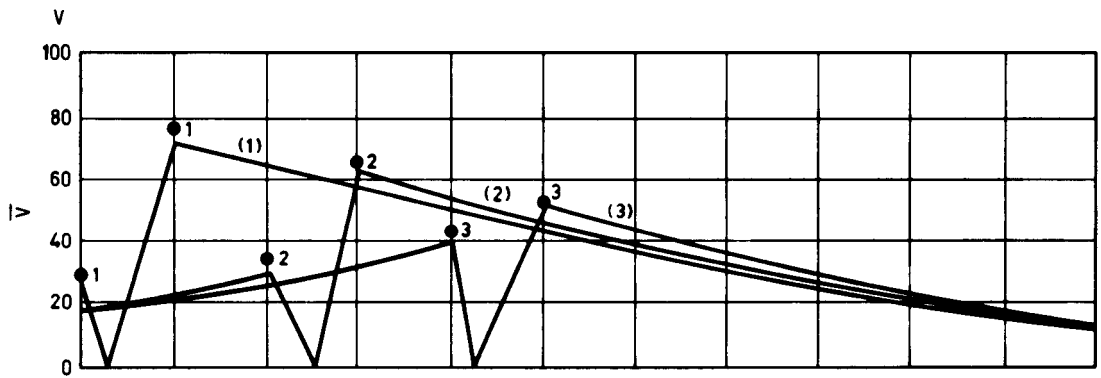

CCITT - 38780

1, 2, 3 } Maxima determined by means
 ● } of equivalent circuit

Length of exposure : 6 km
 Inducing voltage : 100 V

FIGURE C-5/K.16

Voltages and currents for a 300-channel route with asymmetrical exposures
 (outer conductor of coaxial pairs earthed)

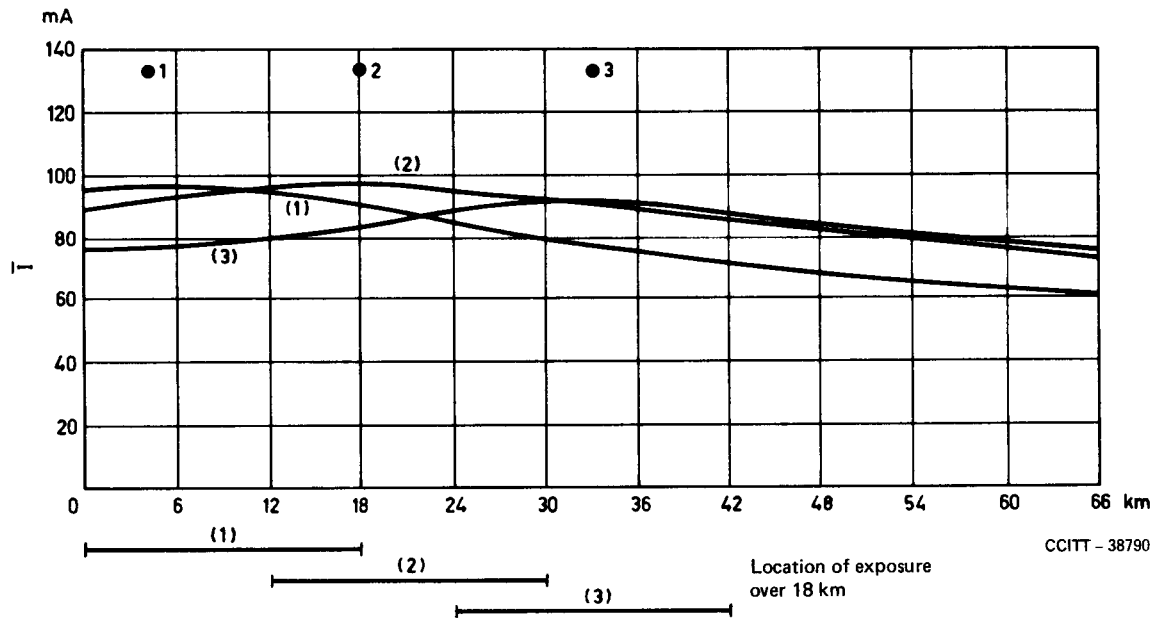
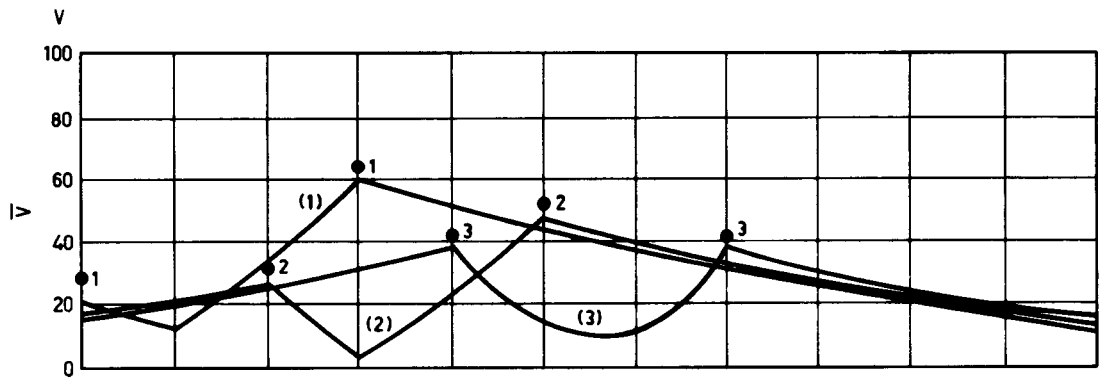

CCITT - 38790

1, 2, 3 } Maxima determined by means of
 ● } equivalent circuit

Length of exposure : 18 km
 Inducing voltage : 100 V

FIGURE C-6/K.16
 Voltages and currents for a 300-channel route with asymmetrical exposures
 (outer conductor of coaxial pairs earthed)

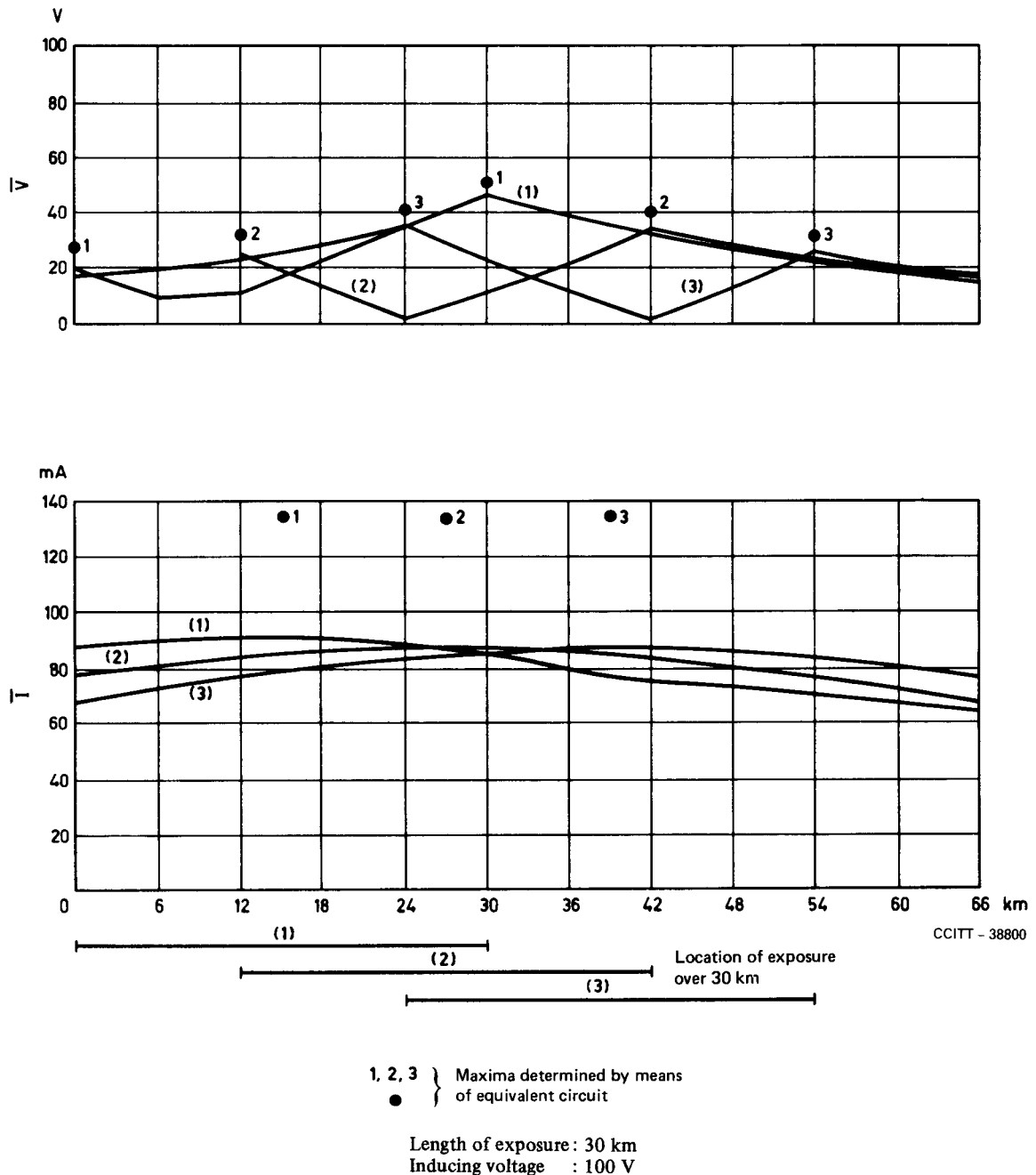

FIGURE C-7/K.16

Voltages and currents for a 300-channel route with asymmetrical exposures
(outer conductor of coaxial pairs earthed)

References

- [1] EMP (J.), SILCOOK (H.W.), STEWARD (C.J.): Power frequency induction on coaxial cables with application to transistorized systems, *Electrical Communication*, Vol. 40, No. 2, pp. 255-266, 1965.
- [2] ALZMANN (W.), VOGEL (W.): Berechnung der Starkstrombeeinflussung von Nachrichtenkabeln mit Koaxialpaaren und isolierten Aussenleitern (Calculation of power current interference in telecommunication cables with coaxial pairs and insulated outer conductors), *Signal und Draht* 57, No. 12, pp. 205-211, 1965.

Bibliography

- KEMP (J.): Estimating voltage surges on buried coaxial cables struck by lightning, *Electrical Communication*, Vol. 40, No. 3, pp. 381-385, 1965.
- POPP (E.): Lightning protection of line repeaters, *Conference Proceedings, ICC 68 of the IEEE*, pp. 169-174.