



INTERNATIONAL TELECOMMUNICATION UNION

**ITU-T**

TELECOMMUNICATION  
STANDARDIZATION SECTOR  
OF ITU

**I.363.5**

(08/96)

SERIES I: INTEGRATED SERVICES DIGITAL  
NETWORK

Overall network aspects and functions – Protocol layer  
requirements

---

**B-ISDN ATM Adaptation Layer specification:  
Type 5 AAL**

ITU-T Recommendation I.363.5

(Previously CCITT Recommendation)

---

ITU-T I-SERIES RECOMMENDATIONS  
**INTEGRATED SERVICES DIGITAL NETWORK**

GENERAL STRUCTURE	I.100–I.199
Terminology	I.110–I.119
Description of ISDNs	I.120–I.129
General modelling methods	I.130–I.139
Telecommunication network and service attributes	I.140–I.149
General description of asynchronous transfer mode	I.150–I.199
SERVICE CAPABILITIES	I.200–I.299
Scope	I.200–I.209
General aspects of services in ISDN	I.210–I.219
Common aspects of services in the ISDN	I.220–I.229
Bearer services supported by an ISDN	I.230–I.239
Teleservices supported by an ISDN	I.240–I.249
Supplementary services in ISDN	I.250–I.299
OVERALL NETWORK ASPECTS AND FUNCTIONS	I.300–I.399
Network functional principles	I.310–I.319
Reference models	I.320–I.329
Numbering, addressing and routing	I.330–I.339
Connection types	I.340–I.349
Performance objectives	I.350–I.359
<b>Protocol layer requirements</b>	<b>I.360–I.369</b>
General network requirements and functions	I.370–I.399
ISDN USER-NETWORK INTERFACES	I.400–I.499
Application of I-series Recommendations to ISDN user-network interfaces	I.420–I.429
Layer 1 Recommendations	I.430–I.439
Layer 2 Recommendations	I.440–I.449
Layer 3 Recommendations	I.450–I.459
Multiplexing, rate adaption and support of existing interfaces	I.460–I.469
Aspects of ISDN affecting terminal requirements	I.470–I.499
INTERNETWORK INTERFACES	I.500–I.599
MAINTENANCE PRINCIPLES	I.600–I.699
B-ISDN EQUIPMENT ASPECTS	I.700–I.799
ATM equipment	I.730–I.749
Management of ATM equipment	I.750–I.799

*For further details, please refer to ITU-T List of Recommendations.*

## **ITU-T RECOMMENDATION I.363.5**

### **B-ISDN ATM ADAPTATION LAYER SPECIFICATION: TYPE 5 AAL**

#### **Summary**

The ATM Adaptation Layer (AAL) type 5 enhances the service provided by the ATM layer to support functions required by the next higher layer. This AAL performs functions required by the user, control and management planes and supports the mapping between the ATM layer and the next higher layer.

The AAL type 5 supports the non-assured transfer of user data frames. The data sequence integrity is maintained and transmission errors are detected. The AAL type 5 is characterized by transmitting in every ATM cell (but the last) of a PDU 48 octets of user data, i.e., in most of the cells there is no overhead encountered.

In a new Annex E, the corrupted data delivery option is specified.

#### **Source**

ITU-T Recommendation I.363 was prepared by the ITU-T Study Group XVIII (1988-1993) and was approved by the WTSC (Helsinki, March 1-12, 1993). The current revision which lead to different ITU-T Recommendations (e.g., ITU-T Recommendation I.363.5 for the AAL type 5) for the different AAL types was prepared and approved by the ITU-T Study Group 13 (1993-1996) on the 27th of August 1996.

#### **Keywords**

ATM Adaptation Layer (AAL), Asynchronous Transfer Mode (ATM), Broadband Integrated Services Digital Network (B-ISDN)

## FOREWORD

ITU (International Telecommunication Union) is the United Nations Specialized Agency in the field of telecommunications. The ITU Telecommunication Standardization Sector (ITU-T) is a permanent organ of the ITU. The ITU-T is responsible for studying technical, operating and tariff questions and issuing Recommendations on them with a view to standardizing telecommunications on a worldwide basis.

The World Telecommunication Standardization Conference (WTSC), which meets every four years, establishes the topics for study by the ITU-T Study Groups which, in their turn, produce Recommendations on these topics.

The approval of Recommendations by the Members of the ITU-T is covered by the procedure laid down in WTSC Resolution No. 1.

In some areas of information technology which fall within ITU-T's purview, the necessary standards are prepared on a collaborative basis with ISO and IEC.

## NOTE

In this Recommendation, the expression "Administration" is used for conciseness to indicate both a telecommunication administration and a recognized operating agency.

## INTELLECTUAL PROPERTY RIGHTS

The ITU draws attention to the possibility that the practice or implementation of this Recommendation may involve the use of a claimed Intellectual Property Right. The ITU takes no position concerning the evidence, validity or applicability of claimed Intellectual Property Rights, whether asserted by ITU members or others outside of the Recommendation development process.

As of the date of approval of this Recommendation, the ITU had/had not received notice of intellectual property, protected by patents, which may be required to implement this Recommendation. However, implementors are cautioned that this may not represent the latest information and are therefore strongly urged to consult the TSB patent database.

© ITU 1997

All rights reserved. No part of this publication may be reproduced or utilized in any form or by any means, electronic or mechanical, including photocopying and microfilm, without permission in writing from the ITU.

## CONTENTS

	<b>Page</b>
1 Scope.....	1
2 Normative references .....	1
3 Definitions .....	1
4 Abbreviations.....	1
5 Conventions .....	2
6 Framework of AAL type 5.....	3
7 Service provided by the Common Part of the AAL type 5.....	5
7.1 Primitives for the AAL type 5.....	6
7.2 Primitives for the CPCS of the AAL type 5.....	6
7.2.1 Primitives for the data transfer service .....	6
7.2.2 Primitives for the abort service.....	7
7.3 Primitives for the SAR sublayer of the AAL type 5.....	8
7.3.1 Primitives for the data transfer service .....	8
8 Interaction with the management and control plane.....	8
8.1 Management plane.....	8
8.2 Control plane.....	8
9 Functions, structure and coding of the AAL type 5.....	9
9.1 Segmentation and Reassembly (SAR) sublayer.....	9
9.1.1 Functions of the SAR sublayer .....	9
9.1.2 SAR-PDU structure and coding.....	9
9.2 Convergence Sublayer (CS).....	9
9.2.1 Functions, structure and coding for the CPCS.....	9
10 Procedures.....	13
10.1 Procedures for the SAR sublayer.....	13
10.1.1 State variables of the SAR sublayer at the sender side.....	13
10.1.2 Procedures of the SAR sublayer at the sender side .....	13
10.1.3 State variables for the SAR sublayer at the receiver side.....	13
10.1.4 Procedures of the SAR sublayer at the receiver side.....	13
10.2 Procedures of the CPCS for the Message Mode service.....	13
10.2.1 State variables of the CPCS at the sender side .....	13
10.2.2 Procedures of the CPCS at the sender side.....	14
10.2.3 State variables of the CPCS at the receiver side.....	14
10.2.4 Procedures of the CPCS at the receiver side .....	14

	<b>Page</b>
10.3 Procedures for the CPCS for the Streaming Mode service.....	15
10.4 Summary of parameters and values for an AAL type 5 connection .....	15
Annex A – Details of the data unit naming convention.....	16
Annex B – General framework of the AAL type 5.....	18
B.1 Message segmentation and reassembly.....	18
B.2 PDU headers, trailers and terminology.....	18
B.3 Examples of the segmentation and reassembly process.....	18
Annex C – Functional model for the AAL type 5.....	21
Annex D – SDL diagram for the SAR and the CPCS of the AAL type 5.....	22
D.1 SDL for the SAR sublayer .....	22
D.1.1 The SAR sender.....	22
D.1.2 The SAR receiver .....	23
D.2 SDL for the Common Part CS (CPCS) procedures .....	23
D.2.1 The CPCS sender.....	23
D.2.2 The CPCS receiver .....	23
Annex E – Corrupted data delivery option.....	29
E.1 Service provided by corrupted data delivery option.....	29
E.2 Parameter definitions .....	29
E.3 Procedures to provide corrupted data delivery for the message mode service.....	30
E.4 Procedures to provide corrupted data delivery for the streaming mode service.....	32
E.5 SDL representation of procedures to provide corrupted data delivery .....	32
Appendix I – Example CPCS-PDUs for the AAL type 5 .....	39
Appendix II – Insight into service provided by the procedures of Annex E.....	40

## Recommendation I.363.5

### B-ISDN ATM ADAPTATION LAYER SPECIFICATION: TYPE 5 AAL

(Geneva, 1996)

#### 1 Scope

This Recommendation describes the AAL type 5, the interactions between the AAL type 5 Common Part and the next higher layer, the AAL type 5 Common Part and the ATM layer, as well as the AAL type 5 Common Part peer-to-peer operations.

This Recommendation is applicable to equipment to be attached to a B-ISDN User Network Interface (UNI) or B-ISDN Network Node Interface (NNI) when the services of the AAL type 5 are to be supported.

#### 2 Normative references

The following ITU-T Recommendations and other references contain provision which, through reference in this text, constitute provisions of this Recommendation. At the time of publication, the editions indicated were valid. All Recommendations and other references are subject to revision; all users of this Recommendation are therefore encouraged to investigate the possibility of applying the most recent edition of the Recommendations and other references listed below. A list of the currently valid ITU-T Recommendations is regularly published.

- [1] ITU-T Recommendation I.361 (1995), *B-ISDN ATM layer specification*.
- [2] ITU-T Recommendation X.200 (1994), *Information technology – Open Systems Interconnection – Basic reference model: The Basic Model*.
- [3] ITU-T Recommendation X.210 (1993), *Information technology – Open Systems Interconnection – Basic reference model: Conventions for the definition of OSI services*.

#### 3 Definitions

This Recommendation is based upon the concepts developed in Recommendations X.200 [2] and X.210 [3]. Details of the data unit naming convention used in this Recommendation can be found in Annex A.

#### 4 Abbreviations

This Recommendation uses the following abbreviations:

AAL	ATM Adaptation Layer
AAL-SAP	AAL Service Access Point
AAL-SDU	AAL Service Data Unit
ATM	Asynchronous Transfer Mode
ATM-SDU	ATM Service Data Unit
AUU	ATM User-to-ATM-User Indication
CPCS	Common Part Convergence Sublayer

CPCS-CI	CPCS Congestion Indication
CPCS-IDU	CPCS Interface Data Unit
CPCS-LP	CPCS Loss Priority
CPCS-PDU	CPCS Protocol Data Unit
CPCS-SDU	CPCS Service Data Unit
CPCS-UU	CPCS User-to-User Indication
CPI	Common Part Indicator
CRC	Cyclic Redundancy Check
CS	Convergence Sublayer
ID	Interface Data
Length	Length of CPCS-PDU Payload
LSB	Least Significant Bit
M	More
MM	Message Mode
MSB	Most Significant Bit
NNI	Network Node Interface
PAD	Padding
QOS	Quality of Service
RS	Reception Status
SAR	Segmentation and Reassembly (Sublayer)
SAR-CI	SAR Congestion Indication
SAR-LP	SAR Loss Priority
SAR-PDU	SAR Protocol Data Unit
SAR-SDU	SAR Service Data Unit
SM	Streaming Mode
SSCS	Service Specific Convergence Sublayer
SSCS-PDU	SSCS Protocol Data Unit
UNI	User Network Interface

## 5 Conventions

The AAL type 5 receives from the ATM layer the information in the form of a 48-octet ATM Service Data Unit (ATM-SDU). The AAL passes to the ATM layer information in the form of a 48-octet ATM-SDU. The primitives between the ATM layer and the AAL type 5 are defined in Recommendation I.361 [1].



## 6 Framework of AAL type 5

The Convergence Sublayer (CS) has been subdivided into the Common Part CS (CPCS) and the Service Specific CS (SSCS) as shown in Figure 1. The CPCS and the SAR sublayer are called the "Common Part of the AAL type 5". Further clarification can be found in Annex B.

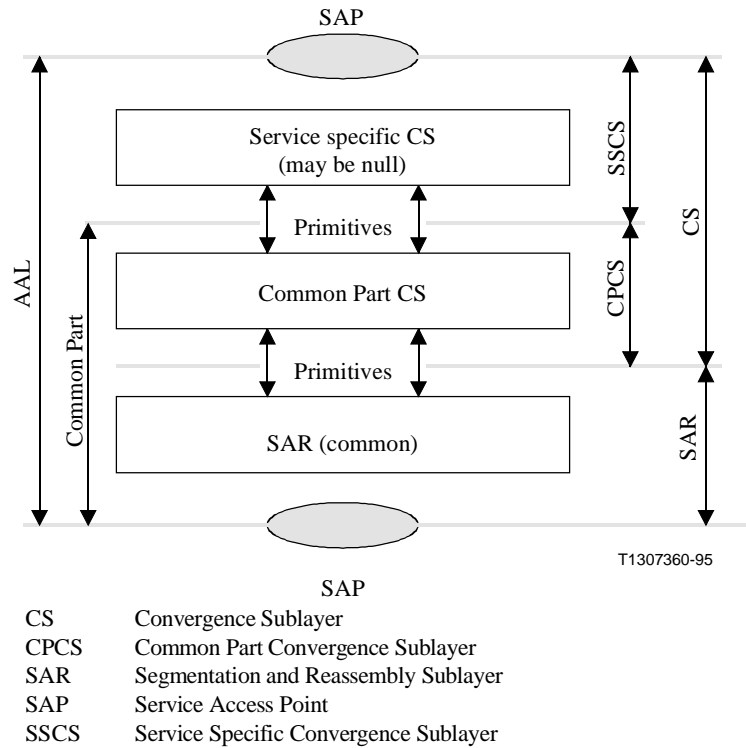
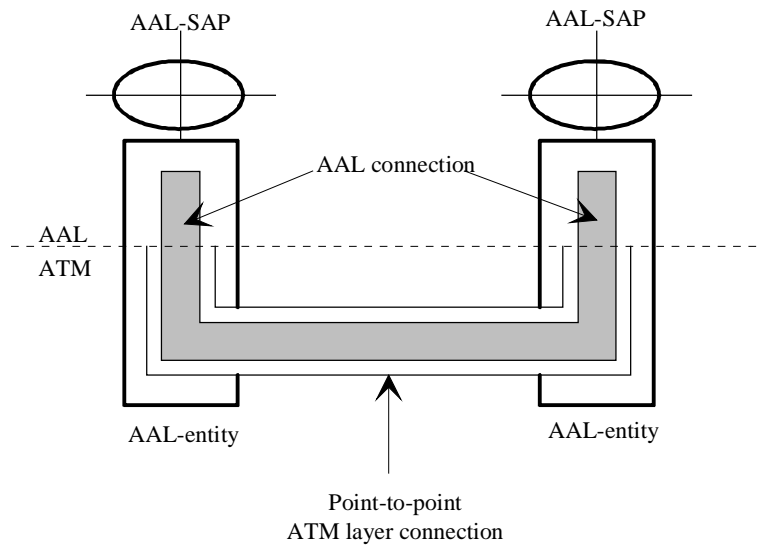

**Figure 1/I.363.5 – Structure of the AAL type 5**

Different SSCS protocols, to support specific AAL user services, or groups of services, may be defined. The SSCS may also be null, in the sense that it only provides for the mapping of the equivalent primitives of the AAL to those of the CPCS and vice versa. SSCS protocols are specified in separate Recommendations.

The AAL type 5 provides the capabilities to transfer the AAL-SDU from one AAL-SAP to one other AAL-SAP through the ATM network [see Figure 2 a)]. The AAL users will have the capability to select a given AAL-SAP associated with the QOS required to transport that AAL-SDU (for example, delay and loss sensitive QOS).

The AAL type 5 in non-assured operation provides the capability to transfer the AAL-SDUs from one AAL-SAP to more than one AAL-SAP through the ATM network [see Figure 2 b)].



**a) Point-to-point AAL connection**

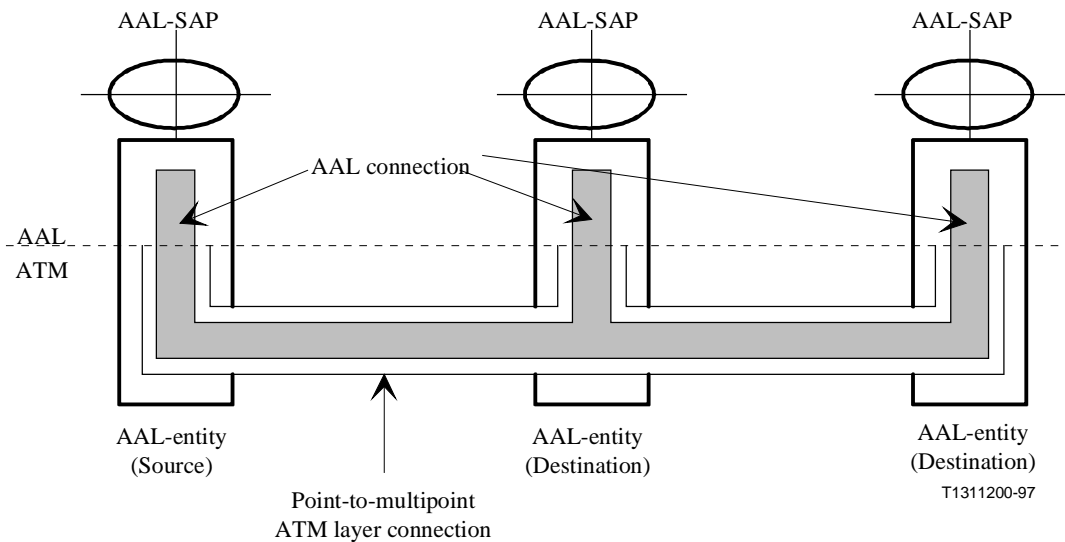

**b) Point-to-multipoint AAL connection**

**Figure 2/I.363.5**

The AAL type 5 makes use of the service provided by the underlying ATM layer (see Figure 3). Multiple AAL connections may be associated with a single ATM layer connection, allowing multiplexing at the AAL; however, if multiplexing is used in the AAL type 5, it occurs in the SSCS. The AAL user selects the QOS provided by the AAL through the choice of the AAL-SAP used for data transfer.

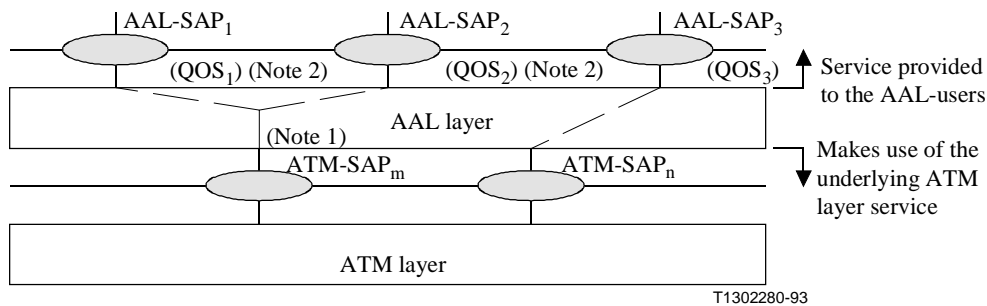

NOTE 1 – If multiplexing is present at the AAL, it occurs in the SSCS

NOTE 2 – How QOS at the AAL-SAP is mapped to the ATM-SAP QOS in the event of multiplexing in the AAL is for further study.

**Figure 3/I.363.5 – Relation between AAL-SAP and ATM-SAP**

## 7 Service provided by the Common Part of the AAL type 5

The Common Part of the AAL type 5 provides the capabilities to transfer the CPCS-SDU from one CPCS user to one other CPCS user, or, when the AAL type 5 is operated in the non-assured mode, to one or more other CPCS users through the ATM network.

Two modes of service are defined: message and streaming.

- i) *Message Mode service* – The CPCS-SDU is passed across the CPCS interface in exactly one CPCS-IDU. This service provides the transport of a single CPCS-SDU in one CPCS-PDU.
- ii) *Streaming Mode service* – The CPCS-SDU is passed across the CPCS interface in one or more CPCS-IDUs. The transfer of these CPCS-IDUs across the CPCS interface may occur separated in time. This service provides the transport of all the CPCS-IDUs belonging to a single CPCS-SDU into one CPCS-PDU. An internal pipelining function in the CPCS may be applied which provides the means by which the sending CPCS entity initiates the transfer to the receiving CPCS entity before it has the complete CPCS-SDU available. The Streaming Mode service includes an abort service by which the discarding of a CPCS-SDU partially transferred across the interface can be requested.

Both modes of service may offer the non-assured operation peer-to-peer operational procedures:

- Integral CPCS-SDU may be delivered, lost, or corrupted.
- Lost and corrupted CPCS-SDUs will not be corrected by retransmission. An optional feature may be provided to allow corrupted CPCS-SDUs to be delivered to the user. (The corrupted data delivery option is specified in Annex E.)
- Flow control may be provided as an option; however, this option is for further study.

NOTE – If assured operations are required, they must be provided by the SSCS or by higher layers.

The CPCS has the following service characteristics:

- Non-assured data transfer of user data frames with any length measured in octets from 1 to 65 535 octets.
- The CPCS connection will be established by management or by the control plane.
- Error detection and optional indication (bit error and cell loss or gain).
- CPCS-SDU sequence integrity on each CPCS connection.

The functional model for AAL type 5 as contained in Annex C shows the interrelation between the SAR, CPCS and SSCS and the SAR and CPCS primitives.

## 7.1 Primitives for the AAL type 5

These primitives are service specific and are contained in separate Recommendations on SSCS protocols.

The SSCS may be null, in the sense that it only provides for the mapping of the equivalent primitives of the AAL to CPCS and vice versa. In this case, the primitives for the AAL are equivalent to those for the CPCS (see 7.2) but identified as AAL-UNITDATA request, AAL-UNITDATA indication, AAL-U-ABORT request, AAL-U-ABORT indication and AAL-P-ABORT indication, consistent with the primitive naming convention at an SAP.

## 7.2 Primitives for the CPCS of the AAL type 5

As there exists no Service Access Point (SAP) between the sublayers of the AAL type 5, the primitives are called "invoke" and "signal" instead of the conventional "request" and "indication" to highlight the absence of the SAP.

### 7.2.1 Primitives for the data transfer service

These primitives are CPCS-UNITDATA invoke and the CPCS-UNITDATA signal. They are used for the data transfer. The following parameters are defined:

- *Interface Data (ID)*

This parameter specifies the interface data unit exchanged between the CPCS and the SSCS entity. The interface data is an integral multiple of one octet. If the CPCS entity is operating in the Message Mode service, the Interface Data represents a complete CPCS-SDU; when operating in the Streaming Mode service, the Interface Data does not necessarily represent a complete CPCS-SDU.
- *More (M)*

In the Message Mode service, this parameter is not used. In the Streaming Mode service, this parameter specifies whether the Interface Data communicated contains a beginning/continuation of a CPCS-SDU or the end of/complete CPCS-SDU.
- *CPCS-Loss Priority (CPCS-LP)*

This parameter indicates the loss priority for the associated CPCS-SDU. It can take only two values, one for high priority and the other for low priority. In Streaming Mode, this parameter is mandatory with the first invoke primitive related to a certain CPCS-SDU; otherwise, it is not present. At the receiving side, this parameter is only present with the last signal primitive related to a certain CPCS-SDU. This parameter is mapped to and from the SAR-LP parameter. In general, this parameter has no end-to-end significance.
- *CPCS Congestion Indication (CPCS-CI)*

This parameter indicates whether the associated CPCS-SDU has experienced congestion. In Streaming Mode, this parameter is mandatory with the first invoke primitive related to a certain CPCS-SDU; otherwise, it is not present. At the receiving side, this parameter is only present with the last signal primitive related to a certain CPCS-SDU. This parameter is mapped to and from the SAR-CI parameter.

- *CPCS User-to-User indication (CPCS-UU)*  
This parameter is transparently transported by the CPCS between peer CPCS users. In Streaming Mode, this parameter is mandatory with the last invoke primitive related to a certain CPCS-SDU; otherwise, it is not present. At the receiving side, this parameter is only present with the last signal primitive related to a certain CPCS-SDU.
- *Reception Status (RS)*  
This parameter indicates that the associated CPCS-SDU delivered may be corrupted. This parameter is only utilized if the corrupted data delivery option is used (see Annex E). In Streaming Mode, this parameter is only present with the last signal primitive related to a certain CPCS-SDU.

Depending on the service mode (Message or Streaming Mode service, discarding or delivery of corrupted data), not all parameters are required. This is summarized in Table 1.

**Table 1/I.363.5 – Parameters of the CPCS-UNITDATA**

Parameter	Type	MM	SM	Comments
Interface Data (ID)	Invoke Signal	m m	m m	Whole or partial CPCS-SDU
More (M)	Invoke Signal	– –	m m	M = 0: End of CPCS-SDU M = 1: Not end of CPCS-SDU
CPCS – Loss Priority (CPCS-LP)	Invoke Signal	m m	m <sup>1</sup> m <sup>2</sup>	Mapped to and from the ATM layer's CLP field CPCS-LP = 1: Low Priority CPCS-LP = 0: High Priority
CPCS – Congestion Indication (CPCS-CI)	Invoke Signal	m m	m <sup>1</sup> m <sup>2</sup>	Mapped to and from the ATM layer's congestion indication parameter CPCS-CI = 1: Congestion experienced CPCS-CI = 0: No congestion experienced
CPCS – User-to-User Indication (CPCS-UU)	Invoke Signal	m m	m <sup>2</sup> m <sup>2</sup>	Transparently transported by the CPCS
Reception status (RS) (Note)	Invoke Signal	– m	– m <sup>2</sup>	Indication of corrupted data
MM Message Mode service SM Streaming Mode service m Mandatory m <sup>1</sup> Mandatory with the first invoke primitive related to a certain CPCS-SDU, otherwise absent m <sup>2</sup> Mandatory with the last invoke or signal primitive related to a certain CPCS-SDU, otherwise absent – Not present NOTE – Not present if the corrupted data delivery option is not supported.				

### 7.2.2 Primitives for the abort service

These primitives are used in the Streaming Mode service.

a) *CPCS-U-ABORT invoke and CPCS-U-ABORT signal*

These primitives are used by the sending CPCS user to invoke the abort service and to signal to the receiving CPCS user that a partially delivered CPCS-SDU is to be discarded by instruction from its peer entity. No parameters are defined.

This primitive is not used in Message Mode.

b) *CPCS-P-ABORT signal*

This primitive is used by the CPCS entity to signal to its user that a partially delivered CPCS-SDU is to be discarded due to the occurrence of some error in the CPCS or below. No parameters are defined.

This primitive is not used in Message Mode.

### **7.3 Primitives for the SAR sublayer of the AAL type 5**

These primitives model the exchange of information between the SAR sublayer and the CPCS.

As there exists no Service Access Point (SAP) between the sublayers of the AAL type 5, the primitives are called "invoke" and "signal" instead of the conventional "request" and "indication" to highlight the absence of the SAP.

#### **7.3.1 Primitives for the data transfer service**

These primitives are SAR-UNITDATA invoke and the SAR-UNITDATA signal. They are used for the data transfer. The following parameters are defined:

– *Interface Data (ID)*

This parameter specifies the Interface Data unit exchanged between the SAR and the CPCS entity. The Interface Data is an integral multiple of 48 octets. The Interface Data does not necessarily represent a complete SAR-SDU.

– *More (M)*

This parameter specifies whether the Interface Data communicated contains the end of the SAR-SDU.

– *SAR-Loss Priority (SAR-LP)*

This parameter indicates the loss priority for the associated SAR Interface Data. It can take only two values, one for high priority, and the other for low priority. This parameter is mapped to the ATM layer's Submitted Loss Priority parameter and from the ATM layer's Received Loss Priority parameter.

– *SAR-Congestion Indication (SAR-CI)*

This parameter indicates whether the associated SAR Interface Data has experienced congestion. This parameter is mapped to and from the ATM layer's Congestion Indication parameter.

## **8 Interaction with the management and control plane**

### **8.1 Management plane**

For further study.

### **8.2 Control plane**

There are no interactions between the U-plane and the C-plane in the CPCS and the SAR sublayers. There may be interactions in the SSCS; however, if they exist, they are specified in separate Recommendations on SSCS protocols.

## 9 Functions, structure and coding of the AAL type 5

### 9.1 Segmentation and Reassembly (SAR) sublayer

#### 9.1.1 Functions of the SAR sublayer

The SAR sublayer functions are performed on an SAR-PDU basis. The SAR sublayer accepts variable length SAR-SDUs which are integral multiples of 48 octets from the CPCS and generates SAR-PDUs containing 48 octets of SAR-SDU data.

a) *Preservation of SAR-SDU*

This function preserves the SAR-SDU by providing for an "end of SAR-SDU" indication.

b) *Handling of congestion information*

This function provides for the passing of congestion information between the layers above the SAR sublayer and the one below in both directions.

c) *Handling of loss priority information*

This function provides for the passing of cell loss priority information between the layers above the SAR sublayer and the one below in both directions.

#### 9.1.2 SAR-PDU structure and coding

The SAR sublayer utilizes the ATM-User-to-ATM-User indication (AUU) parameter of the ATM layer primitives (the relationship between the AUU parameter and the ATM layer PTI encoding is defined in 2.2.4/I.361) to indicate that an SAR-PDU contains the end of a SAR-SDU. An SAR-PDU where the value of the AUU parameter is "1" indicates the end of an SAR-SDU; the value of "0" indicates the beginning or continuation of an SAR-SDU. The structure of the SAR-PDU is illustrated in Figure 4.

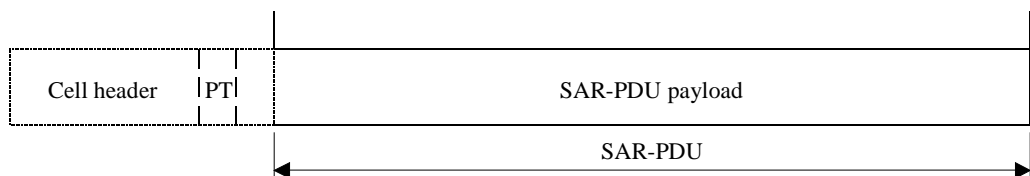

T1300090-93

PT Payload Type

NOTE – The Payload Type field belongs to the ATM header. It conveys the value of the AUU parameter end-to-end.

**Figure 4/I.363.5 – SAR-PDU format for the AAL type 5**

### 9.2 Convergence Sublayer (CS)

#### 9.2.1 Functions, structure and coding for the CPCS

For the service characteristics, see clause 7.

##### 9.2.1.1 Functions of the CPCS

The CPCS functions are performed per CPCS-PDU. The CPCS provides several functions in support of the CPCS service user. The functions provided depend on whether the CPCS service user is operating in Message or Streaming Mode.

- i) *Message Mode service* – The CPCS-SDU is passed across the CPCS interface in exactly one CPCS-IDU. This service provides the transport of a single CPCS-SDU in one CPCS-PDU.
- ii) *Streaming Mode service* – The CPCS-SDU is passed across the CPCS interface in one or more CPCS-IDUs. The transfer of these CPCS-IDUs across the CPCS interface may occur separated in time. This service provides the transport of all the CPCS-IDUs belonging to a single CPCS-SDU into one CPCS-PDU. An internal pipelining function in the CPCS may be applied which provides the means by which the sending CPCS entity initiates the transfer to the receiving CPCS entity before it has the complete CPCS-SDU available. The Streaming Mode service includes an abort service by which the discarding of a CPCS-SDU partially transferred across the interface can be requested.

NOTE – At the sending side, parts of the CPCS-PDU may have to be buffered if the restriction ("Interface Data are a multiple of 48 octets", see 9.1.1) cannot be satisfied.

The functions implemented by the CPCS include:

- a) *Preservation of CPCS-SDU*  
This function provides for the delineation and transparency of CPCS-SDUs.
- b) *Preservation of CPCS user-to-user information*  
This function provides for the transparent transfer of CPCS user-to-user information.
- c) *Error detection and handling*  
This function provides for the detection and handling of CPCS-PDU corruption. Corrupted CPCS-SDUs are either discarded or are optionally delivered to the SSCS. The procedures for delivery of corrupted CPCS-SDUs are defined in Annex E. When delivering corrupted data to the CPCS user, an error indication is associated with the delivery.  
Examples of detected errors would include: received length and CPCS-PDU Length field mismatch including buffer overflow, and improperly formatted CPCS-PDU and CPCS-CRC errors.
- d) *Abort*  
This function provides for the means to abort a partially transmitted CPCS-SDU. This function is indicated in the Length field.
- e) *Padding*  
A padding function provides for 48-octet alignment of the CPCS-PDU trailer.
- f) *Handling of congestion information*  
This function provides for the passing of congestion information between the layers above the CPCS and the one below in both directions.
- g) *Handling of loss priority information*  
This function provides for the passing of cell loss priority information between the layers above the CPCS and the one below in both directions.

Other functions are for further study.

### 9.2.1.2 CPCS-PDU structure and coding

The CPCS functions require an 8-octet CPCS-PDU trailer. The CPCS-PDU trailer is always located in the last 8 octets of the last SAR-PDU of the CPCS-PDU. Therefore, a padding field provides for a 48-octet alignment of the CPCS-PDU. The CPCS-PDU trailer together with the padding field and the CPCS-PDU payload comprise the CPCS-PDU. The sizes and positions of fields for the CPCS-PDU structure are given in Figure 5.



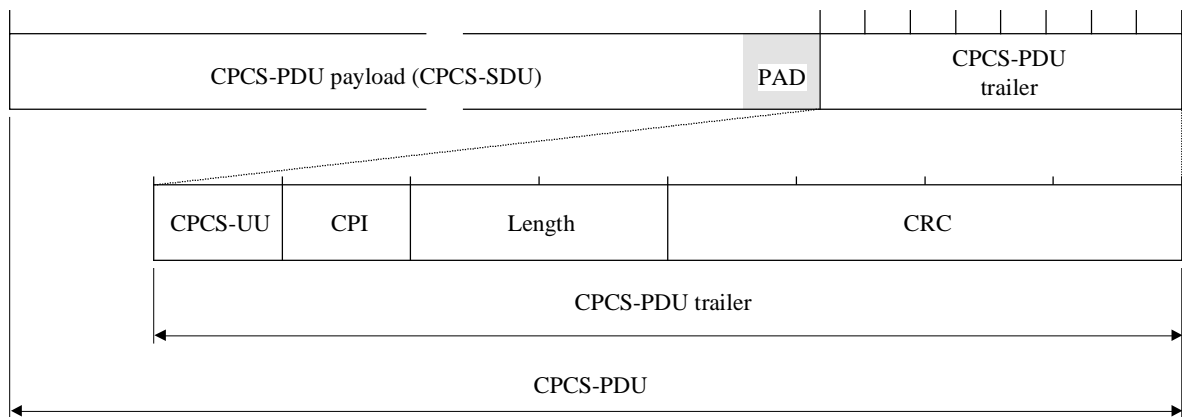

T1300100-93

PAD	Padding	(0 ... 47 octets)
CPCS-UU	CPCS User-to-User Indication	(1 octet)
CPI	Common Part Indicator	(1 octet)
Length	Length of CPCS-SDU	(2 octets)
CRC	Cyclic Redundancy Check	(4 octets)

**Figure 5/I.363.5 – CPCS-PDU Format for the AAL type 5**

The coding of the CPCS-PDU conforms to the coding conventions specified in 2.1/I.361.

a) *CPCS-PDU payload*

The CPCS-PDU payload is used to carry the CPCS-SDU. This field is octet aligned and can range from 1 to 65 535 octets in length.

b) *Padding (PAD) field*

Between the end of the CPCS-PDU payload and the CPCS-PDU trailer, there will be from 0 to 47 unused octets. These unused octets are called the Padding (PAD) field; they are strictly used as filler octets and do not convey any information. Any coding is acceptable. This padding field complements the CPCS-PDU (including CPCS-PDU payload, padding field, and CPCS-PDU trailer) to an integral multiple of 48 octets.

The function of the PAD field is shown in Figure 6.

c) *CPCS User-to-User indication (CPCS-UU) field*

The CPCS-UU field is used to transparently transfer CPCS user-to-user information.

d) *Common Part Indicator (CPI) field*

One of the functions of the CPI field is to align the CPCS-PDU trailer to 64 bits. Other functions are for further study. Possible additional functions may include identification of layer management messages. When only the 64-bit alignment function is used, this field shall be coded as zero. Other codings are for further study.

e) *Length field*

The Length field is used to encode the length of the CPCS-PDU payload field. The Length field value is also used by the receiver to detect the loss or gain of information.

The length is binary encoded as number of octets.

A Length field coded as zero is used for the abort function.

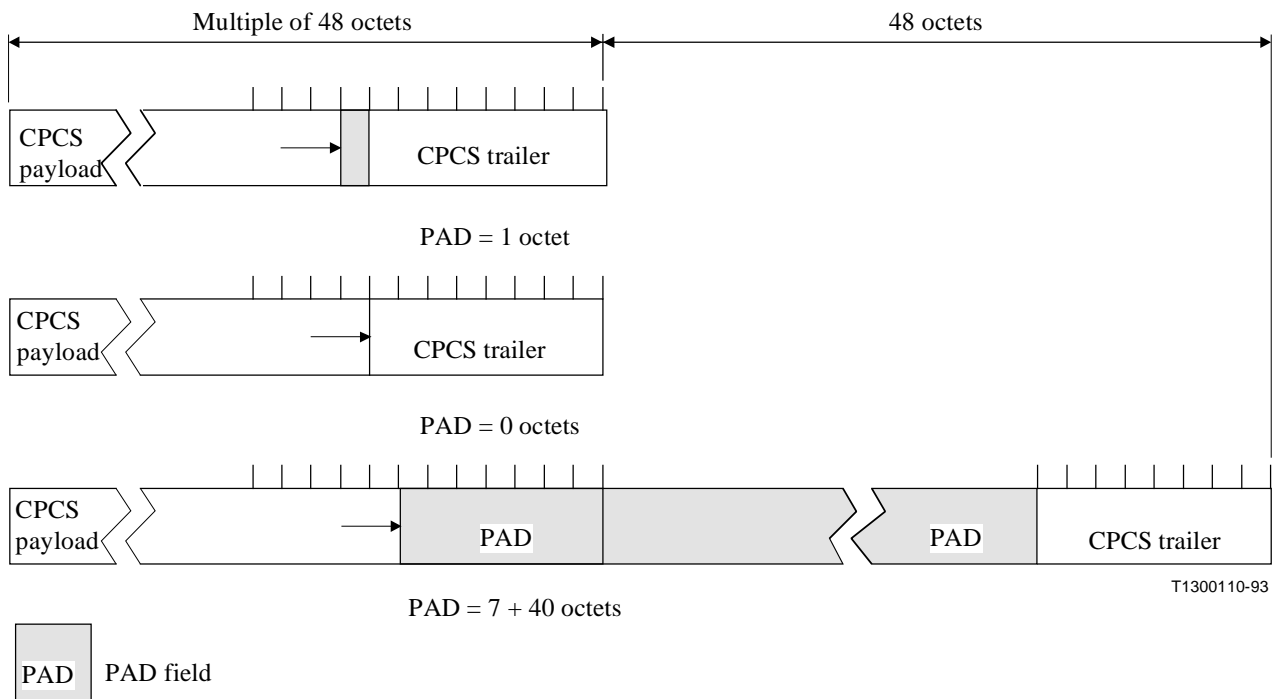

**Figure 6/I.363.5 – Examples of the PAD field function**

f) *CRC field*

The CRC-32 is used to detect bit errors in the CPCS-PDU.

The CRC field is filled with the value of a CRC calculation which is performed over the entire contents of the CPCS-PDU, including the CPCS-PDU payload, the PAD field, and the first four octets of the CPCS-PDU trailer. The CRC field shall contain the ones complement of the sum (modulo 2) of:

- 1) the remainder of  $x^k (x^{31} + x^{30} + \dots + x + 1)$  divided (modulo 2) by the generator polynomial, where  $k$  is the number of bits of the information over which the CRC is calculated; and
- 2) the remainder of the division (modulo 2) by the generator polynomial of the product of  $x^{32}$  by the information over which the CRC is calculated.

The CRC-32 generator polynomial is:

$$G(x) = x^{32} + x^{26} + x^{23} + x^{22} + x^{16} + x^{12} + x^{11} + x^{10} + x^8 + x^7 + x^5 + x^4 + x^2 + x + 1$$

The result of the CRC calculation is placed with the least significant bit right justified in the CRC field.

As a typical implementation at the transmitter, the initial content of the register of the device computing the remainder of the division is preset to all "1"s and is then modified by division by the generator polynomial (as described above) on the information over which the CRC is to be calculated; the ones complement of the resulting remainder is put into the CRC field.

As a typical implementation at the receiver, the initial content of the register of the device computing the remainder of the division is preset to all "1"s. The final remainder, after multiplication by  $x^{32}$  and then division (modulo 2) by the generator polynomial of the serial incoming CPCS-PDU, will be (in the absence of errors):

$$C(x) = x^{31} + x^{30} + x^{26} + x^{25} + x^{24} + x^{18} + x^{15} + x^{14} + x^{12} + x^{11} + x^{10} + x^8 + x^6 + x^5 + x^4 + x^3 + x + 1$$

An example of the CRC calculation is given in Appendix I.

## **10 Procedures**

The SDL diagrams of the procedures are given in Annex D. If there exists any difference between the prose description in this clause and the SDL diagrams in Annex D, the SDL diagrams take precedence.

NOTE – Implementations may or may not make the boundary between the CPCS and the SAR sublayer visible and accessible.

### **10.1 Procedures for the SAR sublayer**

The structure and coding of the SAR-PDU is defined in 9.1.2.

#### **10.1.1 State variables of the SAR sublayer at the sender side**

The SAR sender maintains no state variables.

#### **10.1.2 Procedures of the SAR sublayer at the sender side**

- 1) Upon receiving a SAR-UNITDATA invoke primitive from the CPCS, the SAR sender shall start the segmenting process. If the interface data has a length of more than 48 octets, the SAR sender will generate more than one SAR-PDU. In all SAR-PDUs, the SAR-PDU payload field shall be filled with 48 octets of CPCS-PDU information.
- 2) If the More parameter in the SAR-UNITDATA invoke primitive has the value "0", the SAR sender shall set the AUU parameter in the ATM-DATA request primitive for the last SAR-PDU generated from the interface data to "1"; in all other cases (i.e. the More parameter has the value "1" or the ATM-DATA-request primitive does not contain the last data generated from the interface data), it shall set the AUU parameter to "0".
- 3) In all ATM-DATA request primitives, the "Submitted CLP" and "Congestion Indication" parameters shall be set to the same value as the SAR-LP and SAR-CI parameters, respectively, in the received SAR-UNITDATA invoke primitive.

#### **10.1.3 State variables for the SAR sublayer at the receiver side**

The SAR receiver maintains no state variables.

#### **10.1.4 Procedures of the SAR sublayer at the receiver side**

- 1) Upon receipt of an ATM-DATA indication primitive, the 48-octet SAR-PDU payload is sent to the CPCS. If the AUU parameter in the ATM-DATA indication primitive is set to "1", the More parameter is set to "0"; otherwise, the More parameter is set to "1".
- 2) In all SAR-UNITDATA signal primitives, the SAR-CI and the SAR-LP parameters shall be set to the same value as the "Congestion Indication" and the "Received Loss Priority" parameters, respectively, in the received ATM-DATA indication primitive.

### **10.2 Procedures of the CPCS for the Message Mode service**

The structure and coding of the CPCS-PDU is defined in 9.2.1.2.

#### **10.2.1 State variables of the CPCS at the sender side**

The CPCS-sender maintains no state variables.

### 10.2.2 Procedures of the CPCS at the sender side

Upon reception of a CPCS-UNITDATA invoke primitive, the CPCS-PDU is constructed as described in 9.2.1.2, and the CPCS-PDU is passed to the SAR sublayer in a SAR-UNITDATA invoke primitive with the More parameter set to "0". The SAR-LP and the SAR-CI parameters are set to the value of the CPCS-LP and the CPCS-CI parameters, respectively, of the CPCS-UNITDATA invoke primitive. The CPCS-UU field is assigned the value of the CPCS-UU parameter.

### 10.2.3 State variables of the CPCS at the receiver side

The CPCS receiver maintains the following state variable:

- *rcv\_LP*  
The *rcv\_LP* variable is initially set to zero and reset for each new CPCS-PDU. If any SAR-LP parameter is set to one, this variable is set to one. It is used to set the CPCS-LP parameter in the CPCS-UNITDATA signal primitive.

### 10.2.4 Procedures of the CPCS at the receiver side

The following procedures are specified for a CPCS receiver that does not deliver corrupted data to the receiving CPCS user. Optional delivery of corrupted data is defined in Annex E.

The CPCS receiver maintains the following parameter:

- *Max\_SDU\_Deliver\_Length*  
This parameter indicates the maximum size SDU, in octets that may be delivered to a CPCS user. At a receiver, the value of this parameter is compared to the length of each CPCS-SDU before it is delivered. Any CPCS-SDU that has a length greater than *Max\_SDU\_Deliver\_Length* is discarded and the event is reported to Layer Management. This parameter can take on any integer value from 1 to 65 535 and is set by the management plane.

NOTE – This procedure description may copy up to 47 octets of the PAD field into the reassembly buffer before processing the CPCS-PDU trailer.

- 1) When the CPCS receiver receives a SAR-UNITDATA signal primitive from the SAR sublayer, it shall copy the interface data to the reassembly buffer. If the SAR-LP parameter is set to one, the variable *rcv\_LP* is also set to one.
- 2) If the More parameter of the SAR-UNITDATA signal primitive is "1" and the received number of octets in the reassembly buffer of the CPCS-SDU is greater than the value of the parameter "*Max\_SDU\_Deliver\_Length*" plus 7, the CPCS receiver shall discard any information in the reassembly buffer.
- 3) If the More parameter of the SAR-UNITDATA signal primitive is "0", the last eight octets of the interface data represent the CPCS-PDU trailer. The CRC calculation, as specified in 9.2.1.2, is performed on the complete CPCS-PDU. If the value in the CRC field indicates the presence of errors, any information in the reassembly buffer shall be discarded.
- 4) If the value in the CPI field is not valid, any information in the reassembly buffer shall be discarded.
- 5) If the Length field of the CPCS-PDU trailer is coded as zero, any information in the reassembly buffer shall be discarded.
- 6) The Length field of the CPCS-PDU trailer is used to determine the length of the PAD field (length of received CPCS-PDU minus eight and minus the content of the Length field). If the PAD field is longer than 47 octets or not enough data has been received, any information in the reassembly buffer shall be discarded.

- 7) If the Length is greater than the Max\_SDU\_Deliver\_Length, any information in the reassembly buffer shall be discarded.
- 8) After the receipt of a SAR-UNITDATA signal primitive with the More parameter set to "0" and the data has not been discarded, any CPCS-SDU data in the reassembly buffer shall be delivered to the CPCS user via a CPCS-UNITDATA signal primitive. The CPCS-LP parameter shall be set to the value of the variable rcv\_LP. The CPCS-CI parameter shall be set to the value of the SAR-CI parameter received with the last SAR-UNITDATA signal primitive. The CPCS-UU parameter shall be set to the value of the CPCS-UU field of the CPCS-PDU trailer. Data that is delivered is removed from the reassembly buffer.
- 9) Whenever information from the reassembly buffer is delivered or discarded, the variable rcv\_LP is reset to zero.

If a reassembly timer is supported, the following procedures apply:

- 10) When the CPCS receiver receives a SAR-UNITDATA signal primitive from the SAR sublayer with the More parameter set to "1", the reassembly timer shall be (re)started.
- 11) When the CPCS receiver receives a SAR-UNITDATA signal primitive from the SAR sublayer with the More parameter set to "0", the reassembly timer shall be stopped.
- 12) If the timer expires, the CPCS receiver shall discard any information in the reassembly buffer.

Other reassembly timer procedures are for further study.

NOTE – The timer value is not specified in this Recommendation.

### 10.3 Procedures for the CPCS for the Streaming Mode service

These procedures are for further study.

### 10.4 Summary of parameters and values for an AAL type 5 connection

The information in Table 2 must be known at AAL type 5 connection establishment.

**Table 2/I.363.5 – Parameters and options for the AAL type 5**

Significance	Option/parameter	Value/Range
Peer-to-peer	Max_SDU_Deliver_Length	1 to 65 535 octets
Local (receiver)	Corrupted SDU delivery	No/yes
	Use and value of reassembly timer	No/yes-and value

# ANNEX A

## Details of the data unit naming convention

Details of the data unit naming convention are given in Figures A.1 and A.2.

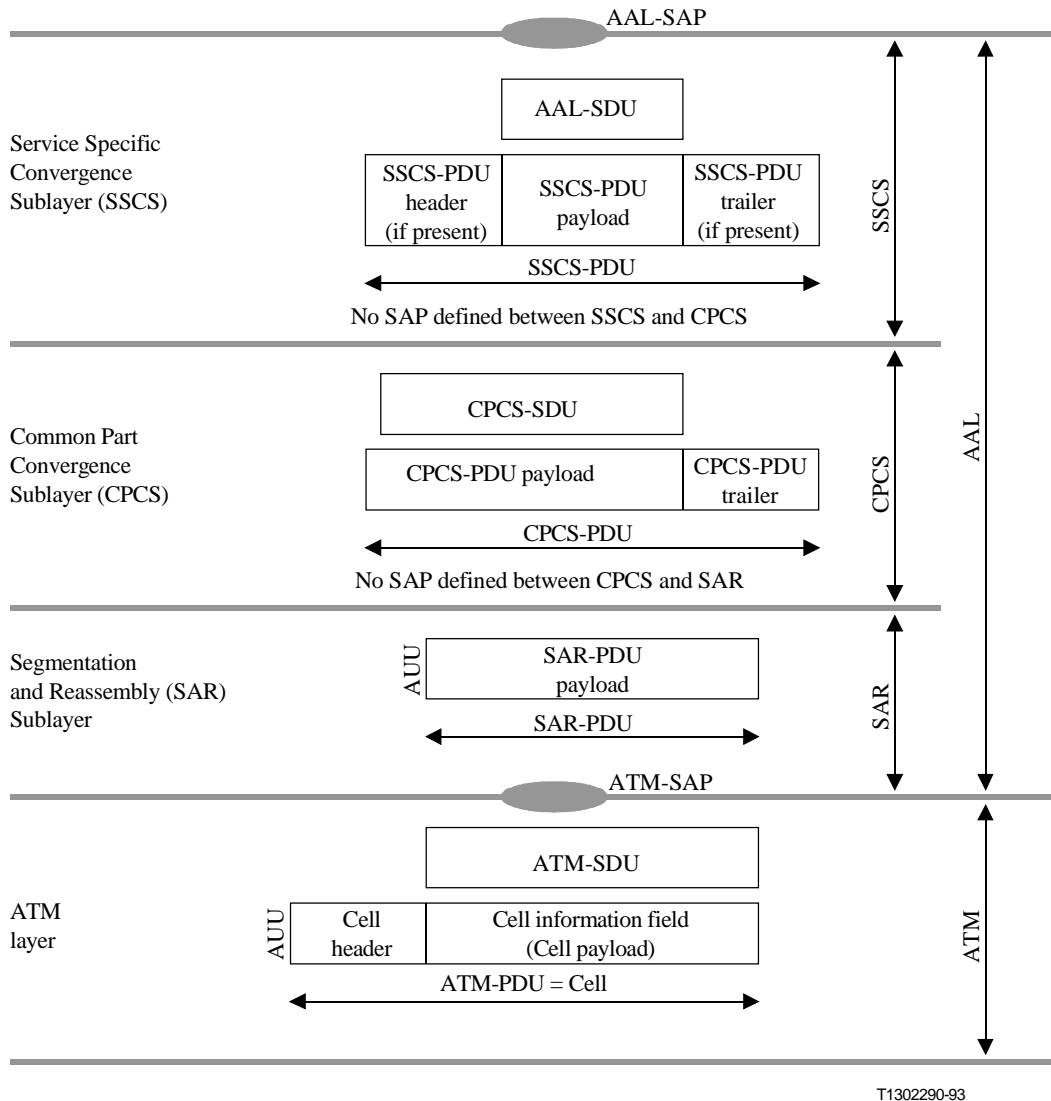

**Figure A.1/I.363.5 – Data unit naming conventions for the AAL type 5**

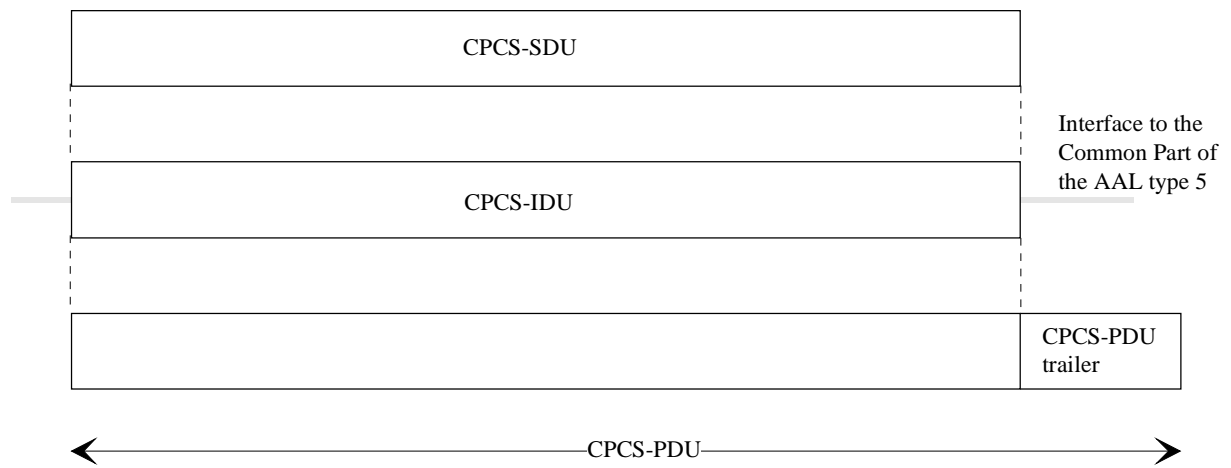

**a) Message Mode service**

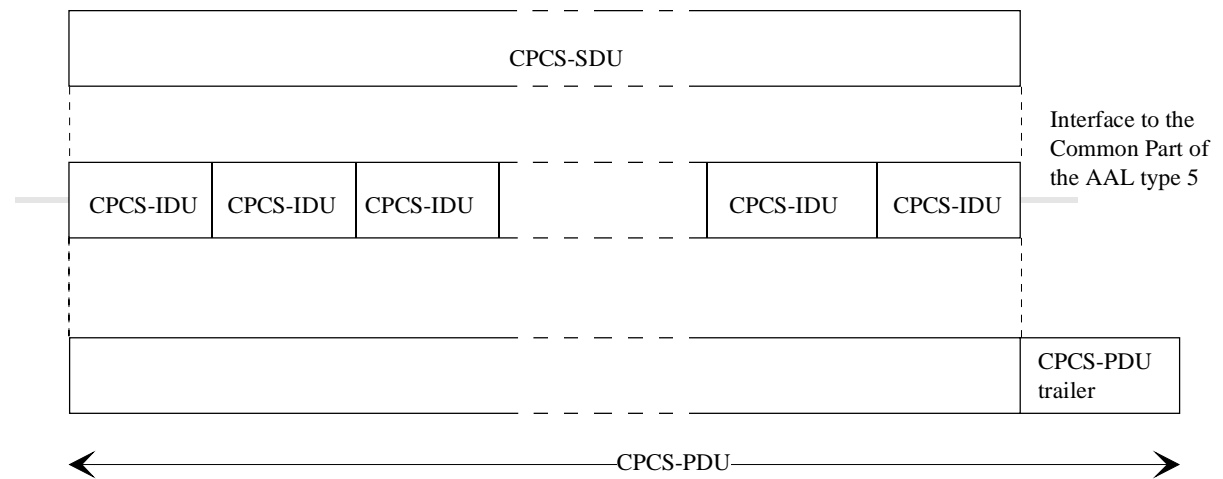

**b) Streaming Mode service**

T1311210-97

**Figure A.2/I.363.5 – Message and Streaming modes of service at the AAL type 5 interface**

## ANNEX B

### General framework of the AAL type 5

This annex provides a description of the general framework of the AAL type 5 including SAR and CPCS-PDU formats.

#### B.1 Message segmentation and reassembly

Figure B.1 provides a generic interpretation of the segmenting of a SAR-SDU (message) into SAR-PDUs where the AUU bit in the header of the associated ATM-SDU is set to "0" and the last SAR-PDU where the AUU bit is set to "1".

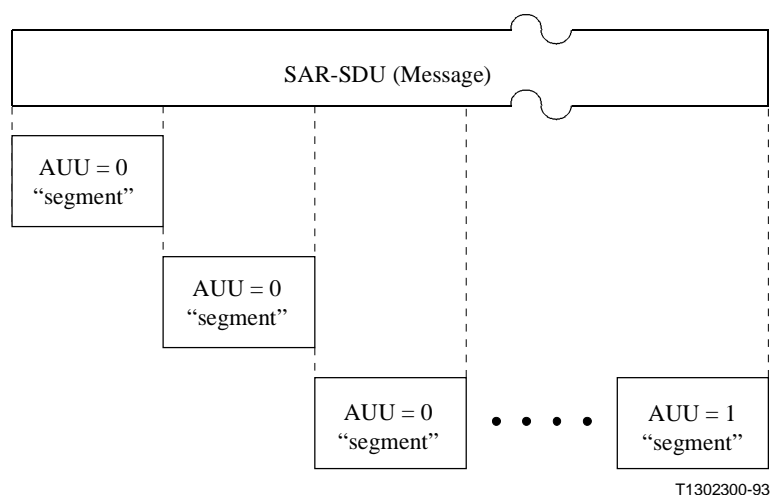

Figure B.1/I.363.5 – Message segmentation and reassembly

#### B.2 PDU headers, trailers and terminology

Figure B.2 builds on the generic view of message segmentation of Figure A.1 to incorporate the relevant PDU headers and trailers and appropriate terminology on the basis of the AUU bit being set to "0" or "1".

#### B.3 Examples of the segmentation and reassembly process

Figure B.3 shows schematically a successful segmentation and reassembly of a CPCS user PDU in message mode.



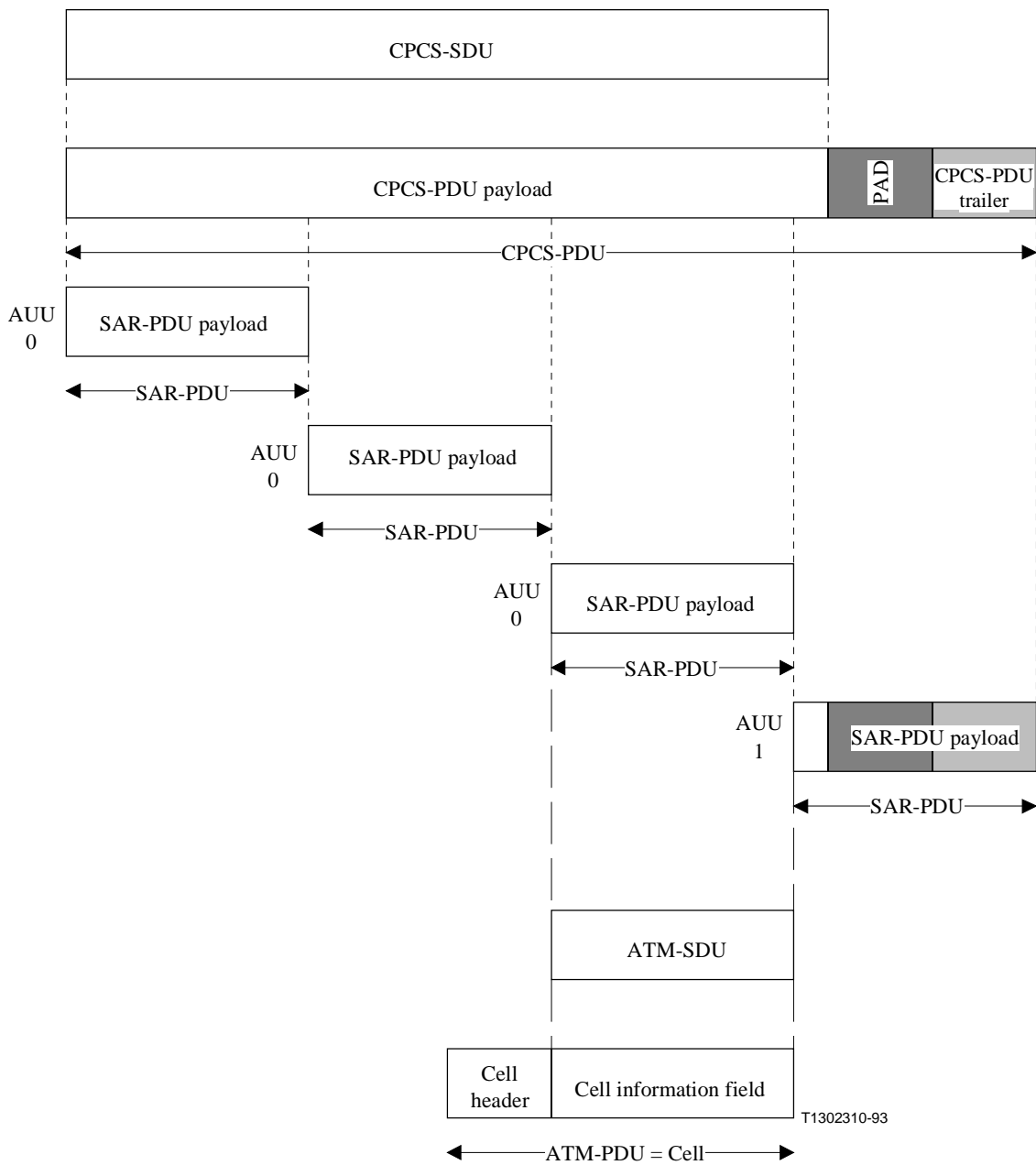

**Figure B.2/I.363.5 – PDU headers, trailers and terminology**

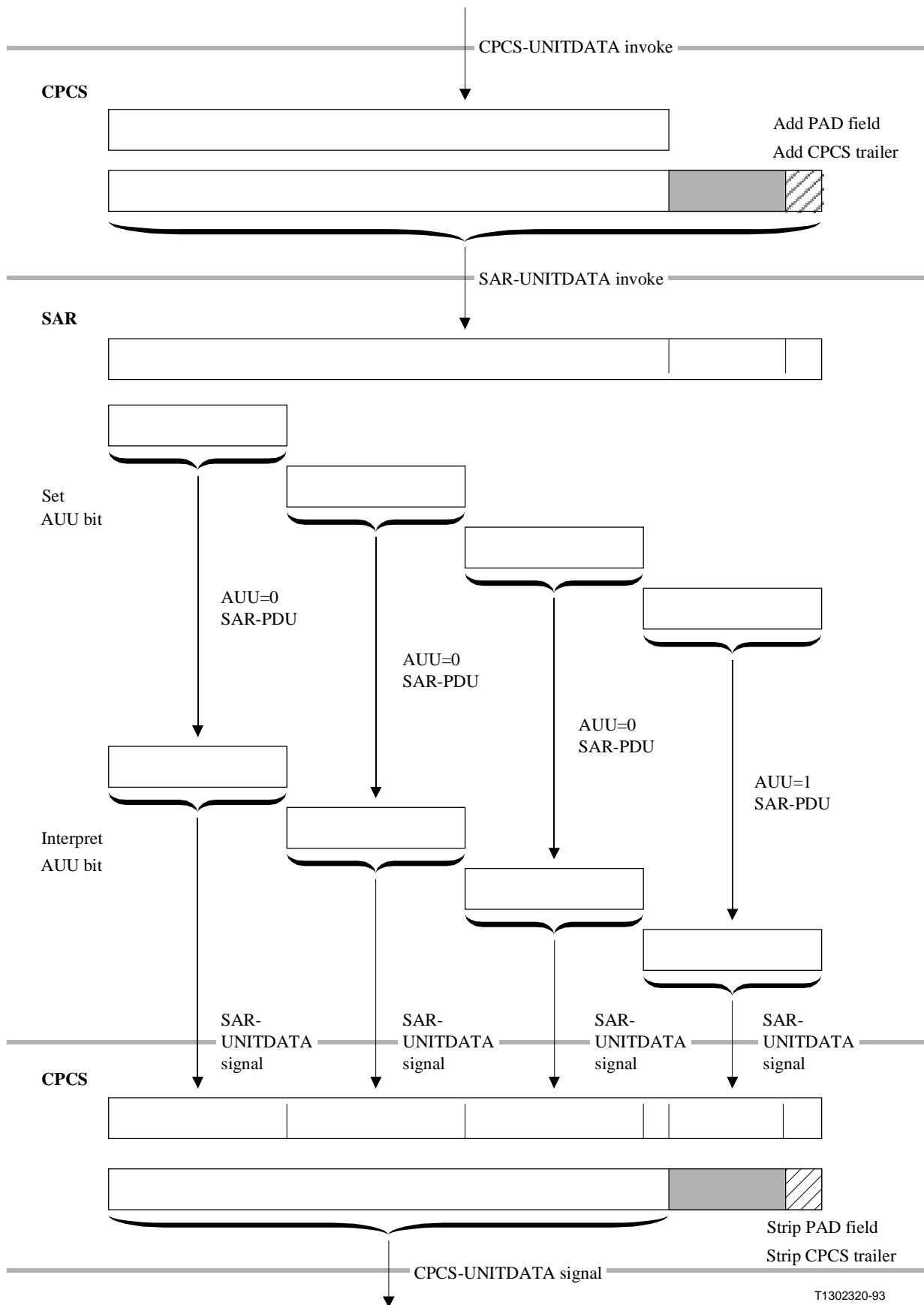

T1302320-93

**Figure B.3/I.363.5 – Successful segmentation and reassembly of a CPCS user PDU**

## ANNEX C

### Functional model for the AAL type 5

For the AAL type 5, the functionality of the SSCS may provide only for the mapping of the equivalent primitives of the AAL to the CPCS and vice versa. On the other hand, the SSCS may implement functions such as assured data transfer. Such functions, however, are not shown in Figures C.1 and C.2.

The functional model of the AAL type 5 at the sender side is shown in Figure C.1. The model consists of several blocks that cooperate to provide the AAL type 5 service. The SAR and CPCS blocks that are paired represent the segmentation state machine.

The functional model of the AAL type 5 at the receiver side is shown in Figure C.2. The model consists of several blocks that cooperate to provide the AAL type 5 service. The SAR and CPCS blocks that are paired represent the reassembly state machine.

NOTE – Layer management interactions require further study.

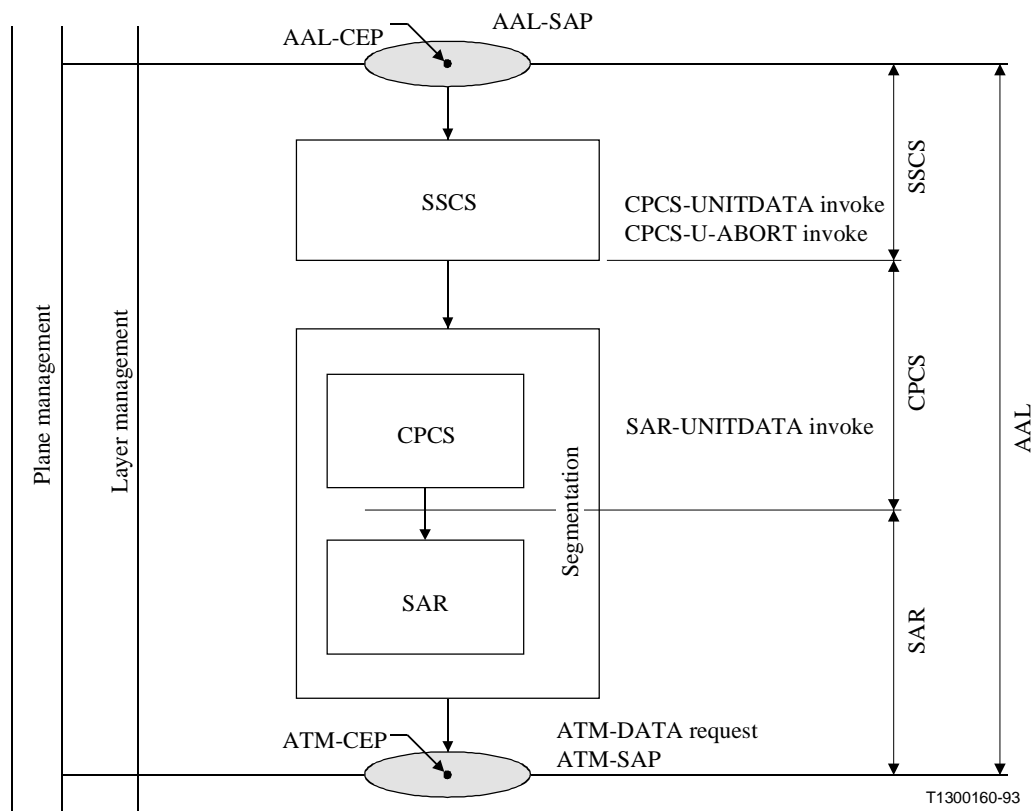

**Figure C.1/I.363.5 – Functional model for the AAL type 5 (sender side)**

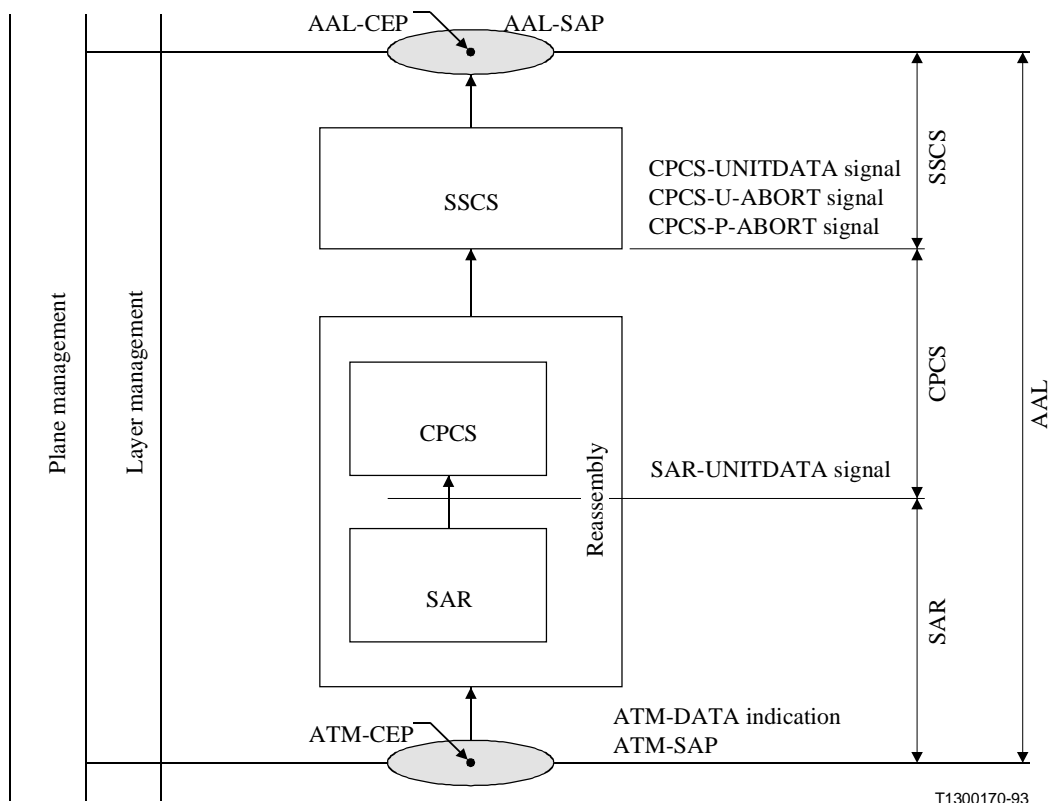

NOTE – Concerning the SSCS, the functional model is an example only. Possible functions in the SSCS (i.e. multiplexing) are not shown. The SSCS is specified in other Recommendations.

**Figure C.2/I.363.5 – Functional model for the AAL type 5 (receiver side)**

## ANNEX D

### SDL diagram for the SAR and the CPCS of the AAL type 5

Procedures for delivery of corrupted data are not included in this annex; CPCS procedures for Streaming Mode are not included in this annex. SDL diagrams for the corrupted data delivery option are shown in Annex E.

NOTE – Implementations may or may not make the boundary between the CPCS and the SAR sublayer visible and accessible.

#### D.1 SDL for the SAR sublayer

This subclause contains the SDL specifications for the SAR procedures of the AAL type 5.

##### D.1.1 The SAR sender

The SAR sender makes use of two variables:

a) *ptrPDU*

This is a temporary variable that points into the (partial) CPCS-PDU received via the SAR-UNITDATA invoke primitive. As successive parts of the CPCS-PDU are filled into SAR-PDU payloads, this pointer keeps pointing at the first octet within the CPCS-PDU that has not yet been sent within an SAR-PDU.

b) *count*

This temporary variable keeps track of the number of octets still awaiting segmentation and transmission within an SAR-PDU.

NOTE – No interactions with layer management are shown; these interactions require further study.

### **D.1.2 The SAR receiver**

The SAR receiver maintains no variables.

NOTE – No interactions with layer management are shown; these interactions require further study.

## **D.2 SDL for the Common Part CS (CPCS) procedures**

This subclause contains the SDL specifications for the CPCS procedures of the AAL type 5.

### **D.2.1 The CPCS sender**

The CPCS sender maintains no variables.

NOTE – No interactions with layer management are shown; these interactions require further study.

### **D.2.2 The CPCS receiver**

The CPCS receiver makes use of the state variable *rcv\_LP* (as defined in 10.2.3). In addition, the CPCS receiver utilizes one variable:

– *reassembly buffer*

In the model of the SDL diagrams, the reassembly buffer is allocated while processing the CPCS-PDU and freed once the reassembly of a CPCS-PDU is complete (or abandoned due to errors).

NOTE – No interactions with layer management are shown; these interactions require further study.

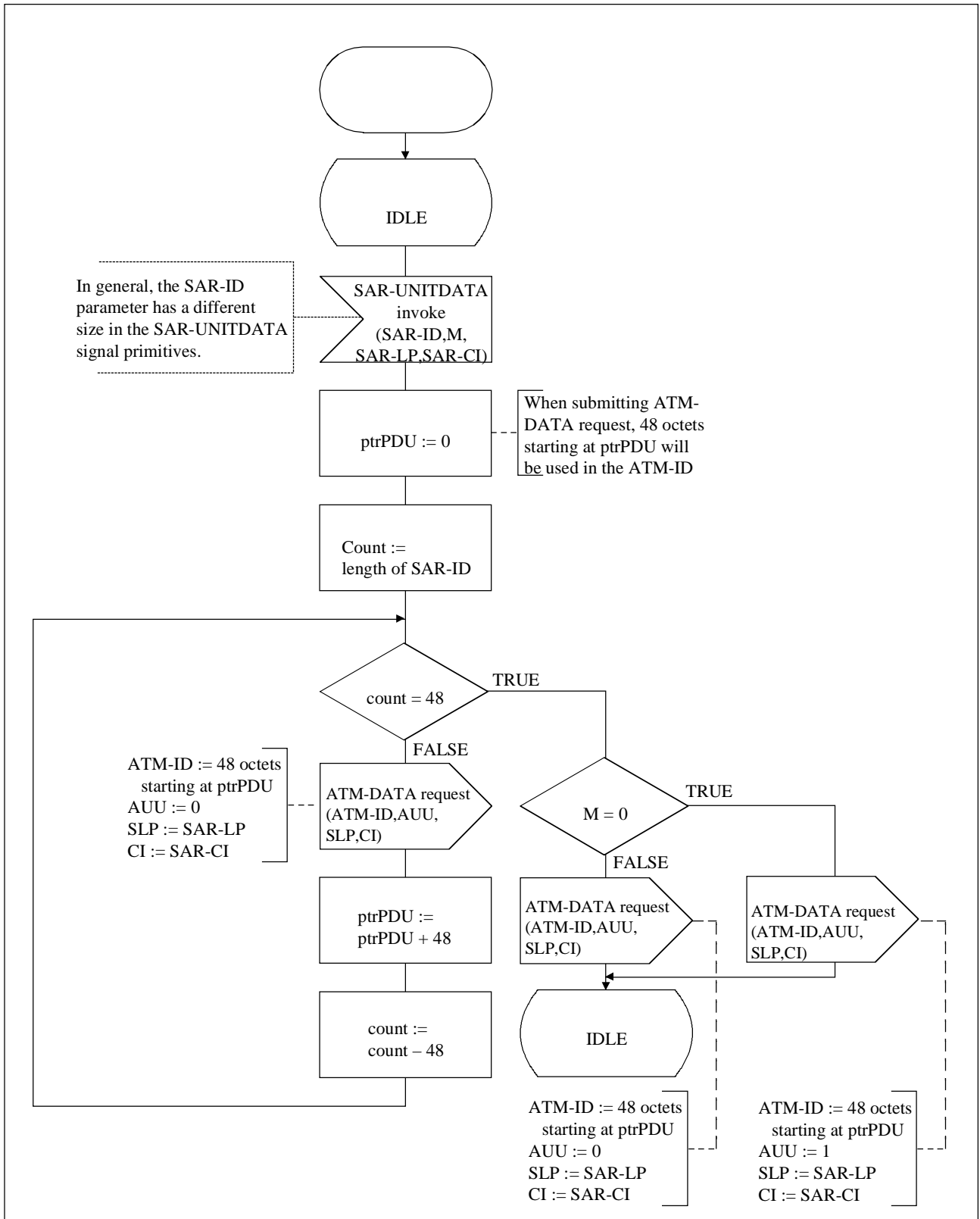

T1306960-95

Figure D.1/I.363.5 – SDL diagrams for the SAR sender

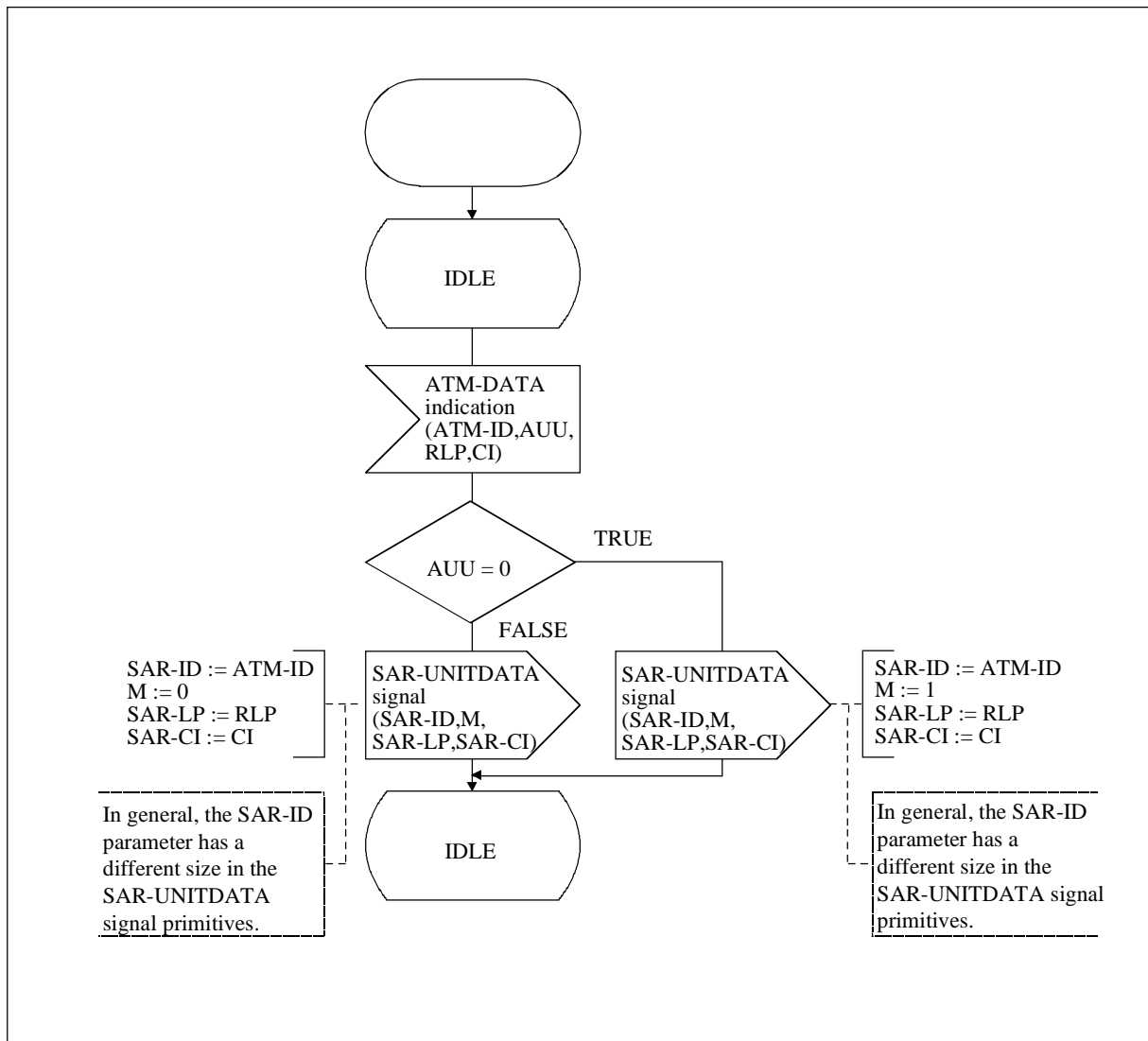

T1306970-95

**Figure D.2/I.363.5 – SDL diagrams for the SAR receiver**

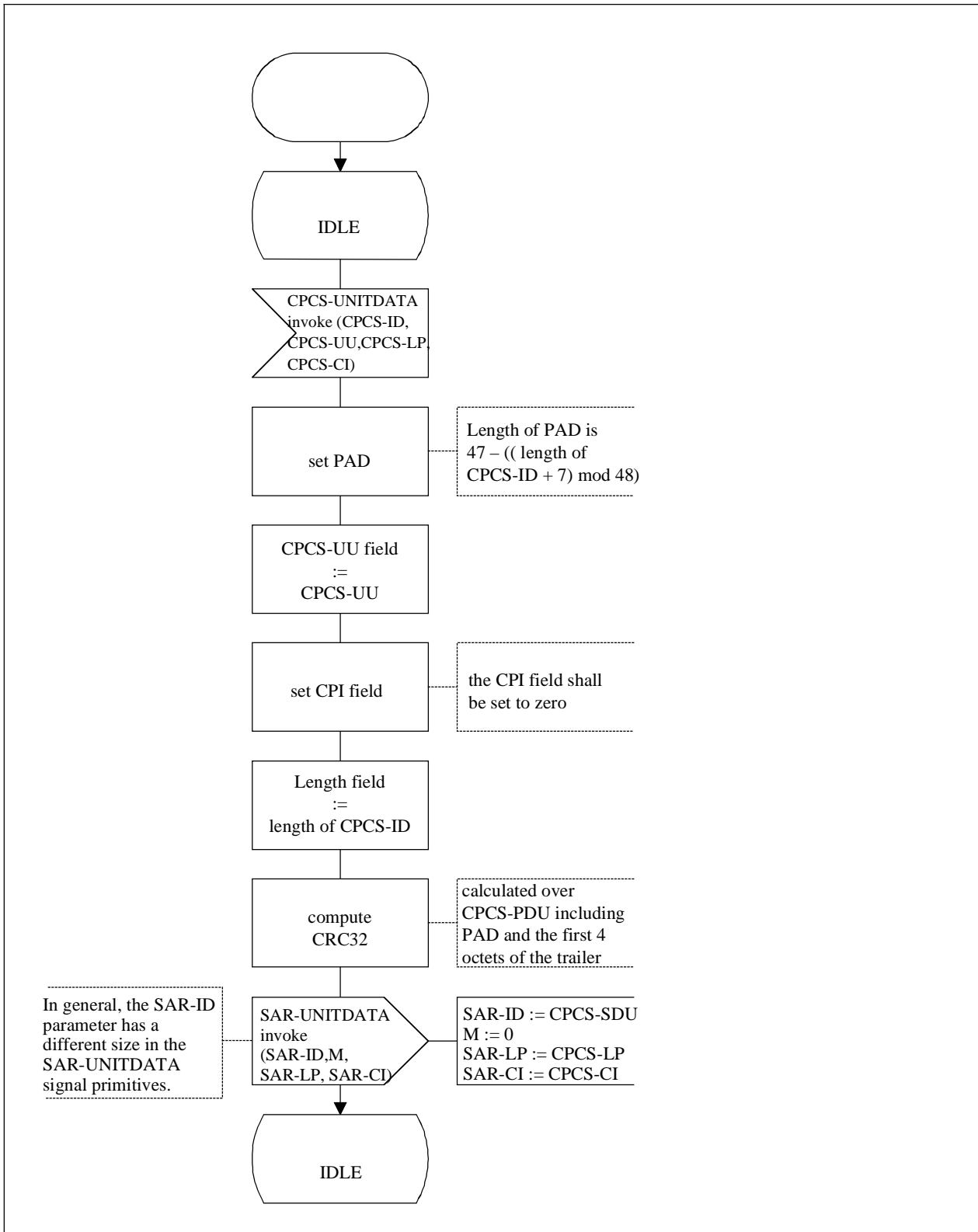

T1306980-95

Figure D.3/I.363.5 – SDL diagrams for the CPCS sender



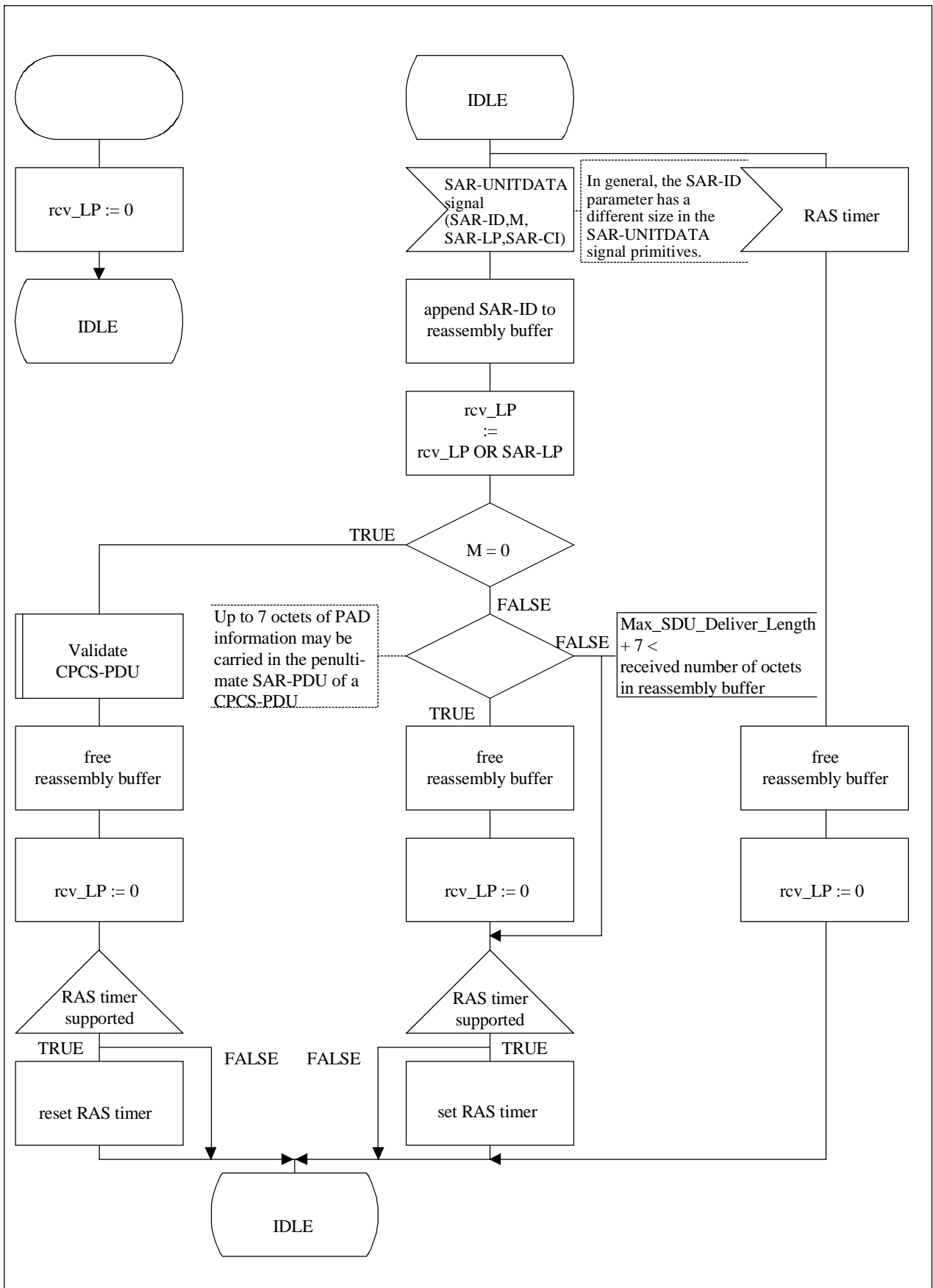

T1306990-95

Figure D.4/I.363.5 (sheet 1 of 2) – SDL diagrams for the CPCS receiver

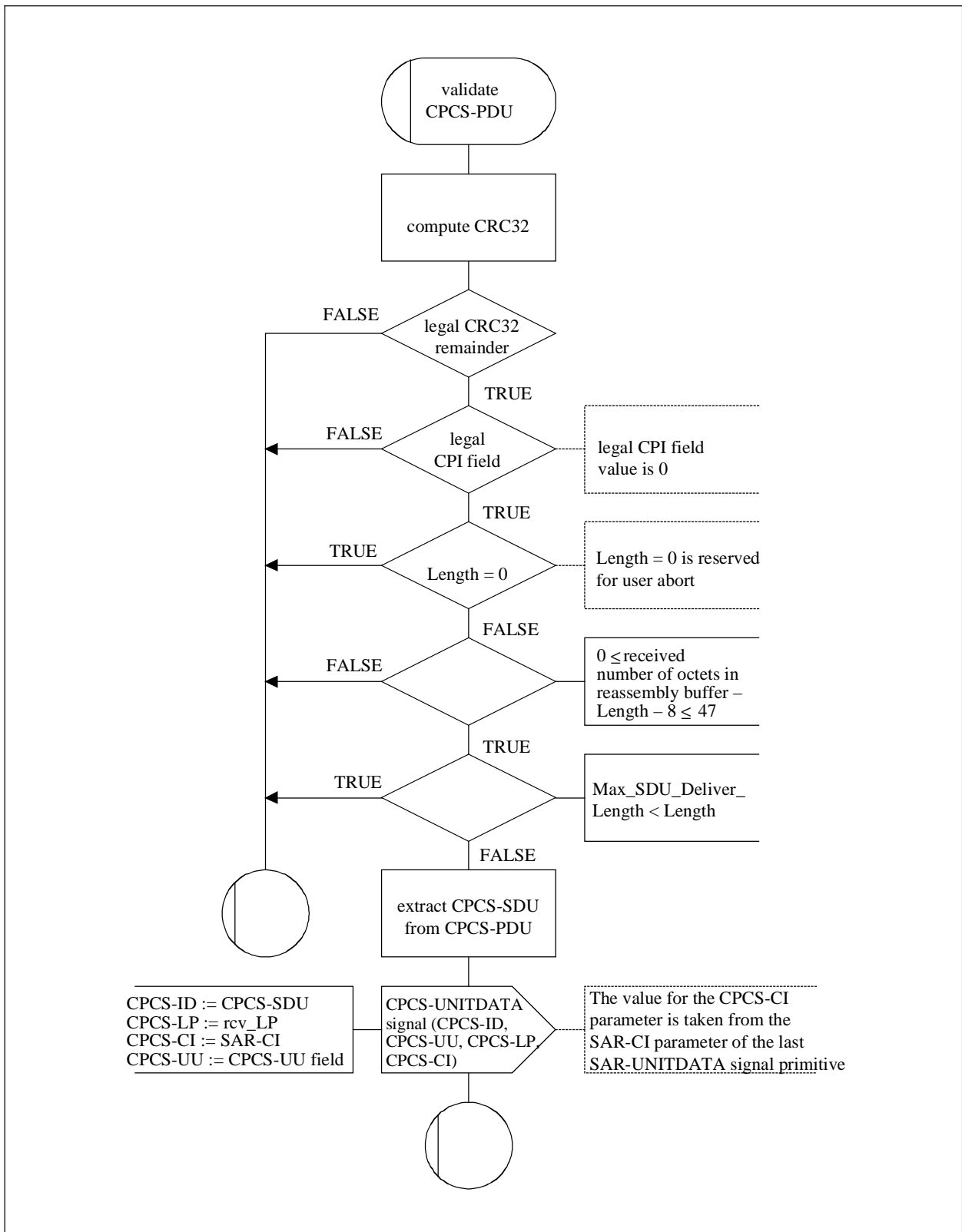

T1307000-95

Figure D.4/I.363.5 (sheet 2 of 2) – SDL diagrams for the CPCS receiver

## ANNEX E

### Corrupted data delivery option

#### E.1 Service provided by corrupted data delivery option

This annex specifies the protocol and procedures used to provide an optional service consisting of the delivery of AAL 5 CPCS-SDUs detected as corrupted. If the corrupted data delivery option is not enabled, corrupted CPCS-SDUs are discarded in accordance with the procedures in clause 10. If the corrupted data delivery option is enabled, corrupted CPCS-SDUs are delivered to the SSCS, along with an indication of the error type, in accordance with the procedures specified in this annex.

The service delivered by CPCS AAL 5 when the corrupted data delivery option is selected is such that:

- When a non corrupted PDU is received, the CPCS-SDU, as received by the peer CPCS, is delivered to the CPCS user together with an "OK" Reception Status parameter.
- When a corrupted PDU is received, the CPCS-SDU assumed to be received and delivered to the CPCS user corresponds to the reassembly buffer without the last eight octets, which are assumed to constitute the trailer of the PDU; the assumed CPCS-SDU is delivered together with a Reception Status that lists the various types of errors detected and three elements including the assumed CPI, assumed Length and assumed CRC remainder.

NOTE – The CPCS user must recognize that if a Length error is indicated, even though no CRC error has been detected, there is no guarantee that the CRC found is actually good; that is, the CRC error detection mechanism used in AAL 5 is not as reliable when a cell belonging to the PDU has been lost (or misinserted). Conversely, the indication that no Length error has been detected cannot be relied upon if a CRC error has been detected. The actual determination of the type of error that has been encountered may be done only on the basis of a heuristic method weighted by the probability of occurrence of that combination of errors. The probability may be determined on the basis of the quality of the service which is expected from the particular underlying ATM connection and the characteristics of the user of this service. Appendix II gives some information on the possible combinations of errors that may occur and the conclusion that may be drawn concerning the user data recovered.

- Some losses in the network may be such that some PDUs are not detected at all by the CPCS receiver; consequently, no indication is given to the CPCS user in this case.

#### E.2 Parameter definitions

The parameters of the CPCS-UNITDATA primitives are defined in 7.2.1; for the corrupted data delivery option, the parameter definition is augmented with:

- **Reception Status (RS)**

This parameter is used at the CPCS receiver to indicate to the CPCS user which errors, if any, have been detected by the CPCS receiver and to pass portions of the CPCS-PDU that may be helpful for the CPCS user to recover from these errors. For modeling purposes, The Reception Status may be considered to contain the elements shown in Figure E.1.

The elements of the RS parameter have the following significance for modeling purposes:

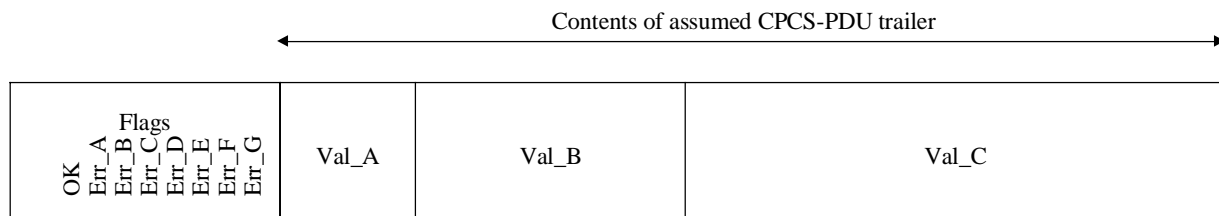

T1307370-95

**Figure E.1/I.363.5 – Model of the Reception Status parameter**

a) **RS.Flags**

Indicates the status of the CPCS-SDU that is being delivered; this element is modelled as a set of flags representing the errors detected:

RS.Flags  $\subset$  {OK, Err\_A, Err\_B, Err\_C, Err\_D, Err\_E, Err\_F, Err\_G}

where

"OK" is set if no errors were detected;

"Err\_A" is set if an illegal CRC remainder was detected;

"Err\_B" is set if an illegal CPI was detected;

"Err\_C" is set if the value of the Length field in the perceived CPCS-PDU trailer is 0;

"Err\_D" is set if an illegal length of a PAD field was detected;

"Err\_E" is set if the value of the Length field in the perceived CPCS-PDU trailer exceeds the value of the Max\_SDU\_Deliver\_Length parameter;

"Err\_F" is set if the CPCS-SDU length exceeds the value of the Max\_Corrupted\_SDU\_Deliver\_Length parameter;

"Err\_G" is set if a reassembly timer expiry has occurred prior to completion of the CPCS-SDU assembly.

NOTE – In the representation described, a flag is present in RS.Flags if and only if it is set.

- b) RS.Val\_A contains the second octet of the assumed CPCS-PDU trailer (CPI); if RS.Flag = { OK }, this field shall be ignored and may not be present.
- c) RS.Val\_B contains the third and fourth octets of the assumed CPCS-PDU trailer (Length); if RS.Flag = { OK }, this field shall be ignored and may not be present.
- d) RS.Val\_C contains the last four octets of the assumed CPCS-PDU trailer (CRC); if RS.Flag = { OK }, this field shall be ignored and may not be present.

**E.3 Procedures to provide corrupted data delivery for the message mode service**

The procedures for the SAR sublayer (see 10.1) and for the CPCS at the sender side (see 10.2.1) apply. The procedures of the CPCS receiver are defined below (i.e. replacing the definition in 10.2.2).

The CPCS receiver maintains the following parameters:

**Max\_SDU\_Deliver\_Length**

This parameter indicates the maximum size SDU, in octets, that may be delivered to a CPCS user. At a receiver, the value of this parameter is compared to the length of each CPCS-SDU before it is delivered. When the corrupted data delivery option is not enabled, any CPCS-SDU that has a length greater than Max\_SDU\_Deliver\_Length is discarded and the event is reported to Layer Management. When it is enabled, any assumed CPCS-SDU that has a length greater than Max\_SDU\_Deliver\_Length is delivered to the CPCS user and the appropriate error flag is set in the

RS.Flags parameter. Max\_SDU\_Deliver\_Length can take on any integer value from 1 to 65 535 and is set by the management plane.

### **Max\_Corrupted\_SDU\_Deliver\_Length**

This parameter indicates the maximum number of octets of an assumed CPCS-SDU that may be delivered to the CPCS user when the corrupted data delivery option is enabled. The value assigned to this parameter is implementation specific and may be set to the reassembly buffer length minus eight octets. It shall be set to a value greater than Max\_SDU\_Deliver\_Length. This parameter is a local parameter and is set by the management plane.

NOTE – If the Max\_Corrupted\_SDU\_Deliver\_Length is set to an integral multiple of 48 plus 40 octets, then all data received will be passed up to the CPCS user.

- 1) When the CPCS receiver receives a SAR-UNITDATA signal primitive from the SAR sublayer, it shall copy the interface data to the reassembly buffer. If the SAR-LP parameter is set to "1", the variable rcv\_LP is also set to "1". The CPCS receiver checks if the corrupted data delivery option is enabled. If it is not enabled, processing proceeds as described in 10.2.4.
- 2) If the More parameter of the SAR-UNITDATA signal primitive is "1" and the received number of octets of the CPCS-SDU in the reassembly buffer is greater than or equal to the value of the parameter "Max\_Corrupted\_SDU\_Deliver\_Length" plus eight, the CPCS receiver shall set Err\_F flag and proceed with item 9) below.
- 3) If the More parameter of the SAR-UNITDATA signal primitive is "0", the last eight octets of the interface data are assumed to represent the CPCS-PDU trailer. The CRC calculation, as specified in 9.2.1.2, is performed on the complete CPCS-PDU. If the value in the CRC field indicates the presence of errors, the CPCS receiver shall set the Err\_A flag.
- 4) If the value in the CPI field is not valid, the CPCS receiver shall set the Err\_B flag.
- 5) If the Length field of the CPCS-PDU trailer is coded as zero and neither a CRC error nor an illegal CPI field has been encountered, any information in the reassembly buffer shall be discarded. Otherwise, if the Length field is zero and other errors were detected, the CPCS receiver shall set the Err\_C flag and the CPCS receiver proceeds with step 9) below.
- 6) The assumed Length field of the CPCS-PDU trailer is used to determine the length of the PAD field (length of the reassembly buffer minus eight and minus the content of the assumed Length field). If the PAD field is longer than 47 octets or if not enough data has been received, the CPCS receiver shall set the Err\_D flag.
- 7) If the value of the Length field is larger than the value of Max\_SDU\_Deliver\_Length and no other errors were detected, any information in the reassembly buffer shall be discarded. Otherwise, if the value of the Length field is larger than the value of Max\_SDU\_Deliver\_Length and other errors were detected, the CPCS receiver shall set the Err\_E flag and the CPCS receiver proceeds with step 9) below.
- 8) After receipt of a SAR-UNITDATA signal primitive with the More parameter set to "0" and no errors have been detected, any CPCS-SDU data in the reassembly buffer shall be delivered to the CPCS user via a CPCS-UNITDATA signal primitive. The CPCS-LP parameter shall be set to the value of the variable rcv\_LP. The CPCS-CI parameter shall be set to the value of the SAR-CI parameter received with the last SAR-UNITDATA signal primitive. The CPCS-UU parameter shall be set to the value of the CPCS-UU field of the CPCS-PDU trailer. The RS parameter is set to { OK }.

Data that is delivered is removed from the reassembly buffer.

- 9) If errors have been detected, all but the last eight octets of the data in the reassembly buffer shall be delivered to the CPCS user via a CPCS-UNITDATA signal primitive as a possible CPCS-SDU. The CPCS-UU parameter shall be set to the value of the CPCS-UU field of the assumed CPCS-PDU trailer. The CPCS-LP parameter shall be set to the value of the variable rcv\_LP. The CPCS-CI parameter shall be set to the value of the SAR-CI parameter received with the last SAR-UNITDATA signal primitive. The RS parameter contains four items:
- in the RS.Flags element, an indication of all the error types detected (the inclusive OR of the error flags);
  - in the RS.Val\_A element, the contents of the second octet of the assumed CPCS-PDU trailer (possible CPI field);
  - in the RS.Val\_B element, the contents of the third and fourth octets of the assumed CPCS-PDU trailer (possible Length field); and
  - in the RS.Val\_C element, the contents of the last four octets of the assumed CPCS-PDU trailer (possible CRC field).

NOTE – Effectively, the entire received information in the reassembly buffer is passed to the CPCS user. This information plus the indication of the detected error types allow the user to possibly recover from certain errors in an application specific manner.

Data that is delivered is removed from the reassembly buffer.

- 10) Whenever information from the reassembly buffer is delivered or discarded, the variable rcv\_LP is reset to "0" and all flags of the Reception Status (RS.Flags) are reset.

If a reassembly timer is supported, the following procedures apply:

- 11) When the CPCS receiver receives a SAR-UNITDATA signal primitive from the SAR sublayer with the More parameter set to "1", the reassembly timer shall be (re)started.
- 12) When the CPCS receiver receives a SAR-UNITDATA signal primitive from the SAR sublayer with the More parameter set to "0", the reassembly timer shall be stopped.
- 13) If the timer expires and the corrupted data delivery option is not enabled, the CPCS receiver shall discard any information in the reassembly buffer.
- 14) If the timer expires and the corrupted data delivery option is enabled, the CPCS receiver shall set the Err\_G flag to indicate timer expiry prior to completion of CPCS-SDU assembly. Processing continues with step 9) above.

Other reassembly timer procedures are for further study.

NOTE – The value of the reassembly timer is not specified in this Recommendation.

#### **E.4 Procedures to provide corrupted data delivery for the streaming mode service**

These procedures are for further study. Whether these procedures impact interworking with the Message Mode service is also for further study.

#### **E.5 SDL representation of procedures to provide corrupted data delivery**

No Streaming Mode procedures are included in this subclause.

This subclause contains the SDL representation of the procedures, described in E.3, for the CPCS receiver when the corrupted data delivery option is supported by an implementation. The SDL diagrams of the SAR procedures and those of the CPCS sender are the same as for implementations that do not support corrupted data delivery option, and are specified in Annex D. If there exists any difference detected between the prose description in E.3 and the SDL diagrams in E.5, the SDL diagrams in E.5 shall take precedence.

The CPCS receiver makes use of the state variable `rcv_LP` (as defined in 10.2.3). In addition, the CPCS receiver utilizes one variable:

- *Reassembly buffer*

In the model of the SDL diagrams, the reassembly buffer is allocated while processing the CPCS-PDU and freed once the reassembly of a CPCS-PDU is complete and the CPCS-SDU is delivered or discarded.

In addition, the CPCS receiver makes use of a temporary variable "RS" in the "Validate CPCS-PDU" macro; this variable is structured the same as the Reception Status (RS) parameter.

NOTE – No interactions with layer management are shown; these interactions require further study.

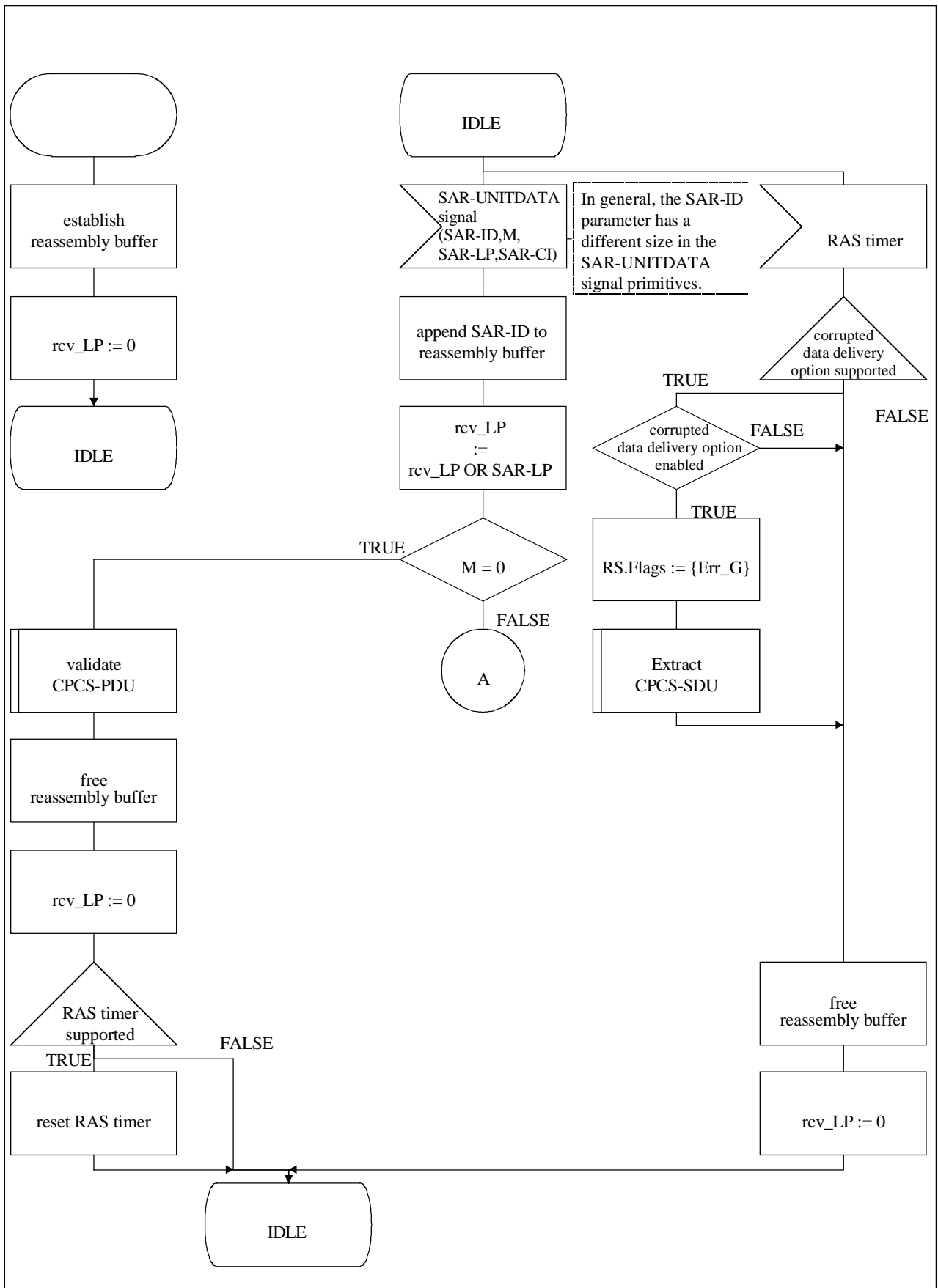

T1307380-95

Figure E.2/I.363.5 (sheet 1 of 6) – CPCS receiver for the corrupted data delivery option



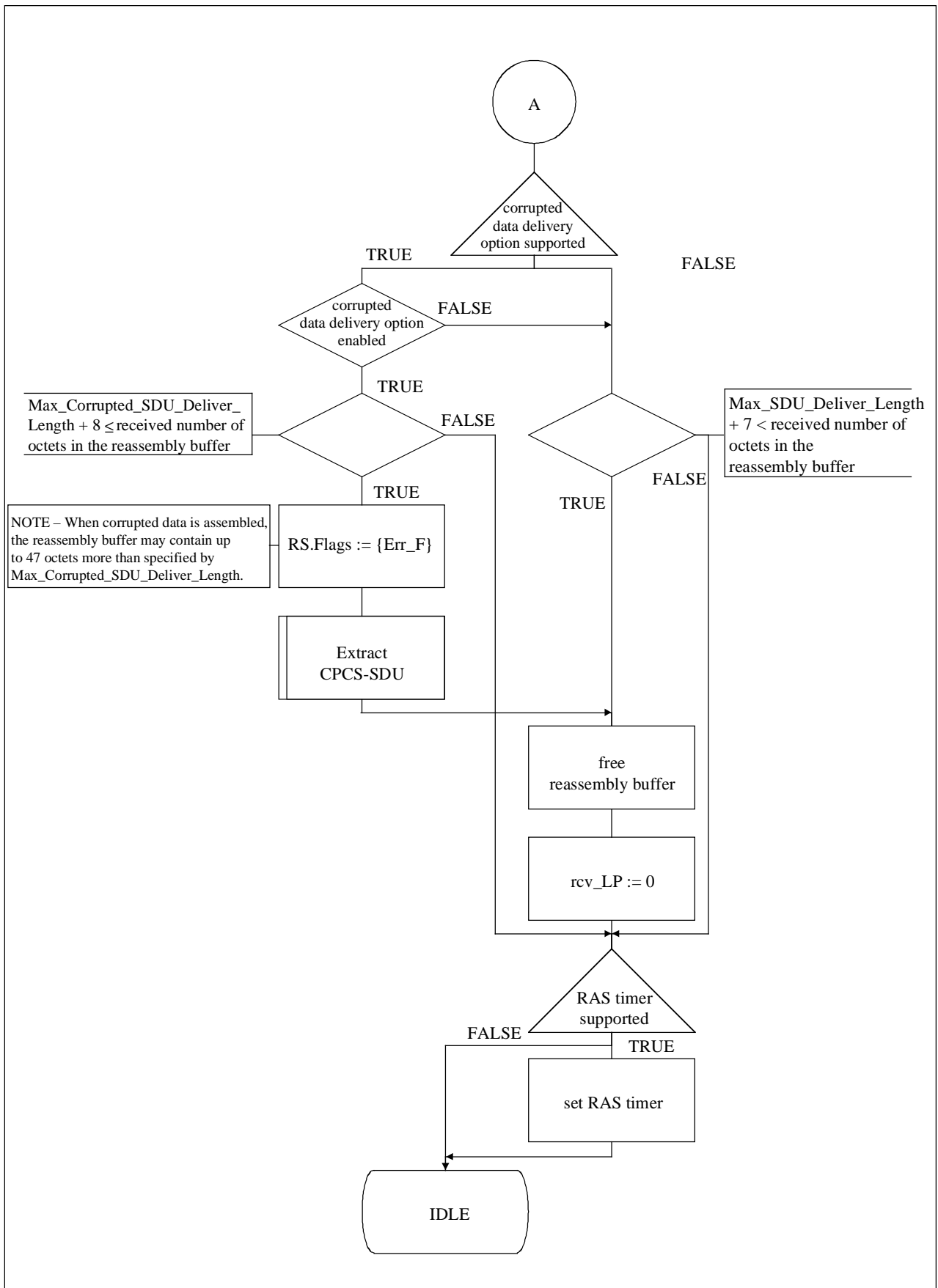

T1307390-95

Figure E.2/I.363.5 (sheet 2 of 6) – CPCS receiver for the corrupted data delivery option

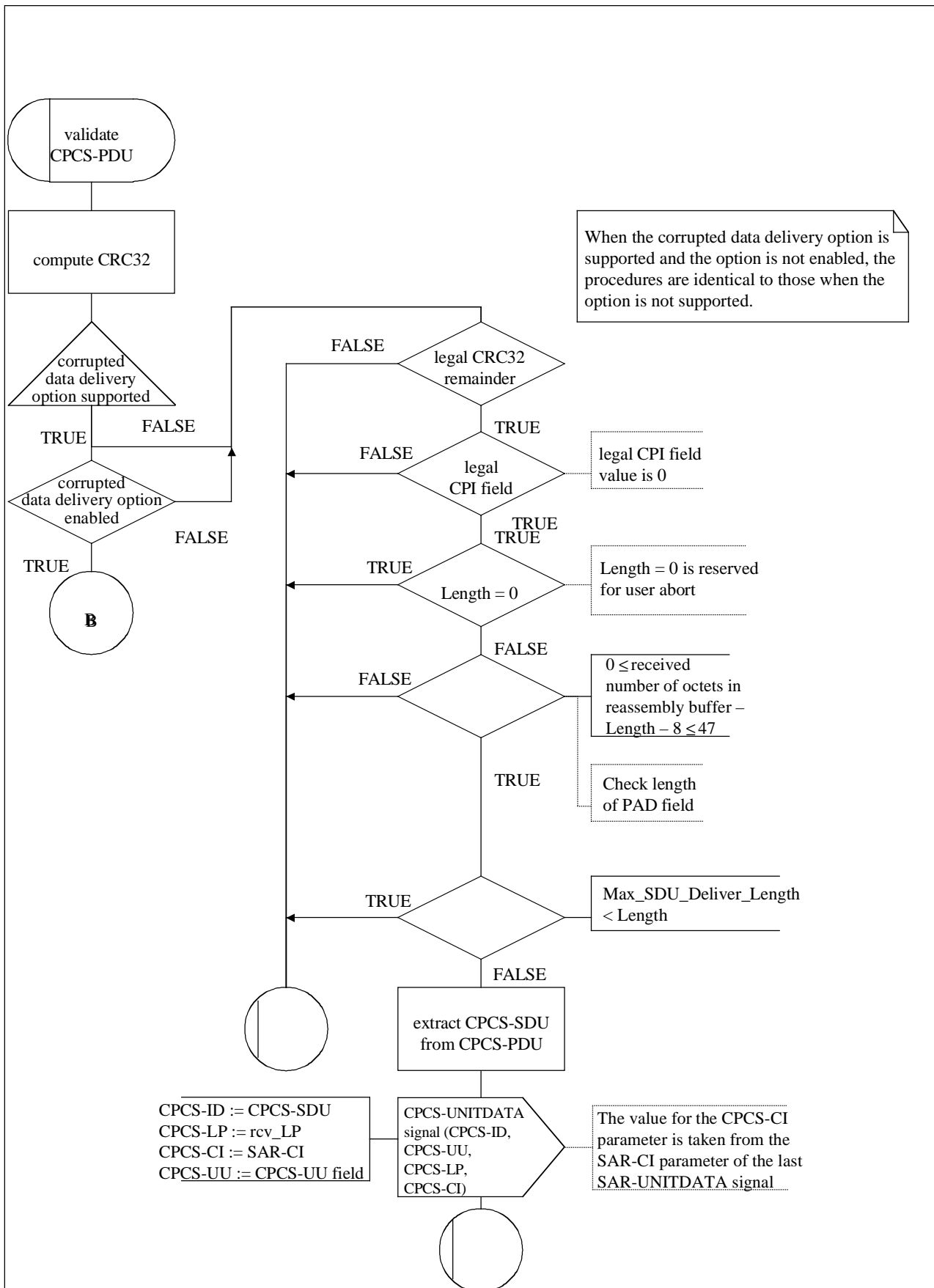

T1307400-95

Figure E.2/I.363.5 (sheet 3 of 6) – CPCS receiver for the corrupted data delivery option

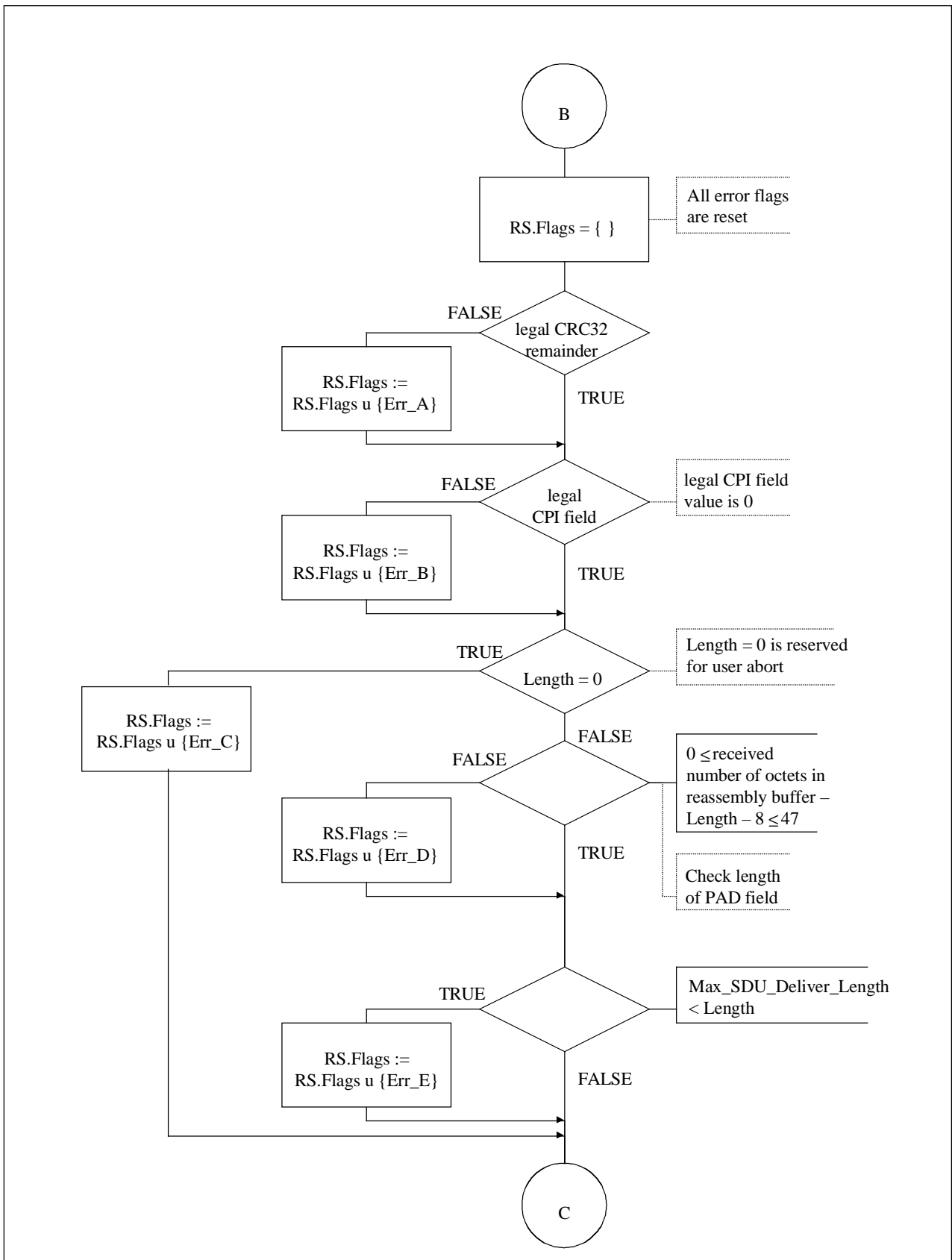

T1307410-95

Figure E.2/I.363.5 (sheet 4 of 6) – CPCS receiver for the corrupted data delivery option

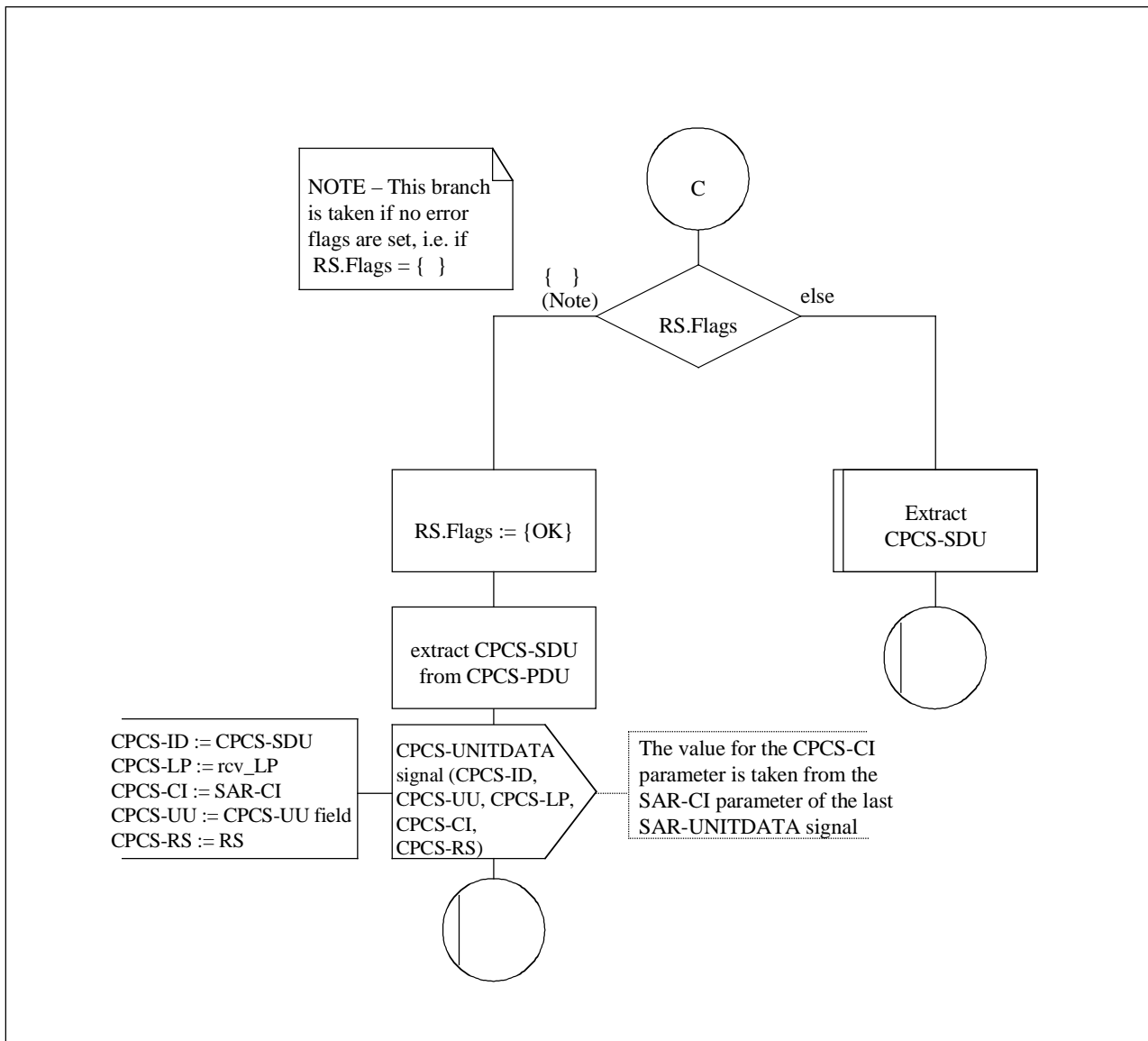

T1307420-95

Figure E.2/I.363.5 (sheet 5 of 6) – CPCS receiver for the corrupted data delivery option

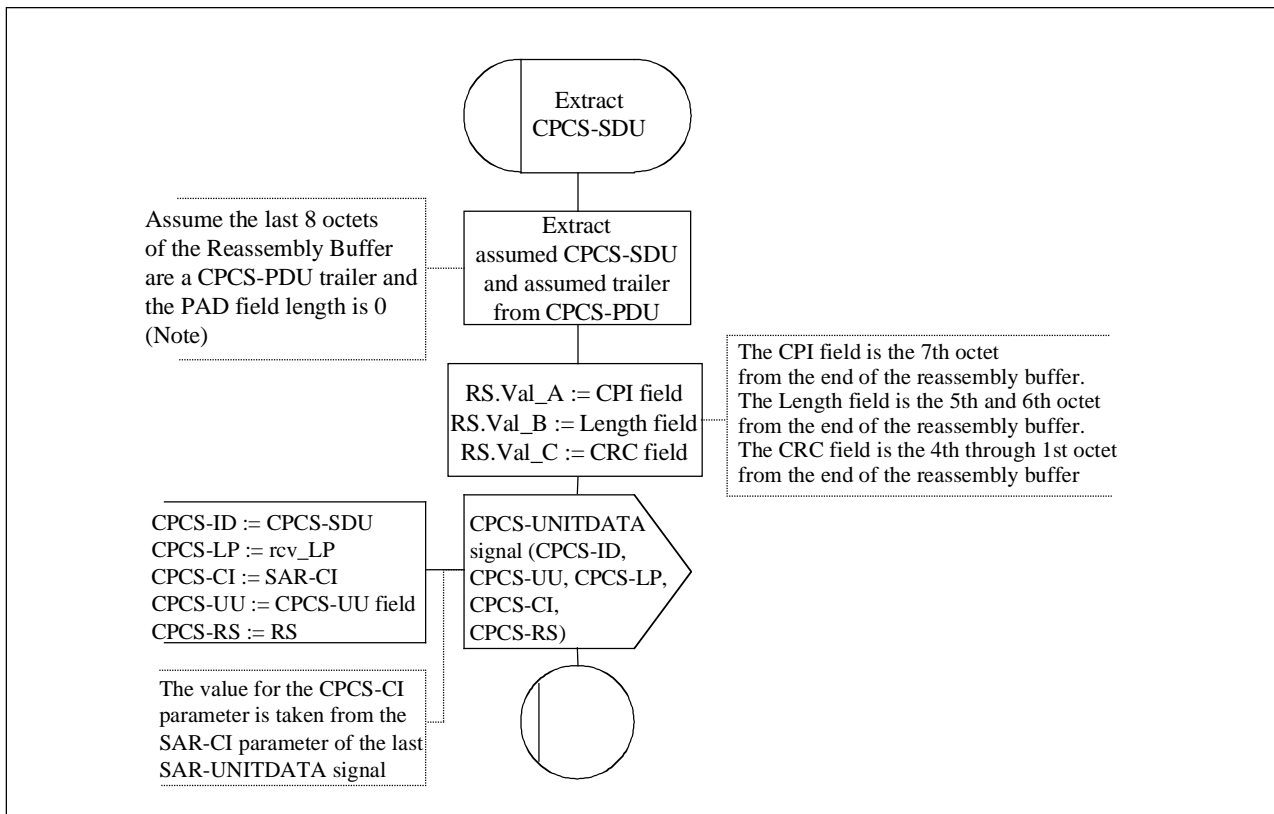

T1307430-95

**Figure E.2/I.363.5 (sheet 6 of 6) – CPCS receiver for the corrupted data delivery option**

## APPENDIX I

### Example CPCS-PDUs for the AAL type 5

The values in the examples are in hexadecimal notation.

a) *Example 1*

40 octets filled with "0"

CPCS-UU field = 0

CPI Field = 0

Length = 40 octets

CRC-32 = 864d7f99

00 00 00 00 00 00 00 00	00 00 00 00 00 00 00 00
00 00 00 00 00 00 00 00	00 00 00 00 00 00 00 00
00 00 00 00 00 00 00 00	00 00 00 28 86 4d 7f 99

b) *Example 2*

40 octets filled with "1"

CPCS-UU field = 0

CPI Field = 0

Length = 40 octets

CRC-32 = c55e457a

ff	ff	ff	ff	ff	ff	ff	ff	ff	ff	ff	ff	ff	ff	ff	ff
ff	ff	ff	ff	ff	ff	ff	ff	ff	ff	ff	ff	ff	ff	ff	ff
ff	ff	ff	ff	ff	ff	ff	ff	00	00	00	28	c5	5e	45	7a

c) *Example 3*

40 octets counting: 1 to 40

CPCS-UU field = 0

CPI Field = 0

Length = 40 octets

CRC-32 = bf671ed0

01	02	03	04	05	06	07	08	09	0a	0b	0c	0d	0e	0f	10
11	12	13	14	15	16	17	18	19	1a	1b	1c	1d	1e	1f	20
21	22	23	24	25	26	27	28	00	00	00	28	bf	67	1e	d0

## APPENDIX II

### Insight into service provided by the procedures of Annex E

Insights into the potential conclusions that may be drawn from the reception status provided by the procedures of Annex E are shown in Table II.1. In this table, each cell contains the possible situations that may cause the simultaneous conditions indicated by the corresponding row and column headings.

In addition, three other types of errors may be detected and reported. These are:

a) **Reassembly buffer overflow**

This is probably due to concatenation of messages. In this case, there is a high probability that no actual CPCS-SDU trailer is in the delivered information; however, for some applications it is likely that recovery of the beginning of the first message could be achieved.

NOTE – This type of error may be avoided with a very good probability if Max\_Corrupted\_SDU\_Deliver\_Length is 2 or 3 times greater than the integral part of Max\_SDU\_Deliver\_Length plus one.

b) **CPI field error**

No real conclusion may be drawn from this error, since only a single CPI value is valid at this time.

c) **Reassembly timer expiry**

This is probably due to loss of the last cells of the message.

**Table II.1/I.363.5 – Potential conclusions that may be drawn from the reception status provided by the procedures of Annex E**

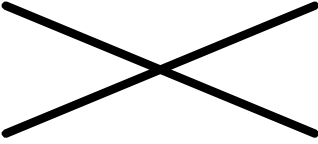
	<b>No CRC error detected</b>	<b>CRC error detected</b>
No Length Error detected		<ul style="list-style-type: none"> <li>• bit error in user data</li> <li>• bit error in CRC field</li> <li>• bit error in PAD field</li> <li>• bit error in CPI field</li> <li>• bit error in CPCS-UU field</li> <li>• bit error in Length field → Since Length error detection is based on a double inequality rather than equality, it may occur that no Length error is detected even if the Length field had been altered.</li> <li>• concatenation of 2 messages → This could happen if a number of cell losses dispersed over two successive messages included the EOM of the first message, making the resultant concatenated CPCS-PDU have the same number of cells as expected for the second message.</li> </ul>
Indicated Length = 0	<ul style="list-style-type: none"> <li>• (residual undetected error case) → CRC is correct coincidentally</li> <li>• ABORT message from user of remote CPCS sender (not possible if sender is not using streaming mode)</li> </ul>	<ul style="list-style-type: none"> <li>• bit error on Length field</li> <li>• Cells missing: the PDU is truncated → If this error is received after a reassembly buffer overflow error occurred, the reassembly of the previously delivered information with the currently delivered CPCS-SDU may allow the recovery of the last transmitted application message. Validity of the last message may be checked while reapplying the CRC calculation over the presumed last message and comparing with the CRC remainder.</li> </ul>
number of octets received < indicated Length	<ul style="list-style-type: none"> <li>• (residual undetected error case) → CRC is correct coincidentally</li> <li>• missing cells</li> </ul>	<ul style="list-style-type: none"> <li>• bit error on Length field</li> <li>• Cells missing: the PDU is truncated → If this error is received after a reassembly buffer overflow error occurred, the reassembly of the previously delivered information with the currently delivered CPCS-SDU may allow the recovery of the last transmitted application message. Validity of the last message may be checked while reapplying the CRC calculation over the presumed last message and comparing with the CRC remainder.</li> </ul>
number of octets received > indicated Length	<ul style="list-style-type: none"> <li>• (residual undetected error case) → CRC is correct coincidentally</li> <li>• cells were misinserted (a very low probability)</li> <li>• concatenation of 2 (or more) messages → Only the last transmitted application message may be entirely recovered. Validity of the last message may be checked while reapplying the CRC calculation over the presumed last message and comparing with the CRC remainder.</li> </ul>	<ul style="list-style-type: none"> <li>• concatenation of 2 (or more) messages → Only the last transmitted application message may be entirely recovered. Validity of the last message may be checked while reapplying the CRC calculation over the presumed last message and comparing with the CRC remainder.</li> <li>• bit error in Length field → Cells were misinserted (a very low probability)</li> </ul>
<p><b>NOTE</b> – This table does not include all error events with low probability, e.g. errors in the ATM cell header.</p>		

## ITU-T RECOMMENDATIONS SERIES

Series A	Organization of the work of the ITU-T
Series B	Means of expression: definitions, symbols, classification
Series C	General telecommunication statistics
Series D	General tariff principles
Series E	Overall network operation, telephone service, service operation and human factors
Series F	Non-telephone telecommunication services
Series G	Transmission systems and media, digital systems and networks
Series H	Audiovisual and multimedia systems
<b>Series I</b>	<b>Integrated services digital network</b>
Series J	Transmission of television, sound programme and other multimedia signals
Series K	Protection against interference
Series L	Construction, installation and protection of cables and other elements of outside plant
Series M	Maintenance: international transmission systems, telephone circuits, telegraphy, facsimile and leased circuits
Series N	Maintenance: international sound programme and television transmission circuits
Series O	Specifications of measuring equipment
Series P	Telephone transmission quality, telephone installations, local line networks
Series Q	Switching and signalling
Series R	Telegraph transmission
Series S	Telegraph services terminal equipment
Series T	Terminals for telematic services
Series U	Telegraph switching
Series V	Data communication over the telephone network
Series X	Data networks and open system communication
Series Z	Programming languages