



INTERNATIONAL TELECOMMUNICATION UNION

ITU-T

TELECOMMUNICATION
STANDARDIZATION SECTOR
OF ITU

H.247

(09/98)

SERIES H: AUDIOVISUAL AND MULTIMEDIA SYSTEMS

Infrastructure of audiovisual services – Communication
procedures

**Multipoint extension for broadband audiovisual
communication systems and terminals**

ITU-T Recommendation H.247

(Previously CCITT Recommendation)

ITU-T H-SERIES RECOMMENDATIONS
AUDIOVISUAL AND MULTIMEDIA SYSTEMS

Characteristics of transmission channels used for other than telephone purposes	H.10–H.19
Use of telephone-type circuits for voice-frequency telegraphy	H.20–H.29
Telephone circuits or cables used for various types of telegraph transmission or simultaneous transmission	H.30–H.39
Telephone-type circuits used for facsimile telegraphy	H.40–H.49
Characteristics of data signals	H.50–H.99
CHARACTERISTICS OF VISUAL TELEPHONE SYSTEMS	H.100–H.199
INFRASTRUCTURE OF AUDIOVISUAL SERVICES	
General	H.200–H.219
Transmission multiplexing and synchronization	H.220–H.229
Systems aspects	H.230–H.239
Communication procedures	H.240–H.259
Coding of moving video	H.260–H.279
Related systems aspects	H.280–H.299
Systems and terminal equipment for audiovisual services	H.300–H.399
Supplementary services for multimedia	H.450–H.499

For further details, please refer to ITU-T List of Recommendations.

ITU-T RECOMMENDATION H.247

MULTIPOINT EXTENSION FOR BROADBAND AUDIOVISUAL COMMUNICATION SYSTEMS AND TERMINALS

Summary

This Recommendation describes and specifies the means by which three or more H.310 audiovisual communication terminals operating in the *native* mode may communicate simultaneously over B-ISDN and/or customer premises ATM network, such communication being designated a "multipoint call". It also covers conference configurations including other H-series terminals.

Source

ITU-T Recommendation H.247 was prepared by ITU-T Study Group 16 (1997-2000) and was approved under the WTSC Resolution No. 1 procedure on the 25th of September 1998.

FOREWORD

ITU (International Telecommunication Union) is the United Nations Specialized Agency in the field of telecommunications. The ITU Telecommunication Standardization Sector (ITU-T) is a permanent organ of the ITU. The ITU-T is responsible for studying technical, operating and tariff questions and issuing Recommendations on them with a view to standardizing telecommunications on a worldwide basis.

The World Telecommunication Standardization Conference (WTSC), which meets every four years, establishes the topics for study by the ITU-T Study Groups which, in their turn, produce Recommendations on these topics.

The approval of Recommendations by the Members of the ITU-T is covered by the procedure laid down in WTSC Resolution No. 1.

In some areas of information technology which fall within ITU-T's purview, the necessary standards are prepared on a collaborative basis with ISO and IEC.

NOTE

In this Recommendation, the expression "Administration" is used for conciseness to indicate both a telecommunication administration and a recognized operating agency.

INTELLECTUAL PROPERTY RIGHTS

The ITU draws attention to the possibility that the practice or implementation of this Recommendation may involve the use of a claimed Intellectual Property Right. The ITU takes no position concerning the evidence, validity or applicability of claimed Intellectual Property Rights, whether asserted by ITU members or others outside of the Recommendation development process.

As of the date of approval of this Recommendation, the ITU had not received notice of intellectual property, protected by patents, which may be required to implement this Recommendation. However, implementors are cautioned that this may not represent the latest information and are therefore strongly urged to consult the TSB patent database.

© ITU 1998

All rights reserved. No part of this publication may be reproduced or utilized in any form or by any means, electronic or mechanical, including photocopying and microfilm, without permission in writing from the ITU.

CONTENTS

	Page
1	Scope 1
2	Normative references..... 3
3	Definitions 4
4	Abbreviations 6
5	System descriptions..... 6
5.1	Multipoint Control Unit 6
5.2	Various VC connection configurations 7
5.2.1	N-point tightly coupled connection case..... 7
5.2.2	A point-to-multipoint without return channels case..... 7
5.2.3	N1-point tightly coupled and n2-point loosely coupled connection case..... 8
5.2.4	A point-to-multipoint with return channels case..... 8
5.3	Initial VC connection directions..... 10
6	Call signalling procedure..... 10
7	MCU functions..... 10
7.1	MC functions..... 10
7.2	MP functions 10
7.2.1	Video switching and mixing 11
7.2.2	Audio switching and mixing 11
7.2.3	Data broadcast procedures – Interactions with T.120 series protocols..... 11
7.3	MR functions..... 11
7.4	Use of the H.245 control channel..... 12
7.4.1	Master/slave determination 12
7.4.2	Mode preferences 12
7.5	Clock synchronization..... 12
7.5.1	General 12
7.5.2	STC generation in MP..... 13
7.5.3	Transmission clock synchronization..... 14
7.6	MCU-MCU interconnections 14
8	Basic communication procedures using H.245 controls 14
8.1	General 14
8.2	Procedure for determining capabilities and selected communication mode 14
8.3	Initialization procedures for establishing communication between standard terminals and an MCU 14
8.3.1	First terminal added to conference..... 14

	Page	
8.3.2	Second terminal added to conference.....	16
8.3.3	Third terminal added to conference	17
8.3.4	Fourth and subsequent calls added to conference	18
8.3.5	Closure of conference	18
8.4	Video processing	18
8.4.1	Video switching	18
8.4.2	Video mixing.....	19
8.4.3	Combination of video switching and mixing.....	19
8.5	Mode switching and data broadcast procedures.....	19
8.5.1	Bit-rate symmetry.....	19
8.5.2	Mode switching for data distribution in multipoint conferences	20
8.6	MCU-MCU interconnections	20
8.7	Exceptional procedures	20
9	Advanced communication procedures using T.120/T.130 controls.....	20
10	Security considerations.....	20
11	Interoperability with other H-series terminals.....	20
11.1	Interoperability with H.320/H.321 terminals	20
Annex A	– Point-to-multipoint audiovisual VC setup and release procedures based on Recommendation Q.2971	20
A.1	Setup of the first party	21
A.2	Adding a party	21
A.3	Dropping a party.....	21
A.4	Information Elements for SETUP message.....	21

Recommendation H.247

MULTIPOINT EXTENSION FOR BROADBAND AUDIOVISUAL COMMUNICATION SYSTEMS AND TERMINALS

(Geneva, 1998)

1 Scope

This Recommendation concerns the system operation for a conference call between three or more H.310 terminals operating in the native mode. It also covers conference configurations including other H-series terminals. It is applicable to a single Multipoint Control Unit (MCU) that multicasts the multiplexed stream without any audio mixing nor video switching, and to a single MCU containing audio mixers and video switches. It is also applicable to an MCU containing video mixers, and to multiple MCUs. Recommendation H.310 provides for communication between two audiovisual terminals connected point-to-point, using the multimedia multiplexer and network adaptation defined in Recommendations H.222.0 and H.222.1. Recommendation H.245 defines a number of Control and Indication signals, including those used in the multipoint communication procedures described in this Recommendation.

Three or more *native* H.310 terminals may be put into communication to form a conference call, by means of one or more MCUs. It should be noted that the physical realization of an MCU may be such that two or more independent conferences are set up within the same unit; logically, however, there is no relationship between these conferences; the text herein refers to an MCU only as a logical entity pertinent to the particular call of concern.

This Recommendation envisions providing:

- a simple protocol stack that can support various applications (e.g. high-quality videoconferencing, distance learning and corporate TV broadcasting);
- a support for various VC connection configurations (e.g. asymmetric bandwidth connection, mixture of bidirectional and multicast connections used in a panel discussion, and unidirectional connection like TV broadcasting);
- a conference configuration including other H-series terminals, i.e. H.320, H.321, H.322, H.323, H.324;
- an option supporting continuous presence video display (video mixing);
- a multicast capability that significantly reduces the network traffic.

For various VC connection configuration examples, the following are within the provision of this Recommendation:

- n-point tightly coupled connection (e.g. multipoint videoconference);
- a point-to-multipoint connection without return channels (e.g. broadcast conference);
- n1-point tightly coupled and n2-point loosely coupled connection (e.g. broadcast panel conference);
- a point-to-multipoint connection with some return channels (e.g. multipoint TV lecture).

Figure 1 shows the general scope of H.247 conference configuration. There are two basic multipoint configurations: MCU-based multipoint vs. decentralized multi-party multipoint. In the interest of traffic load which is significant in the broadband environments, this Recommendation specifies MCU-based multipoint configurations. Decentralized multi-party multipoint is for future study.

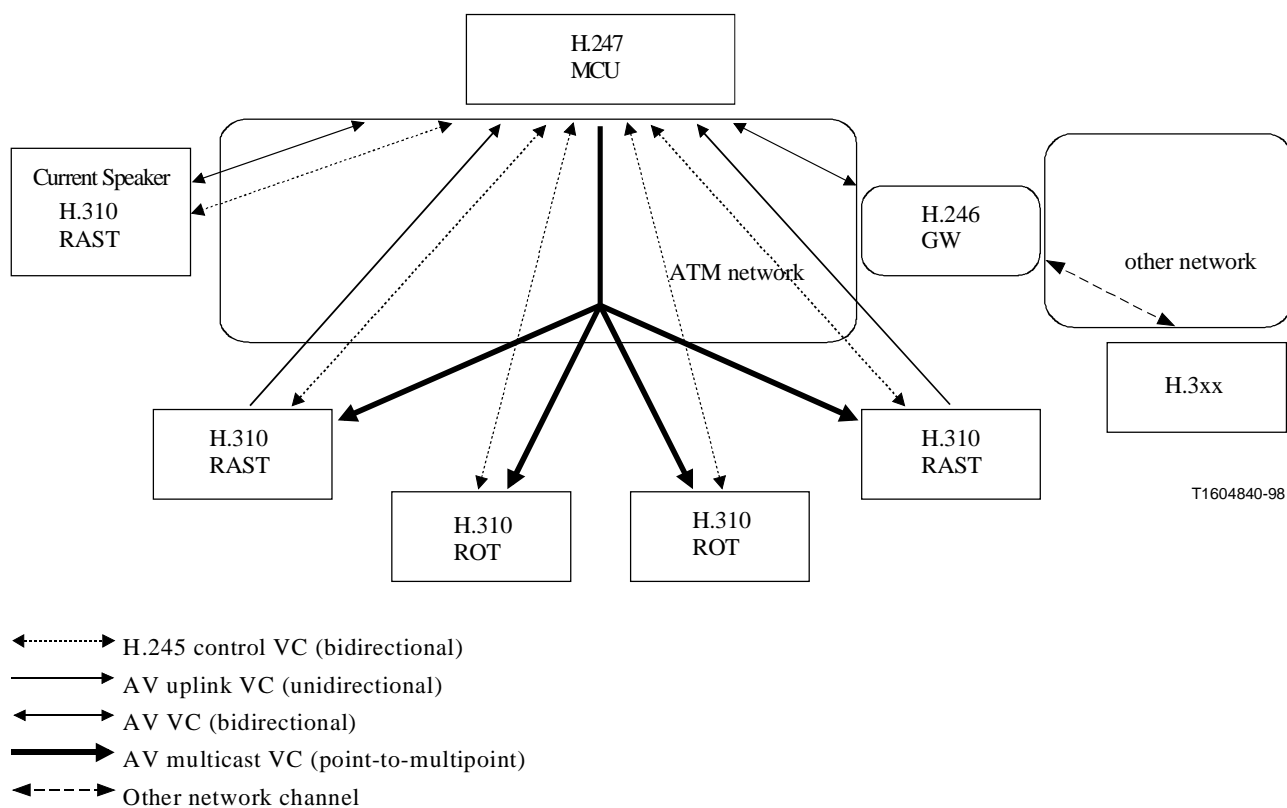

Figure 1/H.247 – General scope of H.247 conference configuration

This Recommendation concerns the flow of signals along ATM virtual channel of B-ISDN or customer premises ATM network. The flow consists of a multiplex of audio, video, control and indication signals, and optional user data as defined in Recommendation H.222.0 which should be handled by the MCU in a way which is satisfactory to the users.

The signal multiplex on each path is fully in accordance with Recommendation H.222.0. Likewise, the basic procedures for initialization and mode switching are fully in accordance with those defined in Recommendations H.310 and H.245 for point-to-point working. However, the composition of the multiplexed signal transmitted by each terminal and by the MCU is determined by terminal procedures and multipoint system procedures, as follows:

- a) terminal procedures are defined in service-specific system Recommendations, such as Recommendation H.310 for audiovisual communications systems and terminal equipment;
- b) multipoint system procedures are defined in this Recommendation, and are not of themselves service-specific;
- c) T.120/T.130: by making use of the T-series Recommendations, MCU and terminal procedures may be greatly enhanced, offering far more sophisticated specific applications to the user. Such enhancement is outside the scope of this Recommendation, although interactions with specific T.120/T.130 methods are described here.

The multipoint conferencing procedure and the MCU for H.320/H.321 interoperation mode of H.310 terminal are defined by Recommendations H.231 and H.243.

2 Normative references

The following ITU-T Recommendations and other references contain provisions which, through reference in this text, constitute provisions of this Recommendation. At the time of publication, the editions indicated were valid. All Recommendations and other references are subject to revision; all users of this Recommendation are therefore encouraged to investigate the possibility of applying the most recent edition of the Recommendations and other references listed below. A list of the currently valid ITU-T Recommendations is regularly published.

- [1] CCITT Recommendation G.711 (1988), *Pulse Code Modulation (PCM) of voice frequencies*.
- [2] ITU-T Recommendation H.221 (1997), *Frame structure for a 64 to 1920 kbit/s channel in audiovisual teleservices*.
- [3] ITU-T Recommendation H.222.0 (1995) | ISO/IEC 13818-1:1996, *Information technology – Generic coding of moving pictures and associated audio information: Systems*.
- [4] ITU-T Recommendation H.222.1 (1996), *Multimedia multiplex and synchronization for audiovisual communication in ATM environments*.
- [5] ITU-T Recommendation H.231 (1997), *Multipoint control units for audiovisual systems using digital channels up to 1920 kbps*.
- [6] ITU-T Recommendation H.235 (1998), *Security and encryption for H-series (H.323 and other H.245 based) multimedia terminals*.
- [7] ITU-T Recommendation H.243 (1997), *Procedures for establishing communication between three or more audiovisual terminals using digital channels up to 1920 kbps*.
- [8] ITU-T Recommendation H.245 (1998), *Control protocol for multimedia communication*.
- [9] ITU-T Recommendation H.261 (1993), *Video codec for audiovisual services at $p \times 64$ kbit/s*.
- [10] ITU-T Recommendation H.262 (1995), | ISO/IEC 13818-2:1996, *Information technology – Generic coding of moving pictures and associated audio information: video*.
- [11] ITU-T Recommendation H.310 (1998), *Broadband audiovisual communication systems and terminals*.
- [12] ITU-T Recommendation H.320 (1997), *Narrow-band ISDN visual telephone systems and terminal equipment*.
- [13] ITU-T Recommendation H.321 (1998), *Adaptation of H.320 visual telephone terminals to B-ISDN environments*.
- [14] ITU-T Recommendation H.332 (1998), *H.323 extended for loosely coupled conferences*.
- [15] ITU-T Recommendation I.363.1 (1996), *B-ISDN ATM Adaptation Layer specification: Type 1 AAL*.
- [16] ITU-T Recommendation I.363.5 (1996), *B-ISDN ATM Adaptation Layer specification: Type 5 AAL*.
- [17] ITU-T Recommendation Q.2931 (1995), *Digital Subscriber Signalling System No. 2 – User-Network Interface (UNI) layer 3 specification for basic call/connection control*.

- [18] ITU-T Recommendation Q.2941.1 (1997), *Digital Subscriber Signalling System No. 2 – Generic identifier transport.*
- [19] ITU-T Recommendation Q.2961.1 (1995), *Digital Subscriber Signalling System No. 2 – Additional traffic parameters: Additional signalling capabilities to support traffic parameters for the tagging option and the sustainable cell rate parameter set.*
- [20] ITU-T Recommendation Q.2961.2 (1997), *Digital Subscriber Signalling System No. 2 – Additional traffic parameters: Support of ATM transfer capability in the broadband bearer capability information element.*
- [21] ITU-T Recommendation Q.2971 (1995), *Digital Subscriber Signalling System No. 2 – User-network interface layer 3 specification for point-to-multipoint call/connection control.*
- [22] ITU-T Recommendation T.120 (1996), *Data protocols for multimedia conferencing.*
- [23] ITU-T Recommendation T.122 (1998), *Multipoint communication service – Service definition.*
- [24] ITU-T Recommendation T.123 (1996), *Network specific data protocol stacks for multimedia conferencing.*
- [25] ITU-T Recommendation T.124 (1998), *Generic Conference Control.*
- [26] ITU-T Recommendation T.125 (1998), *Multipoint communication service protocol specification.*
- [27] ITU-T Recommendation T.130, *Audiovisual control for multimedia conferencing Architecture and overview.*
- [28] ISO/IEC 11172-3:1993, *Information Technology – Coding of moving pictures and associated audio for digital storage media at up to about 1.5 Mbit/s – Part 3: Audio.*
- [29] ISO/IEC 13818-3:1995, *Information Technology – Generic coding of moving pictures and associated audio – Part 3: Audio.*

3 Definitions

In this Recommendation, the word "shall" is used to indicate a mandatory requirement, while the word "should" is used to indicate an option or a suggestion. "May" indicates an optional course of action rather than a recommendation that something take place.

Control and signalling messages are indicated in **bold** face. Referred Recommendation is attached to the message.

3.1 active MC: An MC that has won the master/slave determination procedure and is currently providing the multipoint control function for the conference.

3.2 broadcast conference: A broadcast conference is one in which there is one transmitter of multiplex streams and many receivers. There is no bidirectional transmission of multiplexed streams. Such conferences should be implemented using network transport multicast facilities, if available. Also see Recommendation H.332.

3.3 broadcast panel conference: A broadcast panel conference is a combination of a multipoint conference and a broadcast conference. In this conference, several terminals are engaged in a multipoint conference while many other terminals are only receiving the multiplex streams. There is bidirectional transmission between the terminals in the multipoint portion of the conference and no bidirectional multiplex stream transmission between them and the listening terminals. Also see Recommendation H.332.

- 3.4 control and indication:** End-to-end signalling between terminals, consisting of control, which requires action but no explicit response in the receiver, and indication which contains information but does not require action or response in the receiver.
- 3.5 customer premises ATM network:** An ATM network administered by the user.
- 3.6 endpoint:** A native H.310 terminal, MCU or the gateway to other H-series terminals. An endpoint can call and be called. It generates and/or terminates information streams.
- 3.7 H.245 control channel:** Reliable channel used to carry the H.245 control information messages between two H.247 endpoints.
- 3.8 H.245 session:** The part of the call that begins with the establishment of an H.245 control channel, and ends with the receipt of the H.245 **EndSessionCommand** or termination due to failure.
- 3.9 leaf:** A leaf is one of the destinations of the point-to-multipoint connection.
- 3.10 logical channel:** A logical channel is a unidirectional path or bidirectional path for the transmission of information.
- 3.11 multicast repeater:** A Multicast Repeater (MR) receives unidirectional multiplex stream from a terminal, other MCU or an MP, and multicasts the multiplex stream to other terminals. It may use network multicast (i.e. a point-to-multipoint VC), or may provide TS packet-based copy function. The MR may provide cell-based copy function in a network interface.
- 3.12 multipoint conference:** A multipoint conference is a conference between three or more terminals. The multipoint conference shall always be controlled by an MC. Various multipoint conference types are defined in this Recommendation, but they all require one or more MCs per conference. They may also involve one or more H.231 MCUs on the SCN. A terminal on the ATM network may also participate in an SCN multipoint conference by connecting via a gateway to an SCN MCU. This does not require the use of an MC.
- 3.13 multipoint control unit:** The Multipoint Control Unit (MCU) is an endpoint on B-ISDN or customer premises ATM network which provides the capability for three or more terminals to participate in a multipoint conference. It may also connect two terminals in a point-to-point conference which may later develop into a multipoint conference. The MCU consists of three parts: a mandatory MC and optional MPs and MRs. In the simplest case, an MCU may consist only of an MC and an MR with no MPs.
- 3.14 multipoint controller:** The Multipoint Controller (MC) is an H.247 entity on B-ISDN or customer premises ATM network which provides for the control of three or more terminals participating in a multipoint conference. It may also connect two terminals in a point-to-point conference which may later develop into a multipoint conference. The MC provides for capability negotiation with all terminals to achieve common levels of communications. It may also control conference resources such as who is multicasting the audiovisual stream. The MC does not perform mixing or switching of audio, video and data.
- 3.15 multipoint processor:** The Multipoint Processor (MP) is an H.247 entity on B-ISDN or customer premises ATM network which provides for the centralized processing of audio, video, and/or data streams in a multipoint conference. The MP provides for the mixing, switching, or other processing of multiplexed streams under the control of the MC.
- 3.16 primary terminal:** A terminal which supports the SCM. See Recommendation H.243.
- 3.17 root:** The root is the source of the point-to-multipoint connection.
- 3.18 secondary terminal:** A terminal which does not support the SCM. See Recommendation H.243.

3.19 selected communication mode (SCM): A communication mode which MCU identifies to use in a particular multipoint communication session. See Recommendation H.243.

4 Abbreviations

This Recommendation uses the following abbreviations:

ATM	Asynchronous Transfer Mode
B-HLI	Broadband High-Layer Information
B-ISDN	Broadband Integrated Services Digital Network
B-LLI	Broadband Low-Layer Information
CBR	Constant Bit Rate
MC	Multipoint Controller
MCS	Multipoint Communications System
MCU	Multipoint Control Unit
MP	Multipoint Processor
MPEG	Motion Picture Experts Group
MR	Multicast Repeater
PCR	Program Clock Reference
RAST	Receive-And-Send Terminal
ROT	Receive-Only Terminal
SCM	Selected Communication Mode
SCN	Switched-Circuit Network
SOT	Send-Only Terminal
STC	System Time Clock
TS	Transport Stream
VBR	Variable Bit Rate
VC	Virtual Channel

5 System descriptions

5.1 Multipoint Control Unit

The MCU is an endpoint which provides support for multipoint conferences. The MCU consists of one or more network interfaces, an Multipoint Controller (MC), zero or more Multipoint Processors (MPs) and zero or more Multicast Repeaters (MRs) as shown in Figure 2. The MC provides control functions to support conferences between three or more endpoints in a multipoint conference by terminating and sourcing the call control and H.245 control channels. The MC carries out the capabilities exchange with each endpoint in a multipoint conference. The MP receives multiplexed streams from the endpoints involved in a multipoint conference. The MP demultiplexes the multiplexed streams, processes their elementary streams (i.e. audio, video, data, and so on), and multiplexes the processed elementary streams into re-multiplexed streams. The MR receives unidirectional multiplexed stream from a terminal or an MP, and multicasts them to other terminals.

The MCU uses H.245 messages and procedures to implement features similar to those found in Recommendation H.243. A typical MCU in a broadcast conference application consists of an MC

and an MR. A typical MCU in a tightly coupled conference application consists of an MC and an MP.

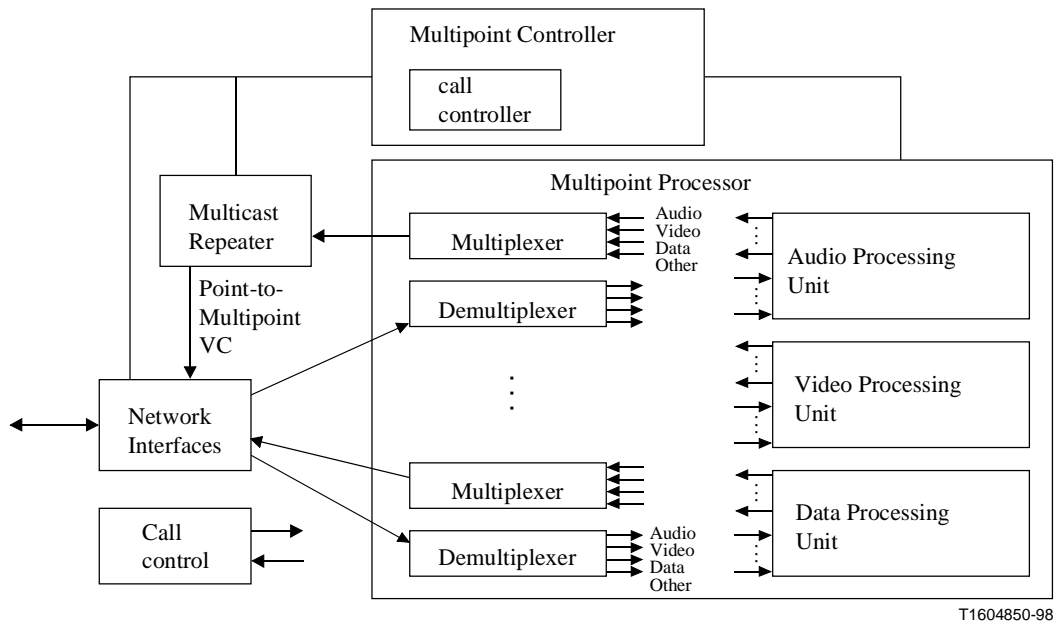

Figure 2/H.247 – Block diagram of a Multipoint Control Unit

5.2 Various VC connection configurations

To capitalize on the point-to-multipoint and multicast communication capabilities of the broadband ATM network, this Recommendation addresses various multipoint configuration as depicted in Figure 3.

5.2.1 N-point tightly coupled connection case

Figure 3 a) shows an MCU-based 3-point tightly coupled connection example. This MCU consists of MC and MP entities without MR entity. The MC has a bidirectional H.245 control connection and a bidirectional audiovisual connection for each terminal. The MP extracts audio elementary stream from the multiplexed streams, and mixes them and encodes the result again. The re-encoded audio elementary stream is multiplexed again with the multiplexed stream that includes switched/mixed video elementary stream.

No special functionality is required for the H.310 RAST terminal to join the H.247 conference. The MCU behaves just as a peer H.310 RAST terminal.

5.2.2 A point-to-multipoint without return channels case

Figure 3 b) shows an MCU-based single-point to 4-point without return channel connection example. This MCU consists of MC and MR entities and no MP. The MC has a bidirectional H.245 control connection for each terminal. H.310 SOT has a unidirectional audiovisual connection to the MR, while the MR multicasts an audiovisual stream to H.310 ROTs. H.310 ROT that wants to receive an audiovisual multicast sets up an H.245 control call to the MCU. The MCU will then add the terminal as one of the leaves of multicast connection.

5.2.3 N1-point tightly coupled and n2-point loosely coupled connection case

Figure 3 c) shows an MCU-based 3-point tightly coupled and 4-point receive-only connection example.

H.310 RAST terminal has bidirectional audiovisual connection to the MCU, while H.310 ROT is on a leaf of the audiovisual point-to-multipoint connection. An H.310 RAST terminal can be on a leaf of the audiovisual point-to-multipoint connection if the current speaker is not on the terminal. The MCU consists of MC, MP and MR. The MC has a bidirectional H.245 control connection for each terminal. The MP extracts audio elementary streams from the multiplexed streams, and mixes them and encodes the result again. The re-encoded audio elementary stream is multiplexed again with the stream that includes switched/mixed video elementary stream. The MR receives re-multiplexed stream from the MP, and multicasts to H.310 ROTs.

5.2.4 A point-to-multipoint with return channels case

Figure 3 d) shows an MCU-based single-point to 4-point with 4 return channel connection example. The MCU consists of MC, MP and MR. The MC has a bidirectional H.245 control connection for each terminal. H.310 RAST terminals except the current speaker's one are on leaves of the audiovisual point-to-multipoint connection. Return channels are unidirectional. The MP may extract audio elementary streams from the multiplexed streams, and mix them and encode the result again. The re-encoded audio elementary stream is multiplexed again with the stream that includes switched/mixed video elementary stream. The MR receives the re-multiplexed stream from the MP, and multicasts it to leaf H.310 terminals.

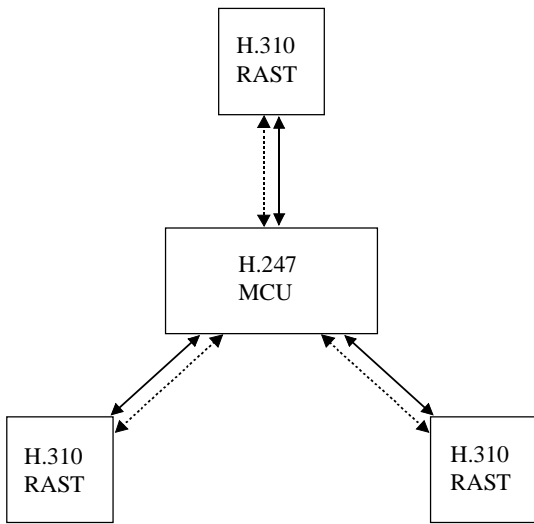

a) 3-point tightly-coupled

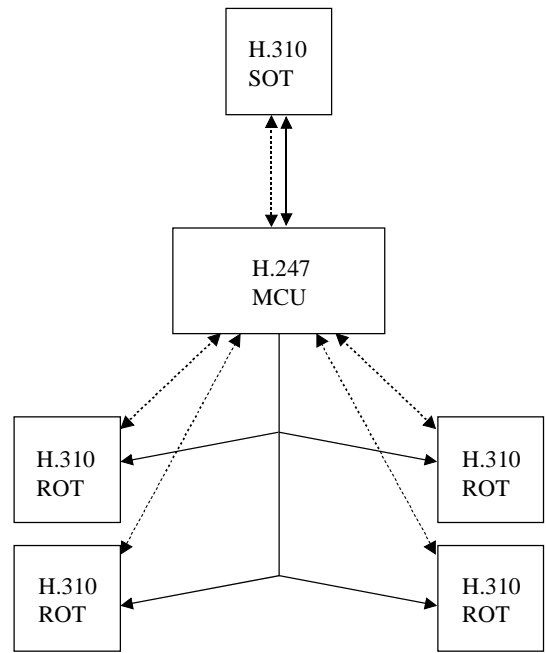

b) a point-to-multipoint without return channels

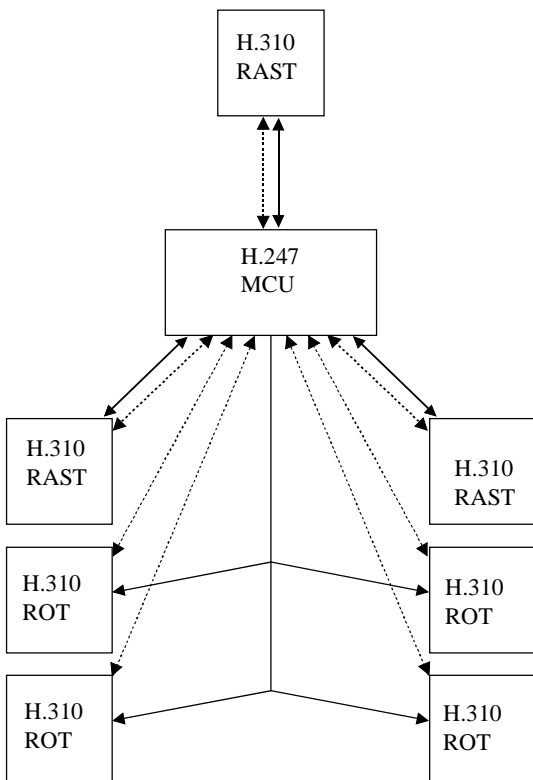

c) 3-point tightly-coupled
4-point loosely-coupled

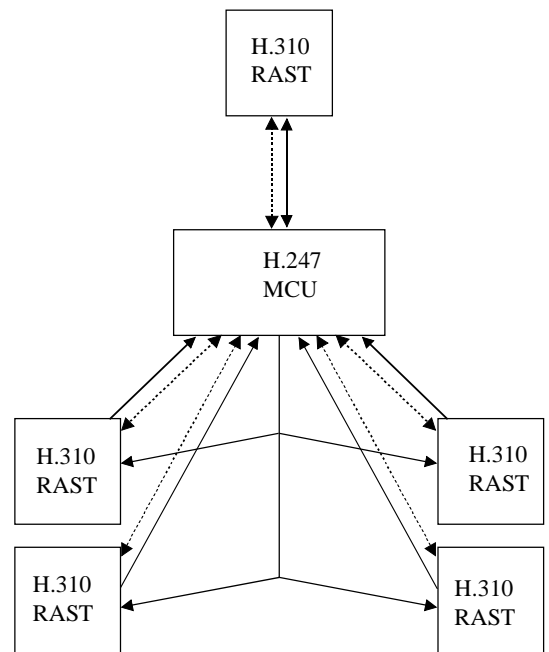

d) a point-to-multipoint with return channels

T1604860-98

- ↔ H.245 control VC (bidirectional)
- ↔ Audiovisual VC (bidirectional)
- Audiovisual VC (unidirectional)
- Audiovisual VC (multicast)

Figure 3/H.247 – Various MCU-based connection configurations

5.3 Initial VC connection directions

In the multipoint communication, there are two types of initial connection setup:

- 1) Leaf terminal initiates an H.245 control call to the MCU ("meet-me").
- 2) The MCU initiates an H.245 control call to each H.310 RAST in order to ask the terminal join the conference or panel ("dial-out").

6 Call signalling procedure

Recommendation Q.2931 [17] and other DSS 2 outband signalling shall be used for initial VC setup, and H.245 control connection shall be used for terminal capability exchanges as defined in Recommendation H.310. The audiovisual call setup can be through a combination of point-to-point and point-to-multipoint signalling procedures. If the audiovisual call is point-to-point, the setup procedure shall be the same as that defined in Annex B/H.310. If the audiovisual call is point-to-multipoint, the setup procedure is specified in Annex A. MCU should use point-to-multipoint VC connections for receive-only terminals. It is noted that ROT terminals are always receive-only. A RAST terminal may identify itself as ROT as described in 7.1.1/H.310.

7 MCU functions

7.1 MC functions

The MC shall provide control functions to support conferences between three or more endpoints in a multipoint conference by terminating and sourcing the call control and H.245 control channels. The MC shall carry out the capabilities exchange with each endpoint in a multipoint conference. The MC shall send a capability set to the endpoints in the conference indicating the operating modes in which they may transmit. The MC may revise the capability set that it sends to the terminals as a result of terminals joining or leaving the conference, or for other reasons.

In this manner, the MC shall determine the Selected Communication Mode (SCM) for the conference. The SCM may be common for all endpoints in the conference. Alternatively, some endpoints may have a different SCM than other endpoints in the conference. The manner in which the MC determines an SCM is not within the scope of this Recommendation. As part of the multipoint conference setup, an endpoint will become connected to an MC on its H.245 control channel.

An MCU always contains an MC. The MCU is callable and the MC processes the H.245 Control channel from all of the endpoints.

When two or more endpoints are in a conference, the endpoints shall use the master/slave resolution procedure of Recommendation H.245 to determine the MC that will control the conference.

After the capability exchange and master/slave determination, the MC may first assign a terminal number to a new endpoint using the H.245 **terminalNumberAssign** message. The MC shall then notify the other endpoints of the new endpoint in the conference using the **terminalJoinedConference**. The new endpoint may request a list of other endpoints in the conference using the **terminalListRequest**.

7.2 MP functions

The MP shall receive multiplexed streams from the endpoints involved in a multipoint conference. The MP shall process these multiplexed streams, and returns the results to the endpoints.

Communications between the MC and the MP are not subject to standardization.

The MP may first extract elementary streams from the multiplexed stream.

When the MP processes video elementary stream, it shall process the video signals as described in 7.2.1. When the MP processes audio stream, it shall process the audio signals as described in 7.2.2. When the MP processes data streams, it shall process data contents as described in 7.2.3.

The MP may provide coding algorithm and format conversion, allowing terminals to participate in a conference at different SCMs.

The MP is not callable, the MCU which it is a part of is callable. The MP shall terminate and source the media channels.

7.2.1 Video switching and mixing

An MP which processes video shall provide either video switching or video mixing. Video switching is the process of selecting the video that the MP outputs to the terminals from one source to another. The criteria used to make the switch may be determined through detection of a change in speaker (sensed by the associated audio level) or through H.245 control. Video mixing is the process of formatting more than one video source into the video stream that the MP outputs to the terminals. An example of video mixing is combining four source pictures into a two-by-two array in the video output picture. The criteria for which sources and how many are mixed are determined by the MC until other controls are defined. Since each link in a multipoint configuration may be operating at different bit rates, MCUs may choose to send H.245 **FlowControlCommand** messages to limit the transmitted bit rates to those which can be sent to receivers.

The use of the T.120/T.130 series protocols for these control functions is for further study.

7.2.2 Audio switching and mixing

An MP which processes audio shall prepare N audio outputs from M audio inputs by switching, mixing, or a combination of these. Audio mixing requires decoding the input audio to linear signals (PCM or analogue), performing a linear combination of the signals, and re-coding the result to the appropriate audio format. The MP may eliminate or attenuate some of the input signals in order to reduce noise and other unwanted signals. Each audio output may have a different mix of input signals to allow private conversations. The voice of the current speaker shall not be returned to its location to avoid the looping. The terminals shall assume that their audio is not present in the audio stream returned to them. In general, the audiovisual signal to the current speaker's terminal cannot be the same as the multicast audiovisual signal.

7.2.3 Data broadcast procedures – Interactions with T.120 series protocols

An MP which processes T.120 data shall be capable of acting as a non-leaf MCS provider and should be capable of acting as the Top MCS Provider. An MP may also process non-standard data, transparent user data, and/or other types of data.

7.3 MR functions

An MR shall receive unidirectional multiplexed stream from a terminal, other MCU or an MP, and multicast them to other terminals. It may use network multicast (i.e. a point-to-multipoint VC), or may provide TS packet-based copy function.

NOTE – In the latter case, MR can be seen as a particular type of MP without audiovisual processing.

The MR may provide cell-based copy function when it receives a multiplexed stream from a terminal or an MCU. It may recover CBR service rate and retransmit with a proper peak rate shaper. Communications between the MP and the MR are not subject to standardization.

7.4 Use of the H.245 control channel

All H.247 terminals and MCUs shall support Recommendation H.245 messages and procedures in the native H.310 communication mode. The exact set of H.245 messages and procedures that are mandated in H.310 terminals, and their usage, are specified in 6.4/H.310.

Each H.245 control channel shall be opened between two H.247 endpoints and maintained during the conference. In the multipoint communication, MCUs may force terminals into a particular common mode of transmission by sending to the terminal a receive capability set listing only the desired mode of transmission. The H.247 terminal shall obey the H.245 **multipointModeCommand** message.

7.4.1 Master/slave determination

The H.245 master/slave determination procedures are used to resolve conflicts between two endpoints which can both be the MC for a conference, or between two endpoints which are attempting to open a bidirectional channel. In this procedure, two endpoints exchange terminal types and random numbers in the H.245 **masterSlaveDetermination** message, to determine the master and slave endpoints. H.247 endpoints shall be capable of operating in both master and slave modes. The endpoints shall set H.245 **terminalType** to the value specified in Table 1 and set H.245 **statusDeterminationNumber** to a random number in the range 0 to $2^{24} - 1$. Only one random number shall be chosen by the endpoint for each call, except in the case of identical random numbers, as described in Recommendation H.245.

Table 1/H.247 – H.247 terminal types for H.245 master/slave determination

Feature set	H.247 entity	
	Terminal	MCU
Entity with No MC	128	NA
Entity contains an MC but no MP	NA	165
Entity contains MC with Data MP	NA	175
Entity contains MC with Data and audio MP	NA	185
Entity contains MC with Data, Audio, and video MP	NA	195

Active MC in a conference shall use a value of 240. An MC that is already acting shall always remain the active MC. Therefore, once an MC has been selected as the active MC in a conference, it shall use the active MC value for all subsequent connections to the conference.

7.4.2 Mode preferences

Receivers may request transmitters to send a particular mode using the H.245 **requestMode** message, which describes the desired mode. Transmitters should act according to the request. An endpoint receiving the H.245 **multipointModeCommand** message from the MC shall then comply with all H.245 **requestMode** commands, if they are within its capability set.

7.5 Clock synchronization

7.5.1 General

There are two independent clock sources which need to be considered in H.247 conference:

- 1) 27 MHz System Time Clock (STC) in each H.310 terminal and MP;
- 2) transmission clock for the multiplexed stream.

H.310 terminals and MP may generate their STCs as follows:

- 1) by a local oscillator (local master);
NOTE – In this case a frame synchronizer for video input or a video camera with clock reference input is necessary.
- 2) by referencing video input (video slave);
- 3) by referencing network clock (network slave);
- 4) by referencing recovered system_clock_frequency of the decoder (receiver slave).

The following are possible to generate transmission clock in each terminal and MCU:

- 1) by referencing common network clock (common network clock);
- 2) by referencing receiver clock (local network clock);
NOTE – Local ATM switch might generate the network clock, not referencing public B-ISDN network clock.
- 3) by a local oscillator (local oscillator);
- 4) by referencing video input (video input).

Figure 4 shows different clock sources in multipoint environment. Each terminal might have different STC, i.e. STCa, STCb, STCc, STCd are independent. STC_{mcu} can be locked to one of STCa, STCb, STCc and STCd, but cannot be locked to all of them. Transmission clocks (TCa, TCb, TCc, TCd and TC_{mcu}) might also be different.

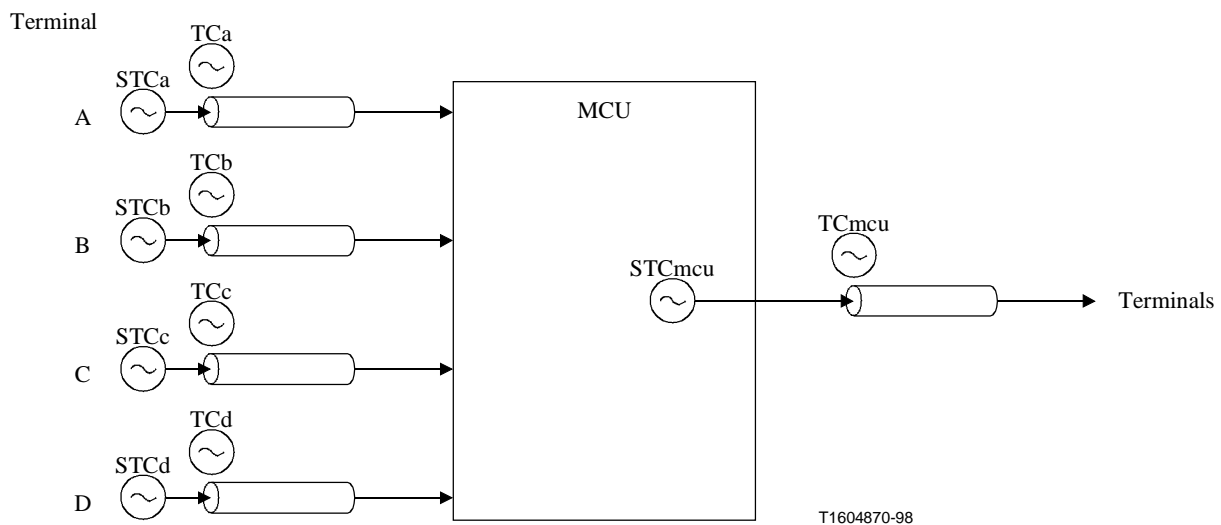

Figure 4/H.247 – Clock sources in multipoint environment

7.5.2 STC generation in MP

STC frequency in an MP shall comply with 2.4.2.1/H.222.0. PCR tolerance due to PCR modification during re-multiplexing in the MP shall comply with 2.4.2.2/H.222.0.

Since there exists the case that STC frequency in each terminal is independent, MP shall accommodate the differences. One possible implementation is to equip a frame synchronizer for video and a sample clock synchronizer for audio. MP may use a recovered STC of a selected peer as a re-multiplexing STC source, only if the stability of the recovered STC satisfies H.222.0 requirements. The ITU-T timing descriptor defined in Recommendation H.222.1 will help the STC recovery process. When the recovered STC is used and video is switched, PCR discontinuity

happens. Within a certain period of time after the PCR discontinuity, frame skip or repeat and/or audio discontinuity may occur by the PCR clock recovery and AV synchronization processing.

7.5.3 Transmission clock synchronization

Common network clock is not always available to all of the terminals. It is especially true in customer premises ATM networks. Thus, H.247 MCU and terminals shall operate in an environment where each terminal has its own transmission clock source. The receiver side of the MCU and each terminal shall recover the transmission clock by the method indicated through AAL parameter IE.

7.6 MCU-MCU interconnections

For future study.

8 Basic communication procedures using H.245 controls

8.1 General

This clause specifies the basic multipoint conference session control for MCU(s) with VC connection configuration specified in Figure 2. Audio is centrally mixed and video are centrally switched or mixed at the MCU. To provide basic conference session controls, the communication procedures use H.245 messages and H.310 video frame synchronous C&I signalling.

8.2 Procedure for determining capabilities and selected communication mode

The MCU shall send appropriate capabilities, according to the type of communication intended. For each conference call a "Selected Communication Mode (SCM)" is identified in the MCU. During the call the MCU strives to maintain this SCM as that transmitted bidirectionally between itself and all terminals, and between itself and other MCUs.

The following are possible methods to determine the SCM:

- 1) the SCM may be fixed as a permanent feature of the MCU as manufactured;
- 2) the MCU may provide for several possible values of SCM, and one of these is specified by the service provider or at the time of booking the call;
- 3) the SCM is selected automatically within the MCU according to the capabilities of the terminals connected; for example, the SCM is set at the value transmitted by the first terminal to access the MCU; or the highest common mode of all primary terminals is selected; or the SCM is set at the value transmitted by the chair-control terminal, if any;
- 4) the SCM is set by using T.120/T.130-series protocols.

To enforce SCM, at the beginning of a conference, MCU sends H.245 **multipointModeCommand** message to all the terminals to command that a terminal in receipt shall comply with all H.245 **requestMode** requests issued by the MCU, if the requested transfer mode is within terminal's capability set.

8.3 Initialization procedures for establishing communication between standard terminals and an MCU

8.3.1 First terminal added to conference

The communication of the first terminal (T1) and MCU follows the following phases:

Phase A1: Call setup (Initial VC setup)

Initial VC is set up between the first terminal and the MCU via Q.2931 **SETUP** message. The exact parameters and Q.2931 and other DSS 2 Information Elements (IEs) used for this phase are described in Annex B/H.310. In this phase, MCU can either identify the type of remote H.310 terminal or infer that the remote terminal is not H.310 terminal type. This is done by using the Broadband Bearer Capability (B-BC), Narrow-band Bearer Capability (N-BC) and other information elements of the Q.2931 **SETUP** message. An H.247 MCU shall set these information elements to the appropriate parameters which indicate the H.310 terminal type. If an H.247 MCU does not receive the N-BC information element from the remote terminal, then the MCU can assume that it is not communicating with an H.320/H.321 terminal.

The initial VC shall have a bit rate of 64 kbit/s at the AAL-SAP, for the transfer of H.245 messages using the separate VC stack described in Annex A/H.310.

Phase A2: Initial communication and capability exchange

After the establishment of the initial VC connection, MCU sends H.245 **multipointConference** and **multipointZeroComm** indications to the first terminal over the initial VC, indicating that a conference call is being set up, that no other terminals are yet connected and the user should wait. Using H.245 procedures, the MCU and the first terminal exchange their capabilities and determine master-slave relationship. Note that the MCU shall always be the Master terminal since it holds the controls of the conference. After the completion of capabilities exchange, MCU can determine "SCM" based on the capabilities exchange or use predetermined "SCM" as described in 8.2.

MCU then sends H.245 **multipointModeCommand** messages to request the first terminal to follow all mode requests from it. Then MCU sends H.245 **RequestMode** command with a list of selected communication modes.

Phase A3: Establishment of audiovisual communication (Additional VC setup and A/V communication)

In this phase, and based on the selected communication mode determined above, MCU shall make a decision as to which party shall set up the additional VC(s) depending on the VC connection configuration. If the connection is point-to-point, either MCU or the terminal can initiate the additional VC. If the connection is point-to-multipoint, MCU shall initiate the additional VC. When the MCU initiates the additional VC(s), the MCU shall firstly indicate the characteristics of the additional VC(s) to the remote end using the H.245 **NewATMVCIIndication** message, and then shall set up the additional VC(s) with the appropriate parameters, such as bit rate and AAL type, for the transfer of the audiovisual and other data between the MCU and the first terminal. When the MCU asks the remote terminal to set up the additional VC(s), the MCU shall send H.245 **NewATMVCCCommand** message.

To accommodate some H.310 terminals that do not support H.245 **NewATMVCCCommand**, the MCU shall accept the additional VC(s) initiated by a terminal. In this case, the MCU can only set up a point-to-point VC connection.

Phase A4: Logical channels setup

After establishment of the additional VC(s), the procedures of Recommendation H.245 shall be used to open the desired video, audio, data, and/or control logical channels using logical channel signalling protocol and bidirectional logical channel signalling protocol defined in Recommendation H.245.

To avoid bad audio, at the discretion of the manufacturer, the MCU should do one of the following for audio:

- send H.245 **logicalChannelInactive** for the audio channel to the terminal;
- send silence or an optional audio-message to the terminal.

The video seen by the first terminal is up to the discretion of the MCU manufacturer.

The data received by the first terminal is up to the discretion of the MCU manufacturer.

8.3.2 Second terminal added to conference

Phase A1: Call setup (Initial VC setup)

Initial VC is set up between MCU and the second terminal (T2) by using the same method as described for the first terminal.

Phase A2: Initial communication and capability exchange

After the establishment of the initial VC, MCU sends H.245 **multipointConference** indication to the second terminal over the initial VC, indicating that a conference call is being set up. Using H.245 procedures, the MCU and the second terminal exchange their capabilities and determine the master-slave relationship. Note that the MCU shall always be the Master terminal since it holds the controls of the conference. After the completion of capability exchange, MCU can determine "SCM" based on the capability exchange or use predetermined "SCM" as described in 8.2.

MCU sends H.245 **multipointModeCommand** messages to request the second terminal to follow all mode requests from it. Then MCU sends H.245 **requestMode** command with the list of selected communication modes.

Phase A3: Establishment of audiovisual communication (Additional VC setup)

In this phase, and based on the communication mode determined above, the MCU shall make a decision as to which party shall set up the additional VC(s) depending on the VC connection configuration. If the connection is point-to-point, either MCU or the terminal can initiate the additional VC. If the connection is point-to-multipoint, MCU shall initiate the additional VC. When the MCU initiates the additional VC(s), the MCU shall firstly indicate the characteristics of the additional VC(s) to the remote end using the H.245 **NewATMVCIndication** message, and then shall set up the additional VC(s) with the appropriate parameters, such as bit rate and AAL type, for the transfer of the audiovisual and other data between the MCU and the second terminal.

If the second terminal is connected to MCU via a point-to-multipoint connection and is not the first "leaf" on the point-to-multipoint connection, then MCU shall send Q.2971 **ADD PARTY** message to the terminal to add the second terminal as the "leaf" to the point-to-multipoint connection.

When the MCU asks the remote terminal to set up the additional VC(s), the MCU shall send H.245 **NewATMVCcommand** message.

To accommodate some H.310 terminals that do not support H.245 **NewATMVCCommand**, the MCU shall accept the additional VC(s) initiated by a terminal. In this case, MCU can only set up a point-to-point VC connection.

Phase A4: Logical channels setup

After establishment of the additional VC(s), the procedures of H.245 shall be used to open the desired video, audio, data, and/or control logical channels using logical channel signalling protocol and bidirectional logical channel signalling protocol defined in Recommendation H.245.

- Audio:
 - Both the (decoded) audio signals are connected to the audio mixer; H.245 **cancelMultipointZeroComm** message is sent to T1;
 - The mixer outputs are sent to T1 and T2 and the mixing algorithm used is up to the MCU manufacturer.
- Video:
 - If video signals are being received from either or both terminals, H.245 **videoFastUpdatePicture** message is sent towards the transmitter(s) of these signals and the next video frame in "Fast update" mode is forwarded to both terminals;
 - If video signals are being received from both terminals, H.245 **videoFastUpdatePicture** message is sent to both terminals. T1's video is forwarded to T2, and T2's video is forwarded to T1;
 - If H.245 **videoIndicateReadyToActivate** indication is received from either or both terminals, this is forwarded.
- Data:
 - If both terminals have an implementation of T.120 protocol, the MCU may connect them to a data conferencing unit;
 - The MCU may defer opening of data channels to a later time, such as when a predetermined number of terminals are present.

8.3.3 Third terminal added to conference

Phase A1: Call setup (Initial VC setup)

Initial VC is set up between MCU and the third terminal by using the same method as described for the first terminal.

Phase A2: Initial communication and capability exchange

After the establishment of the initial VC, MCU sends H.245 **multipointConference** indication to the third terminal over the initial VC, indicating that a conference call is being set up. Using H.245 procedures, the MCU and the third terminal exchange their capabilities and determine the master-slave relationship. Note that the MCU shall always be the Master terminal since it holds the controls of the conference. After the completion of capability exchange, MCU can determine "SCM" based on the capability exchange or use predetermined "SCM" as described in 8.2.

MCU sends H.245 **multipointModeCommand** message to request the third terminal to follow all mode requests from it. Then MCU sends H.245 **requestMode** command with the list of selected communication modes.

Phase A3: Establishment of audiovisual communication

In this phase, and based on the communication mode determined above, the MCU shall make a decision as to which party shall set up the additional VC(s) depending on the VC connection configuration. If the connection is point-to-point, either MCU or the terminal can initiate the additional VC. If the connection is point-to-multipoint, MCU shall initiate the additional VC. When the MCU initiates the additional VC(s), the MCU shall firstly indicate the characteristics of the additional VC(s) to the remote end using the H.245 **NewATMVCIndication** message, and then shall set up the additional VC(s) with the appropriate parameters, such as bit rate and AAL type, for the transfer of the audiovisual and other data between the MCU and the third terminal.

If the third terminal is connected to MCU via a point-to-multipoint connection and is not the first "leaf" on the point-to-multipoint connection, then MCU shall send Q.2971 **ADD PARTY** message to the terminal to add the second terminal as the "leaf" to the point-to-multipoint connection.

When the MCU ask the remote terminal to set up the additional VC(s), the MCU shall send H.245 **NewATMVCcommand** message.

To accommodate some H.310 terminals that do not support H.245 **NewATMVCCommand**, the MCU shall accept the additional VC(s) initiated by a terminal. In this case, MCU can only set up a point-to-point VC connection.

Phase A4: Logical channels setup

After establishment of the additional VC(s), the procedures of H.245 shall be used to open the desired video, audio, data, and/or control logical channels using logical channel signalling protocol and bidirectional logical channel signalling protocol defined in Recommendation H.245.

- Audio:
 - The (decoded) audio signal is connected to the audio mixer;
 - The mixer outputs are sent to all the terminals and the mixing algorithm used is up to the MCU manufacturer.
- Video:
 - If video signals are being received from any one of the terminals T1, T2, and T3, or all of the terminals, video is switched or mixed using the procedures described in 8.4.
- Data:
 - If the new terminal has an implementation of T.120 protocol, the MCU connects it to the data conferencing unit.

8.3.4 Fourth and subsequent calls added to conference

The procedure followed is essentially that of 8.3.3 above.

8.3.5 Closure of conference

If the conference is closed by sequentially dropping terminals, then when only one remains connected it should be sent H.245 **multipointZeroComm** message to allow the user to understand explicitly the reason for loss of video, etc. The terminal dropped follows the following call release procedure to close the connections:

- Logical channels release: In this phase, all logical channels are closed and H.245 **EndSessionCommand** message is transmitted, using the procedures described in Recommendation H.245.
- Virtual Channels release: In this phase, all point-to-point VCs are released using the procedures described in Recommendation Q.2931. For point-to-multipoint connections, a leaf can be dropped from the call by either the MCU or the terminal by sending Q.2971 **DROP PARTY** message.

8.4 Video processing

8.4.1 Video switching

When it is decided within the MCU that terminal A, currently receiving the video signal from terminal B, should instead be sent from terminal C, the following procedure is used:

- a) The MCU shall transmit H.245 **videoFreezePicture** message to terminal A at an appropriate moment, and then switches video Transport Stream packets such that the picture from C is transmitted towards A;
- b) Terminal A receives H.245 **videoFreezePicture** message and should freeze its currently displayed picture; it should ignore subsequent decoded video information, but should continue to track the video elementary stream for the H.310 Video-Frame-Synchronous C&I **videoFreezePictureReleaseControl** signal;
- c) When incoming video to A changes from B-picture to C-picture, video decoding process may be disrupted, and will take a time T to recover, depending on the video bit rate and other factors;
- d) After a time greater than T, the MCU shall transmit H.245 **videoFastUpdatePicture** message to terminal C;
- e) On receipt of H.245 **videoFastUpdatePicture** message, terminal C shall send its next video frame in "fast-update" mode, together with the H.310 Video-Frame-Synchronous C&I **videoFreezePictureReleaseControl** signal;
- f) On receipt of the H.310 **videoFreezePictureReleaseControl** signal, terminal A should revert to display the incoming decoded picture.

8.4.2 Video mixing

The video signal to a terminal can be composed of video signals from other terminals participating in a conference. No particular procedures are defined for the video mixing operation of MP, which is up to the discretion of the manufacturer. The procedures between the terminal and MCU are very similar to the case of point-to-point communication as far as audiovisual transport is concerned.

8.4.3 Combination of video switching and mixing

The procedures defined in 8.4.1 above applies when video switching is involved.

8.5 Mode switching and data broadcast procedures

8.5.1 Bit-rate symmetry

This subclause applies to the case where MCU has no means to transcode the video.

In a point-to-point call, an H.310 terminal can request a new mode of audiovisual communication over the different logical channels using the mode request signalling protocol defined in 8.9/H.245. Then it can switch to a new mode using the logical channel signalling protocol and bidirectional logical channel signalling protocol, and aided by the close logical channel signalling protocol defined in 8.4-8.6/H.245. However, in a multipoint call, there are additional constraints:

- a) because the output packets from the MCU cannot be synchronous with all input packets, there will usually be at least some delay in transmitting a necessary command code;
- b) in a more extreme case the MCU may already be engaged in a capability exchange with another terminal, and so be unable itself to mode switch for some time;
- c) time is needed for the MCU to process capability codes and commands to ensure that the resulting modes are acceptable to all terminals and are imposed in coordination, without corruption of any video being transmitted.

To ensure that an MCU has adequate control, and in particular that it can drive video signal transmission to a common rate, bit-rate changes shall be initiated solely by the MCU. Terminals, after having received H.245 **multipointConference** message from MCU, shall not change the bit rate except in response to such a change incoming from the MCU. MCU may choose to send H.245

FlowControlCommand message to achieve the bit-rate symmetry. This applies to bit rates for audio, data, video, and the transfer rate; audio and video mode changes not involving bit-rate changes may still be initiated by terminals.

8.5.2 Mode switching for data distribution in multipoint conferences

For further study.

8.6 MCU-MCU interconnections

For further study.

8.7 Exceptional procedures

For further study.

9 Advanced communication procedures using T.120/T.130 controls

For further study.

10 Security considerations

Call accept/reject function should be equipped at the MCU. When a closed-user-group conference is going on and an unwanted terminal asks for joining the conference, the MCU should reject the call during call setup. The MCU should monitor the number of terminals in the conference by means of H.245 connections.

11 Interoperability with other H-series terminals

H.247 MCU can interoperate with other H-series terminals. It may use gateway function defined in H.246, interoperation mode for H.320/H.321 terminals, or transcoding techniques. H.247 MCU shall have an ability to invite H.320/H.321 terminal as a secondary terminal.

11.1 Interoperability with H.320/H.321 terminals

The multipoint conferencing procedure and the MCU for H.320/H.321 interoperation mode of H.310 terminal are defined by Recommendations H.231 and H.243.

ANNEX A

Point-to-multipoint audiovisual VC setup and release procedures based on Recommendation Q.2971

This annex describes point-to-multipoint audiovisual VC setup and release procedure based on Recommendation Q.2971 [21]. In Recommendation Q.2971, the "root" is defined as the source of the point-to-multipoint connection, and the "leaf" is defined as one of the destinations of the point-to-multipoint connection. In H.247 connection configuration, the MCU shall be the "root", while other terminals are the "leaf".

A.1 Setup of the first party

The setup of the first party of a point-to-multipoint call is always initiated by the root and follows Q.2931 and other DSS 2 signalling procedures. The Q.2931 **SETUP** message sent by the root shall contain the Endpoint Reference information element and the Broadband Bearer Capability information element with the indication of "point-to-multipoint" in the user plane connection configuration field.

A.2 Adding a party

After the above first party setup has progressed to alerting or active state, additional leaves can be added to the connection by add party requests from the root.

In order to initiate the addition of a party, the root shall send Q.2971 **ADD PARTY** message. The Q.2971 **ADD PARTY** message shall have the same call reference value as specified in the initial setup of the call to which the party is to be added. Multiple add party requests pending at the same time are allowed (e.g. the root does not need to wait for a response related to one add party request before issuing the next one).

A.3 Dropping a party

A leaf can be dropped from the call by either the root or by the leaf, by sending Q.2971 **DROP PARTY** message. Multiple drop party requests pending at the same time are allowed (e.g. the root does not need to wait for a response related to one drop party request before issuing the next one). If, as a result of a drop party procedure, there are no leaf parties remaining in the call, the entire call is released.

A.4 Information Elements for SETUP message

The Information Elements required in the initial VC and point-to-point A/V VC **SETUP** message are specified in Annex B/H.310. Table A.1 shows the Information Elements required in a point-to-multipoint A/V VC setup message.

Table A.1/H.247 – DSS 2 signalling Information Elements

Information Element	Point-to-multipoint A/V VC
Protocol discriminator	M
Call Reference	M
Message type	M
Message length	M
AAL Parameters	M
ATM Traffic descriptor	M
Broadband bearer capability	M
Broadband repeat indicator	O
Broadband low layer information	M
Generic Identifier Transport	M
Broadband High layer information	O
Notification Indicator	O
Called party number	M
Called party subaddress	C
Calling party number	M
Calling party subaddress	C
Connection identifier	O
Extended QoS parameters	O
End to end transit delay	O
QoS parameter	M
Broadband sending complete	C
Transit network selection	O
OAM traffic descriptor	NA
Endpoint reference	M
NA Not Applicable O Optional CM Conditionally Mandatory M Required C Conditional (if appropriate for the network being used)	

Table A.2 summarizes the use of the information elements that are unique to H.247 MCU point-to-multipoint call SETUP. The elements that are not specifically described here are coded in accordance with the requirements of Recommendations Q.2931, Q.2971 and other DSS 2 Recommendations.

**Table A.2/H.247 – DSS 2 Signalling information elements specific
to H.247 MCU point-to-multipoint A/V VC SETUP**

Information element	H.247 point-to-multipoint A/V VC (AAL 1)	H.247 point-to-multipoint A/V VC (AAL 5)
AAL Parameters	AAL Type = AAL 1 Subtype = Video signal transport CBR rate = $n \times 64$ Multiplier = As negotiated by H.245 Source Clock Frequency Recovery = As negotiated by H.245 Error Correction = As negotiated by H.245 SDT Block Size = Implementation specific	AAL Type = AAL 5 Forward CPCS SDU size = $N \times 188$ Backward CPCS SDU size = 0 SSCS Type = Null (Note 1)
ATM Traffic descriptor	Forward PCR = Implementation specific Backward PCR = 0	Forward PCR = Implementation specific Backward PCR = 0
Broadband bearer capability	Bearer Class = BCOB-A Broadband Transfer Capability = CBR Timing Requirements = End-to-end timing required User Plane Connection = Point-to-multipoint	Bearer Class = BCOB-X Broadband Transfer Capability = CBR User Plane Connection = Point-to-multipoint
Broadband low layer information	User Layer 3 = H.310 Terminal type = SOT Terminal capability = AAL 1 Forward multiplexing = TS Backward multiplexing = Null	User Layer 3 = H.310 Terminal type = SOT Terminal capability = AAL 5 Forward multiplexing = TS Backward multiplexing = Null
OAM traffic descriptor	OAM traffic descriptor IE shall not be present since OAM flows are not supported for a point-to-multipoint connection.	OAM traffic descriptor IE shall not be present since OAM flows are not supported for a point-to-multipoint connection.
Endpoint Reference	Endpoint Reference = 15-bit integer (coded in binary) to uniquely identify an endpoint (Note 2)	Endpoint Reference = 15-bit integer (coded in binary) to uniquely identify an endpoint (Note 2)
Generic Identifier Transport	H.310 Correlation ID	H.310 Correlation ID
NOTE 1 – Default value is 376 bytes as per Recommendation H.222.1. N is an integer.		
NOTE 2 – Endpoint Reference = 0 for the first party establishment.		

ITU-T RECOMMENDATIONS SERIES

- Series A Organization of the work of the ITU-T
- Series B Means of expression: definitions, symbols, classification
- Series C General telecommunication statistics
- Series D General tariff principles
- Series E Overall network operation, telephone service, service operation and human factors
- Series F Non-telephone telecommunication services
- Series G Transmission systems and media, digital systems and networks
- Series H Audiovisual and multimedia systems**
- Series I Integrated services digital network
- Series J Transmission of television, sound programme and other multimedia signals
- Series K Protection against interference
- Series L Construction, installation and protection of cables and other elements of outside plant
- Series M TMN and network maintenance: international transmission systems, telephone circuits, telegraphy, facsimile and leased circuits
- Series N Maintenance: international sound programme and television transmission circuits
- Series O Specifications of measuring equipment
- Series P Telephone transmission quality, telephone installations, local line networks
- Series Q Switching and signalling
- Series R Telegraph transmission
- Series S Telegraph services terminal equipment
- Series T Terminals for telematic services
- Series U Telegraph switching
- Series V Data communication over the telephone network
- Series X Data networks and open system communications
- Series Y Global information infrastructure
- Series Z Programming languages