



INTERNATIONAL TELECOMMUNICATION UNION

ITU-T

TELECOMMUNICATION
STANDARDIZATION SECTOR
OF ITU

G.981

(01/94)

**DIGITAL SECTIONS AND DIGITAL
LINE SYSTEMS**

**PDH OPTICAL LINE SYSTEMS
FOR THE LOCAL NETWORK**

ITU-T Recommendation G.981

(Previously "CCITT Recommendation")

FOREWORD

The ITU-T (Telecommunication Standardization Sector) is a permanent organ of the International Telecommunication Union (ITU). The ITU-T is responsible for studying technical, operating and tariff questions and issuing Recommendations on them with a view to standardizing telecommunications on a worldwide basis.

The World Telecommunication Standardization Conference (WTSC), which meets every four years, establishes the topics for study by the ITU-T Study Groups which, in their turn, produce Recommendations on these topics.

The approval of Recommendations by the Members of the ITU-T is covered by the procedure laid down in WTSC Resolution No. 1 (Helsinki, March 1-12, 1993).

ITU-T Recommendation G.981 was prepared by ITU-T Study Group 15 (1993-1996) and was approved under the WTSC Resolution No. 1 procedure on the 20th of January 1994.

NOTE

In this Recommendation, the expression "Administration" is used for conciseness to indicate both a telecommunication administration and a recognized operating agency.

© ITU 1994

All rights reserved. No part of this publication may be reproduced or utilized in any form or by any means, electronic or mechanical, including photocopying and microfilm, without permission in writing from the ITU.

CONTENTS

	<i>Page</i>
1 General	1
1.1 Scope	1
1.2 Objectives	1
1.3 Definitions	1
1.4 Applications and configurations	1
2 Functions	4
3 Optical transmission	4
3.1 Duplex method	4
3.2 Transmission medium	4
3.3 Definition of margins	5
3.4 Transmitter	5
3.5 Receiver	6
3.6 Optical characteristics of one-fibre line terminations	6
3.7 Optical path	6
4 System performance	7
4.1 Error performance	7
4.2 Jitter	7
5 Operation and maintenance	7
6 Power feeding	8
7 Environmental conditions	8
8 Safety considerations	8

PDH OPTICAL LINE SYSTEMS FOR THE LOCAL NETWORK

(Geneva, 1994)

1 General

1.1 Scope

This Recommendation covers digital line systems for the transmission of signals based on the plesiochronous hierarchy on optical fibre cables in the local network and includes systems conveying the following bit rates:

- 1544 kbit/s;
- 2048 kbit/s;
- 34 368 kbit/s.

This Recommendation is applicable together with the relevant Recommendations on digital sections for the respective applications. Those include:

- G.962 for ISDN primary rate access at 2048 kbit/s;
- G.963 for ISDN primary rate access at 1544 kbit/s.

1.2 Objectives

The aim of this Recommendation is to achieve longitudinal compatibility of different digital line systems on elementary cable sections, i.e. the possibility of installing digital line systems, produced by different manufacturers, on the same optical fibre cable.

The systems should:

- be in line with the error performance specified in Recommendations G.821 (local grade) and G.826 and should harmonize with the relevant Recommendations;
- be able to provide access to the majority of customers without the use of regenerators;
- be able to support the relevant maintenance functions;
- comply with various national regulations concerning EMI.

NOTE – The possibility of transverse compatibility is for further study.

1.3 Definitions

For the purpose of this Recommendation, the digital optical line systems can be represented as in Figure 1. The systems have no intermediate regenerators.

1.4 Applications and configurations

The transmission system may be applied for ISDN-primary rate access, leased lines or access to other network capabilities using the bit rates defined in 1.1.

Possible configurations in the access network are shown in Figure 2.

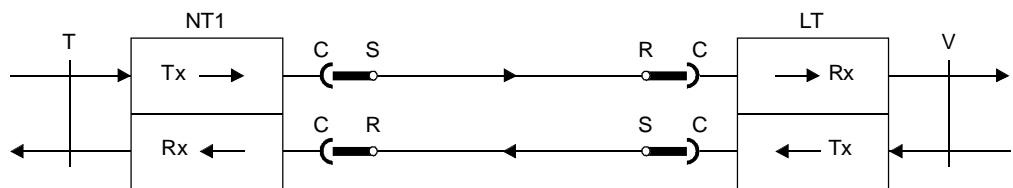

a) Two-fibre system

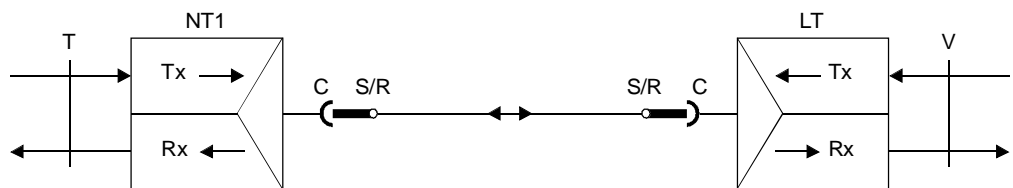

T1512170-92/d01

b) One-fibre system

NT1 Line termination function, customer side (network termination) for ISDN applications: network termination 1 as defined in Recommendation I.411

LT Line termination function, network side for ISDN applications: line termination as defined in Recommendation I.112

C Optical connector at the equipment

T Equipment interface according to Recommendation G.703, customer side for ISDN applications: user network interface as defined in Recommendation I.431

V Equipment interface according to Recommendation G.703, network side for ISDN applications: digital exchange interface as defined in Recommendation Q.512

S Point on the optical fibre just after the transmitter (TX) optical connector (C)

R Point on the optical fibre just before the receiver (RX) optical connector (C)

NOTES

1 Additional connectors at a distribution frame (if used) are considered to be part of fibre link and to be located between points S and R.

2 The coupling function of one-fibre systems which combines the two directions on one fibre, is considered part of the line terminal and not of the optical path.

3 The abbreviations NT1 and LT have been defined elsewhere for ISDN reference configurations. In this Recommendation they are used more generically, i.e. in all applications.

FIGURE 1/G.981

Reference points for system specification

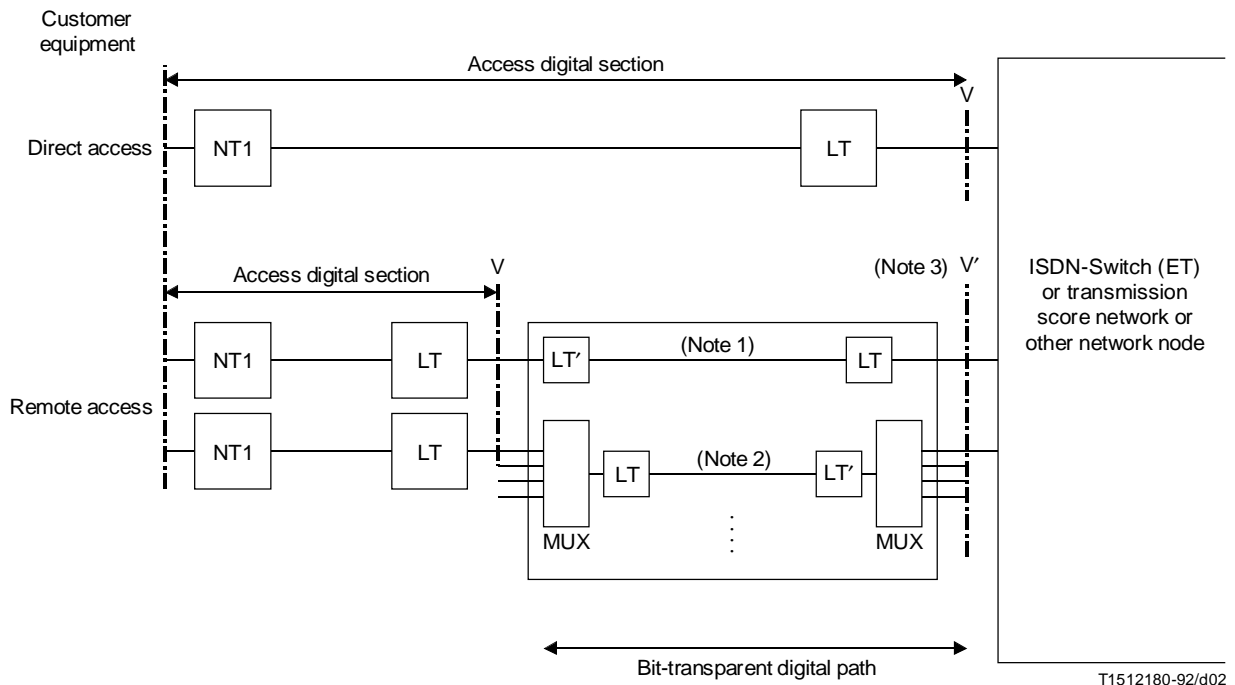

T1512180-92/d02

NOTES

- 1 This application requires line systems LT' of the same bit rate as the NT1/LT line system. The LT' are outside the scope of this Recommendation.
- 2 Multiple applications of digital sections and multiplexers are possible.
- 3 In the case of "remote access" in ISDN the digital access link is terminated at the ET by a V3' interface, which is electrically identical with the V3 reference point as in the case of the direct access.

FIGURE 2/G.981
Examples of configurations of the digital system

2 Functions

The functions are detailed in the relevant Recommendations on digital sections.

Figure 3 gives an overview of the generic functions of the systems.

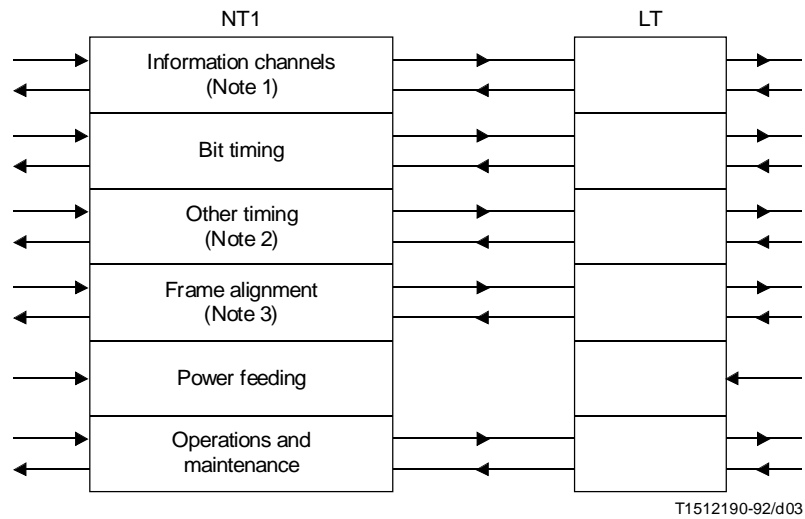

NOTES

- 1 The type of information channels depends on the application. They are defined in the relevant section Recommendation.
- 2 The processing of other timing (e.g. octet timing) is based on bit timing as far as the functions in NT1 and LT are concerned.
- 3 The necessity and details of this function depend on the application and are specified in the appropriate section Recommendation.

FIGURE 3/G.981

Overview of the generic functions of the systems

3 Optical transmission

3.1 Duplex method

The system may use one of the following duplex methods:

- 1) the use of two fibres, one fibre for each direction;
- 2) the use of one fibre for both directions, applying:
 - a) time division to separate the directions (TDM); or
 - b) wavelength division to separate the directions (WDM); or
 - c) subcarrier division to separate the directions (SCDM).

3.2 Transmission medium

Single mode optical fibres conforming to Recommendation G.652 should be used.

NOTE – Some Administrations may use already installed multimode fibres conforming to Recommendation G.651. Performance of such systems is beyond the scope of this Recommendation.

3.3 Definition of margins

For the purposes of this Recommendation, the total system margin is subdivided into two main contributions. The allocation of these margins is shown in Figure 4.

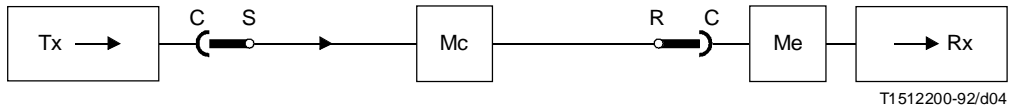

FIGURE 4/G.981
Allocation of margins

3.3.1 Cable margin (Mc)

The cable margin (Mc) covers allowances for:

- i) future modifications to the cable configuration (additional splices, increased cable lengths, etc.);
- ii) fibre cable performance variations due to environmental factors;
- iii) degradation of any connector and optical passive devices between points S and R when provided.

3.3.2 Equipment margin (Me)

The equipment margin (Me) covers allowances for the effect of time and environmental factors on equipment performance (e.g. launched power, receiver sensitivity, equipment connector degradations).

NOTES

1 The design margin, which covers the allowance for the tolerances on the characteristics of the various components of the system, is not considered because worst-case values for such characteristics are reflected in the specifications of clause 4.

2 The system margin is in relation to a BER threshold of 1×10^{-10} even though for practical reasons the measurements of receiver sensitivity may be carried out at other thresholds.

3 The worst-case approach adopted in this Recommendation leaves some additional margin in operating systems which can be considered as an unallocated margin.

3.4 Transmitter

3.4.1 Optical source type

The systems may employ either MLM-lasers (multi-longitudinal mode lasers) or LEDs (light-emitting diodes) as sources. Lasers should not require cooling.

3.4.2 Spectral characteristics

The spectrum and wavelength ranges of the optical source are determined by the characteristics of the optical path and the minimum performance required.

NOTE – For single-mode systems the lower wavelength limit is determined from consideration of cut-off wavelength and possibly dispersion effects, while the upper wavelength limit is due to consideration of attenuation, in particular OH peak related excess losses, and possibly dispersion. The possibility of specifying spectral characteristics of the line interface is for further study.

3.5 Receiver

The optical receiver dynamic range should be sufficient to automatically compensate for equipment production tolerances and the effects of temperatures and ageing, as well as for the total range of optical path attenuation.

The maximum optical path penalty should be ≤ 1 dB. The optical path penalty takes into account the transmitter spectral characteristics and the fibre dispersion.

3.6 Optical characteristics of one-fibre line terminations

For one-fibre systems the optical reflectance of the line termination as seen from reference point S/R should be less than -20 dB.

3.7 Optical path

The optical path specifications serve two purposes:

- to indicate to the network planner the worst-case characteristics the optical path may exhibit to assure satisfactory operation with any equipment;
- to indicate to the equipment designer the worst-case path characteristics the equipment must be able to accommodate.

The overall characteristics of the optical path between reference points S and R are determined by:

- the characteristics of:
 - the cabled optical fibres;
 - splices;
 - connectors;
 - other passive optical devices (if any);
- the cable margin.

Optical fibre cable specifications are given in Recommendation G.652.

Overall optical path specifications between reference points S and R are given in Table 1 together with the following subclauses.

TABLE 1/G.981

Optical path specifications

Nominal bit rate		Allowance between S and R at 1×10^{-10} BER			
		Maximum attenuation at 1310 nm (dB)	Maximum dispersion relevant length (km)	Minimum optical return loss at S (dB)	Maximum propagation delay (μ s)
1544 kbit/s or 2048 kbit/s	Two fibres	24	n.a.	n.a.	n.a.
	One fibre	12	n.a.	20	85
34 368 kbit/s	Two fibres	12	17	n.a.	n.a.
	One fibre	12	17	20	85
n.a. Not applicable					

3.7.1 Attenuation

Attenuation specifications are given in terms of worst-case values, including losses to splices, connectors, any passive optical devices (if used) and the cable margin. The values are given for the reference wavelength of 1310 nm (value for further study). The values of fibre attenuation at other wavelengths may be calculated with the procedure specified in Appendix I/G.652.

3.7.2 Dispersion

The maximum dispersion is determined by the worst-case chromatic dispersion coefficient and the maximum dispersion relevant length.

The worst-case chromatic dispersion coefficient is specified in Recommendation G.652. Table 1 therefore only specifies the maximum dispersion relevant length.

NOTE – The length specification in Table 1 refers to chromatic dispersion only. The network operator may choose to deploy fibres with better than worst-case chromatic dispersion, thus allowing longer spans in terms of real length, if the original system were dispersion limited.

3.7.3 Optical return loss

At the considered bit rates and using LED or MLM lasers this parameter is not expected to be relevant for systems employing one fibre per direction. However it may be relevant for systems employing one fibre for both directions with time or subcarrier division to separate directions.

The optical return loss includes reflections in the optical path between S and R but not at the receiving connector and at the electro-optical receiving device.

4 System performance

4.1 Error performance

The digital line systems described in this Recommendation are required to provide error performance in accordance with the relevant section Recommendations under all specified working conditions.

The transmitter and receiver should be designed so that a $BER \leq 1 \times 10^{-10}$ is obtained when operating over an optical path between points S and R as specified in 3.7 with no external electromagnetic or electrostatic interference.

4.2 Jitter

Jitter is specified in the relevant Recommendations on digital sections.

5 Operation and maintenance

The required minimum operation and maintenance functions are specified in the relevant Recommendations on digital sections.

System specific operation and maintenance functions are for further study.

The necessity and specification of an F interface at the LT (for local supervision, workstation) and/or a Q-interface at the LT (for connection to the Telecommunications Management Network according to Recommendation G.771) is for further study.

6 Power feeding

Both NT1 and LT are fed locally. The details of power feeding should comply with national standards.

Power feeding of NT1 in the application of ISDN primary rate access is defined in Recommendation I.431. Other power requirements are for further study.

7 Environmental conditions

Climatic conditions and electromagnetic compatibility requirements are under study in IEC. Appropriate references include IEC 721-3-1 for climatic conditions and IEC 801-2 and 801-3 for electromagnetic compatibility. Equipment shall meet all specifications when normal operating conditions are fulfilled.

8 Safety considerations

The Recommendations for guidance for the safe use, maintenance and service of line systems on optical fibre cables with operating wavelengths between 400 nm and 3000 nm are to be found in IEC 825-1 and IEC 825-2.