



INTERNATIONAL TELECOMMUNICATION UNION

**ITU-T**

TELECOMMUNICATION  
STANDARDIZATION SECTOR  
OF ITU

**G.974**

(03/93)

**DIGITAL SECTIONS AND DIGITAL  
LINE SYSTEMS**

---

**CHARACTERISTICS OF REGENERATIVE  
OPTICAL FIBRE SUBMARINE CABLE  
SYSTEMS**

**ITU-T Recommendation G.974**

(Previously "CCITT Recommendation")

---

## FOREWORD

The ITU Telecommunication Standardization Sector (ITU-T) is a permanent organ of the International Telecommunication Union. The ITU-T is responsible for studying technical, operating and tariff questions and issuing Recommendations on them with a view to standardizing telecommunications on a worldwide basis.

The World Telecommunication Standardization Conference (WTSC), which meets every four years, established the topics for study by the ITU-T Study Groups which, in their turn, produce Recommendations on these topics.

ITU-T Recommendation G.974 was prepared by the ITU-T Study Group XV (1988-1993) and was approved by the WTSC (Helsinki, March 1-12, 1993).

---

## NOTES

1 As a consequence of a reform process within the International Telecommunication Union (ITU), the CCITT ceased to exist as of 28 February 1993. In its place, the ITU Telecommunication Standardization Sector (ITU-T) was created as of 1 March 1993. Similarly, in this reform process, the CCIR and the IFRB have been replaced by the Radiocommunication Sector.

In order not to delay publication of this Recommendation, no change has been made in the text to references containing the acronyms "CCITT, CCIR, or IFRB" or their associated entities such as Plenary Assembly, Secretariat, etc. Future editions of this Recommendation will contain the proper terminology related to the new ITU structure.

2 In this Recommendation, the expression "Administration" is used for conciseness to indicate both a telecommunication administration and a recognized operating agency.

© ITU 1994

All rights reserved. No part of this publication may be reproduced or utilized in any form or by any means, electronic or mechanical, including photocopying and microfilm, without permission in writing from the ITU.

## CONTENTS

	<i>Page</i>
1 Introduction .....	1
2 Characteristics and performance of the system .....	1
2.1 Characteristics and performance of the digital line sections.....	1
2.2 Characteristics and performance of the optical sections .....	2
2.3 System reliability performance .....	3
3 Characteristics and performance of the terminal equipment .....	3
3.1 General.....	3
3.2 Transmission performance.....	3
3.3 Actions consequent to an alarm .....	4
3.4 Automatic switching .....	4
4 Characteristics and performance of the repeater .....	4
4.1 Characteristics of the signal at the optical interface .....	4
4.2 Jitter performance .....	5
5 Characteristics and performance of the cable.....	5
5.1 Transmission characteristics .....	5
5.2 Mechanical characteristics and resistance to the environment .....	5
5.3 Electrical characteristics .....	6
Annex A – Implementation of regenerative optical fibre submarine cable systems.....	8
A.1 Introduction .....	8
A.2 System configuration .....	8
A.3 Characteristics of the line signal .....	10
A.4 System operation .....	11
A.5 Repeater and branching unit characteristics .....	11
A.6 Manufacturing and installation .....	12
A.7 Maintenance.....	14



## CHARACTERISTICS OF REGENERATIVE OPTICAL FIBRE SUBMARINE CABLE SYSTEMS

(Helsinki, 1993)

### 1 Introduction

This Recommendation is concerned primarily with the system performance and interface requirements of regenerative optical fibre submarine cable systems. The physical implementation of such systems is considered separately in Annex A.

### 2 Characteristics and performance of the system

#### 2.1 Characteristics and performance of the digital line sections

The digital line sections provided by the system should be in accordance with the relevant CCITT Recommendations.

##### 2.1.1 Characteristics of the digital signals at the system interface

The recommended interface bit rates are given in Recommendations G.702, G.703, G.707, etc.

Several interface bit rates may coexist for one single optical fibre submarine cable system.

##### 2.1.2 Overall error performance

The error performance of an optical fibre submarine cable system should conform to Recommendation G.821 for the design life of the system. The relevant parameters are degraded minutes, severely errored seconds, and errored seconds. They are derived from Recommendation G.821 in conjunction with the performance at the 64 kbit/s on a per kilometre basis. Information on the mapping of system performance at the 64 kbit/s level is given in Annex D G.821 (*Blue Book*).

##### 2.1.3 System availability

The unavailable time performance is derived from Recommendation Annex A/G.821 (*Blue Book*), on a per kilometre basis. The DLS allocation is obtained by multiplying the per kilometre allocation by the DLS length.

The system availability depends on the combined aspects of the reliability performance, the maintainability performance and the maintenance support performance of the system equipment, and particularly of the system terminal equipment.

As per Annex A/G.821 (*Blue Book*), a period of unavailable time begins when the bit error ratio (BER) in each second is worse than  $1 \times 10^{-3}$  for a period of ten consecutive seconds. These ten seconds are considered to be unavailable time. The period of unavailable time terminates when the BER in each second is better than  $1 \times 10^{-3}$  for a period of ten consecutive seconds. These ten seconds are considered to be available time.

The unavailability specification applies to unavailable time caused by system component failure, and includes for example laser switching, terminal faults, and supervisory and maintenance operation leading to interruptions of ten seconds or longer. It does not include faults caused by trawlers or other external factors including system power feed reconfiguration time and any period during which the system is depowered for repair. Similarly faults requiring ship intervention are not included in the unavailable time calculation.

## 2.1.4 Jitter performance

The jitter performance of an optical fibre submarine cable system should follow Recommendation G.823 for the system design life. This applies in particular to

- the jitter tolerance, for each digital line section, at the system input interface,
- the maximum output jitter, for each digital line section, at the system output interface,
- the jitter transfer characteristic, for each digital line section, between the input and the output system interface.

## 2.1.5 Performance allocation between portions of the system

The end-to-end performance for a given digital line section (DLS) is obtained by multiplying the specified per km allocation by the DLS length. When it is necessary to allocate performance degradation to various portions in the DLS, an amount corresponding to a fixed length (usually 125 km) is allocated to each station terminal equipment, and the submarine portion is allocated on a per kilometre basis an amount equal to the difference between the DLS specification and the terminal allocation.

## 2.2 Characteristics and performance of the optical sections

### 2.2.1 Optical power budget

The errors created along the submarine portions of systems equipped with regenerators accumulate and thus the overall error performance depends on the error performance of each optical section.

The optical performance of one optical section is characterized by its optical power budget, which is the difference between the mean optical power, expressed in dBm, at the two ends of optical section, as can be obtained taking into account the characteristics of the optical components in the equipment at both ends of the cable section. The optical power budget can be used to calculate the length of elementary cable section which permits fulfilment of the overall error performance requirement for each digital line section in the submarine optical fibre cable system.

Several approaches can be used to calculate the optical power budget. They can be classified into worst case approach, statistical approach, and semi-statistical approach.

The optical power budget should take into account part or all of the following parameters:

- Receiver sensitivity (dBm)  
The mean optical power in the optical signal modulated by a pseudo-random electrical signal with a specified mark density at the input of the optical fibre pigtail of a receiver, below which the receive equipment would exhibit a bit error ratio higher than  $10^{-x}$ .
- Receiver optical overload (dBm)  
The mean optical power in the optical signal modulated by a pseudo-random electrical signal with a specified mark density at the input of the optical fibre pigtail of the receiver, above which the receive equipment would exhibit a bit error ratio higher than  $10^{-x}$ .
- Dynamic range (dB)  
The difference between the receiver optical overload and the receiver sensitivity.
- Mean launched power (dBm):  
The mean optical power in the optical line signal at the output of the optical fibre pigtail of the transmitter.
- The equipment internal loss (dB)
- The optical section loss (dB)

- The system performance penalty (dB)

Taking into account the difference between the performance of an “ideal” regenerator and a “real” regenerator associated with a full cable section. The phenomena to be considered in its value include optical feedback, non-ideal equalisation, partition noise, inter regenerator cross-talk, chromatic dispersion, etc.

- The ageing margin (dB)

Taking into account the variation of the optical component attenuation, including that of fibres, due to ageing during the system design life.

- The repair provision (dB)

Taking into account the possible increase of attenuation of the cabled fibre due to cable repair during the system design life. The value of the repair provision depends on the sea depth. Usually, no repair provision is allocated for the deep sea cable sections. The repair provision for the shallow water sections can be obtained as the product of a repair number, proportional to the cable section length, and of a mean attenuation per repair, equal to the attenuation of two cable joints with the addition of the loss of a length of cable proportional to the sea depth.

- An unassigned margin

A provision for phenomena which can not be precisely foreseen.

- The overload margin

The minimum difference between the receive power and the receiver optical overload.

An important parameter which should be specified to help in system commissioning is the guaranteed margin, that is the minimum margin in the power budget of each particular optical section which should be measured at a specific point in time, e.g., system assembly in factory or on board the cable ship, and which is equal to the sum of ageing, repair, and unassigned margins.

### **2.3 System reliability performance**

The reliability of the submarine portion of an optical fibre submarine cable system is generally characterised by

- the expected number of repairs requiring intervention by a cable ship and due to system component failures during the system design life:

the usual requirement for the system reliability is less than three failures requiring cable ship intervention during the system design life;

- the system design life:

the period of time over which the submarine optical fibre cable system is designed to be operational in conformance with its performance specification. Usually the system design life is a period of 25 years starting at the provisional acceptance date of the system, i.e. the date following installation when the system is compliant with the performance specification.

## **3 Characteristics and performance of the terminal equipment**

### **3.1 General**

The terminal equipment is designed to assemble the tributaries for transmission over the optical fibre submarine cable system, to provide power feeding for the submersible plant and to provide monitoring and maintenance facilities.

### **3.2 Transmission performance**

#### **3.2.1 Characteristics of the digital signal at the system interface**

The digital signal at the system interface should be in accordance with the relevant CCITT Recommendations.

### 3.2.2 Characteristics of the signal at the optical interface

The signal at the optical interface should be in agreement with the power budget of the terminal optical section. In particular, at the time of system installation, certain limits should be respected:

- *Minimum TTE mean input power (dBm)*

The mean optical power in the optical line signal which must be present at the terminal optical input interface so that the optical power budget of the cable section offers the guaranteed margin.

- *Minimum TTE mean output power (dBm)*

The mean optical power in the optical line signal which must be present at the terminal optical output interface so that the optical power budget of the cable section offers the guaranteed margin.

### 3.2.3 Jitter performance

The jitter performance of the TTE of an optical fibre submarine cable system should be in compliance with Recommendation G.823 throughout the system design life. In particular

- the jitter tolerance, for each digital line section, at the system input interface;
- the maximum output jitter, for each digital line section, at the system output interface;
- the jitter transfer characteristic with the terminal in a looped configuration, for each digital line section, between the input and the output system interfaces,

should follow Recommendation G.823.

The jitter performance of the TTE (jitter tolerance, maximum output jitter, jitter transfer characteristics) at the optical interface needs only to be compatible with the individual system specification.

## 3.3 Actions consequent to an alarm

The terminal equipment should detect fault conditions and perform consequent actions as detailed in the relevant CCITT Recommendations (see in particular Table 4/G.921).

## 3.4 Automatic switching

Where automatic switching is used to meet the overall availability requirement,

- the traffic degradation due to switching should be minimised and compatible with the overall system performance,
- indication should be given of the in-service equipment,
- manual override of the automatic switching should be feasible with a minimal degradation of system performance.

The standby equipment is frequently kept operating and monitored like the in-service equipment, except for some specific part, e.g. the optical transmitter.

# 4 Characteristics and performance of the repeater

## 4.1 Characteristics of the signal at the optical interface

The signal at the optical interface should be in agreement with the power budget of the optical section. In particular, at the time of system assembly, certain limits should be respected:

- *Minimum repeater mean input power (dBm)*

The mean optical power in the optical line signal which must be present at the time of link assembly at the repeater optical input interface so that the optical power budget of the cable section offers the guaranteed margin.



- *Minimum repeater mean output power (dBm)*

The mean optical power in the optical line signal which must be present at the time of link assembly at the repeater optical output interface so that the optical power budget of the cable section offers the guaranteed margin.

For integrated systems, similar parameters should be specified as part of the integration specification at the integration line optical interface.

## **4.2 Jitter performance**

The jitter performance of the repeater (jitter tolerance, maximum output jitter, jitter transfer characteristics) at the optical interface need only to be compatible with the system specification.

For integrated systems, the same parameters, the output repeater jitter spectral density and the alignment jitter should be specified as part of the integration specification at the integration line optical interface.

# **5 Characteristics and performance of the cable**

## **5.1 Transmission characteristics**

Generally, the transmission characteristics of the fibres before cabling (installation in the cable) will be similar to, or the same as, those specified in Recommendations G.652, G.653 or G.654. Types of fibre are chosen to optimise the system overall cost and performance.

The transmission characteristics of the fibres installed in an elementary cable section should be within a specified limit of variation from the characteristics of the fibre before cabling; in particular the design of the cable, cable joints and fibre should be such that fibre bending and microbending create negligible attenuation increase. This is to be taken into account for determining the minimum fibre bending radius in the cable and in the equipment (optical cable joints, termination, repeaters, etc).

The fibre attenuation and chromatic dispersion should remain stable within specified limits for the system design life; in particular the design of the cable should minimize to acceptable levels both hydrogen penetration from outside and hydrogen generation within the cable, even after a cable break at the depth of utilisation; the sensitivity of optical fibre to gamma radiation should also be taken into account.

## **5.2 Mechanical characteristics and resistance to the environment**

### **5.2.1 Fibre protection by the cable structure**

The fibre survivability is governed by the propagation of flaws inside the structure of glass. It depends on the initial mechanical status of the fibre prior to cabling, dependant on the physical structure of the fibre (type of coating, internal stress), on the environmental condition during the fibre production, and on the level of screen test applied to the fibre after fibre drawing. It also depends on fibre environment in the cable, and on the cumulative effect of stress applied to the fibre during its life.

The strength of the cable structure together with that of the fibre determine the overall cable mechanical behaviour. They should be designed so as to guarantee the system design life, taking into account the cumulative effect of load applied to the cable during laying, recovery and repair, as well as any permanent load or residual elongation applied to the installed cable.

Two generic types of cable structure are commonly used to protect the optical fibres:

- the tight cable structure, where the fibres are strongly maintained in the cable, so that the fibre elongation is essentially equal to that of the cable,
- the loose cable structure, where the fibres are free to move inside the cable, so that the fibre elongation is lower than that of the cable, staying zero until the cable elongation reaches a given value.

Moreover, the cable should protect the fibre against water, humidity and external pressure, and limit the longitudinal water penetration after a cable break at the depth of utilisation.

### **5.2.2 Fibre mechanical performance**

The fibre mechanical performance is largely dependant on the application of a proof test to the whole length of fibre. The optical fibre proof test is characterized by the load applied to the fibre or the fibre elongation, and the time of application. The level of the proof test should be determined as a function of the cable structure. Fibre splices should be similarly proof tested.

The mechanical strength of the fibre and splices is to be taken into account for determining the minimum bending radius of the fibre in the cable and in the equipment (repeaters, branching units, cable jointing boxes or cable terminations).

### **5.2.3 Cable mechanical performance**

The cable, with the cable jointing boxes, the cable couplers, and the cable transitions, should be handled with safety by cablesheeps during laying and repair operation; it should withstand multiple passages over the bow of a cable ship.

The cable should be repairable, and the time to make a cable joint on board during a repair in good working conditions should be reasonably short.

When the cable is hooked by a grapnel, an anchor or a fishing tool, it usually breaks for a load approximately equal to a fraction (depending on the cable type and the grapnel characteristics) of the breaking load in straight line conditions; there is then a risk of reduction of the fibre and cable lifetime and reliability in the vicinity of the breaking point, due in particular to the stress applied to the fibre or to water penetration; the damaged portion of cable should be replaced; its length should stay within a specified value.

Several parameters are defined in Recommendation G.972 to characterize the cable mechanical characteristics and the ability of the cable to be installed, recovered and repaired, and to be used as guidance for cable handling:

- the cable breaking load, measured during qualification test;
- the fibre-breaking cable load, measured during qualification test;
- the transitory cable load, which could be accidentally encountered, particularly during recovery operations;
- the operational cable load, which could be encountered during repairs;
- the permanent cable elongation, which characterizes the status of cable after lay,
- the minimum cable bending radius, which is a guidance for cable handling.

### **5.2.4 Cable protection**

The optical fibre submarine cable should be provided with protection against the environmental hazards at its depth of utilisation: protection against marine life, fishbite and abrasion, and armoury against aggression and ship activities. Different types of protected cable are defined in Recommendation G.972, in particular

- the single armoured cable, which generally is used down to approximately 700 meters;
- the double armoured cable, which is generally used down to approximately 400 meters.
- the rock armoured cable, which is generally used down to approximately 200 meters.

The applicable water depths are not limited to the above examples.

Optical fibre land cable should protect the system and the personnel against electrical discharges, industrial interference and lightning. Two types of protected land cable are commonly used:

- the armoured land cable, with an armour to be maintained at earth potential, and which is suitable to be directly buried;
- the duct shielded cable, with a circumferential safety shield (which may be the fishbite protection shield), and which is suitable to be pulled into ducts.

## **5.3 Electrical characteristics**

The cable should enable remote power feeding of repeaters or branching units, and include a power conductor with a low linear resistance, and an insulator with a high voltage insulation capacity.

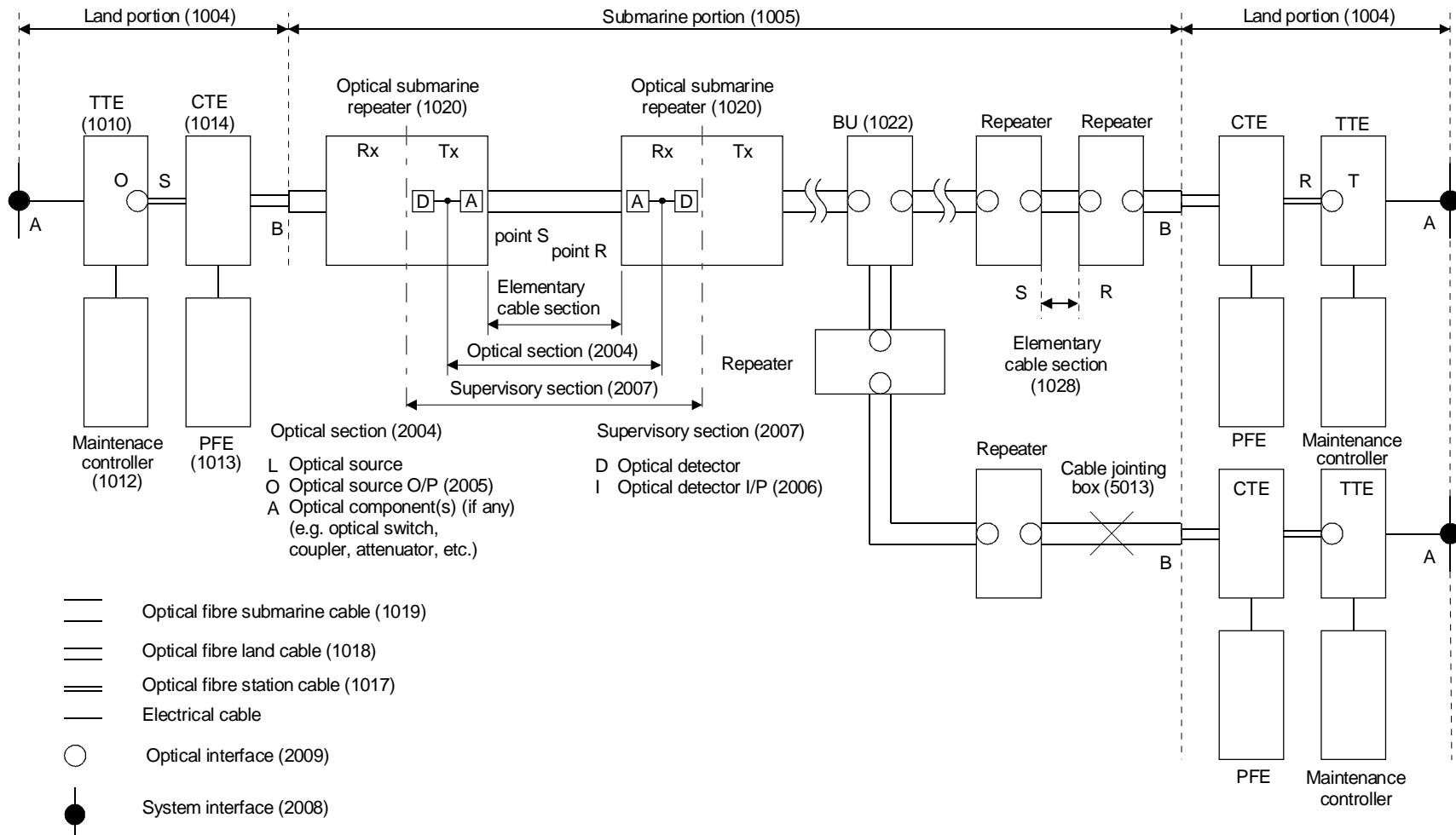

T1507470-92/d01

NOTES

- |   |  |   |   |
|---|--|---|---|
| 1 | A denotes system interface (2008).               | 4 | B-B represents submarine portion (1005).            |
| 2 | B denotes landing points or beach joints (1006). | 5 | X denotes cable jointing box (5013).                |
| 3 | A-B represents land portion (1004).              | 6 | Numbers in brackets relate to Recommendation G.972. |

FIGURE 1/G.974

Example of regenerative optical fibre submarine cable system

## **Annex A**

### **Implementation of regenerative optical fibre submarine cable systems**

(This annex forms an integral part of this Recommendation)

#### **A.1 Introduction**

This annex outlines various aspects of optical fibre submarine cable system practice as commonly employed on regenerative systems. Typical system parameters are illustrated in Table A.1.

The information provided in this Annex is intended as a guide to current practice and is not intended as a recommendation relating to existing or future systems.

#### **A.2 System configuration**

##### **A.2.1 Constituents of an optical fibre submarine cable system**

The purpose of an optical fibre submarine cable system is to establish transmission links between two or more terminal stations. Where only two terminal stations are connected by the cable system then it may be termed an optical fibre submarine cable link. In the other case it may be termed an optical fibre submarine cable network.

Figure 1 shows the basic concept of optical fibre submarine cable systems and boundaries. Optical submarine repeaters and/or optical submarine branching units could be included depending on each system requirement.

In Figure 1, A denotes the system interfaces at the terminal station (where the system can be interfaced to terrestrial digital links or to other submarine cable systems), and B denotes beach joints or landing points. Letters in brackets in the following sections refer to the above figure.

An optical fibre submarine cable system consists of

- a land portion, between the system interface in the terminal station (A) and the beach joint or landing point (B), which includes the optical fibre land cable, land joints, and the system terminal equipment,
- a submarine portion on the sea bed, between the beach joints or landing points (B), which includes the optical fibre submarine cable and where necessary submarine equipment, i.e. optical submarine repeater(s), branching unit(s) and cable jointing box(es).

The cable contains one or more optical fibre pairs (an optical fibre pair is used to establish transmission in both directions).

The optical fibre submarine cable is protected where appropriate: there are several different types of cable characterized by their mechanical structure, such as lightweight cable, lightweight protected cable, light armoured cable, single armoured cable, double armoured cable, and rock armoured cable.

The optical fibre land cable also requires protection. In particular, the optical fibre land cable carries the repeater power feeding current and in these conditions a high potential difference may exist between the cable conductor and the ground, so that personnel protection is necessary.

The optical submarine repeaters include regenerators which are designed to accept an incoming optical signal constrained within certain limits and to regenerate it so that the optical output signal is constrained within certain limits. The repeaters also include units to provide supervisory, protection and power feeding functions. These circuits constitute the repeater optoelectronic unit and are contained within the watertight and pressure-resistant repeater housing.

An optical submarine branching unit (BU) is inserted into the submarine portion of an optical fibre submarine cable network where it is necessary to interconnect more than two cable sections. According to the network requirement this equipment may include some or all of the following subassemblies:

- direct fibre connection;
- fibre switching unit;
- optical regenerators for each fibre; and
- power feeding path switching unit.

Moreover, the BU can provide for signal interchange between optical signal paths, it is then termed an undersea branching multiplexer (UBM).

### **A.2.2 Transmission configuration**

The transmission configuration characterizes the flow of information between the terminal stations across the optical fibre submarine cable system.

An optical fibre cable section may contain a number of optical fibre pairs, and an optical fibre pair may support a number of digital line sections. The number of digital line sections carried by an optical fibre cable section is given by the product of these two numbers.

The digital line sections supported by the same optical fibre pair follow the fibre pair across the repeaters and the branching units. They may be separated between different fibre pairs when crossing an undersea branching multiplexer.

### **A.2.3 Power feeding configuration**

#### **A.2.3.1 General**

The power feeding configuration characterizes the flow of the power feeding current between the terminal stations across the optical fibre submarine cable system.

#### **A.2.3.2 Optical fibre submarine cable link**

In an optical fibre submarine cable link, the current flows from one PFE to the opposite PFE along the power conductor of the optical fibre submarine cable, the return path being established through the sea via power feed earths provided at both ends.

#### **A.2.3.3 Optical fibre submarine cable network**

In an optical fibre submarine cable network, a main power feeding path is similarly established between two main power feeding stations through the power feeding conductors of serially connected optical fibre cable sections. The branches which are not part of the main power feeding path are powered when necessary through the power conductor of the submarine optical cable, between the PFE of their terminal station and the branching unit, the return path being established through the sea via a power feed earth at the terminal station and a branching unit sea electrode. Power path switching in the BU enables this configuration to be changed, particularly under fault conditions.

To avoid corrosion, the direction of the power feeding current is such that the branching unit sea electrode stays cathodic. For some submarine optical fibre cable network configurations, to keep this condition, it may be necessary to change the direction of the power feeding current when changing the power feeding configuration. It is then necessary to use “bipolar” repeaters, which can be powered in either direction.

#### **A.2.3.4 PFE mutual protection**

In some situations, the PFE installed at one end of a link is able to provide in an emergency situation the whole of the power necessary for a given link, when in normal operating condition that total power is shared between the power feeding equipment installed at both ends of the link.

This facility is used in case of a PFE fault, to increase the system availability; it is also used in case of a cable shunt fault, to maintain traffic and/or to help in fault localisation.

#### **A.2.4 Supervisory and remote maintenance of the system**

Supervisory and remote maintenance equipment located in the terminal, in association with the repeater (or BU) supervisory unit, normally provides for fault localisation, repeater performance monitoring and remote controlled redundancy switching.

The supervisory facilities commonly include one or more of the following:

- provision, on an in-service basis, of sufficient information to enable preventive maintenance, particularly if switchable redundancy is provided.
- provision for further out-of-service fault location or system monitoring through loopback remotely controlled from appropriate terminals.
- indication of approaching failure of the in service equipment, so that preventive action may be undertaken or planned.
- the means to locate hard faults and intermittent faults of duration and frequency that cause the system to fail to meet the performance requirement.

In principle the supervisory system enables fault localisation to within one supervisory section. Other means, such as optical reflectometry and electrical measurement using equipment installed in the terminal stations or on board the cable ship may permit the accuracy of fault localisation to be increased.

Supervision of the system may be facilitated by computerized equipment located at one or both ends.

#### **A.2.5 System integration**

A submarine optical fibre cable link or network may be constructed using two or more submarine optical fibre systems (i.e. sets of equipment: cable, repeater, terminal equipment, BU, etc.) designed independently by different suppliers.

To integrate the submarine optical fibre network it is necessary to ensure the compatibility of these designs. This is the purpose of the integration specification.

### **A.3 Characteristics of the line signal**

#### **A.3.1 Structure of the line signal**

The line frame and the line bit rate result from the multiplexing and coding operations performed by the TTE, taking into account the inclusion of the service and supervisory channels.

The line code is chosen so as to suit the characteristics of the submarine portion. It can be used for such purposes as adapting the frequency spectrum of the optical line signal at the optical interface, and monitoring the line bit error rate at the repeaters or in the receive transmission terminal. Violations of the line code may be used for supervisory purposes (system monitoring and/or transmission of supervisory information).

#### **A.3.2 Line error ratio**

The submarine portion performance of systems equipped with regenerators can be adequately measured in terms of the line error ratio, which is the error ratio at a given location in the optical fibre submarine cable system.

Numerical values of the line error ratio are expressed in the form  $n \times 10^{-p}$  where p is an integer.

Practically, the submarine portion is characterized by the apparent line error ratio, which is the value processed from the line error count provided by the supervisory equipment of the repeaters. Generally, the supervisory equipment detects violations of the line code. The apparent line error ratio is directly calculated from the result of this observation. A more accurate value, the actual line error ratio, can be obtained by eliminating deliberate violations of the line code from the calculation.

## **A.4 System operation**

### **A.4.1 Terminal-to-terminal communication**

Generally, at least two service channels are established between two terminal stations: one through the optical fibre submarine cable system for the purpose of operating and maintaining the system, the other through external means for the purpose of maintaining the communication between the two terminal stations in case of system fault.

In particular, a service channel is normally provided to permit transmission of terminal-to-terminal messages between the supervisory equipment of corresponding terminal stations, to provide information on the status of the system and of the digital line sections, and on the ongoing supervisory activity so as to help in overall system monitoring, and in supervisory or fault location.

At least one order wire channel is established between terminal stations exchanging traffic for communication between the staff of the terminal stations.

### **A.4.2 Function and characteristics of the power feeding equipment (PFE)**

#### **A.4.2.1 PFE normal operating condition**

The PFE provides, through the cable power conductor with return through the sea, a stabilized electric current to power the electrical circuits of the optical submarine repeater(s) and/or optical submarine branching unit(s). This current is generally adjustable and is a slightly decreasing function of the PFE resistive load.

The variations in time of the PFE current, which may be caused by ambient temperature changes within a specified range, variations and transient in the power source voltage, or redundancy switching in the PFE, are maintained between specific limits. The PFE current stability is defined so as to meet the overall stability requirement of the optical fibre submarine cable system. The PFE current stability is usually expressed as a percentage of the PFE nominal current.

The PFE output voltage is automatically adjusted to maintain the PFE current constant in the presence of naturally induced voltages. It is usually considered that these naturally induced voltages which accumulate along a link may reach a value of 0.3 V/km (East-West) and that they vary slowly with time (less than 10 V/s).

#### **A.4.2.2 System protection**

The PFE is normally equipped with facilities designed to protect the PFE itself and the submarine portion from excessive current or excessive voltage in case of electrical fault in the PFE itself or anywhere in the system.

In particular, a PFE earth protection is provided to automatically route the power feeding current to the station earth if the system power feed electrode becomes disconnected, or changes to an excessive potential difference from the station earth. The operation of this device is designed to avoid interruption of the optical fibre submarine cable system and to prevent a rise in the power equipment earth potential sufficient to damage the equipment or endanger personnel.

#### **A.4.2.3 PFE personnel protection**

PFE personnel protection is provided to prevent personnel from gaining access to dangerous potentials whether generated at the near end or at the far end of the optical fibre submarine cable system. The protection equipment includes in particular interlocks at the cable terminating equipment, emergency shut-down at the PFE, and earthing devices enabling the cable power conductor to be discharged to earth before handling.

## **A.5 Repeater and branching unit characteristics**

### **A.5.1 General**

The optical submarine repeaters and branching units are capable of being operated in accordance with the system performance recommendations during the system design life and at the sea depth environment conditions (temperature, pressure, etc.).

The optical submarine repeaters and branching units are designed to be capable of being handled, i.e. laid, recovered and relayed, without impairment of the performance of the cable, cable jointing boxes, repeaters, branching units, and cable terminations, provided that handling specifications are respected.

The optical submarine repeaters and branching units are designed to be transported and stored under specified temperature condition without affecting the system design life, provided that storage and transport specifications are respected.

The optical submarine repeaters and branching units are capable of being operated on board a cableship during laying and repair operations without affecting the system design life.

The size of the optical submarine repeater is such that it can be handled by appropriate cableship equipment.

The repeater optical input interface (point R) on each incoming fibre is defined where the repeater fibre is spliced to the cable fibre.

The repeater optical output interface (point S) on each outgoing fibre is defined where the repeater fibre is spliced to the cable fibre.

### **A.5.2 Repeater (or BU) constituents**

The main repeater (or BU) constituents are

- *The repeater (or BU) housing*

The mechanical piecepart, containing the optoelectronic unit. The housing is designed to provide resistance to the sea depth pressure, watertightness, high mechanical strength, electrical and optical connection to the cable sections on each side of the repeater (or BU), high voltage insulation and low thermal impedance between the repeater (or BU) optoelectronic unit and the sea.

- *The repeater (or BU) optoelectronic unit*

The electronic piecepart, made of the optoelectronic regenerator(s), and/or the supervisory circuit(s), and/or the power supply and protection circuit(s), and/or data exchanger(s), and/or redundancy switch(es).

### **A.5.3 Operation of the supervisory and remote maintenance equipment**

The repeater (or BU) supervisory unit permits, in association with the supervisory and remote maintenance equipment in the terminal, fault localisation, repeater performance monitoring and remote controlled redundancy switching, as detailed in A.2.4 above.

## **A.6 Manufacturing and installation**

### **A.6.1 Quality in optical fibre submarine cable systems**

The high performance and reliability requirement established for an optical fibre submarine cable system can be fulfilled only if stringent quality procedures are applied during designing, manufacturing, and laying a system. Although quality procedures are particular to each optical fibre submarine cable supplier, the following basic principles generally apply.

#### **A.6.1.1 Qualification of the designs and technologies**

This activity, part of the development process, is intended to demonstrate that the performance of a technology, a component or an assembly is compatible with meeting the overall system performance and gives reasonable confidence that the reliability target can be met. Qualification includes high stress testing, intended to estimate the ruggedness of the technology, component or sub-assembly and to determine the screening procedure, and long term life testing (some of which might be accelerated for instance by the temperature), the purpose of which is to confirm the validity of the screening procedure and to evaluate the life time and/or the reliability of the technology, component or assembly. Qualification of a cable or submarine equipment may also include sea trials.



### **A.6.1.2 Certification of components and sub-assemblies**

This activity, part of the manufacturing process, is intended to assure the ability of each component or assembly to comply with its performance and reliability specifications once installed. For submarine equipment, each component is individually certified.

The certification is based on the results of screening tests, intended to remove any unsatisfactory item or component, and particularly those likely to exhibit early failures.

### **A.6.1.3 Manufacturing inspection**

This activity, during the manufacturing process, is intended to verify that the quality plan is respected, that each operation is accomplished along the agreed procedure, and that the result is satisfactory.

The responsibility for manufacturing inspection can be shared between the manufacturer and the purchasers of an optical fibre submarine cable system.

## **A.6.2 Assembly and laying procedures**

Route survey is performed prior to cable laying so as to select the cable route and means of cable protection (lightweight protection, armour, burial). The route survey consists in studying the sea depth profile, the sea bottom temperature and seasonal variations, the morphology and nature of the sea bottom, the position of existing cables and pipes, the cable fault history, fishing and mining activities, sea current, seismic activity, national and international laws, etc.

Link assembly consists of jointing the cable sections, the repeaters and the branching units, together with monitoring that the guaranteed margin is present for each fibre in each cable section, so as to constitute the submarine portion. Link assembly can be performed in the cable factory prior to loading, on board the cables ship after loading, or shared between the factory and the cables ship.

Ship loading consists of installing the submarine portion, or fractions of it, on board the cable ship, prior to laying. Ship loading is generally performed with the link unpowered. Tests are made periodically during loading to confirm that the performance of the assembled equipment has not been affected by the loading process.

The system is tested at the end of laying, and may be tested during laying, so as to ensure that no significant system degradation has been induced. Laying testing includes transmission and functional tests, and may include tests on redundant subassemblies. To permit test during cable laying, the link may be powered, provided that safety regulation are respected.

During laying, a predetermined cable overlength (slack) is laid, so as to ensure that the cable is properly laid on the sea bottom..

Laying is normally undertaken only when weather and sea conditions do not create severe risk of damage to the submarine portion, cables ship and laying equipment, or of injury to the personnel.

The cable may be buried in the sea bed to increase cable protection. Burial can be undertaken during laying using a sea plow towed by the laying cables ship, or after laying using a self-propelled submersible robot or other means.

### **A.6.3 System commissioning**

Commissioning testing is performed prior to opening the system to traffic to ensure that the system meets its overall transmission performance, and that all facilities are operational.

If redundancy is used in the design to meet the reliability performance, redundant component could be used for correcting faults occurring during lay or prior to commissioning. However, the objective is to ensure that the number of redundant devices remaining available is sufficient to meet, with a high probability, the target for the number of ship repairs.

## **A.7 Maintenance**

### **A.7.1 Routine maintenance**

Routine maintenance is performed from the terminal stations using the supervisory system. It consists in periodic monitoring of the system parameters and, when required, in preventive redundancy switching.

### **A.7.2 Maintenance at sea**

Optical fibre submarine cable systems can be subject to faults due in particular to external aggression and to component failure. It is important to define and develop well established and efficient repair procedures and equipment, to facilitate repair and limit loss of traffic.

Maintenance at sea is usually performed using dedicated repair cables.

#### **A.7.2.1 Fault localization**

For systems equipped with optical submarine repeaters, a first localization to within one supervisory section is obtained using the supervisory system.

For the end cable sections, cable fault localization may be achieved from the terminal stations, using adequate electrical measurement (resistance, capacitance, insulation, etc.) and optical reflectometry.

Similarly, cable fault localization may be achieved from the cables after cable recovery, using the same methods.

Electroding can be used to locate the cable route.

#### **A.7.2.2 Cable recovery**

During cable recovery it may be necessary, in order to limit the mechanical tension applied to the cable, to cut the cable on the sea bottom prior to recovering both ends separately.

#### **A.7.2.3 Sea repair**

Several methods can be used for sea repair according to the sea depth:

- the shallow water repair may necessitate the addition of a cable length, but not that of a repeater; a repair margin is generally included in the shallow water optical power budget since the shallow water sections are the most exposed to external aggression;
- the deep sea repair usually necessitates the addition of a cable length and of a repeater to compensate for the extra attenuation, if higher than the available margin; generally, no repair margin is included in the deep water optical power budget since deep sea repairs are not frequent.

When a fault is identified to within one supervisory section, the section may be replaced by a mini-system, without further localization. This method may save time, but requires more spare equipment.

Repair safety procedures are applied on board the cables and in the terminal station, so as to ensure the safety of the personnel operating on board the cables. In particular, power safety procedures involve earthing the cable in the terminal station, on board the cables and at branching unit.

TABLE A.1/G.974

**Illustrative system parameters of regenerative optical fibre submarine cable systems**

Systems	280M	420M	560M	2500M	1800M
Development/Commercial use (year)	Commercial use (1987)	Commercial use (1989)	Commercial use (1991)	Development (1993)	Commercial use (1991)
Transmission Capacity (64 kbit/s/ch)	~3840	~5760	~7680	~30 720	~24 192
Information Bit Rate (Mbit/s)	~280	~420	~560	~2488	~1800
Line Bit Rate (Mbit/s)	~296	~442	~591	~2592	~1870
Line Code	24B1P				Scrambled NRZ (SDH)
Maximum System Length (km)	Transoceanic (> 8000 km)				Domestic (~1000 km)
Repeater Spacing (km)	> 50		> 100	> 70	> 100
Water Depth (m)	~8000				
Fibre Type	G.652		G.652, G.654	G.653	
Operating Wavelength (nm)	~1310		~1550		
System DesignLife (year)	25				
Reliability	< 3 Repairs in 25 years			MTBF 10 years	
Error Performance	G.821				
Jitter	G.823				