



INTERNATIONAL TELECOMMUNICATION UNION

ITU-T

TELECOMMUNICATION
STANDARDIZATION SECTOR
OF ITU

G.958

(11/94)

**DIGITAL SECTIONS AND DIGITAL LINE
SYSTEMS**

**DIGITAL LINE SYSTEMS BASED ON THE
SYNCHRONOUS DIGITAL HIERARCHY FOR
USE ON OPTICAL FIBRE CABLES**

ITU-T Recommendation G.958

(Previously "CCITT Recommendation")

FOREWORD

The ITU-T (Telecommunication Standardization Sector) is a permanent organ of the International Telecommunication Union (ITU). The ITU-T is responsible for studying technical, operating and tariff questions and issuing Recommendations on them with a view to standardizing telecommunications on a worldwide basis.

The World Telecommunication Standardization Conference (WTSC), which meets every four years, establishes the topics for study by the ITU-T Study Groups which, in their turn, produce Recommendations on these topics.

The approval of Recommendations by the Members of the ITU-T is covered by the procedure laid down in WTSC Resolution No. 1 (Helsinki, March 1-12, 1993).

ITU-T Recommendation G.958 was revised by ITU-T Study Group 15 (1993-1996) and was approved under the WTSC Resolution No. 1 procedure on the 1st of November 1994.

NOTE

In this Recommendation, the expression "Administration" is used for conciseness to indicate both a telecommunication administration and a recognized operating agency.

© ITU 1995

All rights reserved. No part of this publication may be reproduced or utilized in any form or by any means, electronic or mechanical, including photocopying and microfilm, without permission in writing from the ITU.

CONTENTS

	<i>Page</i>
1 Scope.....	1
2 References.....	1
3 Terms and definitions.....	2
3.1 Definitions.....	2
3.2 Terms defined in other Recommendations.....	2
4 Abbreviations.....	3
5 Applications.....	3
5.1 System types.....	3
5.2 System components.....	4
6 Type of transmission medium.....	5
7 Overall design features.....	5
7.1 System design and optical parameters.....	5
7.2 Transverse compatibility (Recommendation G.957).....	6
7.3 Joint engineering.....	6
7.4 Pattern dependence testing.....	7
8 Transmission overheads.....	7
8.1 Regenerator section model.....	7
8.2 Regenerator model and functionality.....	7
8.3 Regenerator interfaces.....	12
9 General characteristics of synchronous optical line systems.....	12
9.1 Synchronization and timing signal.....	12
9.2 Regenerator timing.....	12
9.3 Jitter performance.....	12
9.4 Error performance.....	15
9.5 Availability and reliability.....	15
9.6 Environmental conditions.....	15
9.7 Laser safety.....	15
10 Operational overview.....	16
10.1 Overview.....	16
10.2 General management functions.....	16
10.3 Fault (maintenance) management.....	16
10.4 Performance management.....	17
10.5 TMN interfaces.....	18
10.6 Orderwire.....	18
Appendix I – Implementation of the CID immunity measurement.....	18
Appendix II – Description of automatic laser shutdown (ALS) capability in case of cable break.....	19
Reference.....	21

SUMMARY

This Recommendation specifies characteristics of digital synchronous line systems based on the synchronous digital hierarchy (SDH) to provide transverse compatibility.

DIGITAL LINE SYSTEMS BASED ON THE SYNCHRONOUS DIGITAL HIERARCHY FOR USE ON OPTICAL FIBRE CABLES

(revised 1994)

1 Scope

This Recommendation provides requirements for digital synchronous line systems based on the synchronous digital hierarchy (SDH) specified in Recommendations G.707, G.708 and G.709. Synchronous line systems described in this Recommendation are intended to provide transverse compatibility, i.e. the possibility of mixing various manufacturers' equipments within a single optical section. This is based on compliance with bit rates, frame structure and detailed mappings as defined in Recommendations G.707, G.708 and G.709, with general characteristics and functionality as given in Recommendations G.782 and G.783, and with operation and maintenance as specified in Recommendation G.784. For the optical parameters of the interfaces used in synchronous line systems, transverse compatibility is based on compliance with Recommendation G.957. These requirements in this Recommendation are also needed to ensure that the synchronous line systems, which are among the first generation of SDH equipment, provide longitudinal compatibility with plesiochronous line systems complying with Recommendation G.955.

2 References

The following Recommendations, and other references contain provisions, which through reference in this text, constitute provisions of this Recommendation. At the time of the publication, the editions indicated were valid. All Recommendations and other references are subject to revision; all users of this Recommendation are therefore encouraged to investigate the possibility of applying the most recent edition of the Recommendations and other references listed below. A list of the currently valid ITU-T Recommendations is regularly published.

- ITU-T G.652 (1993), *Characteristics of a single-mode optical fibre cable.*
- ITU-T G.653 (1993), *Characteristics of a dispersion-shifted single-mode optical fibre cable.*
- ITU-T G.654 (1993), *Characteristics of a 1550 nm wavelength loss-minimized single-mode optical fibre cable.*
- CCITT G.703 (1991), *Physical/electrical characteristics of digital hierarchical interfaces.*
- ITU-T G.707 (1993), *Synchronous digital hierarchy bit rates.*
- ITU-T G.708 (1993), *Network node interface for the synchronous digital hierarchy.*
- ITU-T G.709 (1993), *Synchronous multiplexing structure.*
- ITU-T G.781 (1993), *Structure of Recommendations on equipment for the synchronous digital hierarchy (SDH).*
- ITU-T G.782 (1993), *Types and general characteristics of synchronous digital hierarchy equipment.*
- ITU-T G.783 (1993), *Characteristic of synchronous digital hierarchy (SDH) equipment functional blocks.*
- ITU-T G.784 (1993), *Synchronous digital hierarchy (SDH) management.*
- ITU-T G.955 (1993), *Digital line systems based on the 1544 kbit/s and the 2048 kbit/s hierarchy on optical fibre cables.*
- ITU-T G.957 (1993), *Optical interfaces for equipments and systems relating to the synchronous digital hierarchy.*

3 Terms and definitions

3.1 Definitions

For the purposes of this Recommendation, the following definitions apply:

3.1.1 automatic laser shutdown (ALS): The ALS function of an optical line system automatically switches off the transmitter of a regenerator section in case of cable break in this section.

3.1.2 consecutive identical digit (CID) immunity: The ability of a digital system component to sustain the occurrence of a digital signal containing a continuous stream of binary zeros or ones.

3.1.3 regenerator timing generator (RTG): The RTG function provides a timing reference to the outgoing STM-N signal of a regenerator. This timing reference is derived from the incoming STM-N signal recovered by the SPI function in normal operation, or from an internal oscillator included in the RTG in case of fault.

3.2 Terms defined in other Recommendations

This Recommendation uses the following terms defined in other ITU-T Recommendations:

agent: See Recommendation G.784.

bit interleaved parity order 8 (BIP-8): See Recommendation G.708.

data communications channel (DCC): See Recommendation G.784.

embedded control channel (ECC): See Recommendation G.784.

loss of frame (LOF): See Recommendation G.783.

loss of signal (LOS): See Recommendation G.783.

message communications function (MCF): See Recommendation G.784.

multiplex section alarm indication signal (MS-AIS): See Recommendation G.783.

network element (NE): See Recommendation G.784.

operations system/mediation device (OS/MD): See Recommendation G.784.

out of frame (OOF): See Recommendation G.783.

overhead access (OHA): See Recommendation G.783.

regenerator section overhead (RSOH): See Recommendation G.782.

regenerator section termination (RST): See Recommendation G.782.

S/R reference points: See Recommendations G.955 and G.957.

SDH management subnetwork (SMS): See Recommendation G.784.

SDH physical interface (SPI): See Recommendation G.782.

section overhead (SOH): See Recommendation G.708.

synchronous digital hierarchy (SDH): See Recommendation G.708.

synchronous equipment management function (SEMF): See Recommendation G.782.

synchronous transport module (STM): See Recommendation G.708.

telecommunications management network (TMN): See Recommendation M.3010.

4 Abbreviations

For the purposes of this Recommendation, the following abbreviations apply:

ADM	Add-Drop Multiplexer
AIS	Alarm Indication Signal
ALS	Automatic Laser Shutdown
BER	Bit-Error Ratio
BIP-8	Bit Interleaved Parity Order 8
CID	Consecutive Identical Digit
DCC	Data Communications Channel
DXC	Digital Cross-Connect
E/O	Electrical/Optical
ECC	Embedded Control Channel
I/F	Interface
LOF	Loss of Frame
LOS	Loss of Signal
MCF	Message Communications Function
MS-AIS	Multiplex Section Alarm Indication Signal
MUX	Multiplexer
NE	Network Element
O/E	Optical/Electrical
OHA	Overhead Access
OOF	Out of Frame
OS/MD	Operations System/Mediation Device
PLL	Phase Locked Loop
PRBS	Pseudo-Random Binary Sequence
RSOH	Regenerator Section Overhead
RST	Regenerator Section Termination
RTG	Regenerator Timing Generator
SDH	Synchronous Digital Hierarchy
SEMF	Synchronous Equipment Management Function
SMS	SDH Management Subnetwork
SOH	Section Overhead
SPI	SDH Physical Interface
STM	Synchronous Transport Module
TMN	Telecommunications Management Network

5 Applications

5.1 System types

Figures 5-1 and 5-2 define the reference configurations of the optical line systems specified in this Recommendation and the relationship between Recommendation G.957, this Recommendation and G.780-Series Recommendations for their specification. The two following types of applications are identified:

- 1) inter-office link (see Figure 5-1 and 7.2),
- 2) intra-office link (see Figure 5-2 and 7.2).

These two figures illustrate the fact that Recommendation G.957 specifies the performance of the components of the optical link, from the electro-optic conversion to the opto-electronic one, whereas this Recommendation specifies the performance of the optical link connecting two SDH equipments (multiplexer, digital cross-connect, add-drop multiplexer), including repeaters if any.

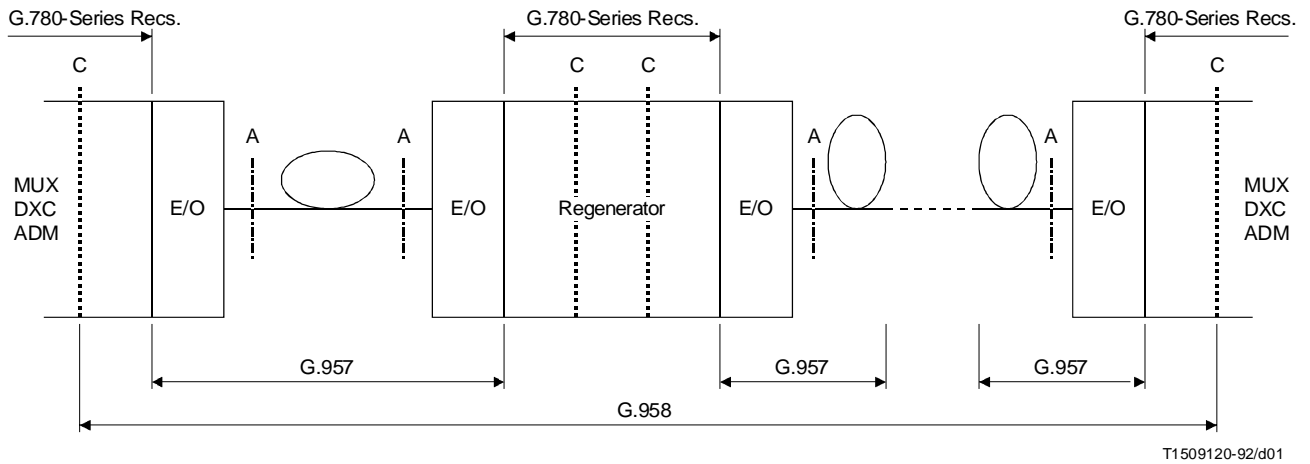
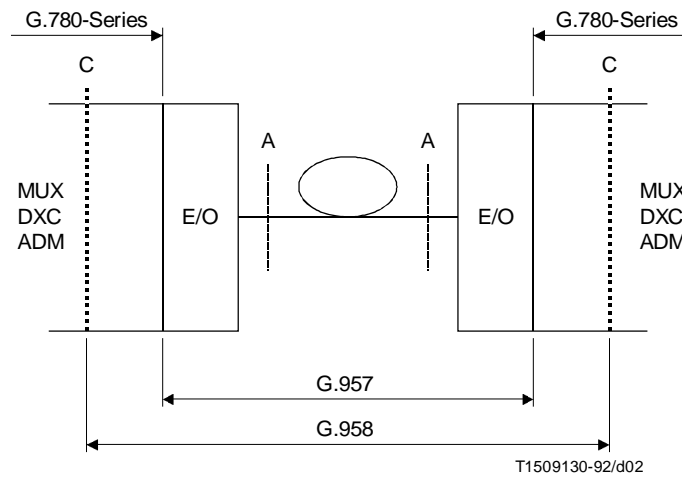

FIGURE 5-1/G.958
Inter-office link



E/O Electro-optical conversion and vice versa
 MUX Multiplexer
 DXC Digital cross-connect system
 ADM Add-drop mux

FIGURE 5-2/G.958
Intra-office link

5.2 System components

A digital line system on optical fibre cables at a given bit rate is usually defined as the means used to implement a digital line section at this bit rate. It comprises line section terminating equipment at both ends, optical fibre sections and regenerators (if needed).

The basic frame structure of SDH provides the overhead necessary for the operation and maintenance of line systems, and therefore, terminal equipment of synchronous line systems will include multiplexing functions. For example, an STM-4 or STM-16 line system will include a synchronous multiplexer to multiplex the synchronous tributaries. If it is used to implement digital line sections at a given G.702 hierarchy level (e.g. 139 264 kbit/s), it will also include the functions needed to map the plesiochronous tributary into the STM-1. The corresponding functions are described in Recommendation G.783.

In order not to constrain equipment design and to ensure compatibility between the various options which may be useful to implement, synchronous line systems are defined for the purpose of this Recommendation as the means used to transport an STM-N stream between the two reference points C of two consecutive synchronous multiplexes.

Synchronous line systems therefore comprise the terminating parts of synchronous multiplexes, i.e. from reference point C to reference point A (see Figure 2-1/G.783), the optical fibre sections and the regenerators if needed.

These components are described in clause 6 (transmission medium), clauses 7, 8 and 9 (overall design features, line termination and regenerators).

Wherever possible, references to the relevant parts of Recommendations G.782, G.783 and G.784 are made, in particular in terms of functional organization and information flows.

This is also illustrated in Figures 5-1 and 5-2.

NOTES

- 1 The figures report functional partitioning, not necessarily physical ones.
- 2 The functional blocks of Recommendation G.783 are not used because the figures are only intended to describe the scope of the various Recommendations related to this Recommendation.
- 3 A and C are reference points as described in Figure 2-1/G.783. Reference point A is equivalent to S/R reference points of Recommendations G.955 and G.957.

6 Type of transmission medium

Single mode optical fibre cables conforming to several Recommendations are allowed in these systems. Recommendation G.652 refers to standard single-mode fibres, Recommendation G.653 to dispersion-shifted fibres, and Recommendation G.654 to loss-minimized fibres. Both the attenuation and dispersion aspects are of particular concern to Recommendation G.957.

The wavelength regions are around 1310 nm for G.652 fibre, and around 1550 nm for G.652, G.653, and G.654 fibres. Within these regions, the wavelength ranges are defined first by cut-off wavelength and by system attenuation and length requirements. Wavelength ranges are specified in Recommendation G.957 for each application.

These fibres may be used with several transmitters; single-longitudinal mode lasers, multi-longitudinal mode lasers, and light-emitting diodes. Spectral characteristics such as chirp, mode-partition noise, and spectral width induce a power penalty, depending upon the fibre dispersion. This will then further limit the operating wavelength ranges.

7 Overall design features

7.1 System design and optical parameters

Prior to the advent of SDH the scope of the design of optical line systems included a large number of parameters such as transmit power range, receiver overload and sensitivity, line code, operating wavelength, operation and maintenance features, etc. This led to a great variety of designs, each having a specific combined optimization of the parameters, the only common parameters being the attenuation and dispersion of the optical path between points S and R. Those systems specified in Recommendation G.955 provided only longitudinal compatibility, i.e. the possibility of parallel installation on the same cable route. Interconnection between two operators could be achieved either through joint engineering of the optical link, or interconnection at a hierarchical level. (Joint engineering is defined in 7.3 below.)

Synchronous line systems described in this Recommendation are intended to provide transverse compatibility, i.e. the possibility of mixing various manufacturers' equipments within a single optical section. This is based on compliance with bit rates, frame structure and detailed mappings as defined in Recommendations G.707, G.708 and G.709, with general characteristics and functionalities as given in Recommendations G.782 and G.783, and with operation and maintenance as specified in Recommendation G.784.

For the optical parameters of the interfaces used in synchronous line systems, transverse compatibility is based on compliance with Recommendation G.957. Recommendation G.957 is summarized in 7.2.

7.2 Transverse compatibility (Recommendation G.957)

Recommendation G.957 (Optical interfaces for equipments and systems relating to the synchronous digital hierarchy), provides specifications for the optical interfaces of SDH equipment, described in Recommendations G.782 and G.783, and line systems described in the present Recommendation, to achieve the possibility of transverse compatibility on elementary cable sections, i.e. mixing various manufacturers' equipments within a single optical section. These specifications also provide longitudinal compatibility with line systems of comparable hierarchical level and application which are in accordance with Recommendation G.955.

The applications belong to these three categories with regard to the achievable repeater span:

- intra-office for distances less than approximately 2 km;
- short-haul inter-office for distances of approximately 15 km;
- long-haul inter-office for distances of approximately 40 km (1310 nm window) or 80 km (1550 nm window).

Within each category' further subdivisions are made depending on the fibre type and wavelength region as described in clause 7 above. This leads to one intra-office specification, two inter-office short-haul specifications and three inter-office long-haul specifications for each bit rate.

For each application separate specifications are given for the transmitter at point S, the receiver at point R and the optical path between S and R.

Recommendation G.957 also contains the definition of each parameter used. Corresponding measurement methods are under study and should eventually be included in Recommendation G.957.

The relationship between the parameters of the constituents of the optical link is also described in clause 5/G.957 in order to establish a common system design approach for engineering SDH optional links. This can be used to select a suitable interface for a given regenerator section, depending on the characteristics of the optical path of this section.

It should be noted that the specifications given in Recommendation G.957 are based on worst-case parameter values to provide simple design guidelines for network planners and explicit component specifications for manufacturers. It is recognized that, in some cases, this may lead to more conservative design than could be obtained through joint engineering of the optical link, the use of statistical equipment design approaches (statistical and semi-statistical design approaches are described in Recommendation G.957), or in applications and environments more constrained than those permitted under the standard operating conditions.

It is believed that this approach is sufficient to meet the requirements of the great majority of cases. Subclause 7.3 below discusses those cases where there is a need for an improved level of performance.

7.3 Joint engineering

For a limited number of cases joint engineering may be envisaged to meet the requirements of optical sections where the interface specifications of Recommendation G.957 prove inadequate. This will probably occur where the required section loss is greater (e.g. 2 dB) than that specified in Recommendation G.957 but may also be considered for other parameters.

For those cases it is up to the Administrations/operators concerned to specify more closely the aspects of the system where the specifications of Recommendation G.957 are not satisfactory. It is important to stress that every situation requiring "joint engineering" is likely to be different – hence it is meaningless to try to standardize any of the parameter values for these systems. Instead, it is for the Administrations/operators concerned to come to an agreement as to what is required and then negotiate with manufacturers as to what is actually feasible. This process is very likely to lead to both ends of a transmission link being supplied by the same manufacturer, who meets the required performance by jointly optimizing the transmitters and receivers.

It should be pointed out that, in spite of the futility of specifying any parameter values for “jointly engineered” systems, it would be advisable for Administrations/operators or manufacturers involved to follow the general guidelines and system engineering approach used in Recommendation G.957. In particular, it would be helpful to use the same parameter definitions as Recommendation G.957 (e.g. receiver sensitivity at R-reference point including all temperature and ageing effects).

7.4 Pattern dependence testing

STM-N signals contain regions within the data stream where the possibility of bit errors being introduced is greater due to the structure of the data within these regions.

Three cases in particular may be identified:

- 1) errors resulting from eye-closure due to the tendency for the mean level of the signal within the equipment to vary with pattern-density due to alternative current couplings (“DC wander”);
- 2) errors due to failure of the timing recovery circuit to bridge regions of data containing very little timing information in the form of data transitions;
- 3) errors due to failure of the timing recovery circuit as in 2) above but compounded by the occurrence of the first row of the STM-N section overhead bytes preceding a period of low timing content (these bytes have low data content, particularly for large N).

In order to verify the ability of STM-N equipment to operate error-free under the above conditions, a possible method to assess the consecutive identical digit (CID) immunity of a circuit block is presented in Appendix I.

This method may be employed during the design phase of the equipment and appropriate points in the production assembly process.

8 Transmission overheads

This section describes the regenerator section overhead (RSOH) processing functionality in a synchronous line system. The definition of a regenerator section (see Figure 8-1) and the functional description of a regenerator (see Figure 8-2) are based on the functional block description of Recommendation G.783. The functional blocks and the signals are bidirectional where necessary. These descriptions are logical descriptions, not suggested implementations.

8.1 Regenerator section model

The regenerator section model is illustrated in Figure 8-1. The definitions of the functions and signals at reference points are given in Recommendation G.783.

A regenerator section is defined as the part of an SDH link between two adjacent reference points C, i.e. where the RSOH is generated and included in the STM-N frame and where the RSOH is extracted from the STM-N frame and terminated. Regenerator section end equipments may be multiplexers (or cross-connect systems) and/or regenerators. In case of intra-office links both ends are multiplexers (or DXCs).

8.2 Regenerator model and functionality

The regenerator model is shown in Figure 8-2. The functional blocks and the signals at the reference points are the same as those described in Recommendation G.783, except where noted below.

In the following description, signal flows from left to right of Figure 8-2.

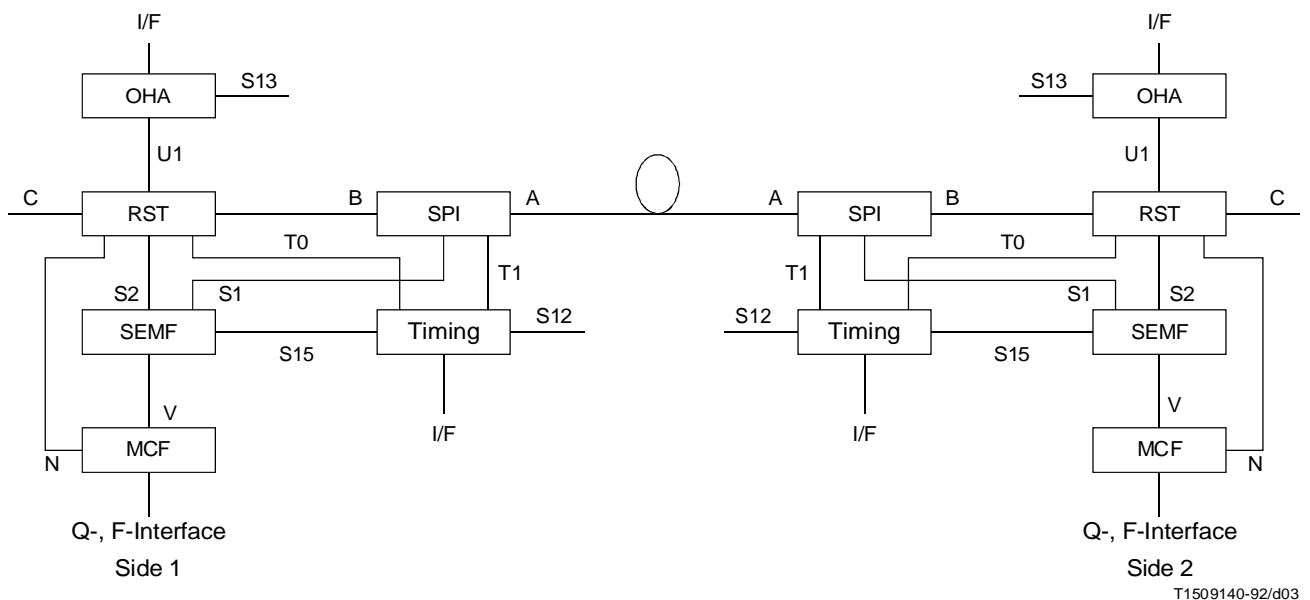

- OHA Overhead access
- SPI SDH physical interface
- RST Regenerator section termination
- SEMF Synchronous equipment management function
- MCF Message communication function
- I/F Interface

FIGURE 8-1/G.958
Regenerator section model

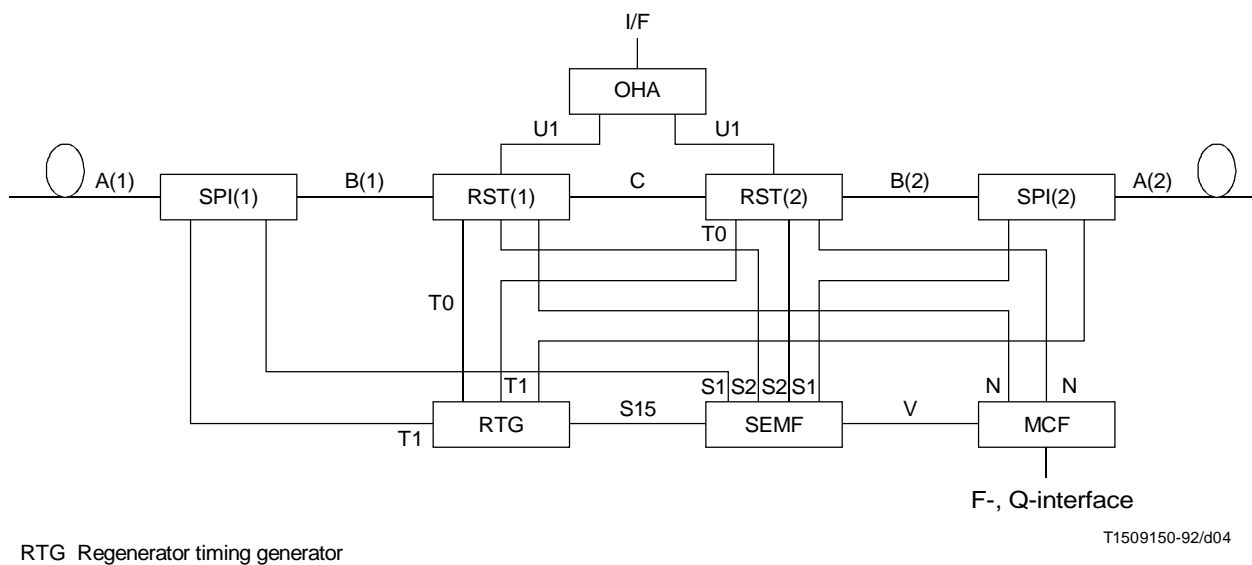

RTG Regenerator timing generator

FIGURE 8-2/G.958
Regenerator model

The signal at reference point A(1) is the STM-N line signal. Reference point A(1) physically corresponds to reference point R in Recommendation G.955. The characteristics of the optical signal at this reference point are given in Recommendation G.957.

STM-N signal entering at reference point A(1) is electrically regenerated by the SDH physical interface function SPI(1) at reference point B(1).

SPI(1) converts the signal at reference point A(1) into the sequence of logical levels forming the signal at reference point B(1), for which SPI(1) must grant the characteristics necessary to meet the required transmission and network performance. Transmission performance requirements for synchronous optical systems are given in clauses 9 and 10 and the network performance requirements are given in Recommendation G.782. Timing is extracted from the incoming signal and is made available at reference point T1 to the regenerator timing generator (RTG), and at reference point B(1) to the RST(1). RTG requirements are contained in clause 9.

The status of the received signal is monitored to detect input signal failures. Input signal fail conditions and related parameters are defined in clause 10. The signal fail condition is reported to the synchronous equipment management function (SEMF) through reference point S1 and to RST(1) through reference point B(1). The SEMF monitors all the regenerator functions for management and control as described in 8.2.5.

The RST(1) function recovers the frame alignment from the fully formatted and regenerated STM-N data and associated timing at B(1). Criteria for frame alignment algorithm, for out-of-frame condition (OOF), loss of frame state (LOF) and the associated reporting to SEMF through the S2 reference point are described in Recommendation G.783.

Then the RST(1) function descrambles the signal at B(1), using the recovered frame alignment and extracts the RSOH bytes. Scrambling in the regenerator is described in 8.2.1.

In an STM-N frame, the use of only a subset of the RSOH bytes is defined. The definitions of these bytes and their positions in the STM-N frame are given in Recommendation G.708 and described in detail for SDH equipment in Recommendation G.783. In this clause, features specific to regenerators of synchronous line systems are described.

The B1 byte is used to locate faulty regenerator sections. The B1 byte is monitored and the result is reported to SEMF through reference point S2.

Byte E1 provides an orderwire voice channel between section terminations. Byte E1 is passed to the overhead access (OHA) function at reference point U1. The OHA function in the regenerator provides the means for accessing specific overhead capacities in RSOH. In the case of a 1:N line protection system, it is not necessary for all regenerators within the same repeater station to access the orderwire signal. Further details on the orderwire function are given in clause 7/G.783.

The F1 byte is the user channel and is also passed to the OHA function. The access of the user channel in the regenerator is optional. An example of use of the F1 byte to identify a failed section in a chain of regenerator sections is reported in Appendix I/G.783.

Data communication channels (DCC) bytes D1-D3 are routed to the message communication function (MCF) through reference point N. The use of DCC is described in Recommendations G.783 and G.784.

Regenerators should be capable of ignoring the national use bytes and bytes reserved for future international standardization.

The RST function might need to access other bytes for medium dependent use (see 8.2.3 below).

The signal at reference point C is an STM-N frame with the associated timing signal. The RST(2) function inserts RSOH bytes to the data at reference point C, performs the scrambling and presents the fully formatted STM-N data to SPI(2) at reference point B(2).

The RSOH bytes to be inserted are generated at RST(2), taken either from the OHA through reference point U1 or from the MCF through reference point N, or relayed from RST(1).

Under normal operation [i.e. in-frame condition at RST(1)]:

- A1, A2 and C1 bytes are either generated or relayed. Relaying the received framing bytes reduces the delay in the detection of OOF and recovery from failure in a chain of regenerators. Fault sectionalization capability is not affected because B1 is recalculated for each regenerator section. From a management viewpoint, it is preferable that all the regenerators in a line system conform to either one or other approach.
- B1 is generated as described in Recommendation G.783.

- E1 and F1 are taken from the OHA; optionally they may be relayed.
- D1-D3 are taken from the MCF.
- National use bytes and bytes reserved for future international standardization in the RSOH are either relayed or generated as described in Recommendation G.783.

When RST(1) is in a failure state described in 8.2.2:

- A1, A2 and C1 are generated;
- B1 is generated as described in Recommendation G.783;
- E1 and F1 are taken from the OHA;
- D1-D3 are taken from the MCF;
- national use bytes and bytes reserved for future international standardization in the RSOH are generated as specified in Recommendation G.783.

When RST(1) is in OOF condition (but not in a failure state as described in 8.2.2) all RSOH bytes may be relayed.

SPI(2) converts the logical levels of the signal at reference point B(2) into optical pulses at reference point A(2). The SPI function must provide the characteristics of the signal necessary to meet the required transmission and network performance. Reference point A(2) physically corresponds to reference point S in Recommendation G.955. The characteristics of the optical signal at this reference point is given in Recommendation G.957. Parameters related to the status of the transmitter are sent to SEMF through reference point S1. Parameters to be monitored are defined in clause 10.

8.2.1 Scrambling in the regenerator

In order to clearly define the scrambling and descrambling processes, a functional diagram of the signal path in the RST is shown in Figure 8-3, according to the algorithm reported in Recommendation G.709.

The upper part shows the transmission side of RST. Firstly the complete STM-N frame, including B1 byte computed on the previous frame, is built, the STM-N frame is then scrambled, except for the first SOH row, i.e. the first $N \times 9$ bytes, and finally the BIP-8 is computed over the entire scrambled frame. The BIP-8 value will be included in the next frame as B1 byte.

Similarly the central part shows the receive side of RST. Before descrambling, frame alignment is searched or verified on the received STM-N signal and BIP-8 is computed. Then the STM-N frame is descrambled, except for the first SOH row, i.e. the first $N \times 9$ bytes, and the RSOH is subsequently used, including B1 byte.

The lower part of the Figure 8-3 shows the entire STM-N frame.

This description is only functional, and does not imply any particular physical implementation. The regenerator has to access only the RSOH bytes, and in principle needs to descramble and scramble only these bytes. Therefore data at C to be passed from RST(1) to RST(2) may actually be passed transparently from B(1) to B(2) rather than being descrambled at RST(1) and scrambled at RST(2).

8.2.2 Alarm indication signal (AIS)

Under the failure cases mentioned in Recommendation G.783 (i.e. loss of signal or loss of frame), resulting in a logical all ones signal at reference point C, the signal at C and valid RSOH added at B(2) results in an MS-AIS. Recommendation G.783 specifies the delay to activate and deactivate MS-AIS.

8.2.3 Medium dependent use of overhead bytes

It is possible that in the future some bytes may be dedicated to functions specific to a particular transmission medium. These bytes could be taken from those reserved for national use and future international standardization. Otherwise, bytes already defined could be modified in their use to include medium specific requirements.

8.2.4 Intra-office link

Reduced functionality to be used in intra-office link regenerator sections are described in 5.2.3/G.708.

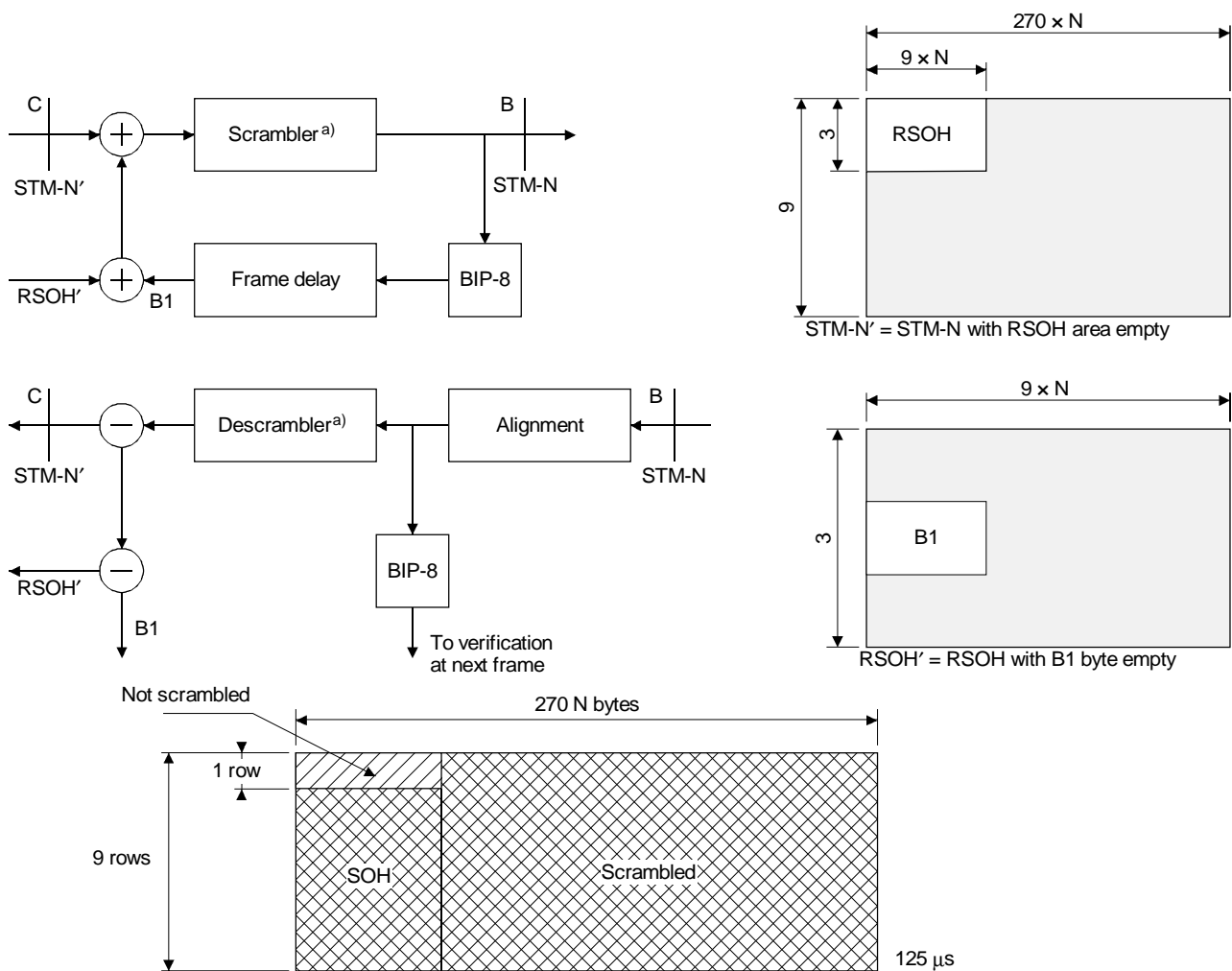

a) All STM-N contents except first RSOH row, i.e. first $9 \times N$ bytes of the frame.

T1509160-92/d05

FIGURE 8-3/G.958
Scrambling in RST

8.2.5 Management

The general SDH control and management principles and the interworking with TMN illustrated in Recommendation G.784 apply to the regenerator. The SDH management architecture, the communication network structure among different network elements (NE) and a model for the regenerator are shown in Recommendation G.784.

The regenerator includes an SEMF. It contains a number of filtering functions that translate primitive information, coming from the functional blocks, to forms usable by the network management and vice versa. Some information is not processed by a filtering function. The filtering functions used in a regenerator are described in detail in Recommendation G.783. The possible use of internal storage for performance parameters history retrieval, the ability of generating autonomous alarm reports on threshold crossings and the possibility of setting externally the threshold values are described in Recommendation G.784. In the regenerator an agent is present in the SEMF, which controls the exchange of information with other SDH network elements or with the TMN for management purposes. Characteristics of the agent are given in Recommendation G.784.

Messages are sent over the embedded control channel (ECC) that utilizes DCC, i.e. D1-D3 bytes as the physical layer. The protocol stack used and the message generation and termination methods are described in Recommendation G.784.

Messages are transmitted and received by the message communication function (MCF), which is connected to the SEMF through V reference point and to a Q-interface when provided.

Incoming bytes D1-D3 are extracted by the RST function and routed to the MCF through reference point N. Relayed messages and locally generated messages are sent through reference point N as D1-D3 bytes to the RST function, which inserts them into the RSOH of the outgoing STM-N frame.

Two interfaces towards elements external to the SDH network may be used. The Q-interface can connect the regenerator to an operation system/mediation device (OS/MD). The F-interface may be used to connect the regenerator to a workstation for monitoring and maintenance purposes.

8.3 Regenerator interfaces

The regenerator has the following interfaces:

- *S-reference point on both transmitting fibres* – The interface characteristics at this reference point are specified in Recommendation G.957.
- *R-reference point on both receiving fibres* – The interface characteristics at this reference point are specified in Recommendation G.957.
- *Interface for orderwire channel* – The interface characteristics at this reference point are specified in Recommendation G.783.
- *Interface for user channel* – To be defined.
- Use of a Q-interface may be foreseen in some applications.
- *F-interface to a workstation* – Its characteristics are under study.

9 General characteristics of synchronous optical line systems

9.1 Synchronization and timing signal

The structure and details of synchronization and timing signals are described in Recommendation G.782.

9.2 Regenerator timing

Figure 9-1 illustrates the timing functions for regenerators. The regenerator timing generator (RTG) includes an internal oscillator. In normal operation, the SPI function recovers the timing from the incoming STM-N signal at reference point A and passes the data and timing to RST at reference point B, and passes the timing signal also to the RTG function at reference point T1. The RTG function provides the timing signal to the outgoing STM-N signal at reference point T0. The directionality of the timing signals is maintained.

When transmitting MS-AIS, the RTG shall provide timing for the outgoing STM-N signal at reference point T0 using the internal oscillator. The long-term frequency stability of the internal oscillator in free-running mode shall be equal to or better than ± 20 ppm.

The RTG and SPI functions must accommodate timing from an incoming MS-AIS signal.

9.3 Jitter performance

This subclause deals with jitter requirements for optical interfaces at the STM-N levels as defined in Recommendation G.707. Specifications for multiplex jitter and wander at STM-N and Recommendation G.703 interfaces are described in Recommendations G.782 and G.783.

The purpose of the jitter requirements in these subclauses is to control the accumulation of jitter within SDH line systems. SDH line equipment jitter specifications are organized into limits for the following: jitter generation, jitter transfer and jitter tolerance.

9.3.1 Jitter generation

Jitter generation is defined as the amount of jitter at the STM-N output of SDH equipment.

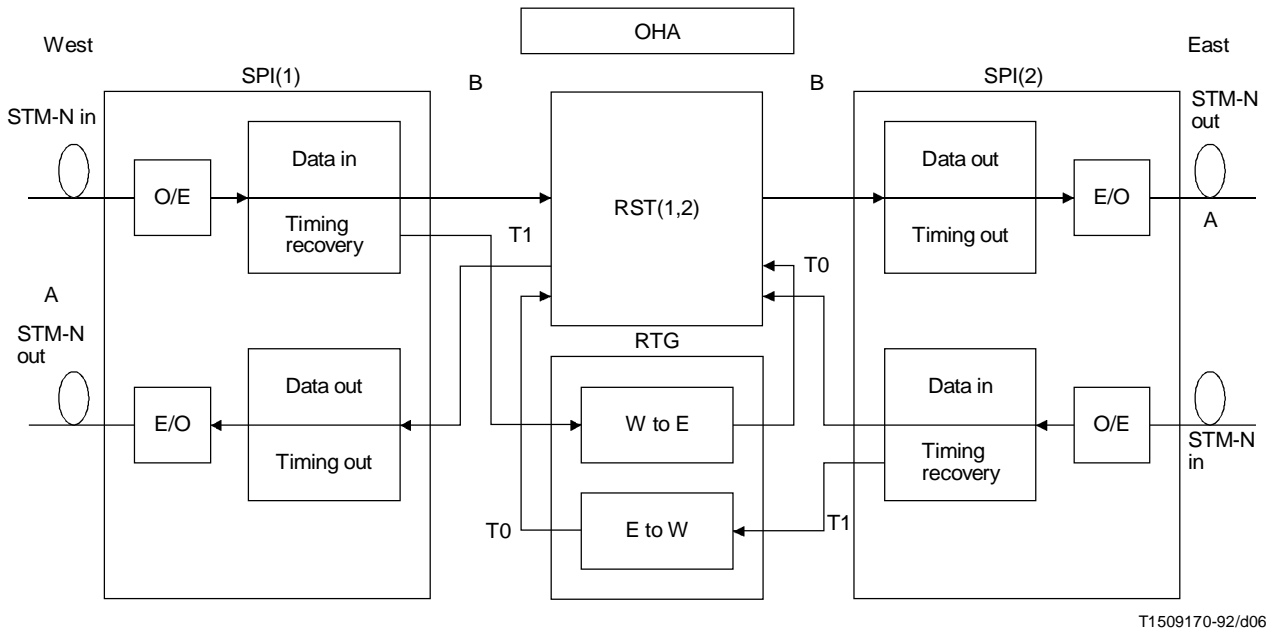

FIGURE 9-1/G.958
Description of the regenerator timing functions

An SDH regenerator shall not generate more than 0.01 UIrms jitter, with no jitter applied at the STM-N input. The measurement bandwidth and technique are under study.

9.3.2 Jitter transfer

Jitter transfer specification applies only to SDH regenerators.

The jitter transfer function is defined as the ratio of jitter on the output STM-N signal to the jitter applied on the input STM-N signal versus frequency.

The jitter transfer function of an SDH regenerator shall be under the curve given in Figure 9-2, when input sinusoidal jitter up to the mask level in Figure 9-3 is applied, with the parameters specified for Type A in Table 9-1 for each bit rate.

If an SDH regenerator meets the jitter transfer specification for Type B, it is classified as Type B regenerator.

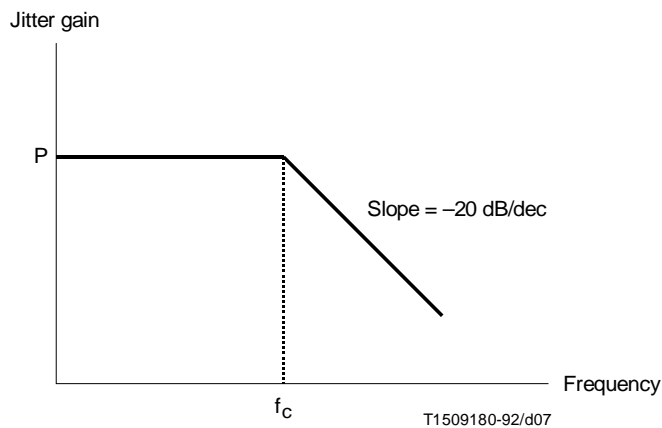

FIGURE 9-2/G.958
Jitter transfer

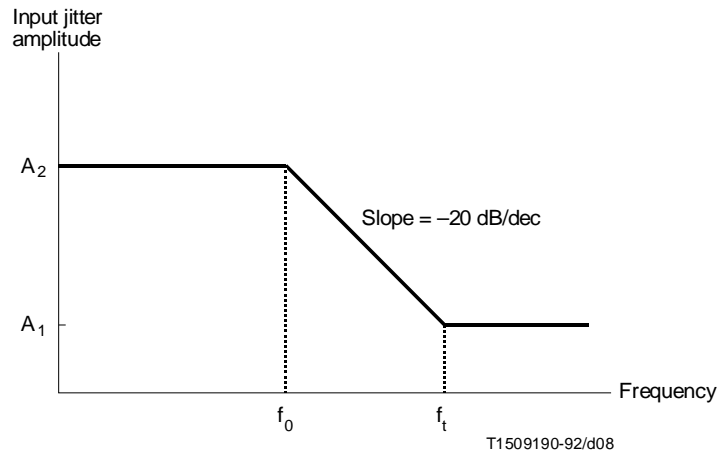

FIGURE 9-3/G.958
Jitter tolerance mask

TABLE 9-1/G.958

Jitter transfer parameters

STM-N level (type)	f_c (kHz)	P (dB)
STM-1 (A)	130	0.1
STM-1 (B)	30	0.1
STM-4 (A)	500	0.1
STM-4 (B)	30	0.1
STM-16 (A)	2000	0.1
STM-16 (B)	30	0.1

9.3.3 Jitter tolerance

Jitter tolerance is defined as the peak-to-peak amplitude of sinusoidal jitter applied on the input STM-N signal that causes a 1 dB optical power penalty at the optical equipment. Note that this is a stress test to ensure that no additional penalty is incurred under operating conditions. This technique is described in Supplement No. 3.8 of the O-Series Recommendations:

- 1) SDH line terminals and regenerators to be used in line systems including type A regenerators shall tolerate, as a minimum, the input jitter applied according to the mask in Figure 9-3, with the parameters specified in Table 9-2 for each STM-N level.
- 2) SDH line terminals and regenerators to be used in line systems with only type B regenerators, or in line systems without regenerators, may have reduced jitter tolerance. Such equipment shall tolerate, as a minimum, the input jitter applied according to the mask in Figure 9-3, with the parameters specified in Table 9-3 for each STM-N level.
- 3) The interworking of SDH line terminals and regenerators having reduced jitter tolerance as per (2), with type A regenerators in the same line system depends on network jitter limits specified in Recommendation G.825. SDH equipment with reduced jitter tolerance may require some jitter reduction in the case they follow a chain of type A regenerators.

TABLE 9-2/G.958

Jitter tolerance parameters

STM-N level	f_t (kHz)	f_0 (kHz)	A_1 (UIp-p)	A_2 (UIp-p)
STM-1	65	6.5	0.15	1.5
STM-4	250	25	0.15	1.5
STM-16	1000	100	0.15	1.5

TABLE 9-3/G.958

Parameters for reduced jitter tolerance

STM-N level	f_t (kHz)	f_0 (kHz)	A_1 (UIp-p)	A_2 (UIp-p)
STM-1	12	1.2	0.15	1.5
STM-4	12	1.2	0.15	1.5
STM-16	12	1.2	0.15	1.5

9.4 Error performance

The synchronous line systems specified in this Recommendation should meet the relevant performance objectives of Recommendation G.821 under the worst environmental conditions. In particular, they are required to provide at least error performance in accordance with “section quality classification 1” defined in Recommendation G.821.

9.5 Availability and reliability

For further study.

9.6 Environmental conditions

For further study.

9.7 Laser safety

For safety considerations, according to Reference [1] or national regulations, it may be necessary to provide for an automatic laser shutdown (ALS) facility of the laser in case of cable break.

This function is considered as optional. In particular, it is not necessary for Class 1 systems under IEC 825-1 (1993).

Appendix II shows the required functionality of automatic laser shutdown when implemented.

In case automatic laser shutdown facility is implemented the following command, configuration and provisioning information will flow over the S1 reference point (refer to Table 4-17/G.783):

S reference point	Get	Set
S1	ALS implemented ALS enabled/disabled Tx output on/off	ALS enabled/disabled Tx output on/off

If automatic laser shutdown is implemented, it should not impair fault sectionalization capability in case of loss of signal at the transmitter or the receiver due to causes other than a cable break.

10 Operational overview

10.1 Overview

The operation, administration and maintenance features of digital synchronous line systems should be designed in accordance with Recommendations M.20 (Maintenance philosophy for telecommunication networks), M.3010 (Principles for a telecommunications management network) and G.784.

In particular, management principles should be based on the concepts defined in Recommendation M.3010:

- functional organization of management functions (configuration, performance, faults);
- functional description of network elements in managed objects.

The synchronous line system may be considered from the point of view of management as a SDH management subnetwork (SMS as defined in Recommendation G.784). The architecture, embedded control channel (ECC) functions, information model and ECC protocols should therefore conform to the specifications given in Recommendation G.784.

In particular, the information model should follow the specifications given in Recommendation G.784.

It should also be noted that synchronous line systems defined in this Recommendation should provide autonomous management functions (performance monitoring, fault location, alarm generation) for early implementations where the connection to a TMN is not possible. The way in which this could be done while retaining forward compatibility with the full deployment of TMN features is for further study.

10.2 General management functions

The synchronous line systems should provide the general management functions described in Recommendation G.784.

10.3 Fault (maintenance) management

The synchronous line systems should support the fault management functions described in Recommendation G.784.

10.3.1 Alarm surveillance

This subclause describes parameters which should be monitored in the synchronous line systems. In general, these parameters are monitored to assist with fault localization. They are not intended to act as the primary indication of link failure.

10.3.1.1 Parameters to be monitored at the S1 reference point

10.3.1.1.1 Loss of incoming signal

This parameter should take on the value “incoming signal absent” when the incoming power level at the receiver has dropped to a level which corresponds to a high error condition. The purpose of monitoring this parameter is to indicate either:

- i) transmitter failure;
- ii) optical path break.

Note that this is a functional specification referring only to the quality of the incoming signal. It does not necessarily imply either the measurement of optical power or BER. The timing requirements for detection of the LOS defect are for further study.

10.3.1.1.2 Transmit fail (transmit power out-of-range)

This parameter should indicate whether the transmitter power level is in the range specified in Recommendation G.957 for the defined application code. It will therefore have two values: within range, and out of range. Some form of hysteresis and integration time has to be provided (for further study). It is recognized that, without the use of a coupler and additional detector, the only parameter that can give an indication of the transmitter output power is the current passing through the laser back-facet monitor diode. Under certain fault conditions, the circuit controlling this current may mask significant variations in the laser output power. The exact power level at which this parameter takes on the value “out of range” is not specified. The purpose of monitoring this parameter is to indicate whether a serious fault exists in the transmitter.

10.3.1.1.3 Transmit degraded (laser bias out of limits)

This parameter should be used to monitor the bias current of the laser of the transmitter. The purpose of monitoring this parameter is to indicate laser degradation well in advance of catastrophic failure of the link. The value at which this parameter takes on the value “bias out of limits” is not specified.

10.3.1.1.4 Transmit degraded (laser temperature out of range)

This parameter can have the values “temperature within range/temperature out of range”. The purpose of monitoring this parameter is to indicate failure of the transmitter temperature control circuitry. The value at which this parameter takes on the value “temperature out of range” is not specified.

10.3.1.2 Parameters to be monitored at the S2 reference point

The corresponding requirements are contained in Recommendation G.783.

10.3.2 Testing

10.3.2.1 Loopbacks

It is considered that the loss of signal indications at the receiver and at the transmitter provide sufficient resolution for practical fault sectionalization and that loopbacks, optical or otherwise, are not necessary.

The need for test points or loopbacks for testing purposes is under study.

10.3.3 External events

This point concerns the case where there is a need to monitor through the synchronous line system site related alarms (door opening or fire in an unmanned station, etc.) or more generally a non-SDH network element. The corresponding implementation and requirements are under study.

10.4 Performance management

The synchronous line systems should support the performance management functions described in Recommendation G.784.

These functions should be implemented using information flows at reference points S1 and S2 and filtering functions described in Recommendation G.783.

10.5 TMN interfaces

Synchronous line systems should provide at least one interface at each end conforming to Recommendation G.773.

10.6 Orderwire

The E1 byte may be used for conferencing between line terminal stations and/or regenerator stations. The E2 byte may be used for express point-to-point communication between terminal stations.

The definition of orderwire ports and associated signalling procedures is not in the scope of this Recommendation.

Appendix I

Implementation of the CID immunity measurement

(This appendix does not form an integral part of this Recommendation)

Summary

Alternating digital signal patterns may be used to verify the adequacy of timing-recovery and low-frequency performance of STM-N equipments.

Appropriate pattern sequences are defined below and in Figure I.1.

This test does not attempt to simulate conditions which may occur under anomalous operating conditions to which the equipment may be subjected.

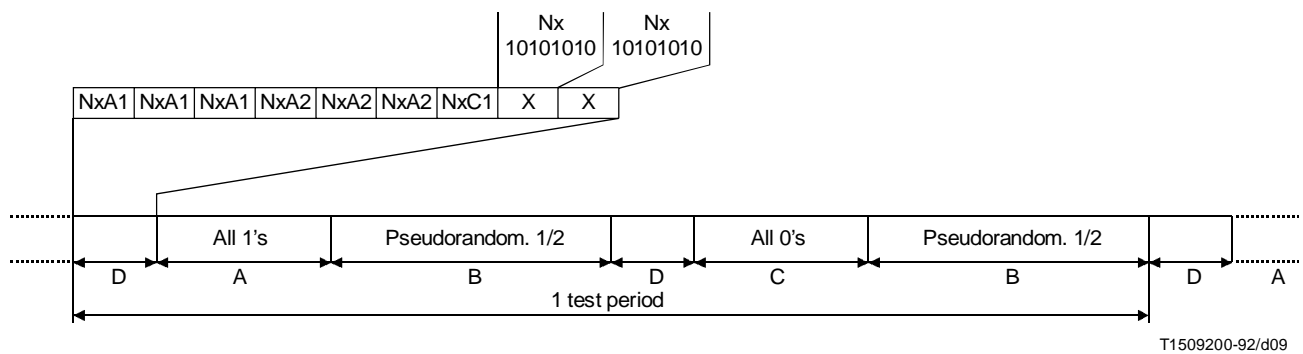

FIGURE I.1/G.958
STM-N pattern dependence test sequence

Description

The specific test patterns are made up of consecutive blocks of data of four types:

- all ones (zero timing content, high average signal amplitude);
- pseudo-random data with a mark-density ratio of 1/2;
- all zeros (zero timing content, low average signal amplitude);
- a data block consisting of the first row of section overhead bytes for the STM-N system under test.

The test pattern is shown in Figure I-1 where the regions A, B, C and D are identified.

The duration of the zero-timing-content periods A and C is made equal to the longest like-element sequences expected in the STM-N signal. A value of nine bytes (72 bits) is provisionally proposed for this.

The duration of the pseudo-random periods should allow recovery of both the zero base line offset of the signal and of the timing recovery circuit following occurrence of the A and C periods. Therefore it should be longer than the longest time constant in the regenerator. In the case of a PLL based clock extraction, this could give a value of the order of 10 000 bits. Taking into account possible limitations of test equipment, a minimum value of 2000 bits is considered acceptable.

The content of the pseudo-random section should be generated by a scrambler having the same polynomial as defined in Recommendation G.709. Ideally, the scrambler should “free-run”, i.e. the beginning of the pattern should be uncorrelated with the frame alignment section. This arrangement will ensure that the system experiences the worst possible phasing of the PRBS at some point during the course of the test. However, it is recognized that test equipment limitations may preclude the use of a free running scrambler. Hence it may be necessary to specify a worst-case phasing of the PRBS. This is for further study.

The D-period is defined as the first row of the section overhead of the STM-N signal, including valid C1 bytes (consecutive binary numbers).

It is recommended that this test be applied to SDH systems at any appropriate point in time during the design or production phase. This would be done to demonstrate the ability of both timing-recovery and decision circuits adequately to handle worst-case SDH signals.

It should be emphasized that the test pattern may be rejected by or cause malfunction of certain equipments because, for example, the occurrence of the frame alignment bytes within the pattern. The test should therefore only be used for assemblies not so affected, such as timing recovery units, receiver amplifier chains, etc.

However, the test may be applicable in certain cases at the available user ports. It is not proposed as a general acceptance test which might require special defined access ports and connection arrangements within the equipment.

Appendix II

Description of automatic laser shutdown (ALS) capability in case of cable break

(This appendix does not form an integral part of this Recommendation)

If a cable break happens at point A of Figure II.1, the consecutive loss of signal at RX₂ is used to cut TX₂ which is the adjacent transmitter in the opposite direction. This in turn leads to a loss of signal in RX₁ which switches off TX₁.

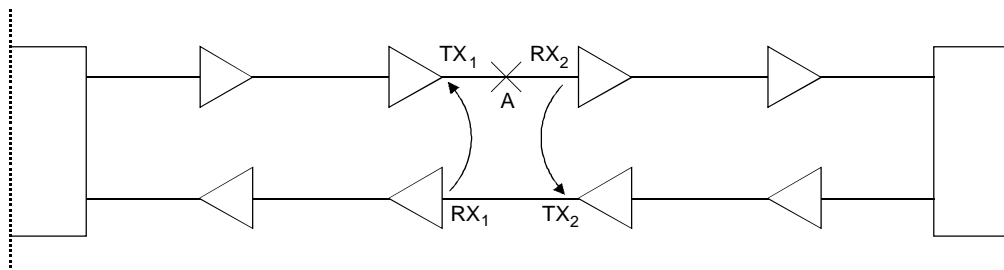

T1509210-92/d10

FIGURE II.1/G.958
Description of ALS capability in case of cable break

For test and monitoring purposes it is possible to override the shutdown mechanism by switching on the laser manually.

When the cable has been repaired either an automatic or a manual action according to Figure II.2, at TX₁ or TX₂ is necessary to restore correct transmission.

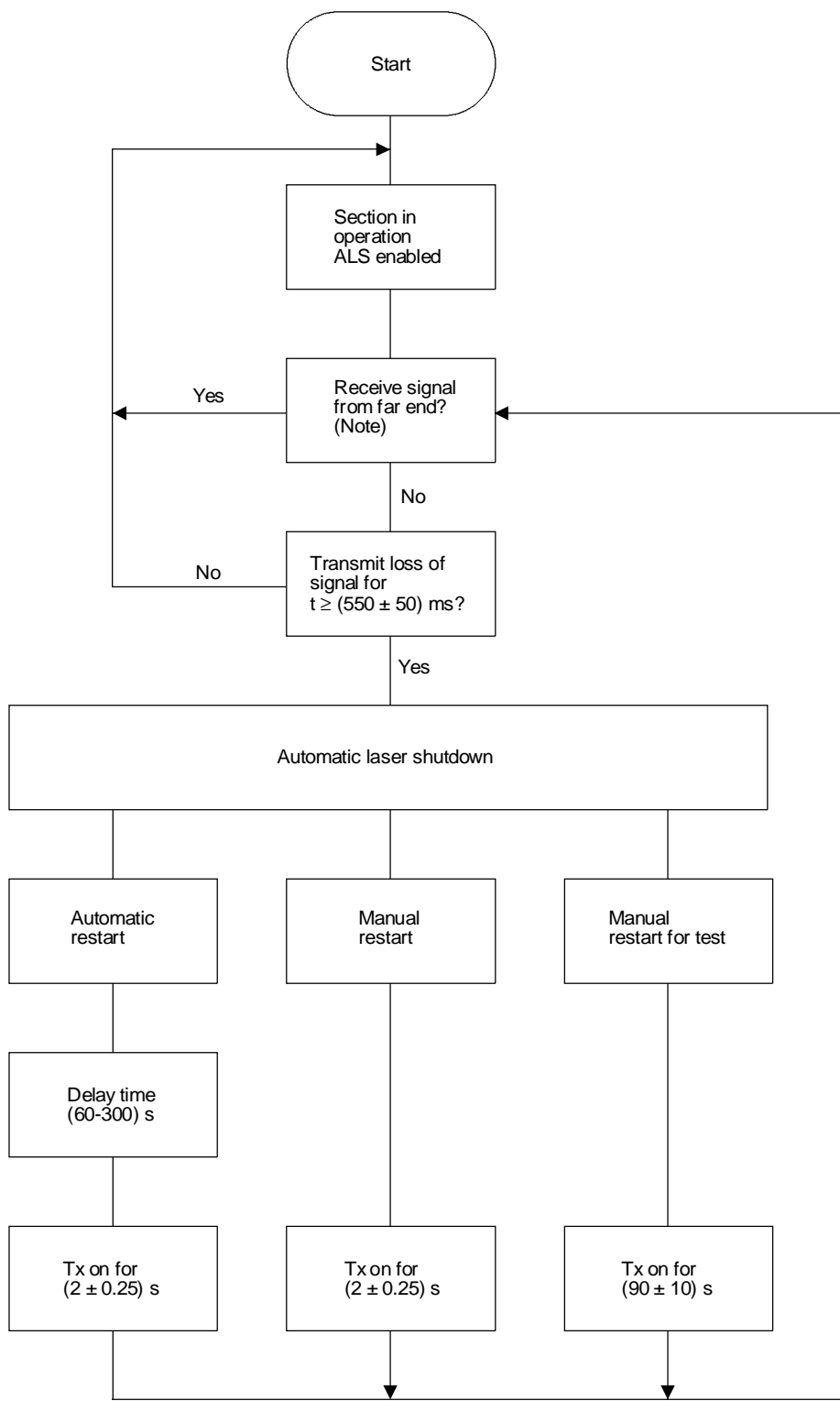

T1506090-90/d11

NOTE – “Receive signal from far end?” is also active when the transmitter is in the shutdown situation.

FIGURE II.2/G.958
Automatic laser shutdown and restart concept
including optional test procedure

The response time of the transmitter/receiver combination, measured from receiver input (point R) to transmitter output (point S) should be less than 0.85 seconds. This response time of 0.85 seconds refers to the time difference between the moment light enters the receiver at point R and the moment the transmitter starts light emitting at point S in case the transmitter is in the shut down situation.

“Manual restart” or “Manual restart for test” can only be activated when the laser is shut down.

In case 1 + 1 protection switching is implemented, a working channel receiver should shut down a working channel transmitter. Similarly, a protection channel receiver should shut down a protection channel transmitter.

Reference

- [1] IEC 825-1 (1993) Standard: *Safety of laser products, equipment classification, requirements and user's guide*.