



INTERNATIONAL TELECOMMUNICATION UNION

ITU-T

TELECOMMUNICATION
STANDARDIZATION SECTOR
OF ITU

G.824

(03/93)

DIGITAL NETWORKS

**THE CONTROL OF JITTER AND WANDER
WITHIN DIGITAL NETWORKS WHICH ARE
BASED ON THE 1544 kbit/s HIERARCHY**

ITU-T Recommendation G.824

(Previously "CCITT Recommendation")

FOREWORD

The ITU Telecommunication Standardization Sector (ITU-T) is a permanent organ of the International Telecommunication Union. The ITU-T is responsible for studying technical, operating and tariff questions and issuing Recommendations on them with a view to standardizing telecommunications on a worldwide basis.

The World Telecommunication Standardization Conference (WTSC), which meets every four years, established the topics for study by the ITU-T Study Groups which, in their turn, produce Recommendations on these topics.

ITU-T Recommendation G.824 was revised by the ITU-T Study Group XVIII (1988-1993) and was approved by the WTSC (Helsinki, March 1-12, 1993).

NOTES

1 As a consequence of a reform process within the International Telecommunication Union (ITU), the CCITT ceased to exist as of 28 February 1993. In its place, the ITU Telecommunication Standardization Sector (ITU-T) was created as of 1 March 1993. Similarly, in this reform process, the CCIR and the IFRB have been replaced by the Radiocommunication Sector.

In order not to delay publication of this Recommendation, no change has been made in the text to references containing the acronyms "CCITT, CCIR or IFRB" or their associated entities such as Plenary Assembly, Secretariat, etc. Future editions of this Recommendation will contain the proper terminology related to the new ITU structure.

2 In this Recommendation, the expression "Administration" is used for conciseness to indicate both a telecommunication administration and a recognized operating agency.

© ITU 1993

All rights reserved. No part of this publication may be reproduced or utilized in any form or by any means, electronic or mechanical, including photocopying and microfilm, without permission in writing from the ITU.

CONTENTS

	<i>Page</i>
1 Scope of the Recommendation.....	1
2 Network limits for maximum output at hierarchical interfaces and wander at synchronous network nodes .	1
2.1 Network limits for jitter	1
2.2 Network limits for wander.....	2
3 Framework for the specification of individual digital equipments.....	3
3.1 Basic specification philosophy	3
3.2 Digital line sections	6
3.3 Digital muldexes	6
3.4 Digital exchanges.....	6
4 Jitter and wander accumulation in digital networks	6
Annex A – Wander reference model for network nodes	7

THE CONTROL OF JITTER AND WANDER WITHIN DIGITAL NETWORKS WHICH ARE BASED ON THE 1544 kbit/s HIERARCHY

(Malaga-Torremolinos, 1984; amended at Melbourne, 1988 and Helsinki, 1993)

1 Scope of the Recommendation

In a transmission network jitter and wander accumulate according to the jitter and wander generation and transfer characteristics of each equipment interconnected. These equipments may be different types of multiplexers/demultiplexers and line systems.

An excessive amount of jitter and wander can adversely affect both digital (generation of bit errors, uncontrolled slips) and analogue signals (unwanted phase modulation of the transmitted signal). It is therefore necessary to set limits to the presence of jitter and wander at the network interfaces, in order to guarantee a proper quality of the transmitted signals.

The scope of this Recommendation is to define the parameters and the relevant values that are able to control satisfactorily the amount of jitter and wander present at plesiochronous digital hierarchies (PDH) network interfaces.

The Recommendation is applicable to networks adopting the digital hierarchy based on the first level bit rate of 1544 kbit/s. The electrical characteristics of the relevant network interfaces are described in Recommendation G.703.

The jitter control philosophy is based on the need:

- to recommend a maximum network limit that should not be exceeded at any hierarchical interface;
- to recommend a consistent framework for the specification of individual digital equipments;
- to provide sufficient information and guidelines for organizations to measure and study jitter accumulation in any network configuration.

2 Network limits for maximum output at hierarchical interfaces and wander at synchronous network nodes

2.1 Network limits for jitter

Specification of maximum permissible values of output jitter at hierarchical network interfaces is necessary to enable the interconnection of digital network components (line section, multiplex equipment, exchanges) to form a digital path or connection. These limits should be met regardless of the number of interconnected network components preceding the interface. The limits are intended to be compatible with the minimum jitter tolerance of all equipment operating at the same hierarchical level.

The limits given in Table 1 represent maximum permissible output jitter limits at hierarchical interfaces of a digital network. In circumstances where the maximum permissible jitter amplitude occurs at an interface between two countries, it is left to the discretion of national Administrations to take the appropriate remedial action. This situation is unlikely to occur very often.

For equipment which are not controlled by a network synchronizing system, but by an autonomous clock (e.g. quartz oscillator), more stringent output jitter values may be defined in the relevant equipment specifications. Examples are the muldex in Recommendation G.734 and concerning the primary rate access in Recommendation I.431.

The arrangements for measuring output jitter at a digital interface are illustrated in Figure 1. The specific jitter limits and values of filter cut-off frequencies are given in Table 1.

TABLE 1/G.824

Maximum permissible output jitter at hierarchical interfaces					
Digital rate (kbit/s)	Network limit (UI peak-to-peak)		Band-pass filter having a lower cut-off frequency f_1 or f_3 minimum upper cut-off frequency f_4		
	B_1	B_2	f_1 (Hz)	f_3 (kHz)	f_4 (kHz)
1 544	5.0	0.1 (Note)	10	8	40
6 312	3.0	0.1 (Note)	10	3	60
32 064	2.0	0.1 (Note)	10	8	400
44 736	5.0	0.1	10	30	400
97 728	1.0	0.05	10	240	1000

UI Unit Interval
 NOTE – This value requires further study.

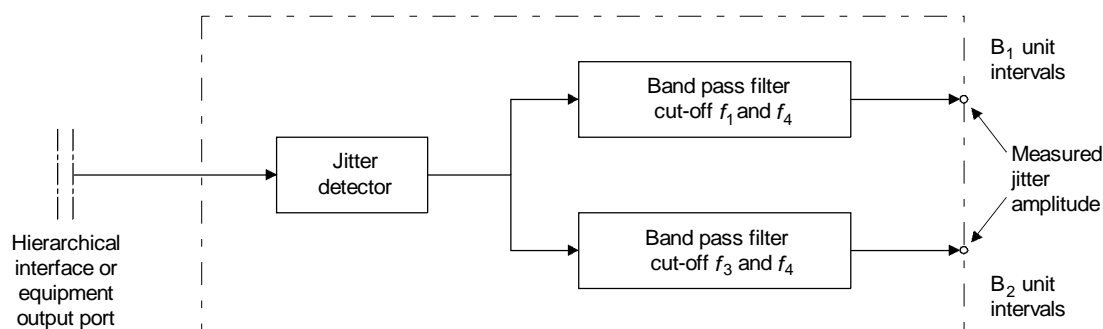

T1302200-93/d01

FIGURE 1/G.824

**Measurement arrangements for output jitter
 from a hierarchical interface or an equipment output port**

2.2 Network limits for wander

Network output wander specifications at synchronous network nodes are necessary to ensure satisfactory network performance (e.g. slips, error bursts). For network nodes the following limits are specified, based on the assumption of a non-ideal synchronizing signal (containing jitter, wander, frequency departure, and other impairments) on the line delivering timing information. The maximum time interval error (MTIE) (see Recommendation G.811) over a period of S seconds shall not exceed the following:

- 1) $S < 10^4$, this region requires further study;
- 2) $(10^{-2} S + 10\ 000)$ ns; applicable to values of S greater than 10^4 .

NOTES

1 The resultant overall specification is illustrated in Figure 2.

2 The full MTIE of 10 μ s, superimposed on the average timing, as specified above, may only occur at the output of the last node in a chain of nodes. This must be ensured by applying appropriate planning rules.

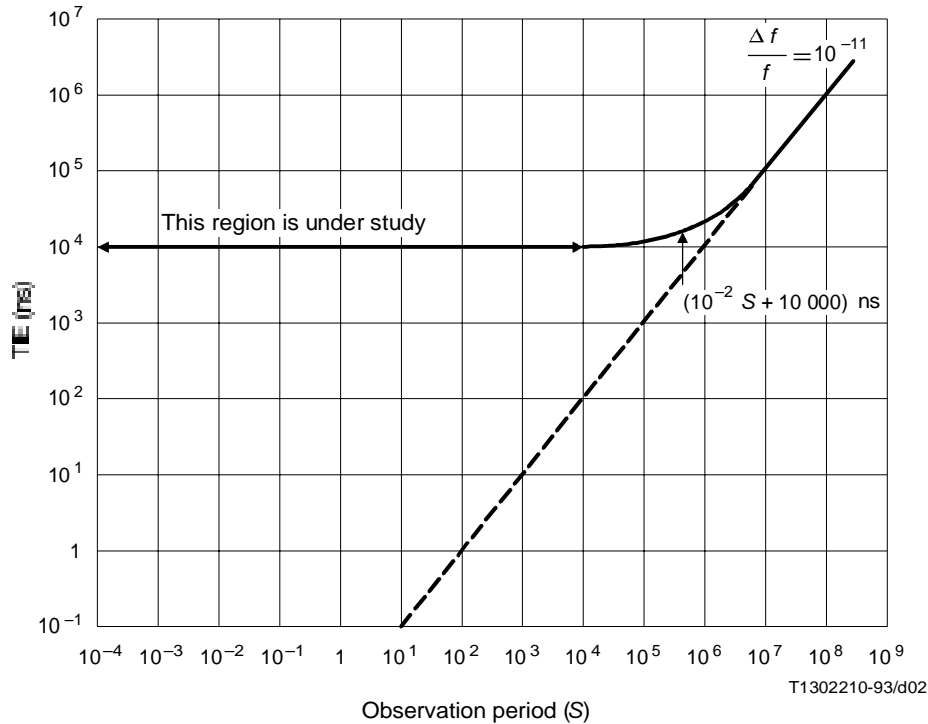

FIGURE 2/G.824

**Permissible maximum time interval error (MTIE)
versus observation period S for the output of a network node**

Further study is required to quantify the difference in limits for transit and local nodes. In addition, wander accumulation in networks is closely tied to the stability specifications contained in Recommendations G.811, G.812, Q.511.

3 Framework for the specification of individual digital equipments

3.1 Basic specification philosophy

Jitter and wander control inherently depends on both network and equipment design. Network considerations are discussed in 2. The principal parameters of importance when considering the jitter and wander performance of digital equipment are:

- i) the amount of jitter and wander that can be tolerated at the input;
- ii) the proportion of this input jitter and wander which filters through to the output; and
- iii) the amount of jitter and wander generated by the equipment.

The intention of this subclause is to provide a foundation for the development of equipment requirements which will ensure that the various network equipments are compatible from the standpoint of jitter and wander performance.

3.1.1 Jitter and wander tolerance of input ports

In order to ensure that any equipment will operate satisfactorily when connected to a hierarchical interface within the network, it is necessary that the equipment input ports be capable of accommodating levels of network output jitter up to the maximum network limits specified in Table 1. Specification of input jitter tolerance in terms of a single Recommendation applicable to all categories of digital equipment ensures that a certain minimum jitter tolerance is satisfied by all network elements. Most specifications of equipment input tolerance are in terms of the amplitude of sinusoidal jitter that can be applied at various frequencies without causing a designated degradation of error performance. The simplicity of this form of specification has great appeal, since it is easily verified with conventional test equipment. However, it is important to recognize that the test condition is not, in itself, intended to be representative of the type of jitter to be found in practice in a network. For some equipment, therefore, it may be necessary to specify supplemental jitter tolerance tests, and reference to the individual equipment Recommendation should always be made.

As a minimum guideline for equipment tolerance, it is recommended that all digital input ports of equipments be able to tolerate the sinusoidal jitter and wander defined by Figure 3 and Table 2. The limits are to be met in an operating environment.

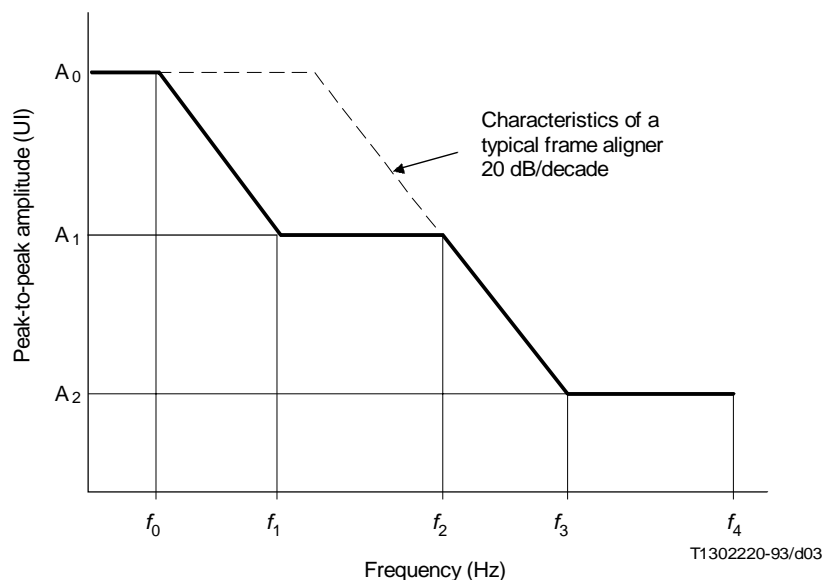

FIGURE 3/G.824

Mask of peak-to-peak jitter and wander which must be accommodated at the input of a node in a digital network

[Measurement method – refer to Supplement No. 3.8 (O-Series) and Supplement No. 35 (G-Series)]

The wander/jitter is superimposed upon a timing signal which is ideally synchronous with a reference clock, and in practice reasonably stable. Instrumentation in accordance with Recommendation O.171 is appropriate for measurement at jitter/wander frequencies above 2 Hz.

In deriving the specifications contained in Table 2 for frequencies above f_3 , the effects of the amount of alignment jitter of the equipment clock decision circuit are considered to be predominant. Measurements carried out to verify compliance with these specifications may provide environment dependent results, hence allowing some ambiguity in their interpretation. Account should be taken of the requirement at the design stage of the equipment; Supplement No. 3.8 (O-Series) provides guidance regarding environment independent measurements.

TABLE 2/G.824

Jitter and wander tolerance of input ports
(Provisional values)
 (Note 1)

Bit rates (kbit/s)	Jitter amplitude (peak-to-peak)			Frequency					Test signal
	A_0 (μ s)	A_1 (UI)	A_2 (UI)	f_0 (Hz)	f_1 (Hz)	f_2 (Hz)	f_3 (kHz)	f_4 (kHz)	
1 544	18 (Note 2)	5.0	0.1 (Note 2)	1.2×10^{-5}	10	120	6	40	$2^{20} - 1$ (Note 3)
6 312	18 (Note 2)	5.0	0.1	1.2×10^{-5}	10	50	2.5	60	$2^{20} - 1$ (Note 2)
32 064	18 (Note 2)	2.0	0.1	1.2×10^{-5}	10	400	8	400	$2^{20} - 1$ (Note 3)
44 736	18 (Note 2)	5.0	0.1 (Note 2)	1.2×10^{-5}	10	600	30	400	$2^{20} - 1$ (Note 2)
97 728	18 (Note 2)	2.0	0.1	1.2×10^{-5}	10	12 000	240	1000	$2^{23} - 1$ (Note 2)

NOTES

- 1 Reference to individual equipment specifications should always be made to check if supplementary input jitter tolerance requirements are necessary.
- 2 This value requires further study.
- 3 It is necessary to suppress long zero strings in the test sequence in networks not supporting 64 kbit/s transparency.
- 4 The value A_0 (18 μ s) represents a relative phase deviation between the incoming signal and the internal local timing signal derived from the reference clock.
- 5 The absolute phase deviation requires further study.
- 6 An example of a reference configuration explaining the A_0 value is given in Annex A.

In deriving these specifications, the wander effects are considered to be predominant at frequencies below f_1 , and many transmission equipments, such as digital line systems and asynchronous muldexes using justification techniques, are effectively transparent to these very low frequency changes in phase. However, such phase variation does need to be accommodated at the input of certain equipments (e.g. digital exchanges and synchronous muldexes). The requirement contained in Table 2 for frequencies below f_1 is not amenable to simple practical evaluation, but account should be taken of the requirement at the design stage of the equipment.

An input synchronizing a node and another not synchronizing the node may derive their respective timing from the same reference clock, but over different paths, and may therefore, in an extreme case, have opposite phase deviation. The expected maximum relative phase deviation is 18 μ s which must be accommodated by the equipment.

Equipment wander tolerance must be compatible with network output wander limits specified in Figure 2. Insufficient wander tolerance at synchronous equipment input ports may result in controlled or uncontrolled slips, depending on the specific slip control strategy employed.

3.1.2 Jitter and wander transfer characteristics

Jitter transfer characteristics define the ratio of output jitter to input jitter amplitude versus jitter frequency for a given bit rate. When jitter is present at the digital input port of digital equipment, in many cases some portion of the jitter is transmitted to the corresponding digital output port. Many types of digital equipment inherently attenuate the higher frequency jitter components present at the input. Recommendations dealing with particular equipment will ultimately define limiting values for its particular jitter transfer characteristics. To control jitter in cascaded homogeneous digital equipment situations, it is important to restrict the value of jitter gain.

Because the bandwidth of phase smoothing circuits in asynchronous digital equipment is generally above 10 Hz, wander on the input signal may appear virtually unattenuated on the output. However, in certain particular digital equipments (e.g. nodal clocks) it is necessary that wander be sufficiently attenuated from input to output. Recommendations dealing with synchronous equipment will ultimately define limiting values for particular wander transfer characteristics.

3.1.3 Intrinsic jitter and wander generation

Intrinsic jitter and wander generation is defined as output jitter and wander in the absence of input jitter and wander. It is necessary to restrict the amount of intrinsic jitter and wander generated within individual digital equipments to provide control over network jitter and wander accumulation from cascaded network elements. Limits for output jitter and wander for individual digital equipments are defined in the specific equipment Recommendations. The actual limits applied depend upon the type of equipment.

3.2 Digital line sections

To ensure that the maximum network limit (see 2.1) is not exceeded within a digital network, it is necessary to control the jitter and wander contributed by transmission systems.

The jitter specifications for digital line sections will ultimately be found in Recommendations G.911 to G.915.

3.3 Digital muldexes

To ensure that the maximum network limit (see 2.1) is not exceeded within a digital network, it is necessary to control the jitter and wander contributed by transmission systems.

The jitter specifications for digital muldexes using positive justification are found in Recommendations G.743 and G.752.

3.4 Digital exchanges

To ensure that the maximum network limit (to be specified in 2.2) is not exceeded within a digital network, it is necessary to control jitter and wander transfer and generation, as appropriate, for digital exchanges.

Output wander specifications for primary reference clocks are addressed in Recommendation G.811. The jitter and wander specifications for digital transit exchanges and digital local exchanges are found in Recommendation Q.541.

4 Jitter and wander accumulation in digital networks

The variability of network configurations presents a multitude of connection possibilities. To analyze a particular network configuration, it is necessary to use the information about the jitter characteristics of individual equipments in conjunction with appropriate jitter accumulation models. Supplement No. 36 G-Series provides information to aid organizations in carrying out such evaluations.

Annex A

Wander reference model for network nodes

(This annex forms an integral part of this Recommendation)

A wander reference model for network nodes explaining the A_0 value is given in Figure A.1.

Assumptions made in this model are as follows:

- maximum relative wander at the network nodes 18 μs ;
- MTIE of a primary reference clock 3 μs as in Recommendation G.811;
- MTIE at the output of a network node 10 μs as in Recommendation G.823 and this Recommendation;
- maximum relative wander in slave clocks 1 μs as in Recommendation G.812.

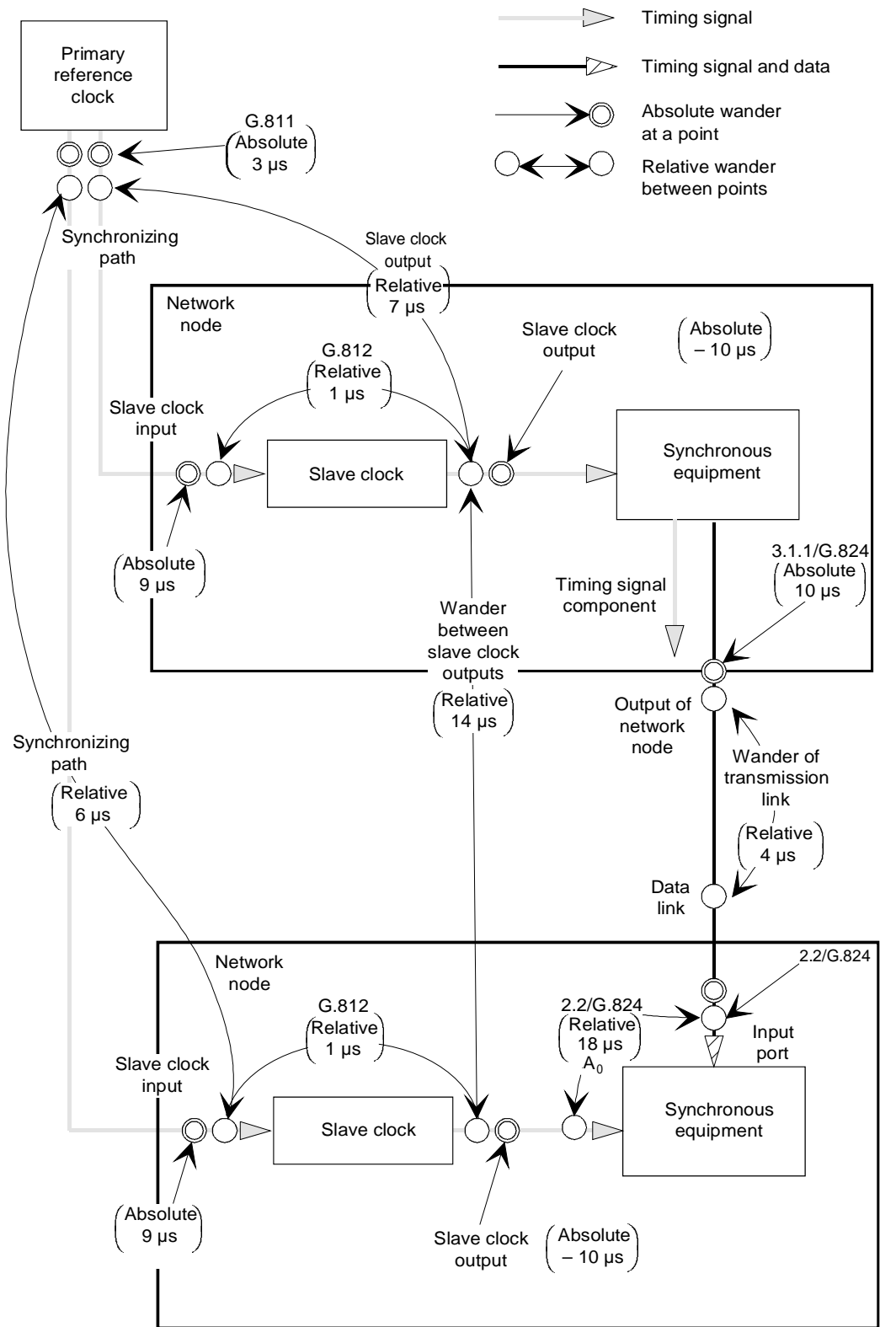

T1816990-92/d04

FIGURE A.1/G.824
Wander reference model