



INTERNATIONAL TELECOMMUNICATION UNION

**ITU-T**

TELECOMMUNICATION  
STANDARDIZATION SECTOR  
OF ITU

**G.805**

(11/95)

**DIGITAL NETWORKS**

---

**GENERIC FUNCTIONAL ARCHITECTURE  
OF TRANSPORT NETWORKS**

**ITU-T Recommendation G.805**

(Previously "CCITT Recommendation")

---

## FOREWORD

The ITU-T (Telecommunication Standardization Sector) is a permanent organ of the International Telecommunication Union (ITU). The ITU-T is responsible for studying technical, operating and tariff questions and issuing Recommendations on them with a view to standardizing telecommunications on a worldwide basis.

The World Telecommunication Standardization Conference (WTSC), which meets every four years, establishes the topics for study by the ITU-T Study Groups which, in their turn, produce Recommendations on these topics.

The approval of Recommendations by the Members of the ITU-T is covered by the procedure laid down in WTSC Resolution No. 1 (Helsinki, March 1-12, 1993).

ITU-T Recommendation G.805 was prepared by ITU-T Study Group 13 (1993-1996) and was approved under the WTSC Resolution No. 1 procedure on the 2nd of November 1995.

---

## NOTE

In this Recommendation, the expression "Administration" is used for conciseness to indicate both a telecommunication administration and a recognized operating agency.

© ITU 1996

All rights reserved. No part of this publication may be reproduced or utilized in any form or by any means, electronic or mechanical, including photocopying and microfilm, without permission in writing from the ITU.

# CONTENTS

		<i>Page</i>
1	Scope .....	1
2	References .....	1
3	Terms and definitions .....	1
4	Abbreviations .....	4
5	Functional architecture of transport networks .....	5
5.1	Introduction .....	5
5.2	Architectural components .....	5
5.2.1	Topological components .....	5
5.2.1.1	Layer network .....	5
5.2.1.2	Subnetwork .....	5
5.2.1.3	Link .....	6
5.2.1.4	Access Group .....	6
5.2.2	Transport entities .....	6
5.2.2.1	Link connection .....	6
5.2.2.2	Subnetwork connection .....	6
5.2.2.3	Network connection .....	6
5.2.2.4	Trail .....	6
5.2.3	Transport processing functions .....	7
5.2.3.1	Adaptation function .....	7
5.2.3.2	Trail termination function .....	7
5.2.4	Reference points .....	7
5.3	Partitioning and layering .....	7
5.3.1	Introduction .....	7
5.3.1.1	Application of the partitioning concept .....	7
5.3.1.2	Application of the layering concept .....	8
5.3.2	Partitioning concept .....	8
5.3.3	Layering concept .....	8
5.3.3.1	Client/server relationship .....	8
5.3.3.2	Transport layer networks .....	9
5.3.3.3	Decomposition of layer networks .....	9
5.3.3.3.1	General principles of decomposition of layers .....	9
5.3.3.3.2	Decomposition of the path layer network into specific path layer networks .....	9
5.3.3.3.3	Decomposition of the transmission media layer network into specific transmission media layers .....	9
5.3.3.3.4	Decomposition of specific layer networks into sublayers .....	10
5.3.4	Transport assembly .....	10
5.4	Connection supervision .....	10
5.4.1	Connection monitoring techniques .....	10
5.4.1.1	Inherent monitoring .....	10
5.4.1.2	Non-intrusive monitoring .....	10
5.4.1.3	Intrusive monitoring .....	10
5.4.1.4	Sublayer monitoring .....	11
5.4.2	Connection monitoring applications .....	11
5.4.2.1	Monitoring of unused connections .....	11
5.4.2.2	Tandem connection monitoring .....	11

	<i>Page</i>	
6	Application of concepts to network topologies and structures.....	11
6.1	PDH supported on SDH layer networks .....	11
6.2	ATM supported on SDH layer networks .....	12
7	Transport network availability enhancement techniques .....	12
7.1	Introduction .....	12
7.2	Protection.....	12
	7.2.1 Trail protection.....	12
	7.2.2 Subnetwork connection protection.....	13
	Appendix I – Formal description of the architecture.....	32
	I.1 General definitions.....	32
	I.2 Reference points .....	34
	I.3 Topological components.....	34
	I.4 Transport entities .....	36
	I.5 Transport processing functions.....	37
	Annex I.A – A short introduction to Z .....	37
	I.A.2 Example #1 .....	37
	I.A.3 Example #2 .....	38

## **SUMMARY**

This Recommendation describes the functional architecture of transport networks in a technology independent way. The generic functional architecture may be used as the basis for a harmonized set of functional architecture Recommendations for ATM, SDH, PDH transport networks, and a corresponding set of Recommendations for management, performance analysis and equipment specification.



# GENERIC FUNCTIONAL ARCHITECTURE OF TRANSPORT NETWORKS

(Geneva, 1995)

## 1 Scope

A telecommunications network is a complex network which can be described in a number of different ways depending on the particular purpose of the description. This Recommendation describes the network as a transport network from the viewpoint of the information transfer capability. More specifically, the functional and structural architecture of transport networks are described independently of networking technology.

This Recommendation describes the functional architecture of transport networks in a technology independent way. The generic functional architecture of transport networks should be taken as the basis for a harmonized set of functional architecture Recommendations for ATM, SDH, PDH networks, and a corresponding set of Recommendations for management, performance analysis and equipment specification.

## 2 References

The following Recommendations contain provisions which, through reference in this text, constitute provisions of this Recommendation. At the time of publication, the editions indicated were valid. All Recommendations are subject to revision: all users of this Recommendation are therefore encouraged to investigate the possibility of applying the most recent edition of the Recommendations. A list of the currently valid ITU-T Recommendations is regularly published.

- CCITT Recommendation G.702 (1988), *Digital Hierarchy bit rates*.
- CCITT Recommendation G.703 (1991), *Physical/electrical characteristics of hierarchical digital interfaces*.
- ITU-T Recommendation I.320 (1993), *ISDN protocol reference model*.
- CCITT Recommendation I.321 (1991), *B-ISDN protocol reference model and its applications*.
- CCITT Recommendation I.324 (1991), *ISDN network architecture*.
- CCITT Recommendation I.340 (1988), *ISDN connection types*.
- CCITT Recommendation X.200 (1988), *Reference model of Open Systems Interconnection for CCITT applications*.

## 3 Terms and definitions

### NOTES

1 The terms used here are specific to this Recommendation and should not be confused with the same terms used in, for example, Recommendations I.320, I.321, I.324 and I.340.

2 Where a definition contains a term which is itself defined, that term is given in quotation marks.

3 The terms can be further qualified by reference to a specific layer network by adding the appropriate layer network qualifier (e.g. SDH higher-order path termination, PDH 44 736 kbit/s path termination, ATM virtual path connection).

4 All architectural components are bidirectional unless qualified by the term sink or source or unidirectional.

**3.1 access group:** A group of co-located "trail termination" functions that are connected to the same "subnetwork" or "link".

**3.2 access point:** A "reference point" that consists of the pair of co-located "unidirectional access" points, and therefore represents the binding between the trail termination and adaptation functions.

- 3.3 unidirectional access point:** A “reference point” where the output of a “trail termination sink” is bound to the input of an “adaptation” sink or the output of an “adaptation” source function is bound to an input of a “trail termination source”.
- 3.4 adaptation:** A “transport processing function” that consists of a co-located adaptation source and sink pair.
- 3.5 adaptation sink:** A “transport processing function” which presents the client layer network characteristic information at its output by processing the information presented at its input by the server layer network trail.
- 3.6 adaptation source:** A “transport processing function” which accepts client layer network characteristic information at its input and processes it to allow transfer over a trail (in the server layer network).
- 3.7 architectural component:** Any item used in this Recommendation to generically describe transport network functionality.
- 3.8 binding:** A direct relationship between a “transport processing function” or “transport entity” and another “transport processing function” or “transport entity” which represents the static connectivity that cannot be directly modified by management action.
- 3.9 characteristic information:** A signal with a specific format, which is transferred on “network connections”. The specific formats will be defined in the technology specific Recommendations.
- 3.10 client/server relationship:** The association between layer networks that is performed by an “adaptation” function to allow the link connection in the client layer network to be supported by a trail in the server layer network.
- 3.11 connection:** A “transport entity” which consists of an associated pair of “unidirectional connections” capable of simultaneously transferring information in opposite directions between their respective inputs and outputs.
- 3.12 unidirectional connection:** A “transport entity” which transfers information transparently from input to output.
- 3.13 connection point:** A “reference point” that consists of a pair of co-located "unidirectional connection points", and therefore represents the binding of two paired bidirectional “connections”.
- 3.14 unidirectional connection point:** A “reference point” that represents the binding of the output of a “unidirectional connection” to the input of another “unidirectional connection”.
- 3.15 connection supervision:** The process of monitoring the integrity of a “connection” or “tandem connection” which is part of a “trail”.
- 3.16 layer network:** A “topological component” that includes both transport entities and transport processing functions that describe the generation, transport and termination of a particular characteristic information.
- 3.17 link:** A “topological component” which describes a fixed relationship between a “subnetwork” or “access group” and another “subnetwork” or “access group”.
- 3.18 link connection:** A “transport entity” that transfers information between “ports” across a link.
- 3.19 matrix:** It represents the limit to the recursive partitioning of a subnetwork.
- 3.20 matrix connection:** A “transport entity” that transfers information across a matrix, it is formed by the association of “ports” on the boundary of the matrix.
- 3.21 network:** All of the entities (such as equipment, plant, facilities) which together provide communication services.



- 3.22 network connection:** A transport entity formed by a series of contiguous “link connections” and/or “subnetwork connections” between “termination connection points”.
- 3.23 pairing:** A relationship between sink and source “transport processing functions” or two contra directional unidirectional “transport entities” or between “unidirectional reference points” which have been associated for the purposes of bidirectional transport.
- 3.24 path layer network:** A “layer network” which is independent of the transmission media and which is concerned with the transfer of information between path layer network “access points”.
- 3.25 port:** It consists of a pair of unidirectional ports.
- 3.26 unidirectional port:** It represents the output of a trail termination source or unidirectional link connection, or the input to a trail termination sink or unidirectional link connection.
- protection:**
- 3.27 dedicated protection:** A protection architecture that provides capacity dedicated to the protection of traffic-carrying capacity (1 + 1).
- 3.28 dual ended operation:** A protection operation method which takes switching action at both ends of the protected entity (e.g. “connection”, “path”), even in the case of a unidirectional failure.
- 3.29 shared protection:** A protection architecture using m protection entities shared amongst n working entities (m:n). The protection entities may also be used to carry extra traffic when not in use for protection.
- 3.30 single ended operation:** A protection operation method which takes switching action only at the affected end of the protected entity (e.g. “trail”, “subnetwork connection”), in the case of a unidirectional failure.
- 3.31 subnetwork connection protection:** A protection type that is modelled by a sublayer that is generated by expanding the “subnetwork” “connection point”.
- 3.32 trail protection:** A protection type that is modelled by a sublayer that is generated by expanding the “trail termination”.
- 3.33 reference point:** An architectural component, which is formed by the binding between inputs and outputs of transport processing functions and/or transport entities.
- 3.34 subnetwork:** A topological component used to effect routing of a specific characteristic information.
- 3.35 subnetwork connection:** A “transport entity” that transfers information across a subnetwork, it is formed by the association of “ports” on the boundary of the subnetwork.
- 3.36 tandem connection:** An arbitrary series of contiguous “link connections” and/or “subnetwork connections”.
- 3.37 termination connection point:** A reference point that consists of a pair of co-located unidirectional termination connection points, and therefore represents the binding of a trail termination to a bidirectional connection.
- 3.38 unidirectional termination connection point:** A reference point that represents the following bindings: output of a trail termination source to the input of a unidirectional connection or; the output of a unidirectional connection to the input of a trail termination sink.
- 3.39 topological component:** An architectural component, used to describe the transport network in terms of the topological relationships between sets of points within the same layer network.

- 3.40 trail:** A “transport entity” which consists of an associated pair of “unidirectional trails” capable of simultaneously transferring information in opposite directions between their respective inputs and outputs.
- 3.41 unidirectional trail:** A “transport entity” responsible for the transfer of information from the input of a trail termination source to the output of a trail termination sink. The integrity of the information transfer is monitored. It is formed by combining trail termination functions and a network connection.
- 3.42 trail management process:** Configuration of network resources during network operation for the purposes of allocation, re-allocation and routing of “trails” to provide “transport” to client networks.
- 3.43 trail termination:** A “transport processing function” that consists of a co-located trail termination source and sink pair.
- 3.44 trail termination sink:** A “transport processing function” which accepts the characteristic information of the layer network at its input, removes the information related to “trail” monitoring and presents the remaining information at its output.
- 3.45 trail termination source:** A “transport processing function” which accepts adapted “characteristic information” from a client layer network at its input, adds information to allow the “trail” to be monitored and presents the characteristic information of the layer network at its output. The trail termination source can operate without an input from a client layer network.
- 3.46 transmission media layer network:** A “layer network” which may be media dependent and which is concerned with the transfer of information between transmission media layer network “access points” in support of one or more “path layer networks”.
- 3.47 transport:** The functional process of transferring information between different locations.
- 3.48 transport assembly:** An arbitrary combination of contiguous layer networks and adaptation functions.
- 3.49 transport entity:** An architectural component which transfers information between its inputs and outputs within a layer network.
- 3.50 transport network:** The functional resources of the network which conveys user information between locations.
- 3.51 transport processing function:** An architectural component defined by the information processing which is performed between its inputs and outputs. Either the input or output must be inside a layer network; the corresponding output or input may be in the Management Network (e.g. output of a monitor function).

## 4 Abbreviations

For the purposes of this Recommendation, the following abbreviations are used.

AIS	Alarm Indication Signal
APS	Automatic Protection Switch
ATM	Asynchronous Transfer Mode
PDH	Plesiochronous digital hierarchy
SDH	Synchronous Digital Hierarchy
STM-N	Synchronous Transport Module (level) N
TCP	Termination Connection Point
VC-n	Virtual container (level) n

## **5 Functional architecture of transport networks**

### **5.1 Introduction**

The various functions which constitute a telecommunications network can be classified into two broad functional groups. One is the transport functional group which transfers any telecommunications information from one point to another point(s). The other is the control functional group which realizes various ancillary services and operations and maintenance functions. This Recommendation is concerned with the transport functional group.

A transport network transfers user information from one to another location bidirectionally or unidirectionally. A transport network can also transfer various kinds of network control information such as signalling and operations and maintenance information for the control functional group.

Since the transport network is a large, complex network with various components, an appropriate network model with well-defined functional entities is essential for its design and management. The transport network can be described by defining the associations between points in the network. In order to simplify the description, a transport network model, based on the concepts of layering and partitioning within each layer network is used in a manner which allows a high degree of recursiveness. It is recommended that this method is used for describing the transport network.

### **5.2 Architectural components**

The transport network has been analysed to identify generic functionality which is independent of implementation technology. This has provided a means to describe network functionality in an abstract way in terms of a small number of architectural components. These are defined by the function they perform in information processing terms or by the relationships they describe between other architectural components. In general the functions described here act on information presented at one or more inputs and present processed information at one or more outputs. They are defined and characterized by the information process between their inputs and outputs. The architectural components are associated together in particular ways to form the network elements from which real networks are constructed. The reference points of the transport network architecture are the result of binding the inputs and outputs of processing functions and transport entities.

Some diagrammatic conventions have been developed to support the descriptions which follow and these are illustrated in Figures 1 to 4.

#### **5.2.1 Topological components**

The topological components provide the most abstract description of a network in terms of the topological relationships between sets of like reference points. Four topological components have been distinguished; these are the layer network, the subnetwork, the link and the access group. Using these components it is possible to completely describe the logical topology of a layer network.

##### **5.2.1.1 Layer network**

A layer network is defined by the complete set of access groups of the same type which may be associated for the purpose of transferring information. The information transferred is characteristic of the layer network and is termed characteristic information. The associations of the trail terminations (that form a trail) in a layer network may be made and broken by a layer network management process thus changing its connectivity. A separate, logically distinct layer network exists for each trail termination type. The topology of a layer network is described by access groups, subnetworks and the links between them. The structures within and between layer networks are described by the components defined below.

##### **5.2.1.2 Subnetwork**

A subnetwork exists within a single layer network. It is defined by the set of ports which are available for the purpose of transferring characteristic information. The associations between the ports at the edge of a subnetwork may be made and broken by a layer network management process thus changing its connectivity. When a subnetwork connection is established the reference points are also created by binding the ports to input and output of the subnetwork connection. In general, subnetworks may be partitioned into smaller subnetworks interconnected by links; this is described in Section 5.3.2. The matrix is a special case of a subnetwork that cannot be further partitioned.

### **5.2.1.3 Link**

A link consists of a subset of the ports at the edge of one subnetwork or access group which are associated with a corresponding subset of the ports at the edge of another subnetwork or access group for the purpose of transferring characteristic information. The link represents the topological relationship and available transport capacity between a pair of subnetworks, or a subnetwork and an access group or a pair of access groups. Multiple links may exist between any given subnetwork and access group or pair of subnetworks or access groups. Links are established and maintained by the server layer network.

### **5.2.1.4 Access Group**

An access group is a group of co-located trail termination functions that are connected to the same subnetwork or link.

## **5.2.2 Transport entities**

The transport entities provide transparent information transfer between layer network reference points. There is no information change between input and output other than that resulting from degradation in the transfer process.

Two basic entities are distinguished according to whether the information transferred is monitored for integrity. These are termed connections and trails. Connections are further distinguished into network connections, subnetwork connections and link connections according to the topological component to which they belong.

### **5.2.2.1 Link connection**

A link connection is capable of transferring information transparently across a link. It is delimited by ports and represents the fixed relation between the ends of the link. A link connection represents a pair of adaptation functions and a trail in the server layer network.

The port at the input to a unidirectional link connection also represents the input to an adaptation source, the port at the output of a unidirectional link connection also represents the output of an adaptation sink. The unidirectional link connections and the associated ports and adaptation sink and source may be paired to provide bidirectional information transfer.

### **5.2.2.2 Subnetwork connection**

A subnetwork connection is capable of transferring information transparently across a subnetwork. It is delimited by connection points at the boundary of the subnetwork and represents the association between these connection points. When a subnetwork connection is established, the reference points are also created by binding the ports to input and output of the subnetwork connection. In general subnetwork connections are constructed from a concatenation of subnetwork connections and link connections. The matrix connection is a special case of the subnetwork connection that is formed by a single (indivisible) subnetwork connection.

### **5.2.2.3 Network connection**

A network connection is capable of transferring information transparently across a layer network. It is delimited by Termination Connection Points (TCPs). It is formed from a concatenation of subnetwork connections and/or link connections. The TCP is formed by binding the port of the trail termination to either a subnetwork connection or the port of a link connection. There is no explicit information to allow the integrity of the transferred information to be monitored. Some techniques that allow the integrity to be monitored are described in 5.4.

### **5.2.2.4 Trail**

A trail represents the transfer of monitored adapted characteristic information of the client layer network between access points. It is delimited by two access points, one at each end of the trail. It represents the association between the ends of the trail. A trail is formed by associating trail terminations with a network connection.

### **5.2.3 Transport processing functions**

Two generic processing functions of adaptation and trail termination are distinguished in describing the architecture of layer networks.

#### **5.2.3.1 Adaptation function**

Adaptation source: A transport processing function which adapts the client layer network characteristic information into a form suitable for transport over a trail in the server layer network.

Adaptation sink: A transport processing function which converts the server layer network trail information into the characteristic information of the client layer network

Adaptation: A transport processing function that consists of a co-located adaptation source and sink pair.

The following are examples of processes which may occur singly or in combination in an adaptation function; coding, rate changing, aligning, justification, multiplexing.

#### **5.2.3.2 Trail termination function**

Trail termination source: a transport processing function which accepts adapted characteristic information from a client layer network at its input, adds information to allow the trail to be monitored and presents the characteristic information of the layer network at its output. The trail termination source can operate without an input from a client layer network.

Trail termination sink: a transport processing function which accepts the characteristic information of the layer network at its input, removes the information related to trail monitoring and presents the remaining information at its output.

Bidirectional Trail termination: a transport processing function that consists of a pair of co-located trail terminations source and sink functions.

### **5.2.4 Reference points**

Reference points are formed by the binding between inputs and outputs of transport processing functions and/or transport entities. The allowable bindings and resultant specific types of reference points are shown in Figure 4. The connection types supported by these reference points are also shown in Figure 4.

## **5.3 Partitioning and layering**

### **5.3.1 Introduction**

A transport network can be decomposed into a number of independent transport layer networks with a client/server association between adjacent layer networks. Each layer network can be separately partitioned in a way which reflects the internal structure of that layer network or the way that it will be managed. Thus the concepts of partitioning and layering are orthogonal as shown in Figure 5.

#### **5.3.1.1 Application of the partitioning concept**

The partitioning concept is important as a framework for defining:

- a) the network structure within a layer network;
- b) administrative boundaries between network operators jointly providing connections within a single layer network;
- c) domain boundaries within a layer network of a single operator to allow the apportioning of performance objectives to the architectural components;
- d) routing domain boundaries within the layer network of a single operator;
- e) the part of a layer network or subnetwork that is under the control of a third party for routing purposes (e.g. customer network management).

### 5.3.1.2 Application of the layering concept

The layering concept of the transport network allows:

- a) each layer network to be described using similar functions;
- b) the independent design and operation of each layer network;
- c) each layer network to have its own operations, diagnostic and automatic failure recovery capability;
- d) the possibility of adding or modifying a layer network without affecting other layer networks from the architectural viewpoint;
- e) simple modelling of networks that contain multiple transport technologies.

### 5.3.2 Partitioning concept

In general a subnetwork is constructed by representing the physical implementation as links and subnetworks, starting from the matrix that is the smallest (indivisible) subnetwork. A set of subnetworks and links may be abstracted as a higher (containing) subnetwork. The way in which the contained subnetworks are interconnected by links describes the topology of the containing subnetwork. The ports at the boundary of the containing subnetwork and the interconnection capability must fully represent, but not extend, the connectivity supported by the contained subnetworks and links. Therefore a higher level subnetwork may be partitioned to show the level of detail required.

Thus in general, any subnetwork may be partitioned into a number of smaller (contained) subnetworks interconnected by links. The partitioning of a subnetwork cannot extend or restrict its connectivity i.e.:

- The ports on the boundary of the containing subnetwork and the interconnection capability must be represented by the contained subnetworks and links.
- The contained subnetworks and links cannot provide connectivity that is not available in the containing subnetwork.

Examples of subnetworks are the international portion and the national portions of a layer network, which can be further divided into transit portions and access portions and so on as shown in Figure 6.

A network connection or subnetwork connection may be decomposed into a concatenation of other transport entities (link or subnetwork connection) which reflects the partitioning of a subnetwork. This is illustrated in Figures 7 and 8.

### 5.3.3 Layering concept

The transport network can be decomposed into a number of independent layer networks with a client/server relationship between adjacent layer networks. A layer network describes the generation, transport and termination of a particular characteristic information.

The layer networks which have been identified in the transport network functional model should not be confused with the layers of the OSI Model (Recommendation X.200). An OSI layer offers a specific service using one protocol among different protocols. On the contrary, each layer network (in this Recommendation) offers the same service using a specific protocol (the characteristic information).

The relationship between partitioning and layering is illustrated in Figure 8.

#### 5.3.3.1 Client/server relationship

The client/server relationship between adjacent layer networks is one where a link connection in the client layer network is supported by a trail in the server layer network.

The concept of adaptation is introduced to describe how the client layer network characteristic information is modified so that it can be transported over a trail in the server layer network. From a transport network functional viewpoint therefore the adaptation function falls between the layer networks. All the reference points belonging to a single layer network can be visualized as lying on a single plane as illustrated in Figure 2. (Example Layer Network bounded by access groups.) This is the reason why there is not the same concept of contiguous layer boundaries in the transport network model as in the OSI protocol reference model.

### **5.3.3.2 Transport layer networks**

The transport functional group may be classified broadly into two classes of layer network: a path layer network and a transmission media layer network:

- Path layer network – provides the information transfer capability required to support various types of services. Path layer networks are independent of transmission media layer networks. The description of the path layer network is the main application of this Recommendation.
- Transmission media layer network – is supported by trails and link connections, subnetwork connections are not provided. A transmission media layer network may be dependent on the physical media used for transmission such as optical fibre and radio.

### **5.3.3.3 Decomposition of layer networks**

#### **5.3.3.3.1 General principles of decomposition of layers**

It is possible to decompose a layer network by expanding either the trail terminations, or (termination) connection points of the layer network.

#### **5.3.3.3.2 Decomposition of the path layer network into specific path layer networks**

It is possible to identify a set of specific path layer networks within the path layer network which are likely to be independently managed by a network operator.

Each specific path layer network may have both the information transfer capability required to support various types of services and other specific path layer networks as clients and can have the transmission media layer network or other specific path layer networks as servers. The actual decomposition used to generate the specific path layer networks is dependent on the technology. Each specific path layer network can have independent topology and it is likely that paths across a specific path layer network will be set up independently from the setup of paths in other specific path layer networks. Examples of the decomposition of the path layer network are given in clause 6.

#### **5.3.3.3.3 Decomposition of the transmission media layer network into specific transmission media layers**

It is possible to identify a set of layer networks within the transmission media layer network which are likely to be independently administered by a network operator by decomposing the transmission media layer network. The connectivity of a transmission media layer network cannot be directly modified by management action. Transmission media layer networks are divided into section layer networks and physical media layer networks.

Section layer networks are concerned with all the functions which provide for the transfer of information between locations in path layer networks. The section layer network may be decomposed into specific section layer networks as described in the examples in clause 6.

Physical media layer networks are concerned with the actual fibres, metallic wires or radio frequency channels which support a section layer network. The physical media layer network may be decomposed into specific physical media layer networks to represent, for example, wave division multiplexing. Since a server layer network does not exist for the lowest layer network (e.g. the physical media layer network) the network connection is directly supported by the media and not by a trail.

Advances in the technologies available to implement the transmission media layer network may at some time in the future allow the connectivity of the transmission media layer to be modified by management action. The modelling of this capability is for further study.

#### 5.3.3.3.4 Decomposition of specific layer networks into sublayers

It is often useful to distinguish sublayers within a specific layer network. This can be done by decomposing the specific layer network into sublayers by expanding the trail termination or connection point. Example applications include:

- identification of sublayer protection schemes (see clause 7) by the expansion of the trail termination;
- identification of a sublayer describing a trail which monitors a tandem connection by decomposing the trail termination;
- identification of sublayer protection schemes (see clause 7) by the expansion of the connection point.

The expansion of the trail termination and connection point is illustrated in Figure 9. The concept of sublayers is illustrated in Figure 10. This procedure has been used in developing functional models for protection and tandem connection monitoring.

#### 5.3.4 Transport assembly

For the description of technology dependent transport architecture, it is useful to associate a set of contiguous layer networks and adaptation functions.

### 5.4 Connection supervision

#### 5.4.1 Connection monitoring techniques

##### 5.4.1.1 Inherent monitoring [refer to Figure 12 a)]

Connections may be indirectly monitored by using the data that is inherently available from the server layer network. If the trail in a server layer network fails then it may provide an indication (e.g. AIS) at the output of the link connections that are being supported.

The trail in the server layer network may also provide some error performance information about a single link connection. When the adaptation function includes multiplexing, the error performance statistics for each of the link connections, supported by the server layer trail, will not be available individually; it must be estimated from the error performance of the trail. The information from each link connection that forms the overall connection of interest may be collected and correlated via a management network. The overall status of the connection cannot be provided by this technique since the adaptation functions and matrix connections are not included in the monitoring scheme.

##### 5.4.1.2 Non-intrusive monitoring [refer to Figure 12 b)]

The connection may be directly monitored by use of listen-only (non-intrusive) monitoring of the original characteristic information. The information derived from this monitor reflects the status of the connection from the original trail termination source to the connection point at which the monitor is attached. The status of a particular part of a connection may be derived by correlating, via the management network, the results obtained from non-intrusive monitors attached to the connection points that delimit the segment. This status may include both the error performance and connectivity of the segment if the original signal was provided with a unique identifier signal. This correlation technique will support arbitrary nesting or overlapping of connection segments.

##### 5.4.1.3 Intrusive monitoring [refer to Figure 12 c)]

A connection may be directly monitored by breaking the original trail and introducing a test trail that extends over the part of the connection of interest for the duration of the test.

In this way all parameters can be monitored directly, but the user trail is interrupted so this can only be done either just at the beginning of the trail setup, or possibly in an intermittent fashion.

This technique supports arbitrary nesting or overlapping of the connections, but not simultaneous testing.



#### 5.4.1.4 Sublayer monitoring [refer to Figure 12 d)]

Some portion of the original trail's capacity<sup>1)</sup> is over-written such that the part of the connection that is of interest can be directly monitored by a trail created in a sublayer.

With this technique all parameters can be tested directly, assuming that sufficient bandwidth can be over-written in the original capacity. This scheme is unlikely to be able to support overlapping or nested connections.

### 5.4.2 Connection monitoring applications

#### 5.4.2.1 Monitoring of unused connections

A connection is unused if one of the ports that delimit the connection is not involved in a binding relationship. An unused connection may be monitored by using a supervisory trail termination source (that provides minimum client layer overhead required for monitoring) in combination with a non-intrusive monitor as shown in Figure 13.

#### 5.4.2.2 Tandem connection monitoring

A tandem connection represents the part of a trail that requires monitoring independently from the monitoring of the complete trail. In this role, the following functions may be required by the tandem connection (refer to Figure 12):

- tandem connection performance monitoring (error performance and failure/alarm conditions);
- tandem connection far end performance monitoring (error performance and failure/alarm conditions);
- tandem connection incoming failure indication (failures before the tandem connection);
- tandem connection connectivity verification (i.e. trace) (between the ends of the tandem connection);
- tandem connection idle signal (including idle signal identity).

The application and terminology for tandem connections is provided in Figure 11.

## 6 Application of concepts to network topologies and structures

### 6.1 PDH supported on SDH layer networks

Figure 14 shows an example of the case where PDH signals are supported on SDH. Five layer networks are shown:

- a) PDH G.702 path (e.g. 2048 kbit/s) layer network;
- b) PDH G.703 intra-office section layer network;
- c) SDH lower-order path (e.g. VC-12) layer network;
- d) SDH higher-order path (e.g. VC-4) layer network;
- e) SDH STM-N section layer network.

The example shows two SDH multiplexers with tributaries at the PDH path bit rates interconnected with a SDH lower-order path cross-connect and a SDH higher-order path cross-connect at intermediate locations. All interfacing (except the tributaries at the PDH path bit rates) uses the SDH STM-N section layer.

---

<sup>1)</sup> In networks based on SDH or PDH the capacity over-written must be part of the trail overhead; in networks based on ATM OAM cells may be inserted.

## 6.2 ATM supported on SDH layer networks

Figure 15 shows an example of the case where ATM cells are supported on SDH. Four layer networks are shown:

- a) ATM virtual channel layer network;
- b) ATM virtual path layer network;
- c) SDH higher-order path (e.g. VC-4) layer network;
- d) SDH STM-N section layer network.

The example shows two ATM virtual channel terminations interconnected with an ATM virtual channel switch/cross-connect and two ATM virtual path terminations interconnected with an ATM virtual path switch/cross-connect and a SDH higher-order path cross-connect at intermediate locations. All interfacing uses the SDH STM-N section layer network.

## 7 Transport network availability enhancement techniques

### 7.1 Introduction

This clause describes the architectural features of the main strategies which may be used to enhance the availability of a transport network. This enhancement is achieved by the replacement of failed or degraded transport entities. The replacement is normally initiated by the detection of a defect, performance degradation or an external (e.g. network management) request.

**Protection** – This makes use of pre-assigned capacity between nodes. The simplest architecture has one dedicated protection entity for each working entity ( $1 + 1$ ). The most complex architecture has  $m$  protection entities shared amongst  $n$  working entities ( $m:n$ ). Protection may be either dual ended or single ended. Dual ended protection takes switching action at both ends of the protected entity (e.g. connection, path), even when the failure is unidirectional. Single ended protection only takes action at the affected end of the protected entity in the case of a unidirectional failure.

**Restoration** – This makes use of any capacity available between nodes. In general the algorithms used for restoration will involve re-routing. When restoration is used some percentage of the transport network capacity will be reserved for re-routing of working traffic. Further description of restoration is not within the scope of this Recommendation.

### 7.2 Protection

Two types of protection architecture have been identified.

#### 7.2.1 Trail protection

A working trail is replaced by a protecting trail if the working trail fails or if the performance falls below the required level. This is modelled by introducing a protection sublayer as shown in Figure 16. The trail termination is expanded, according to the rules given in Figure 9, by introducing the protection adaptation function, unprotected trail termination function and protected trail termination function. A protection matrix is used to model the switching between the protecting and working connections. The status of the trails in the protection sublayer is made available to the protection matrix (trail signal fail in Figure 16) by the unprotected trail termination. If communication between the control functions of the protection matrices is required, the protection adaptation function may provide access to an Automatic Protection Switch (APS) channel. The protected trail termination provides the status of the protected trail.

Trail protection is a protection method applied in a transport layer network when a defect condition is detected in the same layer network (i.e. switching is activated in the same transport layer network).

### **7.2.2 Subnetwork connection protection**

A working (sub)network connection is replaced by a protecting (sub)network connection if the working (sub)network connection fails or if the performance falls below the required level. It is a protection switching method applied in the client layer network when a defect condition is detected in a server layer network, sublayer or other transport layer network.

Note that (sub)network connection protection may be applied to any layer network; also the (sub)network connection being protected may be made up of a sequence of lower level subnetwork connections and link connections. (Sub)network connection protection schemes can be characterized by the monitoring method used to derive the switching criteria:

- Sublayer trail monitoring – (Sub)network connection protection can be modelled by a protection sublayer generated by expanding the subnetwork connection points, according to the rules given in Figure 9. The introduction of a sublayer results in a trail protection of the sublayer trail. This is illustrated in Figure 17.
- Inherent monitoring – The information derived by the server layer network as described in Section 5.4.1.1, is used to initiate protection switching. This is illustrated in Figure 18. The status of the trails in the server layer network are made available to the matrix (server signal fail in Figure 18).
- Non-intrusive monitoring – The (sub)network connection is directly monitored by use of listen-only (non-intrusive) monitoring of the client layer characteristic information as illustrated in Figure 19.
- Intrusive monitoring – Use of this type of monitor is not recommended as part of a protection scheme.

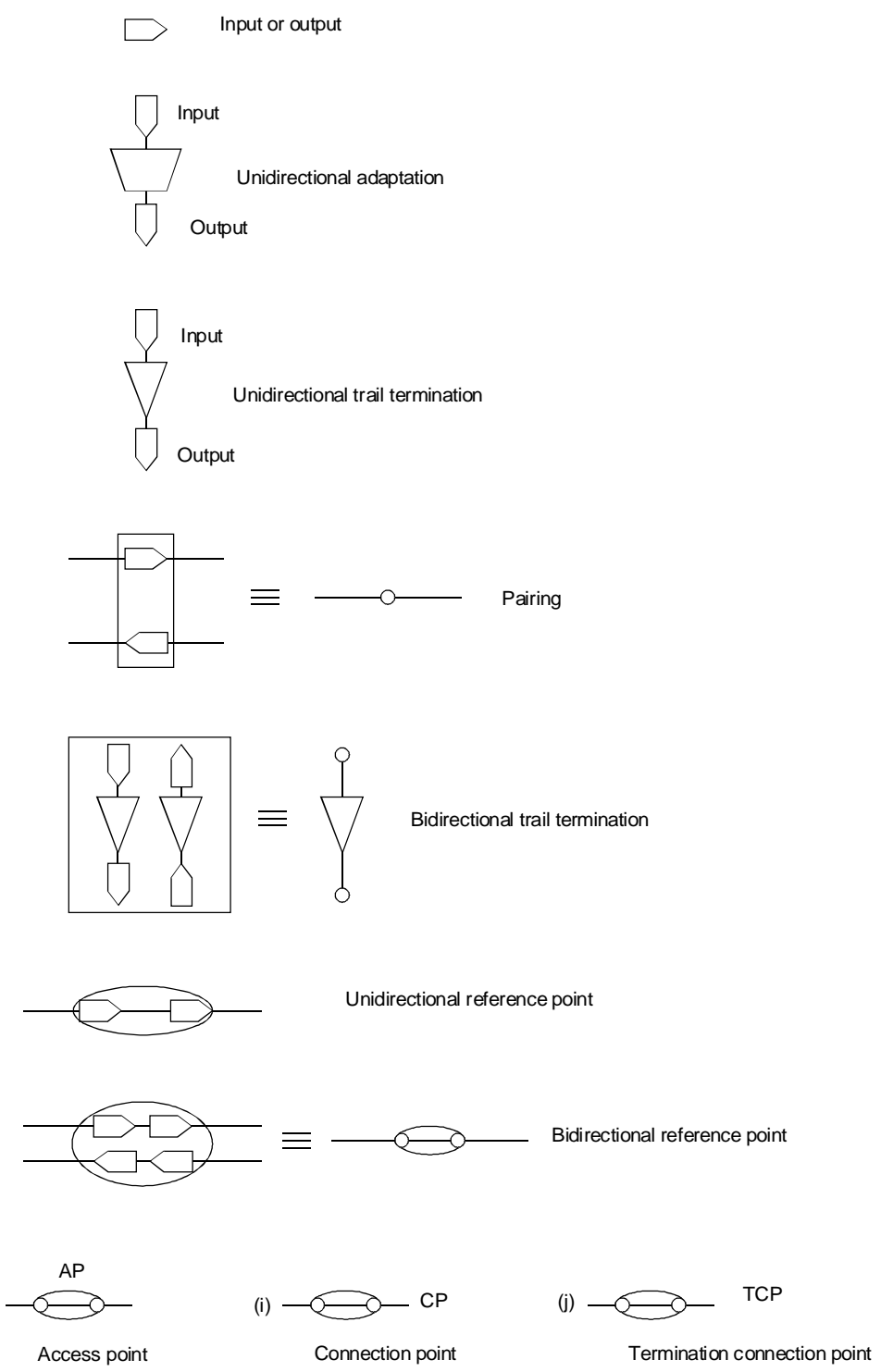

T1304450-95/d01

FIGURE 1/G.805  
**Diagrammatic conventions for processing functions and reference points**

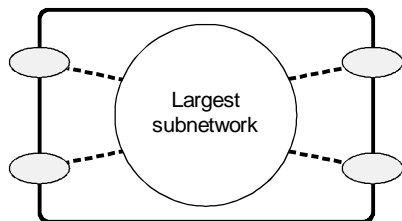
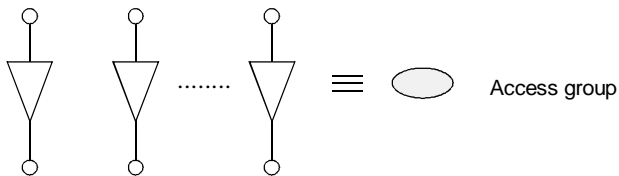
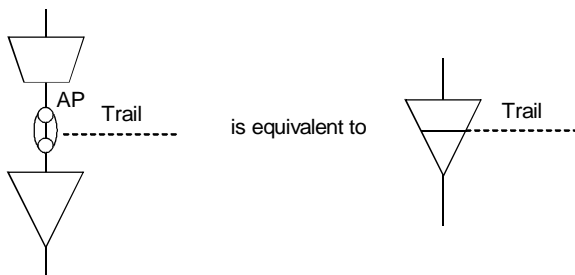
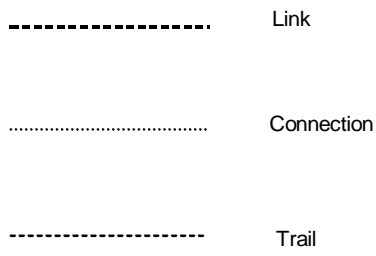

Example layer network bounded by access groups

T1304460-95/d02

FIGURE 2/G.805  
Other diagrammatic conventions

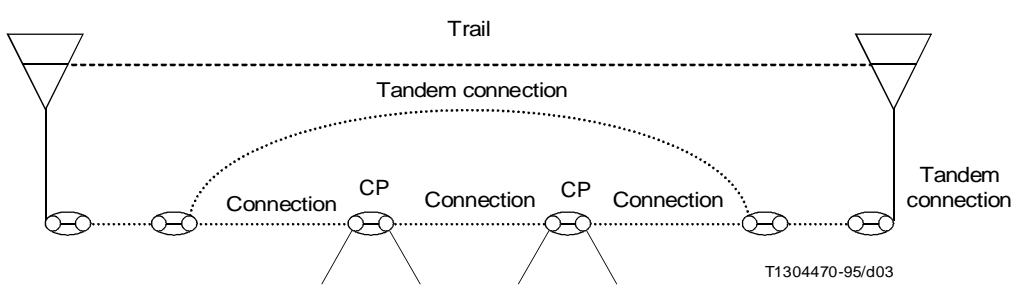
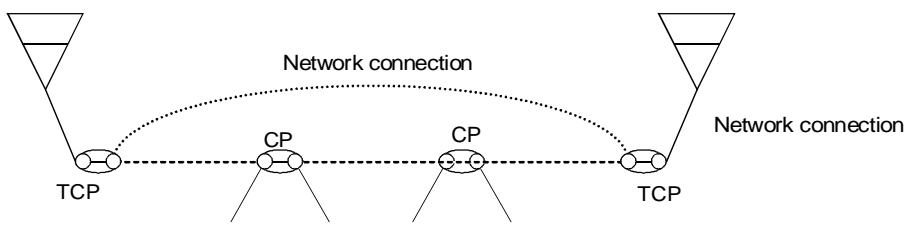
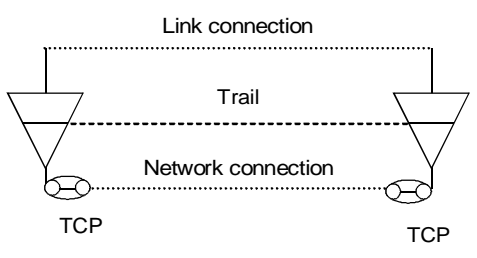
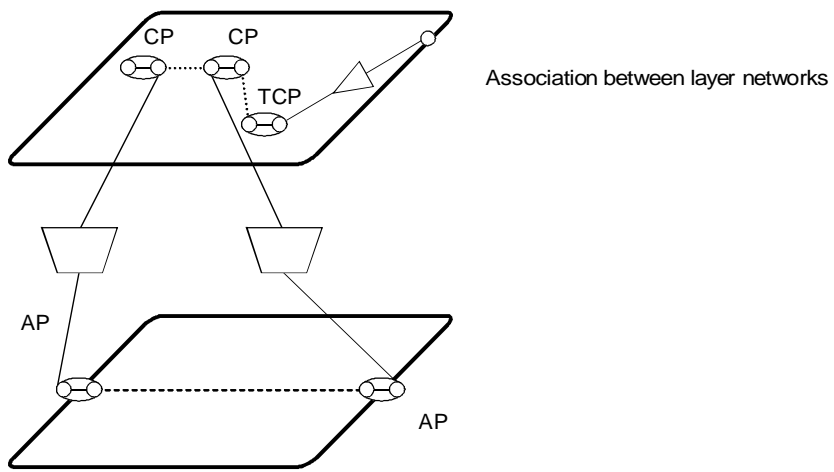

T1304470-95/d03

FIGURE 2/G.805 (concluded)  
Other diagrammatic conventions

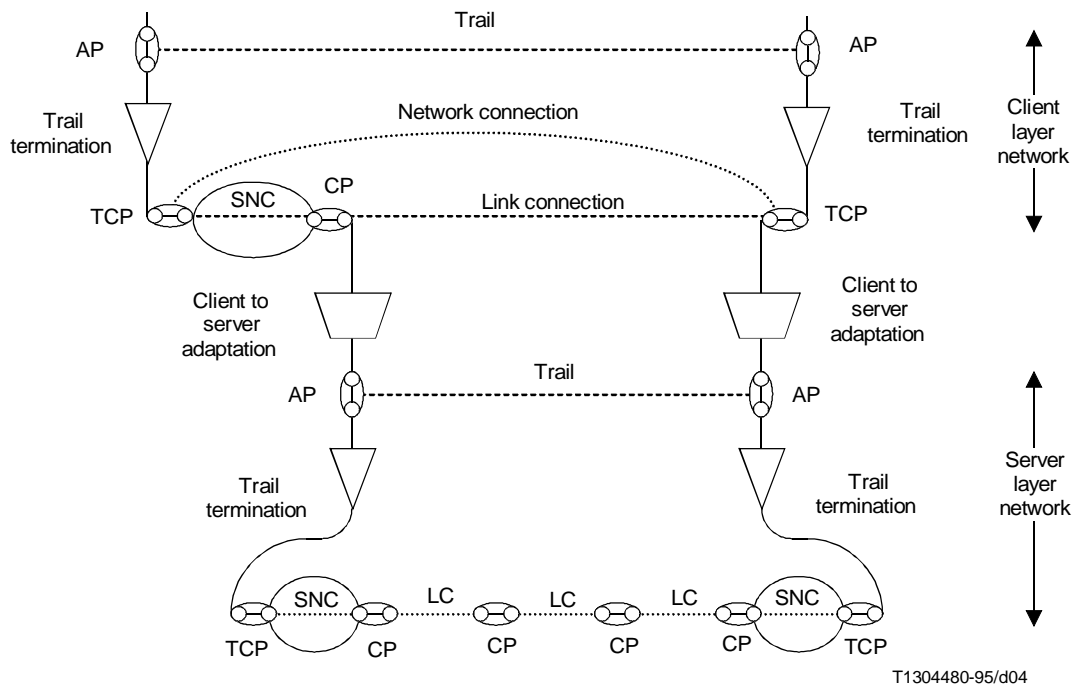

FIGURE 3/G.805  
**Example functional model**

Architectural component				Reference point	
Adaptation	Source output	Trail term	Source input	AP	uni
	Sink input		Sink output		uni
	pair		Source/sink pair		bi
Trail term	Source output (port)	LC	uni input (port)	TCP	uni
	Sink input (port)		uni output (port)		uni
	pair		pair		bi
Trail term	Source output (port)	SNC	uni input	TCP	uni
	Sink input (port)		uni output		uni
	pair		pair		bi
LC	uni input (port)	SNC	uni output	CP	uni
	uni output (port)		uni input		uni
	pair		pair		bi
LC	uni input (port)	LC	uni output (port)	CP	uni
	uni output (port)		uni input (port)		uni
	pair		pair		bi
Adaptation	Source input	adaptation	Sink output	CP	uni
	Sink output		Source input		uni
	pair		pair		bi

AP	Access Point	TCP	Termination Connection Point
bi	bidirectional	Trail term	Trail termination
LC	Link Connection	uni	unidirectional
SNC	Subnetwork connection		

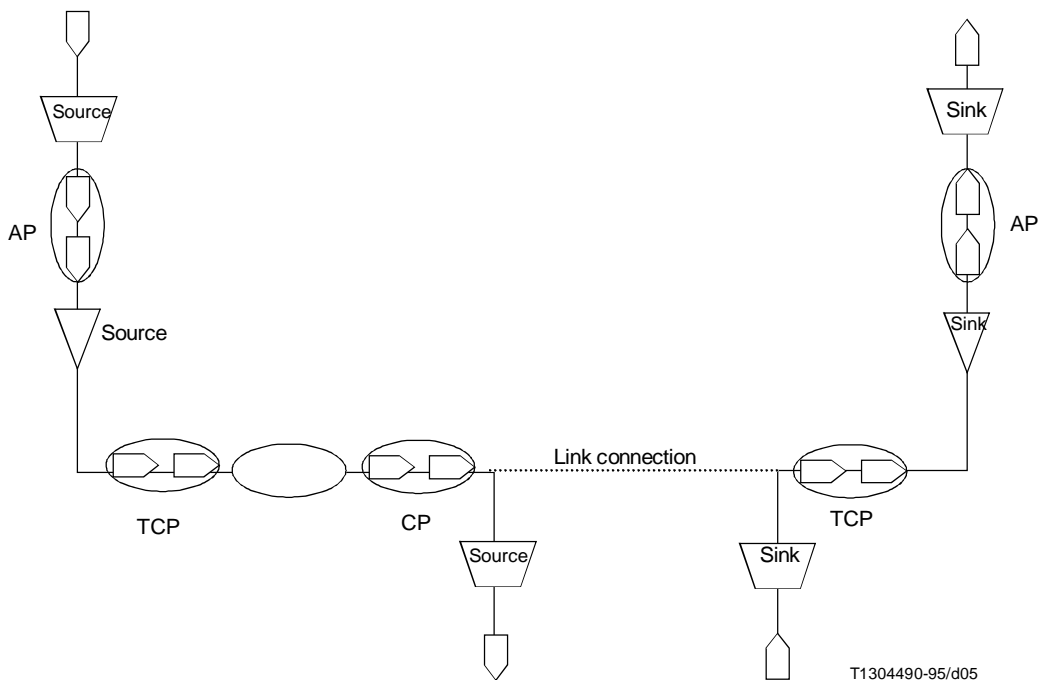

FIGURE 4/G.805  
**Bindings and types of reference points**



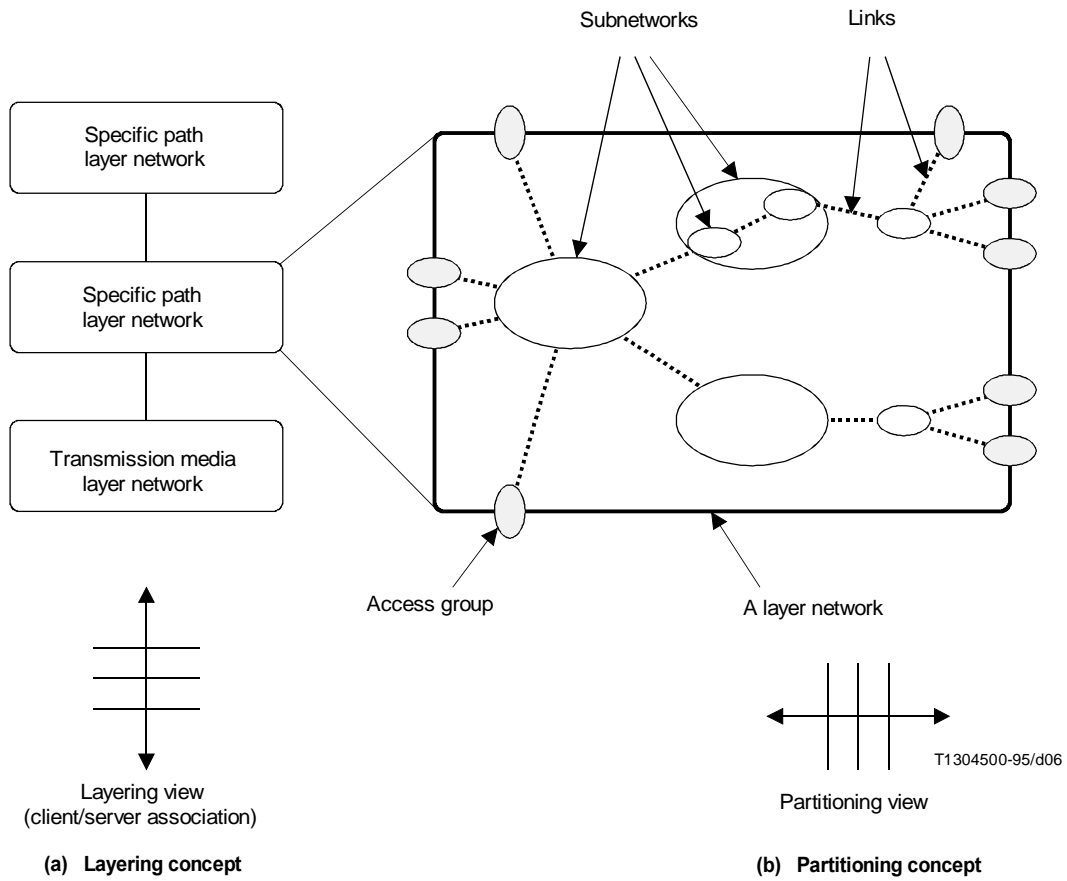

FIGURE 5/G.805  
**Orthogonal views of layering and partitioning**

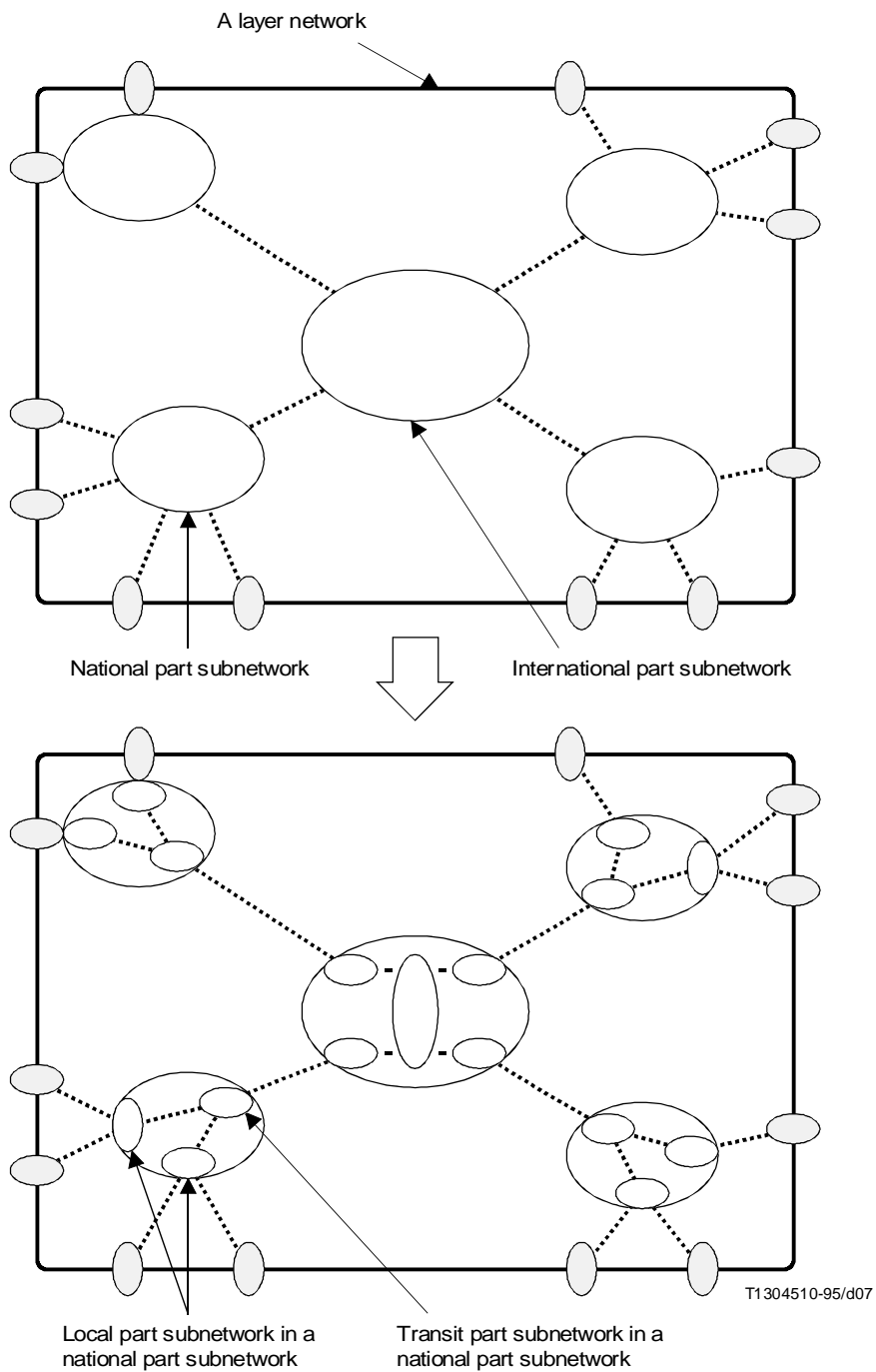
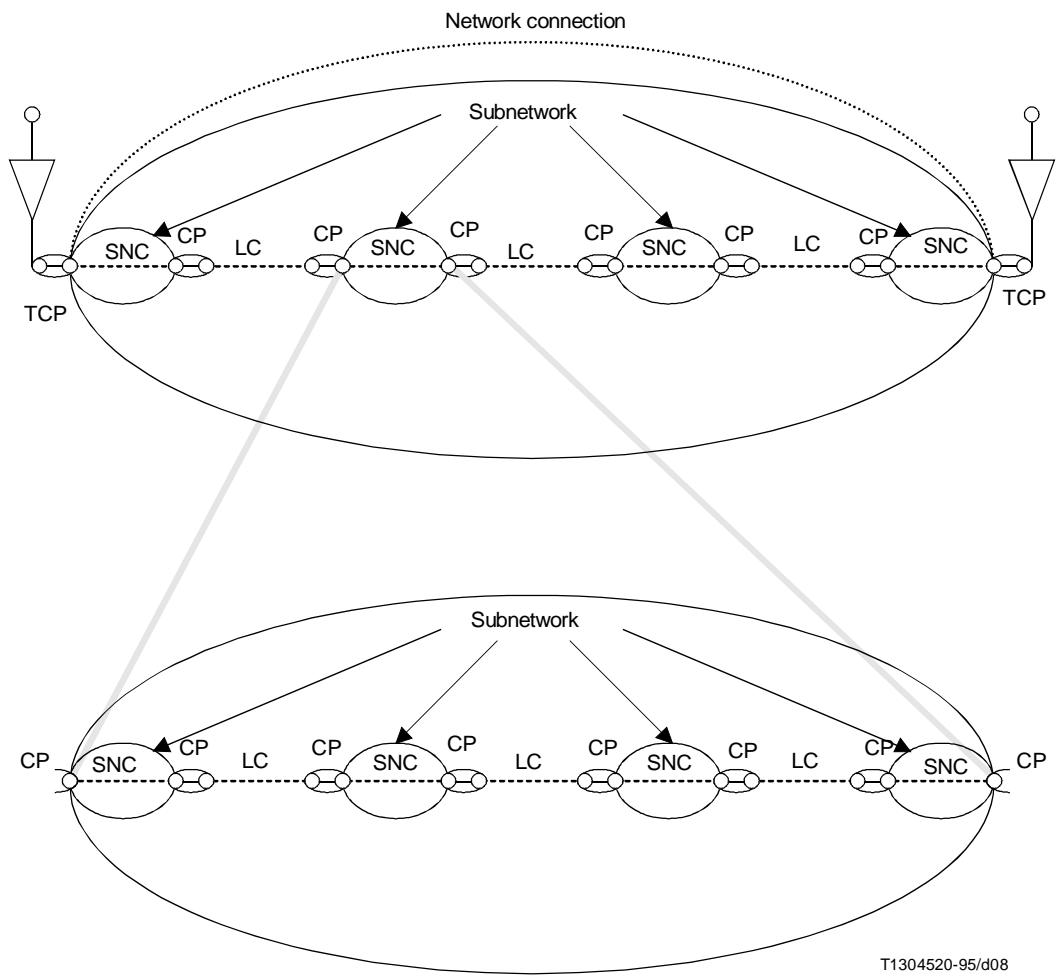

FIGURE 6/G.805  
**Partitioning of layer networks and subnetworks**



T1304520-95/d08

- CP Connection Point
- LC Link Connection
- SNC Subnetwork Connection
- TCP Termination Connection Point

FIGURE 7/G.805  
**Decomposition of a network connection**

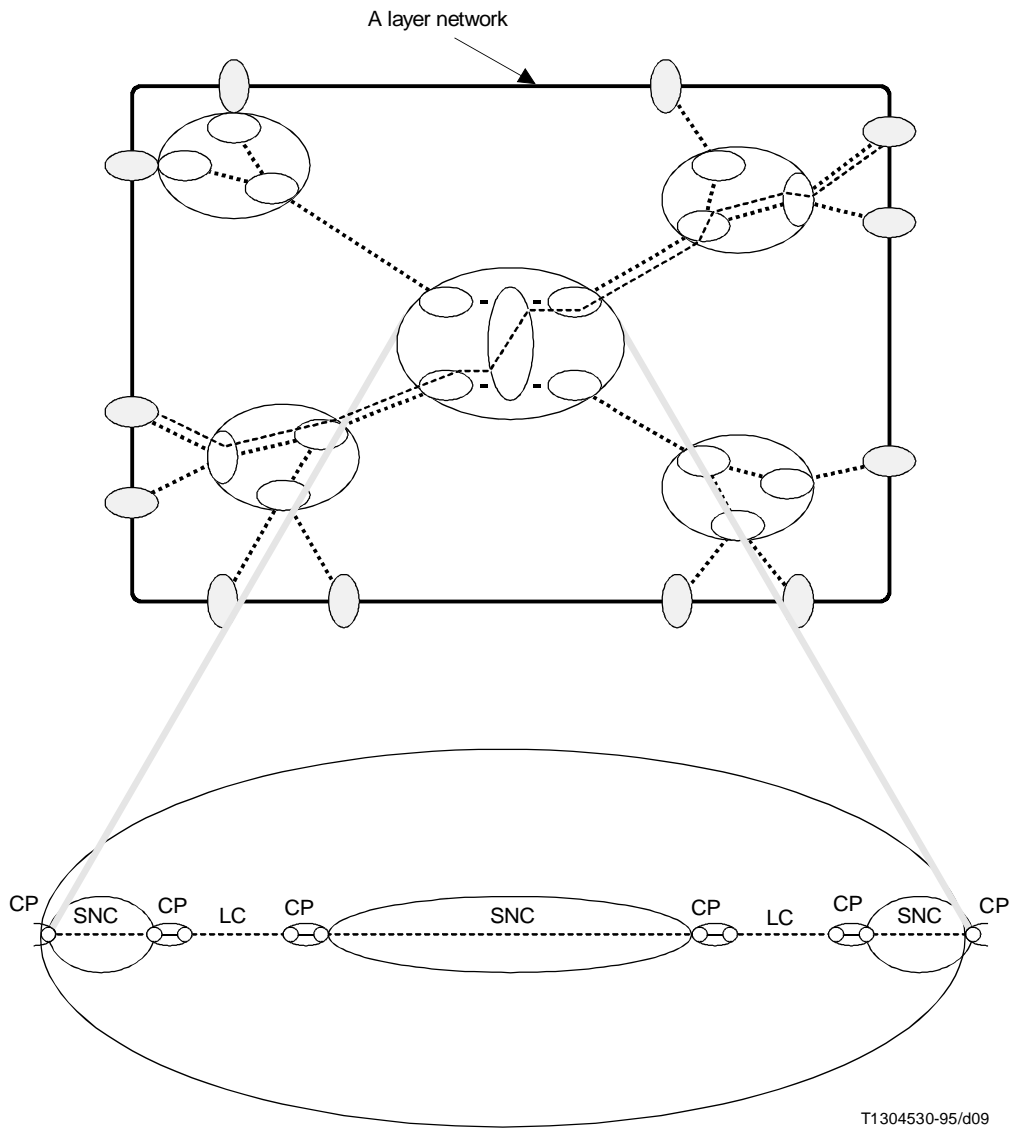

----- Trail  
 CP Connection Point  
 LC Link Connection  
 SNC Subnetwork Connection

FIGURE 8/G.805  
**Relationship between partitioning of subnetworks  
 and decomposition of connections**

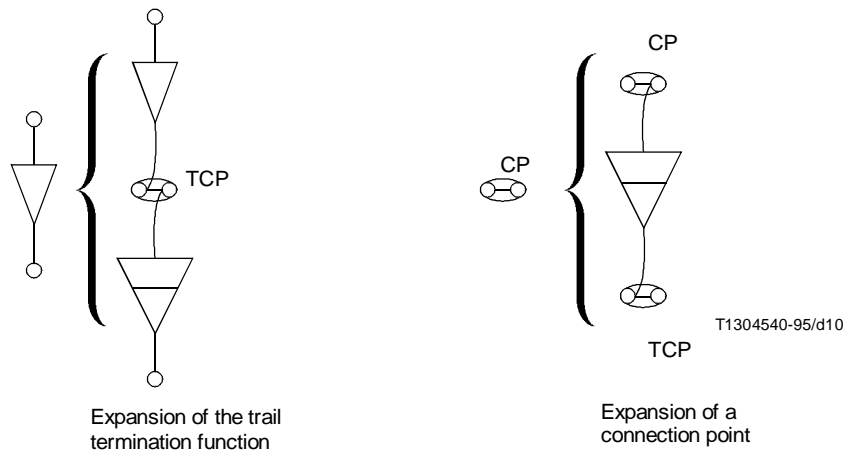

CP Connection Point  
 TCP Termination Connection Point

FIGURE 9/G.805  
**Generation of sublayers**

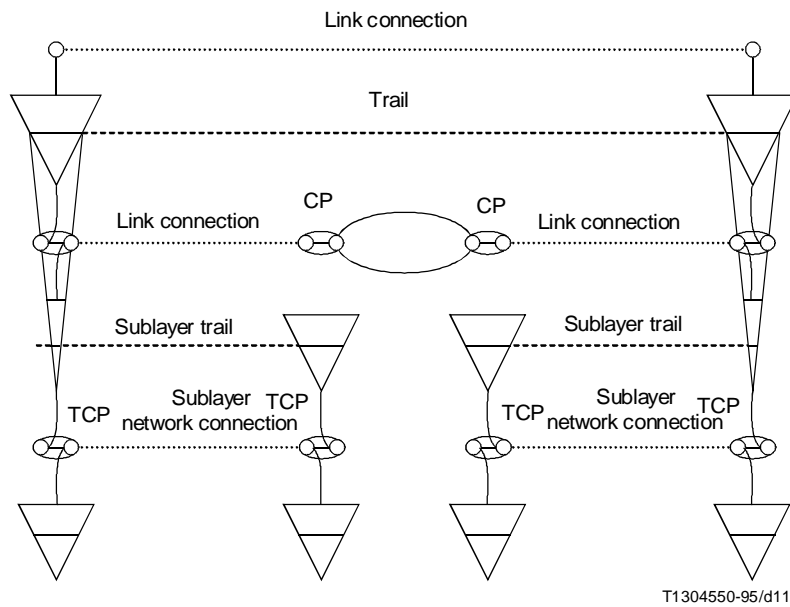

CP Connection Point  
 TCP Termination Connection Point

FIGURE 10/G.805  
**The concept of sublayering**

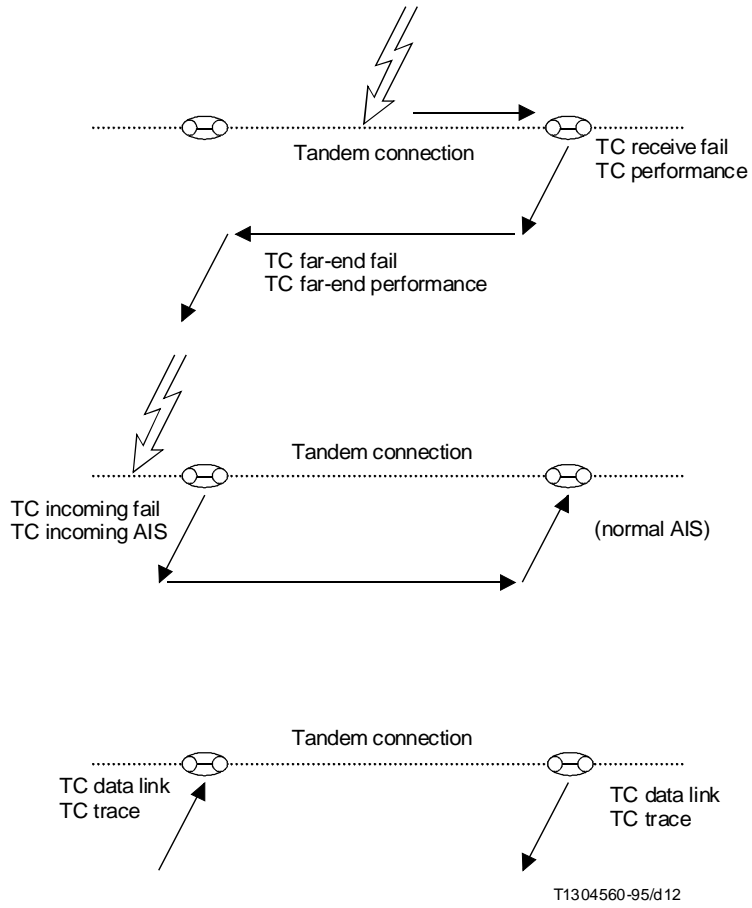

TC Tandem Connection

FIGURE 11/G.805  
Explanation of tandem connection terms

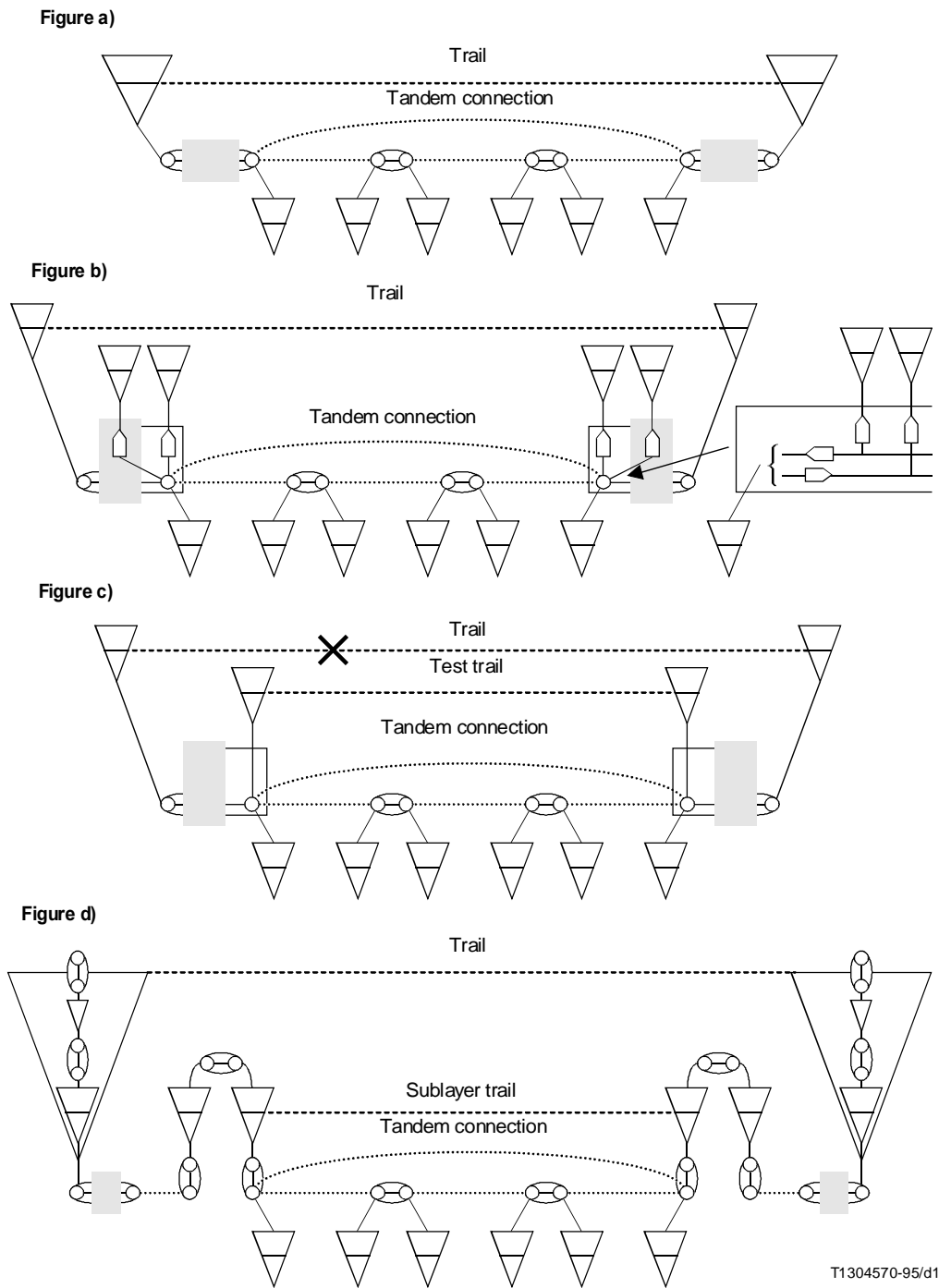

T1304570-95/d13

**FIGURE 12/G.805**  
**Connection monitoring**

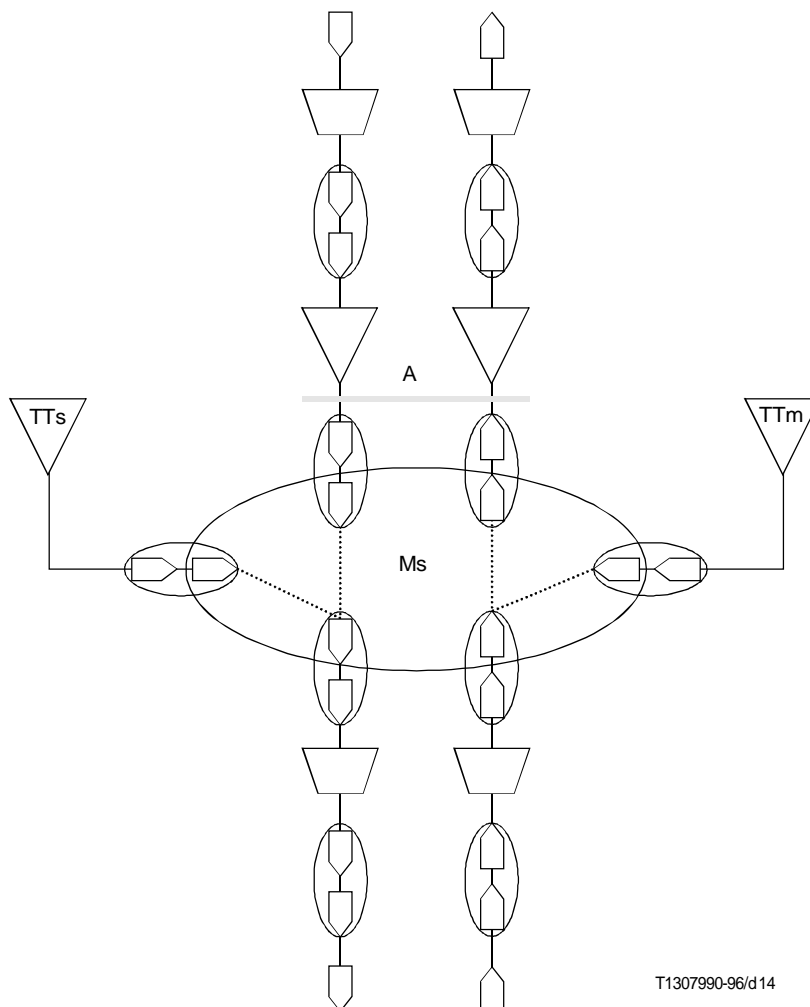

T1307990-96/d14

Ms Supervision matrix  
 TTs Supervisory Trail Termination  
 TTm Monitor trail termination

NOTE – Since the supervision matrix only supports the supervision function, a separate matrix is required for connection management at A.

FIGURE 13/G.805  
**Monitoring of unused connections**



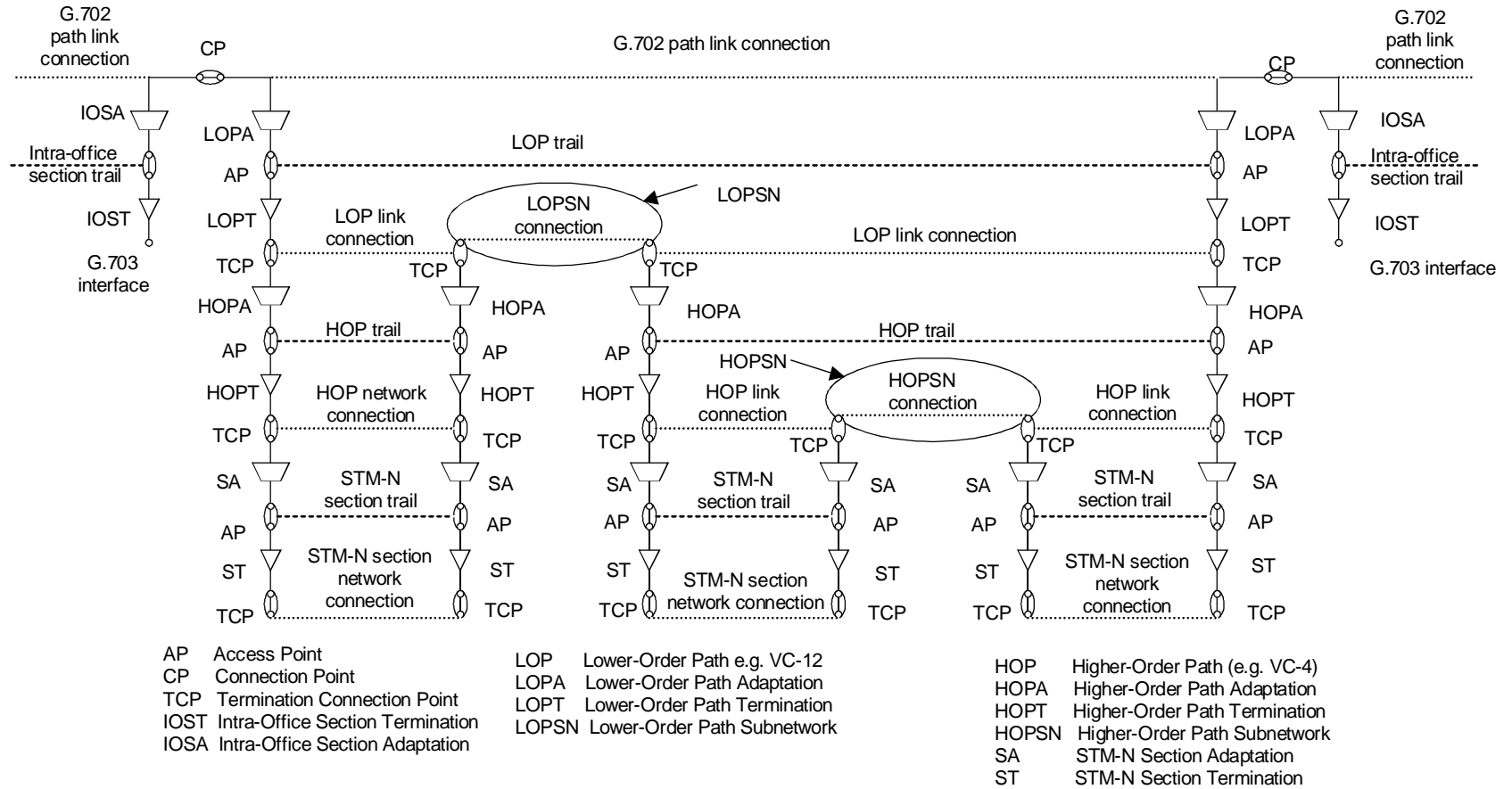
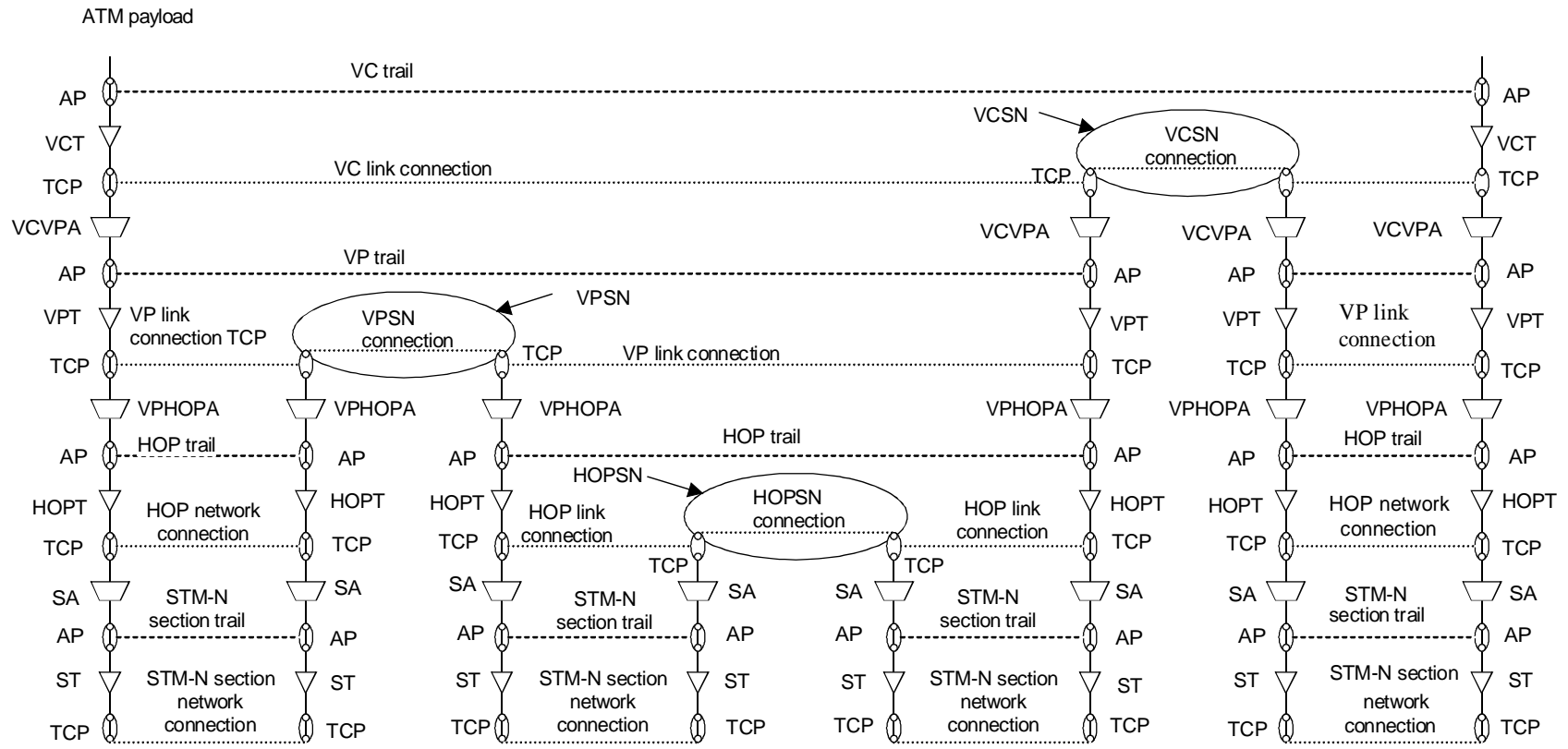

FIGURE 14/G.805

Application of the functional architecture to the case of PDH supported on SDH

T1304590-95/d15



T1304600-95/d16

AP	Access Point	VP	Virtual Path	HOP	Higher-Order Path (e.g. VC-4)
CP	Connection Point	VCVPA	VC to VP Adaptation	HOPT	Higher-Order Path Termination
TCP	Termination Connection Point	VPT	Virtual Path Termination	HOPSN	Higher-Order Path Subnetwork
VC	Virtual Channel	VPSN	Virtual Path Subnetwork	SA	STM-N Section Adaptation
VCA	Virtual Channel Adaptation	VPHOPA	VP to Higher-Order Path Adaptation	ST	STM-N Section Termination
VCT	Virtual Channel Termination				
VCSN	Virtual Channel Subnetwork				

FIGURE 15/G.805

Application of the functional architecture to the case of ATM supported on SDH

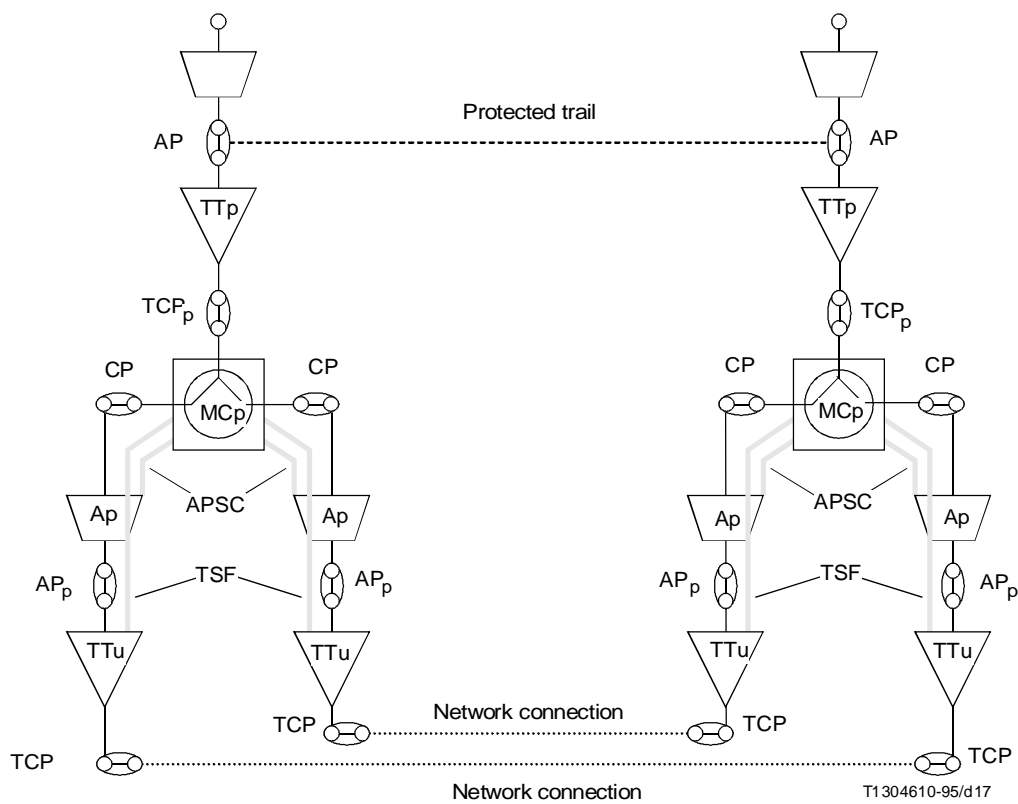

- TSF Trail Signal Fail
- APSC Automatic Protection Switch Channel
- TTP Protected Trail Termination
- TTu Unprotected Trail Termination
- Ap Protection Adaptation
- MCP Protection Matrix Connection
- TCP<sub>p</sub> Protection TCP
- AP<sub>p</sub> Protection Access Point

FIGURE 16/G.805  
Trail protection

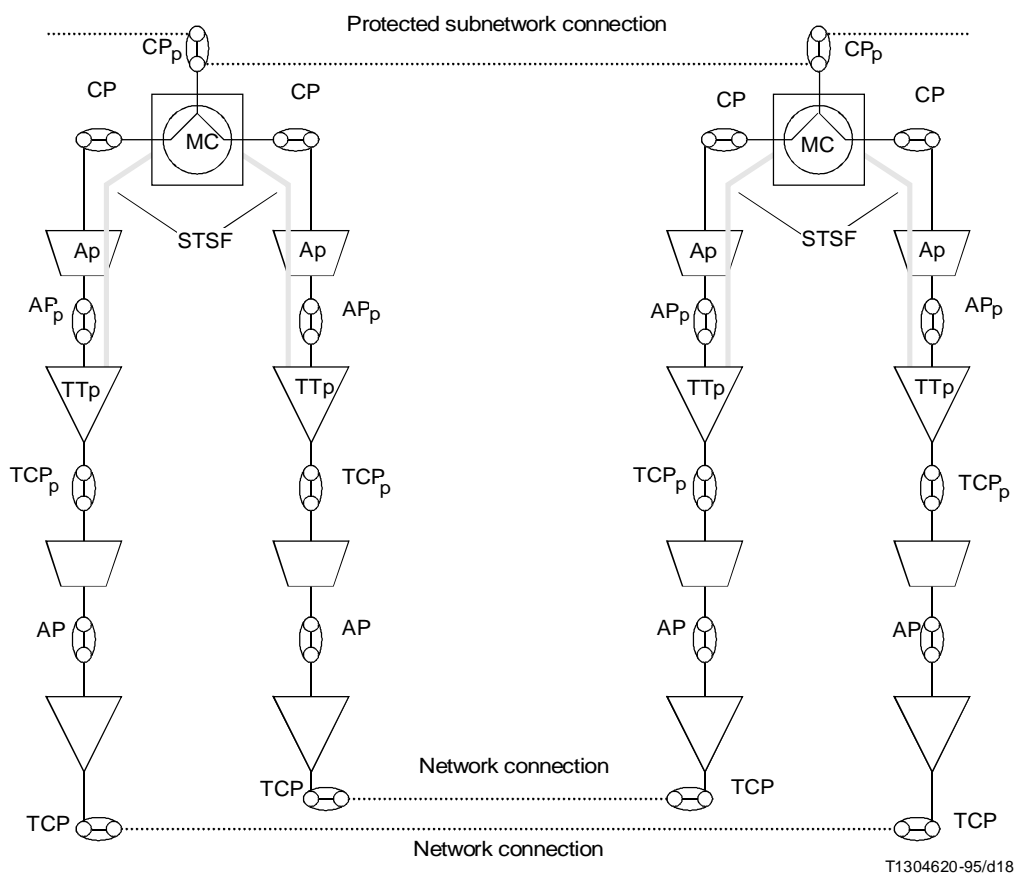

- STSF    Sublayer Trail Signal Fail
- TTp    Protection trail termination
- Ap    Protection adaptation
- MC    Matrix connection
- TCPp    Protection TCP
- APp    Protection access point
- CPp    Protection connection point

FIGURE 17/G.805  
Subnetwork connection protection using sublayering

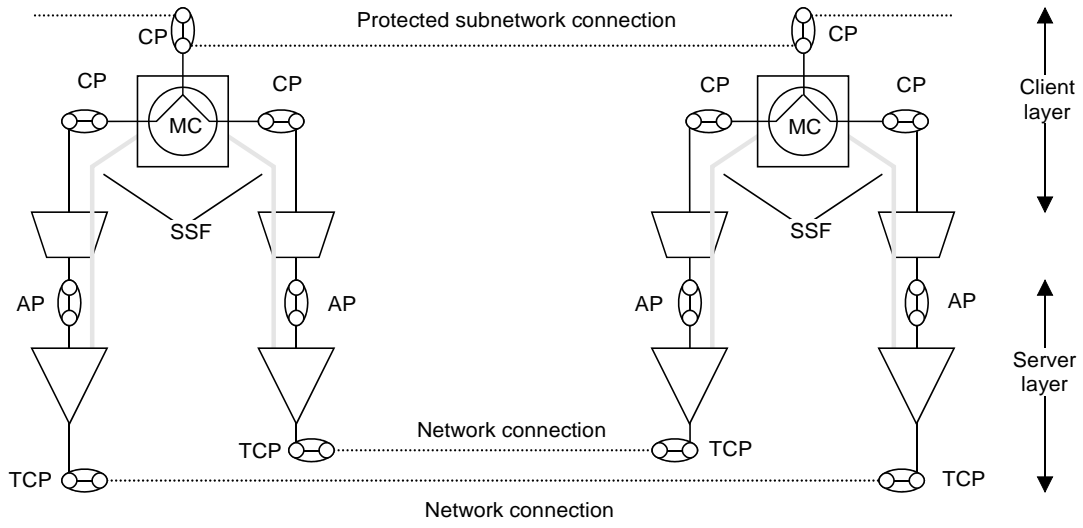

T1304630-95/d19

- AP Access Point
- CP Connection Point
- TCP Termination Connection Point
- SSF Server Signal Fail
- MC Matrix Connection

FIGURE 18/G.805  
**Subnetwork connection protection using inherent monitoring**

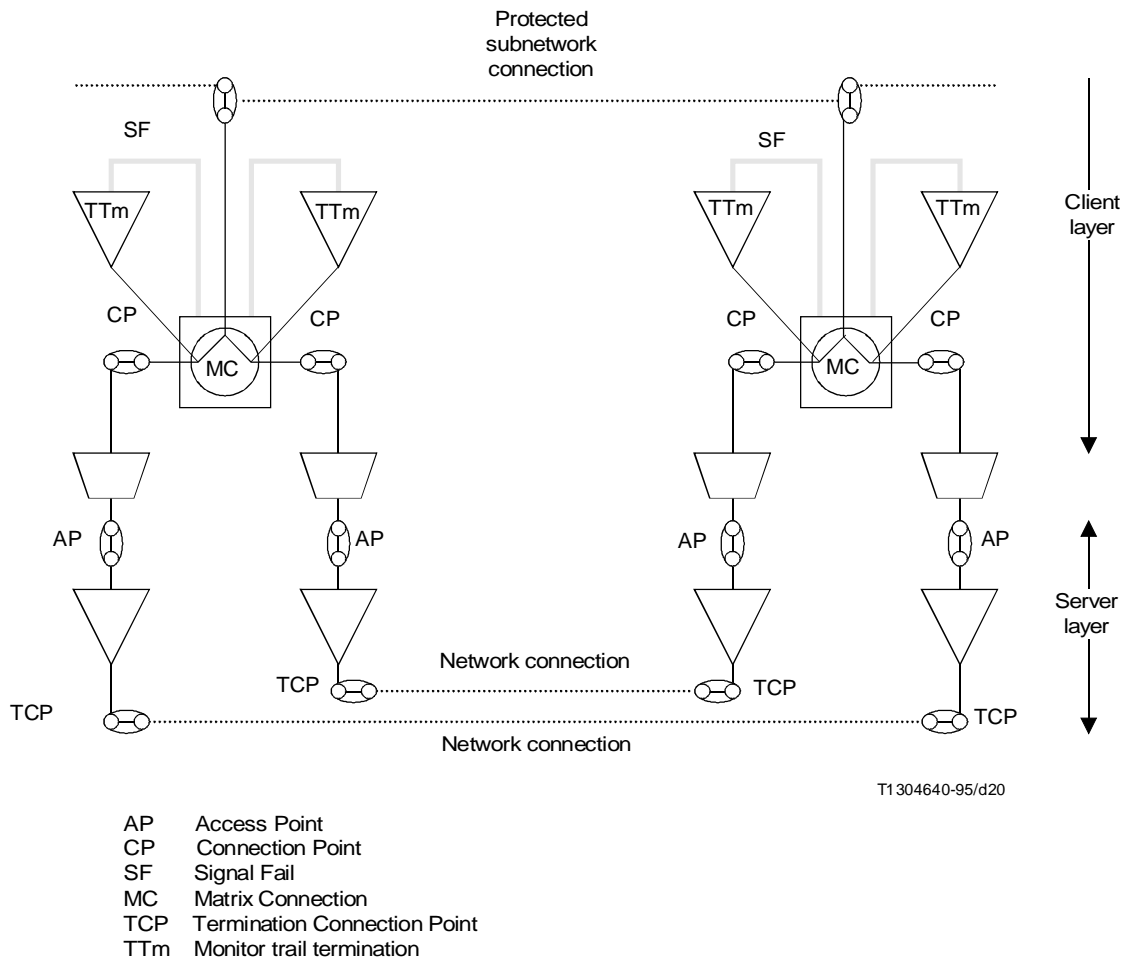

FIGURE 19/G.805  
Subnetwork connection protection using non-intrusive monitoring

## Appendix I

### Formal description of the architecture

(This appendix does not form an integral part of this Recommendation)

This appendix provides a formal definition of the architectural components defined in this Recommendation using the Z notation. A brief overview of Z is provided in Annex I.A of this appendix. Reference material for the Z notation may be found in the bibliography.

The fuZZ tool (also from Spivey) enables syntax and type checking of a Z specification.

#### I.1 General definitions

Format, Location and Point are considered to be atomic types.

Direction is defined here by enumeration of its permitted values, as well as BindingDone.

Architectural Component is a general type which is only defined by the characteristic information of the architectural component. It will be redefined later.

Transport networks are defined by:

- layerNetworks: the finite set of layer networks that compose it;
- chInfo: the association between all its layer networks and their proper characteristic information;
- internal: the association between its layer networks and their set of architectural components;
- clientsServers: the association (n to m relationship) between its layer networks.

Both transport entities (TransportEntity), topological components (TopologicalComponent), transport processing functions (TransportProcessingFunction) and reference points (ReferencePoint) are special kinds of architectural components (ArchitecturalComponent). As such, they have all the characteristics of architectural components (declaration part) and they verify all the predicates of architectural components (predicate part). In addition, a transport entity has a direction; a transport processing function has a location name (locationName); a reference point has a location name, a direction, and its two composing points may be bound or not. The predicate part of ReferencePoint indicates that, inside a reference point, a point is either bound to another one or not, but cannot be bound to more than one point.

[Format, Location, Point]

Direction ::= source | sink | bid

BindingDone ::= yes | no

CharacteristicInformation

format: Format

ArchitecturalComponent

characInfo: CharacteristicInformation

TransportNetwork

layerNetworks: F LayerNetwork  
 chInfo: LayerNetwork >--->> CharacteristicInformation  
 internal: LayerNetwork >-++-> F<sub>1</sub> ArchitecturalComponent  
 clientsServers: LayerNetwork <----> LayerNetwork

TransportEntity

ArchitecturalComponent  
 direction: Direction

TopologicalComponent

ArchitecturalComponent

TransportProcessingFunction

ArchitecturalComponent  
 locationName: Location

ReferencePoint

ArchitecturalComponent  
 locationName: Location  
 binding: Point >-++-> Point  
 boundReferencePoint: BindingDone  
 direction: Direction

#binding ≤ 1  
 #binding = 0 ⇔ boundReferencePoint = no  
 #binding = 1 ⇔ boundReferencePoint = yes

Some useful classifications:

sourceReferencePoint \_\_, sinkReferencePoint \_\_, bidirReferencePoint \_\_ : ReferencePoint

$\forall p: \text{ReferencePoint} \bullet$ sourceReferencePoint p $\Leftrightarrow$ p.direction = source $\wedge$ sinkReferencePoint p $\Leftrightarrow$ p.direction = sink $\wedge$ bidirReferencePoint p $\Leftrightarrow$ p.direction = bid
---------------------------------------------------------------------------------------------------------------------------------------------------------------------------------------------------------------------------------------------------------------

## I.2 Reference points

Access points (AccessPoint) and connection points (ConnectionPoint) are special kinds of reference points (ReferencePoint).

An access group (AccessGroup) is a set named setOfTtfs of trail termination functions (TrailTerminationFunction) which are all co-located, i.e. for any pair of trail termination functions of this set, their location name attribute value is similar.

AccessPoint

ReferencePoint
----------------

ConnectionPoint

ReferencePoint
----------------

## Others

AccessGroup

setOfTtfs: P TrailTermination <sup>2)</sup> $\forall \{tff1, tff2\} \subseteq \text{setOfTtfs} \bullet$ tff1.locationName = tff2.locationName
-----------------------------------------------------------------------------------------------------------------------------------------------------

## I.3 Topological components

A link may be terminated either by a subnetwork or an access group.

The definition of Acyclic is generic in order to be applied to any relation. For any relation R, Acyclic R is true if, x being related to y, y is never related to x through transitive closure of the relation.

AnyNetwork is a general definition of networks for both layer networks and subnetworks. It is defined by:

- the finite set of inner subnetworks (subnetworks);
- the non-empty finite set of inner links (links);
- its topology, i.e. the whole set of associations between link ends (topology);
- its partitioning (partitioning);
- the finite set of connections in the network (connections).

Moreover, the predicate part indicates that:

- the partitioning is acyclic, i.e. a subnetwork cannot be inside itself;
- subnetworks contain the whole set of inner subnetworks, including all levels of partitioning.

<sup>2)</sup> P power set.



A layer network (LayerNetwork) is a special case of network (AnyNetwork). Additionally, it is defined by a non-empty finite set of access group (accessGroup) that delimit the layer network and the finite set of trails (trails) that cross it.

LayerNetworkInit states that, in its initial state, i.e. just after commissioning, the set of trails that cross a layer network as well as the set of connections are empty.

A subnetwork (Subnetwork) is a special kind of network which is also defined by the finite set of connection points (setOfCPs) that delimit it.

SubnetworkInit indicates that, in its initial state, any given subnetwork is delimited by connection points in which the binding between points is not realized.

A matrix (Matrix) is a special kind of subnetwork (SubNetwork) in which where delimiting connection points are all co-located.

A LinkEnd is either a SubNetwork or an AccessGroup.

```
LinkEnd ::=      subNetworkLE << SubNetwork >>
                | accessGroupLE << AccessGroup >>

[X]
```

Acyclic _: P (X <----> X)
$\forall R: X \text{ <----> } X \bullet$ Acyclic R $\Leftrightarrow R^+ \cap \text{id } X = \emptyset$

#### AnyNetwork

subNetworks: F SubNetwork links: F <sub>1</sub> Link topology: LinkEnd <----> LinkEnd __ partitions __: SubNetwork --++-> SubNetwork connections: F Connection
Acyclic partitions $\forall \text{sn: SubNetwork} / \text{sn} \in \text{subNetworks} \bullet$ sn.subNetworks $\subseteq$ subNetworks

#### LayerNetwork

AnyNetwork accessGroups: F <sub>1</sub> AccessGroup trails: F Trail
---------------------------------------------------------------------------

#### LayerNetworkInit

LayerNetwork
trails = $\emptyset$ connections = $\emptyset$

#### SubNetwork

AnyNetwork setOfCPs: F ConnectionPoint
-------------------------------------------

#### SubNetworkInit

SubNetwork
$\forall \text{snp} \in \text{setOfCPs} \bullet$ snp.boundReferencePoint = no

Matrix

SubNetwork

$\forall \{snp1, snp2\} \subseteq \text{setOfCPs} \bullet$   
 $snp1.locationName = snp2.locationName$

Link

TopologicalComponent

#### I.4 Transport entities

A connection (Connection) is a special kind of transport entity. Moreover, we define uni and bidirectional connections by stating explicitly that their direction attribute value is equal to `bidir` or not.

A link connection (LinkConnection) is a relationship between two connection points.

A network connection (NetworkConnection) is a relationship between two connection points. This relationship can be obtained by a non-null number of iterations of (0 or more point-to-point subnetwork connections followed by 0 or more link connections).

A trail (Trail) is a relationship between two access points. Moreover, the predicate part indicates that, if two given access points `ap1` and `ap2` are related by a trail, `ap1` is related to a trail termination then to a network connection then to the reverse of a trail termination and finally to `ap2`.

Connection

TransportEntity

UniDirectionalConnection

Connection

`direction`  $\neq$  `bidir`

BiDirectionalConnection

Connection

`direction` = `bidir`

`__LinkConnection__`: `ConnectionPoint`  $\text{>-+++>}$  `ConnectionPoint`

`__NetworkConnection__`: `ConnectionPoint`  $\text{>-+++>}$  `ConnectionPoint`

$\forall (cp1, cp2) \in ( \text{__NetworkConnection__} ) \bullet$   
 $cp1 ( \text{PointToPointSubNetworkConnection}^*; \text{LinkConnection}^* )^+ cp2$

`__PointToPointMatrixConnection__`:

`ConnectionPoint`  $\text{>-+++>}$  `ConnectionPoint`

`__Trail__`: `AccessPoint`  $\text{>-+++>}$  `AccessPoint`

`ap1 Trail ap2`

$\Leftrightarrow$

`ap1 Ttf; NetworkConnection; Ttf~ ap2`

`__MonitoredPointToPointTandemConnection__`:

`ConnectionPoint`  $\text{>-+++>}$  `ConnectionPoint`

$\forall (cp1, cp2) \in ( \text{__MonitoredPointToPointTandemConnection__} ) \bullet$   
 $cp1 ( \text{PointToPointSubNetworkConnection}^*; \text{LinkConnection}^* )^+ cp2$

## I.5 Transport processing functions

\_\_ Tff \_\_ : AccessPoint >----> ConnectionPoint

\_\_ Adaptation \_\_ : F1 ConnectionPoint >----> AccessPoint

### Bibliography

SPIVEY (J.M.): The Z notation – A reference manual (2nd ed.), *Prentice Hall International Series in computer science*. ISBN 0-13-978529-9.

## Annex I.A

(to Appendix I of Recommendation G.805)

### A short introduction to Z

**I.A.1** Z is a formal notation based on set theory and first order predicate logic. The basic modelling concept in Z is the set. As in mathematics, a set may be defined either by extension (by enumerating its elements) or by comprehension (by providing a predicate that all potential elements should verify). In this latter case, it is equivalent to defining a type. A convenient means to define a type by comprehension in Z is through the definition of a schema. A schema can be named or not. A named schema may be used to define a type or an operation. It has the following form:

Schema-name

Declaration
Predicate

where:

- Declaration is composed of a list of characteristics of the schema; and
- Predicate is a (possibly empty) list of predicates specifying either invariants or pre-conditions or post-conditions.

The reader of a Z specification should keep in mind that, though notational conventions render specifications quite complex, the basic modelling concepts are simple. For the sake of readability, the following specification will not make use of all the tricks that exist in Z to make a specification shorter but, on the contrary, will only use simple Z constructs in order to remain understandable by non-experts.

### I.A.2 Example #1

The definition of the set of points, namely Point, defined both by their x and y coordinates, by means of a named schema could be:

Point

x : Integer y : Integer
----------------------------

Moreover, it states that both x and y are characteristics of a point and are of type Integer (which is assumed to be pre-defined).

An example of the specification of an operation by means of a schema is:

MoveToCenter

$\Delta$ Point
x' = 0 y' = 0

This schema MoveToCenter defines an operation that modifies the point on which the operation is applied (the symbol  $\Delta$  indicates that the state of Point is changed by the operation) and states that the values of  $x$  and  $y$  after the completion of the operation (respectively  $x'$  and  $y'$ ) are both 0.

### I.A.3 Example #2

A schema can also contain global definitions, e.g. relationships between other sets. For example, square is a function which both source and target sets are  $\mathbb{N}$  (set of natural numbers). The  $_$  character placed after the function name indicates that the postfix notation is required. Moreover, the predicate part specifies that, for all natural number  $n$ ,  $\text{square}(n)$  is obtained by multiplying  $n$  by itself:

---

Square  $_$  :  $\mathbb{N} \rightarrow \mathbb{N}$

$\forall n: \mathbb{N} \bullet$

$$\text{square}(n) = n * n$$

Moreover, the following symbols are used in this specification (it should be noted that all kinds of binary relationships can be modelled):

- 1)  $\langle \text{----} \rangle$ : a binary relation. If  $X$  and  $Y$  are sets, then  $X \langle \text{----} \rangle Y$  is the set of binary relations between  $X$  and  $Y$ . Each such relation is a subset of  $X \times Y$  (cartesian product).
- 2)  $\text{--}+\text{--} \rangle$ : a partial function. If  $X$  and  $Y$  are sets,  $X \text{--}+\text{--} \rangle Y$  is the set of partial functions from  $X$  to  $Y$ . These are relations which relate each member  $x$  of  $X$  to at most one member of  $Y$ .
- 3)  $\text{----} \rangle$ : a total function (or application). If  $X$  and  $Y$  are sets,  $X \text{----} \rangle Y$  is the set of total functions from  $X$  to  $Y$ . These are partial functions with domain  $X$ ; they relate each member  $x$  of  $X$  to exactly one member of  $Y$ .
- 4)  $\text{>}+\text{--} \rangle$ : a partial injection. If  $X$  and  $Y$  are sets,  $X \text{>}+\text{--} \rangle Y$  is the set of partial injections from  $X$  to  $Y$ . These are partial functions. The inverse of a partial injection relates to each member of  $Y$  at most one member of  $X$ .
- 5)  $\text{>} \text{----} \rangle$ : a total injection, i.e. a partial injection which is also a total function.
- 6)  $\text{--}+\text{--} \rangle \rangle$ : a partial surjection. If  $X$  and  $Y$  are sets,  $X \text{--}+\text{--} \rangle \rangle Y$  is the set of partial surjections from  $X$  to  $Y$ . These are partial functions from  $X$  to  $Y$  which have the whole of  $Y$  as their range.
- 7)  $\text{----} \rangle \rangle$ : a total surjection, i.e. a function which has the whole of  $X$  as its domain and the whole of  $Y$  as its range.
- 8)  $\text{>} \text{----} \rangle \rangle$ : a bijection, i.e. both a surjection and an injection. It maps the elements of  $X$  onto the elements of  $Y$  in a one-to-one correspondence.
- 9)  $\_$ : inequality.
- 10)  $\in$ : membership.
- 11)  $\_$ : empty set.
- 12)  $\cup$ : set union.
- 13)  $\cap$ : set intersection.
- 14)  $\setminus$ : set difference.
- 15) *dom*, *ran*: domain and range of a relation. If  $R$  is a binary relation between  $X$  and  $Y$ , the domain of  $R$  (*dom*  $R$ ) is the set of all members of  $X$  which are related to at least one member of  $Y$  by  $R$ . The range of  $R$  (*ran*  $R$ ) is the set of all members of  $Y$  to which at least one member of  $X$  is related by  $R$ .
- 16)  $\text{::}$ : relational composition. The composition  $R; S$  of two relations  $R: X \langle \text{----} \rangle Y$  and  $S: Y \langle \text{----} \rangle Z$  relates a member  $x$  of  $X$  to a member  $z$  of  $Z$  if and only if there is at least one member  $y$  of  $Y$  to which  $x$  is related by  $R$  and which itself related to  $z$  by  $S$ .
- 17)  $\sim$ : relational inversion. An object  $y$  is related  $\sim$  to an object  $x$  by the relational inversion  $R \sim$  if and only if  $x$  is related to  $y$  by  $R$ .

- 18) \*: reflexive-transitive closure. If  $R$  is a relation from a set  $X$  to itself,  $R^*$  is the strongest relation containing  $R$  which is both reflexive and transitive.
- 19) #: number of members of a set.
- 20) partition: a family  $S$  partitions a set  $T$  if and only if:
- each pair of sets  $S(i)$  and  $S(j)$  for  $i \neq j$  have empty intersection; and
  - the union of all the sets  $S(i)$  is  $T$ .
- 21)  $\vee$ : disjunction.
- 22)  $\wedge$ : conjunction.
- 23)  $\Leftrightarrow$ : equivalence.
- 24)  $\forall$ : universal quantifier.
- 25)  $\exists$ : existential quantifier.
- 26)  $\exists!$ : unique quantifier.
- 27)  $\mathcal{P}$ : power set. If  $S$  is a set,  $\mathcal{P}S$  is the set of all the subsets of  $S$ .
- 28)  $\times$ : cartesian product. If  $S_1, \dots, S_n$  are sets, then  $S_1 \times \dots \times S_n$  is the set of all  $n$ -tuples  $(x_1, \dots, x_n)$  where  $x_i \in S_i$  for each  $i$  with  $1 \leq i \leq n$ .