



INTERNATIONAL TELECOMMUNICATION UNION

ITU-T

TELECOMMUNICATION
STANDARDIZATION SECTOR
OF ITU

G.783

(04/97)

SERIES G: TRANSMISSION SYSTEMS AND MEDIA,
DIGITAL SYSTEMS AND NETWORKS

Digital transmission systems – Terminal equipments –
Principal characteristics of multiplexing equipment for the
synchronous digital hierarchy

**Characteristics of synchronous digital hierarchy
(SDH) equipment functional blocks**

ITU-T Recommendation G.783

(Previously CCITT Recommendation)

ITU-T G-SERIES RECOMMENDATIONS

TRANSMISSION SYSTEMS AND MEDIA, DIGITAL SYSTEMS AND NETWORKS

INTERNATIONAL TELEPHONE CONNECTIONS AND CIRCUITS	G.100–G.199
<i>INTERNATIONAL ANALOGUE CARRIER SYSTEM</i>	
GENERAL CHARACTERISTICS COMMON TO ALL ANALOGUE CARRIER-TRANSMISSION SYSTEMS	G.200–G.299
INDIVIDUAL CHARACTERISTICS OF INTERNATIONAL CARRIER TELEPHONE SYSTEMS ON METALLIC LINES	G.300–G.399
GENERAL CHARACTERISTICS OF INTERNATIONAL CARRIER TELEPHONE SYSTEMS ON RADIO-RELAY OR SATELLITE LINKS AND INTERCONNECTION WITH METALLIC LINES	G.400–G.449
COORDINATION OF RADIOTELEPHONY AND LINE TELEPHONY	G.450–G.499
<i>TRANSMISSION MEDIA CHARACTERISTICS</i>	
<i>DIGITAL TRANSMISSION SYSTEMS</i>	
TERMINAL EQUIPMENTS	G.700–G.799
General	G.700–G.709
Coding of analogue signals by pulse code modulation	G.710–G.719
Coding of analogue signals by methods other than PCM	G.720–G.729
Principal characteristics of primary multiplex equipment	G.730–G.739
Principal characteristics of second order multiplex equipment	G.740–G.749
Principal characteristics of higher order multiplex equipment	G.750–G.759
Principal characteristics of transcoder and digital multiplication equipment	G.760–G.769
Operations, administration and maintenance features of transmission equipment	G.770–G.779
Principal characteristics of multiplexing equipment for the synchronous digital hierarchy	G.780–G.789
Other terminal equipment	G.790–G.799
DIGITAL NETWORKS	G.800–G.899
General aspects	G.800–G.809
Design objectives for digital networks	G.810–G.819
Quality and availability targets	G.820–G.829
Network capabilities and functions	G.830–G.839
SDH network characteristics	G.840–G.849
Telecommunications management network	G.850–G.859
DIGITAL SECTIONS AND DIGITAL LINE SYSTEM	G.900–G.999
General	G.900–G.909
Parameters for optical fibre cable systems	G.910–G.919
Digital sections at hierarchical bit rates based on a bit rate of 2048 kbit/s	G.920–G.929
Digital line transmission systems on cable at non-hierarchical bit rates	G.930–G.939
Digital line systems provided by FDM transmission bearers	G.940–G.949
Digital line systems	G.950–G.959
Digital section and digital transmission systems for customer access to ISDN	G.960–G.969
Optical fibre submarine cable systems	G.970–G.979
Optical line systems for local and access networks	G.980–G.999

For further details, please refer to ITU-T List of Recommendations.

ITU-T RECOMMENDATION G.783

CHARACTERISTICS OF SYNCHRONOUS DIGITAL HIERARCHY (SDH) EQUIPMENT FUNCTIONAL BLOCKS

Summary

This Recommendation is a merged, revised version of Recommendations G.781, G.782 and G.783 approved under the WTSC Resolution No. 1 procedure in January, 1994.

This Recommendation defines the interfaces and functions to be supported by SDH equipment. The description is generic and no particular physical partitioning of functions is implied. The input/output information flows associated with the functional blocks serve for defining the functions of the blocks and are considered to be conceptual, not physical.

Not every atomic function defined in this Recommendation is required for every application. Different subsets of atomic functions may be assembled in different ways according to the combination rules given in this Recommendation to provide a variety of different capabilities. Network operators and equipment suppliers may choose which functions must be implemented for each application.

Background

Recommendation	
Issue	Notes
1997	Second revision adds new protection and Tandem Connection monitoring applications. The modelling techniques used are converted to use atomic functions to be consistent with Recommendation G.803.
1994	First revision added specifications to cover cross-connect as well as multiplex equipment.
1990	Initial version.

Source

ITU-T Recommendation G.783 was revised by ITU-T Study Group 15 (1997-2000) and was approved under the WTSC Resolution No. 1 procedure on the 8th of April 1997.

FOREWORD

ITU (International Telecommunication Union) is the United Nations Specialized Agency in the field of telecommunications. The ITU Telecommunication Standardization Sector (ITU-T) is a permanent organ of the ITU. The ITU-T is responsible for studying technical, operating and tariff questions and issuing Recommendations on them with a view to standardizing telecommunications on a worldwide basis.

The World Telecommunication Standardization Conference (WTSC), which meets every four years, establishes the topics for study by the ITU-T Study Groups which, in their turn, produce Recommendations on these topics.

The approval of Recommendations by the Members of the ITU-T is covered by the procedure laid down in WTSC Resolution No. 1.

In some areas of information technology which fall within ITU-T's purview, the necessary standards are prepared on a collaborative basis with ISO and IEC.

NOTE

In this Recommendation, the expression "Administration" is used for conciseness to indicate both a telecommunication administration and a recognized operating agency.

INTELLECTUAL PROPERTY RIGHTS

The ITU draws attention to the possibility that the practice or implementation of this Recommendation may involve the use of a claimed Intellectual Property Right. The ITU takes no position concerning the evidence, validity or applicability of claimed Intellectual Property Rights, whether asserted by ITU members or others outside of the Recommendation development process.

As of the date of approval of this Recommendation, the ITU had not received notice of intellectual property, protected by patents, which may be required to implement this Recommendation. However, implementors are cautioned that this may not represent the latest information and are therefore strongly urged to consult the TSB patent database.

© ITU 1998

All rights reserved. No part of this publication may be reproduced or utilized in any form or by any means, electronic or mechanical, including photocopying and microfilm, without permission in writing from the ITU.

CONTENTS

		<i>Page</i>
1	General	1
	1.1 References	3
	1.2 Abbreviations	3
	1.3 Definitions	11
	1.4 Reference point naming	16
	1.5 Reference point information naming	17
	1.6 Atomic function naming and diagrammatic conventions.....	19
	1.7 Atomic function process allocation	22
	1.8 Combination rules.....	25
	1.9 Fault management and performance monitoring naming.....	28
	1.10 Fault management and performance monitoring specification techniques.....	29
	1.11 Performance and reliability.....	29
2	Supervision processes and management information flows	30
	2.1 Information flow (XXX_MI) across the XXX_MP reference points	30
	2.2 Supervision	32
	2.3 Generic processes	49
3	SDH physical layer.....	54
	3.1 Connection.....	55
	3.2 Termination: OS _n _TT and ES _n _TT	56
	3.3 Adaptation	60
	3.4 Sublayer functions (N/A).....	64
4	Regenerator section layer	64
	4.1 Connection (Not/Applicable).....	65
	4.2 Termination: RS _n _TT	65
	4.3 Adaptation	68
	4.4 Sublayer functions (N/A).....	76
5	Multiplex section layer.....	76
	5.1 Connection (N/A)	77
	5.2 Termination: MS _n _TT.....	77
	5.3 Adaptation	81
	5.4 Sublayer functions	90
6	Higher order SDH path (S _n) layer.....	94
	6.1 Connection Functions: S _n _C	99
	6.2 Termination functions: S _n _TT, S _{nm} _TT and S _{ns} _TT	103
	6.3 Adaptation functions.....	111
	6.4 Sublayer functions	117
7	Lower order SDH path (S _m) layer	138
	7.1 Connection functions: S _m _C	147
	7.2 Termination functions: S _m _TT, S _{mm} _TT and S _{ms} _TT	152
	7.3 Adaptation functions.....	160
	7.4 Sublayer functions	163
8	Compound functions	177
	8.1 Transport Terminal Function (TTF)	177
	8.2 Higher Order Interface (HOI).....	178
	8.3 Lower Order Interface (LOI)	178
	8.4 Higher Order Assembler (HOA).....	179

	<i>Page</i>
9	Timing functions 179
9.1	Synchronous Equipment Timing Source (SETS) function 179
9.2	Synchronous Equipment Timing Physical Interface (SETPI) function..... 181
10	Specification of jitter and wander 182
10.1	STM-N interfaces 182
10.2	PDH interfaces..... 184
11	Overhead Access Function (OHA)..... 190
Annex A – Multiplex Section Protection (MSP) protocol, commands and operation 191	
A.1	MSP Protocol 191
A.2	MSP commands 195
A.3	Switch operation 196
Annex B – Multiplex section protection (MSP) 1 + 1 optimized protocol, commands and operation 200	
B.1	1 + 1 bidirectional switching optimized for a network using predominantly 1 + 1 bidirectional switching..... 200
B.2	Switch commands..... 202
B.3	Switch operation 202
Annex C – Algorithm for pointer detection..... 204	
C.1	Pointer interpretation 204
C.2	Concatenated payloads 205
C.3	Pointer processing flow chart 206
Annex D – PDH physical section layers..... 208	
D.1	PDH physical section layer (<i>E_q</i>)..... 208
Appendix I – Example of F1 byte usage..... 213	
Appendix II – CM configuration examples 214	
Appendix III – Example of remote indication operation 218	
III.1	Remote Defect Indication (RDI)..... 218
III.2	Remote Error Indication (REI) 218
Appendix IV – Alarm Indication Signal (AIS)..... 222	
Appendix V – Signal Fail (SF) and Signal Degrade (SD) 224	
V.1	Server Signal Fail (SSF) signal..... 224
V.2	Server Signal Degrade (aSSD) signal 224
V.3	Trail Signal Fail (TSF) signal 224
V.4	Trail Signal Degrade (TSD) signal 224
Appendix VI – Data Communications Channel (DCC)..... 224	
Appendix VII – Atomic function modelling of basic functions from 1994 G.783 225	

CHARACTERISTICS OF SYNCHRONOUS DIGITAL HIERARCHY (SDH) EQUIPMENT FUNCTIONAL BLOCKS

(revised in 1997)

1 General

Since they have first been approved within CCITT Study Group (SG) XV, Recommendations G.781, G.782 and G.783 have formed together a coherent set of Recommendations containing the basic specifications for the development of synchronous digital hierarchy network equipments. While revising these three Recommendations, CCITT SG XV first, and then ITU-T SG 15, have brought quite a number of changes (new features have been added, original ones have been differently specified, new modelling method has been developed) to the Recommendations. It has therefore been felt necessary to restructure the Recommendations, and the solution that consisted of merging them in a single Recommendation has been favoured. This has led to developing a new G.783 Recommendation with the aim of alignment with the functional modelling method defined in Recommendations G.803 and G.805.

This Recommendation specifies a library of basic building blocks and a set of rules by which they may be combined in order to describe a digital transmission equipment. The library is comprised of the functional building blocks needed to specify completely the generic functional structure of the synchronous digital hierarchy. These building blocks are illustrated in Figure 1-1. In order to be compliant with this Recommendation, equipment needs to be describable as an interconnection of a subset of these functional blocks contained within this Recommendation. The interconnections of these blocks should obey the combination rules given.

This Recommendation specifies both the components and the methodology that should be used in order to specify SDH processing; it does not specify an individual SDH equipment as such.

The specification method is based on functional decomposition of the equipment into atomic, and compound functions. The equipment is then described by its Equipment Functional Specification (EFS) which lists the constituent atomic and compound functions, their interconnection, and any overall performance objectives (e.g. transfer delay, availability, etc.).

The internal structure of the implementation of this functionality (equipment design) need not be identical to the structure of the functional model, as long as all the details of the externally observable behaviour comply with the EFS.

The equipment functionality is consistent with the SDH multiplexing structure given in Recommendation G.707.

Equipment developed prior to the production of the revision of this Recommendation may not comply in all details with this Recommendation.

Equipment which is normally stated to be compliant with this Recommendation may not fulfil all the requirements in the case that it is interworking with old equipment that is not compliant with this Recommendation.

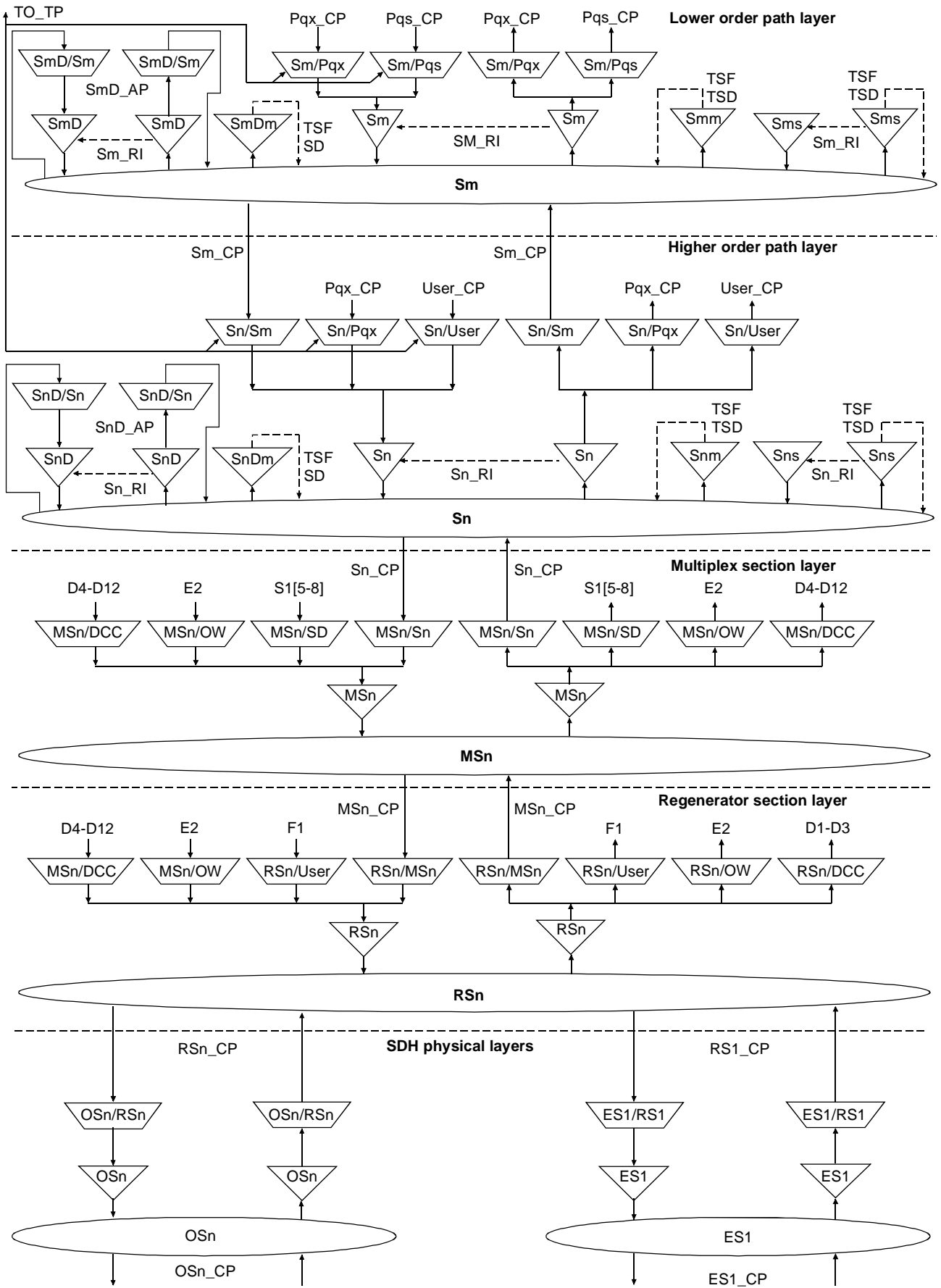

Figure 1-1/G.783 – General functional block diagram

T1525250-97/d001

1.1 References

The following ITU-T Recommendations and other references contain provisions which, through reference in this text, constitute provisions of this Recommendation. At the time of publication, the editions indicated were valid. All Recommendations and other references are subject to revision; all users of this Recommendation are therefore encouraged to investigate the possibility of applying the most recent edition of the Recommendations and other references listed below. A list of the currently valid ITU-T Recommendations is regularly published.

- CCITT Recommendation G.703 (1991), *Physical electrical characteristics of hierarchical digital interfaces.*
- ITU-T Recommendation G.704 (1995), *Synchronous frame structures used at 1544, 6312, 2048, 8488 and 44 736 kbit/s hierarchical levels.*
- CCITT Recommendation G.706 (1991), *Frame alignment and Cyclic Redundancy Check (CRC) procedures relating to basic frame structures defined in Recommendation G.704.*
- ITU-T Recommendation G.707 (1996), *Network node interface for the Synchronous Digital Hierarchy (SDH).*
- CCITT Recommendation G.743 (1988), *Second order digital multiplex equipment operating at 6312 kbit/s and using positive justification.*
- CCITT Recommendation G.752 (1980), *Characteristics of digital multiplex equipments based on a second order bit rate of 6312 kbit/s and using positive justification.*
- ITU-T Recommendation G.775 (1994), *Loss of Signal (LOS) and Alarm Indication Signal (AIS) defect detection and clearance criteria.*
- ITU-T Recommendation G.784 (1994), *Synchronous Digital Hierarchy (SDH) management.*
- ITU-T Recommendation G.803 (1997), *Architecture of transport networks based on the Synchronous Digital Hierarchy (SDH).*
- ITU-T Recommendation G.805 (1995), *Generic functional architecture of transport networks.*
- ITU-T Recommendation G.810 (1996), *Definitions and terminology for synchronization networks.*
- CCITT Recommendation G.812 (1988), *Timing requirements at the outputs of slave clocks suitable for plesiochronous operation of international digital links.*
- ITU-T Recommendation G.813 (1996), *Timing characteristics of SDH equipment slave clocks (SEC).*
- ITU-T Recommendation G.823 (1993), *The control of jitter and wander within digital networks which are based on the 2048 kbit/s hierarchy.*
- ITU-T Recommendation G.824 (1993), *The control of jitter and wander within digital networks which are based on the 1544 kbit/s hierarchy.*
- ITU-T Recommendation G.825 (1993), *The control of jitter and wander within digital networks which are based on the Synchronous Digital Hierarchy (SDH).*
- ITU-T Recommendation G.826 (1996), *Error performance parameters and objectives for international, constant bit rate digital paths at or above the primary rate.*
- ITU-T Recommendation G.831 (1996), *Management capabilities of transport networks based on the Synchronous Digital Hierarchy (SDH).*
- ITU-T Recommendation G.841 (1995), *Types and characteristics of SDH network protection architectures.*
- ITU-T Recommendation G.957 (1995), *Optical interfaces for equipment and systems relating to synchronous digital hierarchy.*
- ITU-T Recommendation G.958 (1994), *Digital line systems based on the synchronous digital hierarchy for use on optical fibre cables.*
- ITU-T Recommendation M.3010 (1996), *Principles for a telecommunications management network.*

1.2 Abbreviations

This Recommendation uses the following abbreviations:

A	Adaptation function
AcSL	Accepted Signal Label

AcTI	Accepted Trace Identifier
ADM	Add-Drop Multiplexer
AI	Adapted Information
AIS	Alarm Indication Signal
ALS	Automatic Laser Shutdown
AP	Access Point
APId	Access Point Identifier
APS	Automatic Protection Switching
ATM	Asynchronous Transfer Mode
AU	Administrative Unit
AU- <i>n</i>	Administrative Unit, level <i>n</i>
AUG	Administrative Unit Group
BER	Bit Error Ratio
BBER	Background Block Error Ratio
BIP	Bit Interleaved Parity
C	Connection function
CI	Characteristic Information
CK	Clock
CM	Connection Matrix
CMISE	Common Management Information Service Element
CP	Connection Point
CRC	Cyclic Redundancy Check
CRC-N	Cyclic Redundancy Check, width <i>N</i>
CSES	Consecutive Severely Errored Seconds
D	Data
DCC	Data Communications Channel
DEC	Decrement
DEG	Degraded
DEGTHR	Degraded Threshold
DS	Defect Second
DXC	Digital Cross Connect
E0	Electrical interface signal 64 kbit/s
E11	Electrical interface signal 1544 kbit/s
E12	Electrical interface signal 2048 kbit/s
E22	Electrical interface signal 8448 kbit/s
E31	Electrical interface signal 34 368 kbit/s
E32	Electrical interface signal 44 736 kbit/s
E4	Electrical interface signal 139 264 kbit/s
EBC	Errored Block Count

EDC	Error Detection Code
EDCV	Error Detection Code Violation
EMF	Equipment Management Function
EQ	Equipment
ES	Electrical Section
ES1	Electrical Section, level 1
ES	Errored Second
E_q	Recommendation G.703 type electrical signal, bit rate order q ($q = 11, 12, 21, 22, 31, 32, 4$)
ExSL	Expected Signal Label
ExTI	Expected Trace Identifier
F_B	Far-end Block
F_DS	Far-end Defect Second
F_EBC	Far-end Errored Block Count
FAS	Frame Alignment Signal
FIFO	First In First Out
FM	Fault Management
FOP	Failure of Protocol
FS	Forced Switch
FS	Frame Start signal
HO	Higher Order
HOA	Higher Order Assembler
HOI	Higher Order Interface
HOVC	Higher Order Virtual Container
HP	Higher order Path
HPA	Higher order Path Adaptation
HPC	Higher order Path Connection
HPOM	Higher order Path Overhead Monitor
HPP	Higher order Path Protection
HPT	Higher order Path Termination
HSUT	Higher order path Supervisory Unequipped Termination
HTCA	Higher order path Tandem Connection Adaptation
HTCM	Higher order path Tandem Connection Monitor
HTCT	Higher order path Tandem Connection Termination
ID	Identifier
IF	In Frame state
INC	Increment

LC	Link Connection
LO	Lockout
LO	Lower Order
LOA	Loss of Alignment; generic for LOF, LOM, LOP
LOF	Loss of Frame
LOI	Lower Order Interface
LOM	Loss of Multiframe
LOP	Loss of Pointer
LOS	Loss of Signal
LOVC	Lower Order Virtual Container
LP	Lower order Path
LPA	Lower order Path Adaptation
LPC	Lower order Path Connection
LPOM	Lower order Path Overhead Monitor
LPP	Lower order Path Protection
LPT	Lower order Path Termination
LSUT	Lower order path Supervisory Unequipped Termination
LTCA	Lower order path Tandem Connection Adaptation
LTCM	Lower order path Tandem Connection Monitor
LTCT	Lower order path Tandem Connection Termination
LTI	Loss of all Incoming Timing references
MC	Matrix Connection
MCF	Message Communications Function
MI	Management Information
MON	Monitored
MP	Management Point
MRTIE	Maximum Relative Time Interval Error
MS	Manual Switch
MS	Multiplex Section
MSA	Multiplex Section Adaptation
MSB	Most Significant Bit
MS _n	Multiplex Section layer, level n (n = 1, 4, 16)
MSOH	Multiplex Section OverHead
MSP	Multiplex Section Protection
MST	Multiplex Section Termination
MTIE	Maximum Time Interval Error
N_B	Near-end Block

N_BBE	Near-end Background Block Error
N_DS	Near-end Defect Second
N_EBC	Near-end Errored Block Count
NC	Network Connection
N.C.	Not Connected
NDF	New Data Flag
NE	Network Element
NEF	Network Element Function
NMON	Not Monitored
NNI	Network Node Interface
NU	National Use
OAM	Operation, Administration and Maintenance
ODI	Outgoing Defect Indication
OEI	Outgoing Error Indication
OFS	Out-of-Frame Second
OHA	OverHead Access
OOF	Out of Frame
OS	Optical Section
OS _n	Optical Section layer, level n (n = 1, 4, 16)
OW	Order Wire
P0x	64 kbit/s layer (transparent)
P11x	1544 kbit/s layer (transparent)
P12s	2048 kbit/s PDH path layer with synchronous 125 μs frame structure according to Recommendation G.704
P12x	2048 kbit/s layer (transparent)
P21x	6312 kbit/s layer (transparent)
P22e	8448 kbit/s PDH path layer with 4 plesiochronous 2048 kbit/s
P22x	8448 kbit/s layer (transparent)
P31e	34 368 kbit/s PDH path layer with 4 plesiochronous 8448 kbit/s
P31s	34 368 kbit/s PDH path layer with synchronous 125 μs frame structure according to Recommendation G.832
P31x	34 368 kbit/s layer (transparent)
P32x	44 736 kbit/s layer (transparent)
P4a	139 264 kbit/s PDH path layer with 3 plesiochronous 44 736 kbit/s
P4e	139 264 kbit/s PDH path layer with 4 plesiochronous 34 368 kbit/s

P4s	139 264 kbit/s PDH path layer with synchronous 125 μ s frame structure according to Recommendation G.832
P4x	139 264 kbit/s layer (transparent)
PDH	Plesiochronous Digital Hierarchy
PJC	Pointer Justification Count
PJE	Pointer Justification Event
PLM	PayLoad Mismatch
PM	Performance Monitoring
POH	Path OverHead
PPI	PDH Physical Interface
Pq	PDH path layer, bit rate order q (q = 11, 12, 21, 22, 31, 32, 4)
PRC	Primary Reference Clock
PS	Protection Switching
PSC	Protection Switch Count
PSD	Protection Switch Duration
PSE	Protection Switch Event
PSS	Protection Switch Second
PTR	Pointer
RDI	Remote Defect Indication
REI	Remote Error Indication
RI	Remote Information
RP	Remote Point
RS	Regenerator Section
RSn	Regenerator Section layer, level n (n = 1, 4, 16)
RSOH	Regenerator Section OverHead
RST	Regenerator Section Termination
RxSL	Received Signal Label
RxTI	Received Trace Identifier
S11	VC-11 path layer
S11D	VC-11 tandem connection sublayer
S11P	VC-11 path protection sublayer
S12	VC-12 path layer
S12D	VC-12 tandem connection sublayer
S12P	VC-12 path protection sublayer
S2	VC-2 path layer
S2D	VC-2 tandem connection sublayer
S2P	VC-2 path protection sublayer
S3	VC-3 path layer

S3D	VC-3 tandem connection sublayer using TCM definition according to Annex D/G.707 (option 2)
S3P	VC-3 path protection sublayer
S3T	VC-3 tandem connection sublayer using TCM definition according to Annex C/G.707 (option 1)
S4	VC-4 path layer
S4D	VC-4 tandem connection sublayer using TCM definition according to Annex D/G.707 (option 2)
S4P	VC-4 path protection sublayer
S4T	VC-4 tandem connection sublayer using TCM definition according to Annex C/G.707 (option 1)
SD	Signal Degrade
SDH	Synchronous Digital Hierarchy
SDXC	Synchronous Digital hierarchy Cross-Connect
SEC	SDH Equipment Clock
SEMF	Synchronous Equipment Management Function
SES	Severely Errored Second
SETG	Synchronous Equipment Timing Generator
SETPI	Synchronous Equipment Timing Physical Interface
SETS	Synchronous Equipment Timing Source
SF	Signal Fail
Sk	Sink
Sm	lower order VC- <i>m</i> layer ($m = 11, 12, 2, 3$)
SmD	VC- <i>m</i> ($m = 11, 12, 2, 3$) tandem connection sublayer
Smm	VC- <i>m</i> ($m = 11, 12, 2, 3$) path layer non-intrusive monitor
SmP	VC- <i>m</i> ($m = 11, 12, 2, 3$) path protection sublayer
Sms	VC- <i>m</i> ($m = 11, 12, 2, 3$) path layer supervisory-unequipped
Sn	Higher order VC- <i>n</i> layer ($n = 3, 4$)
SnD	VC- <i>n</i> ($n = 3, 4$) tandem connection sublayer using TCM definition according to Annex D/G.707 (option 2)
Snm	VC- <i>n</i> ($n = 3, 4$) path layer non-intrusive monitor
SnP	VC- <i>n</i> ($n = 3, 4$) path protection sublayer
Sns	VC- <i>n</i> ($n = 3, 4$) path layer supervisory-unequipped

<i>SnT</i>	VC- <i>n</i> (<i>n</i> = 3, 4) tandem connection sublayer using TCM definition according to Annex C/G.707 (option 1)
SNC	SubNetwork Connection
SNC/I	Inherently monitored SubNetwork Connection protection
SNC/N	Non-intrusively monitored SubNetwork Connection protection
SNC/S	Sublayer (tandem connection) monitored SubNetwork Connection protection
So	Source
SOH	Section OverHead
SPI	SDH Physical Interface
SPRING	Shared Protection Ring
SSD	Server Signal Degrade
SSF	Server Signal Fail
SSM	Synchronization Status Message
SSU	Synchronization Supply Unit
STM	Synchronous Transport Module
TCM	Tandem Connection Monitor
TCP	Termination Connection Point
TD	Transmit Degrade
TF	Transmit Fail
TFAS	trail Trace identifier Frame Alignment Signal
TI	Timing Information
TIM	Trace Identifier Mismatch
TMN	Telecommunications Management Network
TP	Timing Point
TPmode	Termination Point mode
TS	Time Slot
TSD	Trail Signal Degrade
TSF	Trail Signal Fail
TSL	Trail Signal Label
TT	Trail Termination function
TTs	Trail Termination supervisory function
TTI	Trail Trace Identifier
TTP	Trail Termination Point
TU	Tributary Unit
TU- <i>m</i>	Tributary Unit, level <i>m</i>
TUG	Tributary Unit Group
TUG- <i>m</i>	Tributary Unit Group, level <i>m</i>

TxSL	Transmitted Signal Label
TxTI	Transmitted Trace Identifier
UNEQ	UnEquipped
UNI	User Network Interface
USR	User channels
VC	Virtual Container
VC- <i>n</i>	Virtual Container, level <i>n</i>
VP	Virtual Path
W	Working

1.3 Definitions

This Recommendation defines the following terms.

NOTE 1 – The following definitions are relevant in the context of SDH-related Recommendations.

NOTE 2 – References to G.703 signals are intended to refer only to PDH signals, and specifically not to an electrical STM-1 interface. The notation G.703 (PDH) has been used to convey this interpretation.

1.3.1 1 + 1 (protection) architecture: A 1+1 protection architecture has one normal traffic signal, one working SNC/trail, one protection SNC/trail and a permanent bridge.

At the source end, the normal traffic signal is permanently bridged to both the working and protection SNC/trail. At the sink end, the normal traffic signal is selected from the better of the two SNCs/trails.

Due to the permanent bridging, the 1+1 architecture does not allow an extra unprotected traffic signal to be provided.

1.3.2 1:n (protection) architecture ($n \geq 1$): A 1:n protection architecture has *n* normal traffic signals, *n* working SNCs/trails and one protection SNC/trail. It may have one extra traffic signal.

The signals on the working SNCs/trails are the normal traffic signals.

The signal on the protection SNC/trail may either be one of the normal traffic signals, an extra traffic signal, or the null signal (e.g. an all-ONEs signal, a test signal, one of the normal traffic signals). At the source end, one of these signals is connected to the protection SNC/trail. At the sink end, the signals from the working SNCs/trails are selected as the normal signals. When a defect condition is detected on a working SNC/trail or under the influence of certain external commands, the transported signal is bridged to the protection SNC/trail. At the sink end, the signal from this protection SNC/trail is then selected instead.

1.3.3 access point (AP): See Recommendation G.805.

1.3.4 access point identifier (APId): See Recommendation G.831.

1.3.5 active trail/path/section/SNC/NC: The trail/path/section/SNC from which the signal is selected by the protection selector.

1.3.6 adaptation function (A): See Recommendation G.805.

1.3.7 adapted information (AI): The information passing across an AP.

1.3.8 administrative unit (AU): See Recommendation G.707.

1.3.9 administrative unit group (AUG): See Recommendation G.707.

1.3.10 alarm: A human observable indication that draws attention to a failure (detected fault) usually giving an indication of the severity of the fault.

1.3.11 all-ONEs: The entire capacity of the adapted or characteristic information is set to logic "1".

1.3.12 anomaly: The smallest discrepancy which can be observed between the actual and desired characteristics of an item. The occurrence of a single anomaly does not constitute an interruption in the ability to perform a required function. Anomalies are used as the input for the Performance Monitoring (PM) process and for the detection of defects.

1.3.13 atomic function: A function which if divided into simpler functions would cease to be uniquely defined for digital transmission hierarchies. It is therefore indivisible from a network point of view. The following atomic functions are defined in each network layer:

- bidirectional Trail Termination function (..._TT), Trail Termination Source function (..._TT_So), Trail Termination Sink function (..._TT_Sk) and Connection function (..._Co);
- between client and server layer networks three adaptation functions are defined: Adaptation Sink function ..._A_Sk, Adaptation Source function ..._A_So, and the bidirectional Adaptation function ..._A.

1.3.14 AUn-AIS: See Recommendation G.707.

1.3.15 automatic laser shutdown (ALS): See Recommendation G.958.

1.3.16 automatic protection switching (APS): Autonomous switching of a signal between and including two MS_TT, Sn_TT, or Sm_TT functions, from a failed working trail/SNC to a protection trail/SNC and subsequent restoration using control signals carried by the K-bytes in the MSOH, HO POH, or LO POH.

1.3.17 basic function: A generic functionality consisting of combinations of atomic functions. The 1994 version of this Recommendation defined these functions.

1.3.18 bidirectional trail/connection type: A two-way trail/connection through a transport network.

1.3.19 bidirectional (protection) switching: For a unidirectional fault, both directions (of the trail, subnetwork connection, etc.), including the affected and unaffected direction, are switched.

1.3.20 bit interleaved parity (BIP): See Recommendation G.707.

1.3.21 broadcast connection type: An input CP is connected to more than one output CP.

1.3.22 characteristic information (CI): The information passing across a CP or TCP. See also Recommendation G.805.

1.3.23 client/server layer: Any two adjacent network layers are associated in a client/server relationship. Each transport network layer provides transport to the layer above and uses transport from the layers below. The layer providing transport is termed a server, the layer using transport is termed client.

1.3.24 connection: See Recommendation G.805.

1.3.25 connection function (C): An atomic function within a layer which, if connectivity exists, relays a collection of items of information between groups of atomic functions. It does not modify the members of this collection of items of information although it may terminate any switching protocol information and act upon it. Any connectivity restrictions between inputs and outputs shall be stated.

1.3.26 connection matrix (CM): A connection matrix is a matrix of appropriate dimensions which describe the connection pattern for assigning VC-ns on one side of an LPC or HPC function to VC-n capacities on the other side and vice versa.

1.3.27 connection point (CP): A reference point where the output of a trail termination source or a connection is bound to the input of another connection, or where the output of a connection is bound to the input of a trail termination sink or another connection. The connection point is characterized by the information which passes across it. A bidirectional connection point is formed by the association of a contra-directional pair.

NOTE – In the information model the connection point is called Connection Termination Point (CTP).

1.3.28 consolidation: The allocation of server layer trails to client layer connections which ensure that each server layer trail is full before the next is allocated. Consolidation minimizes the number of partially filled server layer trails. It therefore maximizes the fill factor.

Thus a number of partially filled VC-4 paths may be consolidated into a single, fully filled VC-4.

1.3.29 common management information service element (CMISE): See Recommendation X.710 and ISO/IEC 9595.

1.3.30 compound function: A function which represents a collection of atomic functions within one or more layer(s).

Example 1 – A combination of several atomic adaptation functions within a certain layer (each serving one client layer) is a compound adaptation function. A combination of a (compound) adaptation function and the layer's termination function is a compound function.

Example 2 – The atomic functions in the Optical Section (OS), Multiplex Section (MS) and Regenerator Section (RS) layers may be combined to form a major compound function.

The compound functions facilitate simplified descriptions of equipment. Standardized compound functions attach a unique name to a common combination of atomic functions.

1.3.31 data communications channel (DCC): See Recommendation G.784.

1.3.32 defect: The density of anomalies has reached a level where the ability to perform a required function has been interrupted. Defects are used as input for PM, the control of consequent actions, and the determination of fault cause.

1.3.33 desynchronizer: The desynchronizer function smoothes out the timing gaps resulting from decoded pointer adjustments and VC payload demapping in the time domain.

1.3.34 extra traffic signal: A signal that can be routed via the protection trail/path/section/SNC/NC if it is standby.

1.3.35 failure: The fault cause persisted long enough to consider the ability of an item to perform a required function to be terminated. The item may be considered as failed; a fault has now been detected.

1.3.36 fault: A fault is the inability of a function to perform a required action. This does not include an inability due to preventive maintenance, lack of external resources, or planned actions.

1.3.37 fault cause: A single disturbance or fault may lead to the detection of multiple defects. A fault cause is the result of a correlation process which is intended to identify the defect that is representative of the disturbance or fault that is causing the problem.

1.3.38 function: A process defined for digital transmission hierarchies (e.g. PDH, SDH) which acts on a collection of input information to produce a collection of output information. A function is distinguished by the way in which characteristics of the collection of output information differs from the collection of input information.

1.3.39 grooming: The allocation of server layer trails to client layer connections which groups together client layer connections whose characteristics are similar or related.

Thus it is possible to groom Virtual Container, level 12 (VC-12) paths by service type, by destination, or by protection category into particular VC-4 paths which can then be managed accordingly. It is also possible to groom VC-4 paths according to similar criteria into Synchronous Transport Module (STM-N) sections.

1.3.40 holdoff time: See Recommendation G.841.

1.3.41 layer: A concept used to allow the transport network functionality to be described hierarchically as successive levels; each layer being solely concerned with the generation and transfer of its characteristic information.

1.3.42 management information (MI): The signal passing across an access point.

1.3.43 management point (MP): A reference point where the output of an atomic function is bound to the input of the element management function, or where the output of the element management function is bound to the input of an atomic function.

NOTE – The MP is not the TMN Q3 interface.

- 1.3.44 multiplex section (MS):** A multiplex section is the trail between and including two multiplex section trail termination functions.
- 1.3.45 multiplex section alarm indication signal (MS-AIS):** See Recommendation G.707.
- 1.3.46 multiplex section remote defect indication (MS-RDI):** See Recommendation G.707.
- 1.3.47 multiplex section overhead (MSOH):** See Recommendation G.707.
- 1.3.48 network connection (NC):** See Recommendation G.805.
- 1.3.49 network element function (NEF):** See Recommendation G.784.
- 1.3.50 network node interface (NNI):** See Recommendation G.707.
- 1.3.51 non-revertive (protection) operation:** In non-revertive operation, the traffic signal (service) does not return to the working SNC/trail if the switch requests are terminated.
- 1.3.52 normal signal:** A signal that is transmitted via a protected trail/section/path/SNC/NC.
- 1.3.53 overhead access (OHA):** The OHA function provides access to transmission overhead functions.
- 1.3.54 path:** A trail in a path layer.
- 1.3.55 path overhead (POH):** See Recommendation G.707.
- 1.3.56 pointer justification event (PJE):** A PJE is an inversion of the I- or D-bits of the pointer, together with an increment or decrement of the pointer value to signify a frequency justification.
- 1.3.57 process:** A generic term for an action or a collection of actions.
- 1.3.58 protection trail/path/section/SNC/NC:** A specific trail/path/section/SNC/NC that is part of a protection group and is labelled protection.
- 1.3.59 reference point:** The delimiter of a function.
- 1.3.60 regenerator section (RS):** A regenerator section is the trail between and including two regenerator section terminations.
- 1.3.61 regenerator section overhead (RSOH):** See Recommendation G.707.
- 1.3.62 remote defect indication (RDI):** A signal which conveys the defect status of the characteristic information received by the trail termination sink function back to the network element which originated the characteristic information.
- 1.3.63 remote error indication (REI):** A signal which conveys either the exact or truncated number of error detection code violations of the characteristic information as detected by the trail termination sink function back to the network element which originated the characteristic information.
- 1.3.64 remote information (RI):** The information passing across an RP; e.g. RDI and REI.
- 1.3.65 remote point (RP):** A reference point where the output of a trail termination sink function of a bidirectional trail termination is bound to the input of its trail termination source function, for the purpose of conveying information to the remote end.
- 1.3.66 revertive (protection) operation:** In revertive operation, the traffic signal (service) always returns to (or remains on) the working SNC/trail if the switch requests are terminated; i.e. when the working SNC/trail has recovered from the defect or the external request is cleared.
- 1.3.67 section:** A trail in a section layer.
- 1.3.68 server signal degrade (SSD):** A signal degrade indication output at the CP of an adaptation function.
- 1.3.69 server signal fail (SSF):** A signal fail indication output at the CP of an adaptation function.

1.3.70 signal degrade (SD): A signal indicating the associated data has degraded in the sense that a degraded defect (dDEG) condition is active.

1.3.71 signal fail (SF): A signal indicating the associated data has failed in the sense that a near-end defect condition (not being the degraded defect) is active.

1.3.72 standby trail/path/section/SNC: The trail/path/section/SNC from which the signal is **not** selected by the protection selector.

1.3.73 subnetwork connection (SNC): See Recommendation G.805.

1.3.74 supervisory-unequipped VC: See Recommendation G.707.

1.3.75 synchronous transport module (STM): See Recommendation G.707.

1.3.76 telecommunications management network (TMN): See Recommendation M.3010.

1.3.77 termination connection point (TCP): A special case of a connection point where a trail termination function is bound to an adaptation function or a connection function.

NOTE – In the information model the termination connection point is called Trail Termination Point (TTP).

1.3.78 timing information (TI): The information passing across a TP.

1.3.79 timing point (TP): A reference point where an output of the synchronization distribution layer is bound to the input of an adaptation source or connection function, or where the output of an adaptation sink function is bound to an input of the synchronization distribution layer.

1.3.80 trail: See Recommendation G.805.

1.3.81 trail signal degrade (TSD): A signal degrade indication output at the AP of a termination function.

1.3.82 trail signal fail (TSF): A signal fail indication output at the AP of a termination function.

1.3.83 trail termination function (TT): An atomic function within a layer which generates, adds, and monitors information concerning the integrity and supervision of adapted information.

1.3.84 trail trace identifier (TTI): See Recommendation G.707.

1.3.85 NE transit delay: NE transit delay is defined as the period of time taken for an information bit arriving at an NE input port to reappear at an output port on the same NE via a defect free trail.

Transit delay is affected by e.g.:

- time slot interchange;
- relationship of actual clock frequencies in all layers;
- synchronizers and desynchronizers;
- physical path (internal route) taken through the NE.

A transit delay measurement should define under which conditions the measurement was made to establish minimum and maximum values in seconds.

The specification of transit delays for NEs is outside the scope of this Recommendation.

1.3.86 tributary unit (TU-*m*): See Recommendation G.707.

1.3.87 TUm-AIS: See Recommendation G.707.

1.3.88 virtual container (VC-*n*): See Recommendation G.707.

1.3.89 working trail/path/section/SNC/NC: A specific trail/path/section/SNC/NC that is part of a protection group and is labelled working.

1.3.90 unequipped VC: See Recommendation G.707.

1.3.91 undefined bit: If a bit is undefined, its value is set to a logical "0" or a logical "1".

1.3.92 undefined byte: If a byte is undefined, it contains eight undefined bits.

NOTE – See regional standards for further specifications of the value of undefined bits.

1.3.93 unidirectional trail/connection type: A one-way trail/connection through a transport network.

1.3.94 unidirectional (protection) switching: For a unidirectional fault (i.e. a fault affecting only one direction of transmission), only the affected direction (of the trail, subnetwork connection, etc.) is switched.

1.3.95 wait to restore time: A period of time that must elapse before a – from a fault recovered – trail/connection can be used again to transport the normal traffic signal and/or to select the normal traffic signal from.

1.4 Reference point naming

The atomic functions of this Recommendation are defined between fixed reference points at which specified information is assumed to be present. That is, at a given reference point, specific types of information can always be assumed to be present. There are several different types of reference points within the functional model, including reference points for:

- transmission signals;
- management information;
- timing references;
- DCC channels;
- synchronization status messaging;
- user overhead bytes.

Some of these reference points are designated by a single capital letter, usually followed by a number designating which reference point of that type is being referred to. These are:

- timing references T
- DCC channels P or N
- synchronization status messaging Y
- user overhead bytes U

1.4.1 Transmission reference points

Because they are so numerous, and their detailed characteristics are so important to the functional model, transmission reference points are designated with a more complex naming convention. A transmission reference point name is formed by a transmission layer designation, followed by an underscore character, followed by either AP or CP, depending on whether that reference point is an Access Point (AP) or a Connection Point (CP). As described in Recommendation G.805, the information at an access point is a signal into which the client signal(s) have been mapped, but which does not include the full complement of overhead information for the given layer. The information at a connection point is a signal which includes the full complement of overhead information. The access point is at the server side of adaptation functions and the client side of termination functions. The connection point is at the client side of adaptation functions and the server side of termination functions (Figure 1-1). Thus, a transmission reference point name is formed according to the syntax:

<TransmissionReferencePointName> = <LayerName>_<AP or CP>

The layer names are:

- ES_n STM-n Electrical Section (n = 1).
- OS_n STM-n Optical Section (n = 1, 4, 16).
- RS_n STM-n Regenerator Section (n = 1, 4, 16).
- MS_n STM-n Multiplex Section (n = 1, 4, 16).
- S_n Higher order path (n = 3, 4).

<i>SnD</i>	Higher order path, tandem connection sublayer (n = 3, 4) using TCM definition according to Annex D/G.707 (option 2).
<i>SnT</i>	Higher order path, tandem connection sublayer (n = 3, 4) using TCM definition according to Annex C/G.707 (option 1).
<i>Sm</i>	Lower order path (m = 11, 12, 2, 3).
<i>SmD</i>	Lower order path, tandem connection sublayer (m = 11, 12, 2, 3).
<i>Pqs</i>	PDH synchronous user data (q = 11 for 1.5 Mbit/s, q = 12 for 2 Mbit/s).
<i>Pqx</i>	PDH user data (q = 11 for 1.5 Mbit/s, q = 12 for 2 Mbit/s, q = 2 for 6 Mbit/s, q = 31 for 34 Mbit/s, q = 32 for 45 Mbit/s, q = 4 for 140 Mbit/s).
<i>Eq</i>	PDH Electrical Section (q = 11 for 1.5 Mbit/s, q = 12 for 2 Mbit/s, q = 2 for 6 Mbit/s, q = 31 for 34 Mbit/s, q = 32 for 45 Mbit/s, q = 4 for 140 Mbit/s).

As an example of the application of this transmission reference point naming strategy, the following is the succession of reference points that a signal at a 2 Mbit/s electrical interface would progress through in the functional model of this Recommendation when being multiplexed into an optical STM-1:

E12_CP→E12_AP→P12x_CP→S12_AP→S12_CP→S4_AP→S4_CP→MS1_AP→
MS1_CP→RS1_AP→RS1_CP→OS1_AP→OS1_CP

Note also that it would be possible to define PDH path layers which would exist between the PDH electrical section and user data layers. However, their characteristics are not described in this Recommendation. The definition of the processing for the PDH layers is for further study, for inclusion in this or another Recommendation.

1.4.2 Management reference points

Management reference points are also quite numerous, and are therefore named directly after the name of the associated function according to the syntax (see Figure 1-1):

<ManagementReferencePointName> = <FunctionName>_MP

Thus, for example, the management reference point for the OS_TT function is named OS_TT_MP.

1.4.3 Timing reference points

Timing reference points are named directly after the name of the associated layer according to the syntax (see Figure 1-1):

<TimingReferencePointName> = <LayerName>_TP

Thus, for example, the timing reference point for the VC-4 layer is named S4_TP.

1.4.4 Remote reference points

Remote reference points are named directly after the name of the associated function layer to the syntax (see Figure 1-1):

<RemoteReferencePointName> = <LayerName>_RP

Thus, for example, the remote reference point for the VC-12 layer is named S12_RP.

1.5 Reference point information naming

The information passing a CP is called **Characteristic Information** (CI), the information passing an AP is called **Adapted Information** (AI), the information passing an MP is called **Management Information** (MI), and the information passing a TP is called **Timing Information** (TI).

1.5.1 Transmission reference point information naming

The coding of the Characteristic Information (CI) and Adapted Information (AI) in the model follows the following rules:

<layer>[/<client layer>] _<information type>[_<direction>] _<signal type>[/<number>].

[...] optional term;

<layer> represents one of the layer names (e.g. RS1);

<client layer> represents one of the client layer names (e.g. MS1 is a client of RS1);

<information type> CI or AI;

<direction> So (Source) or Sk (Sink);

<signal type> CK (clock); or
 D (data); or
 FS (Frame Start); or
 SSF (Server Signal Fail); or
 TSF (Trail Signal Fail); or
 SSD (Server Signal Degrade); or
 TSD (Trail Signal Degrade);

<number> indication of multiplex number; e.g. (1, 1, 1) for the case of a TU-12 within a VC-4.

AI and CI coding examples are: MS1_CI_D, RS16_AI_CK, S12/P12x_AI_D, S4/S2_AI_So_D/(2, 3, 0).

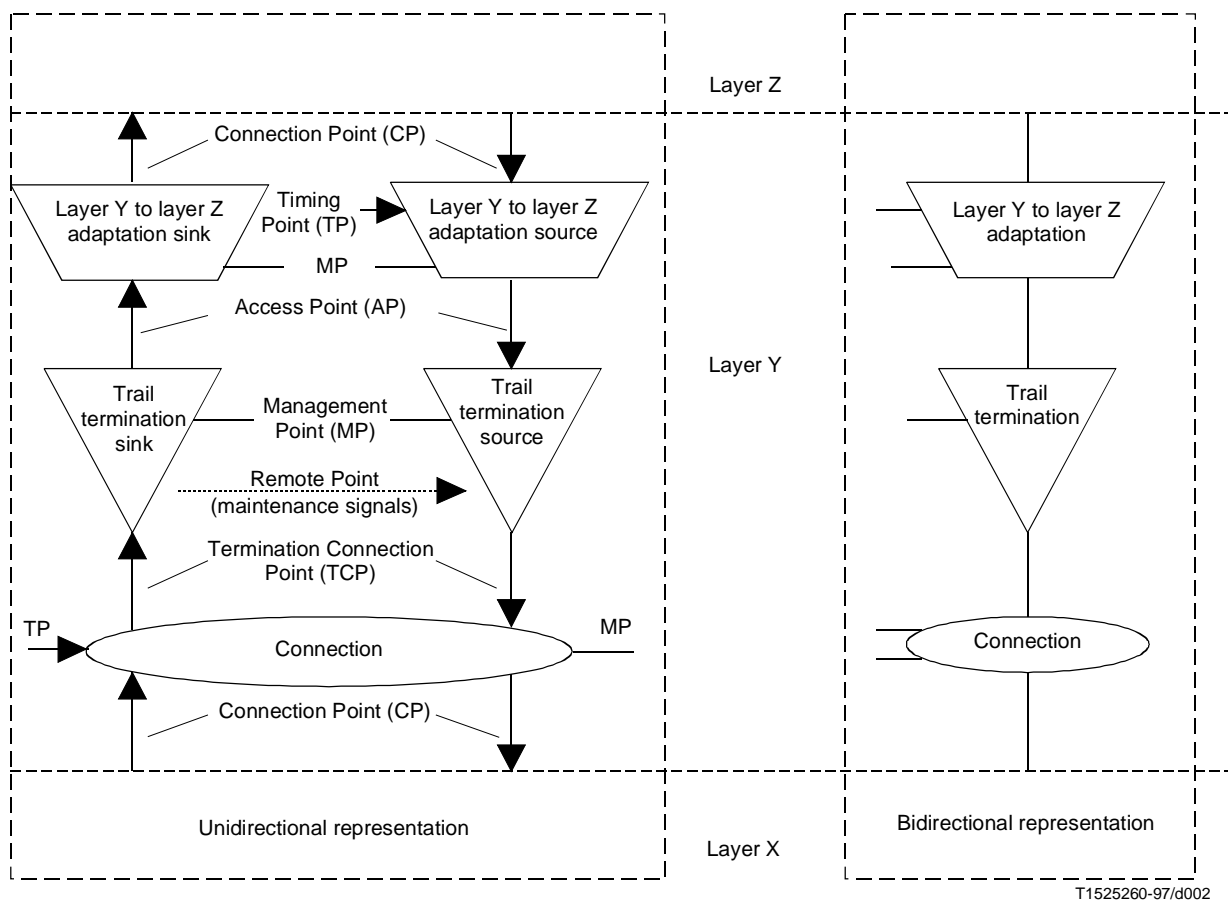

Figure 1-2/G.783 – Reference points in relation to atomic functions in a layer

Within the network each access point is uniquely identified by means of its Access Point Identifier (APId). See Recommendation G.831. The Termination Connection Point (TCP) – see Figure 1-2 – can be uniquely identified by means of the same APId. The Connection Point (CP) – see Figure 1-2 – can be uniquely identified by the APId extended with the multiplex number, e.g. the AU or TU number.

Example – A VC-12 CP (S12_CP) can be identified by means of the APId of the S4_AP, extended with the TU-12 TUG number (K, L, M).

1.5.2 Management reference point information naming

The coding of the **MI** signals follows the following rule:

<atomic function>_MI_<MI signal type>.

1.5.3 Timing reference point information naming

The coding of the **TI** signals follows the following rule:

<layer>_TI_<TI signal type: CK or FS>.

1.5.4 Remote reference point information naming

The coding of the **RI** signals follows the following rule:

<layer>_RI_<RI signal type: RDI, REI, ODI, or OEI>.

1.6 Atomic function naming and diagrammatic conventions

The naming of adaptation, trail termination and connection functions follows the following rules:

- Adaptation function <layer>/<client layer>_A[_<direction>]
- Trail termination function <layer>_TT[_<direction>]
- Connection function <layer>_C

Examples are – MS1/S4_A, S12/P12s_A_So, P4e_TT, RS16_TT_Sk, S3_C.

The diagrammatic conventions and nomenclature for adaptation, termination and connection functions (used to describe the atomic functions) are shown in Figure 1-3.

As an example of the use of this diagrammatic nomenclature, Figure 1-4 shows an example of a unidirectional VC-4 path in an SDH network.

As an example of the use of this diagrammatic nomenclature, Figure 1-5 shows an example of a transport level fragment of an Equipment Functional Specification (EFS).

The equipment represented by the EFS supports the following interfaces: two optical STM-4, one electrical STM-1, one 140 Mbit/s, a number of 2 Mbit/s.

The STM-4 interfaces contain the MS-DCC signal and SSM signal. The STM-4 interfaces can contribute to the synchronization reference selection process in synchronization layers.

NOTE 1 – RS-DCC, RS-USER, RS-OW and MS-OW signals are not supported by the STM-4 interfaces.

NOTE 2 – RS-DCC, RS-USER, RS-OW, MS-DCC, MS-OW and contribution to the synchronization reference selection process are not supported by the STM-1 interface. SSM is neither supported on the output STM-1 signal.

The 140 Mbit/s signal is asynchronous mapped into a VC-4.

NOTE 3 – VC4-USER signals are not supported by the VC-4 processing.

The 2 Mbit/s signal is either asynchronous or byte synchronous mapped into the VC-12.

The VC-4 matrix contains 12 inputs and outputs: three towards a VC-4 termination function and the other nine to MS_n to VC-4 adaptation functions.

NOTE 4 – Connectivity restrictions related to the VC-4 connection function are not represented in this presentation of the EFS. If applicable, connectivity restrictions can be presented in a further decomposed connection function representation, or by means of connectivity tables as shown in Appendix II.

NOTE 5 – The VC-4 connection function can support SNC protection switching. Such can be represented by means of a "rounded box" around the ellipse, as defined in Recommendation G.803.

Two VC-4 signals can be terminated when they contain a TUG structure with sixty-three TU-12s. The resulting 126 VC-12 signals are connected to the VC-12 connection function, that is also connected to a number of VC-12 termination functions.

NOTE 6 – Connectivity restrictions related to the VC-12 connection function are not represented in this presentation of the EFS. If applicable, connectivity restrictions can be presented in a further decomposed connection function representation, or by means of connectivity tables as shown in Appendix II.

NOTE 7 – The VC-12 connection function can support SNC protection switching. Such can be represented by means of a "rounded box" around the ellipse.

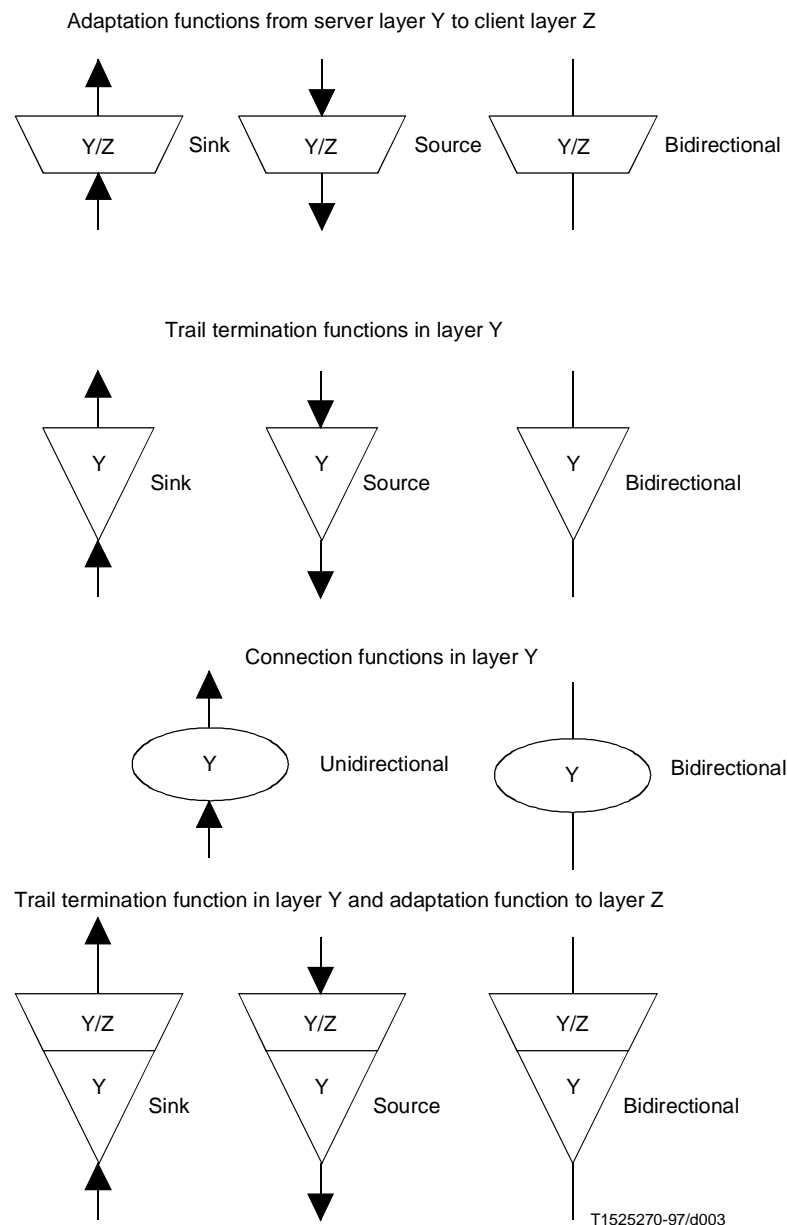

NOTE – If the above symbols are used for generic figures, i.e. not for specific layers, the layer references Y and Z may be omitted. Alternatively, the references may be to the type of function or layer, e.g. supervision, protection.

Figure 1-3/G.783 – Symbols and diagrammatic conventions

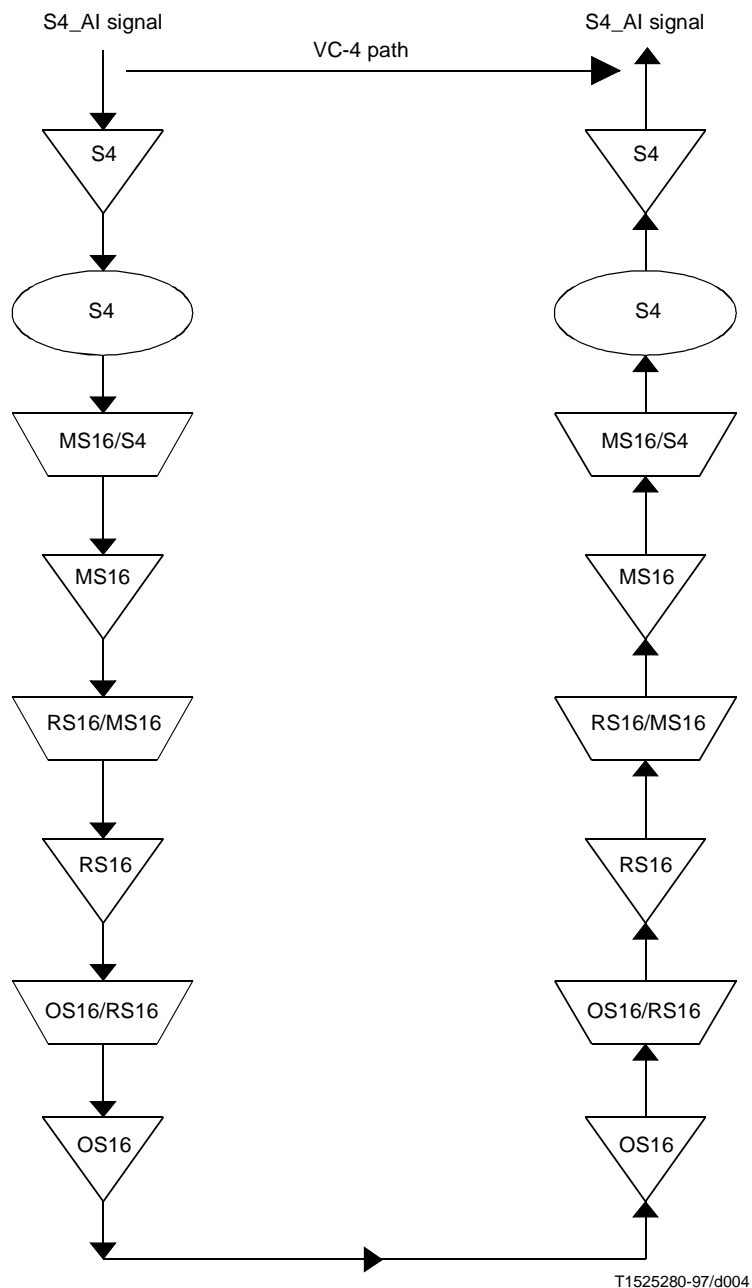

Figure 1-4/G.783 – Example of a unidirectional VC-4 path in an SDH network

Examples of possible connectivity are:

- a VC-4 from an STM-4 interface can be passed through to the other STM-4 interface, with or without time slot interchange;
- a VC-4 from an STM-4 interface can be passed through (or dropped) to the STM-1 interface;
- a VC-4 from an STM-4 interface can be terminated, making the 140 Mbit/s payload available at the 140 Mbit/s interface;
- a VC-4 from an STM-4 interface can be terminated, making the TUG payload accessible for further processing;
- a VC-12 from an STM-4 interface can be passed through to the other STM-4 interface, with or without time slot interchange between the VC-4 server signals;

- a VC-12 from an STM-4 or the STM-1 interface can be terminated (after VC-4 termination), making the 2 Mbit/s payload available at a 2 Mbit/s interface. Either asynchronous or byte synchronous mapping into the VC-12 is supported;
- a VC-12 from an STM-4 interface can be passed through (dropped) to the STM-1 interface (after VC-4 termination), with or without time slot interchange between the VC-4 server signals;
- VC-4 SNC/I protection could be supported between, for example, two VC-4s within the two STM-4 signals, or between an VC-4 within a STM-4 signal and the VC-4 in the STM-1 signal;
- VC-12 SNC/I protection could be supported between two VC-12s within the two TUG structured terminated VC-4 signals. These two VC-4 signals can come from the two STM-4 signals or one STM-4 signal and the STM-1 signal.

1.7 Atomic function process allocation

1.7.1 Connection function

The connection function provides flexibility within a layer. It may be used by the network operator to provide routing, grooming, protection and restoration.

NOTE – The connection function's flexibility process is modelled as a timing transparent switch, also referred to as "space switch". In equipment the switch matrix type may be either a "space switch" or a combination of "space and time switches". If a time switch is involved, the adaptation source functionality shall be located at the input of the switch matrix (connection function) rather than at the output (as in the functional model).

The location of the adaptation source functionality (i.e. elastic store and pointer generator) with respect to the connection functionality (i.e. switch matrix) is observable at the STM-N interface when the matrix connection is changed (e.g. due to SNC protection switch). A pointer with "enabled NDF" is generated when the adaptation source functionality is located at the output of the connection functionality. A pointer without "enabled NDF" is generated when the adaptation source functionality is located at the input of the connection functionality.

1.7.2 Trail termination function

The trail termination function performs the signal integrity supervision of the layer. In the source direction it generates and adds some or all of the following:

- error detection code [e.g. Bit Interleaved Parity (BIP), Cyclic Redundancy Check (CRC)];
- trail trace identifier (i.e. source address).

It conveys back the following remote information:

- remote error indicator signal (e.g. REI, OEI, E-bit), containing the number of detected error detection code violations in the received signal;
- remote defect indicator signal (e.g. RDI, ODI, A-bit), representing the defect status of the received signal.

In the sink direction, it monitors for some or all of the following:

- bit errors;
- (mis)connection;
- near-end performance;
- far-end performance;
- server signal fail [i.e. Alarm Indication Signal (AIS) instead of data];
- signal loss (disconnection, idle signal, unequipped signal).

NOTE – Functionality is reduced in the physical section layer termination functions, which can only monitor the signal loss. The physical section termination source function performs in addition logical/optical or logical/electrical conversion. The physical section termination sink function performs in addition optical/logical or electrical/logical conversion.

Bit errors are detectable via line code violations, parity violations or CRC violations; i.e. error detection code violations.

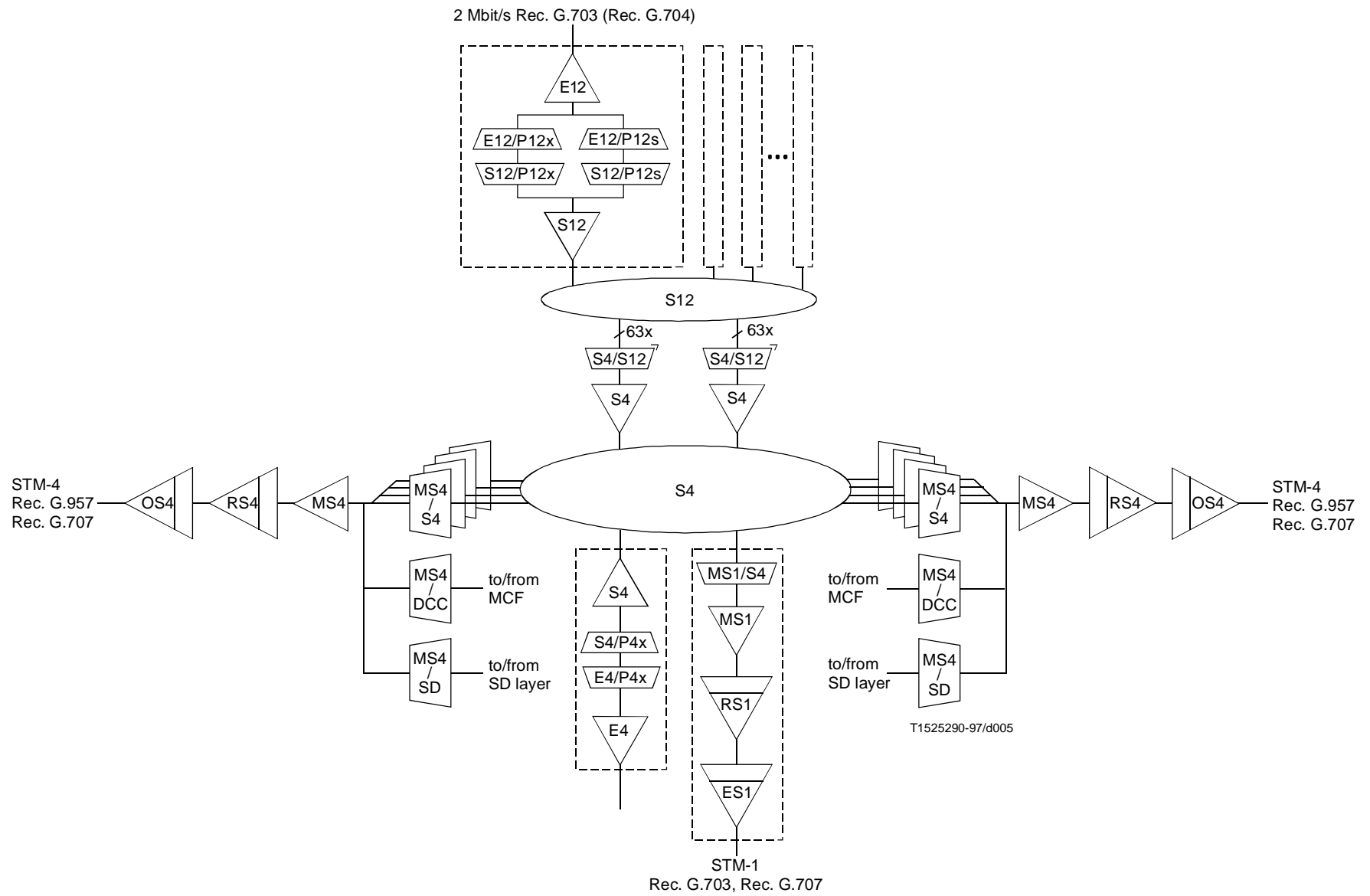

Figure 1-5/G.783 – Example of an SDH equipment functional specification

To monitor the provisioning of flexibility within an SDH network, Access Points (APs) will be identified (named/numbered). The APID is inserted in the signal, by the trail termination source function, in the Trail Trace Identifier (TTI). The trail termination sink function checks the received name/number with the expected one (provisioned by the network manager).

To enable single ended maintenance, the defect status and number of error detection code violations detected at the sink trail termination are conveyed back to the source trail termination; the defect status via the Remote Defect Indication (RDI) signal and the number of error detection code violations via the Remote Error Indication (REI) signal. The RDI and REI signals are part of the trail overhead.

Degradation of the signal results in the detection of anomalies and defects. As a consequent action of the detection of certain near-end defects, the signal is replaced by the all-ONES (AIS) signal and RDI is inserted in the return direction. The defects are reported to the fault management process.

The number of near-end block errors¹ per second is counted. The number of far-end block errors² per second is counted. A second is indicated as a near-end defect second in cases where a signal fail condition was detected in that second. A second is indicated as a far-end defect second in cases where an RDI defect was detected in that second.

Refer to the anomaly process description (see clause 2) for detailed specifications.

1.7.3 Adaptation function

An adaptation function represents the conversion process between a server and a client layer. One or more of the following processes may be present in an adaptation function:

- scrambling/descrambling;
- encoding/decoding;
- alignment (framing, pointer interpretation, FAS/PTR generation);
- bit-rate adaptation;
- frequency justification;
- multiplexing/demultiplexing;
- timing recovery;
- smoothing;
- payload identification;
- payload composition selection.

The **scrambling** process alters digital data in a predefined way to ensure the resulting bit stream has a sufficient density of 0 → 1 and 1 → 0 transitions to allow bit clock recovery from it. The **descrambling** process recovers the original digital data from the scrambled bit stream.

NOTE 1 – The scrambling/descrambling process would be adaptation processes. The historical definition of signals in existing standards causes a violation of this process allocation, hence the scrambling/descrambling processes are often located in the trail termination functions. Refer to the individual atomic functions for details.

The **encoding/decoding** process adapts a digital data stream to the characteristics of the physical medium over which it is meant to be transported. The **decoding** process recovers the original digital data from the medium specific form in which it is received.

The **alignment** process locates the first bit/byte of the framed signal [Frame Start (FS)] by means of a search for the Frame Alignment Signal (FAS) or the interpretation of the Pointer (PTR). If the FAS cannot be found or the PTR is corrupted for a specific period, an alignment defect is detected (LOF, LOP). The alignment defect may be the result of the reception of the all-ONES (AIS) signal. If so, the AIS defect is detected also. The defects are reported to the fault management layer/process.

¹ Detected by means of error detection code violation monitoring.

² Received via REI.

NOTE 2 – The insertion of a frame alignment signal would be an A_So process. The (historical) definition of the many signals in existing standards causes a violation of this process allocation, hence the frame alignment insertion process is often located in the TT_So function. Refer to the individual atomic functions for details.

The **bit-rate adaptation** process accepts input information at a certain bit rate and outputs that same information at a different bit rate. In the source direction, this process creates gaps in which other adaptation functions can add their signals. An example is the S12/P12s_A_So function; the 2 Mbit/s signal input to this function is output at a higher bit rate. The created gaps will be filled with the VC-12 POH.

The **frequency justification** process accepts an input information at a certain frequency and outputs that same information either at the same or at a different frequency. In the source direction, in order to accommodate any frequency (and/or phase) differences between input and output signals, this process may write data into a specific "justification" bit/byte in the outgoing frame structure when the elastic store (buffer) is going to overflow. It will skip data writing when the elastic store is going to underflow. Examples are the S4/S12_A_So and P4e/P31e_A_So functions.

NOTE 3 – The commonly used terms mapping and demapping are covered by bit-rate adaptation and frequency justification processes.

The **multiplexing/demultiplexing** process is modelled by means of multiple adaptation functions, connected to one AP (see 6.3). The information applied by the connected adaptation source functions ends up in pre-allocated time slots of the resulting time division multiplexed signal. Adaptation sink functions extract their associated adapted information from the common access point. Adaptation source/sink functions receive the necessary information allowing determination of correct write/read timing.

For the case multiple adaptation functions are connected to the same AP and accessing the same time slots (bits/bytes), a **selection** process controls the actual access to the AP. In the atomic functions this is modelled via the activation/deactivation signal (MI_active).

For the case only one adaptation function is present, it is selected. Control is not required.

The **timing recovery** process extracts a clock signal, the "recovered clock", from the incoming data signal. The timing recovery process is performed in the adaptation sink function in the physical section layer; e.g. in OS16/RS16_A_Sk.

The **smoothing** process filters the phase step of "gapped input signals". The smoothing process is performed in the adaptation sink functions; e.g. in Sm/Xm_A_Sk, Pn/Pm_A_Sk.

Many layers are able to transport a variety of client signals applied to the layer via different adaptation functions. To monitor the provisioning process the source Adaptation inserts the appropriate code in the Trail Signal Label (TSL). The sink adaptation will check the **composition of the payload** comparing the received TSL number with its own one.

1.8 Combination rules

1.8.1 General

In general, any functions which share the same characteristic or adapted information may be combined.

1.8.2 Binding at connection points

The connection point input (output) of an adaptation function may be bound to the connection point output (input) of either a connection function or an adaptation function, as shown in Figure 1-6.

Example – An S12_CP of an S12_C function may be connected to an S12_CP of an S4/S12_A function.

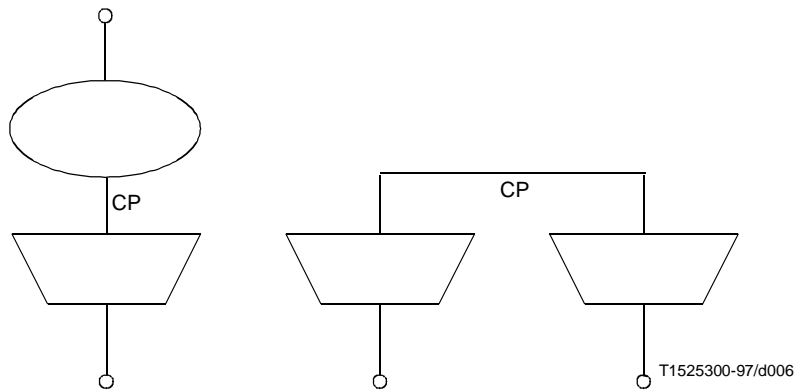

Figure 1-6/G.783 – Binding of connection points (CP-CP binding)

1.8.3 Binding at (termination) connection points

The termination connection point output (input) of a trail termination function may be bound to the connection point input (output) of either an adaptation function or a connection function or the termination connection point input (output) of a trail termination function, as shown in Figure 1-7.

NOTE – Once bound, the CP and TCP are referred to as a termination connection point.

Example – An S12_TCP of an S12_TT function may be connected to an S12_CP of an S12_C function.

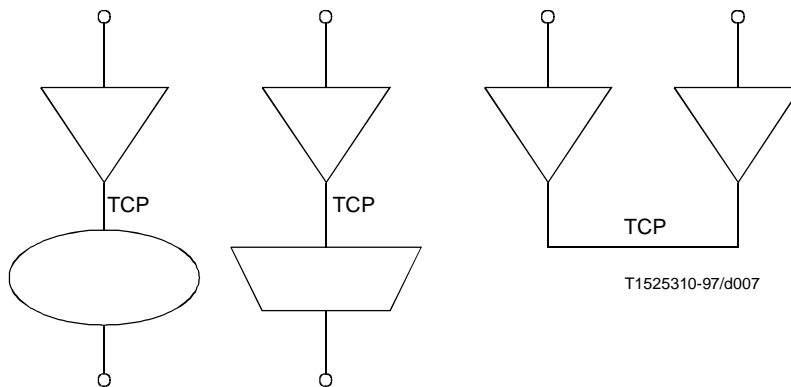

Figure 1-7/G.783 – Binding involving a termination connection point (TCP-CP and TCP-TCP binding)

1.8.4 Binding at access points

The AP input (output) of a trail termination function may be bound to the AP output (input) of an adaptation function as shown in Figure 1-8.

Example – An S4_AP of an S4/S12_A function may be connected to an S4_AP of an S4_TT function.

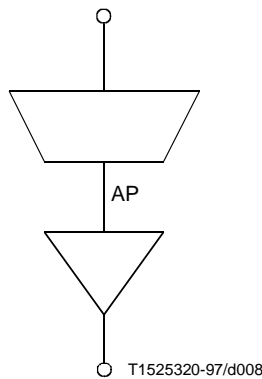

Figure 1-8/G.783 – Binding of access points (AP-AP binding)

1.8.5 Alternative binding representations

The binding at reference points can continue, according to the above rules, and create a path such as the one shown in Figure 1-9.

NOTE – The binding at reference points may also be represented as illustrated in Figure 1-9. In an equipment functional specification, the explicit reference to the reference points is not required if the atomic functions are named. In such a case, the names of the reference points are obvious.

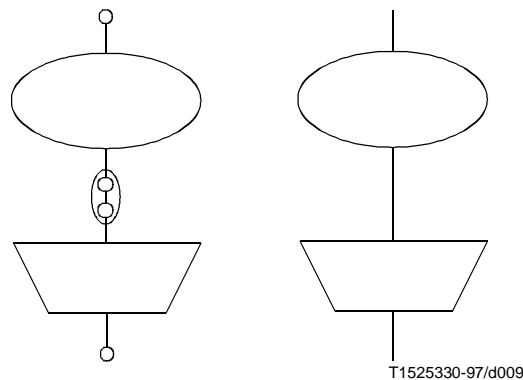

Figure 1-9/G.783 – Alternative binding representation

1.8.6 Directionality

One source atomic function and one sink atomic function, with their associated RDI/REI maintenance channels connected may be associated as a bidirectional pair (when a function is referred to without the directionality qualifier it can be taken to be bidirectional). Bidirectional servers may support bidirectional or unidirectional clients but unidirectional servers may only support unidirectional clients.

1.8.7 Compound functions

Combinations of atomic functions in one or more layer(s) may be identified by a special symbol, a compound function. Three examples are shown in Figures 1-10, 1-11 and 1-12.

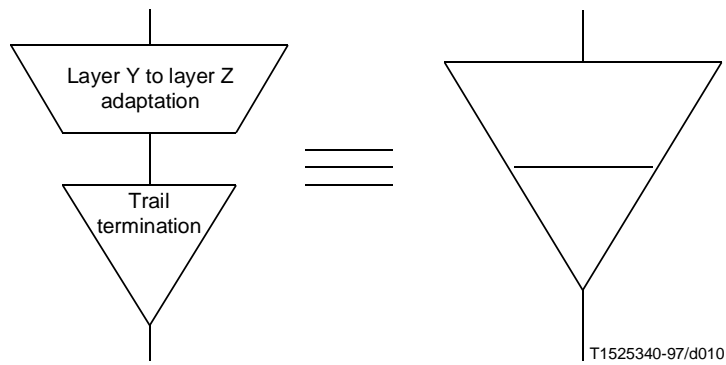

Figure 1-10/G.783 – Compound termination/adaptation function

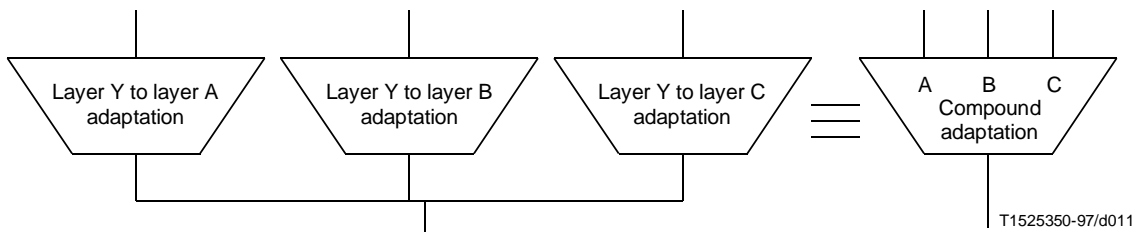

Figure 1-11/G.783 – Compound adaptation function

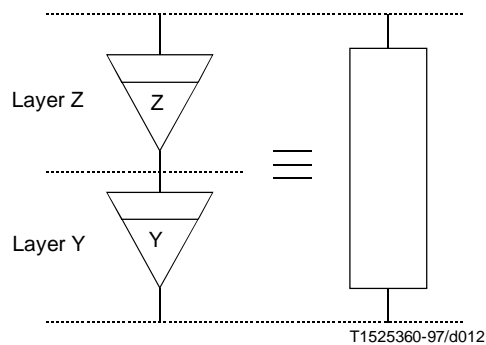

Figure 1-12/G.783 – Compound function spanning multiple layers

1.9 Fault management and performance monitoring naming

The naming of supervision variables follow the following rules:

The supervision variables are defined as "yZZZ", with:

- y defect: y = d
- fault cause (i.e. correlated defect): y = c
- failure: y = f
- consequent action request: y = a
- performance parameter: y = p
- anomaly: y = n

ZZZ kind of defect, fault cause, failure, consequent action, performance parameter or command.

dZZZ, cZZZ, and fZZZ represent Boolean variables with states TRUE or FALSE. pZZZ represents an integer variable. aZZZ, except aREI, represents a Boolean variable; aREI represents an integer variable.

1.10 Fault management and performance monitoring specification techniques

The defect correlation and consequent action specifications make use of the following supervision equation techniques:

- $aX \leftarrow A \text{ or } B \text{ or } C$
- $cY \leftarrow D \text{ and } (\text{not } E) \text{ and } (\text{not } F) \text{ and } G$
- $pZ \leftarrow H \text{ or } J$

"aX" represents the control of consequent action "X". The associated consequent action will be performed if the boolean equation "A or B or C" is true. Otherwise, if the equation is false, the consequent action will not be performed. Consequent actions are e.g.: insertion of all-ONEs (AIS) signal, insertion of RDI signal, insertion of REI signal, activation of signal fail or signal degrade signals.

"cY" represents the fault cause "Y" which is (will be) declared if the boolean expression "D and (not E) and (not F) and G" is true. Otherwise (expression is false), the fault cause is (will be) cleared. MON will often be a term in this equation (see 2.2.1).

"pZ" represents the performance monitoring primitive "Z" which value at the end of a one second period represents the number of errored blocks (or error detection code violations) or the occurrence of a defect in that second.

"A" to "H" represent either defects (e.g. dLOS), reporting control parameters (e.g. AIS_Reported), consequent actions (e.g. aTSF), or the number of errored blocks over a one second period (e.g. ΣnN_B).

NOTE – Hardware faults causing signal transfer interruption are represented by "dEQ". Such faults contribute to the near-end performance monitoring primitive pN_DS.

1.11 Performance and reliability

1.11.1 Transit delay

To derive the total transit delay of a signal through an SDH network element, all processes which could contribute non-negligible delay must be taken into account. Since it is only possible to measure transit delay from NNI to NNI, that value is the only one which must be derived.

The contributing processes which have been identified to date are:

- Pointer buffer processing. (A distinction could be made between pointer buffer threshold spacing and pointer adjustment processes.)
- Fixed stuff processing. SOH and POH could be regarded as fixed stuffing for a particular VC level.
- Processing which is implementation-dependent, e.g. internal interface processing.
- Connection processing.
- Mapping processing.
- Demapping processing.

Depending on NNIs and processing levels, various of the above-mentioned processes must be taken into account. The total delay is then calculated as the sum of the processes involved. These values could be given as minimum, average, or maximum values under normal operating conditions or in worst case failure scenarios.

Another parameter associated with delay is the differential transit delay of path signals within the same server trail.

NOTE – Specifications of transit delay and differential transit delay are outside the scope of this Recommendation.

1.11.2 Response times

Matrix set-up delay is the time taken from generation of primitive within the SEMF to the change of transport information at NNI. It may be necessary to distinguish between preset configurations, subject to an execute primitive and a normal set.

Message processing delay is the time from the end of message at Q until the primitive is generated within the SEMF; i.e. the message has been decoded to an actionable level.

NOTE – Specifications of response times are outside the scope of this Recommendation.

1.11.3 Availability and reliability

For a network provider, the reliability of network elements is of prime concern as it directly influences the availability of connections. However, the availability of a connection depends not only on the reliability of the network elements themselves but also on the level of network redundancy. Furthermore, it depends on the restoration times of the equipment involved. The restoration times depend to a great extent on the Operation, Administration and Maintenance (OAM) philosophy of the network provider.

A manufacturer has, in most cases, requirements from several operators to take into account. Requirements from a certain network provider will depend on the level of economic development of the country concerned, the degree of market competition, customer requirements, the level of network redundancy, the level of maintenance support, etc.

The basis for determining the availability of a network element should be the analytical method for dependability as described in Recommendation E.862.

The main point of the analytical method is that dependability aspects are taken into account as an economic factor. The level of availability is thus dimensioned according to cost-benefit analyses rather than by beforehand stated objectives.

The application of the method to network components is shown in the ITU-T Handbook "Handbook on Quality of Service and Network Performance".

Calculation of Mean Time Between Failure (MTBF) values based on Failure In Time (FIT) values should use the methodology described in Recommendation G.911.

NOTE – Availability and reliability specifications for SDH network elements and trail/connections are outside the scope of this Recommendation.

2 Supervision processes and management information flows

The information flows described in this clause are functional and defined at the internal MP reference point. Information received via the TMN may be pre-processed by the SEMF before it is forwarded to an MP reference point. Information received via an MP reference point may be post-processed by the SEMF before it is forwarded to the TMN interface.

The generic information flow and its related processing is described hereafter.

2.1 Information flow (XXX_MI) across the XXX_MP reference points

Table 2-1 summarizes the generic (superset) of configuration, provisioning and reporting information (MI) that is passed across the XXX_MP reference points for the three types of atomic functions. The information listed under Input ("Set") in this table refers to configuration and provisioning data that is passed from the SEMF to the other functional blocks. The information listed under Output ("Get") refers to (autonomous) status reports to the SEMF from the atomic functions.

NOTE – The configuration, provisioning and reporting information for a specific atomic function is listed in the I/O table in the atomic function specification itself.

As an example we may consider the higher order path trace. The higher order path termination sink function may be provisioned for the HO path trace for what it should expect by an "MI_ExTI" command received from the manager. If the HO path trace that is received does not match the expected HO path trace, this will give rise to a report of a mismatch of the HO path trace across the S_n _TT_MP reference point (MI_cTIM). Having received this mismatch indication, the relevant managed object may then decide to request a report of the HO path trace ID that has been received by an "MI_AcTI" report.

Table 2-1/G.783 – Generic command, configuration, provisioning and reporting information flow over the XXX_MP reference points

Management point	Process within atomic function	Input ("Set")	Output ("Get")
TT_So_MP	Transmitter		Transmit signal fail fault cause (MI_cTF) Transmit signal degrade fault cause (MI_cTD)
	Trace identifier	Transmitted trail trace identifier (MI_TxTI) value	
TT_Sk_MP	Termination point/port mode	Termination point mode control (MI_TPmode: MON, <u>NMON</u>) Port mode control (MI_Portmode: MON, (AUTO), <u>NMON</u>)	
	Signal presence		Signal loss fault cause (MI_cLOS, MI_cUNEQ)
	Trace identifier	Expected trail trace identifier (MI_ExTI) value Misconnected traffic defect detection control (MI_TIMdis: true, <u>false</u>)	Accepted (received) trail trace identifier value (MI_AcTI) Misconnected traffic fault cause (MI_cTIM)
	Bit error monitoring	Poisson based excessive defect threshold selection (MI_EXC_X: <u>10⁻³</u> , 10 ⁻⁴ , 10 ⁻⁵) Poisson based degraded defect threshold selection (MI_DEG_X: 10 ⁻⁵ , <u>10⁻⁶</u> , 10 ⁻⁷ , 10 ⁻⁸ , 10 ⁻⁹) Burst based degraded defect interval threshold selection (MI_DEGTHR: 0.. <u>(30)</u> ..100%) (Note 1) Burst based degraded defect monitor period selection (MI_DEGM: 2.. <u>10</u>)	Poisson based excessive errors fault cause (MI_cEXC) Poisson based degraded errors fault cause (MI_cDEG) Burst based degraded errors fault cause (MI_cDEG)
	AIS monitoring and reporting	AIS fault cause reporting control (MI_AIS_Reported: true, <u>false</u>)	AIS fault cause (MI_cAIS)
	RDI monitoring and reporting	RDI fault cause reporting control (MI_RDI_Reported: true, <u>false</u>)	RDI fault cause (MI_cRDI)
	ODI monitoring and reporting	ODI fault cause reporting control (MI_ODI_Reported: true, <u>false</u>)	ODI fault cause (MI_cODI)
	Performance monitoring	1 second period indications (MI_1second)	Performance monitoring primitives (MI_pN_EBC, MI_pN_DS, MI_pF_EBC, MI_pF_DS, ...)
A_So_MP	Selection	Payload composition selection (MI_Active: true, <u>false</u>)	
	Performance monitoring		Performance monitoring justification actions (MI_pPJC+, MI_pPJC-)

Table 2-1/G.783 – Generic command, configuration, provisioning and reporting information flow over the XXX_MP reference points (concluded)

Management point	Process within atomic function	Input ("Set")	Output ("Get")
A_Sk_MP	Selection	Payload composition selection (MI_Active: true, <u>false</u>)	
	AIS monitoring and reporting	AIS fault cause reporting control (MI_AIS_Reported: true, <u>false</u>)	AIS fault cause (MI_cAIS)
	Payload monitoring		Accepted (received) payload type value (MI_AcSL) Miscomposed traffic fault cause (MI_cPLM)
	Frame alignment		Alignment loss fault cause (MI_cLOF, MI_cLOM, MI_cLOP)
C_MP	Connection management	Matrix connection selection	
	protection	Protection group selection (set of connection points, protection architecture: 1+1/1:n/m:n, switching type: uni/bidirectional, operation type: revertive/non-revertive, APS usage: true/false, extra traffic: true/false) External switch commands (MI_EXTCMD: LO, FS, MS, EXER, CLR) External control command (LOW) HoldOff time value (MI_HOtime) WaitToRestore value (MI_WTRtime: 0.. <u>5</u> ..12 minutes)	Protocol fault cause (MI_cFOP) Performance monitoring protection switch actions (MI_pPSC) Performance monitoring protection switched seconds (MI_pPSSw, MI_pPSSp) Protection status (for further study)
NOTE 1 – The granularity for the degraded defect threshold selection is for further study. See 2.2.2.5.2.			
NOTE 2 – Underscored values are suggested defaults.			

2.2 Supervision

Transmission and equipment supervision processes are concerned with the management of the transmission resources in the network, and they are only interested in the functionality which is being provided by a Network Element (NE). They require a functional representation of an NE that is implementation-independent.

The supervision process describes the way in which the actual occurrence of a disturbance or fault is analysed with the purpose of providing an appropriate indication of performance and/or detected fault condition to maintenance personnel. The following terms are used to describe the supervision process: anomaly, defect, consequent action, fault cause, failure and alarm. Supervision terms and variables used throughout this Recommendation are defined in 1.3.

Any equipment faults are represented by the unavailability of the affected functions because the transmission management has no knowledge of the equipment as such. Most functions monitor the signals they are processing for certain characteristics and provide performance information or alarm conditions based on these characteristics. Therefore, transmission supervision processing provides information on the external interface signals that are processed by an NE.

The supervision processes and their inter-relationships within atomic functions are depicted in Figures 2-1 and 2-2. The inter-relationships between the supervision processes in atomic functions and the equipment management function is specified in clause 5/G.784.

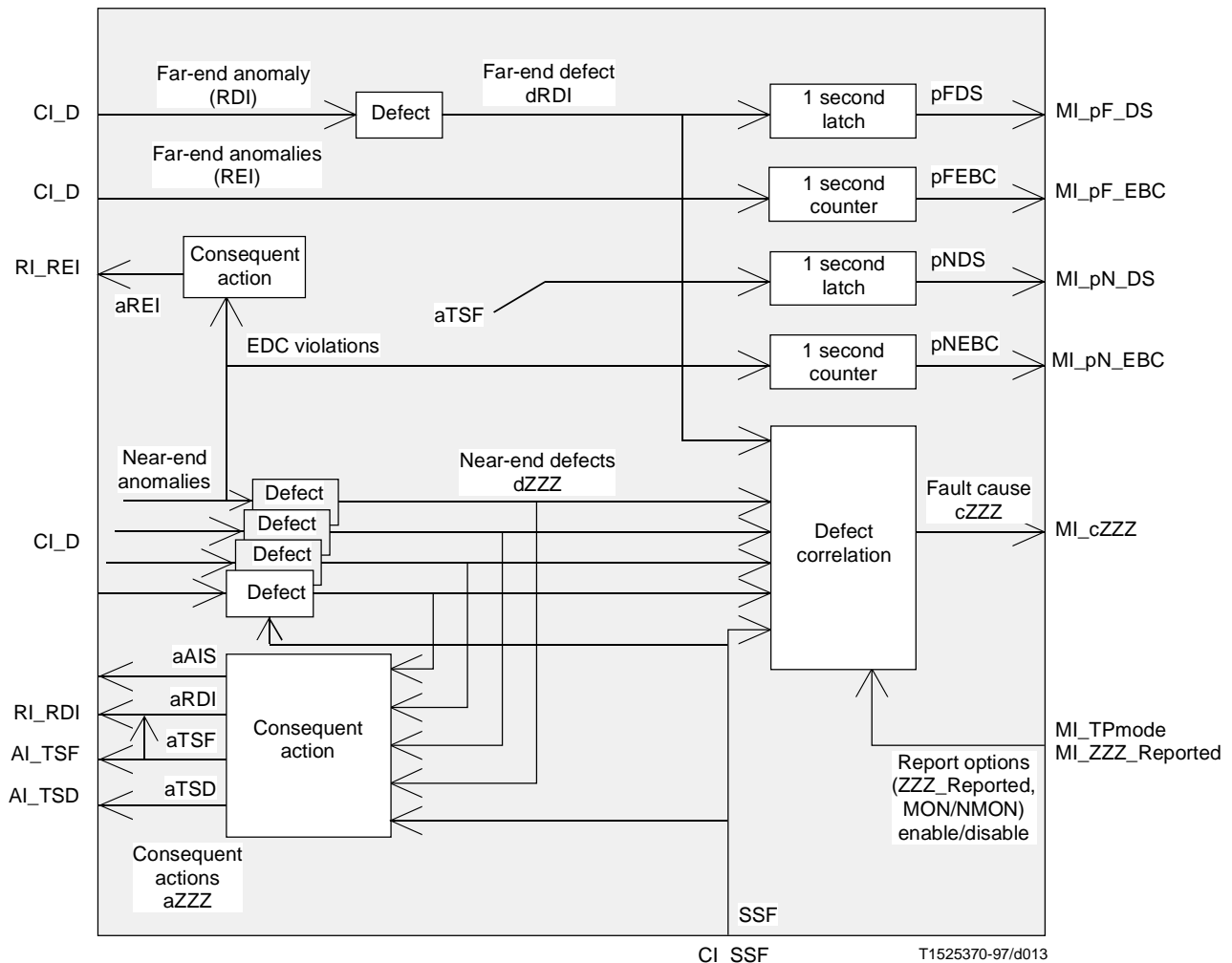

Figure 2-1/G.783 – Supervision process within trail termination functions

The filtering functions provide a data reduction mechanism within atomic functions on the anomalies and defects before being presented at the XXX_MP reference points. Four types of techniques can be distinguished:

- trail termination point and port modes;
- one second integration;
- defect detection;
- fault management and performance monitoring correlations.

2.2.1 Trail termination point mode and port mode

To prevent alarms from being raised and failures being reported during trail provisioning actions, trail termination functions shall have the ability to enable and disable fault cause declaration. This shall be controlled via their termination point mode or port mode parameter.

The termination point mode (see Figure 2-3) shall be either "monitored" (MON) or "not monitored" (NMON). The state shall be MON if the termination function is part of a trail and provides service, and NMON if the termination function is not part of a trail or is part of a trail which is in the process of set-up, break-down or re-arrangement.

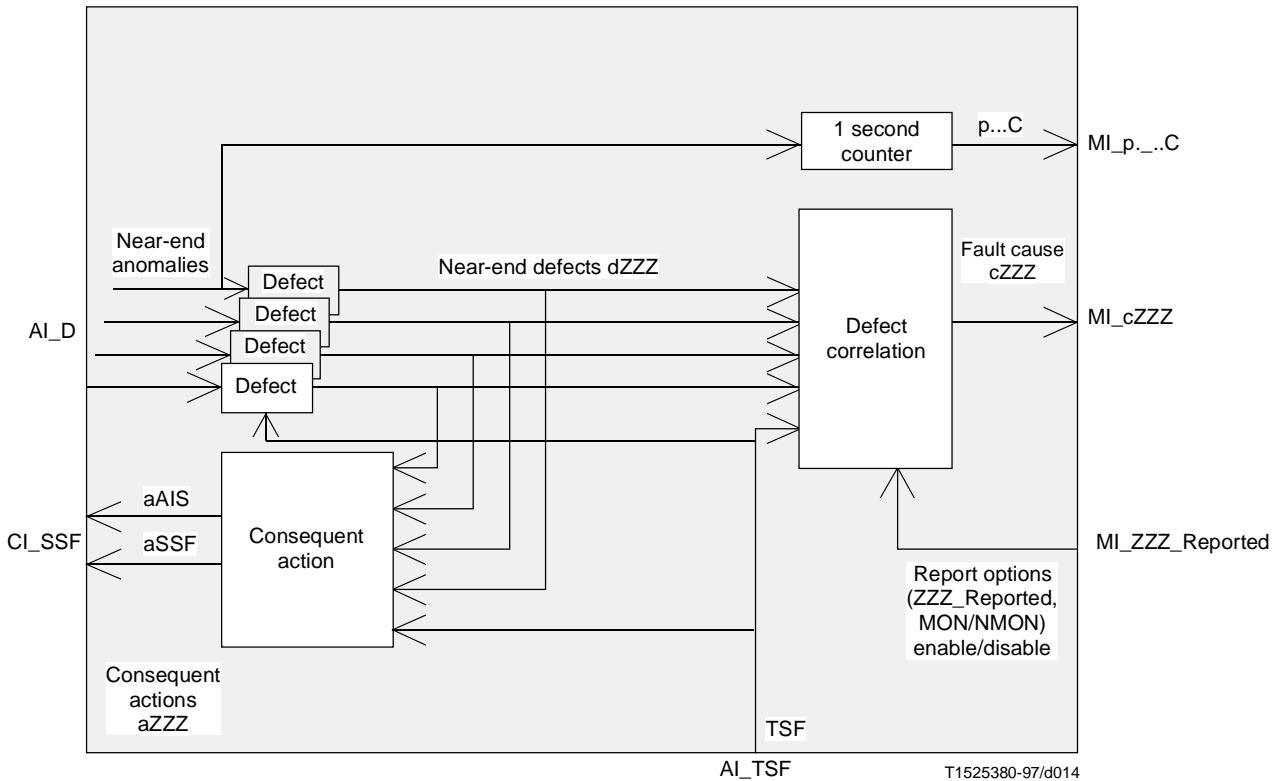

Figure 2-2/G.783 – Supervision process within adaptation functions

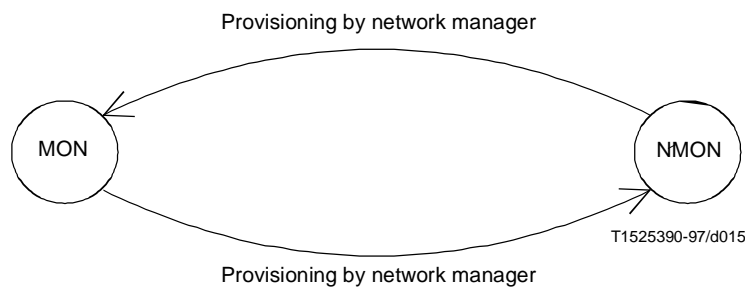

Figure 2-3/G.783 – Trail termination point modes

In physical section layers, the termination point mode is called the port mode. It has three modes (Figure 2-4): MON, AUTO, and NMON. The AUTO mode is like the NMON mode with one exception: if the LOS defect clears, the port mode is automatically changed to MON. This allows for alarm-free installation without the burden of using a management system to change the monitor mode. The AUTO mode is optional. When it is supported, it shall be the default mode; otherwise, NMON shall be the default mode.

2.2.2 Defect filter

The (anomaly to) defect filter will provide a persistency check on the anomalies that are detected while monitoring the data stream; when passed, the defect is being detected. Since all of the defects will appear at the input of the defect correlation filter (Figures 2-1 and 2-2) it provides correlation to reduce the amount of information offered as failure indications to the SEMF. See 2.2.4.

In addition to the transmission fault causes listed in Table 2-1, hardware faults with signal transfer interruption are also reported at the input of the defect filter for further processing.

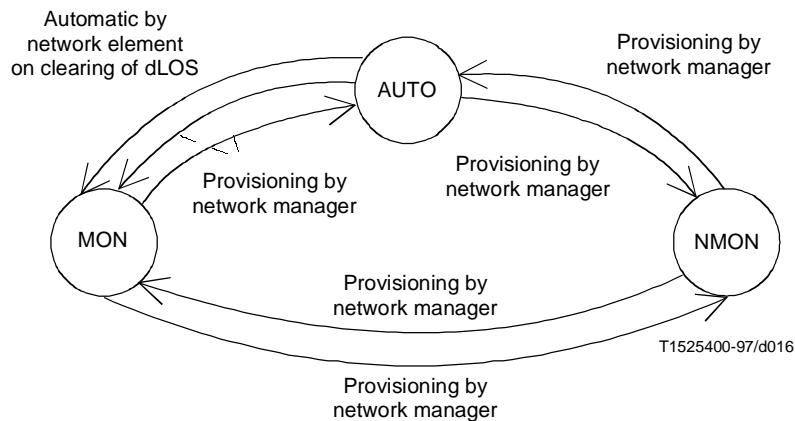

Figure 2-4/G.783 – Port modes

2.2.2.1 Loss Of Signal defect (dLOS)

STM-N optical interfaces: See Recommendation G.958.

STM-1 electrical interfaces: Similar to the specification for 140 Mbit/s signals in Recommendation G.775.

PDH G.703 interfaces: See Recommendation G.775.

2.2.2.2 Signal label processing: unequipped defect (dUNEQ)

Basic function sink direction

Byte C2/bits V5[5-7] signal label (TSL) is recovered from the CP.

VC-3, VC-4: The unequipped defect (dUNEQ) shall be detected if five consecutive VC-*n* (*n* = 3, 4) frames contain the "00000000" pattern in byte C2. The dUNEQ defect shall be cleared if in five consecutive VC-*n* frames any pattern other than the "00000000" is detected in byte C2.

VC-11, VC-12, VC-2: The unequipped defect (dUNEQ) shall be detected if five consecutive VC-*m* (*m* = 11, 12, 2) frames contain the "000" pattern in bits 5 to 7 of byte V5. The dUNEQ defect shall be cleared if in five consecutive VC-*m* frames any pattern other than the "000" is detected in bits 5 to 7 of byte V5.

NOTE – Some regional standards require a burstproof algorithm of the UNEQ defect.

2.2.2.3 Signal label processing: VC-AIS defect (dAIS)

Basic function sink direction

Byte C2/bits V5[5-7] signal label (TSL) is recovered from the CP.

VC-3, VC-4: The VC-AIS defect will be detected by monitoring byte C2 for code "all-ONES". If five consecutive frames contain the "all-ONES" pattern in C2, the dAIS defect shall be declared. dAIS shall be cleared if in five consecutive frames any pattern other than the "all-ONES" is detected in C2.

VC-11, VC-12, VC-2: The VC-AIS defect will be detected by monitoring bits 5 to 7 of byte V5 for code "all-ONES". If five consecutive frames contain the "all-ONES" pattern in V5[5-7], the dAIS defect shall be declared. dAIS shall be cleared if in five consecutive frames any pattern other than the "all-ONES" is detected in the V5[5-7].

NOTE 1 – Equipment designed prior to this Recommendation may be able to perform VC-AIS detection either as specified above with "frames" being replaced by "samples (not necessarily frames)", or by a comparison of the accepted signal label with the all-ones pattern. If the accepted signal label is not equal to all-ones, the VC-AIS defect is cleared.

NOTE 2 – In networks that do not support/allow the transport of VC-*n*/VC-*m* signals with tandem connection overhead, VC-AIS defect is not defined and VC-AIS defect is assumed to be false.

2.2.2.4 Trail trace identifier processing and Trace Identifier Mismatch defect (dTIM)

Basic function source direction

The generation of Trail Trace Identifier (TTI) is optional and in the province of regional standards.

For the case TTI generation is not required, the contents of the J0/J1/J2 byte is not configurable.

NOTE 1 – In order to distinguish between unequipped and supervisory unequipped, the fixed code 00000000 in J1/J2 should not be used in the supervisory unequipped termination source function.

For the case TTI generation is required, the TTI information derived from the management reference point (MI_TxTI) is placed in the J0/J1/J2 byte position.

Basic function sink direction

Byte J0/J1/J2 trail trace identifier (TTI) is recovered from the CP.

The detection of a Trace Identifier Mismatch defect (dTIM) is optional and in the province of the regional standards.

For the case dTIM detection is not required, the receiver shall be able to ignore the received J0/J1/J2 values, and dTIM is considered "false".

For the case dTIM detection is required, the following applies: The detection of dTIM is based on a comparison between the expected TTI, configured via the management reference point (MI_ExTI), and the accepted TTI (AcTI). If dTIM detection is disabled via an input ("Set") command (MI_TIMdis) at the management reference point, then dTIM is considered "false".

NOTE 2 – Acceptance criteria and defect specification for the TTI is for further study to ensure integrity, and robustness to errors for TIM.

NOTE 3 – A mismatch in the CRC-7 or TFAS signal of the 16-byte trace identifier results in the detection of the dTIM defect.

The accepted TTI shall be reported via the management point (MI_AcTI) to the SEMF.

SEMF interface

J0: A TTI received by the SEMF via the V reference point is a 1- or 16-byte string. The handling of a string shorter than 16 bytes is for further study.

J1: A TTI received by the SEMF via the V reference point is a 16- or 64-byte string. The handling of a string shorter than 16 or 64 characters, respectively, is for further study.

J2: A TTI received by the SEMF via the V reference point is a 16-byte string. The handling of a string shorter than 16 characters is for further study.

If the expected TTI received by the SEMF is NULL, the TIM disable command at the management reference point is set to "true"; otherwise, the TIM disable command (MI_TIMdis) is set to "false" for the corresponding atomic function.

NOTE 4 – Expected TTI NULL is a special value (empty string). It is not a 1-, 16- or 64-byte string with "0" characters or binary "0000 0000".

2.2.2.5 Excessive error and degraded signal defects (dEXC, dDEG)

For networks where the network operator assumes a *Poisson distribution of errors*, an excessive error defect and a degraded signal defect are to be detected.

For networks where the operator assumes a *bursty distribution of errors*, a degraded signal defect is to be detected. The excessive error defect, for this case, is assumed to be false.

The applicability of the two is in the province of the regional standards.

2.2.2.5.1 Excessive error and degraded signal defects assuming Poisson distribution of errors

Excessive error and degraded signal defects are to be detected according to the following process:

An excessive error defect (dEXC) shall be detected if the equivalent BER exceeds a preset threshold of 10^{-x} , $x = 3, 4$ or 5. The excessive error defect shall be cleared if the equivalent BER is better than $10^{-(x+1)}$.

With $BER \geq 10^{-x}$ the probability of defect detection within the measuring time shall be ≥ 0.99 .

With $BER \leq 10^{-(x+1)}$ the probability of defect detection within the measuring time shall be $\leq 10^{-6}$.

With $BER \geq 10^{-x}$ the probability of defect clearing within the measuring time shall be $\leq 10^{-6}$.

With $BER \leq 10^{-(x+1)}$ the probability of defect clearing within the measuring time shall be ≥ 0.99 .

A degraded signal defect (dDEG) shall be detected if the equivalent BER exceeds a preset threshold of 10^{-x} , $x = 5, 6, 7, 8$ or 9 . The degraded signal defect shall be cleared if the equivalent BER is better than $10^{-(x+1)}$.

With $BER \geq 10^{-x}$ the probability of defect detection within the measuring time shall be ≥ 0.99 .

With $BER \leq 10^{-(x+1)}$ the probability of defect detection within the measuring time shall be $\leq 10^{-6}$.

With $BER \geq 10^{-x}$ the probability of defect clearing within the measuring time shall be $\leq 10^{-6}$.

With $BER \leq 10^{-(x+1)}$ the probability of defect clearing within the measuring time shall be ≥ 0.99 .

Maximum detection and clearing time requirements for the BER calculations are listed in Table 2-2.

NOTE – The specification in the previous revision of this Recommendation could have been interpreted as listed in Table 2-3.

2.2.2.5.2 Excessive error and degraded signal defects assuming bursty distribution of errors

The excessive error defect is not defined, and dEXC is assumed to be false.

The degraded signal defect (dDEG) shall be declared if DEGM consecutive bad intervals (interval is the 1 second period used for performance monitoring) are detected. An interval is declared bad if the percentage of detected errored blocks in that interval \geq degraded threshold (DEGTHR). The granularity for provisioning of the DEGTHR is for further study since, for higher rate interfaces, one per cent is equal to a large number of blocks per frame. For example, in an STM-16 interface, 1% is equal to a step of 30 720 blocks/frame. One proposal has been to allow provisioning the DEGTHR as a number of errored blocks rather than a percentage.

NOTE – For the case of dDEG in the MS_n layer, the errored block is equal to a BIP violation.

The degraded signal defect shall be cleared if M consecutive good intervals are detected. An interval shall be declared good if the percentage of detected errored blocks in that interval $<$ DEGTHR.

The parameter DEGM shall be provisionable in the range 2 to 10. The parameter DEGTHR shall be in the range $0 < DEGTHR \leq 100\%$.

2.2.2.6 Remote defect indication processing and Remote Defect Indication defect (dRDI)

Basic function source direction

The generation of RDI is required for bidirectional trail termination functions. The value inserted is the value received via RI_RDI from the associated basic sink function.

NOTE 1 – For unidirectional trail termination functions not being paired with a termination sink function, the RDI signal output should be inactive, but can be undefined in old equipment not explicitly supporting unidirectional transport.

NOTE 2 – For the case of STM-16/STM-64 MS-RDI, the above specification should be enhanced to support the use of these bits for MS SPring APS during inactive RDI periods. For the case of higher and lower order path RDI, the above specification should be enhanced to support the use of these bits for the transport of "RDI-LCD" as defined in Recommendation G.707. This is for further study.

Basic function sink direction

Bits K2[6-8] are recovered from the CP for the case of an MS_n_CP . Bit G1[5]/V5[8] is recovered from the CP for the case of an S_n_CP/S_m_CP .

MS_n : If z consecutive STM-N frames contain the pattern "110" in K2[6-8], a dRDI defect shall be detected. The dRDI defect shall be cleared if z consecutive STM-N frames contain any pattern other than "110" in K2[6-8]. z is in the range of 3 to 5. z is not configurable.

Table 2-2a/G.783 – Maximum detection time requirements for VC-4 and VC-3

Detector threshold	Actual BER						
	$\geq 10^{-3}$	10^{-4}	10^{-5}	10^{-6}	10^{-7}	10^{-8}	10^{-9}
10^{-3}	10 ms						
10^{-4}	10 ms	100 ms					
10^{-5}	10 ms	100 ms	1 s				
10^{-6}	10 ms	100 ms	1 s	10 s			
10^{-7}	10 ms	100 ms	1 s	10 s	100 s		
10^{-8}	10 ms	100 ms	1 s	10 s	100 s	1000 s	
10^{-9}	10 ms	100 ms	1 s	10 s	100 s	1000 s	10 000 s

Table 2-2b/G.783 – Maximum detection time requirements for VC-2, VC-12 and VC-11

Detector threshold	Actual BER					
	$\geq 10^{-3}$	10^{-4}	10^{-5}	10^{-6}	10^{-7}	10^{-8}
10^{-3}	40 ms					
10^{-4}	40 ms	400 ms				
10^{-5}	40 ms	400 ms	4 s			
10^{-6}	40 ms	400 ms	4 s	40 s		
10^{-7}	40 ms	400 ms	4 s	40 s	400 s	
10^{-8}	40 ms	400 ms	4 s	40 s	400 s	4000 s

Table 2-2c/G.783 – Clearing time requirements

Detector threshold	Set/clear values associated with detector threshold	Multiplex section VC-4 VC-3	VC-2 VC-12 VC-11
10^{-3}	$10^{-3}/10^{-4}$	10 ms	40 ms
10^{-4}	$10^{-4}/10^{-5}$	100 ms	400 ms
10^{-5}	$10^{-5}/10^{-6}$	1 s	4 s
10^{-6}	$10^{-6}/10^{-7}$	10 s	40 s
10^{-7}	$10^{-7}/10^{-8}$	100 s	400 s
10^{-8}	$10^{-8}/10^{-9}$	1000 s	4000 s
10^{-9}	$10^{-9}/10^{-10}$	10 000 s	

Table 2-3/G.783 – Alternative interpretation of maximum detection and clearing time requirements in previous revision of this Recommendation

Detector threshold	Multiplex section VC-4 VC-3	VC-2 VC-12 VC-11
10^{-3}	10 ms	40 ms
10^{-4}	100 ms	400 ms
10^{-5}	1 s	4 s
10^{-6}	10 s	40 s
10^{-7}	100 s	400 s
10^{-8}	1000 s	4000 s
10^{-9}	10 000 s	

VC-3, VC-4: If *z* consecutive *VC-n* frames contain the value "1" in G1[5], a dRDI defect shall be detected. The dRDI defect shall be cleared if *z* consecutive *VC-n* frames contain the value "0" in G1[5]. *z* is 3, 5 or 10. *z* is not configurable.

VC-11, VC-12, VC-2: If *z* consecutive *VC-n* frames contain the value "1" in V5[8], a dRDI defect shall be detected. The dRDI defect shall be cleared if *z* consecutive *VC-n* frames contain the value "0" in V5[8]. *z* is 3, 5 or 10. *z* is not configurable.

The defect shall be cleared during an SSF condition.

2.2.2.7 Signal label processing: payload composition and payload mismatch defect (dPLM)

Basic function source direction

The generation of payload identifier in the signal label is required. The value is bound to and represents the selected (activated) adaptation function, as specified in Recommendation G.707.

Basic function sink direction

Byte C2/bits V5[5-7] signal label (TSL) is recovered from the AP.

The detection of dPLM is based on a comparison between the expected TSL, representing the selected/activated adaptation function, and the accepted TSL.

NOTE – Acceptance criteria and defect specification for the PLM is for further study to ensure integrity, and robustness to errors for PLM.

The value of the signal label passed to the management system should be an accepted value rather than the received value. The acceptance criteria are for further study.

The defect shall be cleared during a TSF condition.

The defect shall be suppressed (cleared) if the incoming TSL code is "1" (equipped non-specific).

2.2.2.8 Loss of Frame defect (dLOF)

STM-N signals: If the OOF state persists for [TBD] milliseconds, a Loss of Frame (LOF) state shall be declared. To provide for the case of intermittent OOFs, the integrating timer shall not be reset to zero until an in-frame condition persists continuously for [TBD] milliseconds. Once in a LOF state, this state shall be left when the in-frame state persists continuously for [TBD] milliseconds.

NOTE – Time intervals [TBD] are for further study. Values in the range 0 to 3 ms have been proposed.

2 Mbit/s signal: See Recommendation G.706.

2.2.2.9 HOVC Loss of Multiframe defect (dLOM)

If the multiframe alignment process (see 2.3.2) is in the OOM state and the H4 multiframe is not recovered within *X* ms, a dLOM defect shall be declared. Once in a dLOM state, this state shall be exited when the multiframe is recovered (multiframe alignment process enter the IM state). *X* shall be a value in the range 1 ms to 5 ms. *X* is not configurable.

2.2.2.10 Loss of Pointer defect (dLOP)

AU-n dLOP: See Annex C.

TU-m dLOP: See Annex C.

2.2.2.11 AIS defect (dAIS)

MS-n dAIS: See MS_{*n*}_TT_Sk.

AU-n dAIS: See Annex C.

TU-m dAIS: See Annex C.

1.5 Mbit/s and 2 Mbit/s G.704 signal: See Recommendation G.775.

2.2.2.12 TC Loss of Tandem Connection defect (dLTC)

VC-3, VC-4 TCM option 2: The function shall detect for the presence/absence of the tandem connection overhead in the byte N1/N2 by evaluating the multiframe alignment signal in bits 7 and 8 of byte N1. The Loss of Tandem Connection defect (dLTC) shall be detected if the multiframe alignment process is in the OOM state. The dLTC shall be cleared if the multiframe alignment process is in the IM state.

VC-11, VC-12, VC-2: The function shall detect for the presence/absence of the tandem connection overhead in the byte N1/N2 by evaluating the multiframe alignment signal in bits 7 and 8 of byte N2. The Loss of Tandem Connection defect (dLTC) shall be detected if the multiframe alignment process is in the OOM state. The dLTC shall be cleared if the multiframe alignment process is in the IM state.

2.2.2.13 TC unequipped defect (dUNEQ)

Byte N1/N2 is recovered from the CP.

VC-3, VC-4 TCM option 2: The unequipped tandem connection defect (dUNEQ) shall be detected if five consecutive VC-*n* (*n* = 3, 4) frames contain the "00000000" pattern in byte N1. The dUNEQ defect shall be cleared if in five consecutive VC-*n* frames any pattern other than the "00000000" is detected in byte N1.

VC-11, VC-12, VC-2: The unequipped tandem connection defect (dUNEQ) shall be detected if five consecutive VC-*n* (*n* = 11, 12, 2) frames contain the "00000000" pattern in byte N2. The dUNEQ defect shall be cleared if in five consecutive VC-*n* frames any pattern other than the "00000000" is detected in byte N2.

2.2.2.14 TC Trace Identifier Mismatch defect (dTIM)

Basic function Source direction

VC-3, VC-4 TCM option 2: The TTI information derived from the management reference point (MI_TxTI) is placed in the trace identifier bits in bits 7 and 8 of byte N1.

VC-11, VC-12, VC-2: The TTI information derived from the management reference point (MI_TxTI) is placed in the trace identifier bits in bits 7 and 8 of byte N2.

Basic function Sink direction

VC-3, VC-4 TCM option 2: The Trail Trace Identifier (TTI) in bits 7 and 8 of byte N1 is recovered from the CP.

VC-11, VC-12, VC-2: The Trail Trace Identifier (TTI) in bits 7 and 8 of byte N2 is recovered from the CP.

The detection of dTIM is based on a comparison between the expected TTI, configured via the management reference point (MI_ExTI), and the accepted TTI (AcTI). If dTIM detection is disabled via an input ("Set") command (MI_TIMdis) at the management reference point, then dTIM is considered "false".

NOTE 1 – Acceptance criteria and defect specification for the TTI is for further study to ensure integrity, and robustness to errors for TIM.

NOTE 2 – A mismatch in the CRC-7 or TFAS signal of the 16-byte trace identifier results in the detection of the dTIM defect.

The accepted TTI shall be reported via the management point (MI_AcTI) to the SEMF.

The Trace Identifier Mismatch defect (dTIM) shall be detected and cleared within a maximum period of 1 s in the absence of bit errors. The defect shall be cleared during the receipt of SSF.

SEMF interface

A TC TTI received by the SEMF via the V reference point is a 16- or 64-character string. The handling of a string shorter than 16 or 64 characters, respectively, is for further study.

If the expected TTI received by the SEMF is NULL, the TIM disable command at the management reference point is set to "true"; otherwise, the TIM disable command (MI_TIMdis) is set to "false" for the corresponding atomic function.

NOTE 3 – Expected TTI NULL is a special value (empty string). It is not a 16- or 64-byte string with "0" characters or binary "0000 0000".

2.2.2.15 TC Remote Defect Indication defect (dRDI)

VC-3, VC-4 TCM option 2: The function shall detect for a TC remote defect indication defect condition by monitoring the RDI signal. dRDI shall be detected if five consecutive N1 [8] [73] contain the value "1". dRDI shall be cleared if five consecutive N1[8][73] contain the value "0". The defect shall be cleared during an SSF condition.

VC-11, VC-12, VC-2: The function shall detect for a TC remote defect indication defect condition by monitoring the RDI signal. dRDI shall be detected if five consecutive N2[8][73] contain the value "1". dRDI shall be cleared if five consecutive N2[8][73] contain the value "0". The defect shall be cleared during an SSF condition.

2.2.2.16 TC Remote Outgoing VC defect (dODI)

VC-3, VC-4 TCM option 2: The TC remote outgoing VC defect (dODI) shall be detected if five consecutive bits N1[7][74] contain the value "1". dODI shall be cleared if five consecutive N1[7][74] contain the value "0". The defect shall be cleared during an SSF condition.

VC-11, VC-12, VC-2: The TC remote outgoing VC defect (dODI) shall be detected if five consecutive bits N2[7][74] contain the value "1". dODI shall be cleared if five consecutive N2[7][74] contain the value "0". The defect shall be cleared during an SSF condition.

2.2.2.17 TC Incoming AIS defect (dIncAIS)

VC-3, VC-4 TCM Option 2: The TC incoming AIS defect (dIncAIS) shall be detected if five consecutive frames contain the "1110" pattern in the IEC bits (N1[1-4]). dIncAIS shall be cleared if in five consecutive frames any pattern other than the "1110" is detected in the IEC bits.

NOTE – Bits 1 to 4 of byte N1 support two applications: conveying the incoming error information and conveying the incoming AIS information to the TC tail end. Codes 0000 to 1101, 1111 represent IncAIS is false, code 1110 represents IncAIS is true.

VC-11, VC-12, VC-2: The TC incoming AIS defect (dIncAIS) shall be detected if five consecutive frames contain the "1" in bit 4 of byte N2. dIncAIS shall be cleared if in five consecutive frames value "0" is detected in bit 4 of byte N2.

2.2.2.18 Transmit Fail (dTF)

See Recommendation G.958.

2.2.2.19 Transmit Degrade (dTd)

See Recommendation G.958.

2.2.3 Consequent actions

This subclause presents in generic terms the generation and control of the set of consequent actions. Specific details are presented in each atomic function.

After a defect³ is detected, one or more of the following consequent actions may be requested:

- all-ONEs (AIS) insertion;
- RDI insertion;
- REI insertion;
- ODI insertion;
- OEI insertion;
- unequipped signal insertion;

³ For the case of REI, it is after anomaly detection.

- generation of "Server Signal Fail (SSF)" signal;
- generation of "Trail Signal Fail (TSF)" signal;
- generation of "Trail Signal Degrade (TSD)" signal.

Figure 2-5 shows how the aAIS, aRDI and aREI consequent action request signals control the associated consequent actions: insertion of all-ONEs, insertion of RDI code and insertion of REI value. Figure 2-5 also shows the location of aSSF, aTSF and aTSD consequent action requests.

Certain detected near-end defects cause the insertion of the all-ONEs signal in trail termination sink functions. Detected defects cause the insertion of the all-ONEs signal in adaptation sink functions. The reception of a Server Signal Fail (SSF) indication causes the insertion of all-ONEs in the adaptation source.

In cases where the all-ONEs signal is inserted either in a trail termination sink or in the previous adaptation sink function, the RDI code is inserted in the associated trail termination source signal. That is, the RDI code is inserted on detected defects or the reception of an SSF indication in a trail termination sink function (aRDI).

Every frame, the number of detected EDC violations (aREI) in the trail termination sink function is inserted in the REI bits in the associated trail termination source signal.

A connection function inserts the unequipped VC signal at one of its outputs if that output is not connected to one of its inputs.

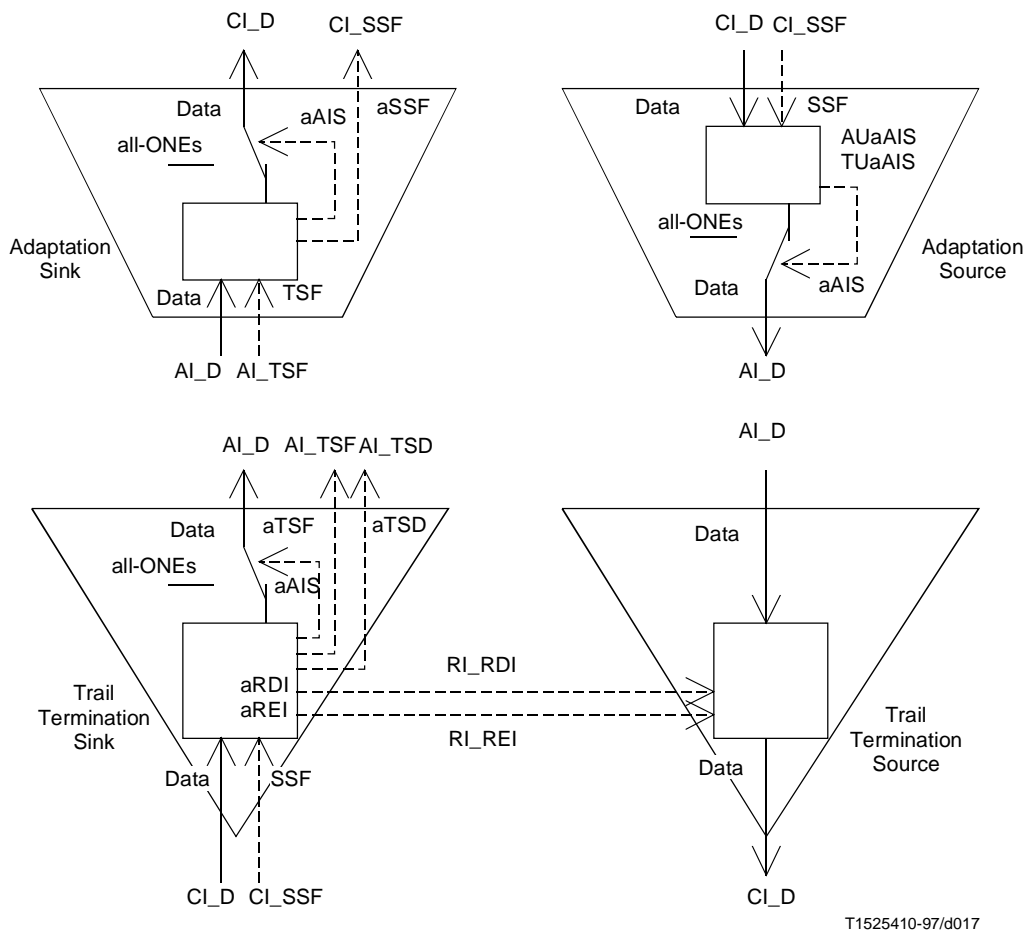

T1525410-97/d017

Figure 2-5/G.783 – Consequent action control: AIS, RDI and REI

2.2.3.1 Alarm Indication Signal (AIS)

The all-ONES (AIS) signal replaces the received signal under certain detected near-end defect conditions in order to prevent downstream failures being declared and alarms being raised. See Appendix IV for a description of the application and the insertion control.

Specific details with respect to all-ONES (AIS) insertion are defined in the individual atomic functions. Generically, the logic equations and the time requirement for the all-ONES (aAIS) insertion request are:

Adaptation sink functions: $aAIS \leftarrow dPLM \text{ or } dAIS/AI_TSF \text{ or } dLOA$

NOTE 1 – dLOA represents either dLOF, or dLOM or dLOP, whichever is applicable in the atomic function.

NOTE 2 – Certain adaptation sink functions do not detect dAIS. To ensure that the adaptation sink function is aware of the reception of the all-ONES signal, the termination sink function (which inserted the all-ONES signal on detected defect conditions) informs the adaptation sink about this condition by means of the AI_TSF signal. In such a case the dAIS term, in the aAIS expression, is replaced by AI_TSF.

NOTE 3 – In the case of 45 Mbit/s interface, the AIS signal is defined in Recommendation M.20.

Termination sink functions: $aAIS \leftarrow dAIS \text{ or } dUNEQ/dLOS \text{ or } dTIM$

NOTE 4 – The term dAIS is applicable for the MS_TT function. The term dLOS is applicable for physical section layer termination functions while dUNEQ represents a similar condition for the (SDH) path layers.

Adaptation source functions: $aAIS \leftarrow CI_SSF$

The termination sink, and adaptation sink and source functions shall insert the all-ONES (AIS) signal within 2 (multi)frames after AIS request generation (aAIS), and cease the insertion within 2 (multi)frames after the AIS request has cleared.

2.2.3.2 Remote Defect Indication (RDI)

If the all-ONES signal is inserted either in a trail termination sink or in the previous adaptation sink function, the RDI code is inserted in the associated trail termination source signal. See Appendix III for a description of the RDI application and the insertion control.

Specific details with respect to RDI insertion are defined in the individual atomic functions. Generically, the logic equations and the time requirement for the RDI insertion is:

Termination sink functions: $aRDI \leftarrow dAIS/CI_SSF \text{ or } dUNEQ \text{ or } dTIM$

Supervisory termination sink functions: $aRDI \leftarrow CI_SSF \text{ or } dTIM$

NOTE 1 – Some trail termination functions do not detect dAIS. To ensure that the trail termination function is aware of the reception of the all-ONES signal, the server layer (which inserted the all-ONES signal on detected defect conditions) informs the client layer about this condition by means of the CI_SSF signal. In such a case the dAIS term, in the aRDI expression, is replaced by CI_SSF.

NOTE 2 – For the case of supervisory-unequipped termination functions, dUNEQ cannot be used to activate aRDI; an expected supervisory-unequipped VC signal will have the signal label set to all-0s, causing a continuous detection of dUNEQ. If an unequipped VC signal is received, dTIM will be activated and can serve as a trigger for aRDI instead of dUNEQ.

Upon the declaration of aRDI the termination sink function shall activate RI_RDI (RI_RDI = true) within 2 (multi)frames, and deactivate RI_RDI (RI_RDI = false) within 2 (multi)frames after the RDI request has cleared.

The trail termination source function shall insert the RDI code within X (multi)frames after the RDI request generation (RI_RDI) in the trail termination sink function. It ceases RDI code insertion within X (multi)frames after the RDI request has cleared.

NOTE 3 – RDI is undefined and should be ignored by the receiver (TT_Sk) for the case of a unidirectional trail.

NOTE 4 – The value of X is for further study. X = 0 (immediate) is used in previous versions of this Recommendation.

2.2.3.3 Remote Error Indication (REI)

Every frame, the number of detected EDC violations in the trail termination sink function is inserted in the REI bits in the signal generated by the associated trail termination. See Appendix III for a description of the REI application and the insertion control.

Specific details with respect to REI insertion are defined in the individual atomic functions. Generically, the logic equations and the time requirement for the REI insertion is:

Termination sink function: $aREI \leftarrow \text{"number of error detection code violations"}$

Upon the declaration of aREI the termination sink function shall activate RI_REI (RI_REI = true) within 2 (multi)frames, and deactivate RI_REI (RI_REI = false) within 2 (multi)frames after the REI request has cleared.

The trail termination source function inserts the REI value in the next REI bit(s).

NOTE – REI is undefined and should be ignored by the receiver (TT_Sk) for the case of a unidirectional trail.

2.2.3.4 Server Signal Fail (SSF)

SSF signals are used to forward the defect condition of the server to the client in the next (sub)layer, to:

- prevent defect detection in layers without incoming AIS detectors in trail termination sink functions (e.g. S4_TT, S12_TT);
- report the server signal fail condition in layers without incoming AIS detectors in trail termination sink functions;
- control the link connection AIS (e.g. AU_AIS) insertion in adaptation source functions;
- initiate protection switching/restoration in the (protection-)connection function.

Specific details with respect to SSF generation are defined in the individual atomic functions. Generically, the logic equations and the time requirement for the SSF generation is:

Adaptation sink function: $aSSF \leftarrow dPLM \text{ or } dAIS/AI_TSF \text{ or } dLOA$

NOTE 1 – In case the adaptation function does not detect the AIS defect, the dAIS term will be replaced by AI_TSF generated by the previous TT_Sk.

NOTE 2 – The term dLOA is the general indication for dLOF, dLOM or dLOP, whichever is applicable.

Upon the declaration of aSSF the function shall activate CI_SSF (CI_SSF = true) within X (multi)frames, and deactivate CI_SSF (CI_SSF = false) within X (multi)frames after the SSF request has cleared.

NOTE 3 – The value of X is for further study. X = 0 (immediate) is used in previous versions of this Recommendation.

2.2.3.5 Trail Signal Fail (TSF)

TSF signals are used to forward the defect condition of the trail to the:

- adaptation sink function, to control all-ONEs (AIS) insertion in the function, when the function does not perform AIS defect detection; e.g. in S12/P12x_A_Sk.

Specific details with respect to TSF generation are defined in the individual atomic functions. Generically, the logic equations and the time requirement for the TSF generation is:

Termination sink function: $aTSF \leftarrow dAIS/CI_SSF \text{ or } dUNEQ/dLOS \text{ or } dTIM$

Supervisory termination sink function: $aTSF \leftarrow CI_SSF \text{ or } dTIM$

NOTE 1 – Some trail termination functions do not detect dAIS. To ensure that the trail termination function is aware of the reception of the all-ONEs signal, the server layer (which inserted the all-ONEs signal on detected defect conditions) informs the client layer about this condition by means of the aSSF signal. In such a case the dAIS term, in the aTSF expression, is replaced by aSSF.

NOTE 2 – For the case of supervisory-unequipped termination functions, dUNEQ cannot be used to activate; an expected supervisory-unequipped VC signal will have the signal label set to all-0s, causing a continuous detection of dUNEQ. If an unequipped VC signal is received, dTIM will be activated and can serve as a trigger for aTSF instead of dUNEQ.

Upon the declaration of aTSF the function shall activate AI_TSF (AI_TSF = true) within X (multi)frames, and deactivate AI_TSF (AI_TSF = false) within X (multi)frames after the TSF request has cleared.

NOTE 3 – The value of X is for further study. X = 0 (immediate) is used in previous versions of this Recommendation.

2.2.3.6 Trail Signal Fail protection (TSFprot)

TSFprot signals are used to forward the defect condition of the trail to the:

- protection-connection function in the trail protection sublayer, to initiate trail protection switching in that function;
- connection function in the same layer which performs a non-intrusively monitored SNC (SNC/N) protection scheme, to initiate SNC protection switching in that function.

Specific details with respect to TSFprot generation are defined in the individual atomic functions. Generically, the logic equations and the time requirement for the TSF generation is:

Termination sink function: $aTSFprot \leftarrow aTSF \text{ or } dEXC$

NOTE 1 – aTSFprot and aTSF will be identical for network elements that support error defects assuming bursty distribution of errors. For such networks, dEXC is assumed to be permanently false (see 2.2.2.5.2).

Upon the declaration of aTSFprot the function shall activate AI_TSFprot (AI_TSFprot = true) within X (multi)frames, and deactivate AI_TSFprot (AI_TSFprot = false) within X (multi)frames after the TSFprot request has cleared.

NOTE 2 – The value of X is for further study. X = 0 (immediate) is used in previous versions of this Recommendation.

2.2.3.7 Trail Signal Degrade (TSD)

TSD signals are used to forward the signal degrade defect condition of the trail to the:

- protection-connection function in the trail protection sublayer, to initiate trail protection switching in that function;
- connection function in the layer to initiate subnetwork connection protection switching in that function for the case of a non-intrusive monitored SNC (SNC/N) protection scheme.

Specific details with respect to TSD generation are defined in the individual atomic functions. Generically, the logic equations and the time requirement for the TSD generation is:

Termination sink function: $aTSD \leftarrow dDEG$

Upon the declaration of aTSD the function shall activate AI_TSD (AI_TSD = true) within X (multi)frames, and deactivate AI_TSD (AI_TSD = false) within X (multi)frames after the TSD request has cleared.

NOTE – The value of X is for further study. X = 0 (immediate) is used in previous versions of this Recommendation.

2.2.3.8 Outgoing Defect Indication (ODI)

Specific details with respect to ODI insertion are defined in the individual atomic functions. Generically, the logic equations and the time requirement for the ODI insertion is:

Termination sink functions: $aODI \leftarrow CI_SSF \text{ or } dUNEQ \text{ or } dTIM \text{ or } dIncAIS \text{ or } dLTC$

Upon the declaration of aODI the termination sink function shall activate RI_ODI (RI_ODI = true) within 2 multiframes, and deactivate RI_ODI (RI_ODI = false) within 2 multiframes after the ODI request has cleared.

The function shall insert the ODI code within X multiframes (9.5 ms/38 ms) after the ODI request generation (RI_ODI) in the tandem connection trail termination sink function. It ceases ODI code insertion at the first opportunity after the ODI request has cleared.

NOTE 1 – ODI is undefined and should be ignored by the receiver (TT_Sk) for the case of a unidirectional TC trail.

NOTE 2 – The value of X is for further study.

2.2.3.9 Outgoing Error Indication (OEI)

Every frame, the number of detected EDC violations in the VC signal in the TC trail termination sink function is inserted in the OEI bit in the signal generated by the associated TC trail termination.

Specific details with respect to OEI insertion are defined in the individual atomic functions. Generically, the logic equations and the time requirement for the OEI insertion is:

TC Termination sink function: $aOEI \leftarrow$ "number of error detection code violations in the VC"

Upon the declaration of aOEI the termination sink function shall activate RI_OEI (RI_OEI = true) within 2 (multi)frames, and deactivate RI_OEI (RI_OEI = false) within 2 (multi)frames after the OEI request has cleared.

The trail termination source function inserts the OEI value in the next OEI bit.

NOTE – OEI is undefined and should be ignored by the receiver (TT_Sk) for the case of a unidirectional TC trail.

2.2.3.10 Unequipped Virtual Container (VC) signal

Unequipped indicating signals are generated by (virtual) connection functions.

If the output of a VC connection function is not connected to an input of that VC connection function, the VC originates at that connection function. In this case an unequipped VC shall be generated by the connection function.

NOTE – In cases where a VC originates at a "terminal multiplexer" or "line system" network element which has only a limited number of tributary port units (containing the path termination functions) installed, the STM-N aggregate signal could contain undefined VCs. To prevent such conditions, which cause failures and alarms, an unequipped VC or supervisory-unequipped VC should be inserted in the unoccupied VC time slots.

2.2.4 Defect correlations

This subclause presents in generic terms the defect correlations within trail termination, adaptation and connection functions. Specific details are presented in each atomic function. See 1.10 for a description of the applied specification technique.

Since all of the defects will appear at the input of the defect correlation filter (Figures 2-1 and 2-2), it provides correlation to reduce the amount of information offered to the SEMF. Table 2-1 lists the transmission fault cause indications that will be provided by the atomic functions.

A fault may cause multiple defect detectors to be activated. To determine, from the activated defects, which fault is present, the activated defects are correlated to obtain the fault cause.

The cZZZ fault causes (correlated defects) shall be activated if the expression is true. cZZZ shall be deactivated if the expression is false.

2.2.4.1 Termination sink functions

Trail termination sink: $cUNEQ \leftarrow$ dUNEQ and MON

Supervisory trail termination sink: $cUNEQ \leftarrow$ dUNEQ and dTIM and (AcTI = all "0"s) and MON

Trail termination sink: $cTIM \leftarrow$ dTIM and (not dUNEQ) and MON

Supervisory trail termination sink: $cTIM \leftarrow$ dTIM and not (dUNEQ and AcTI = all "0"s) and MON

cDEG	← dDEG and (not dTIM) and MON
cRDI	← dRDI and (not dUNEQ) and (not dTIM) and RDI_Reported and MON
cSSF	← aSSF/dAIS and MON
cLOS	← dLOS and MON
cAIS	← dAIS and AIS_Reported and MON

The reporting of the following defects is an option: AIS, RDI, ODI. These defects are "secondary defects" in that they are the result of a consequent action on a "primary defect" in another network element.

Example: A single STM-16 LOS defect (dLOS) may cause a few thousand AIS defects (e.g. AU4dAISs, TU12dAISs) to be detected in the network and about one thousand RDI defects (e.g. MS16dRDI, VC4dRDIs, VC12dRDIs).

It shall therefore be an option to report AIS, RDI, or ODI as a fault cause. This is controlled by means of the parameters AIS_Reported, RDI_Reported, and ODI_Reported, respectively. The default for these parameters is "false".

NOTE 1 – dUNEQ, dTIM, dDEG and dRDI are cleared during an SSF/TSF condition.

NOTE 2 – In the MS_TT function, defects of the server layer are detected by dAIS from the K2 byte and not through SSF.

NOTE 3 – By default, AIS as such is not reported. Instead trail terminations shall report (as an option) that the server (layer) failed to pass the signal (Server Signal Fail) if they receive the all-ONEs (AIS) signal. This reduces the declaration of "AIS failures" to one failure (fSSF) at the Trail Termination NE. No failures are generated at intermediate nodes in the (long) trail.

NOTE 4 – Refer to 2.2.1 for a MON description.

NOTE 5 – The detection of an unequipped VC signal is possible in a termination supervisory sink function despite both the supervisory-unequipped VC signal and the unequipped VC signal having signal label code "0". A trace identifier mismatch will be detected with the accepted trace identifier being all-ZEROs. This combination is the signature of the reception of an unequipped VC.

2.2.4.2 Adaptation sink function

cPLM	← dPLM and (not aTSF)
cAIS	← dAIS and (not aTSF) and (not dPLM) and AIS_Reported
cLOA	← dLOA and (not dAIS) and (not dPLM)

It shall be an option to report AIS as a fault cause. This is controlled by means of the parameter AIS_Reported. The default shall be AIS_Reported = false.

NOTE 1 – dLOA represents dLOF, dLOP or dLOM, whichever is applicable.

NOTE 2 – The specification of the Pointer Interpreter algorithm is such that either dAIS or dLOP can be declared, not both at the same time. Refer to Annex C.

2.2.4.3 Connection function

cFOP	← dFOP and (not CI_SSF)
------	-------------------------

2.2.5 One second window for performance monitoring

The one second filters perform a simple integration of reported anomalies and defects by counting during a one-second interval. At the end of each one-second interval the contents of the counters is made available to the performance monitoring processes within the SEMF for further processing (see clause 5/G.784). Generically the following (superset of) counter outputs will be provided:

- near-end/far-end/outgoing errored block counts (e.g. HO path, LO path), or BIP violation counts (e.g. MS section);
- near-end/far-end/outgoing defect seconds;
- pointer justification counts;
- protection switch counts and protection switch seconds;
- out-of-frame seconds.

This subclause presents in generic terms the performance monitoring primitive generation within atomic functions. Specific details are presented in each atomic function.

2.2.5.1 Near-end Errored Block Count (pN_EBC)

VC-11, VC-12, VC-2, VC-3, VC-4: Every second, the number of errored near-end blocks (N_Bs) within that second is counted as the Near-end Error Block Count (pN_EBC).

A "Near-end Block" (N_B) is errored if one or more EDC violations are detected.

For backward compatibility the specification is as follows: Every second, the number of EDCVs is counted and "translated" into the pN_EBC according to Annex C/G.826.

MS1, MS4, MS16: Every second, the number of BIP violations within that second is counted as the Near-end Error Block Count (pN_EBC).

RS1: Every second, the number of errored near-end blocks within that second is counted as the Near-end Errored Block Count (pN_EBC).

A "Near-end Block"(N_B) is errored (nN_B) if one or more EDC violations are detected.

RS4, RS16: The definition of pN_EBC is for further study.

2.2.5.2 Near-end Defect Second (pN_DS)

Every second with at least one occurrence of aTSF (e.g. CI_SSF, dAIS, dTIM, dUNEQ) or dEQ shall be indicated as a Near-end Defect Second (pN_DS).

$pN_DS \leftarrow aTSF \text{ or } dEQ$

2.2.5.3 Far-end Errored Block Count (pF_EBC)

VC-11, VC-12, VC-2, VC-3, VC-4: Every second, the number of errored far-end blocks (F_Bs) within that second is counted as the Far-end Error Block Count (pF_EBC).

A "Far-end Block" (F_B) is errored if the REI count indicates one or more errors.

For backward compatibility the specification is as follows: Every second, the number of errors conveyed back via REI is counted and "translated" into the pF_EBC according to Annex C/G.826.

MS1, MS4, MS16: Every second, the number of BIP violations conveyed via REI within that second is counted as the Far-end Error Block Count (pF_EBC).

2.2.5.4 Far-end Defect Second (pF_DS)

Every second with at least one occurrence of dRDI shall be indicated as a Far-end Defect Second (pF_DS).

$pF_DS \leftarrow dRDI$

2.2.5.5 Out-of-Frame Seconds (pOFS)

An Out-of-Frame Second (pOFS) is a second in which the frame alignment process was in the OOF state for the full or a part of that second.

2.2.5.6 Protection Switch Count (pPSC)

The definition of Protection Switch Count (pPSC) is for further study.

2.2.5.7 Protection Switch Second (pPSSw, pPSSp)

The definition of Protection Switch Second (pPSSw, pPSSp) is for further study.

2.2.5.8 Pointer Justification Counts (pPJC+, pPJC-)

A positive Pointer Justification Count (pPJC+) is a count of the number of Generated Pointer Increments in a one-second period.

A negative Pointer Justification Count (pPJC-) is a count of the number of Generated Pointer Decrements in a one-second period.

NOTE – pPJC is the input for the 15-minute and 24-hour PJE (Pointer Justification Event) counts.

2.3 Generic processes

2.3.1 STM-N frame alignment

The frame alignment shall be found by searching for the A1, A2 bytes contained in the STM-N signal. The framing pattern searched for may be a subset of the A1 and A2 bytes contained in the STM-N signal. The frame signal shall be continuously checked with the presumed frame start position for the alignment. If in the In Frame state (IF), the maximum Out of Frame (OOF) detection time shall be 625 μ s for a random unframed signal, the algorithm used to check the alignment shall be such that, under normal conditions, a 10^{-3} (Poisson type) error ratio will not cause a false OOF more than once per 6 minutes. If in the OOF state, the maximum frame alignment time shall be 250 μ s for an error-free signal with no emulated framing patterns, the algorithm used to recover from the OOF state shall be such that, the probability for false frame recovery with a random unframed signal shall be no more than 10^{-5} per 250 μ s time interval.

2.3.2 Lower order VC-1, VC-2 multiframe alignment

If the TUG structure contains TUG-2s, the 500 μ s (multi)frame start phase shall be recovered performing multiframe alignment on bits 7 and 8 of byte H4. Out of Multiframe (OOM) shall be assumed once when an error is detected in the H4 bits 7 and 8 sequence. Multiframe alignment shall be assumed to be recovered, and the In Multiframe (IM) state shall be entered, when in four consecutive VC-*n* frames an error free H4 sequence is found.

2.3.3 STM-N scrambling and descrambling

Scrambling is performed according to Recommendation G.707, which excludes the first row of the STM-N RSOH ($9 \times N$ bytes, including the A1, A2, J0 and bytes reserved for national use or future international standardization) from scrambling.

Descrambling is performed according to Recommendation G.707, which excludes the first row of the STM-N RSOH ($9 \times N$ bytes, including the A1, A2, J0 and bytes reserved for national use or future international standardization) from descrambling.

2.3.4 Tandem connection multiframe alignment

VC-3, VC-4: Multiframe alignment shall be performed on bits 7 and 8 of byte N1 to recover the TTI, RDI, and ODI signals transported within the multiframed bits. The multiframe alignment shall be found by searching for the pattern "1111 1111 1111 1110" within the bits 7 and 8 of byte N1. The signal shall be continuously checked with the presumed multiframe start position for the alignment.

NOTE – The frame alignment process described above for the VC-4 and VC-3 is only applicable for TCM option 2.

VC-11, VC-12, VC-2: Multiframe alignment shall be performed on bits 7 and 8 of byte N2 to recover the TTI, RDI, and ODI signals transported within the multiframed bits. The multiframe alignment shall be found by searching for the pattern "1111 1111 1111 1110" within the bits 7 and 8 of byte N2. The signal shall be continuously checked with the presumed multiframe start position for the alignment.

Frame alignment is deemed to have been lost [entering Out of Multiframe (OOM) state] when two consecutive FAS are detected in error (i.e. 1 error in each FAS).

Frame alignment is deemed to have been recovered [entering In Multiframe (IM) state] when one non-errored FAS is found.

2.3.5 Tandem connection BIP compensation

VC-3, VC-4: The VC-3/4 BIP-8 (byte B3) shall be compensated for the addition/removal of tandem connection overhead according to the rule found in D.4/G.707 and illustrated in Figure 2-6.

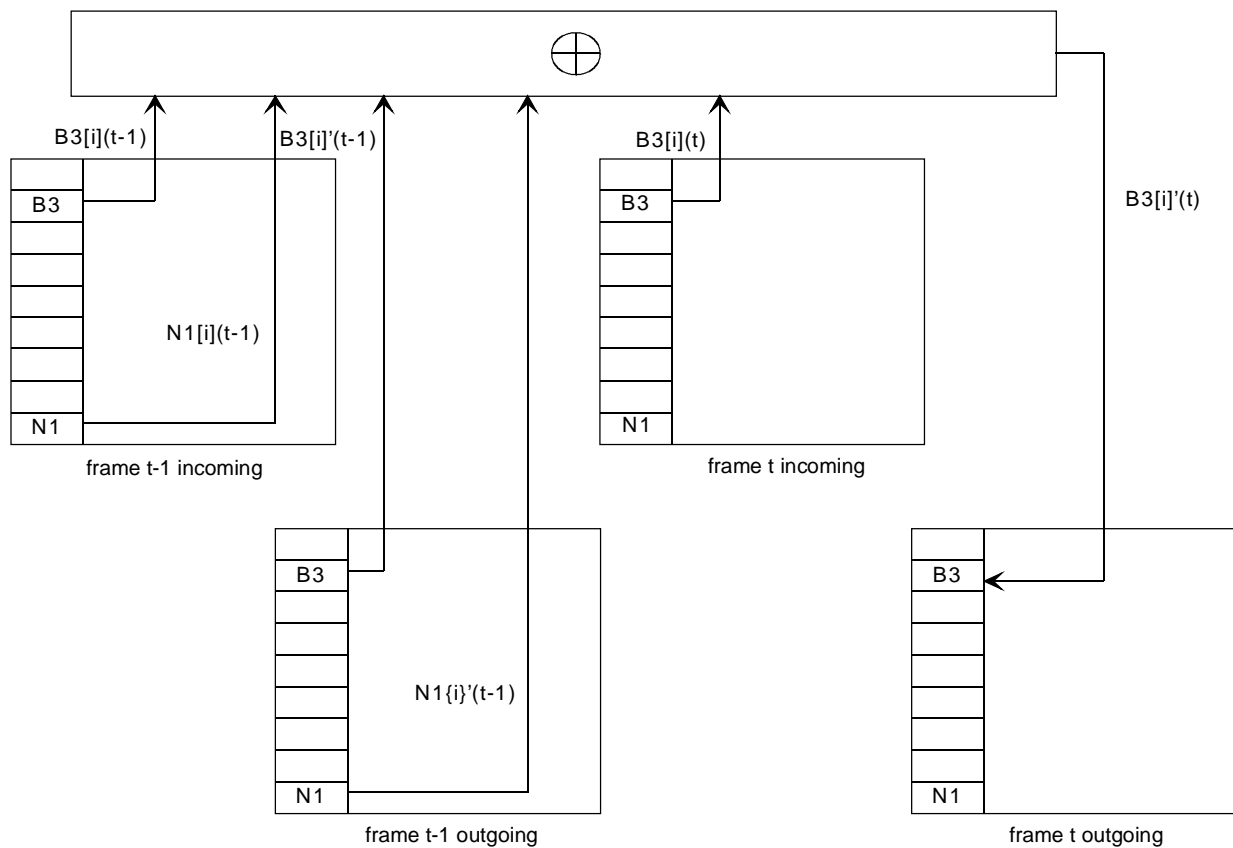

T1525420-97/d018

Figure 2-6/G.783 – B3[i], i = 1...8 compensating process

VC-11, VC-12, VC-2: The VC-1/2 BIP-2 (in bits 1 and 2 of byte V5) shall be compensated for the addition/removal of tandem connection overhead according to the rule found in E.4/G.707 and illustrated in Figure 2-7.

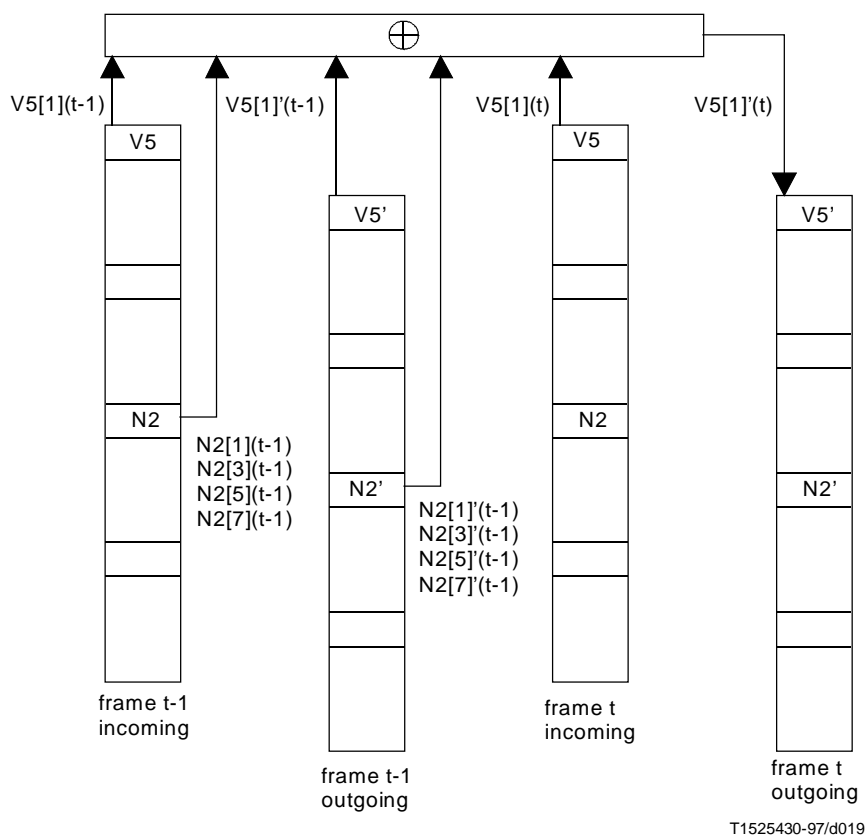

Figure 2-7/G.783 – V5[1-2] compensating process

VC-11, VC-12, VC-2: Even BIP-2 is computed for each bit pair of every byte of the preceding VC-1/2 including V5 and compared with bit N2 and 2 of V5 recovered from the current frame. A difference between the computed and recovered BIP-2 values is taken as evidence of one or more errors (ON_B) in the computation block. See Figure 2-9.

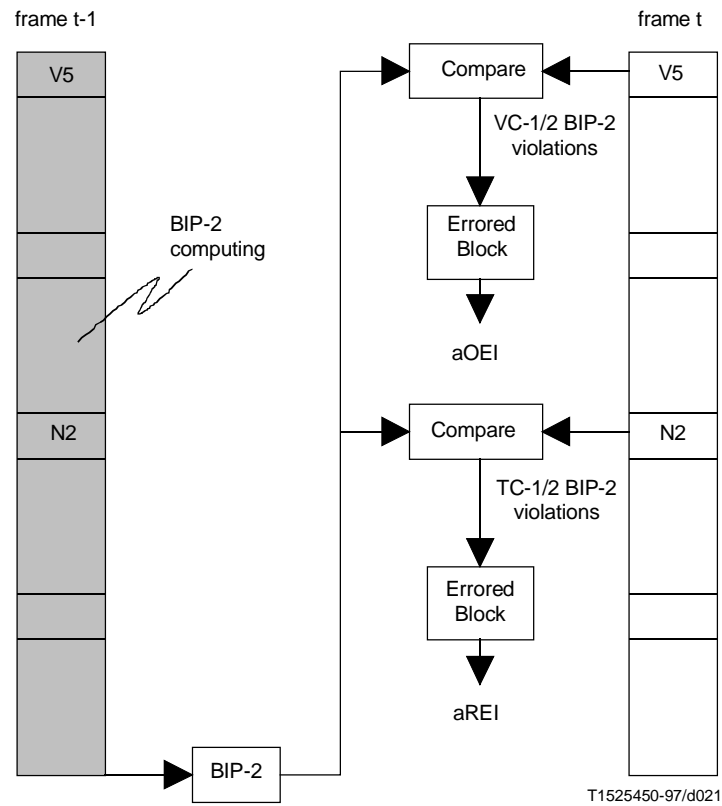

Figure 2-9/G.783 – TC-1/2 and VC-1/2 BIP-2 computing and comparison

2.3.7 VC-3/4 tandem connection incoming error code determination

Even BIP-8 shall be computed for each bit n of every byte of the preceding VC- n ($n = 3, 4$) including B3 and compared with byte B3 recovered from the current frame. A difference between the computed and recovered BIP-8 values shall be taken as evidence of one or more errors in the computation block, and shall be inserted in bits 1 to 4 of byte N1 (Figure 2-10, Table D.2/G.707). If SF condition is present, code "1110" for option 2 TCM and code "1111" for option 1 TCM shall be inserted in bits 1 to 4 of byte N1 instead of the number of incoming BIP-8 violations.

NOTE – Zero BIP-8 violations detected in the tandem connection incoming signal must be coded with a non-all-ZEROS IEC code. This allows this IEC field to be used at the TC trail end as differentiator between TC incoming unequipped VC and unequipped TC.

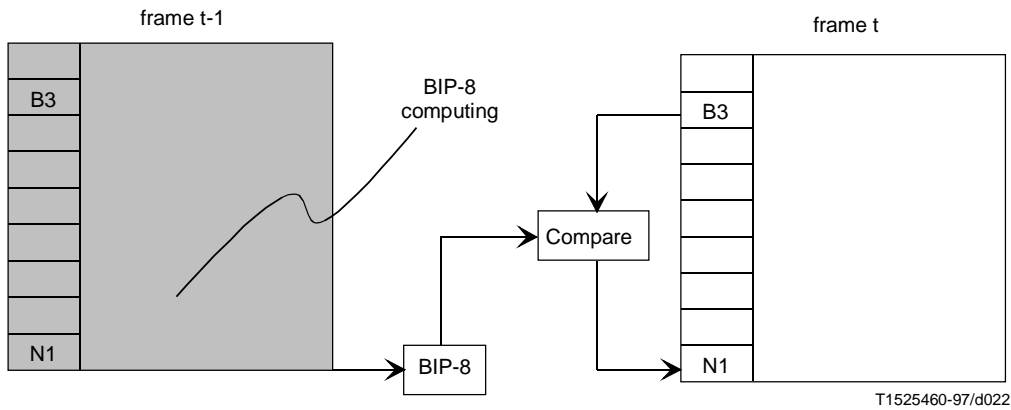

Figure 2-10/G.783 – HTC-IEC computing and insertion

3 SDH physical layer

The atomic functions defining the SDH physical interface layer are described below. They describe the physical and logical characteristics of the optical and electrical interfaces used within SDH equipment at the ES1_CP or OS n _CP (where $n = 1, 4, 16, 64$) as specified in Recommendations G.703, G.707, G.957. See Figures 3-1 and 3-2.

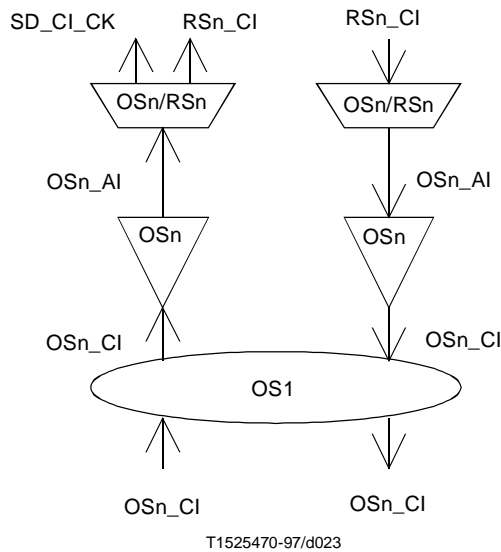

Figure 3-1/G.783 – STM-N optical section atomic functions

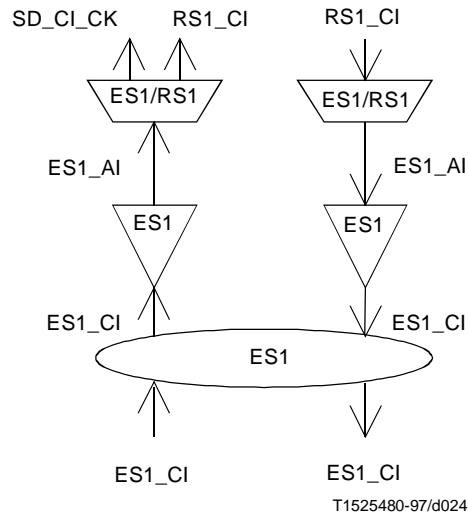

Figure 3-2/G.783 – STM-1 electrical section atomic functions

STM-N electrical/optical section layer CP

Characteristic information OS_n_CI $ES1_CI$ of the layer CP is a digital, optical or electrical (coded) signal of defined power, bit rate, pulse width and wavelength. A range of such characteristic signals are defined.

The optical interface signals are specified in Recommendation G.957. The electrical interface signals are specified in Recommendation G.703.

Relationship to previous versions of Recommendation G.783

The 1994 version of Recommendation G.783 refers to the SPI basic function. Table 3-1 shows the relationship between the basic functions and the atomic functions in the SDH Physical Layer.

Table 3-1/G.783 – SDH Physical Layer basic and atomic functions

Basic function	Atomic function
SPI	OS_n_TT $ES1_TT$ OS_n/RS_n_A $ES1/RS1_A$

3.1 Connection

Not applicable. There are no connection functions defined for this layer.

3.2 Termination: OSn_TT and ESn_TT

3.2.1 STM-N optical section trail termination source (OSn_TT_So)

Symbol

See Figure 3-3.

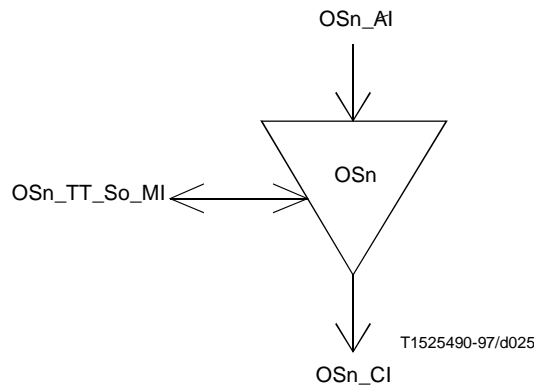

Figure 3-3/G.783 – OSn_TT_So symbol

Interfaces

See Table 3-2.

Table 3-2/G.783 – OSn_TT_So input and output signals

Input(s)	Output(s)
OSn_AI_Data	OSn_CI_Data OSn_TT_So_MI_cTD OSn_TT_So_MI_cTF

Processes

Data at the RSn_CP is fully formatted STM-N data as specified in Recommendation G.707. Data is presented together with associated timing at the RSn_CP by the RSn_TT_So function. The termination function conditions the data for transmission over the optical medium and presents it at the OSn_CP.

Defects

Parameters relating to the physical status of the interface such as transmit fail or transmit degraded shall be reported at the OSn_TT_So_MP. For optical systems, these defect parameters are specified in 2.2.

Consequent actions

None.

Defect correlations

cTD ← dTD and (not dTF)

cTF ← dTF

Performance monitoring

None.

3.2.2 STM-N optical section trail termination sink OSn_TT_Sk

Symbol

See Figure 3-4.

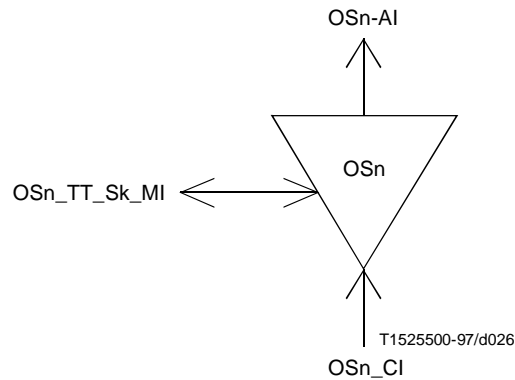

Figure 3-4/G.783 – OSn_TT_Sk symbol

Interfaces

See Table 3-3.

Table 3-3/G.783 – OSn_TT_Sk input and output signals

Input(s)	Output(s)
OSn_CI_Data	OSn_AI_Data
OSn_TT_Sk_MP_PortMode	OSn_AI_TSF
	OSn_TT_Sk_MI_cLOS

Processes

The STM-N signal at the OSn_CP is a similarly formatted and conditioned signal (as described in XXX) which is degraded within specific limits by transmission over the physical medium.

The operation of Port mode is described in 2.2.1.

Defects

dLOS: See 2.2.

Consequent actions

aTSF ← dLOS

Defect correlations

cLOS ← dLOS and MON

Performance monitoring

None.

3.2.3 STM-1 electrical section trail termination source ES1_TT_So

Symbol

See Figure 3-5.

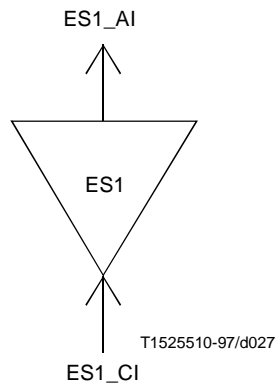

Figure 3-5/G.783 – ES1_TT_So symbol

Interfaces

See Table 3-4.

Table 3-4/G.783 – ES1_TT_So input and output signals

Input(s)	Output(s)
ES1_AI_Data	ES1_CI_Data

Processes

Data at the ES1_AP is fully formatted STM-1 data stream as specified in Recommendation G.707. Data is presented together with associated timing at the ES1_CP by the ES1_RS1_A function. The termination function conditions the data for transmission over electrical medium and presents it at the ES1_CP.

Defects

None.

Consequent actions

None.

Defect correlations

None.

Performance monitoring

None.

3.2.4 STM-1 electrical section trail termination sink ES1_TT_Sk

Symbol

See Figure 3-6.

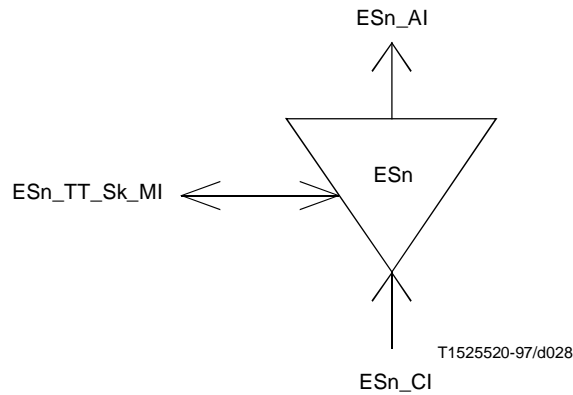

Figure 3-6/G.783 – ES1_TT_Sk symbol

Interfaces

See Table 3-5.

Table 3-5/G.783 – ES1_TT_Sk input and output signals

Input(s)	Output(s)
ES1_CI_Data ES1_TT_Sk_MI_PortMode	ES1_AI_Data ES1_AI_TSF ES1_TT_Sk_MI_cLOS

Processes

The STM-1 signal at the ES1_CP is a similarly formatted and conditioned signal (as described in Recommendation G.703) which is degraded within specific limits by transmission over the physical medium.

The operation of Port mode is described in 2.2.1.

Defects

dLOS: See 2.2.

Consequent actions

The function shall perform the following consequent actions:

aTSF ← dLOS

Defect correlations

The function shall perform the following defect correlations to determine the most probable fault cause. This fault cause shall be reported to the SEMF.

cLOS ← dLOS and MON

Performance monitoring

None.

3.3 Adaptation

3.3.1 OSn/RSn_A

3.3.1.1 Optical section to regenerator section adaptation source OSn/RSn_A_So

Symbol

See Figure 3-7.

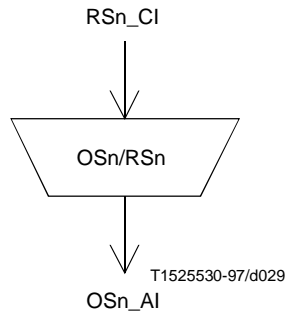

Figure 3-7/G.783 – OSn/RSn_A_So symbol

Interfaces

See Table 3-6.

Table 3-6/G.783 – OSn/RSn_A_So input and output signals

Input(s)	Output(s)
RSn_CI_Data RSn_CI_Clock	OSn_AI_Data

Processes

Defects

None.

Consequent actions

None.

Defect correlations

None.

Performance monitoring

None.

3.3.1.2 Optical section to regenerator section adaptation sink OSn/RSn_A_Sk

Symbol

See Figure 3-8.

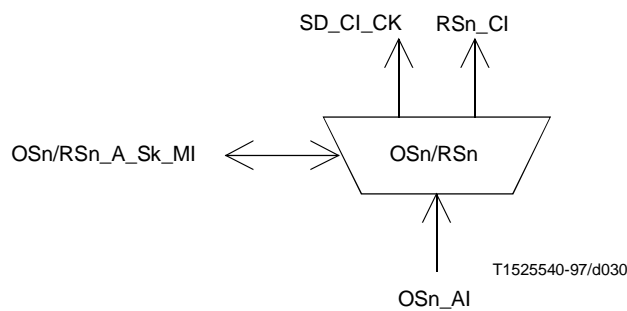

Figure 3-8/G.783 – OSn/RSn_A_Sk symbol

Interfaces

See Table 3-7.

Table 3-7/G.783 – OSn/RSn_A_Sk input and output signals

Input(s)	Output(s)
OSn_AI_Data OSn_AI_TSF	RSn_CI_Data RSn_CI_Clock RSn_CI_FS RSn_CI_SSF OSn/RSn_A_Sk_MI_cLOF OSn/RSn_A_Sk_MI_pOFS

Processes

Fully formatted and regenerated STM-N data and associated timing is received by the RSn_CP from the OSn_TT_Sk function. The OSn/RSn function regenerates this signal to form data and associated timing at the RSn_CP. The recovered timing is also made available at reference point T1 to the synchronous equipment timing source for the purpose of synchronizing the synchronous equipment reference clock. The function also recovers frame alignment and identifies the frame start positions in the data of the MSn_CP. The STM-N signal is then descrambled (except for the first row of the RSOH) and then the RSOH bytes are recovered before presenting the framed STM-N data and timing at the MSn_CP.

The frame alignment process is described in 2.3.1.

Defects

dLOF: See 2.2.

Consequent actions

The function shall perform the following consequent actions:

aAIS ← dLOF or AI_TSF

aSSF ← dLOF or AI_TSF

Defect correlations

The function shall perform the following defect correlations to determine the most probable fault cause. This fault cause shall be reported to the SEMF.

cLOF ← dLOF and (not dLOS)

Performance monitoring

The function shall perform the following performance monitoring primitives processing.

Any second with at least one OOF event shall be reported as a pOFS optional in Recommendation G.784.

3.3.2 ES1/RS1_A

3.3.2.1 STM-1 electrical section to regenerator section adaptation source ES1/RS1_A_So

Symbol

See Figure 3-9.

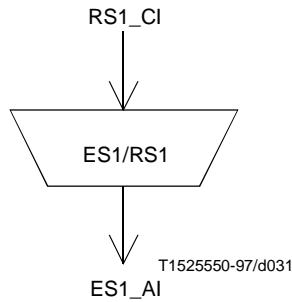

Figure 3-9/G.783 – ES1/RS1_A_So symbol

Interfaces

See Table 3-8.

Table 3-8/G.783 – ES1/RS1_A_So input and output signals

Input(s)	Output(s)
RS1_CI_Data RS1_CI_Clock	ES1_AI_Data

Processes

This function provides CMI encoding for STM-1 signals.

Defects

None.

Consequent actions

None.

Defect correlations

None.

Performance monitoring

None.

3.3.2.2 STM-1 electrical section to regenerator section adaptation sink (ES1/RS1_A_Sk)

Symbol

See Figure 3-10.

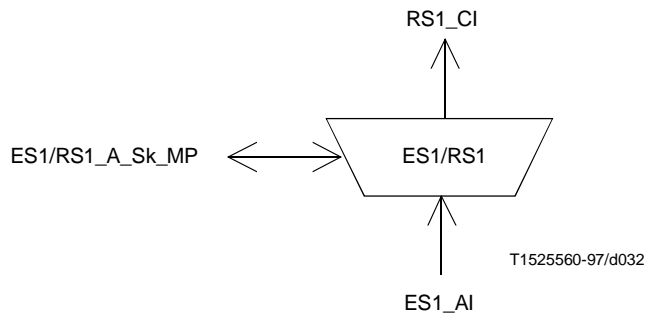

Figure 3-10/G.783 – ES1/RS1_A_Sk symbol

Interfaces

See Table 3-9.

Table 3-9/G.783 – ES1/RS1_A_Sk input and output signals

Input(s)	Output(s)
ES _n _AI_Data ES _n _AI_TSF	RS _n _CI_Data RS _n _CI_Clock RS _n _CI_FS RS _n _CI_SSF ES _n /RS _n _A_Sk_MI_cLOF ES _n /RS _n _A_Sk_MI_pOFS

Processes

This function provides CMI decoding for STM-1 signals (n = 1). It also regenerates this signal to form data and associated timing at the RS_n_CP. The recovered timing is also made available at reference point T1 to the synchronous equipment timing source for the purpose of synchronizing the synchronous equipment reference clock if selected.

Fully formatted and regenerated STM-N data and associated timing is received by the RS_n_CP from the ES1_TT_Sk function. The RST function recovers frame alignment and identifies the frame start positions in the data at the MS_n_CP.

The STM-N frame alignment process is described in 2.3.1.

Defects

dLOF: See 2.2.

Consequent actions

The function shall perform the following consequent actions:

aAIS ← dLOF

aSSF ← dLOF

If Loss of Frame (LOF) is detected, then a logical all-ones (AIS) signal shall be applied at the data signal output within 2 frames (250 μs). Upon termination of the above defect conditions, the logical all-ones signal shall be removed within 2 frames (250 μs).

Defect correlations

The function shall perform the following defect correlations to determine the most probable fault cause. This fault cause shall be reported to the SEMF.

cLOF ← dLOF and (not AI_TSF)

Performance monitoring

Any second with at least one OOF event shall be reported as a pOFS (optional in the Recommendation G.784).

3.4 Sublayer functions (N/A)

There are no sublayer functions applicable to this subclause.

4 Regenerator section layer

The data at the regenerator section layer CP (RS CI) is octet structured with codirectional timing and 125 microsecond frame length. The format is shown in Figures 4-1 and 4-2.

The RS CI consists of the A1, A2 framing bytes, the J0 RS trace byte, the B1 BIP-8 byte, the E1 order-wire byte, the F1 RS user byte, the D1-D3 RS DCC bytes and the NU bytes, together with the MS CI as defined in Recommendation G.707.

1 1 to n	2 1 to n	3 1 to n	4 1 to n	5 1 to n	6 1 to n	7 1 to n	8 1 to n	9 1 to n	(value of b coordinate) (value of c coordinate)
A1	A1	A1	A2	A2	A2	JO	NU	NU	
B1			E1			F1	NU	NU	
D1			D2			D3			

T1525570-97/d033

Figure 4-1/G.783 – Regenerator section CI data format in S(b,c) format

							NU	NU	
			E1			F1	NU	NU	
D1			D2			D3			

T1525580-97/d034

NOTE to Figures 4-1 and 4-2 – The D1-D3, J0, B1, E1 and F1 bytes are only present in columns S(a,b,1).

Figure 4-2/G.783 – Regenerator section AI data format in S(b,c) format

NOTE – This Recommendation is intended for the general case of an interstation interface. A reduced functionality requirement for an intrastation interface is for further study.

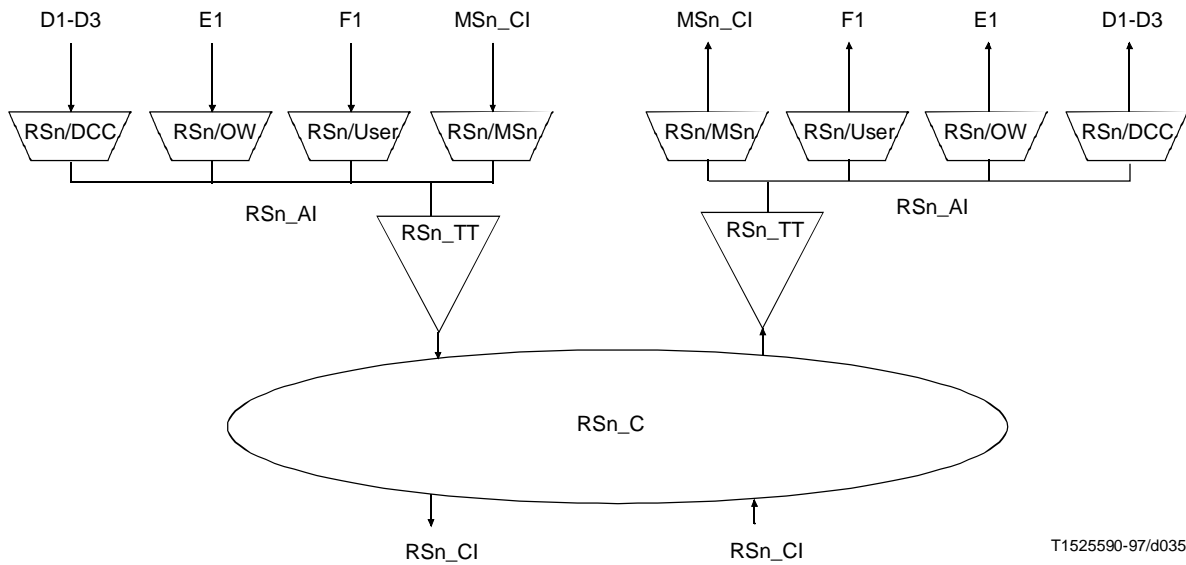

Figure 4-3/G.783 – Regenerator section functions

Relationship to previous versions of Recommendation G.783

The 1994 version of Recommendation G.783 refers to the RST basic function. Table 4-1 shows the relationship between the basic functions and the atomic functions in the regenerator section layer.

Table 4-1/G.783 – Regenerator section layer basic and atomic functions

Basic function	Atomic function
RST	<i>RSn_TT</i> <i>RSn/DCC_A</i> <i>RSn/OW_A</i> <i>RSn/Aux_A</i> <i>RSn/MSn_A</i>

4.1 Connection (Not/Applicable)

4.2 Termination: *RSn_TT*

The *RSn_TT* function acts as a source and sinks for the Regenerator Section OverHead (RSOH). A regenerator section is a maintenance entity between and including two *RSn_TT* functions. The information flows associated with the *RSn_TT* function are described with reference to Figures 4-4, 4-5, 4-6 and Tables 4-2 and 4-3.

NOTE – In regenerators, the A1, A2 and J0 bytes may be relayed (i.e. passed transparently through the regenerator) instead of being terminated and generated as described below. Refer to Recommendation G.958.

Symbol

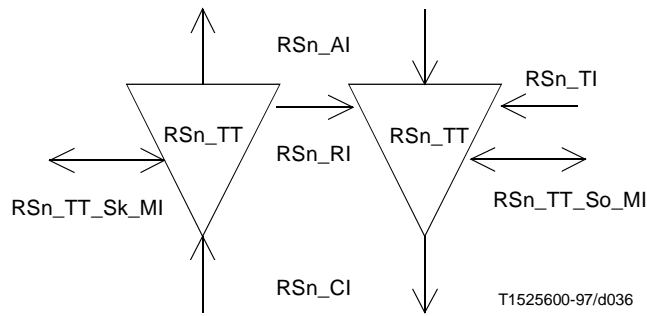

Figure 4-4/G.783 – Regenerator section termination function

4.2.1 Source direction

Symbol

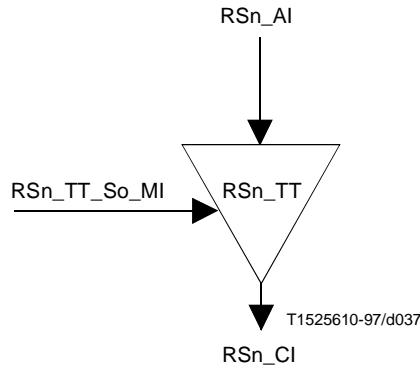

Figure 4-5/G.783 – RSn_TT_So function

Interfaces

Table 4-2/G.783 – RSn_TT_So function inputs and outputs

Input(s)	Output(s)
RSn_AI_Data RSn_AI_Clock $RSn_AI_FrameStart$ $RSn_TT_So_MI_TxTI$	RSn_CI_Data RSn_CI_Clock

Processes

Data at the RSn_AP is an STM-N signal as specified in Recommendation G.707 timed from the $T0$ reference point and having a valid Multiplex Section OverHead (MSOH) and E1, D1-D3, F1 and NU bytes. However, the bytes A1, A2, B1, and J0 are indeterminate in this signal. A1, A2, B1, and J0 bytes are set in accordance with Recommendation G.707 as part of the RSn_TT function to give a fully formatted STM-N data and associated timing at the RSn_CP . After these bytes have been set, the RSn_TT function scrambles the STM-N signal before it is presented to the RSn_CP . Scrambling is performed according to Recommendation G.707, which excludes the first row of the STM-N RSOH ($9 \times N$ bytes, including the A1, A2, J0 and bytes reserved for national use or future international standardization) from scrambling.

A1, A2: Frame alignment bytes A1 and A2 ($3 \times N$ of each) are generated and inserted in the first row of the RSOH.

J0: Regenerator section trace information ($RSn_TT_So_MI_TxTI$) derived from reference point RSn_TT_MP is placed in J0 byte position. The RS trace format is described in Recommendation G.707.

B1: The error monitoring byte B1 is allocated in the STM-N for a regenerator section bit error monitoring function. This function shall be a Bit Interleaved Parity 8 (BIP-8) code using even parity as defined in Recommendation G.707. The BIP-8 is computed over all bits of the previous STM-N frame at the RSn_CP after scrambling. The result is placed in byte B1 position of the RSOH before scrambling.

Defects

None.

Consequent actions

None.

Defect correlations

None.

Performance monitoring

None.

4.2.2 Sink direction

Symbol

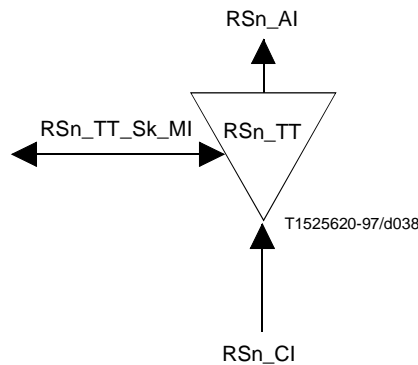

Figure 4-6/G.783 – RSn_TT_Sk function

Interfaces

Table 4-3/G.783 – RSn_TT_Sk function inputs and outputs

Input(s)	Output(s)
RSn_CI_Data RSn_CI_Clock $RSn_CI_FrameStart$ RSn_CI_SSF $RSn_TT_Sk_MI_ExTI$ $RSn_TT_Sk_MI_TPmode$ $RSn_TT_Sk_MI_TIMdis$ $RSn_TT_Sk_MI_ExTImode$ $RSn_TT_Sk_MI_1second$	RSn_AI_Data RSn_AI_Clock $RSn_AI_FrameStart$ RSn_AI_TSF $RSn_TT_Sk_MI_AcTI$ $RSn_TT_Sk_MI_cTIM$ $RSn_TT_Sk_MI_pN_EBC$ $RSn_TT_Sk_MI_pN_DS$

Processes

Fully formatted and regenerated STM-N data and associated timing is received at the RSn_CP from the OSn/RSn_A or ESn/RSn_A function. The B1 bytes are terminated before presenting the framed STM-N data and timing at the RSn_AP .

J0: Bytes J0 (RS path trace) is recovered from the RSOH at the RSn_CP . If an RS trace identifier mismatch ($RSn_TT_Sk_MI_cTIM$) is detected, then it shall be reported via reference point RS_TT_MP . The accepted value of J0 ($RSn_TT_Sk_MI_AcTI$) is also available at the RS_TT_MP . For a description of trace identifier mismatch processing (J0), see 2.2.2.4.

B1: Even bit parity is computed for each bit n of every byte of the preceding scrambled STM-N frame and compared with bit n of B1 recovered from the current frame ($n = 1$ to 8 inclusive). For the case of STM-1, a difference between the computed and recovered B1 values is taken as evidence of one errored block (nN_B). For the case of STM-4 and STM-16, the definition of errored block is for further study.

Defects

dTIM: See 2.2.

Consequent actions

The function shall perform the following consequent actions:

aAIS \leftarrow CI_SSF or dTIM

aTSF \leftarrow CI_SSF or dTIM

Defect correlations

The function shall perform the following defect correlations to determine the most probable fault cause. This fault cause shall be reported to the SEMF.

cTIM \leftarrow dTIM and MON

Performance monitoring

The function shall perform the following performance monitoring primitives processing:

pN_DS \leftarrow aTSF or dEQ

pN_EBC \leftarrow $R\sum nN_B$

4.3 Adaptation

4.3.1 RSn/MSn_A

The information flows associated with the RSn/MSn adaptation function are described with reference to Figures 4-7 and 4-8 and Tables 4-4 and 4-5.

4.3.1.1 Source direction

Symbol

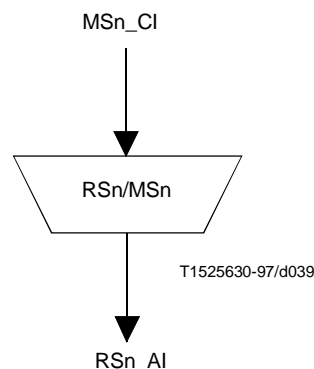

Figure 4-7/G.783 – Fonction RSn/MSn_A_So

Interfaces

Table 4-4/G.783 – RSn/MSn_A_So function inputs and outputs

Input(s)	Output(s)
MSn_CI_Data MSn_CI_Clock MSn_CI_FrameStart MSn_CI_SSF	RSn_AI_Data RSn_AI_Clock RSn_AI_FrameStart

Processes

The function multiplexes the MSn_CI data into the STM-N byte locations defined in Recommendation G.707.

On declaration of aAIS the function shall output all-ONES signal within 250 μs; on clearing of aAIS the function shall output normal data within 250 μs. The frequency of the all-ONES signal shall be within 155 520 kHz ± 20 ppm.

Defects

None.

Consequent actions

aAIS ← CI_SSF

NOTE – If CI_SSF is not connected (when RSn/MSn_A_So is connected to an MSn_TT_So), SSF is assumed to be false.

Defect correlations

None.

Performance monitoring

None.

4.3.1.2 Sink direction

Symbol

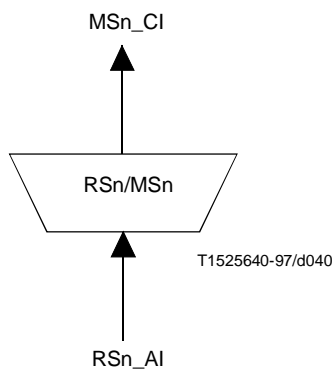

Figure 4-8/G.783 – RSn/MSn_A_Sk function

Interfaces

Table 4-5/G.783 – RSn/MSn_A_Sk function inputs and outputs

Input(s)	Output(s)
RSn_AI_Data RSn_AI_Clock RSn_AI_FrameStart RSn_AI_TSF	MSn_CI_Data MSn_CI_Clock MSn_CI_FrameStart MSn_CI_SSF

Processes

The function separates MSn_CI data from RSn_AI as depicted in Figures 4-1 and 4-2.

Defects

None.

Consequent actions

aSSF ← AI_TSF

Defect correlations

None.

Performance monitoring

None.

4.3.2 RSn/DCC_A

The information flows associated with the RSn/DCC_A function are described with reference to Figures 4-9 and 4-10 and Tables 4-6 and 4-7.

4.3.2.1 Source direction

Symbol

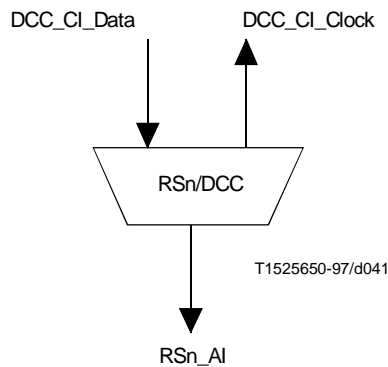

Figure 4-9/G.783 – RSn/DCC_A_So function

Interfaces

Table 4-6/G.783 – RSn/DCC_A_So function inputs and outputs

Input(s)	Output(s)
DCC_CI_Data RSn_AI_Clock RSn_AI_FrameStart	RSn_AI_Data DCC_CI_Clock

Processes

The three data communications channel bytes derived from the message communications function at reference point N are placed in bytes D1-D3 positions of the RSOH. These bytes are allocated for data communication and shall be used as one 192 kbit/s message-oriented channel for alarms, maintenance, control, monitor, administration, and other communication needs between RST functions. This channel is available for internally generated, externally generated, and manufacturer specific messages. The protocol stack used shall be as specified in Recommendation G.784.

Defects

None.

Consequent actions

None.

Defect correlations

None.

Performance monitoring

None.

4.3.2.2 Sink Direction

Symbol

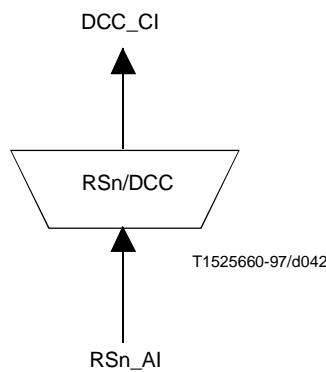

Figure 4-10/G.783 – RSn/DCC_A_Sk function

Interfaces

Table 4-7/G.783 – RSn/DCC_A_Sk function inputs and outputs

Input(s)	Output(s)
RSn_AI_Data RSn_AI_Clock RSn_AI_FrameStart RSn_AI_TSF	DCC_CI_Data DCC_CI_Clock DCC_CI_SSF

Processes

The data communications channel bytes D1-D3 are recovered from the RSOH and passed to the message communications function at reference point N.

Defects

None.

Consequent actions

aSSF ← AI_TSF

Defect correlations

None.

Performance monitoring

None.

4.3.3 RSn/OW_A

The information flows associated with the RSn/OW_A function are described with reference to Figures 4-11 and 4-12 and Tables 4-8 and 4-9.

4.3.3.1 Source direction

Symbol

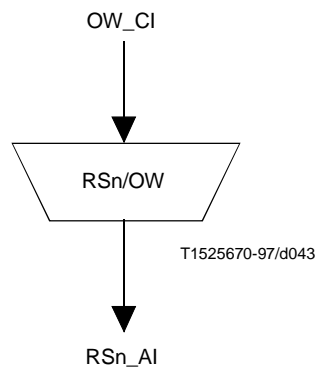

Figure 4-11/G.783 – RSn/OW_A_So function

Interfaces

Table 4-8/G.783 – RSn/OW_A_So function inputs and outputs

Input(s)	Output(s)
OW_CI_Data OW_CI_Clock OW_CI_FrameStart	RSn_AI_Data

Processes

The order-wire byte E1 derived from the OHA function at reference point U1 is placed in byte E1 position of the RSOH. It provides an optional 64 kbit/s unrestricted channel and is reserved for voice communication between network elements.

Defects

None.

Consequent actions

None.

Defect correlations

None.

Performance monitoring

None.

4.3.3.2 Sink direction

Symbol

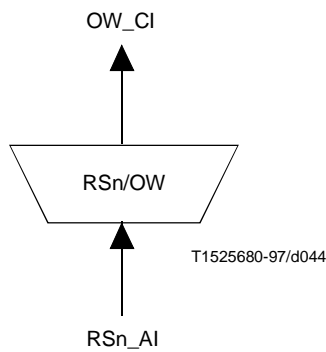

Figure 4-12/G.783 – RSn/OW_A_Sk function

Interfaces

Table 4-9/G.783 – RSn/OW_A_Sk function inputs and outputs

Input(s)	Output(s)
RSn_AI_Data	OW_CI_Data OW_CI_Clock OW_CI_FrameStart

Processes

The order-wire byte E1 is recovered from the RSOH and passed to the OHA function at reference point U1.

On declaration of aAIS the function shall output an all-ONEs (AIS) signal – complying to the frequency limits for this signal (a bit rate in range 64 kbit/s ± 100 ppm) within 2 frames (250 microseconds). Upon termination of the above failure conditions the all-ONEs shall be removed within two frames (250 microseconds).

Defects

None.

Consequent actions

aSSF ← AI_TSF

aAIS ← AI_TSF

Defect correlations

None.

Performance monitoring

None.

4.3.4 RSn/User_A

The information flows associated with the RSn/User_A function are described with respect to Figures 4-13 and 4-14 and Tables 4-10 and 4-11.

4.3.4.1 Source direction

Symbol

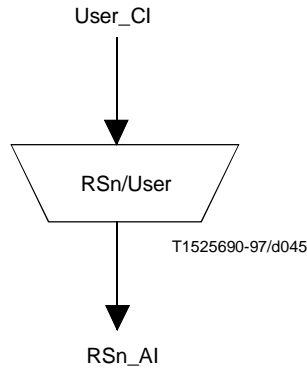

Figure 4-13/G.783 – RSn/User_A_So function

Interfaces

Table 4-10/G.783 – RSn/User_A_So function inputs and outputs

Input(s)	Output(s)
User_CI_Data User_CI_Clock	RSn_AI_Data

Processes

The user channel byte F1 derived from the OHA function at reference point U1 is placed in byte F1 position of the RSOH. It is reserved for the network provider (for example, for network operations). Access to the F1 byte is optional at regenerators. User channel specifications are for further study. Special usage, such as the identification of a failed section in a simple backup mode while the operations support system is not deployed or not working, is for further study. An example of such usage is given in Appendix I.

Defects

None.

Consequent actions

None.

Defect correlations

None.

Performance monitoring

None.

4.3.4.2 Sink direction

Symbol

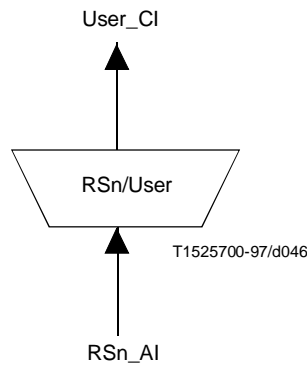

Figure 4-14/G.783 – RSn/User_A_Sk function

Interfaces

Table 4-11/G.783 – RSn/User_A_Sk function inputs and outputs

Input(s)	Output(s)
<i>RSn_AI_Data</i> <i>RSn_AI_Clock</i> <i>RSn_AI_FrameStart</i> <i>RSn_AI_TSF</i>	<i>User_CI_Data</i> <i>User_CI_Clock</i> <i>User_CI_SSF</i>

Processes

The user channel byte F1 is recovered from the RSOH and passed to the OHA function at reference point U1.

Defects

None.

Consequent actions

aSSF ← AI_TSF

aAIS ← AI_TSF

On declaration of aAIS the function shall output an all-ONES (AIS) signal – complying to the frequency limits for this signal (a bit rate in range 64 kbit/s ± 100 ppm) within 2 frames (250 microseconds). Upon termination of the above failure conditions the all-ONES shall be removed within two frames (250 microseconds).

Defect correlations

None.

Performance monitoring

None.

4.3.5 RSn/AUX_A

Certain RSOH bytes are presently reserved for national use, media-dependent use or for future international standardization, as defined in Recommendation G.707. One or more of these bytes may be derived from the OHA function at reference point U1. The unused bytes in the first row of the STM-N signal, which are not scrambled for transmission, shall be set to 10101010 when not used for a particular purpose. No pattern is specified for the other unused bytes when not used for a particular purpose.

One or more of the bytes for national use or future international standardization may be recovered from the STM-N and may be passed to the OHA function at reference point U1. The RS_n/AUX_A function shall be capable of ignoring these bytes.

4.4 Sublayer functions (N/A)

5 Multiplex section layer

The data at the Multiplex Section Layer CP is octet structured with co-directional timing and 125 microsecond frame length. The format is shown in Figures 5-1, 5-2 and 5-3.

The MS CI consists of the B2 BIP-24 byte, the E2 orderwire byte, the K1/K2 APS bytes, the D4-D12 MS DCC bytes, the S1 SSM byte and the NU bytes, together with the S_n CI as defined in Recommendation G.707.

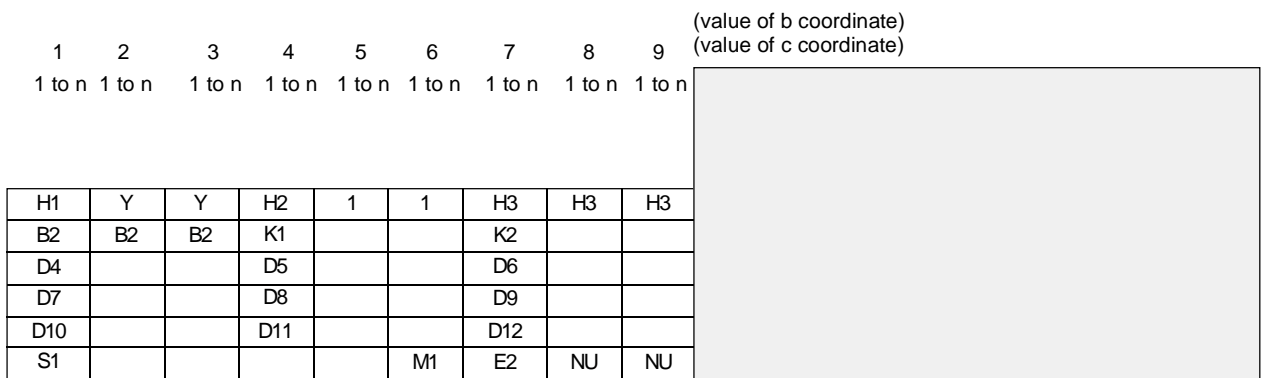

T1525710-97/d047

Figure 5-1/G.783 – Multiplex section CI data format

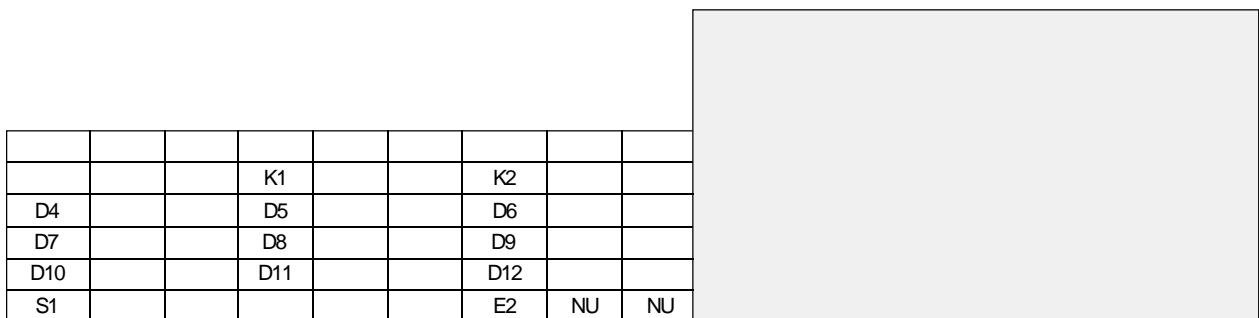

T1525720-97/d048

Figure 5-2/G.783 – Multiplex section AI data format

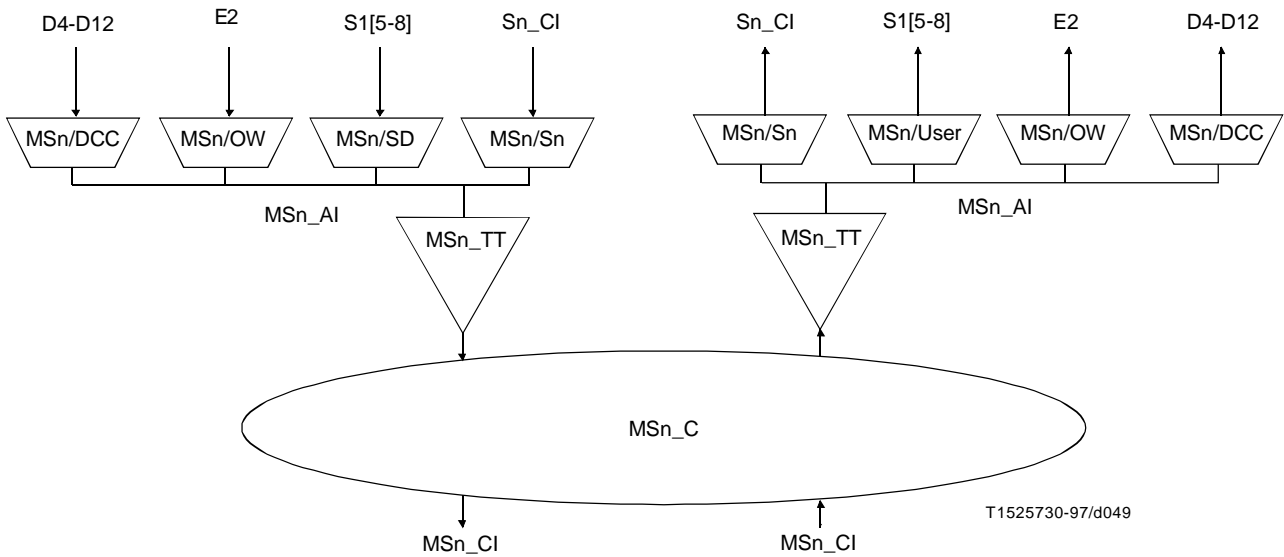

Figure 5-3/G.783 – Multiplex section function

Relationship to previous versions of Recommendation G.783

The 1994 version of Recommendation G.783 refers to the MST, MSP and MSA basic functions. Table 5-1 shows the relationship between the basic functions and the atomic functions in the Multiplex Section layer.

Table 5-1/G.783 – Multiplexer section layer basic and atomic functions

Basic function	Atomic function
MST	MSn_TT MSn/DCC_A MSn/OW_A MSn/Aux_A MSn/SD_A
MSP	MSnP_TT MSnP_A MSnP_C
MSA	MSn/Sn_A

5.1 Connection (N/A)

5.2 Termination: MSn_TT

The MSn_TT function acts as a source and sink for the B2 and M1 bytes of the Multiplex Section OverHead (MSOH). The information flows associated with the MSn_TT function are described with reference to Figures 5-4, 5-5 and 5-6 and Tables 5-2 and 5-3.

Symbol

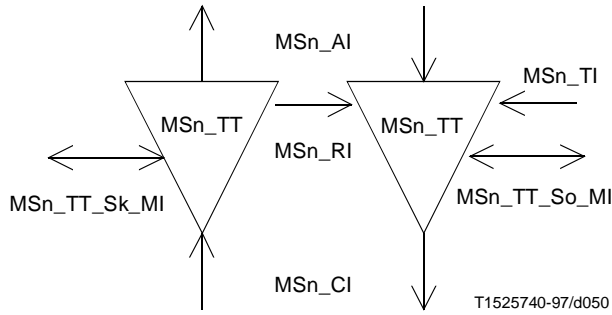

Figure 5-4/G.783 – Multiplex section termination function

5.2.1 Source direction

Symbol

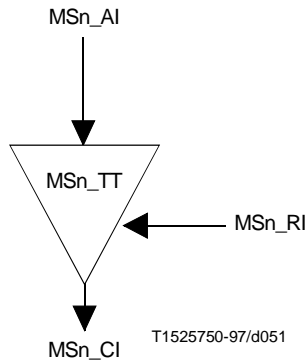

Figure 5-5/G.783 – MSn_TT_So function

Interfaces

Table 5-2/G.783 – MSn_TT_So function inputs and outputs

Inputs	Outputs
MSn_AI_Data MSn_AI_Clock MSn_AI_FrameStart MSn_RI_RDI MSn_RI_REI	MSn_CI_Data MSn_CI_Clock MSn_CI_FrameStart

Processes

Data at the MSn_AP is an STM-N signal as specified in Recommendation G.707 timed from the T0 reference point, having a payload constructed as in Recommendation G.707, but with indeterminate B2 and M1 MSOH bytes and indeterminate RSOH bytes. The B2 and M1 bytes are set in accordance with Recommendation G.707 as part of the MSn_TT_So function. The resulting STM-N data and associated timing are presented at the MSn_CP.

B2: The error monitoring byte B2 is allocated in the STM-N for a multiplex section bit error monitoring function. This function shall be a bit interleaved parity (BIP-24N) code using even parity as defined in Recommendation G.707. The BIP-24N is computed over all bits (except those in the RSOH bytes) of the previous STM-N frame and placed in the $3 \times N$ respective B2 byte positions of the current STM-N frame.

M1: The number of errors detected by monitoring B2 in the sink side (see 3.3.1) is passed to the source side via the aREI and is encoded in the MS-REI (byte M1) according to 9.2.2.12/G.707.

K2[6-8]: These bits represent the defect status of the associated MSn_TT_Sk . The indication shall be set to 110 within 250 microseconds following activation of the MSn_RI_RDI by the MSn_TT_Sk . The indication shall be set to 000 upon clearing of the MSn_RI_RDI .

Defects

None.

Consequent actions

If an MS-AIS defect at the MSn_AP (see 3.3.2) is detected in the sink side, then it is passed to the source side via the aRDI (part of the MSn_RI) and MS-RDI shall be applied within 250 microseconds at the data signal output at reference point MSn_CP . MS-RDI is defined as an STM-N signal with the code 110 in bit positions 6, 7 and 8 of byte K2. On clearing of the defect the function shall output normal data within 250 microseconds.

Defect correlations

None.

Performance monitoring

None.

5.2.2 Sink direction

Symbol

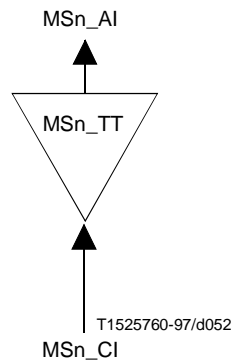

Figure 5-6/G.783 – MSn_TT_Sk function

Interfaces

Table 5-3/G.783 – MS_n_TT_Sk function inputs and outputs

Inputs	Outputs
MS _n _CI_Data	MS _n _AI_Data
MS _n _CI_Clock	MS _n _AI_Clock
MS _n _CI_FrameStart	MS _n _AI_FrameStart
MS _n _CI_SSF	MS _n _AI_TSF
	MS _n _AI_TSD
MS _n _TT_Sk_MI_DEGTHR	MS _n _TT_Sk_MI_cAIS
MS _n _TT_Sk_MI_DEGM	MS _n _TT_Sk_MI_cDEG
MS _n _TT_Sk_MI_DEG_X	MS _n _TT_Sk_MI_cRDI
MS _n _TT_Sk_MI_EXC_X	MS _n _TT_Sk_MI_cSSF
MS _n _TT_Sk_MI_1secondpulse	MS _n _TT_Sk_MI_cEXC
MS _n _TT_Sk_MI_TPMode	MS _n _TT_Sk_MI_pNEBC
MS _n _TT_Sk_MI_AIS_Reported	MS _n _TT_Sk_MI_pFEBC
MS _n _TT_Sk_SSF_Reported	
MS _n _TT_Sk_MI_RDI_Reported	MS _n _TT_Sk_MI_pNDS
MS _n _TT_Sk_AIS_Reported	
MS _n _TT_Sk_RDI_Reported	MS _n _TT_Sk_MI_pFDS

Processes

The MS_n_CI is received at reference point MS_n_CP. The MS_n_TT function recovers the B2, M1, and K2[6-8] bytes. Then, the STM-N data and associated timing are presented at reference point MS_n_AP.

B2: The 3 x N error monitoring B2 bytes are recovered from the MSOH. A BIP-24N code is computed for the STM-N frame. The computed BIP-24N value for the current frame is compared with the recovered B2 bytes from the following frame and errors are reported at reference point MS_n_TT_MP as number of errors within the B2 bytes per frame for performance monitoring filtering in the synchronous equipment management function. The BIP-24N errors are also processed within the MS_n_TT function to detect Signal Degrade (SD) defect. The process for detecting signal degrade is described in 2.2.4.1.

M1: MS-REI information is decoded from byte M1 and reported as a 1 second count (pF_EBC) at the MS_n_TT_MP.

Defects

dAIS: An MS-AIS defect shall be detected by the MS_n_TT function when the pattern 111 is observed in bits 6, 7 and 8 of byte K2 in at least three consecutive frames. Removal of the MS-AIS defect shall take place when any pattern other than the code 111 in bits 6, 7 and 8 of byte K2 received in at least three consecutive frames.

dRDI: See 2.2.

dDEG: See 2.2.

dEXC: See 2.2.

Consequent actions

The function shall perform the following consequent actions:

aAIS	←	dAIS
aRDI	←	dAIS
aREI	←	Σ nN_B
aTSF	←	dAIS
aTSD	←	dDEG
aTSFprot	←	aTSF or dEXC

The MS-AIS and MS-RDI defects shall be reported at reference point MSn_TT_MP for alarm filtering in the synchronous equipment management function. If MS-AIS defect is detected, then a logical all-ONEs (AIS) data signal shall be applied at reference point MSn_AP within 250 microseconds. Upon termination of the above defect condition, the logical all-ONEs signal shall be removed within 250 microseconds.

If MS-AIS is detected, then a Trail Signal Fail (TSF) condition shall be applied at reference point MSn_AP within 250 microseconds. Upon termination of the above defect conditions, the signal fail condition shall be removed within 250 microseconds.

If MS-DEG is detected, then a Trail Signal Degrade (TSD) condition shall be applied at the MSn_AP within 250 microseconds. Upon termination of the above defect condition, the TSD condition shall be removed within 250 microseconds.

Defect correlations

The function shall perform the following defect correlations to determine the most probable fault cause. This fault cause shall be reported to the SEMF.

- cAIS ← dAIS and (not SSF) and AIS_Reported and MON
- cDEG ← dDEG and MON
- cRDI ← dRDI and RDI_Reported and MON
- cEXC ← dEXC and MON

Performance monitoring

The function shall perform the following performance primitives processing:

- pN_DS ← aTSF or dEQ
- pF_DS ← dRDI
- pN_EBC ← $\sum nN_B$
- pF_EBC ← $\sum nF_B$

5.3 Adaptation

5.3.1 MSn/Sn_A

This function provides adaptation of higher order paths into Administrative Units (AUs), assembly and disassembly of AU groups, byte interleaved multiplexing and demultiplexing, and pointer generation, interpretation and processing. The signal flow associated with the MSn/Sn_A function is described with reference to Figures 5-7 and 5-8 and Tables 5-4 and 5-5.

5.3.1.1 Source direction

Symbol

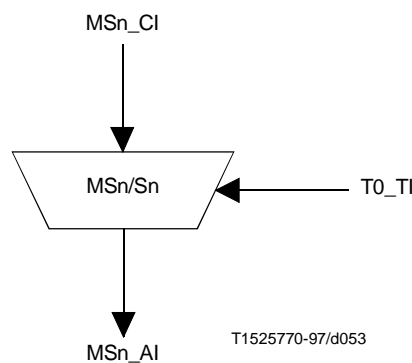

Figure 5-7/G.783 – MSn/Sn_A_So function

Interfaces

Table 5-4/G.783 – MSn/Sn_A_So function inputs and outputs

Inputs	Outputs
<i>Sn_CI_Data</i> <i>Sn_CI_Clock</i> <i>Sn_CI_FrameStart</i> <i>Sn_CI_SSF</i>	<i>MSn_AI_Data</i> <i>MSn_AI_Clock</i> <i>MSn_AI_FrameStart</i>
<i>T0_TI_Clock</i> <i>T0_TI_FrameStart</i>	<i>MSn/Sn_A_So_MI_pPJE+</i> <i>MSn/Sn_A_So_MI_pPJE-</i>

Processes

The PP function provides accommodation for wander and plesiochronous offset in the received signal with respect to the synchronous equipment timing reference. This function may be null in some applications where the timing reference is derived from the incoming STM-N signal, i.e. loop timing or if the HP container is generated with the same timing source as the multiplex section.

The PP function can be modelled as a data buffer which is being written with data, timed from the received VC clock, and read by a VC clock derived from reference point T0. When the write clock rate exceeds the read clock rate the buffer gradually fills and vice versa. Upper and lower buffer occupancy thresholds determine when pointer adjustment should take place. The buffer is required to reduce the frequency of pointer adjustments in a network. The pointer hysteresis threshold spacing allocation is specified in 10.1.4.1. When the data in the buffer rise above the upper threshold for a particular VC, the associated frame offset is decremented by one byte for a VC-3 or three bytes for a VC-4, and the corresponding number of bytes is read from the buffer. When the data in the buffer fall below the lower threshold for a particular VC, the associated frame offset is incremented by one byte for a VC-3 or three bytes for a VC 4 and the corresponding number of read opportunities is cancelled.

It may be possible to detect network synchronization degradation by monitoring pointer increments and decrements. Outgoing Pointer Justification Events (PJE), i.e. pointer values that have been either incremented or decremented, are counted and reported at reference point *MSn/Sn_A_MP* for performance monitoring filtering. PJE counts are to be reported separately for pointer increments (positive events) and decrements (negative events). PJE need only be reported for one selected AU-3/4 out of an STM-N signal.

The higher order paths at the *Sn_CP* are mapped into AUs which are incorporated into AU groups. N such AUGs are byte interleaved to form an STM-N payload at the *MSn_AP*. The byte interleaving process shall be as specified in Recommendation G.707. The frame offset information is used by the PG function to generate pointers according to pointer generation rules in Recommendation G.707. STM-N data, in the *MSn_AP*, is synchronized to timing from the T0 reference point.

Defects

None.

Consequent actions

The function shall perform the following consequent actions:

aAIS ← SSF

When an all-ONEs signal is applied at reference point *Sn_CP*, an all-ONEs (AU-AIS) signal shall be applied at reference point *MSn_AP* within 2 frames (250 microseconds). Upon termination of the all-ONEs signal at the *Sn_CP*, the all-ONEs (AU-AIS) signal shall be terminated within 2 frames (250 microseconds).

Defect correlations

None.

Performance monitoring

Every second, the number of generated pointer justification increments within that second shall be counted as the pPJE+. Every second, the number of generated pointer justification decrements within that second shall be counted as the pPJE-.

5.3.1.2 Sink direction

Symbol

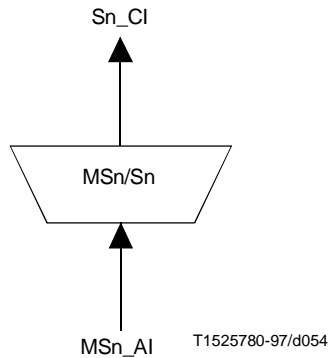

Figure 5-8/G.783 – MSn/Sn_A_Sk function

Interfaces

Table 5-5/G.783 – MSn/Sn_A_Sk function inputs and outputs

Inputs	Outputs
MSn_AI_Data MSn_AI_Clock MSn_AI_FrameStart MSn_AI_TSF	Sn_CI_Data Sn_CI_Clock Sn_CI_FrameStart Sn_CI_SSF
MSn/Sn_A_Sk_MI_AIS_Reported	MSn/Sn_A_Sk_MI_cAIS MSn/Sn_A_Sk_MI_cLOP

Processes

The algorithm for pointer detection is defined in Annex C. Two defect conditions can be detected by the pointer interpreter:

- Loss of Pointer (LOP);
- AU-AIS.

If either of these defect conditions are detected, then a logical all-ONEs (AIS) signal shall be applied at reference point Sn_CP within 2 frames (250 μs). Upon termination of these defects, the all-ONEs signal shall be removed within 2 frames (250 μs). These defects shall be reported at reference point MS/Sn_A_MP for alarm filtering at the synchronous equipment management function.

It should be noted that a persistent mismatch between provisioned and received AU type will result in a LOP defect and also that AU-3 and AU-4 structures can be differentiated by checking the Y bytes in the pointer area.

S_n payloads received at the MS_n_AP are de-interleaved and the phase of the VC-3/4s recovered using the AU pointers. The latter process must allow for the case of continuously variable frame offset which occurs when the received STM-N signal has been derived from a source which is plesiochronous with the local clock reference. The algorithm for pointer interpretation is given in C.3.

Defects

dAIS: See Annex C.

dLOP: See Annex C.

Consequent actions

The function shall perform the following consequent actions:

aAIS ← dAIS or dLOP

aSSF ← dAIS or dLOP

When an SF condition is present at the MS_n_AP , an SF condition shall be applied at the S_n_CP within 250 microseconds. Upon termination of the above defect condition at the MS_n_AP , the SF condition shall be removed within 250 microseconds.

Defect correlations

The function shall perform the following defect correlations to determine the most probable fault cause. This fault cause shall be reported to the SEMF.

cAIS ← dAIS and (not TSF) and AIS_Reported

cLOP ← dLOP

Performance monitoring

None.

5.3.2 MS_n/DCC_A

The MS_n/DCC_A adaptation function multiplexes the D4-D12 bytes of the Multiplex Section OverHead (MSOH) into the MS_n_AI in the source direction and demultiplexes the D4-D12 bytes from the MS_n_AI in the sink direction. The information flows associated with the MS_n/DCC_A function are described with reference to Figures 5-9 and 5-10 and Tables 5-6 and 5-7.

5.3.2.1 Source direction

Symbol

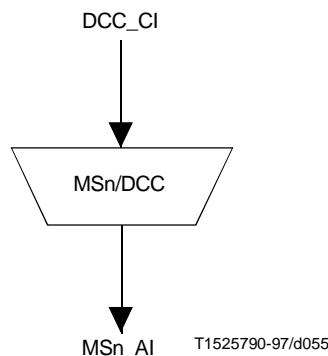

Figure 5-9/G.783 – MS_n/DCC_A_So function

Interfaces

Table 5-6/G.783 – MSn/DCC_A_So function inputs and outputs

Inputs	Outputs
DCC_CI_Data STM-N_TI_FrameStart STM-N_TI_Clock	MSn_CI_Data DCC_CI_Clock

Processes

The nine data communications channel bytes issued by the message communications function via the P reference point are placed consecutively in the D4 to D12 byte positions. This should be considered as a single message-based channel for alarms, maintenance, control, monitoring, administration, and other communication needs. It is available for internally generated, externally generated, and manufacturer specific messages. The protocol stack used shall be in accordance with the specifications given in Recommendation G.784. Regenerators are not required to access this DCC. The nine DCC bytes may alternatively be issued by the overhead access function via the U2 reference point to provide a transparent data channel by using an appropriate OHA interface.

Defects

None.

Consequent actions

None.

Defect correlations

None.

Performance monitoring

None.

5.3.2.2 Sink direction

Symbol

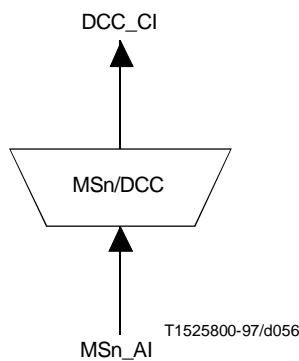

Figure 5-10/G.783 – MSn/DCC_A_Sk function

Interfaces

Table 5-7/G.783 – MSn/DCC_A_Sk function inputs and outputs

Inputs	Outputs
MSn_AI_Data MSn_AI_Clock MSn_AI_FrameStart MSn_AI_TSF	DCC_CI_Data DCC_CI_Clock DCC_CI_SSF

Processes

The multiplex section data communications channel bytes D4 to D12 are recovered from the MS_AI and are passed to the message communications function at reference point P. Alternatively, they may be passed to the overhead access function via reference point U2.

Defects

None.

Consequent actions

aSSF ← dTSF

Defect correlations

None.

Performance monitoring

None.

5.3.3 MSn/OW_A

The MSn/OW_A adaptation function multiplexes the E2 bytes of the Multiplex Section OverHead (MSOH) into the MSn_AI in the source direction and demultiplexes the E2 bytes from the MSn_AI in the sink direction. The information flows associated with the MSn/OW_A function are described with reference to Figures 5-11 and 5-12 and Tables 5-8 and 5-9.

5.3.3.1 Source direction

Symbol

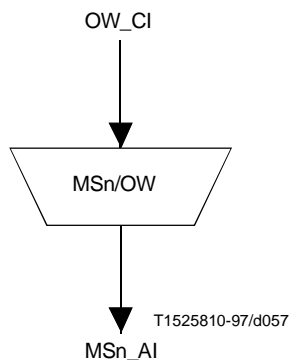

Figure 5-11/G.783 – MSn/OW_A_So function

Interfaces

Table 5-8/G.783 – MSn/OW_A_So function inputs and outputs

Inputs	Outputs
OW_CI_Data OW_CI_Clock OW_CI_FrameStart	MSn_AI_Data

Processes

The order-wire byte is issued by the OHA function at reference point U2 and is placed in the E2 byte position. It provides an optional 64 kbit/s unrestricted channel and is reserved for voice communications between terminal locations.

Defects

None.

Consequent actions

None.

Defect correlations

None.

Performance monitoring

None.

5.3.3.2 Sink direction

Symbol

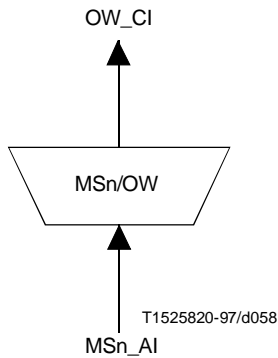

Figure 5-12/G.783 – MSn/OW_A_Sk function

Interfaces

Table 5-9/G.783 – MSn/OW_A_Sk function inputs and outputs

Inputs	Outputs
MSn_AI_Data MSn_AI_Clock MSn_AI_FrameStart MSn_AI_TSF	OW_CI_Data OW_CI_Clock OW_CI_FrameStart OW_CI_SSF

Processes

The order-wire byte E2 is recovered from the MS_AI and is passed to the OHA function at reference point U2.

Defects

None.

Consequent actions

aSSF ← dTSF

Defect correlations

None.

Performance monitoring

None.

5.3.4 MSn/SD_A

The information flows associated with the MSn/SD_A function are described with reference to Figures 5-13 and 5-14 and Tables 5-10 and 5-11.

5.3.4.1 Source direction

Symbol

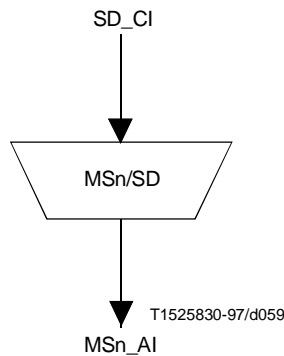

Figure 5-13/G.783 – MSn/SD_A_So function

Interfaces

Table 5-10/G.783 – MSn/SD_A_So function inputs and outputs

Inputs	Outputs
SD_CI_Data	MSn_AI_Data SD_CI_Clock SD_CI_SSF

Processes

Bits 5-8 of the byte S1(9.1.1) are set to indicate the synchronization status message. These bits are coded per Recommendation G.707 based on the synchronization quality level indicated by the Y reference point.

Defects

None.

Consequent actions

None.

Defect correlations

None.

Performance monitoring

None.

5.3.4.2 Sink direction

Symbol

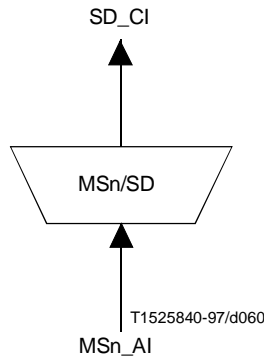

Figure 5-14/G.783 – MSn/SD_A_Sk function

Interfaces

Table 5-11/G.783 – MSn/SD_A_Sk function inputs and outputs

Inputs	Outputs
MSn_AI_Data MSn_AI_Clock MSn_AI_FrameStart MSn_AI_TSF	SD_CI_Data SD_CI_Clock SD_CI_SSF

Processes

The synchronization status message is recovered from bits 5-8 of the byte S1(9.1.1) and the synchronization quality level is reported to the SETS at reference point Y. A persistency check for the detection of the synchronization status message is for further study.

Defects

None.

Consequent actions

aSSF ← dTSF

Defect correlations

None.

Performance monitoring

None.

5.3.5 MS_n/AUX_A

Certain MSOH bytes are presently reserved for national use, media dependent use or for future international standardization, as defined in Recommendation G.707. One or more of these bytes may be derived from the OHA function at reference point U1. No pattern is specified for the other unused bytes when not used for a particular purpose.

One or more of the bytes for national use or future international standardization may be recovered from the STM-N and may be passed to the OHA function at reference point U1. The MS_n_TT_Sk function shall be capable of ignoring these bytes.

5.4 Sublayer functions

5.4.1 Multiplex Section Protection (MSP) function

The MSP function provides protection for the STM-N signal against channel-associated failures within a multiplex section, i.e. the RST, SPI functions and the physical medium from one MS_n_TT function where section overhead is inserted to the other MS_n_TT function where that overhead is terminated.

The MSP functions at both ends operate the same way, by monitoring STM-N signals for failures, evaluating the system status taking into consideration the priorities of failure conditions and of external and remote switch requests, and switching the appropriate channel to the protection section. The two MSP functions communicate with each other via a bit-oriented protocol defined for the MSP bytes (K1 and K2 bytes in the MSOH of the protection section). This protocol is described in A.1 or B.1, for the various protection switching architectures and modes.

NOTE – The use of the MSP protocol as described in Annex A and in 5.4.1.1.2 over long multiplex sections such as satellite systems, submarine cable systems, radio relay systems, and transmission systems with a large number of regenerators or optical amplifiers, is for further study. However, the use of MSP over such systems may result in longer switching times due to the additional propagation delay introduced by the physical section. Thus in some applications, it may not be possible to meet the network objective of a 50 ms switching time.

The signal flow associated with the MSP function is described with reference to Table 5-12. The MSP functions receive control parameters and external switch requests at the MSP_MP reference point from the synchronous equipment management function and outputs status indicators at the MSP_MP to the synchronous equipment management function, as a result of switch commands described in A.2 or B.2.

5.4.1.1 MSPC

Interfaces

Table 5-12/G.783 – MS_nP_C function inputs and outputs

Input(s)	Output(s)
For connection points W and P: MS _n P_CI_Data MS _n P_CI_Clock MS _n P_CI_FrameStart MS _n P_CI_SSF MS _n P_CI_SSD MS _n P_C_MI_SFpriority MS _n P_C_MI_SDpriority For connection points N and E: MS _n P_CI_Data MS _n P_CI_Clock MS _n P_CI_FrameStart Per function: MS _n P_CI_APS MS _n P_C_MI_SWtype MS _n P_C_MI_EXTRAttraffic MS _n P_C_MI_WTRTime MS _n P_C_MI_EXTCMD	For connection points W and P: MS _n P_CI_Data MS _n P_CI_Clock MS _n P_CI_FrameStart For connection points N and E: MS _n P_CI_Data MS _n P_CI_Clock MS _n P_CI_FrameStart MS _n P_CI_SSF NOTE – Protection status reporting signals are for further study. Per function: MS _n P_CI_APS MS _n P_C_MI_cFOP MS _n P_C_MI_pPSC MS _n P_C_MI_pPSSw MS _n P_C_MI_pPSSp

Processes

Data at the MSn_AP is an STM-N signal, timed from the T0 reference point, with indeterminate MSOH and RSOH bytes.

In the source direction for 1 + 1 architecture, the signal received at the MSn_AP from the MSn/Sn_A function is bridged permanently at the MSn_AP to both working and protection MSn_TT functions. For 1 : n architecture, the signal received at the MSn_AP from each working MSn/Sn_A is passed at the MSn_AP to its corresponding MSn_TT. The signal from an extra traffic MSn/Sn_A (if provisioned) is connected to the protection MSn_TT. When a bridge is needed to protect a working channel, the signal at the MSn_AP from that working MSn/Sn_A is bridged at the MSn_AP to the protection MSn_TT and the extra traffic channel is terminated.

In the sink direction framed STM-N signals (data) whose RSOH and MSOH bytes have already been recovered are presented at the reference point MSn_AP along with incoming timing references. The failure conditions SF and SD are also received at the reference point MSn_AP from all MSn_TT functions.

Under normal conditions, MSnP_C passes the data and timing from the working MSn_TT functions to their corresponding working MSn/Sn_A functions at the reference point MSn_AP. The data and timing from the protection section is passed to the extra traffic MSn/Sn_A, if provisioned in a 1 : n MSP architecture, or else it is terminated.

If a switch is to be performed, then the data and timing received from the protection MSn_TT at reference point D is switched to the appropriate working channel MSn/Sn_A function at the MSn_AP, and the signal received from the working MSn_TT at the MSn_AP is terminated.

5.4.1.1.1 Switch initiation criteria

Automatic protection switching is based on the failure conditions of the working and protection sections. These conditions, Signal Fail (SF) and Signal Degrade (SD), are provided by the MSn_TT functions at the MSn_AP. Detection of these conditions is described in 5.2.

The protection switch can also be initiated by switch commands received via the synchronous equipment management function.

5.4.1.1.2 Switching time

Protection switching shall be completed within 50 ms of detection of an SF or SD condition that initiates a switch.

Protection switching shall be completed within 50 milliseconds for manual commands (Forced Switch, Manual Switch, or LOCKOUT). This time shall be measured from the time the K1 byte request is issued from the originating network element.

Development of a budget dividing the protection switching time between network elements, transmission delays, and fixed protocol times is a topic for further study.

5.4.1.1.3 Switch restoration

In the revertive mode of operation, the working channel shall be restored, i.e. the signal on the protection section shall be switched back to the working section, when the working section has recovered from failure. Restoration allows other failed working channels or an extra traffic channel to use the protection section.

To prevent frequent operation of the protection switch due to an intermittent failure (e.g. BER fluctuating around the SD threshold), a failed section must become fault-free (i.e. BER less than a restoration threshold). After the failed section meets this criterion, a fixed period of time shall elapse before it is used again by a working channel. This period, called Wait to Restore (WTR) period, should be of the order of 5-12 minutes and should be capable of being set. An SF or SD condition shall override the WTR.

Defects

None.

Consequent actions

For the case that neither an extra traffic nor a normal signal input is to be connected to the protection section output, then either an all-ONEs, an *Sn* unequipped, a working signal input, or other suitable test signal will be connected to the protection section output.

Defect correlations

cFOP ← dTSF

Performance monitoring

pPSC ← Refer to Annex A.

pPSD ← Refer to Annex A.

5.4.1.2 MSnP_TT

5.4.1.2.1 Source direction

Interfaces

See Table 5-13.

Table 5-13/G.783 – MSnP_TT_So function inputs and outputs

Input(s)	Output(s)
MSn_AI_Data MSn_AI_Clock MSn_AI_FrameStart	MSnP_CI_Data MSnP_CI_Clock MSnP_CI_FrameStart

Processes

No information processing is required in the MSnP_TT_So, the MSn_AI at its output being identical to the MSnP_CI at its input.

Defects

None.

Consequent actions

None.

Defect correlations

None.

Performance monitoring

None.

5.4.1.2.2 Sink direction

Interfaces

See Table 5-14.

Table 5-14/G.783 – MSnP_TT_Sk function inputs and outputs

Input(s)	Output(s)
MSnP_CI_Data MSnP_CI_Clock MSnP_CI_FrameStart MSnP_CI_SSF	MSn_AI_Data MSn_AI_Clock MSn_AI_FrameStart MSn_AI_TSF MSnP_TT_Sk_MI_cSSF

Processes

The MSnP_TT_Sk function reports, as part of the MSn layer, the state of the protected MSn trail. In case all connections are unavailable, the MSnP_TT_Sk reports the signal fail condition of the protected trail.

Defects

None.

Consequent actions

aTSF ← CI_SSF

Defect correlations

cSSF ← CI_SSF

Performance monitoring

None.

5.4.1.3 MSn/MSnP_A

5.4.1.3.1 Source direction

Interfaces

See Table 5-15.

Table 5-15/G.783 – MSn/MSnP_A_So function inputs and outputs

Input(s)	Output(s)
MSnP_CI_Data MSnP_CI_Clock MSnP_CI_FrameStart MSnP_CI_APS	MSn_AI_Data MSn_AI_Clock MSn_AI_FrameStart

Processes

The K1 and K2 bytes generated according to the rules in A.1 are presented the MSn_AP to the protection MSn_TT. These bytes may also be presented to the working MSn_TT functions.

Defects

None.

Consequent actions

None.

Defect correlations

None.

Performance monitoring

None.

5.4.1.3.2 Sink direction

Interfaces

See Table 5-16.

Table 5-16/G.783 – MSn/MSnP_A_Sk function inputs and outputs

Input(s)	Output(s)
MSn_AI_Data MSn_AI_Clock MSn_AI_FrameStart MSn_AI_TSF MSn_AI_TSD	MSnP_CI_Data MSnP_CI_Clock MSnP_CI_FrameStart MSnP_CI_SSF MSnP_CI_SSD MSnP_CI_APS (for Protection signal only)

Processes

The recovered K1 and K2 bytes from the protection MST function are presented at the reference point MSn_AP. Working MST functions may also present these bytes to the MSP. The MSP must be able to ignore these bytes from the working MST functions.

Defects

None.

Consequent actions

aSSF ← AI_TSF

aSSD ← AI_TSD

Defect correlations

None.

Performance monitoring

None.

6 Higher order SDH path (Sn) layer

The higher order path layers are those layers in which the signals have a higher order VC-3 (7.1.3/G.707) or a VC-4 (7.1.2/G.707) logical structure. See Figure 6-1.

Higher order Sn layer characteristic information

The Characteristic Information Sn_CI has co-directional timing and is octet structured with a 125 μs frame, as shown in Figures 6-2 to 6-7, left frames. Its format is characterized as the VC-n [n = (3 or 4)] trail termination overhead in the J1, B3, and G1 bytes as defined in Recommendation G.707 plus the Sn Adapted Information given in the next section. Alternatively it may be an unequipped signal as defined in Recommendation G.707.

For the case of a signal within the tandem connection sublayer, the Characteristic Information has defined Sm tandem connection trail termination overhead in location N1 as shown in Figures 6-3, 6-4, 6-6 and 6-7.

Higher order Sn layer adaptation information

The Adaptation Information AI is octet structured with a 125 μs frame as shown in Figures 6-2 to 6-7, right frames. It represents adapted client layer information consisting of client layer information, the signal label, and client specific information combined with 1 byte user channels F2 and F3. For the case the signal has passed the trail protection sublayer (SnP), Sn_AI has defined APS bits (1 to 4) in byte K3.

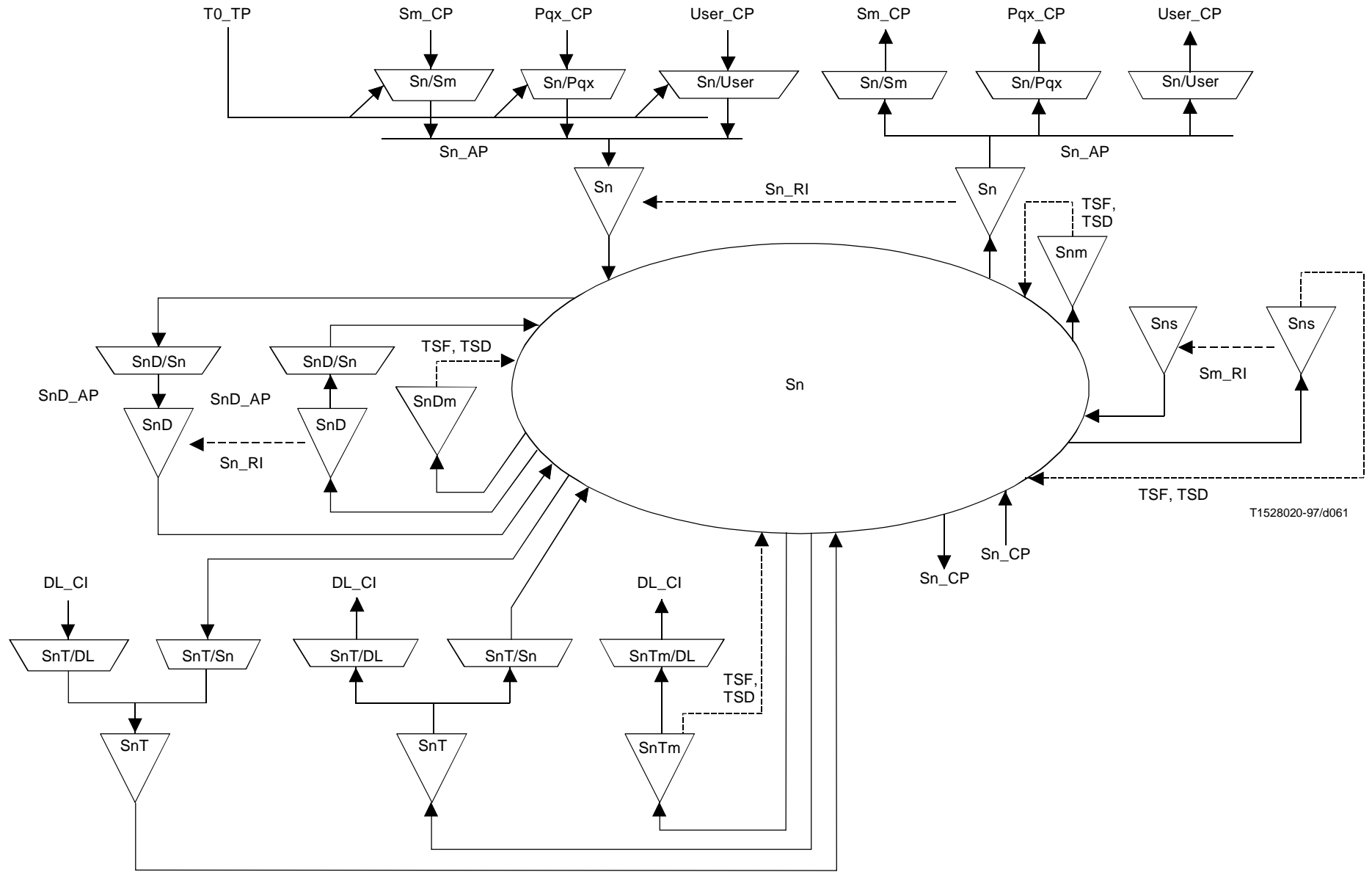

Figure 6-1/G.783 – Higher order path layer atomic functions

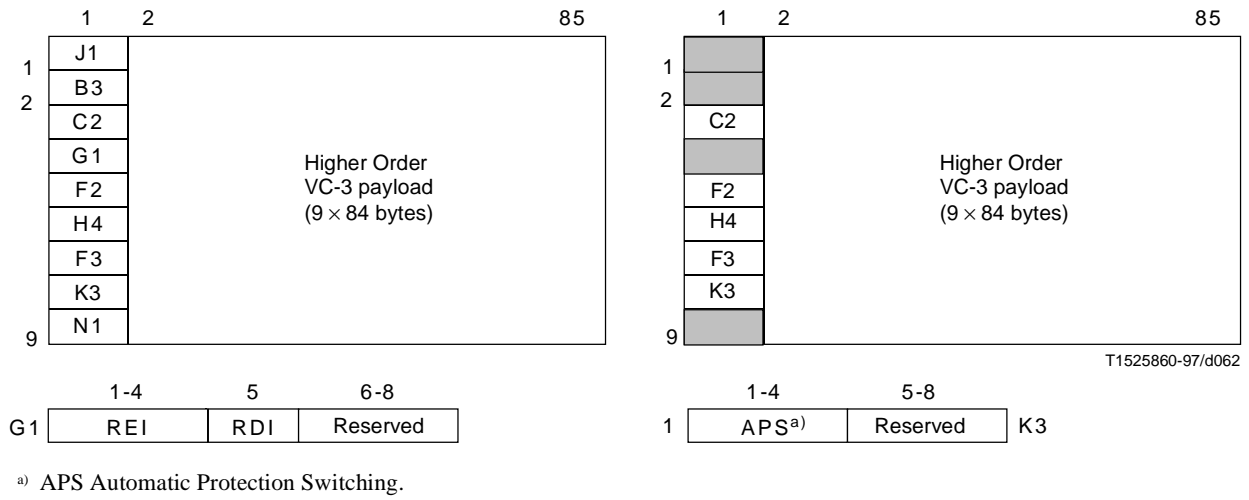

Figure 6-2/G.783 – S3_CI_D (left) and S3_AI_D (right)

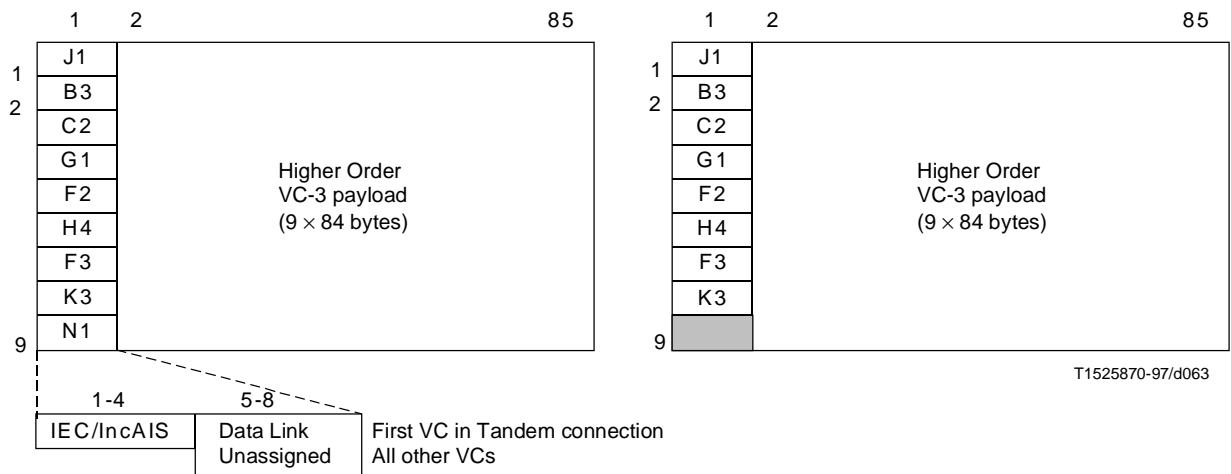

Figure 6-3/G.783 – S3_CI_D (left) with defined N1 and S3T_AI_D (right)

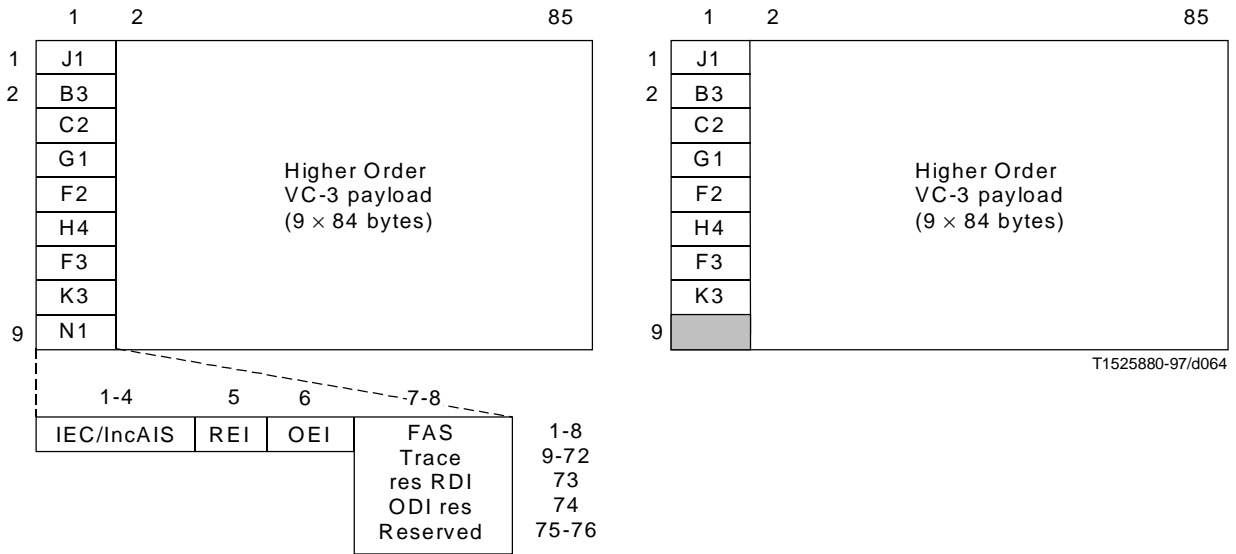

Figure 6-4/G.783 – S3_CI_D (left) with defined N1 and S3D_AI_D (right)

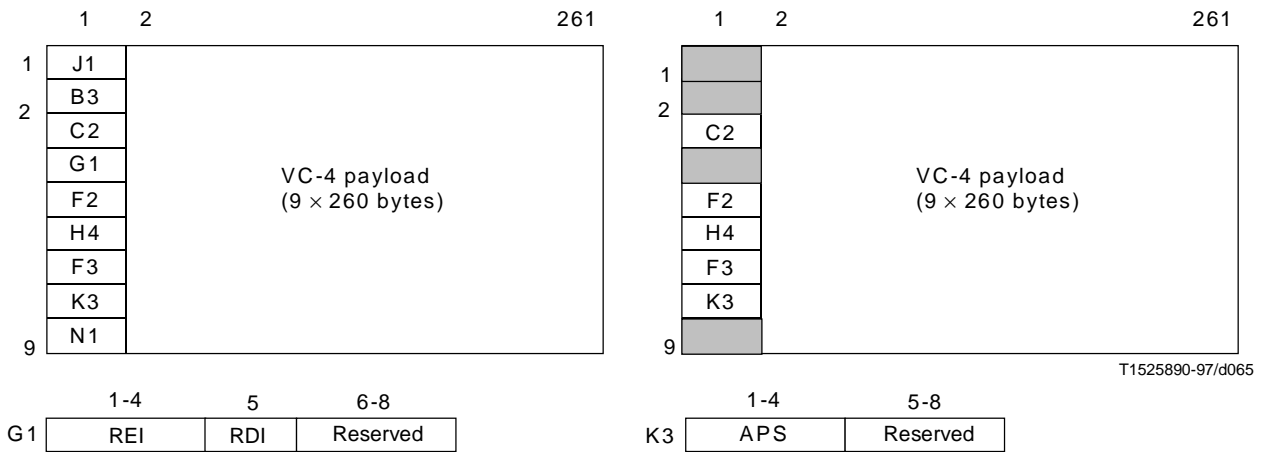

Figure 6-5/G.783 – S4_CI_D (left) and S4_AI_D (right)

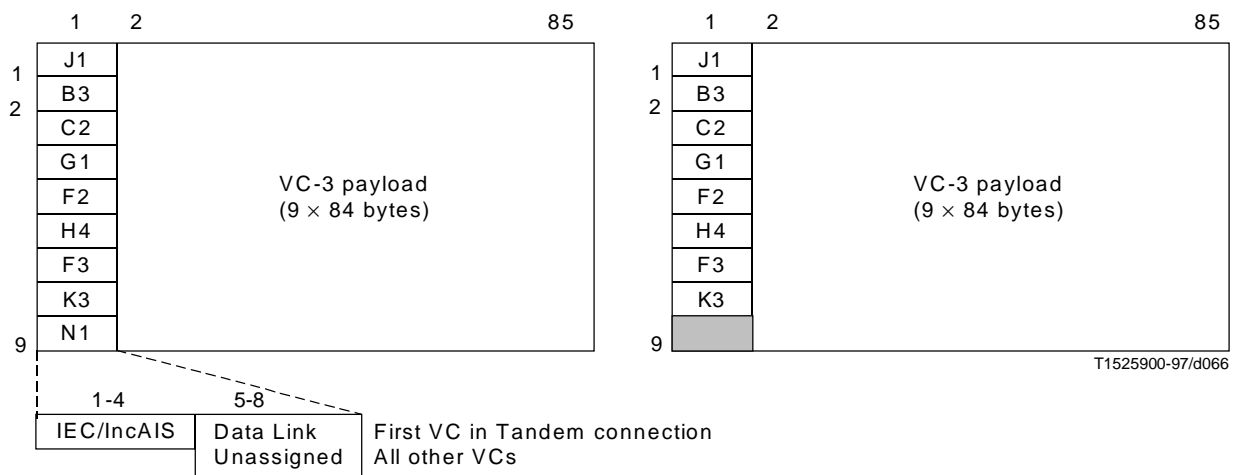

Figure 6-6/G.783 – S3_CI_D (left) with defined N1 and S3T_AI_D (right)

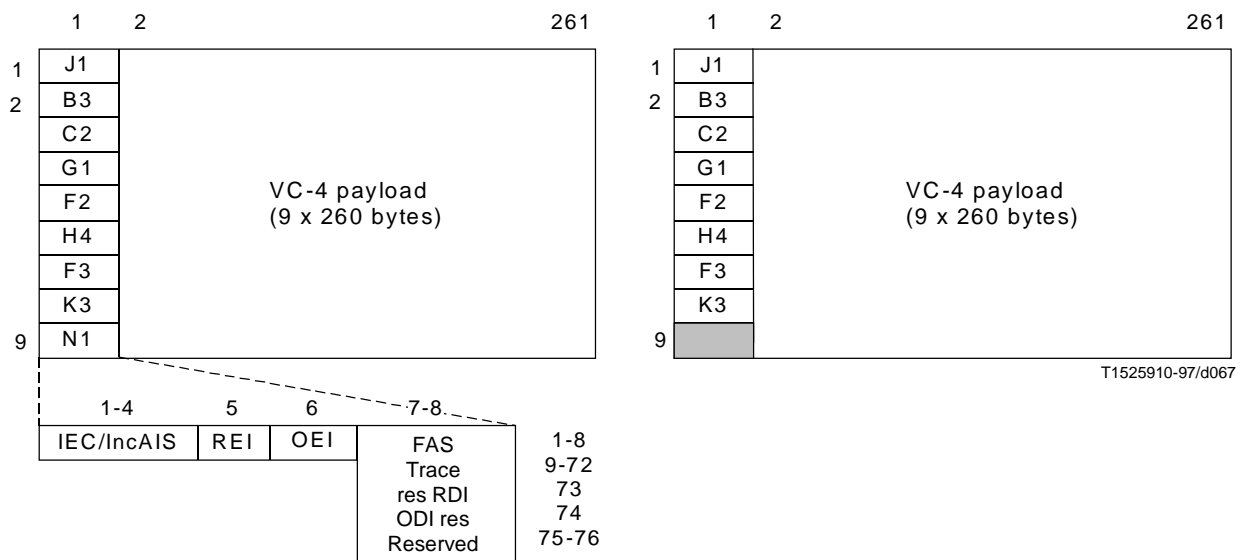

Figure 6-7/G.783 – S4_CI_D (left) with defined N1 and S4D_AI_D (right)

Layer functions

- Sn_C Higher order path connection function
- Sn_TT Higher order path trail termination function
- Snm_TT Higher order non-intrusive monitor function
- Sns_TT Higher order supervisory-unequipped termination function
- Sn/Sm_A Higher order path adaptation functions
- SnP_C Higher order path protection connection function
- SnP_TT Higher order path protection trail termination function
- Sn/SnP_A Higher order path protection adaptation function
- Sn/User_A Higher order path user data adaptation function
- Sn/Pqx_A Higher order trail adaptation function
- SnD_TT Higher order tandem connection (option 2) termination function

<i>SnD/Sn_A</i>	Higher order tandem connection (option 2) adaptation function
<i>SnDm_TT</i>	Higher order tandem connection (option 2) non-intrusive monitor function
<i>SnT_TT</i>	Higher order tandem connection (option 1) termination function
<i>SnT/Sn_A</i>	Higher order tandem connection (option 1) adaptation function
<i>SnTm_TT</i>	Higher order tandem connection (option 1) non-intrusive monitor function

Relationship to previous versions of Recommendation G.783

The 1994 version of Recommendation G.783 refers to the HPC, HPT, HPA, HUG and HPOM basic functions. Table 6-1 shows the relationship between these basic functions and the atomic functions in the Higher Order Path layers.

Table 6-1/G.783 – Higher order path layer basic and atomic functions

Basic function	Atomic function
HPT	<i>Sn_TT_So</i> <i>Sn_TT_Sk</i> <i>Sn/User_A_So</i> <i>Sn/User_A_Sk</i>
HPC	<i>Sn_C</i>
HPA	<i>Sn/Sm_A_So</i> <i>Sn/Sm_A_Sk</i>
HUG HPOM	<i>Sns_TT_So</i> <i>Sns_TT_Sk</i> <i>Snm_TT_Sk</i>

6.1 Connection Functions: *Sn_C*

6.1.1 Higher Order Trail Connection Function (*Sn_C*)

Sn_C is the function which assigns higher order VCs of level *n* (*n* = 3 or 4) at its input ports to higher order VCs of level *n* at its output ports.

The *Sn_C* connection process is an unidirectional function as illustrated in Figure 6-8. The signal formats at the input and output ports of the function are similar, differing only in the logical sequence of the VC-*ns*. As the process does not affect the nature of the characteristic information of the signal, the reference point on either side of the *Sn_C* function is the same, as illustrated in Figure 6-8.

Incoming VC-*ns* at the *Sn_CP* are assigned to available outgoing VC-*n* capacity at the *Sn_CP*.

An unequipped VC-*n* shall be applied at any outgoing VC-*n* which is not connected to an incoming VC-*n*.

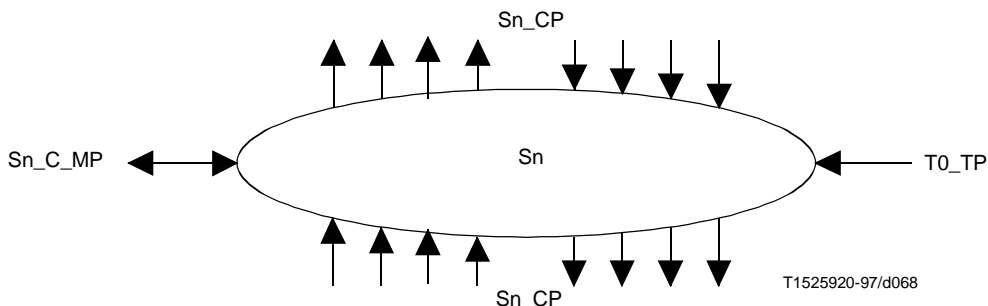

Figure 6-8/G.783 – General higher order trail connection function

Interfaces

See Table 6-2.

Table 6-2/G.783 – *Sn_C* input and output signals

Input(s)	Output(s)
Per <i>Sn_CP</i> , <i>n x</i> for the function: <i>Sn_CI_Data</i> <i>Sn_CI_Clock</i> <i>Sn_CI_FrameStart</i> <i>Sn_CI_SSF</i> <i>Sn_AI_TSF</i> <i>Sn_AI_TSD</i> 1 <i>x</i> per function: T0_TI_Clock T0_TI_FrameStart Per input and output connection point: <i>Sn_C_MI_ConnectionPortIds</i> Per matrix connection: <i>Sn_C_MI_ConnectionType</i> <i>Sn_C_MI_Directionality</i> Per SNC protection group: <i>Sn_C_MI_PROTtype</i> <i>Sn_C_MI_OPERtype</i> <i>Sn_C_MI_WTRtime</i> <i>Sn_C_MI_HOtime</i> <i>Sn_C_MI_EXTCMD</i>	Per <i>Sn_CP</i> , <i>m x</i> per function: <i>Sn_CI_Data</i> <i>Sn_CI_Clock</i> <i>Sn_CI_FrameStart</i> <i>Sn_CI_SSF</i> Per SNC protection group: <i>Sn_C_MI_pPSC</i> <i>Sn_C_MI_pPSSw</i> <i>Sn_C_MI_pPSSp</i> NOTE – protection status reporting signals are for further study.

Processes

In the *Sn_C* function VC-*n* Layer Characteristic Information is routed between input (termination) connection points [(T)CPs] and output (T)CPs by means of matrix connections. (T)CPs may be allocated within a protection group.

NOTE 1 – Neither the number of input/output signals to the connection function, nor the connectivity is specified in this Recommendation. That is a property of individual network elements. Examples of *Sn_C* are given in Appendix II.

Figure 6-1 presents a subset of the atomic functions that can be connected to this VC-*n* connection function: VC-*n* trail termination functions, VC-*m* non-intrusive monitor trail termination sink function, VC-*n* unequipped-supervisory trail termination functions, VC-*n* tandem connection trail termination and adaptation functions. In addition, adaptation functions in the VC-*n* server (e.g. MS1 or MS4) layers will be connected to this VC-*n* connection function.

Routing: The function shall be able to connect a specific input with a specific output by means of establishing a matrix connection between the specified input and output. It shall be able to remove an established matrix connection.

Each (matrix) connection in the *Sn_C* function should be characterized by the:

Type of connection:	Unprotected, 1 + 1 protected (SNC/I, SNC/N or SNC/S protection)
Traffic direction:	Unidirectional, bidirectional
Input and output connection points:	Set of connection point

NOTE 2 – Broadcast connections are handled as separate connections to the same input CP.

Provided no protection switching action is activated/required, the following changes to (the configuration of) a connection shall be possible without disturbing the CI passing the connection:

- addition and removal of protection;
- addition and removal of connections to/from a broadcast connection;
- change between operation types;
- change of WTR time;
- change of Hold-off time.

Unequipped VC generation: The function shall generate an unequipped VC-*n* signal, as specified in Recommendation G.707.

Defects

None.

Consequent actions

If an output of this function is not connected to one of its inputs, the function shall connect the unequipped VC-*n* [with valid frame start (FS) and SSF = false] to the output.

Defect correlation

None.

Performance monitoring

For each SNC protection group:

pPSC ← According to 2.2.5.6.

pPSSw ← According to 2.2.5.7.

pPSSp ← According to 2.2.5.7.

6.1.1.1 Higher order subnetwork connection protection process

Higher order subnetwork connection protection mechanism is described in Recommendation G.841.

Figure 6-9 gives the atomic functions involved in SNC protection. Bottom to the left is the two (working and protection) adaptation function (*MSn/Sn_A*) pairs. Above them is the non-intrusive monitoring functions (*Snm_TT_Sk*), in case of SNC/N they are not present. To the right is either the trail termination functions (*Sn_TT*) or the adaptation functions (*MSn/Sn_A*) depending on if the *Sn* trail is terminated at the same point the SNC protection is terminated or at a later point.

The *Sn_C* function may provide protection for the higher order trail against channel-associated defects within a higher order (sub)network connection.

The *Sn_C* functions at both ends operate the same way, by monitoring higher order subnetwork connection for defects, evaluating the system status taking into consideration the priorities of defect conditions and of external switch requests, and switching the appropriate channel to the protection (sub)network connection.

The signal flow associated with the *Sn_C* SNC protection process is described with reference to Figures 6-10 and 6-11. The *Sn_C* protection process receives control parameters and external switch requests at the *Sn_C_MP* reference point from the synchronous equipment management function and outputs status indicators at the *Sn_C_MP* reference point from the synchronous equipment management function, as a result of switch commands described in Recommendation G.841.

6.1.1.1.1 Source direction

Data at the *Sn_CP* is a higher order trail signal.

For 1 + 1 architecture, the signal received at the *Sn_CP* from the *MSn/Sn_A* (or *Sn_TT*) function is bridged permanently at the *Sn_CP* to both working and protection *MSn/Sn_A* functions.

NOTE – The atomic function connected at the *Sn_CP* to the *Sn_C* is either an *MSn/Sn_A* or an *Sn_TT*. When the higher order trail signal is terminated in this network element, it will be connected at the *Sn_CP* to an *Sn_TT*, otherwise it will be connected at the *Sn_CP* to an *MSn/Sn_A* (for further transport).

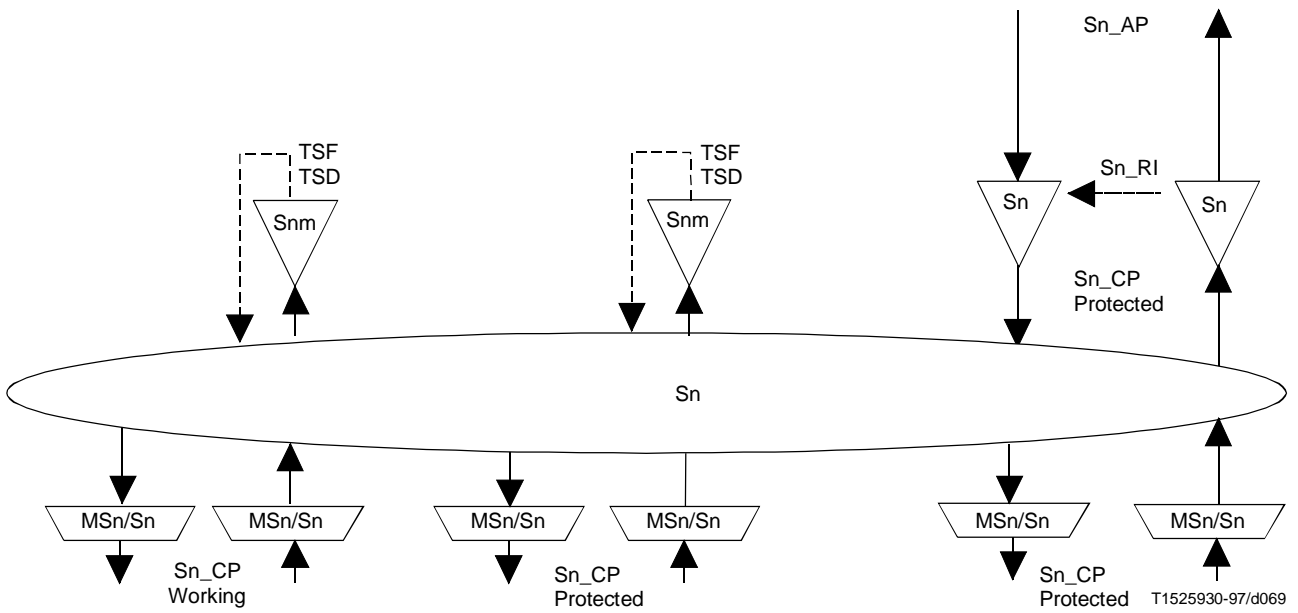

Figure 6-9/G.783 – Higher order SDH SNC/N protection atomic functions

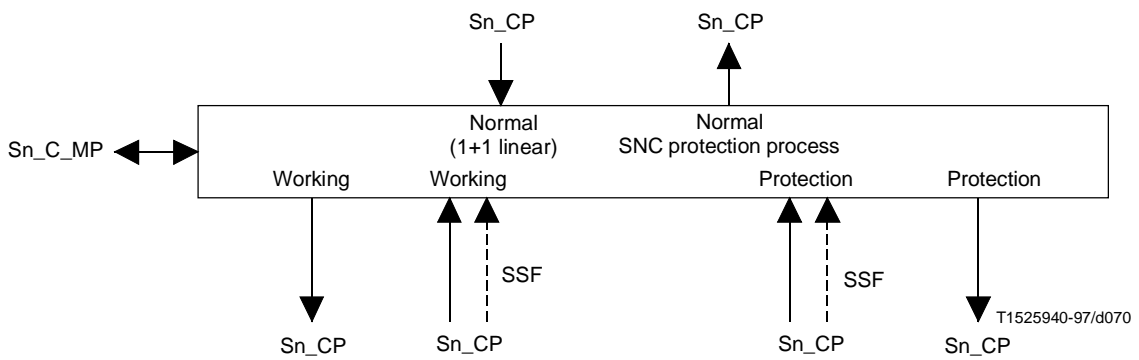

Figure 6-10/G.783 – Higher order inherent monitored subnetwork connection (SNC/I) protection process

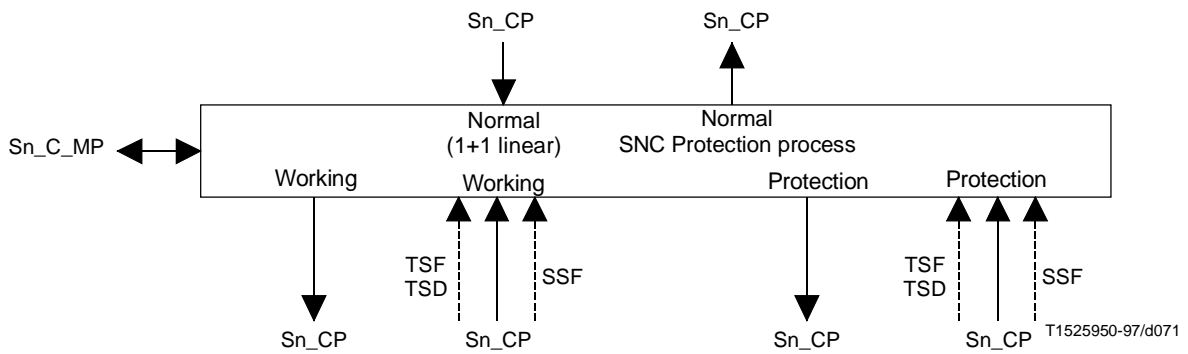

Figure 6-11/G.783 – Higher order non-intrusive monitored subnetwork connection (SNC/N) protection process

6.1.1.1.2 Sink direction

Framed higher order trail signals (data) are presented at the S_n_CP along with incoming timing references. The defect condition(s) SSF (and TSF and TSD) are also received at the S_n_CP from all MSn/Sn_A (or Snm_TT_Sk) functions.

For the SNC/I protection (Figures 6-9 and 6-10), the higher order trail signals pass the MSn/Sn_A functions. The SSF signals from the MSn/Sn_A_Sk are used by the S_n_C SNC protection process.

For SNC/N protection (Figures 6-9 and 6-11), the higher order trail signals are broadcasted to an Snm_TT_Sk function for non-intrusive monitoring of the higher order trail. The resultant TSF, TSD signals are used by the S_n_C SNC protection process instead of the SSF signal from the MSn/Sn_A .

Under normal conditions, S_n_C passes the data and timing from the working MSn/Sn_A functions to the MSn/Sn_A (or Sn_TT) function at the S_n_CP . The data and timing from the protection (sub)network connection is terminated.

If a switch is to be performed, then the data and timing received from the protection MSn/Sn_A at the S_n_CP is switched to the MSn/Sn_A (or Sn_TT) function at the SnP_C , and the signal received from the working MSn/Sn_A at the S_n_CP is not forwarded.

6.1.1.1.3 Switch initiation criteria

Automatic protection switching is based on the defect conditions of the working and protection (sub)network connections. These condition(s) are for SNC/I Server Signal Fail (SSF) and for SNC/N Trail Signal Fail (TSF) and Trail Signal Degrade (TSD). Detection of these conditions is described in 5.2 for MSn/Sn_A_Sk and 6.2.3 for Snm_TT_Sk .

The protection switch can also be initiated by switch commands received via the synchronous equipment management function. See the switch initiation criteria described in Recommendation G.841.

6.1.1.1.4 Switching time

Protection switching shall be completed within TBD ms of detection of an SSF, TSF or TSD condition that initiates a switch.

The protection switch completion time (T_{sw}) is for further study. A proposal is a basic switch time (T_{bs}) (after defect detection) of 100 ms increased by a provisionable holdoff time T_{ho} , with $0 \leq T_{ho} \leq 10$ s.

6.1.1.1.5 Switch restoration

In the revertive mode of operation, the working channel shall be restored, i.e. the signal on the protection (sub)network connection shall be switched back to the working (sub)network connection, when the working (sub)network connection has recovered from the fault.

To prevent frequent operation of the protection switch due to an intermittent fault, a failed (sub)network connection must become fault-free. After the failed (sub)network connection meets this criterion, a fixed period of time shall elapse before it is used again by a working channel. This period, called Wait to Restore (WTR) period should be of the order of 5-12 minutes and should be capable of being set. An SSF, TSF or TSD condition shall override the WTR.

6.2 Termination functions: Sn_TT , Snm_TT and Sns_TT

6.2.1 Higher order trail termination (Sn_TT)

The Higher order Path termination function comprises the atomic functions Higher order path trail termination source [Sn_TT_So , $n = (3 \text{ or } 4)$] and sink [Sn_TT_Sk , $n = (3 \text{ or } 4)$] as illustrated in Figure 6-12 and Tables 6-3 and 6-4.

The S_n_TT source function creates a VC- n ($n = 3$ or 4) at the S_n_CP by generating and adding POH to a container C- n from the S_n_AP . In the other direction of transmission it terminates and processes the POH to determine the status of the defined path attributes. The POH formats are defined in Recommendation G.707. The information flows associated with the S_n_TT functions are described in Figure 6-12 and Tables 6-3 and 6-4.

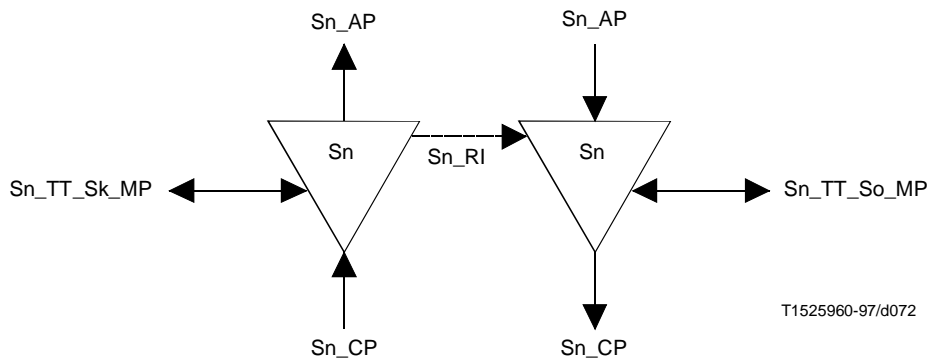

Figure 6-12/G.783 – Higher order trail termination function

Referring to Figure 6-12, data at the S_n_AP takes the form of a container C- n ($n = 3$ or 4) which is synchronized to the timing reference $T0_TP$.

Synchronously adapted information in the form of synchronous containers (data) and the associated container frame offset information (frame offset) are received at the S_n_AP .

6.2.1.1 Source direction

This function adds error monitoring and status overhead bytes to the S_n_AP .

Data at the S_n_AP is a VC- n ($n = 3, 4$), having a payload as described in Recommendation G.707, but with indeterminate VC-3/4 POH bytes: J1, B3, G1. These POH bytes are set as part of the S_n_TT function and the complete VC- n is forwarded to the S_n_CP .

Interfaces

Table 6-3/G.783 – $S_n_TT_So$ input and output signals

Input(s)	Output(s)
$S_n_AI_Data$ $S_n_AI_Clock$ $S_n_AI_FrameStart$ $S_n_RI_RDI$ $S_n_RI_REI$ $S_n_TT_So_MI_TxTI$	$S_n_CI_Data$ $S_n_CI_Clock$ $S_n_CI_FrameStart$

Processes

J1: The trail trace identifier should be generated. Its value is derived from reference point $S_n_TT_So_MP$. The path trace format is described in 2.2.2.4.

B3: Bit interleaved parity (BIP-8) is computed over all bits of the previous VC- n and placed in B3 byte position.

G1[1-4]: The number of errors indicated in RI_REI is encoded in the REI (bits 1 to 4 of the G1 byte).

G1[5]: When there is an active RI_RDI, the RDI indication shall be sent in bit 5 of the G1 byte within 250 μ s. Upon termination of the above conditions, the RDI indication shall be removed within 250 μ s.

Defects

None.

Consequent actions

None.

Defect correlation

None.

Performance monitoring

None.

6.2.1.2 Sink direction

This function monitors the lower order VC-*n* [*n* = (3 or 4)] for errors, and recovers the trail termination status. It extracts the payload independent overhead bytes/bits (J1, G1, B3) from the VC-*n* layer Characteristic Information.

Interfaces

Table 6-4/G.783 – *Sn_TT_Sk* input and output signals

Input(s)	Output(s)
<i>Sn_CI_Data</i> <i>Sn_CI_Clock</i> <i>Sn_CI_FrameStart</i> <i>Sn_CI_SSF</i> <i>Sn_TT_Sk_MI_TPmode</i> <i>Sn_TT_Sk_MI_ExTI</i> <i>Sn_TT_Sk_MI_RDI_Reported</i> <i>Sn_TT_Sk_MI_DEGTHR</i> <i>Sn_TT_Sk_MI_DEGM</i> <i>Sn_TT_Sk_MI_1second</i> <i>Sn_TT_Sk_MI_TIMdis</i>	<i>Sn_AI_Data</i> <i>Sn_AI_Clock</i> <i>Sn_AI_FrameStart</i> <i>Sn_AI_TSF</i> <i>Sn_AI_TSD</i> <i>Sn_RI_RDI</i> <i>Sn_RI_REI</i> <i>Sn_TT_Sk_MI_cTIM</i> <i>Sn_TT_Sk_MI_cUNEQ</i> <i>Sn_TT_Sk_MI_cEXC</i> <i>Sn_TT_Sk_MI_cDEG</i> <i>Sn_TT_Sk_MI_cRDI</i> <i>Sn_TT_Sk_MI_AcTI</i> <i>Sn_TT_Sk_MI_pN_EBC</i> <i>Sn_TT_Sk_MI_pF_EBC</i> <i>Sn_TT_Sk_MI_pN_DS</i> <i>Sn_TT_Sk_MI_pF_DS</i>

Processes

J1: The trail trace identifier is recovered from VC-*n* POH at the *Sn_CP* and processed as specified in 2.2.2.4. The accepted value of J1 is also available at the *Sn_TT_Sk_MP*. For further description of trace identifier mismatch processing, see 2.2.2.4.

C2: The unequipped defect is processed as described in 2.2.2.2.

B3: The error monitoring byte B3 at the *Sm_CP* shall be recovered. BIP-8 is computed for the VC-*n* frame. The computed BIP-8 value for the current frame is compared with the recovered B3 byte from the following frame. The process for detecting excessive errors and signal degrade is described in section 2.2.2.5.

G1[1-4]: The REI shall be recovered and the derived performance primitives should be reported at the $S_n_TT_Sk_MP$.

G1[5]: The RDI defect is processed as described in 2.2.2.6.

N1: The network operator byte N1 is defined for TC monitoring purposes. It shall be ignored by this function.

K3[5-8]: These bits are undefined and shall be ignored by this function.

Defects

The function shall detect for dUNEQ, dTIM, dEXC, dDEG and dRDI defects according to the specification in 2.2.2.

Consequent actions

The function shall perform the following consequent actions (see 2.2.3):

aAIS ← dUNEQ or dTIM
aRDI ← CI_SSF or dUNEQ or dTIM
aREI ← nN_B
aTSF ← CI_SSF or dUNEQ or dTIM
aTSFprot ← aTSF or dEXC
aTSD ← dDEG

On declaration of aAIS the function shall output an all-ONES (AIS) signal – complying to the frequency limits for this signal within 2 frames (250 microseconds). Upon termination of the above failure conditions the all-ONES shall be removed within two frames (250 microseconds).

Defect correlations

The function shall perform the following defect correlations to determine the most probable fault cause (see 2.2.4). This fault cause shall be reported to the SEMF.

cUNEQ ← dUNEQ and MON
cTIM ← dTIM and (not dUNEQ) and MON
cEXC ← dEXC and (not dTIM) and MON
cDEG ← dDEG and (not dTIM) and MON
cRDI ← dRDI and (not dUNEQ) and (not dTIM) and MON and RDI_Reported

Performance monitoring

The function shall perform the following performance monitoring primitives processing (see 2.2.5). The performance monitoring primitives shall be reported to the SEMF.

pN_DS ← aTSF or dEQ
pF_DS ← dRDI
pN_EBC ← $\sum nN_B$
pF_EBC ← $\sum nF_B$

6.2.2 Higher order non-intrusive monitor (S_{nm_TT})

The Higher order Path overhead monitor function comprises the atomic function Higher order non-intrusive monitor sink [$S_{nm_TT_Sk}$, $n = (3 \text{ or } 4)$] illustrated in Figure 6.13 and Table 6-5.

The S_n_TT function processes the POH to determine the status of the defined path attributes. The POH formats are defined in Recommendation G.707. The information flows associated with the S_{nm_TT} function are described in Figure 6-13 and Table 6-5.

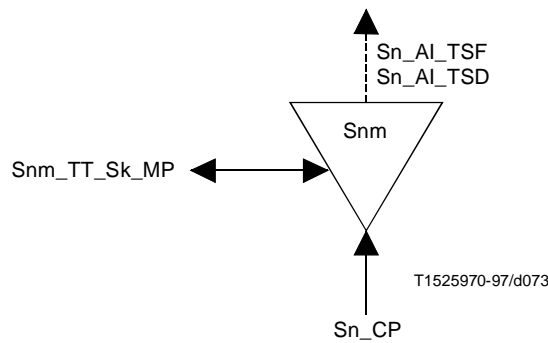

Figure 6-13/G.783 – Higher order path overhead monitor

6.2.2.1 Sink direction

This function monitors the higher order VC-*n* [*n* = (3 or 4)] for errors, and recovers the trail termination status. It extracts the payload independent overhead bytes/bits (J1, G1, B3) from the VC-*n* layer Characteristic Information.

Interfaces

Table 6-5/G.783 – Snm_TT_Sk input and output signals

Input(s)	Output(s)
<i>Sn_CI_Data</i> <i>Sn_CI_Clock</i> <i>Sn_CI_FrameStart</i> <i>Sn_CI_SSF</i> <i>Snm_TT_Sk_MI_TPmode</i> <i>Snm_TT_Sk_MI_ExTI</i> <i>Snm_TT_Sk_MI_RDI_Reported</i> <i>Snm_TT_Sk_MI_DEGTHR</i> <i>Snm_TT_Sk_MI_DEGM</i> <i>Snm_TT_Sk_MI_1second</i> <i>Snm_TT_Sk_MI_TIMdis</i>	<i>Sn_AI_TSF</i> <i>Sn_AI_TSD</i> <i>Snm_TT_Sk_MI_cTIM</i> <i>Snm_TT_Sk_MI_cUNEQ</i> <i>Snm_TT_Sk_MI_cDEG</i> <i>Snm_TT_Sk_MI_cRDI</i> <i>Snm_TT_Sk_MI_cAIS</i> <i>Snm_TT_Sk_MI_AcTI</i> <i>Snm_TT_Sk_MI_pN_EBC</i> <i>Snm_TT_Sk_MI_pF_EBC</i> <i>Snm_TT_Sk_MI_pN_DS</i> <i>Snm_TT_Sk_MI_pF_DS</i>

Processes

J1: The trail trace identifier is recovered from VC-*n* POH at the *Sn_CP*. The accepted value of J1 is also available at the *Snm_TT_Sk_MP*. For a description of trace identifier mismatch processing, see 2.2.2.4.

C2: The signal label bits at the *Sn_CP* shall be recovered. For further description of unequipped defect processing, see 2.2.2.2. The function shall detect for an AIS VC (VC-AIS) condition by monitoring the VC PSL for code "1111 1111". For further description of VC-AIS defect processing, see 2.2.2.3.

B3: Byte B3 is recovered from the VC-*n* POH the *Sn_CP*. BIP-8 is computed for the VC-*n* frame. The computed BIP-8 value for the current frame is compared with the recovered B3 byte from the following frame. The process for detecting excessive errors and signal degrade is described in section 2.2.2.5.

G1[1-4]: The REI shall be recovered and the derived performance primitives should be reported at the *S_{nm}_TT_Sk_MP*.

G1[5]: The RDI defect is processed as described in 2.2.2.6.

Defects

The function shall detect for dUNEQ, dTIM, dEXC, dDEG, dAIS and dRDI defects according to the specification in 2.2.2.

Consequent actions

The function shall perform the following consequent actions (see 2.2.3):

aTSF ← CI_SSF or dAIS or dUNEQ or dTIM

aTSFprot ← dEXC or aTSF

aTSD ← dDEG

Defect correlations

The function shall perform the following defect correlations to determine the most probable fault cause (see 2.2.4). This fault cause shall be reported to the SEMF.

cAIS ← dAIS and MON and AIS_Reported

cUNEQ ← dUNEQ and MON

cTIM ← dTIM and (not dUNEQ) and MON

cEXC ← dEXC and (not dTIM) and MON

cDEG ← dDEG and (not dTIM) and MON

cRDI ← dRDI and (not dUNEQ) and (not dTIM) and MON and RDI_Reported

Performance monitoring

The function shall perform the following performance monitoring primitives processing (see 2.2.5). The performance monitoring primitives shall be reported to the SEMF.

pN_DS ← aTSF or dEQ

pF_DS ← dRDI

pN_EBC ← $\sum nN_B$

pF_EBC ← $\sum nF_B$

6.2.3 Higher order supervisory-unequipped termination (*Sns_TT*)

The Higher order Supervisory-unequipped function comprises the atomic functions Higher order Supervisory unequipped termination source [*Sns_TT_So*, *n* 3 or 4] and sink [*Sns_TT_Sk*, *n* = (3 or 4)] as illustrated in Figure 6-14 and Tables 6-6 and 6-7.

The *Snm_TT* function creates a VC-*n* at the *S_n_CP* by generating and adding POH to an undefined container C-*n*. In the other direction of transmission it terminates and processes the POH to determine the status of the defined path attributes. The POH formats are defined in Recommendation G.707. The information flows associated with the *Snm_TT* function are described in Figure 6-14 and Tables 6-6 and 6-7.

NOTE – The *Sns_TT* [*n* = (3 or 4)] function generates and monitors supervisory-unequipped signals.

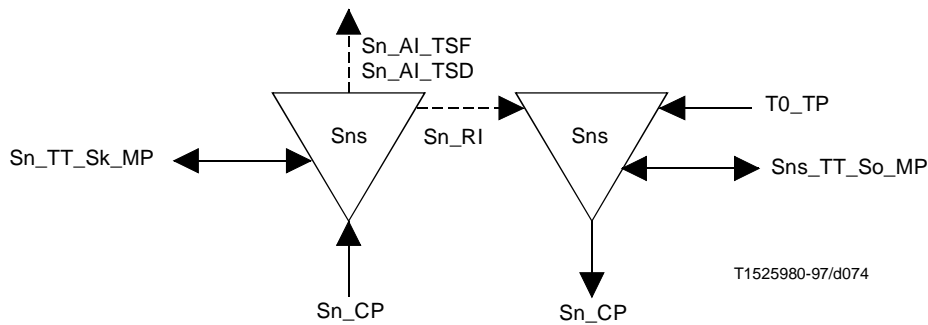

Figure 6-14/G.783 – Higher order supervisory unequipped termination function

6.2.3.1 Source direction

This function generates error monitoring and status overhead bytes to an undefined VC-*n* [*n* = (3 or 4)].

Interfaces

Table 6-6/G.783 – *Snm_So* input and output signals

Input(s)	Output(s)
<i>Sn_RI_RDI</i> <i>Sn_RI_REI</i> <i>T0_TI_Clock</i> <i>T0_TI_FrameStart</i> <i>Sns_TT_So_MI_TxTI</i>	<i>Sn_CI_Data</i> <i>Sn_CI_Clock</i> <i>Sn_CI_FrameStart</i>

Processes

An undefined VC-*n* [*n* = (3 or 4)] should be generated.

C2: Signal label 0000 0000 (unequipped) should be inserted in the VC-*n*.

J1: The trail trace identifier should be generated. Its value is derived from reference point *Sn_TT_So_MP*. The path trace format is described in 2.2.2.4.

B3: Bit interleaved parity (BIP-8) is computed over all bits of the previous VC-*n* and placed in B3 byte position.

G1[1-4]: The number of errors indicated in *RI_REI* is encoded in the *REI* (bits 1 to 4 of the G1 byte).

G1[5]: When there is an active *RI_RDI*, the *RDI* indication shall be sent in bit 5 of the G1 byte within 250 μs. Upon termination of the above conditions, the *RDI* indication shall be removed within 250 μs.

Defects

None.

Consequent actions

None.

Defect correlation

None.

Performance monitoring

None.

6.2.3.2 Sink Direction

Interfaces

Table 6-7/G.783 – Sns_TT_Sk input and output signals

Input(s)	Output(s)
<i>Sn_CI_Data</i> <i>Sn_CI_Clock</i> <i>Sn_CI_FrameStart</i> <i>Sn_CI_SSF</i> <i>Sns_TT_Sk_MI_TPmode</i> <i>Sns_TT_Sk_MI_ExTI</i> <i>Sns_TT_Sk_MI_RDI_Reported</i> <i>Sns_TT_Sk_MI_DEGTHR</i> <i>Sns_TT_Sk_MI_DEGM</i> <i>Sns_TT_Sk_MI_1second</i> <i>Sns_TT_Sk_MI_TIMdis</i>	<i>Sn_AI_TSF</i> <i>Sn_AI_TSD</i> <i>Sn_RI_RDI</i> <i>Sn_RI_REI</i> <i>Sns_TT_Sk_MI_cTIM</i> <i>Sns_TT_Sk_MI_cUNEQ</i> <i>Sns_TT_Sk_MI_cDEG</i> <i>Sns_TT_Sk_MI_cRDI</i> <i>Sns_TT_Sk_MI_AcTI</i> <i>Sns_TT_Sk_MI_pN_EBC</i> <i>Sns_TT_Sk_MI_pF_EBC</i> <i>Sns_TT_Sk_MI_pN_DS</i> <i>Sns_TT_Sk_MI_pF_DS</i>

Processes

J1: The trail trace identifier is recovered from VC-*n* POH at the *Sn_CP* and processed as specified in 2.2.2.4. The accepted value of J1 is also available at the *Sn_TT_Sk_MP*. For further description of trace identifier mismatch processing, see 2.2.2.4.

C2: The signal label at the *Sn_CP* shall be recovered. Note that the *Sns_TT* sink direction always expects an unequipped signal label. For further description of unequipped defect processing, see 2.2.2.2.

B3: The error monitoring byte B3 at the *Sm_CP* shall be recovered. BIP-8 is computed for the VC-*n* frame. The computed BIP-8 value for the current frame is compared with the recovered B3 byte from the following frame. The process for detecting excessive errors and signal degrade is described in section 2.2.2.5.

G1[1-4]: The REI shall be recovered and the derived performance primitives should be reported at the *Sns_TT_Sk_MP*.

G1[5]: The RDI defect is processed as described in 2.2.2.6.

Defects

The function shall detect for dUNEQ, dTIM, dEXC, dDEG and dRDI defects according to the specification in 2.2.2.

Consequent actions

The function shall perform the following consequent actions (see 2.2.3):

- aRDI ← SSF or dTIM
- aREI ← "number of error detection code violations"
- aTSF ← CI_SSF or dTIM
- aTSFprot ← aTSF or dEXC

Defect correlations

The function shall perform the following defect correlations to determine the most probable fault cause (see 2.2.4). This fault cause shall be reported to the SEMF.

- cUNEQ ← dTIM and (AcTI = all zeroes) and dUNEQ and MON
- cTIM ← dTIM and [not (dUNEQ and AcTI = all zeroes)] and MON
- cEXC ← dEXC and (not dTIM) and MON

cDEG ← dDEG and (not dTIM) and MON
 cRDI ← dRDI and (not dTIM) and MON and RDI_Reported

Performance monitoring

The function shall perform the following performance primitives processing (see 2.2.5). The performance monitoring primitives shall be reported to the SEMF.

pN_DS ← aTSF or dEQ
 pF_DS ← dRDI
 pN_EBC ← $\sum nN_B$
 pF_EBC ← $\sum nF_B$

6.3 Adaptation functions

6.3.1 Higher order trail adaptation function (Sn/Sm_A)

The Sn/Sm_A provides the primary functionality within the Sn/Sm_A, (m = 11, 12, 2 or 3; n = 3 or 4). It defines the TU pointer processing, and may be divided into three functions:

- pointer generation;
- pointer interpretation;
- frequency justification.

The format for TU pointers, their roles for processing, and mappings of VCs are described in Recommendation G.707.

Figure 6-15 illustrates the Sn/Sm_A function.

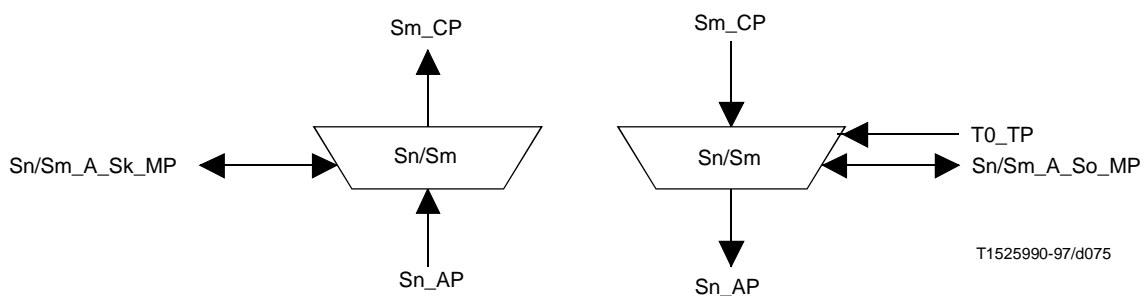

Figure 6-15/G.783 – Higher order path adaptation function

The Sn/Sm_A function also acts as a source and sink for bytes H4, and C2.

6.3.1.1 Source direction

Interfaces

See Table 6-8.

Table 6-8/G.783 – Sn/Sm_A_So input and output signals

Input(s)	Output(s)
<i>Sm</i> _CI_Data <i>Sm</i> _CI_Clock <i>Sm</i> _CI_FrameStart <i>Sm</i> _CI_MultiFrameSync Sn/Sm_A_So_MI_Active	Sn_AI_Data Sn_AI_Clock Sn_AI_FrameStart

Processes

The *Sn/Sm_A* function assembles VCs of lower order *m* (*m* = 11, 12, 2, 3) as TU-*m* into VCs of higher order *n* (*n* = 3 or 4).

The frame offset in bytes between a lower order VC and higher order VC is indicated by a TU pointer which is assigned to that particular lower order VC. The method of pointer generation is described in Recommendation G.707. LOVC data at the *Sm_CP* is synchronized to timing from the T0 reference point.

The PP function provides accommodation for wander and plesiochronous offset in the received signal with respect to the synchronous equipment timing reference. The PP function can be modelled as a data buffer which is being written with data, timed from the received VC clock, and read by a VC clock derived from reference point T0. When the write clock rate exceeds the read clock rate, the buffer gradually fills and vice versa. Upper and lower buffer occupancy thresholds determine when pointer adjustment should take place. The buffer is required to reduce the frequency of pointer adjustments in a network. The pointer hysteresis threshold spacing allocation is specified in 10.1.4.2. When the data in the buffer rise above the upper threshold for a particular VC, the associated frame offset is decremented by one byte and an extra byte is read from the buffer. When the data in the buffer fall below the lower threshold for a particular VC, the associated frame offset is incremented by one byte and the read opportunity is cancelled. Pointer processing in the *MSn/Sn_A* function is described in 5.3.1.

H4: A multiframe indicator is generated as described in Recommendation G.707 and placed in the H4 byte position.

C2: Signal label information derived directly from the Adaptation function type is placed in the C2 byte position.

Defects

None.

Consequent actions

The function shall perform the following consequent actions:

aAIS ← CI_SSF

When an all-ONES (AIS) signal is applied at the *Sm_CP*, an all-ONES (TU-AIS) signal shall be applied at the *Sn_AP* within 2 (multi)frames. Upon termination of the all-ONES signal at the *Sm_CP*, the all-ONES (TU-AIS) signal shall be terminated within 2 (multi)frames.

Defect correlation

None.

Performance monitoring

None.

6.3.1.2 Sink direction

Interfaces

See Table 6-9.

Table 6-9/G.783 – Sn/Sm_A_Sk input and output signals

Input(s)	Output(s)
<i>Sn_AI_Data</i> <i>Sn_AI_Clock</i> <i>Sn_AI_FrameStart</i> <i>Sn_AI_TSF</i>	<i>Sm_CI_Data</i> <i>Sm_CI_Clock</i> <i>Sm_CI_FrameStart</i> <i>Sm_CI_MFS</i> <i>Sm_CI_SSF</i>
<i>Sn/Sm_A_Sk_MI_Active</i>	<i>Sn/Sm_A_Sk_MI_cPLM</i> <i>Sn/Sm_A_Sk_MI_cLOM</i>

Processes

The S4/S_m_A_Sk function disassembles VC-4 into VCs of lower order m ($m = 11, 12, 2, 3$), performing multiframe alignment if necessary. S3/S_m_A_Sk disassembles VC-3 into VCs of lower order m ($m = 11, 12, 2$), performing multiframe alignment if necessary. The TU pointer of each lower order VC is decoded to provide information about the frame offset in bytes between the higher order VC and the individual lower order VCs. The method of pointer interpretation is described in Recommendation G.707. This process must allow for continuous pointer adjustments when the clock frequency of the node where the TU was assembled is different from the local clock reference. The frequency difference between these clocks affects the required size of the data buffer whose function is described below.

The function shall perform TU pointer interpretation as specified in Annex C to recover the LOVC frame phase within the HOVC. Two defect conditions can be detected by the pointer interpreter:

- Loss of Pointer (LOP);
- TU-AIS.

It should be noted that a persistent mismatch between provisioned and received TU type will result in a Loss of Pointer (LOP) defect.

C2: Byte C2 is recovered from VC- n port at the S_n_AP. If a dPLM is detected (see 2.2.2.7), then it shall be reported via reference point S_n/S_m_A_Sk_MP. The accepted value of C2 is also available at the S_n/S_m_A_Sk_MP.

NOTE 1 – Acceptance criteria and defect detection specification for signal label is for further study.

H4: In the case of payloads requiring multiframe alignment, a multiframe indicator is derived from the H4 byte (see 2.3.2). The received H4 value is compared to the next expected value in the multiframe sequence. The H4 value is assumed to be in phase when it is coincident with the expected value. If several H4 values are received consecutively not as expected but correctly in sequence with a different part of the multiframe sequence, then subsequent H4 values shall be expected to follow this new alignment. If several H4 values are received consecutively not correctly in sequence with any part of the multiframe sequence, then a Loss of Multiframe (LOM) event shall be reported at the S_n/S_m_A_Sk_MP. When several H4 values have been received consecutively correctly in sequence with part of the multiframe sequence, then the event shall be ceased and subsequent H4 values shall be expected to follow the new alignment.

NOTE 2 – The meaning of several is that the number should be low enough to avoid excessive delay in re-framing but high enough to avoid re-framing due to errors; a value in the range 2 to 10 is suggested.

Defects

The function shall detect for dAIS, dLOP, dLOM and dPLM defects according to the specification in 2.2.2.

Consequent actions

The function shall perform the following consequent actions (see 2.2.3):

For VC-3:

aAIS ← dPLM or dAIS or dLOP

aSSF ← dPLM or dAIS or dLOP

For VC-11/VC-12/VC-2:

aAIS ← dPLM or dLOM or dAIS or dLOP

aSSF ← dPLM or dLOM or dAIS or dLOP

Upon the declaration of aAIS, a logical all-ONEs (AIS) signal shall be applied at the S_m_CP within 2 (multi)frames. Upon termination of these aAIS, the all-ONEs signal shall be removed within 2 (multi)frames.

Defect correlations

The function shall perform the following defect correlations to determine the most probable fault cause (see 2.2.4). This fault cause shall be reported to the SEMF.

cPLM ← dPLM and (not TSF)

For VC-3:

cAIS ← dAIS and (not TSF) and (not dPLM) and AIS_Reported

cLOP ← dLOP and (not dPLM)

For VC-11/VC-12/VC-2:

cLOM ← dLOM and (not TSF) and (not dPLM)

cAIS ← dAIS and (not TSF) and (not dPLM) and (not dLOM) and AIS_Reported

cLOP ← dLOP and (not dPLM) and (not dLOM)

Performance monitoring

None.

6.3.2 Higher order trail adaptation function (Sn/Pqx_A)

Sn/Pqx_A [n = (3 or 4), q = (31, 32 or 4)] operates at the access port to a synchronous network or subnetwork and adapts user data for transport in the synchronous domain. Sn/Pqx_A function acts also as a source and sink for the POH payload dependent information. The Sn/Pqx_A function directly maps G.703 (PDH) signals into a higher order container. The information flows associated with the higher order adaptation function are shown in Figure 6-16 and Tables 6-11 and 6-12.

The higher order path adaptation function comprises the atomic functions higher order path adaptation source and sink.

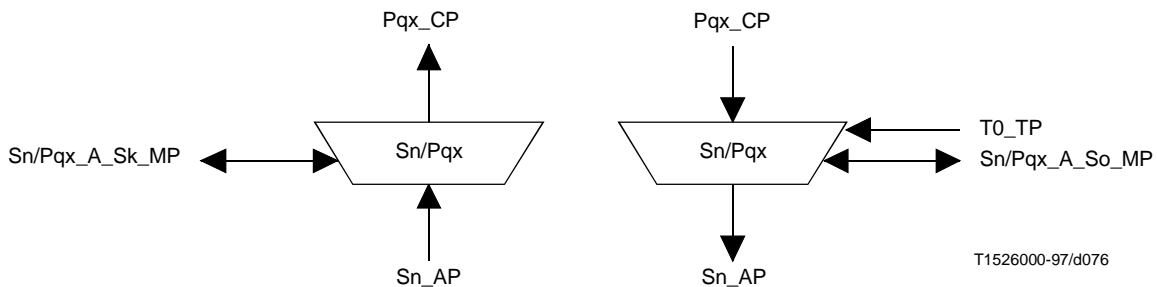

Figure 6-16/G.783 – Higher order path adaptation function

Adaptation functions are defined for each of the levels in the existing plesiochronous hierarchies. Each adaptation function defines the manner in which a user signal can be mapped into one of a range of synchronous containers C-m of appropriate size. The container sizes have been chosen for ease of mapping various combinations of sizes into high order containers; see Table 6.10. Detailed specifications for mapping user data into containers are given in Recommendation G.707.

Table 6-10/G.783 – – Container sizes

Atomic function	Server layer	Client layer	Signal label	Container size	HPA-n
S3/P31x_A	S3	P31x	0000 0100	C-3	HPA-3 async.
S3/P32x_A	S3	P32x	0000 0100	C-3	HPA-3 async.
S4/P4x_A	S4	P4x	0001 0010	C-4	HPA-4 async.

6.3.2.1 Source direction

Interfaces

Table 6-11 – Sn/Pqx_A_So input and output signals

Input(s)	Output(s)
Pqx_CI_Data Pqx_CI_Clock T0_TI_Clock T0_TI_FrameStart Sn/Pqx_A_So_MI_Active	Sn_AI_Data Sn_AI_Clock Sn_AI_FrameStart

Processes

Data at the Pqx_CP is the user information stream. Timing of the data is also delivered as timing at the CP. Data is adapted according to one of the adaptation functions referred to above. This involves synchronization and mapping of the information stream into a container as described in Recommendation G.707 and adding of payload dependent functions.

The container is passed to the Sn_AP as data together with frame offset which represents the offset of the container frame with respect to reference point T0_TP. This frame offset is constrained by the requirements of the client layer; e.g. for SDH equipment, the timing of the client layer is specified in Recommendation G.813.

Mapping of overhead and maintenance information from byte synchronously mapped G.703 (PDH) signals is for further study.

C2: The signal label shall be inserted according to the type of mapping used by the adaptation function, see Table 6-10.

Defects

None.

Consequent actions

None.

Defect correlation

None.

Performance monitoring

None.

6.3.2.2 Sink direction

Interfaces

Table 6-12/G.783 – Sn/Pqx_A_Sk input and output signals

Input(s)	Output(s)
Sn_AI_Data Sn_AI_Clock Sn_AI_FrameStart Sn_AI_TSF Sn/Pqx_A_Sk_MI_Active	Pqx_CI_Data Pqx_CI_Clock Sn/Pqx_A_Sk_MI_cPLM Sn/Pqx_A_Sk_MI_AcSL

Processes

The information stream data at the Sn_AP is presented as a container together with frame offset. The user information stream is recovered from the container together with the associated clock suitable for tributary line timing and passed to the reference point Pqx_CP as data and timing. This involves de-mapping and desynchronizing as described in Recommendation G.707 and payload dependent information.

NOTE – Other signals may be required from *Sn_CP* to generate overhead and maintenance information for byte-synchronously mapped G.703 (PDH) signals. This is for further study.

C2: Signal label, byte C2 is recovered. For further description of signal label processing, see 2.2.2.7.

Defects

The function shall detect for dPLM defects according to the specification in 2.2.

Consequent actions

The function shall perform the following consequent actions:

aAIS ← AI_TSF or dPLM

aSSF ← AI_TSF or dPLM

When AIS is applied at the *Sn_AP*, or a dPLM defect is detected (mismatch between expected value of signal label and received value of signal label), the adaptation function shall generate an all-ONEs signal (AIS) in accordance with the relevant G.700-Series Recommendations.

NOTE – In the case of 45 Mbit/s interface, the AIS signal is defined in Recommendation M.20.

Defect correlation

The function shall perform the following defect correlation to determine the most probable fault cause. This fault cause shall be reported to the SEMF.

cPLM ← dPLM and (not AI_TSF)

Performance monitoring

None.

6.3.3 Sn/User_A

6.3.3.1 Source direction

Interfaces

See Table 6-13.

Table 6-13/G.783 – Sn/User_A_So function inputs and outputs

Input(s)	Output(s)
User_CI_Data User_CI_Clock	Sn_AI_Data

Processes

F2, F3: Two bytes per frame are allocated for user communication purposes. They are derived from reference point U5 and placed in the F2 and F3 byte positions.

Defects

None.

Consequent actions

None.

Defect correlations

None.

Performance monitoring

None.

6.3.3.2 Sink direction

Interfaces

See Table 6-14.

Table 6-14/G.783 – Sn/User_A_Sk function inputs and outputs

Input(s)	Output(s)
<i>Sn_AI_Data</i> <i>Sn_AI_Clock</i> <i>Sn_AI_FrameStart</i> <i>Sn_AI_TSF</i>	<i>User_CI_Data</i> <i>User_CI_Clock</i> <i>User_CI_SSF</i>

Processes

F2, F3: Two bytes per frame are allocated for user communication purposes. They are derived from the F2 and F3 bytes and passed via reference point U5 to the overhead access function.

Defects

None.

Consequent actions

aSSF ← AI_TSF

aAIS ← AI_TSF

On declaration of aAIS the function shall output an all-ONEs (AIS) signal – complying to the frequency limits for this signal (a bit rate in range 64 kbit/s ± 100 ppm) within 2 frames (250 microseconds). Upon termination of the above failure conditions the all-ONEs shall be removed within two frames (250 microseconds).

Defect correlations

None.

Performance monitoring

None.

6.4 Sublayer functions

6.4.1 Higher order path protection sublayer functions

Processes

Higher order VC trail protection mechanism is described in Recommendation G.841.

The *SnP_C* function provides protection for the higher order trail against channel-associated defects within a higher order trail from trail termination source to trail termination sink.

The *SnP_C* function provides protection for the higher order trail against channel-associated defects within a lower order trail from trail termination source to trail termination sink. In Figure 6-17 the higher order trail protection sublayer is given. The protection is performed in the sublayer connection function (*SnP_C*).

The *SnP_C* functions at both ends operate the same way, by monitoring VC-*n* [*n* = (3 or 4)] signals for defects, evaluating the system status taking into consideration the priorities of defect conditions and of external and remote switch requests, and selecting the signal from the appropriate path. The two *SnP_C* functions may communicate with each other via a bit-oriented protocol defined for the *SnP_C* characteristic information byte K3 in the POH of the protection path. This protocol is described in Recommendation G.841.

In Figure 6-18 the higher order path protection function is explained. The working and protection paths are at the bottom.

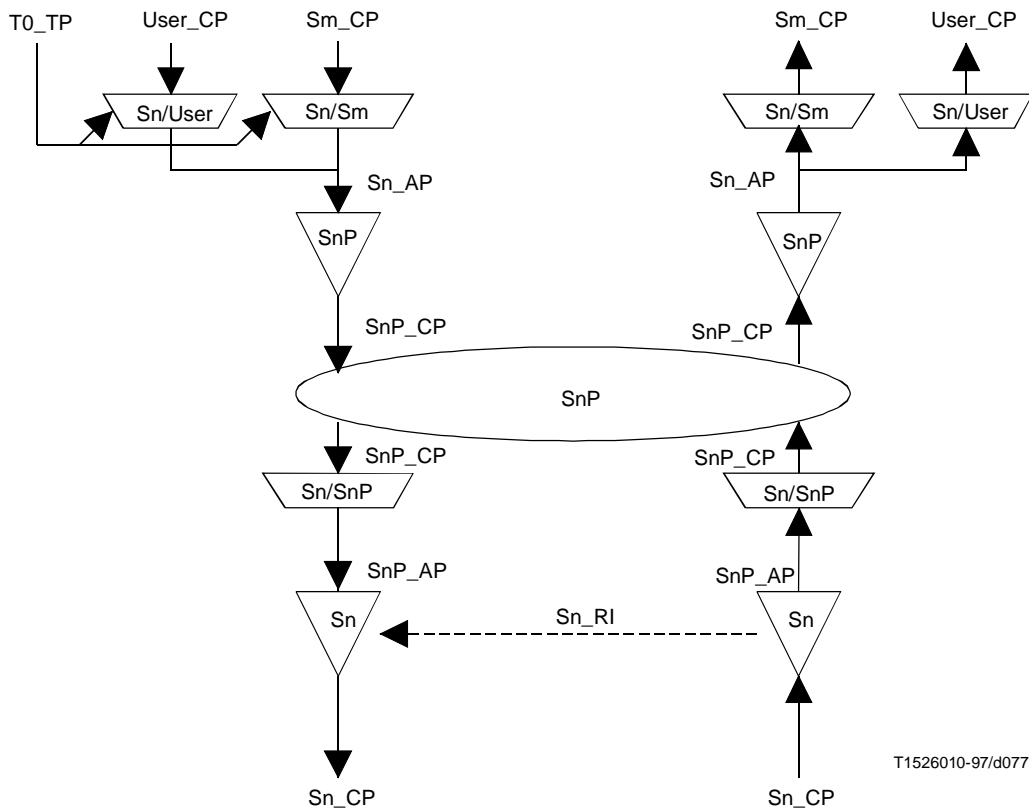

Figure 6-17/G.783 – Higher order path protection sublayer functions

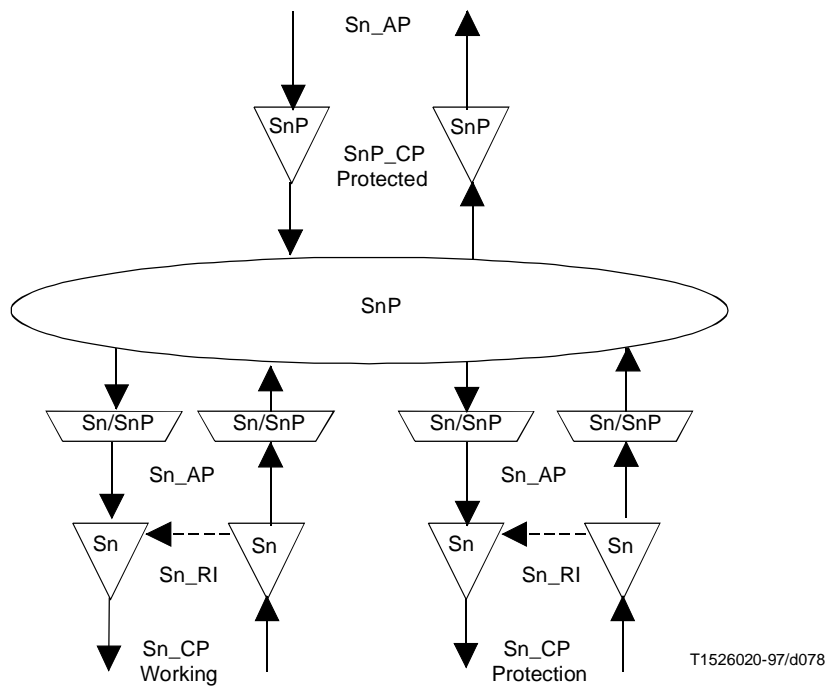

Figure 6-18/G.783 – Higher order path protection atomic functions

6.4.1.1 Higher order path protection connection function (SnP_C)

The signal flow associated with the SnP_C function is described with reference to Figure 6-19 and Table 6-15. The SnP_C function receives control parameters and external switch requests at the SnP_C_MP reference point from the synchronous equipment management function and outputs status indicators at the SnP_C_MP to the synchronous equipment management function, as a result of switch commands described in Recommendation G.841.

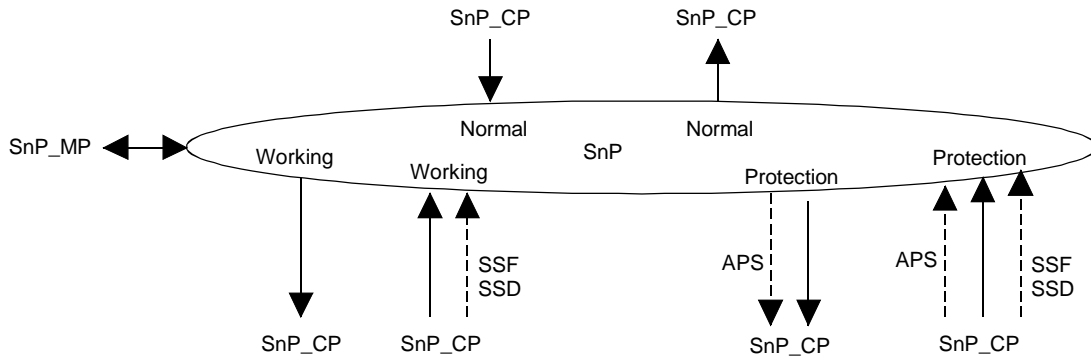

Figure 6-19/G.783 – Higher order path protection connection function

T1526030-97/d079

Interfaces

Table 6-15/G.783 – SnP_C input and output signals

<p>For connection points W and P: <i>Sn_AI_Data</i> <i>Sn_AI_Clock</i> <i>Sn_AI_FrameStart</i> <i>Sn_AI_SSF</i> <i>Sn_AI_SSD</i></p> <p>For connection point N: <i>Sn_AI_Data</i> <i>Sn_AI_Clock</i> <i>Sn_AI_FrameStart</i></p> <p>For connection point P: <i>Sn_AI_APS</i></p> <p><i>SnP_C_MI_OPERType</i> <i>SnP_C_MI_WTRTime</i> <i>SnP_C_MI_HOTime</i> <i>SnP_C_MI_EXTCMD</i></p>	<p>For connection points W and P: <i>Sn_AI_Data</i> <i>Sn_AI_Clock</i> <i>Sn_AI_FrameStart</i></p> <p>For connection point N: <i>Sn_AI_Data</i> <i>Sn_AI_Clock</i> <i>Sn_AI_FrameStart</i> <i>Sn_AI_SSF</i></p> <p>For connection point P: <i>Sn_AI_APS</i></p> <p><i>SnP_C_MI_pPSC</i> <i>SnP_C_MI_pPSSw</i> <i>SnP_C_MI_pPSSw</i></p> <p>NOTE – Protection status reporting signals are for further study.</p>
--	--

6.4.1.1.1 Source direction

Data at the Sn_CP is a higher order trail signal, timed from the T0_TP reference point, with indeterminate Sn layer POH bytes.

For 1 + 1 architecture, the signal received at the Sn_CP from the protection trail termination function SnP_TT_So is bridged permanently at the Sn_AP to both working and protection Sn_TT functions.

The APS information generated according to the rules in Recommendation G.841 is presented at the *SnP_CP* to the protection trail. This APS information may also be presented to the working trails Protection trail termination (*SnP_TT_So*) functions.

6.4.1.1.2 Sink direction

Framed Higher order trail signals (data) *SnP_CI* whose Higher order trail POH bytes have already been recovered by the *Sm_TT_Sk* are presented at the *Sn_CP* along with incoming timing references. The defect conditions SSF and SSD are also received at the *Sn_CP* from all *Sn_TT_Sk* functions.

The recovered APS information from the protection trail's adaptation function (*Sn/SnP_A_Sk*) is presented at the *SnP_CP*. Working trail's adaptation functions may also present this APS information to the *SnP_C*. The *SnP_C* must be able to ignore this information from the working adaptation functions.

Under normal conditions, *SnP_C* passes the data, timing, and signal fail from the working *Sn/SnP_A_Sk* functions to the corresponding *SnP_TT_Sk* at the *SnP_TCP*. The data, timing, and signal fail from the protection path is not forwarded.

Under a fault condition on the working path, *SnP_C* passes the data, timing, and signal fail from the protection *Sn/SnP_A_Sk* function to the corresponding *SnP_TT_Sk* at the *SnP_TCP*. The signal received from the working *Sn/SnP_A_Sk* is not forwarded.

6.4.1.1.3 Switch initiation criteria

Automatic protection switching is based on the TSF and TSD conditions of the working and protection paths. Detection of these conditions is described in 6.2.1.2.

The protection switch can also be initiated by switch commands received via the synchronous equipment management function. See Recommendation G.841.

6.4.1.1.4 Switching time

Protection switching shall be completed within TBD ms of detection of an SSF or SSD condition that initiates a switch.

The protection switch completion time is for further study. A proposal is a basic switch time T_{bs} of TBD ms increased by a holdoff time T_{ho} provisionable from 0 to 10 s in step of 100 ms.

6.4.1.1.5 Switch restoration

Switch restoration is a function related to revertive operation, when the working path has recovered from defect. It is not applicable to VC trail protection which supports non-revertive operation only. See the description of revertive 1 + 1 unidirectional protection switching in Recommendation G.841.

Defects

None.

Consequent actions

None.

Defect correlation

None.

Performance monitoring

pPSC ← According to 2.2.5.6.

pPSSw ← According to 2.2.5.7.

pPSSp ← According to 2.2.5.7.

6.4.1.2 Higher order path protection trail termination function (SnP_TT)

The Protection trail termination function comprises the atomic functions Protection trail termination source [SnP_TT_So, n = (3 or 4)] and sink [SnP_TT_Sk, n = (3 or 4)] as illustrated in Figure 6-20 and Table 6-16 and 6-17.

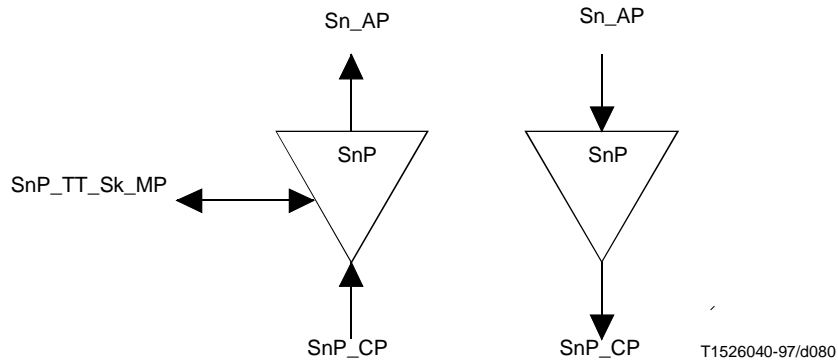

Figure 6-20/G.783 – Higher order path protection trail termination function

6.4.1.2.1 Source direction

Interfaces

Table 6-16/G.783 – SnP_TT_So input and output signals

Input(s)	Output(s)
SnP_AI_Data SnP_AI_Clock SnP_AI_FrameStart	SnP_CI_Data SnP_CI_Clock SnP_CI_FrameStart

Processes

No information processing is required in the SnP_TT_So since the Sn_AI at its output is identical to the SnP_CI.

Defects

None.

Consequent actions

None.

Defect correlation

None.

Performance monitoring

None.

6.4.1.2.2 Sink direction

Interfaces

Table 6-17/G.783 – SnP_TT_Sk input and output signals

Input(s)	Output(s)
<i>SnP_CI_Data</i> <i>SnP_CI_Clock</i> <i>SnP_CI_FrameStart</i> <i>SnP_CI_SSF</i>	<i>SnP_AI_Data</i> <i>SnP_AI_Clock</i> <i>SnP_AI_FrameStart</i> <i>SnP_AI_TSF</i> <i>SnP_TT_Sk_ML_cSSF</i>

Processes

The *SnP_TT_Sk* function report, as part of the *Sm* layer, the state of the protected *Sn* trail. In case all trails are unavailable, the *SnP_TT_Sk* reports the signal fail condition of the protected trail.

Defects

None.

Consequent actions

aTSF ← CI_SSF

Defect correlation

cSSF ← CI_SSF

Performance monitoring

None.

6.4.1.3 Higher order path protection adaptation function (Sn/SnP_A)

See Figure 6-21.

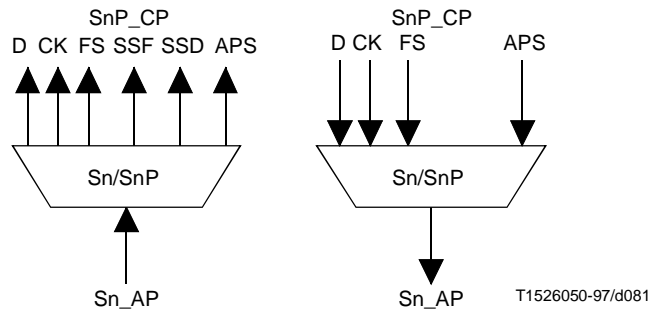

Figure 6-21/G.783 – Higher order path trail protection adaptation function

6.4.1.3.1 Source direction

Interfaces

See Table 6-18.

Table 6-18/G.783 – Sn/SnP_A_So input and output signals

Input(s)	Output(s)
<i>Sn_AI_Data</i> <i>Sn_AI_Clock</i> <i>Sn_AI_FrameStart</i> <i>Sn_AI_APS</i>	<i>Sn_AI_Data</i> <i>Sn_AI_Clock</i> <i>Sn_AI_FrameStart</i>

Processes

The function shall multiplex the *Sm* APS signal and *Sm* data signal onto the *Sn_AP*.

K3[1-4]: The insertion of the lower order APS signal is for further study. This process is required only for the protection trail.

Defects

None.

Consequent actions

None.

Defect correlation

None.

Performance monitoring

None.

6.4.1.3.2 Sink direction

Interfaces

See Table 6-19.

Table 6-19/G.783 – *SnP_A_Sk* input and output signals

Input(s)	Output(s)
<i>Sn_AI_Data</i> <i>Sn_AI_Clock</i> <i>Sn_AI_FrameStart</i> <i>Sn_AI_TSF</i> <i>Sn_AI_TSD</i>	<i>Sn_AI_Data</i> <i>Sn_AI_Clock</i> <i>Sn_AI_FrameStart</i> <i>Sn_AI_SSF</i> <i>Sn_AI_SSD</i> <i>Sn_AI_APS</i> (for Protection signal only)

Processes

The function shall extract and output the *SnP_CI_D* signal from the *SnP_AI_D* signal.

K3[1-4]: The extraction and persistency processing of the lower order APS signal is for further study. This process is required only for the protection trail.

Defects

None.

Consequent actions

aSSF ← AI_TSF

aSSD ← AI_TSD

Defect correlation

None.

Performance monitoring

None.

6.4.2 Option 2 tandem connection sublayer functions

Two options for higher order tandem connection monitoring are currently defined in Recommendation G.707, where they are referred to as "option 1" and "option 2". The functions defined in this subclause support option 2.

6.4.2.1 Higher order tandem connection trail termination function (SnD_TT)

This function acts as a source and sink for the higher order Tandem Connection OverHead (TCOH) described in Annex D/G.707 (TC monitoring protocol option 2). The information flows associated with the HTCT function are described with reference to Figure 6-22, Tables 6-20 and 6-21.

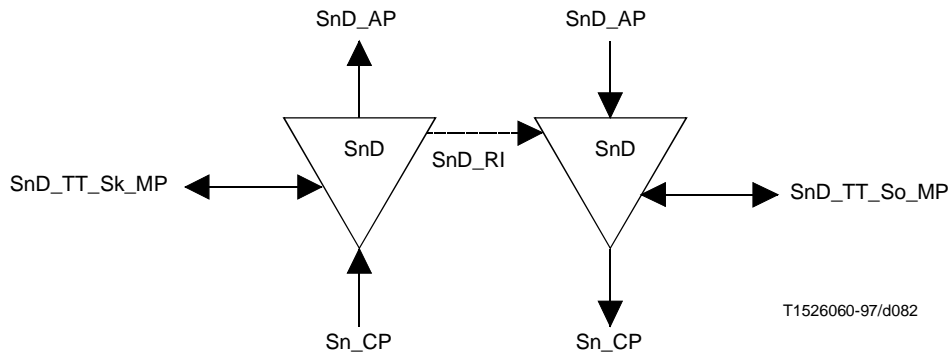

Figure 6-22/G.783 – Higher order tandem connection trail termination function

6.4.2.1.1 Source direction

Interfaces

Table 6-20/G.783 – SnD_TT_So input and output signals

Input(s)	Output(s)
<i>SnD_AI_Data</i> <i>SnD_AI_Clock</i> <i>SnD_AI_FrameStart</i> <i>SnD_AI_SF</i>	<i>Sn_CI_Data</i> <i>Sn_CI_Clock</i> <i>Sn_CI_FrameStart</i>
<i>SnD_RI_RDI</i> <i>SnD_RI_REI</i> <i>SnD_RI_ODI</i> <i>SnD_RI_OEI</i>	
<i>SnD_TT_So_MI_TxTI</i>	

Processes

N1[9][73]: The function shall insert the TC RDI code within 1 multiframe (9.5 ms) after the RDI request generation (RI_RDI) in sink direction. It ceases RDI code insertion within 1 multiframe (9.5 ms) after the RI_RDI request has cleared.

NOTE – N1[x][y] refers to bit x (x = 7,8) of byte N1 in frame y (y = 1..76) of the 76 frame multiframe.

N1[5]: The function shall insert the RI_REI value in the REI bit in the following frame.

N1[7][4]: The function shall insert the ODI code within 1 multiframe (9.5 ms) after the ODI request generation (RI_ODI) in the sink direction. It ceases ODI code insertion at the first opportunity after the RI_ODI request has cleared.

N1[6]: The function shall insert the RI_OEI value in the OEI bit in the following frame.

N1[7-8]: The function shall insert in the multiframed N1[7-8] channel:

- the Frame Alignment Signal (FAS) "1111 1111 1111 1110" in FAS bits in frames 1 to 8;
- the TC trace identifier, received via reference point HTCT_MP (SET Tx TC trace ID), in the TC trace ID bits in frames 9 to 72;

- the RDI (N1[8][73]) and ODI (N1[7][74]) signals; and
- all-0s in the six reserved bits in frames 73 to 76.

N1[1-4]: See 2.3.7.

B3: The function shall compensate the VC-*n* BIP-8 (in B3) according to the rule found in D.4/G.707, and as specified in 2.3.5.

Defects

None.

Consequent actions

None.

Defect correlation

None.

Performance monitor

None.

6.4.2.1.2 Sink direction

Interfaces

Table 6-21/G.783 – SnD_TT_Sk input and output signals

Input(s)	Output(s)
Sn_CI_Data Sn_CI_Clock Sn_CI_FrameStart Sn_CI_SSF SnD_TT_Sk_MI_ExTI SnD_TT_Sk_MI_RDI_Reported SnD_TT_Sk_MI_ODI_Reported SnD_TT_Sk_MI_TIMdis SnD_TT_Sk_MI_DEGM SnD_TT_Sk_MI_DEGTHR SnD_TT_Sk_MI_1second SnD_TT_Sk_MI_TPmode	SnD_AI_Data SnD_AI_Clock SnD_AI_FrameStart SnD_AI_TSF SnD_AI_TSD SnD_AI_OSF SnD_RI_RDI SnD_RI_REI SnD_RI_ODI SnD_RI_OEI SnD_TT_Sk_MI_cLTC SnD_TT_Sk_MI_cTIM SnD_TT_Sk_MI_cUNEQ SnD_TT_Sk_MI_cDEG SnD_TT_Sk_MI_cRDI SnD_TT_Sk_MI_cODI SnD_TT_Sk_MI_AcTI SnD_TT_Sk_MI_pN_EBC SnD_TT_Sk_MI_pF_EBC SnD_TT_Sk_MI_pN_DS SnD_TT_Sk_MI_pF_DS SnD_TT_Sk_MI_pON_EBC SnD_TT_Sk_MI_pOF_EBC SnD_TT_Sk_MI_pON_DS SnD_TT_Sk_MI_pOF_DS

Processes

TC EDC violations: See 2.3.6.

N1[1-4]: The function shall extract the Incoming Error Code (IEC). It shall accept the received code without further processing.

N1[7-8][9-72]: The Received Trail Trace Identifier shall be recovered from the tandem connection trail trace identifier overhead. The accepted value of TC trace identifier is also available at the HTCT_MP.

N1[1-4]: The function shall extract the Incoming AIS code.

N1[5], N1[8][73]: The information carried in the REI, RDI bits in byte N1 shall be extracted to enable single-ended maintenance of a bidirectional tandem connection Trail. The REI shall be used to monitor the error performance of the other direction of transmission, and the RDI shall be used to provide information as to the status of the remote receiver. A "1" indicates a Remote Defect Indication state, while a "0" indicates the normal, working state.

N1[6], M1[7][74]: The information carried in the OEI, ODI bits in byte N1 shall be extracted to enable single-ended (intermediate) maintenance of the VC-*n* egressing the tandem connection Trail. The OEI shall be used to monitor the error performance of the other direction of transmission, and the ODI shall be used to provide information as to the status of the remote receiver. A "1" indicates an Outgoing Defect Indication state, while a "0" indicates the normal, working state.

N1[7-8]: Multiframe alignment: see 2.3.4.

N1: The function shall terminate N1 channel by inserting an all-ZEROs pattern.

B3: The function shall compensate the VC-*n* BIP-8 in byte B3 according to the algorithm defined in the source direction.

Defects

The function shall detect for dUNEQ, dLTC, dTIM, dDEG, dRDI, dODI, IncAIS defects according to the specification in 2.2.2.

Consequent actions

The function shall perform the following consequent actions (see 2.2.3):

aAIS ← dUNEQ or dTIM or dLTC
aTSF ← CI_SSF or dUNEQ or dTIM or dLTC
aTSD ← dDEG
aRDI ← CI_SSF or dUNEQ or dTIM or dLTC
aREI ← N_B (errored TC-*m* block)
aODI ← CI_SSF or dUNEQ or dTIM or dIncAIS or dLTC
aOEI ← ON_B (errored outgoing VC-*m* block)
aOSF ← CI_SSF or dUNEQ or dTIM or dLTC or IncAIS

The function shall insert the all-ONEs (AIS) signal within 250 μs after AIS request generation, and cease the insertion within 250 μs after the AIS request is cleared.

Defect correlation

The function shall perform the following defect correlations to determine the most probable cause (see 2.2.4). This fault cause shall be reported to the SEMF.

cUNEQ ← dUNEQ
cLTC ← (not dUNEQ) and dLTC
cTIM ← (not dUNEQ) and (not dLTC) and dTIM
cDEG ← (not dTIM) and (not dLTC) and dDEG
cRDI ← (not dUNEQ) and (not dTIM) and (not dLTC) and dRDI and RDI_Reported
cODI ← (not dUNEQ) and (not dTIM) and (not dLTC) and dODI and ODI_Reported

Performance monitoring

The function shall perform the following performance monitoring primitives processing (see 2.2.5). The performance monitoring primitives shall be reported to the SEMF.

$pN_DS \leftarrow aTSF \text{ or } dEQ$

$pF_DS \leftarrow dRDI$

$pN_EBC \leftarrow \sum nN_B$

$pF_EBC \leftarrow \sum nF_B$

$pON_DS \leftarrow aODI \text{ or } dEQ$

$pOF_DS \leftarrow dODI$

$pON_EBC \leftarrow \sum nON_B$

$pOF_EBC \leftarrow \sum nOF_B$

6.4.2.2 Higher order tandem connection non-intrusive monitor function (SnDm_TT)

This function acts as a non-intrusive monitor for the higher order Tandem Connection OverHead (TCOH) described in Annex D/G.707 (HOTC monitoring protocol option 2).

The information flows associated with the SnDm_TT_Sk function are described with reference to Figure 6-23 and Table 6-22.

The timing signal is provided from the SETS at the T0_TP reference point.

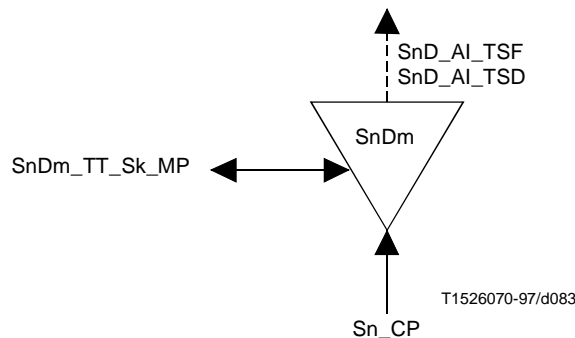

Figure 6-23/G.783 – Higher order tandem connection monitor function

This function can be used to perform the following:

- 1) single-ended maintenance of the TC by monitoring at an intermediate node, using remote information (RDI, REI);
- 2) aid in fault localization within TC trail by monitoring near-end defects;
- 3) monitoring of VC performance at TC egressing point (except for connectivity defects before the TC) using remote outgoing information (ODI, OEI);
- 4) performing non-intrusive monitor function within SNC/S protection.

Interfaces

Table 6-22/G.783 – SnDm_TT_Sk input and output signals

Input(s)	Output(s)
<i>Sn_CI_Data</i> <i>Sn_CI_Clock</i> <i>Sn_CI_FrameStart</i> <i>Sn_CI_SSF</i>	<i>SnD_AI_TSF</i> <i>SnD_AI_TSD</i>
<i>SnD_TT_Sk_MI_ExTI</i> <i>SnD_TT_Sk_MI_RDI_Reported</i> <i>SnD_TT_Sk_MI_ODI_Reported</i> <i>SnD_TT_Sk_MI_TIMdis</i> <i>SnD_TT_Sk_MI_DEGM</i> <i>SnD_TT_Sk_MI_DEGTHR</i> <i>SnD_TT_Sk_MI_1second</i> <i>SnD_TT_Sk_MI_TPmode</i>	<i>SnD_TT_Sk_MI_cLTC</i> <i>SnD_TT_Sk_MI_cTIM</i> <i>SnD_TT_Sk_MI_cUNEQ</i> <i>SnD_TT_Sk_MI_cDEG</i> <i>SnD_TT_Sk_MI_cRDI</i> <i>SnD_TT_Sk_MI_cODI</i> <i>SnD_TT_Sk_MI_AcTI</i> <i>SnD_TT_Sk_MI_pN_EBC</i> <i>SnD_TT_Sk_MI_pF_EBC</i> <i>SnD_TT_Sk_MI_pN_DS</i> <i>SnD_TT_Sk_MI_pF_DS</i> <i>SnD_TT_Sk_MI_pOF_EBC</i> <i>SnD_TT_Sk_MI_pOF_DS</i>

Processes

TC EDC violations: See 2.3.6.

N1[1-4]: The function shall extract the Incoming Error Code (IEC). It shall accept the received code without further processing.

N1[7-8][9-72]: The Received Trail Trace Identifier shall be recovered from the tandem connection trail trace identifier overhead. The accepted value of TC trace identifier is also available at the HTCMM_MP.

N1[1-4]: The function shall extract the Incoming AIS code.

N1[5], N1[8][73]: The information carried in the REI, RDI bits in byte N1 shall be extracted to enable single-ended maintenance of a bidirectional tandem connection Trail. The REI shall be used to monitor the error performance of the other direction of transmission, and the RDI shall be used to provide information as to the status of the remote receiver. A "1" indicates a Remote Defect Indication state, while a "0" indicates the normal, working state.

N1[6], N1[7][74]: The information carried in the OEI, ODI bits in byte N1 shall be extracted to enable single-ended (intermediate) maintenance of the HOVC egressing the tandem connection Trail. The OEI (nOF_B) shall be used to monitor the error performance of the other direction transmission, and the ODI shall be used to provide information as to the status of the remote receiver. A "1" indicates an Outgoing Defect Indication state, while a "0" indicates the normal, working state.

N1[7-8]: Multiframe alignment: See 2.3.4.

Defects

The function shall detect for dUNEQ, dLTC, dTIM, dDEG, dRDI, dODI, IncAIS defects according to the specification in 2.2.2.

Consequent actions

The function shall perform the following consequent actions (see 2.2.3):

aTSF ← CI_SSF or dUNEQ or dTIM or dLTC

aTSD ← dDEG

Defect correlation

The function shall perform the following defect correlations to determine the most probable cause (see 2.2.4). This fault cause shall be reported to the SEMF.

- cUNEQ ← dUNEQ
- cLTC ← (not dUNEQ) and dLTC
- cTIM ← (not dUNEQ) and (not dLTC) and dTIM
- cDEG ← (not dTIM) and (not dLTC) and dDEG
- cRDI ← (not dUNEQ) and (not dTIM) and (not dLTC) and dRDI and RDI_Reported
- cODI ← (not dUNEQ) and (not dTIM) and (not dLTC) and dODI and ODI_Reported

Performance monitoring

The function shall perform the following performance monitoring primitives processing (see 2.2.5). The performance monitoring primitives shall be reported to the SEMF.

- pN_DS ← aTSF or dEQ
- pF_DS ← dRDI
- pN_EBC ← $\sum nN_B$
- pF_EBC ← $\sum nF_B$
- pOF_DS ← dODI
- pOF_EBC ← $\sum nOF_B$

6.4.2.3 Higher order tandem connection adaptation function (SnD/Sn_A)

This function acts as a source and sink for the adaptation of HO Sn layer to HO SnD sublayer. This function is applicable for networks that support the higher order tandem connection monitoring protocol option 2 described in Annex D/G.707.

The information flows associated with the SnD/Sn_A function are described with reference to Figure 6-24 and Table 6-23.

The timing signal is provided from the SETS at the T0_TP reference point.

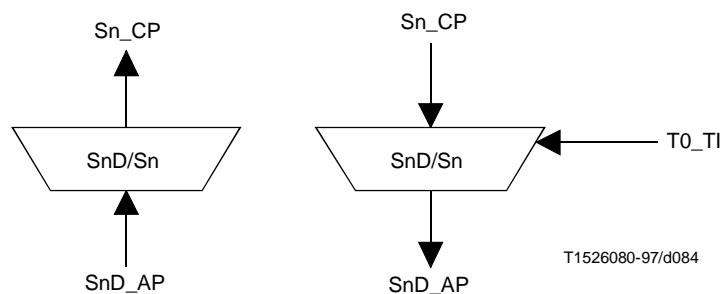

Figure 6-24/G.783 – Higher order tandem connection adaptation function

6.4.2.3.1 Source direction

Interfaces

Table 6-23/G.783 – SnD/Sn_A_So input and output signals

Input(s)	Output(s)
<i>Sn_CI_Data</i> <i>Sn_CI_Clock</i> <i>Sn_CI_FrameStart</i> <i>Sn_CI_SSF</i> <i>T0_TI_Ck</i>	<i>SnD_AI_Data</i> <i>SnD_AI_Clock</i> <i>SnD_AI_FrameStart</i> <i>SnD_AI_SF</i>

Processes

NOTE 1 – The function has no means to verify the existence of a tandem connection within the incoming signal. Nested tandem connections are not supported.

The function shall replace the incoming Frame Start signal by a local generated one (i.e. enter "holdover") if an all-ONEs (AIS) VC is received (i.e. this function replaces an all-ONEs incoming VC by a VC-AIS signal).

NOTE 2 – This replacement of the (invalid) incoming frame start signal results in the generation of a valid pointer in the MSn/Sn_A function.

Defects

None.

Consequent actions

This function shall perform the following consequent actions:

aSSF ← CI_SSF

Defect correlation:

None.

Performance monitoring:

None.

6.4.2.3.2 Sink direction

Interfaces

Table 6-24/G.783 – SnD/Sn_A_Sk input and output signals

Input(s)	Output(s)
<i>SnD_AI_Data</i> <i>SnD_AI_Clock</i> <i>SnD_AI_FrameStart</i> <i>SnD_AI_OSF</i>	<i>Sn_CI_Data</i> <i>Sn_CI_Clock</i> <i>Sn_CI_FrameStart</i> <i>Sn_CI_SSF</i>

Processes

The function shall restore the invalid frame start condition if that existed at the ingress of the tandem connection.

NOTE 3 – In addition, the invalid frame start condition is activated on a tandem connection connectivity defect condition that causes all-ONEs (AIS) insertion in the SnD_TT.

Defects

None.

Consequent actions

This function shall perform the following consequent actions:

AIS ← AI_OSF

aSSF ← AI_OSF

NOTE 4 – CI_SSF = true will result in AU-AIS generation by MSn/Sn_A function.

The function shall insert the all-ONES (AIS) signal within 250 μs after the AIS request has cleared.

Defect correlation

None.

Performance monitoring

None.

6.4.3 Option 1 tandem connection sublayer functions

Two options for higher order tandem connection monitoring are currently defined in Recommendation G.707, where they are referred to as "option 1" and "option 2". The functions defined in this subclause support option 1 for a single higher order VC-*n*.

6.4.3.1 Higher order tandem connection trail termination function (SnT_TT)

This function acts as a source and sink for the higher order Tandem Connection OverHead (TCOH) described in Annex C/G.707 (TC monitoring protocol option 1). The information flows associated with the HTCT function are described with reference to Figure 6-25, Tables 6-25 and 6-26.

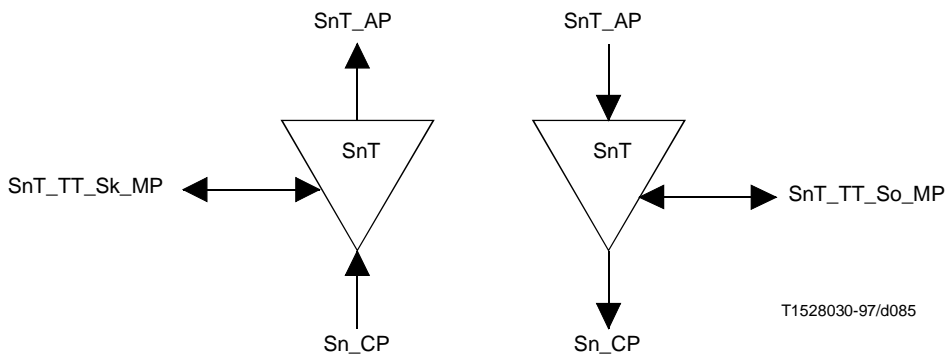

Figure 6-25/G.783 – Higher order tandem connection trail termination function

6.4.3.1.1 Source direction

Interfaces

Table 6-25/G.783 – SnT_TT_So input and output signals

Input(s)	Output(s)
SnT_AI_Data SnT_AI_Clock SnT_AI_FrameStart SnT_AI_SF	Sn_CI_Data Sn_CI_Clock Sn_CI_FrameStart

Processes

N1[1-4]: See 2.3.7.

B3: The function shall compensate the VC-*n* BIP-8 (in B3) according to the rule found in C.5/G.707 and as specified in 2.3.5.

Defects

None.

Consequent actions

None.

Defect correlation

None.

Performance monitoring

None.

6.4.3.1.2 Sink direction

Interfaces

Table 6-26/G.783 – SnT_TT_Sk input and output signals

Input(s)	Output(s)
<i>Sn_CI_Data</i> <i>Sn_CI_Clock</i> <i>Sn_CI_FrameStart</i> <i>Sn_CI_SSF</i> <i>SnT_TT_Sk_MI_DEGM</i> <i>SnT_TT_Sk_MI_DEGTHR</i> <i>SnT_TT_Sk_MI_1second</i> <i>SnT_TT_Sk_MI_TPmode</i>	<i>SnT_AI_Data</i> <i>SnT_AI_Clock</i> <i>SnT_AI_FrameStart</i> <i>SnT_AI_TSF</i> <i>SnT_AI_TSD</i> <i>SnT_AI_OSF</i> <i>SnT_TT_Sk_MI_cUNEQ</i> <i>SnT_TT_Sk_MI_cDEG</i> <i>SnT_TT_Sk_MI_pN_EBC</i> <i>SnT_TT_Sk_MI_pN_DS</i>

Processes

TC EDC violations: See 2.3.6.

N1[1-4]: The function shall extract the Incoming Error Code (IEC). It shall accept the received code without further processing.

N1[1-4]: The function shall extract the Incoming AIS code.

N1[1-4]: The function shall terminate N1[1-4] by inserting an all-ZEROs pattern.

Defects

The function shall detect for dUNEQ, dDEG, dIncAIS defects according to the specification in 2.2.2.

Consequent actions

The function shall perform the following consequent actions (see 2.2.3):

- aTSF ← CI_SSF
- aTSD ← dDEG
- aOSF ← CI_SSF or dIncAIS

The function shall insert the all-ONEs (AIS) signal within 250 μs after AIS request generation, and cease the insertion within 250 μs after the AIS request is cleared.

Defect correlation

The function shall perform the following defect correlations to determine the most probable cause (see 2.2.4). This fault cause shall be reported to the SEMF.

cUNEQ ← dUNEQ and MON

cDEG ← dDEG and MON

Performance monitoring

The function shall perform the following performance monitoring primitives processing (see 2.2.5). The performance monitoring primitives shall be reported to the SEMF.

pN_DS ← aTSF or dEQ

pN_EBC ← \sum nN_B

6.4.3.2 Higher order tandem connection non-intrusive monitor function (SnTm_TT)

This function acts as a non-intrusive monitor for the higher order Tandem Connection OverHead (TCOH) described in Annex C/G.707 (HOTC monitoring protocol option 1).

The information flows associated with the SnTm_TT_Sk function are described with reference to Figure 6-26 and Table 6-27.

The timing signal is provided from the SETS at the T0_TP reference point.

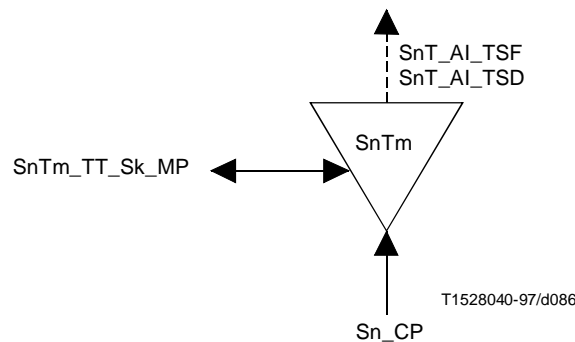

Figure 6-26/G.783 – Higher order tandem connection monitor function

This function can be used to aid in fault localization within a TC trail by monitoring near-end defects.

Interfaces

Table 6-27/G.783 – SnTm_TT_Sk input and output signals

Input(s)	Output(s)
Sn_CI_Data Sn_CI_Clock Sn_CI_FrameStart Sn_CI_SSF SnT_TT_Sk_MI_DEGM SnT_TT_Sk_MI_DEGTHR SnT_TT_Sk_MI_1second SnT_TT_Sk_MI_TPmode	SnT_AI_TSF SnT_AI_TSD SnT_TT_Sk_MI_cUNEQ SnT_TT_Sk_MI_cDEG SnT_TT_Sk_MI_pN_EBC SnT_TT_Sk_MI_pN_DS

Processes

TC EDC violations: See 2.3.6.

N1[1-4]: The function shall extract the Incoming Error Code (IEC). It shall accept the received code without further processing.

N1[1-4]: The function shall extract the Incoming AIS code.

Defects

The function shall detect for dUNEQ, dDEG, dIncAIS defects according to the specification in 2.2.2.

Consequent actions

The function shall perform the following consequent actions (see 2.2.3):

aTSF ← CI_SSF

aTSD ← dDEG

Defect correlation

The function shall perform the following defect correlations to determine the most probable cause (see 2.2.4). This fault cause shall be reported to the SEMF.

cUNEQ ← dUNEQ and MON

cDEG ← dDEG and MON

Performance monitoring

The function shall perform the following performance monitoring primitives processing (see 2.2.5). The performance monitoring primitives shall be reported to the SEMF.

pN_DS ← aTSF or dEQ

pN_EBC ← \sum nN_B

6.4.3.3 Higher order tandem connection adaptation function (SnT/Sn_A)

This function acts as a source and sink for the adaptation of HO Sn layer to HO SnT sublayer. This function is applicable for networks that support the higher order tandem connection monitoring protocol option 1 described in Annex C/G.707.

The information flows associated with the SnT/Sn_A function are described with reference to Figure 6-27, Tables 6-28 and 6-29.

The timing signal is provided from the SETS at the T0_TP reference point.

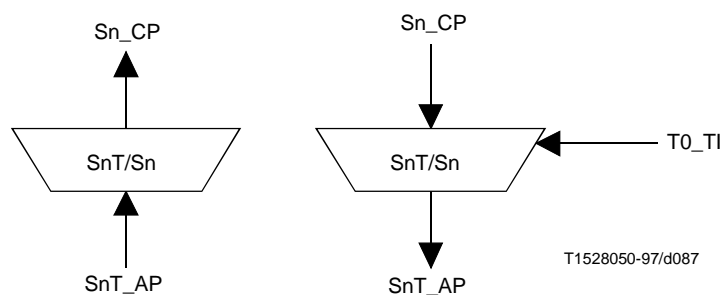

Figure 6-27/G.783 – Higher order tandem connection adaptation function

6.4.3.3.1 Source direction

Interfaces

Table 6-28/G.783 – SnT/Sn_A_So input and output signals

Input(s)	Output(s)
<i>Sn_CI_Data</i> <i>Sn_CI_Clock</i> <i>Sn_CI_FrameStart</i> <i>Sn_CI_SSF</i> <i>T0_TI_CK</i>	<i>SnT_AI_Data</i> <i>SnT_AI_Clock</i> <i>SnT_AI_FrameStart</i> <i>SnT_AI_SSF</i>

Processes

NOTE 1 – The function has no means to verify the existence of a tandem connection within the incoming signal. Nested tandem connections are not supported.

The function shall replace the incoming Frame Start signal by a local generated one (i.e. enter "holdover") if an all-ONEs (AIS) VC is received (i.e. this function replaces an all-ONEs incoming VC by a VC-AIS signal).

NOTE 2 – This replacement of the (invalid) incoming frame start signal results in the generation of a valid pointer in the MSn/Sn_A function.

Defects

None.

Consequent actions

This function shall perform the following consequent actions:

aSSF ← CI_SSF

Defect correlation

None.

Performance monitoring

None.

6.4.3.3.2 Sink direction

Interfaces

Table 6-29/G.783 – SnT/Sn_A_Sk input and output signals

Input(s)	Output(s)
<i>SnT_AI_Data</i> <i>SnT_AI_Clock</i> <i>SnT_AI_FrameStart</i> <i>SnT_AI_OSF</i>	<i>Sn_CI_Data</i> <i>Sn_CI_Clock</i> <i>Sn_CI_FrameStart</i> <i>Sn_CI_SSF</i>

Processes

The function shall restore the invalid frame start condition if that existed at the ingress of the tandem connection.

NOTE 1 – In addition, the invalid frame start condition is activated on a tandem connection connectivity defect condition that causes all-ONEs (AIS) insertion in the SnT_TT.

N1[5-8]: The function shall terminate N1[5-8] by inserting an all-ZEROs pattern.

B3: The function shall compensate the VC-*n* BIP-8 in byte B3 according to the algorithm specified in 2.3.5.

Defects

None.

Consequent actions

This function shall perform the following consequent actions:

aAIS ← AI_OSF

aSSF ← AI_OSF

NOTE 2 – CI_SSF = true will result in AU-AIS generation by MSn/Sn_A function.

The function shall insert the all-ONES (AIS) signal within 250 μs after AIS request generation, and cease the insertion within 250 μs after the AIS request is cleared.

Defect correlation

None.

Performance monitoring

None.

6.4.3.4 Tandem connection datalink adaptation function (SnT/DL_A)

The SnT/DL_A adaptation function is applicable for networks that support the higher order tandem connection monitoring option 1 data link (DL) as described in Annex C/G.707. The SnT/DL_A adaptation function places bits 5-8 of byte N1 of the TCOH into the SnT_AI in the source direction and recovers the information from SnT_AI in the sink direction. The information flows associated with the SnT/DL_A function are described with reference to Figures 6-28 and 6-29 and Tables 6-30 and 6-31.

6.4.3.4.1 Source direction

Symbol

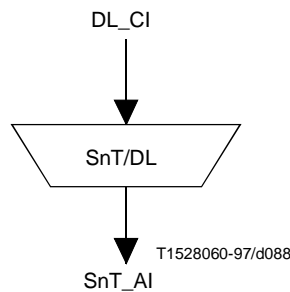

Figure 6-28/G.783 – SnT/DL_A_So function

Interfaces

Table 6-30/G.783 – SnT/DL_A_So function inputs and outputs

Inputs	Outputs
DL_CI_Data SnT_AI_FrameStart SnT_AI_Clock	SnT_AI_Data DL_CI_Clock

Processes

The Data Link (DL) bits are derived from the DL message communications function and placed in bits 5-8 of N1. The bits shall be used as described in Annex C/G.707. The data link is a message based channel to support tandem connection maintenance.

Defects

None.

Consequent actions

None.

Defect correlations

None.

Performance monitoring

None.

6.4.3.4.2 Sink direction

Symbol

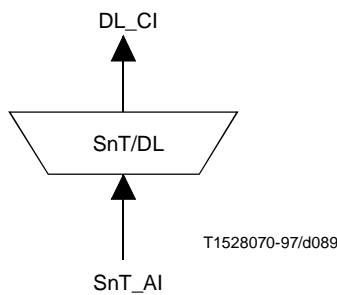

Figure 6-29/G.783 – SnT/DL_A_Sk function

Interfaces

Table 6-31/G.783 – SnT/DL_A_Sk function inputs and outputs

Inputs	Outputs
SnT_AI_Data SnT_AI_Clock SnT_AI_FrameStart SnT_AI_TSF	DL_CI_Data DL_CI_Clock DL_CI_SSF

Processes

The DL bits N1[5-8] are recovered from the TCOH and passed to the DL communications function.

Defects

None.

Consequent actions

aSSF ← AI_TSF

Defect correlations

None.

Performance monitoring

None.

6.4.3.5 Tandem connection data link adaptation function for non-intrusive monitoring (SnTm/DL_A)

This function acts as a non-intrusive monitor for the higher order tandem connection overhead Data Link (DL) described in Annex C/G.707 (option 1).

The information flows associated with the SnTm/DL_A function are described with reference to Figure 6-30 and Table 6-32.

6.4.3.5.1 Sink direction

Symbol

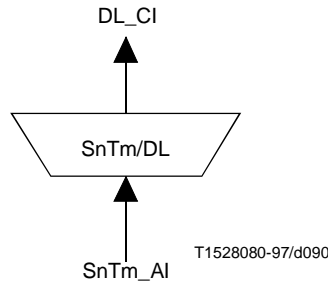

Figure 6-30/G.783 – SnTm/DL_A_Sk function

Interfaces

Table 6-32/G.783 – SnTm/DL_A_Sk function inputs and outputs

Inputs	Outputs
SnTm_AI_Data SnTm_AI_Clock SnTm_AI_FrameStart SnTm_AI_TSF	DL_CI_Data DL_CI_Clock DL_CI_SSF

Processes

The Data Link (DL) information from the bits 5-8 of N1 byte are recovered from the SnTm_AI and are passed to the DL communications function.

Defects

None.

Consequent actions

aSSF ← AI_TSF

Defect correlations

None.

Performance monitoring

None.

7 Lower order SDH path (Sm) layer

The lower order path layers are the VC-3, VC-2, VC-12 and VC-11 path layers. See Figure 7-1.

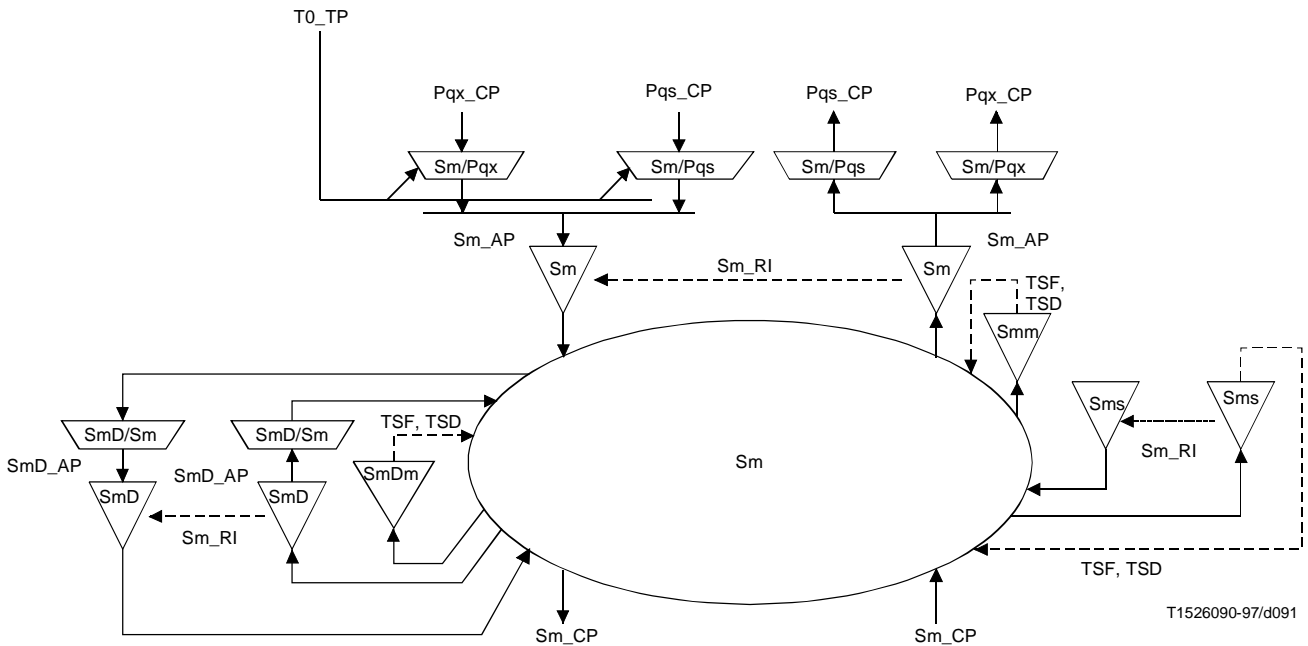

Figure 7-1/G.783 – Low order SDH path layer atomic functions

Lower order *Sm* layer characteristic information

The Characteristic Information *Sm_CI* has co-directional timing and is octet structured with a 125 μ s or 500 μ s frame, as shown in Figures 7-2 to 7-9, left frames. Its format is characterized as the VC-*m* [*m* = (11, 12, 2 or 3)] trail termination overhead in the V5 and J2 bytes or the J1, B3, and G1 bytes as defined in Recommendation G.707 plus the *Sm* Adapted Information given in the next section. Alternatively it may be an unequipped signal as defined in Recommendation G.707.

For the case of a signal within the tandem connection sublayer, the Characteristic Information has defined *Sm* tandem connection trail termination overhead in location N2 or N1 as shown in Figures 7-3, 7-5, 7-7 and 7-9.

Lower order *Sm* layer adaptation information

The Adaptation Information AI is octet structured with an 125 or 500 μ s frame as shown in Figures 7-2 to 7-9, right frames. In the S3_AI case, it represents adapted label, and client specific information combined with 1 byte user channels F2 and F3. For the case the signal has passed the trail protection sublayer (*SmP*), *Sm_AI* has defined APS bits (1 to 4) in byte K4 or K3.

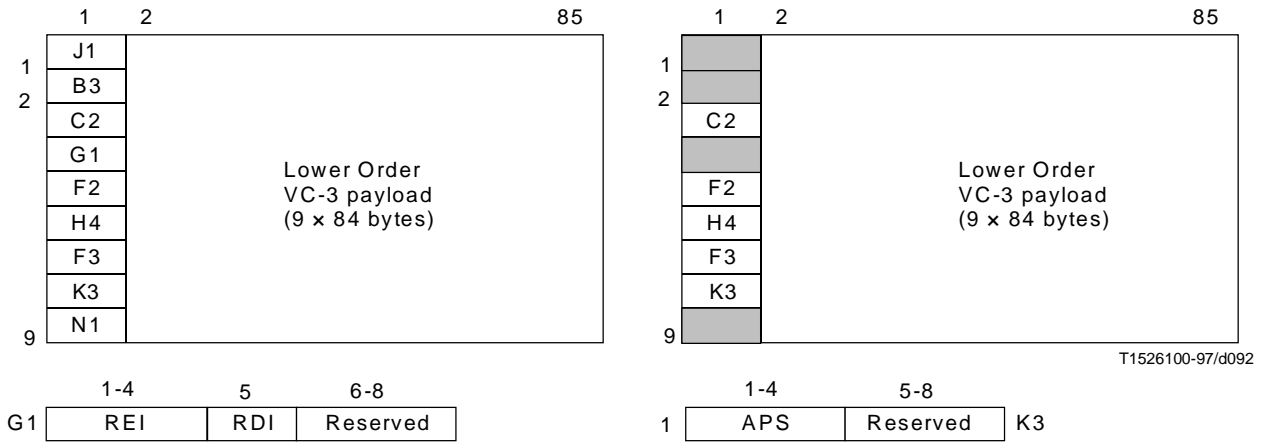

Figure 7-2/G.783 – S3_CI_D (left) and S3_AI_D (right)

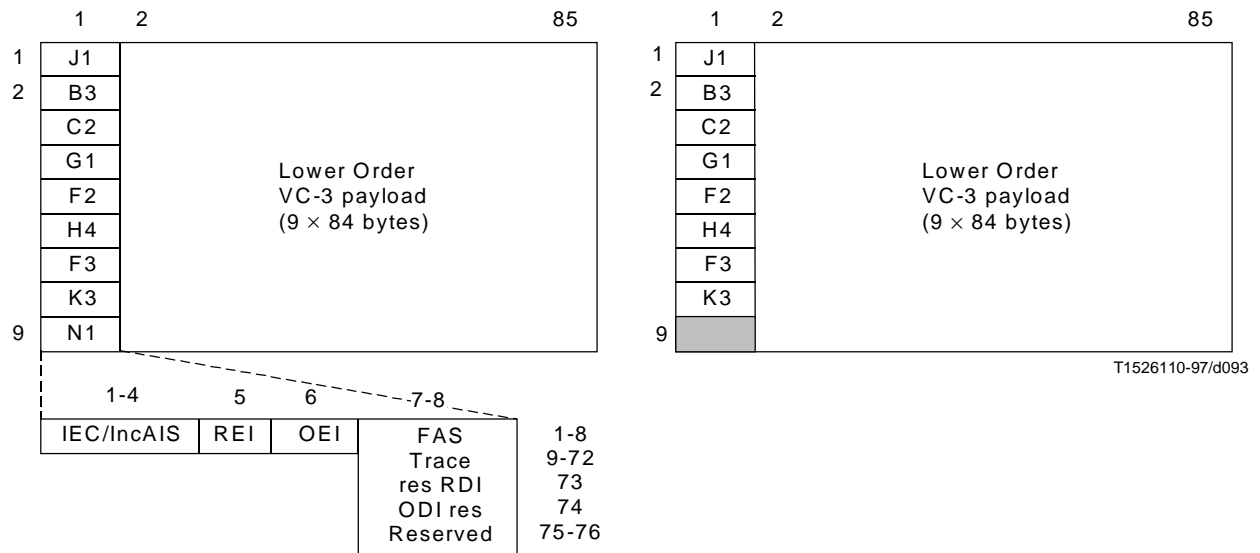

Figure 7-3/G.783 – S3_CI_D (left) with defined N1 and S3_AI_D (right)

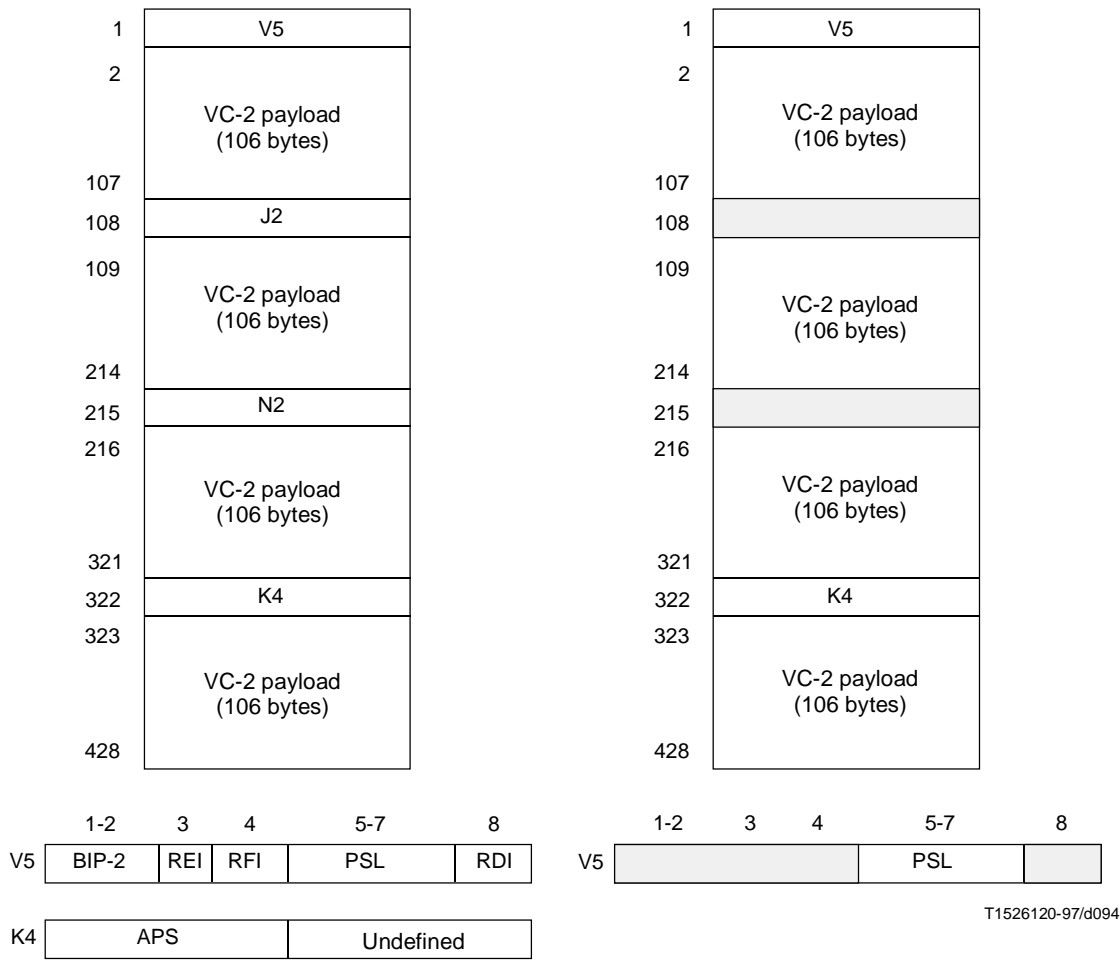

Figure 7-4/G.783 – S2_CI_D (left) and S2_AI_D (right)

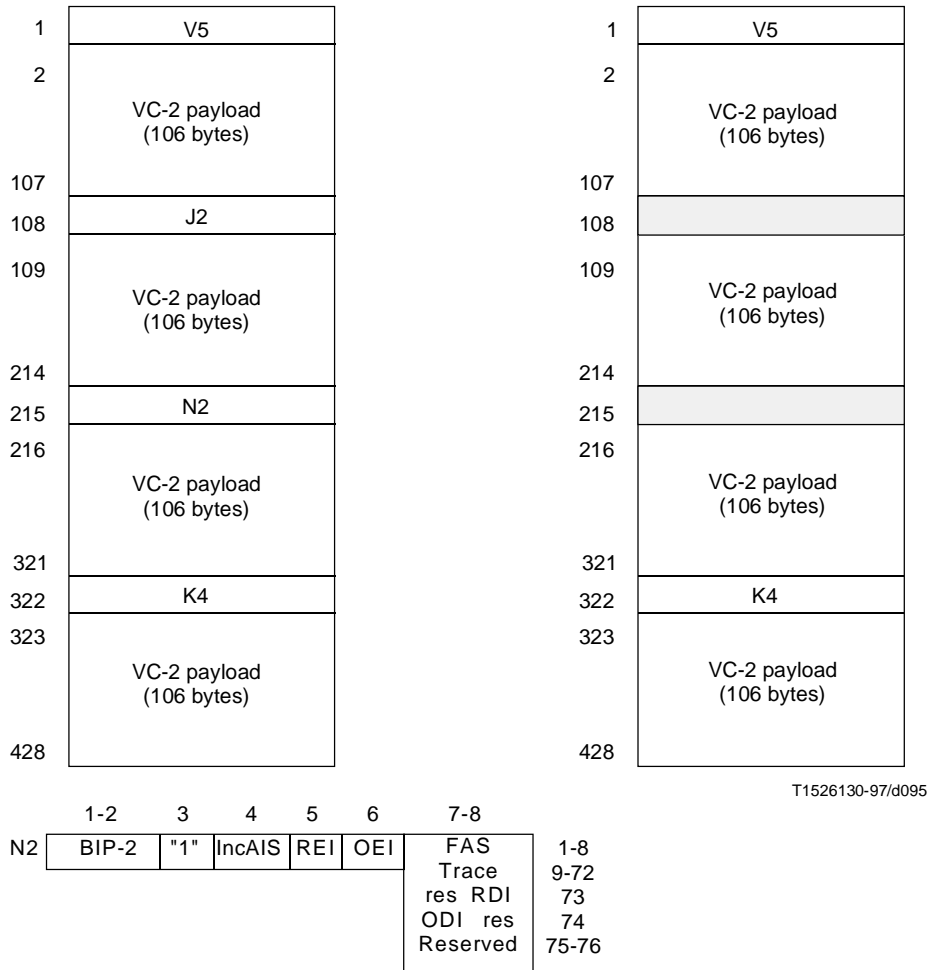

Figure 7-5/G.783 – S2_CI_D (left) with defined N2 and S2_AI_D (right)

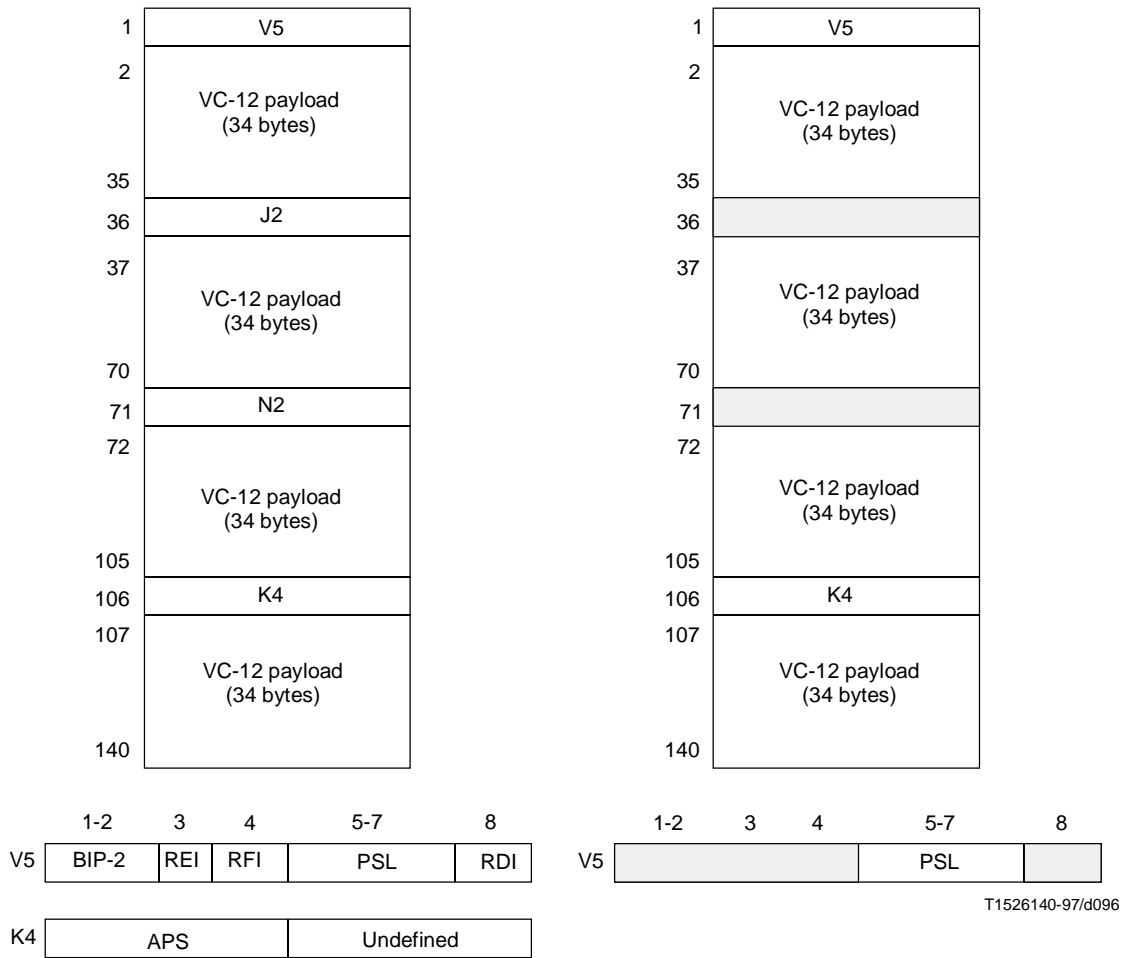

Figure 7-6/G.783 – S12_CI_D (left) and S12_AI_D (right)

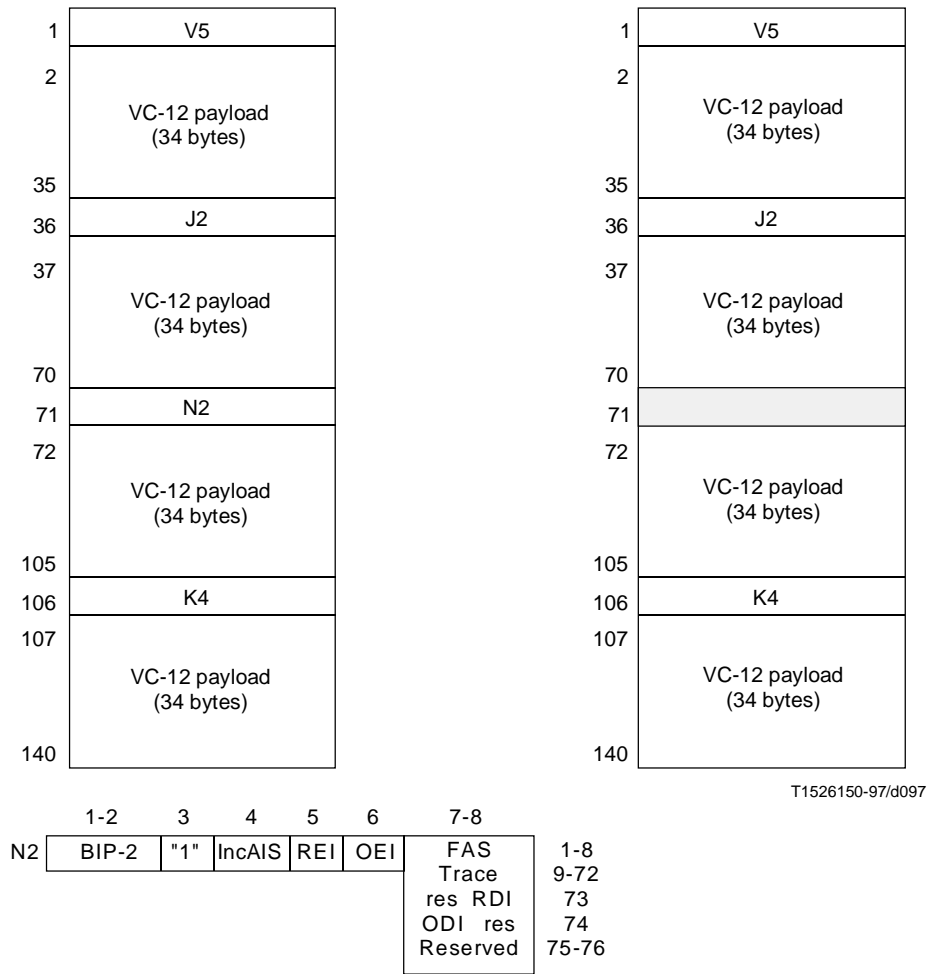

Figure 7-7/G.783 – S12_CI_D (left) with defined N2 and S12_AI_D (right)

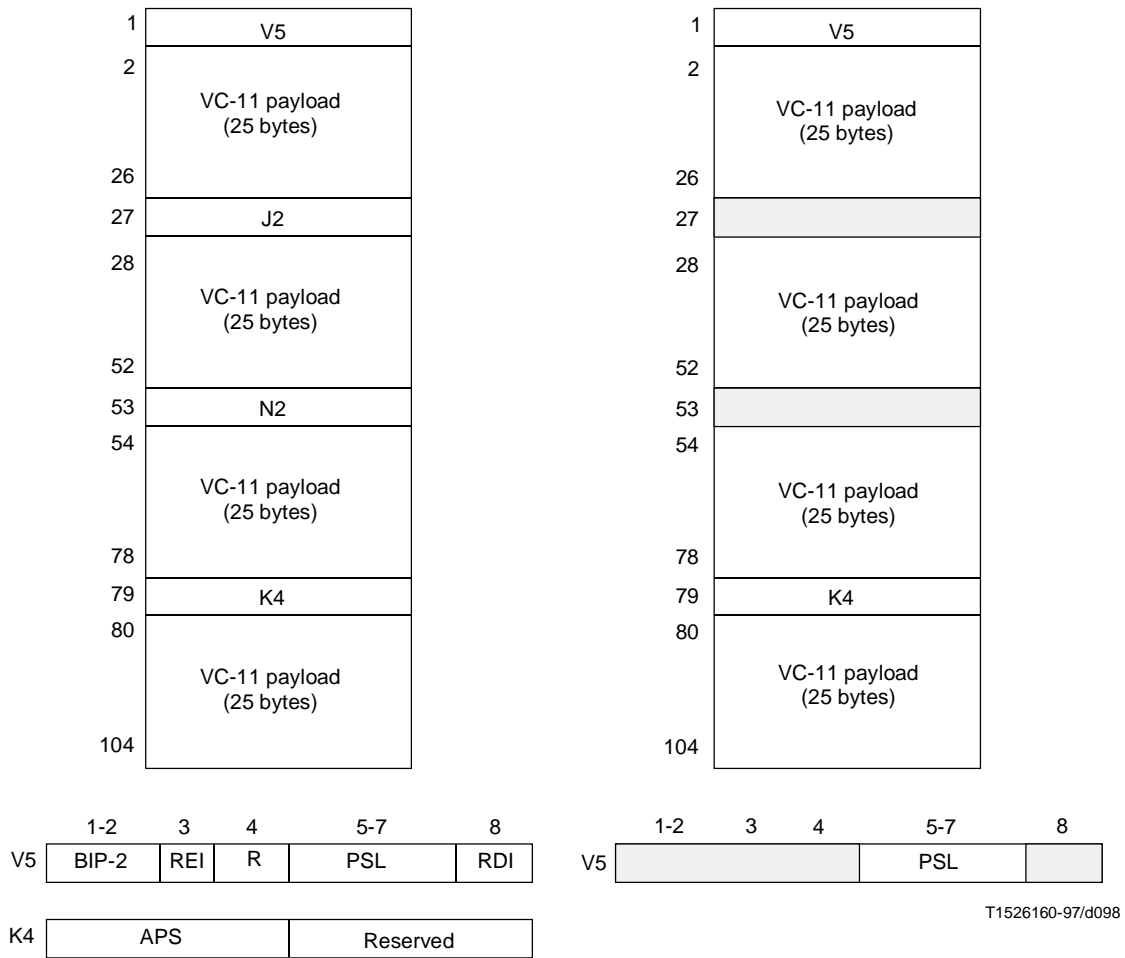

Figure 7-8/G.783 – S11_CI_D (left) and S11_AI_D (right)

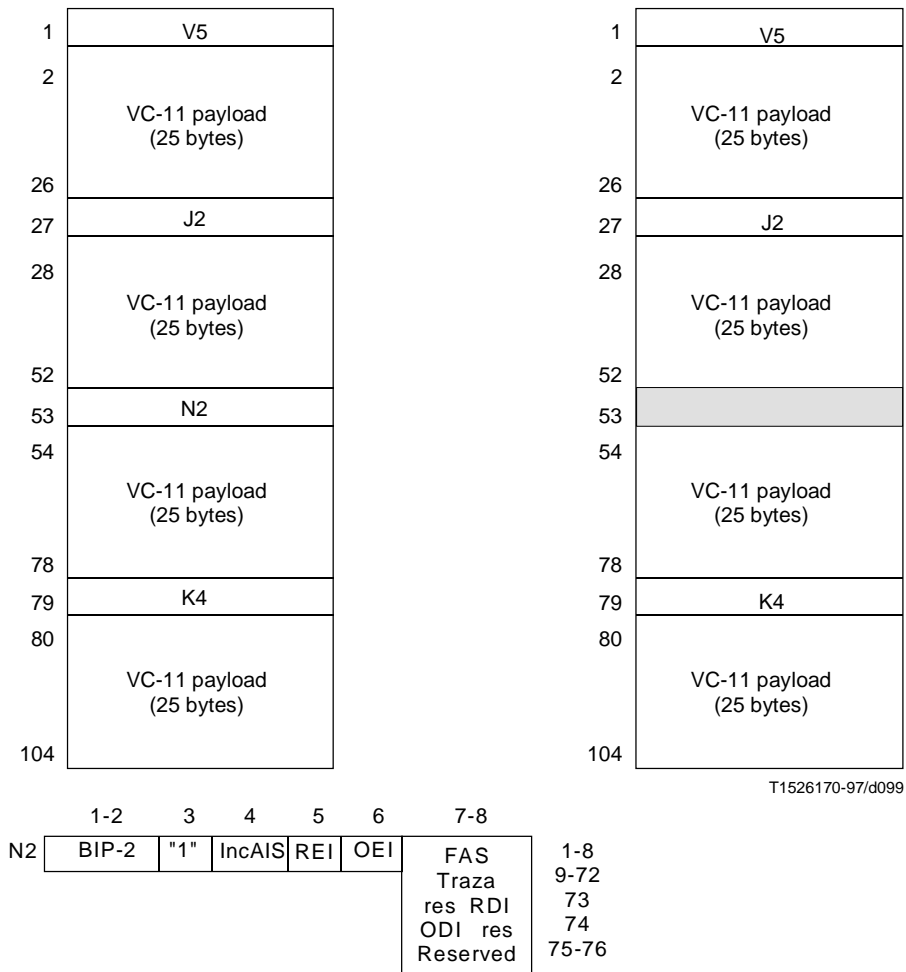

Figure 7-9/G.783 – S11_CI_D (left) with defined N2 and S11D_AI_D (right)

Layer functions

- Sm_C* Lower order path connection function
- Sm_TT* Lower order path trail termination function
- Smm_TT* Lower order non-intrusive monitor function
- Sms_TT* Lower order supervisory-unequipped termination function
- Sm/Pq_A* Lower order path adaptation functions
- Sm/User_A* Lower order path user data adaptation function
- Sm/RFI_A* Lower order path remote failure indication adaptation function
- SmP_C* Lower order trail protection connection function
- SmP_TT* Lower order path protection trail termination function
- Sm/SmP_A* Lower order path protection adaptation function
- SmD_TT* Lower order tandem connection termination function
- SmD/Sm_A* Lower order tandem connection adaptation function
- SmDm_TT* Lower order tandem connection non-intrusive monitor function

Relationship to previous versions of Recommendation G.783

The 1994 version of Recommendation G.783 refers to the LPT, LPC, LPA, LUG, LPOM basic functions. Table 7-1 shows the relationship between the basic functions and the atomic functions in the Lower order path layers.

Table 7-1/G.783 – Lower order path layer basic and atomic functions

Basic function	Atomic function
LPT	<i>Sm</i> _TT_So <i>Sm</i> _TT_Sk <i>Sm</i> /RFI_A_So <i>Sm</i> /RFI_A_Sk <i>Sm</i> /User_A_So <i>Sm</i> /User_A_Sk
LPC	<i>Sm</i> _C
LPA	<i>Sm</i> /Pq_A_So <i>Sm</i> /Pq_A_Sk <i>Eq</i> /Pqs_A_So <i>Eq</i> /Pqs_A_Sk
LUG LPOM	<i>Sms</i> _TT_So <i>Sms</i> _TT_Sk <i>Smm</i> _TT_Sk

7.1 Connection functions: *Sm*_C

7.1.1 Lower order trail connection function (*Sm*_C)

*Sm*_C is the function which assigns lower order VCs of level *m* (*m* = 11, 12, 2 or 3) at its input ports to lower order VCs of level *m* at its output ports.

The *Sm*_C connection process is a unidirectional function as illustrated in Figure 7-10. The signal formats at the input and output ports of the function are similar, differing only in the logical sequence of the VC-*m*s. As the process does not affect the nature of the characteristic information of the signal, the reference point on either side of the *Sm*_C function is the same, as illustrated in Figure 7-10.

Incoming VC-*m*s at the *Sm*_CP are assigned to available outgoing VC-*m* capacity at the *Sm*_CP.

An unequipped VC-*m* shall be applied at any outgoing VC-*m* which is not connected to an incoming VC-*m*.

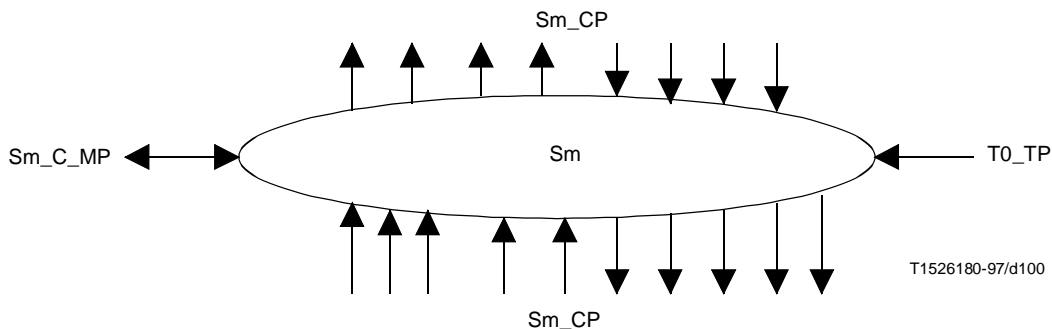

T1526180-97/d100

Figure 7-10/G.783 – General lower order trail connection function

Interface

See Table 7-2.

Table 7-2/G.783 – *Sm_C* input and output signals

Input(s)	Output(s)
<p>Per <i>Sm_CI</i>, n x for the function: <i>Sm_CI_Data</i> <i>Sm_CI_Clock</i> <i>Sm_CI_FrameStart</i> <i>Sm_CI_SSF</i> <i>Sm_AI_TSF</i> <i>Sm_AI_TSD</i></p> <p>1 x per function: <i>T0_TI_Clock</i> <i>T0_TI_FrameStart</i></p> <p>Per input and output connection point: <i>Sm_C_MI_ConnectionPortIds</i></p> <p>Per matrix connection: <i>Sm_C_MI_ConnectionType</i> <i>Sm_C_MI_Directionality</i></p> <p>Per SNC protection group: <i>Sm_C_MI_PROTtype</i> <i>Sm_C_MI_OPERtype</i> <i>Sm_C_MI_WTRtime</i> <i>Sm_C_MI_HOtime</i> <i>Sm_C_MI_EXTCMD</i></p>	<p>Per <i>Sm_CI</i>, m x per function: <i>Sm_CI_Data</i> <i>Sm_CI_Clock</i> <i>Sm_CI_FrameStart</i> <i>Sm_CI_SSF</i></p> <p>Per SNC protection group: <i>Sm_C_MI_pPSC</i> <i>Sm_C_MI_pPSSw</i> <i>Sm_C_MI_pPSSp</i> NOTE – Protection status reporting signals are for further study.</p>

Processes

In the *Sm_C* function VC-*m* Layer Characteristic Information is routed between input (termination) connection points [(T)CPs] and output (T)CPs by means of matrix connections. (T)CPs may be allocated within a protection group.

NOTE 1 – Neither the number of input/output signals to the connection function, nor the connectivity is specified in this Recommendation. That is a property of individual network elements. Examples of *Sm_C* configurations are the same as the *Sn_C* examples given in Appendix II, except that they refer to the *Sm_CP* rather than the *Sn_CP*.

Figure 7-1 presents a subset of the atomic functions that can be connected to this VC-*m* connection function: VC-*m* trail termination functions, VC-*m* non-intrusive monitor trail termination sink function, VC-*m* unequipped-supervisory trail termination functions, VC-*m* tandem connection trail termination and adaptation functions. In addition, adaptation functions in the VC-*m* server (e.g. VC-4 or VC-3) layers will be connected to this VC-*m* connection function.

Routing: The function shall be able to connect a specific input with a specific output by means of establishing a matrix connection between the specified input and output. It shall be able to remove an established matrix connection.

Each (matrix) connection in the *Sm_C* function should be characterized by the:

Type of connection:	Unprotected, 1 + 1 protected (SNC/I, SNC/N or SNC/S protection)
Traffic direction:	Unidirectional, bidirectional
Input and output connection points:	Set of connection point

NOTE 2 – Broadcast connections are handled as separate connections to the same input CP.

Provided no protection switching action is activated/required, the following changes to (the configuration of) a connection shall be possible without disturbing the CI passing the connection:

- addition and removal of protection;
- addition and removal of connections to/from a broadcast connection;
- change between operation types;
- change of WTR time;
- change of Hold-off time.

Unequipped VC generation: The function shall generate an unequipped VC-*m* signal, as specified in Recommendation G.707.

Defects

None.

Consequent actions

If an output of this function is not connected to one of its inputs, the function shall connect the unequipped VC-*m* [with valid frame start (FS) and SSF = false] to the output.

Defect correlation

None.

Performance monitoring

For each SNC protection group:

- pPSC ← According to 2.2.5.6.
- pPSSw ← According to 2.2.5.7.
- pPSSp ← According to 2.2.5.7.

7.1.1.1 Lower order subnetwork connection protection process

Lower order subnetwork connection protection mechanism is described in Recommendation G.841.

Figure 7-11 gives the atomic functions involved in SNC protection. Bottom to the left is the two (working and protection) adaptation function (*Sn/Sm_A*) pairs. Above them is the non-intrusive monitoring functions (*Smm_TT_Sk*), in case of SNC/N they are not present. To the right is either the trail termination functions (*Sm_TT*) or the adaptation functions (*Sn/Sm_A*) depending on if the *Sm* trail is terminated at the same point the SNC protection is terminated or at a later point.

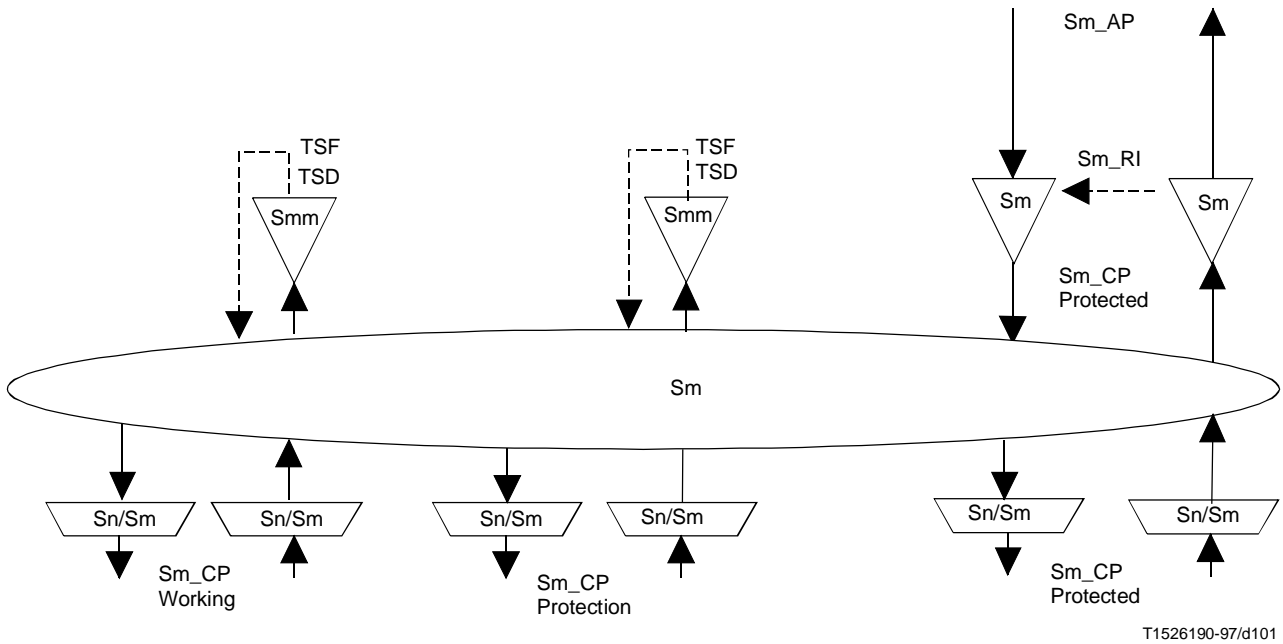

Figure 7-11/G.783 – Low order SDH SNC/N protection atomic functions

T1526190-97/d101

The *Sm_C* function may provide protection for the lower order trail against channel-associated defects within a lower order (sub)network connection.

The *Sm_C* functions at both ends operate the same way, by monitoring the lower subnetwork connections for defects, evaluating the system status taking into consideration the priorities of defect conditions and of external switch requests, and switching the appropriate channel to the protection (sub)network connection.

The signal flow associated with the *Sm_C* SNC protection process is described with reference to Figures 7-12 and 7-13. The *Sm_C* SNC protection process receives control parameters and external switch requests at the *Sm_C_MP* reference point from the synchronous equipment management function and outputs status indicators at the *Sm_C_MP* to the synchronous equipment management function, as a result of switch commands described in Recommendation G.841.

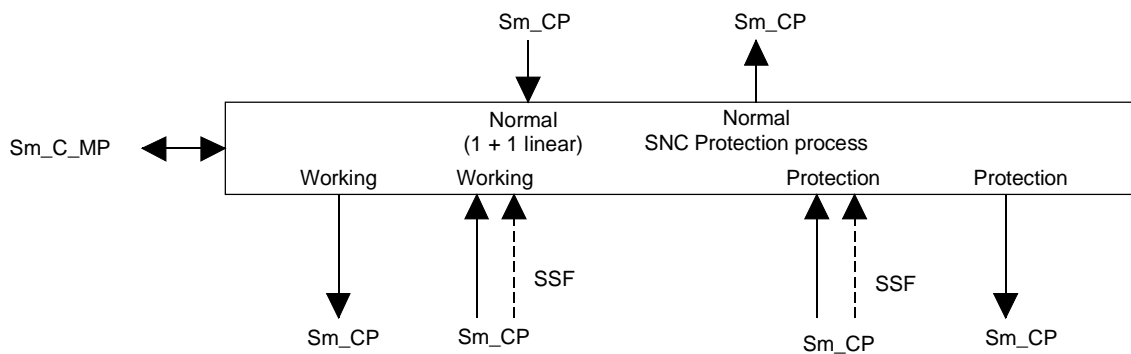
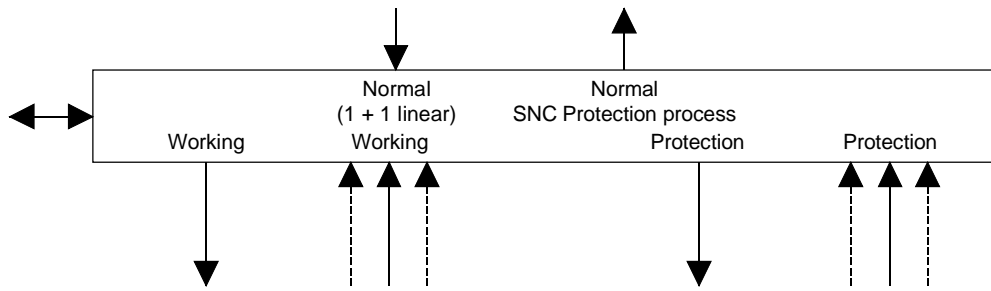

Figure 7-12/G.783 – Lower order inherent monitored subnetwork connection (SNC/I) protection process

T1526200-97/d102



T1526210-97/d103

Figure 7-13/G.783 – Lower order non-intrusive monitored subnetwork connection (SNC/N) protection process

7.1.1.1.1 Source direction

Data at the *Sm_CP* is a lower order trail signal.

For 1 + 1 architecture, the signal received at the *Sm_CP* from the *Sn/Sm_A* (or *Sm_TT*) function is bridged permanently at the *Sm_CP* to both working and protection *Sn/Sm_A* functions.

NOTE – The basic element connected at the *Sm_CP* to the *Sm_C* is either an *Sn/Sm_A* or an *Sm_TT*. When the LO VC-*m* signal is terminated in this network element, it will be connected at the *Sm_CP* to an *Sm_TT*, otherwise it will be connected at the *Sm_CP* to an *Sn/Sm_A* (for further transport).

7.1.1.1.2 Sink direction

Framed lower order trail signals (data) *Sm_CI* are presented at the *Sm_CP* along with incoming timing references. The defect condition(s) SSF (and TSF and TSD) are also received at the *Sm_CP* from all *Sn/Sm_A* [or *Smm_TT_Sk*, $m = (11, 12, 2 \text{ or } 3)$] functions.

For the SNC/I protection (Figure 7-12) the lower order trail signals pass the *Sn/Sm_A* functions. The SSF signals from the *Sn/Sm_A_Sk* are used by the *Sm_C* SNC protection process.

For the SNC/N protection (Figure 7-13) the lower order trail signals are broadcast to *Smm_TT_Sk* function for non-intrusive monitoring of the lower order trail. The resultant TSF, TSD signals are used by the *Sm_C* SNC protection process instead of the SSF signal from the *Sn/Sm_A*.

Under normal conditions, *Sm_C* passes the data and timing from the working *Sn/Sm_A* functions to the *Sn/Sm_A* (or *Sm_TT*) function at the *Sm_CP*. The data and timing from the protection (sub)network connection is not forwarded.

If a switch is to be performed, then the data and timing received from the protection *Sn/Sm_A* at the *Sm_CP* is switched to the *Sn/Sm_A* (or *Sm_TT*) function at the *Sm_CP*, and the signal received from the working *Sn/Sm_A* at the *Sm_CP* is not forwarded.

7.1.1.1.3 Switch initiation criteria

Automatic protection switching is based on the defect conditions of the working and protection (sub)network connections. These condition(s) are for SNC/I server signal fail (SSF) and for SNC/N Trail Signal Fail (TSF) and Trail Signal Degrade (TSD). Detection of these conditions is described in 6.3.1 for *Sn/Sm_A* and 7.2.2 for *Smm_TT_Sk*, $m = (11, 12, 2 \text{ or } 3)$.

The protection switch can also be initiated by switch commands received via the synchronous equipment management function. See the switch initiation criteria described in Recommendation G.841.

7.1.1.1.4 Switching time

Protection switching shall be completed within TBD ms of detection of an SSF, TSF or SD condition that initiates a switch.

The protection switch completion time is for further study. A proposal is a basic switch time (T_{bs}) (after defect detection) of 100 ms increased by a provisionable hold-off time T_{ho} , with $0 \leq T_{ho} \leq 10$ s.

7.1.1.1.5 Switch restoration

In the revertive mode of operation, the working channel shall be restored, i.e. the signal on the protection (sub)network connection shall be switched back to the working (sub)network connection, when the working (sub)network connection has recovered from the fault.

To prevent frequent operation of the protection switch due to an intermittent fault, a failed (sub)network connection must become fault-free. After the failed (sub)network connection meets this criterion, a fixed period of time shall elapse before it is used again by a working channel. This period, called Wait to Restore (WTR) period should be of the order of 5-12 minutes and should be capable of being set. An SSF, TSF or TSD condition shall override the WTR.

7.2 Termination functions: Sm_TT , Smm_TT and Sms_TT

7.2.1 Lower order trail termination (Sm_TT)

The Lower order Path termination function comprises the atomic functions Lower order path trail termination source [Sm_TT_So , $m = (11, 12, 2 \text{ or } 3)$] and sink [Sm_TT_Sk , $m = (11, 12, 2 \text{ or } 3)$] as illustrated in Figure 7-14 and Tables 7-3 and 7-4.

The Sm_TT source function creates a VC- m ($m = 11, 12, 2, \text{ or } 3$) at the Sm_CP by generating and adding POH to a container C- m from the Sm_AP . In the other direction of transmission it terminates and processes the POH to determine the status of the defined path attributes. The POH formats are defined in Recommendation G.707. The information flows associated with the Sm_TT functions are described in Figure 7-14 and Tables 7-3 and 7-4.

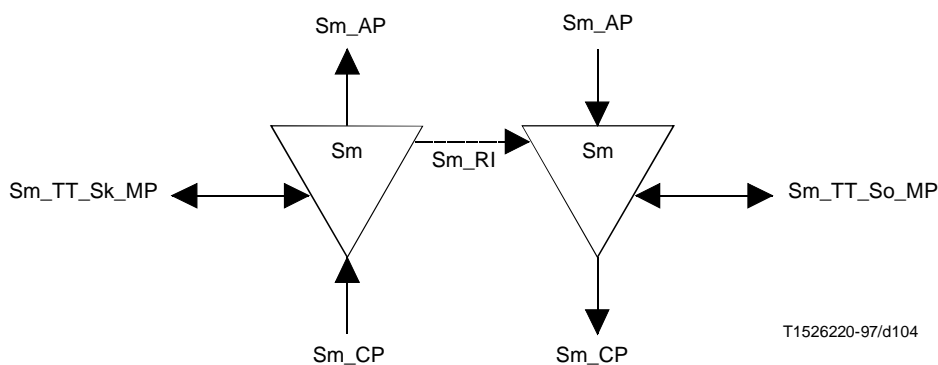

Figure 7-14/G.783 – Lower order trail termination function

Referring to Figure 7-14, data at the Sm_AP takes the form of a container C- m ($m = 1, 2, 3$) which is synchronized to the timing reference $T0_TP$.

Synchronously adapted information in the form of synchronous containers (data) and the associated container frame offset information (frame offset) are received at the Sm_AP .

7.2.1.1 Case of VC-11, 12 and 2

The VC-1/VC-2 POH is carried in the J2, K4, N2, and V5 bytes as defined in Recommendation G.707.

7.2.1.1.1 Source direction

This function adds error monitoring and status overhead bits to the *Sm_AP*.

Data at the *Sm_AP* is a VC-*m* (*m* = 11, 12, 2 or 3), having a payload as described in Recommendation G.707, but with indeterminate VC-*m* POH bytes: J2, V5. These POH bytes are set as part of the *Sm_TT* function and the complete VC-*m* is forwarded to the *Sm_CP*.

Interfaces

Table 7-3/G.783 – *Sm_TT_So* input and output signals

Input(s)	Output(s)
<i>Sm_AI_Data</i> <i>Sm_AI_Clock</i> <i>Sm_AI_FrameStart</i> <i>Sm_RI_RDI</i> <i>Sm_RI_REI</i> <i>Sm_TT_So_MI_TxTI</i>	<i>Sm_CI_Data</i> <i>Sm_CI_Clock</i> <i>Sm_CI_FrameStart</i>

Processes

J2: The trail trace identifier should be generated. Its value is derived from reference point *Sm_TT_So_MP*. The path trace format is described in 2.2.2.4.

V5[1-2]: BIP-2 shall be calculated on data at the *Sm_CP* on the previous frame and the result transmitted in bits 1 and 2 of the V5 byte.

V5[3]: The number of errors indicated in *RI_REI* is encoded in the REI bit.

V5[8]: When there is an active *RI_RDI*, the RDI indication shall be sent in bit 8 of the V5 byte within 1000 μs. Upon termination of the above conditions, the RDI indication shall be removed within 1000 μs.

K4[5-8]: These bits are undefined.

N2: This byte is undefined.

Defects

None.

Consequent actions

None.

Defect correlation

None.

Performance monitoring

None.

7.2.1.1.2 Sink direction

This function monitors the lower order VC-*m* [*m* = (11, 12 or 2)] for errors, and recovers the trail termination status. It extracts the payload independent overhead bytes/bits (J2, V5[1-2], V5[3], V5[5-7], V5[8]) from the VC-*m* layer Characteristic Information.

Interfaces

Table 7-4/G.783 – *Sm_TT_Sk* input and output signals

Input(s)	Output(s)
<i>Sm_CI_Data</i> <i>Sm_CI_Clock</i> <i>Sm_CI_FrameStart</i> <i>Sm_CI_SSF</i> <i>Sm_TT_Sk_MI_TPmode</i> <i>Sm_TT_Sk_MI_ExTI</i> <i>Sm_TT_Sk_MI_RDI_Reported</i> <i>Sm_TT_Sk_MI_DEGTHR</i> <i>Sm_TT_Sk_MI_DEGM</i> <i>Sm_TT_Sk_MI_1second</i> <i>Sm_TT_Sk_MI_TIMdis</i>	<i>Sm_AI_Data</i> <i>Sm_AI_Clock</i> <i>Sm_AI_FrameStart</i> <i>Sm_AI_TSF</i> <i>Sm_AI_TSD</i> <i>Sm_RI_RDI</i> <i>Sm_RI_REI</i> <i>Sm_TT_Sk_MI_cTIM</i> <i>Sm_TT_Sk_MI_cUNEQ</i> <i>Sm_TT_Sk_MI_cEXC</i> <i>Sm_TT_Sk_MI_cDEG</i> <i>Sm_TT_Sk_MI_cRDI</i> <i>Sm_TT_Sk_MI_AcTI</i> <i>Sm_TT_Sk_MI_pN_EBC</i> <i>Sm_TT_Sk_MI_pN_DS</i> <i>Sm_TT_Sk_MI_pF_EBC</i> <i>Sm_TT_Sk_MI_pF_DS</i>

Processes

J2: The trail trace identifier is recovered from VC-*m* POH at the *Sm_CP* and processed as specified in 2.2.2.4. The accepted value of J2 is also available at the *Sm_TT_Sk_MP*. For further description of trace identifier mismatch processing, see 2.2.2.4.

V5[5-7]: The unequipped defect is processed as described in 2.2.2.2.

V5[1-2]: The error monitoring bits at the *Sm_CP* shall be recovered. BIP-2 is computed for the VC-*m* frame. The computed BIP-2 value for the current frame is compared with the recovered bits 1 and 2 from the following frame.

The process for detecting excessive errors and signal degrade is described in 2.2.2.5.

V5[3]: The REI shall be recovered and the derived performance primitives should be reported at the *Sm_TT_Sk_MP*.

V5[8]: The RDI defect is processed as described in 2.2.2.6.

N2: The network operator byte is defined for TC monitoring. It shall be ignored by this function.

K4[5-8]: These bits are undefined.

Defects

The function shall detect for dUNEQ, dTIM, dEXC, dDEG and dRDI defects according to the specification in 2.2.2.

Consequent actions

The function shall perform the following consequent actions (see 2.2.3):

aAIS ← dUNEQ or dTIM
aRDI ← CI_SSF or dUNEQ or dTIM
aREI ← nN_B
aTSF ← CI_SSF or dUNEQ or dTIM
aTSFprot ← aTSF or dEXC
aTSD ← dDEG

Defect correlation

The function shall perform the following defect correlation to determine the most probable fault cause (see 2.2.4). This fault cause shall be reported to the SEMF.

- cUNEQ ← dUNEQ and MON
- cTIM ← dTIM and (not dUNEQ) and MON
- cEXC ← dEXC and (not dTIM) and MON
- cDEG ← dDEG and (not dTIM) and MON
- cRDI ← dRDI and (not dUNEQ) and (not dTIM) and MON and RDI_Reported

Performance monitoring

The function shall perform the following performance monitoring primitives processing (see 2.2.5). The performance monitoring primitives shall be reported to the SEMF.

- pN_DS ← aTSF or dEQ
- pF_DS ← dRDI
- pN_EBC ← Σ nN_B
- pF_EBC ← Σ nF_B

7.2.1.2 Case of VC-3

The VC-*m* path overhead (for *m* = 3) is the same as the path overhead for VC-*n* (*n* = 3) and is described in 6.2.1.

7.2.2 Lower order non-intrusive monitor (Smm_TT)

The Lower order Path overhead monitor function comprises the atomic function Lower order non-intrusive monitor sink [*Smm_TT_Sk*, *m* = (11, 12, 2 or 3)] illustrated in Figure 7-15 and Table 7-5.

The *Sm_TT* function processes the POH to determine the status of the defined path attributes. The POH formats are defined in Recommendation G.707. The information flows associated with the *Smm_TT* function are described in Figure 7-15 and Table 7-5.

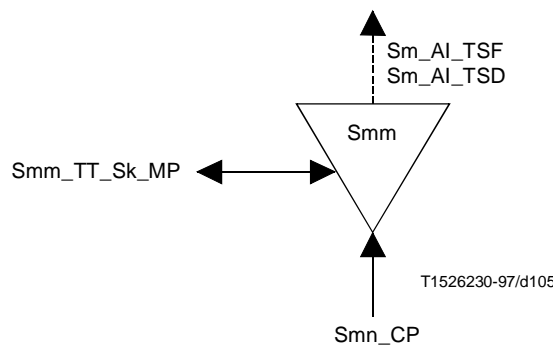

Figure 7-15/G.783 – Lower order non-intrusive monitor function

7.2.2.1 Case of VC-11, 12 and 2

7.2.2.1.1 Sink direction

This function monitors the lower order VC-*m* [*m* = (11, 12 or 2)] for errors, and recovers the trail termination status. It extracts the payload independent overhead bytes/bits (J2, V5[1-2], V5[3], V5[5-7], V5[8]) from the VC-*m* layer Characteristic Information.

Interfaces

Table 7-5/G.783 – Smm_TT_Sk input and output signals

Input(s)	Output(s)
<i>Sm_CI_Data</i> <i>Sm_CI_Clock</i> <i>Sm_CI_FrameStart</i> <i>Sm_CI_SSF</i>	<i>Sm_AI_TSF</i> <i>Sm_AI_TSD</i>
<i>Smm_TT_Sk_MI_TPmode</i> <i>Smm_TT_Sk_MI_ExTI</i> <i>Smm_TT_Sk_MI_RDI_Reported</i> <i>Smm_TT_Sk_MI_DEGTHR</i> <i>Smm_TT_Sk_MI_DEGM</i> <i>Smm_TT_Sk_MI_1second</i> <i>Smm_TT_Sk_MI_TIMdis</i>	<i>Smm_TT_Sk_MI_cTIM</i> <i>Smm_TT_Sk_MI_cUNEQ</i> <i>Smm_TT_Sk_MI_cDEG</i> <i>Smm_TT_Sk_MI_cRDI</i> <i>Smm_TT_Sk_MI_cAIS</i> <i>Smm_TT_Sk_MI_AcTI</i> <i>Smm_TT_Sk_MI_pN_EBC</i> <i>Smm_TT_Sk_MI_pF_EBC</i> <i>Smm_TT_Sk_MI_pN_DS</i> <i>Smm_TT_Sk_MI_pF_DS</i>

Processes

J2: The trail trace identifier is recovered from VC-*m* POH at the *Sm_CP*. The accepted value of J2 is also available at the *Smm_TT_Sk_MP*. For further description of trace identifier mismatch processing, see 2.2.2.4.

V5[5-7]: The signal label bits at the *Sm_CP* shall be recovered. For further description of unequipped defect processing, see 2.2.2.2. The function shall detect for an AIS VC (VC-AIS) condition by monitoring the VC_SL for code "111". For further description of VC-AIS defect processing, see 2.2.2.3.

V5[1-2]: The error monitoring bits at the *Sm_CP* shall be recovered. BIP-2 is computed for the VC-*m* frame. The computed BIP-2 value for the current frame is compared with the recovered bits 1 and 2 from the following frame.

The process for detecting excessive errors and signal degrade from V5 bit 1, 2 is described in 2.2.2.5.

V5[3]: REI in bit 3 shall be recovered and the derived performance primitives should be reported at the *Smm_TT_MP*. See below.

V5[8]: The path RDI information in bit 8 shall be recovered and reported at the *Smm_TT_Sk_MP*. For further description of RDI defect processing, see 2.2.2.6.

N2: The network operator byte is defined for TC monitoring. It shall be ignored by this function.

Defects

The function shall detect for dUNEQ, dTIM, dEXC, dDEG, dAIS and dRDI defects according to the specification in 2.2.2.

Consequent actions

The function shall perform the following consequent actions (see 2.2.3):

aTSF ← CI_SSF or dAIS or dUNEQ or dTIM

aTSFprot ← dEXC or aTSF

aTSD ← dDEG

Defect correlation

The function shall perform the following defect correlation to determine the most probable fault cause (see 2.2.4). This fault cause shall be reported to the SEMF.

cAIS ← dAIS and MON and AIS_Reported

cUNEQ ← dUNEQ and MON

- cTIM ← dTIM and (not dUNEQ) and MON
- cEXC ← dEXC and (not dTIM) and MON
- cDEG ← dDEG and (not dTIM) and MON
- cRDI ← dRDI and (not dUNEQ) and (not dTIM) and MON and RDI_Reported

Performance monitoring

The function shall perform the following performance monitoring primitives processing (see 2.2.5). The performance monitoring primitives shall be reported to the SEMF.

- pN_DS ← aTSF or dEQ
- pF_DS ← dRDI
- pN_EBC ← ΣnN_B
- pF_EBC ← ΣnF_B

7.2.2.2 Case of VC-3

The VC-*m* path overhead (for *m* = 3) is the same as the path overhead for VC-*n* (*n* = 3) and is described in 6.2.2.

7.2.3 Lower order supervisory-unequipped termination (Sms_TT)

The Lower order Supervisory-unequipped function comprises the atomic functions Lower order Supervisory unequipped termination source [*Sms_TT_So*, *m* = (11, 12, 2 or 3)] and sink [*Sms_TT_Sk*, *m* = (11, 12, 2 or 3)] as illustrated in Figure 7-16 and Tables 7-6 and 7-7.

The *Smm_TT* function creates a VC-*m* (*m* = 11, 12, 2, or 3) at the *Sm_CP* by generating and adding POH to an undefined container *C-m*. In the other direction of transmission it terminates and processes the POH to determine the status of the defined path attributes. The POH formats are defined in Recommendation G.707. The information flows associated with the *Sm_TT* function are described in Figure 7-16 and Tables 7-6 and 7-7.

NOTE – The *Sms_TT* [*m* = (11, 12, 2 or 3)] function generates and monitors supervisory unequipped signals.

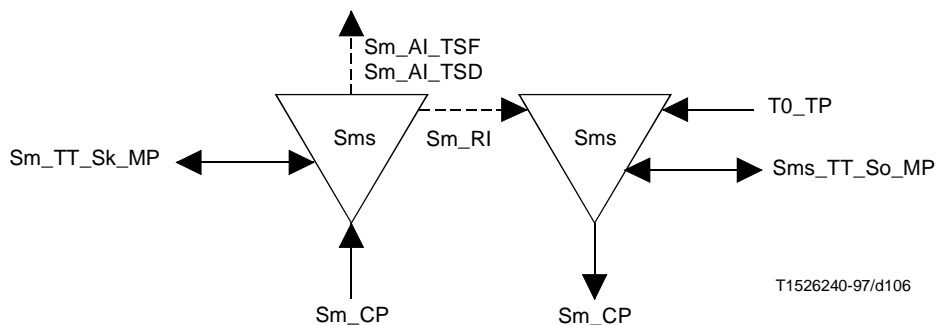

Figure 7-16/G.783 – Lower order supervisory unequipped termination function

7.2.3.1 Case of VC-11, 12 and 2

7.2.3.1.1 Source direction

This function generates error monitoring and status overhead bytes to an undefined VC-*m* [*m* = (11, 12 or 2)].

Interfaces

Table 7-6/G.783 – Sms_TT_So input and output signals

Input(s)	Output(s)
<i>Sms_RI_RDI</i> <i>Sms_RI_REI</i> <i>T0_TI_Clock</i> <i>T0_TI_FrameStart</i> <i>Sm_RI_RDI</i> <i>Sm_RI_REI</i> <i>Sms_TT_So_MI_TxTI</i>	<i>Sm_CI_Data</i> <i>Sm_CI_Clock</i> <i>Sm_CI_FrameStart</i>

Processes

An undefined VC-*m* [*m* = (11, 12 or 2)] should be generated.

V5[5-7]: Signal label 000 (unequipped) should be inserted in the VC-*m*.

J2: The trail trace identifier should be generated. Its value is derived from reference point *Sms_TT_MP*. The trail trace format is described in 2.2.2.4.

V5[1-2]: BIP-2 shall be calculated on data at the *Sms_AP* on the previous frame and the result transmitted in bits 1 and 2 of the V5 byte.

V5[3]: The number of errors indicated in RI_REI is encoded in the REI.

V5[8]: Bit 8 of byte V5, an RDI indication, shall be set to "1" on activation of RI_RDI within 1000 μ s, determined by the associated *Sms_TT_Sk* function, and set to "0" within 1000 μ s on clearing of RI_RDI.

N2: In the TCM byte, 00000000 should be inserted.

Defects

None.

Consequent actions

None.

Defect correlation

None.

Performance monitoring

None.

7.2.3.1.2 Sink direction

This function monitors VC-*m* [*m* = (11, 12 or 2)] for errors, and recovers the trail termination status. It extracts the payload independent overhead bytes/bits (J2, V5[1-2], V5[3], V5[5-7], V5[8]) from the VC-12 layer Characteristic Information.

Interfaces

Table 7-7/G.783 – Sms_TT_Sk input and output signals

Input(s)	Output(s)
<i>Sm_CI_Data</i> <i>Sm_CI_Clock</i> <i>Sm_CI_FrameStart</i> <i>Sm_CI_SSF</i>	<i>Sm_AI_TSF</i> <i>Sm_AI_TSD</i>
<i>Sms_TT_Sk_MI_TPmode</i> <i>Sms_TT_Sk_MI_ExTI</i> <i>Sms_TT_Sk_MI_RDI_Reported</i> <i>Sms_TT_Sk_MI_DEGTHR</i> <i>Sms_TT_Sk_MI_DEGM</i> <i>Sms_TT_Sk_MI_1second</i> <i>Sms_TT_Sk_MI_TIMdis</i>	<i>Sm_RI_RDI</i> <i>Sm_RI_REI</i>
	<i>Sms_TT_Sk_MI_cTIM</i> <i>Sms_TT_Sk_MI_cUNEQ</i> <i>Sms_TT_Sk_MI_cDEG</i> <i>Sms_TT_Sk_MI_cRDI</i> <i>Sms_TT_Sk_MI_AcTI</i>
	<i>Sms_TT_Sk_MI_pN_EBC</i> <i>Sms_TT_Sk_MI_pF_EBC</i> <i>Sms_TT_Sk_MI_pN_DS</i> <i>Sms_TT_Sk_MI_pF_DS</i>

Processes

J2: The trail trace identifier is recovered from VC-*m* POH at the *Sm_CP*. The accepted value of the trail trace identifier is also available at the *Sms_TT_MP*. For further description of trace identifier mismatch processing, see 2.2.2.4.

V5[5-7]: The signal label at the *Sm_CP* shall be recovered. Note that the *Sms_TT* sink direction always expects an unequipped signal label. For further description of unequipped defect processing, see 2.2.2.2.

V5[1-2]: The error monitoring bits at the *Sm_CP* shall be recovered. BIP-2 is computed for the VC-*m* frame. The computed BIP-2 value for the current frame is compared with the recovered bits 1 and 2 from the following frame.

The process for detecting excessive errors and signal degrade from BIP-2 is described in 2.2.2.5.

V5[3]: The REI shall be recovered and the derived performance primitives should be reported at the *Sms_TT_MP*. See below.

V5[8]: The path RDI information shall be recovered and reported at the *Sms_TT_MP*. For further description of RDI defect processing, see 2.2.2.6.

N2: The network operator byte is defined for TC monitoring. It shall be ignored by this function.

Defects

The function shall detect for dUNEQ, dTIM, dEXC, dDEG and dRDI defects according to the specification in 2.2.2.

Consequent actions

The function shall perform the following consequent actions (see 2.2.3):

aRDI ← CI_SSF or dTIM

aREI ← Σ nN_B

aTSF ← CI_SSF or dTIM

aTSFprot ← aTSF or dEXC

aTSD ← dDEG

Defect correlation

The function shall perform the following defect correlation to determine the most probable fault cause (see 2.2.4). This fault cause shall be reported to the SEMF.

cUNEQ ← dTIM and (AcTI = all zeroes) and dUNEQ and MON
 cTIM ← dTIM and [not (dUNEQ and AcTI = all zeroes)] and MON
 cEXC ← dEXC and (not dTIM) and MON
 cDEG ← dDEG and (not dTIM) and MON
 cRDI ← dRDI and (not dTIM) and MON and RDI_Reported

Performance monitoring

The function shall perform the following performance monitoring primitives processing (see 2.2.5). The performance monitoring primitives shall be reported to the SEMF.

pN_DS ← aTSF or dEQ
 pF_DS ← dRDI
 pN_EBC ← Σ nN_B
 pF_EBC ← Σ nF_B

7.2.3.2 Case of VC-3

The VC-*m* path overhead (for *m* = 3) is the same as the path overhead for VC-*n* (*n* = 3) and is described in 6.2.3.

7.3 Adaptation functions

7.3.1 Lower order trail adaptation function (*Sm/Pqx_A*, *Sm/Pqs_A*)

Sm/Pqx_A or *Sm/Pqs_A* [*m* = (11, 12, 2 or 3), *q* = (11, 12, 21, 31, 32)] operates at the access port to a synchronous network or subnetwork and adapts user data for transport in the synchronous domain. The *Sm/Pqx_A* or *Sm/Pqs_A* function acts also as a source and sink for the POH payload dependent information. For asynchronous user data, lower order path adaptation involves bit justification. The *Sm/Pqx_A* or *Sm/Pqs_A* function maps G.703 (PDH) signals into lower order containers which may subsequently be mapped into higher order containers. The information flows associated with the lower order adaptation function are shown in Figure 7-17 Tables 7-9, 7-10, 7-11 and 7-12.

The Lower order path adaptation function comprises the atomic functions Lower order path adaptation source and sink.

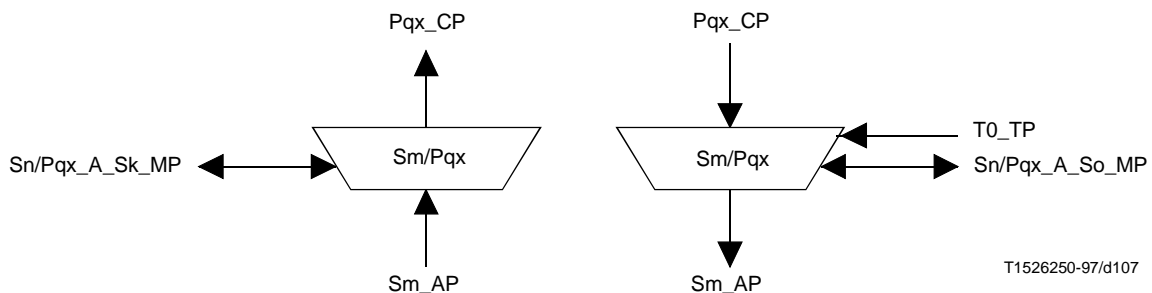

NOTE – In case of byte synchronous mappings, Pqx should be read as Pqs.

Figure 7-17/G.783 – Lower order path adaptation function

Adaptation functions are defined for each of the levels in the existing plesiochronous hierarchies. Each adaptation function defines the manner in which a user signal can be mapped into one of a range of synchronous containers C-*m* of appropriate size. The container sizes have been chosen for ease of mapping various combinations of sizes into high order containers; see Table 7-8. Detailed specifications for mapping user data into containers are given in Recommendation G.707.

Table 7-8/G.783 – Container sizes

Atomic function	Server layer	Client layer	Signal label	Container size	Mapping type
S11/P11x-bit_A	S11	P11x	011	C-11	bit sync.
S11/P11s-b_A_Sk S11/P11s-x_A_So	S11	P11s	100	C-11	byte sync.
S11/P11x_A	S11	P11x or P11s	010	C-11	async.
S12/P12s-b_A_So S12/P12s-x_A_Sk	S12	P12s	100	C-12	byte sync.
S12/P12x_A	S12	P12x or P12s	010	C-12	async.
S2/P21x_A	S2	P21x	010	C-2	async.
S3/P31x_A	S3	P31x	0000 0100	C-3	async.
S3/P32x_A	S3	P32x	0000 0100	C-3	async.

7.3.1.1 Source direction

Interfaces

Table 7-9/G.783 – Sm/Pqx_A_So input and output signals

Input(s)	Output(s)
Pqx_CI_Data Pqx_CI_Clock T0_TI_Clock T0_TI_FrameStart Sm/Pqx_A_So_MI_Active	Sm_AI_Data Sm_AI_Clock Sm_AI_FrameStart

Table 7-10/G.783 – Sm/Pqs_A_So input and output signals

Input(s)	Output(s)
Pqs_CI_Data Pqs_CI_Clock Pqs_CI_FrameStart Sm/Pqs_A_So_MI_Active	Sm_AI_Data Sm_AI_Clock Sm_AI_FrameStart

Processes

Data at the Pqx_CP (or Pqs_CP) is the user information stream. Timing of the data is also delivered as timing at the CP. Data is adapted according to one of the adaptation functions referred to above. This involves synchronization and mapping of the information stream into a container as described in Recommendation G.707 and adding of payload dependent functions.

The container is passed to the *Sm*_AP (or *Sn*_AP in the case of direct mapping) as data together with frame offset which represents the offset of the container frame with respect to reference point T0_TP. In byte synchronous mappings, the frame offset is obtained from the associated framer in the PDH layer function (E11/P11s_A_Sk or E12/P12s_A_Sk). This frame offset is constrained by the requirements of the client layer; e.g. for SDH equipment, the timing of the client layer is specified in Recommendation G.813. In other mappings, a convenient fixed offset can be generated internally.

C2 or V5[5-8]: The signal label shall be inserted in C2 (in case of VC-3) or in bits 5, 6, and 7 of V5 byte (in case of VC-11, VC-12 or VC-2) according to the type of mapping used by the adaptation function, see Table 7-8.

Defects

None.

Consequent actions

None.

Defect correlation

None.

Performance monitoring

None.

7.3.1.2 Sink direction

Interfaces

Table 7-11/G.783 – *Sm/Pqx_A_Sk* input and output signals

Input(s)	Output(s)
<i>Sm</i> _AI_Data <i>Sm</i> _AI_Clock <i>Sm</i> _AI_FrameStart <i>Sm</i> _AI_TSF <i>Sm/Pqx_A_Sk_MI_Active</i>	<i>Pqx</i> _CI_Data <i>Pqx</i> _CI_Clock <i>Sm/Pqx_A_Sk_MI_cPLM</i> <i>Sm/Pqx_A_Sk_MI_AcSL</i>

Table 7-12/G.783 – *Sm/Pqs_A_Sk* input and output signals

Input(s)	Output(s)
<i>Sm</i> _AI_Data <i>Sm</i> _AI_Clock <i>Sm</i> _AI_FrameStart <i>Sm</i> _AI_TSF <i>Sm/Pqs_A_Sk_MI_Active</i>	<i>Pqs</i> _CI_Data <i>Pqs</i> _CI_Clock <i>Sm/Pqs_A_Sk_MI_cPLM</i> <i>Sm/Pqs_A_Sk_MI_AcSL</i>

Processes

The information stream data at the *Sm*_AP is presented as a container together with frame offset. The user information stream is recovered from the container together with the associated clock suitable for tributary line timing and passed to the reference point *Pqx*_CP (or *Pqs*_CP) as data and timing. This involves de-mapping and desynchronizing as described in Recommendation G.707 and payload dependent information.

NOTE – Other signals may be required from *Sm*_CP to generate overhead and maintenance information for byte-synchronously mapped G.703 (PDH) signals. This is for further study.

C2 or V5[5-7]: Signal label, byte C2 (in case of VC-4 or VC-3) or in bits 5, 6, and 7 of V5 byte (in case of VC-11, VC-12 or VC-2), is recovered. For further description of signal label processing, see 2.2.2.7.

Defects

The function shall detect for dPLM defects according to the specification in 2.2.2.

Consequent actions

The function shall perform the following consequent actions (see 2.2.3):

aAIS ← AI_TSF or dPLM

aSSF ← AI_TSF or dPLM

When AIS is applied at the *Sm*_AP or *Sn*_AP, or a dPLM defect is detected (mismatch between expected value of signal label and received value of signal label), the adaptation function shall generate an all-ONEs signal (AIS) in accordance with the relevant G.700-Series Recommendations.

Defect correlation

The function shall perform the following defect correlation to determine the most probable fault cause (see 2.2.4). This fault cause shall be reported to the SEMF.

cPLM ← dPLM and (not AI_TSF)

Performance monitoring

None.

7.3.2 *Sm*/User_A

The user channel byte F2 processing is for further study.

7.3.3 *Sm*/RFI_A

The processing of Remote Failure Indication (RFI) bit (V5 bit 4) is for further study.

7.4 Sublayer functions

7.4.1 Lower order path protection sublayer functions

Processes

Lower order VC trail protection switching is described in Recommendation G.841.

The *SmP*_C function provides protection for the lower order trail against channel-associated defects within a lower order trail from trail termination source to trail termination sink. The lower order trail protection sublayer is given in Figure 7-18. The sublayering is performed at the *Sm*_AP creating the *SmP* sublayer. The protection is performed in the sublayered connection point (*SmP*_CP).

The *SmP*_C functions at both ends operate the same way, by monitoring lower order VC-*m* [*m* = (11, 12, 2 or 3)] signals for defects, evaluating the system status taking into consideration the priorities of defect conditions and of external and remote switch requests, and selecting the signal from the appropriate path. The two *SmP*_C functions may communicate with each other via a bit-oriented protocol defined for the *SmP*_C characteristic information bytes [K3 (VC-3) or K4 (VC-2, 12, 11) byte in the POH of the protection path]. This protocol is described in Recommendation G.841.

The lower order trail protection function is explained in Figure 7-19. The working and protection lines are at the bottom.

7.4.1.1 Lower order path protection connection function (*SmP*_C)

The signal flow associated with the *SmP*_C function is described with reference to Figure 7-20 and Table 7-13. The *SmP*_C function receives control parameters and external switch requests at the *SmP*_C_MP reference point from the synchronous equipment management function and outputs status indicators at the *SmP*_C_MP to the synchronous equipment management function, as a result of switch commands described in Recommendation G.841.

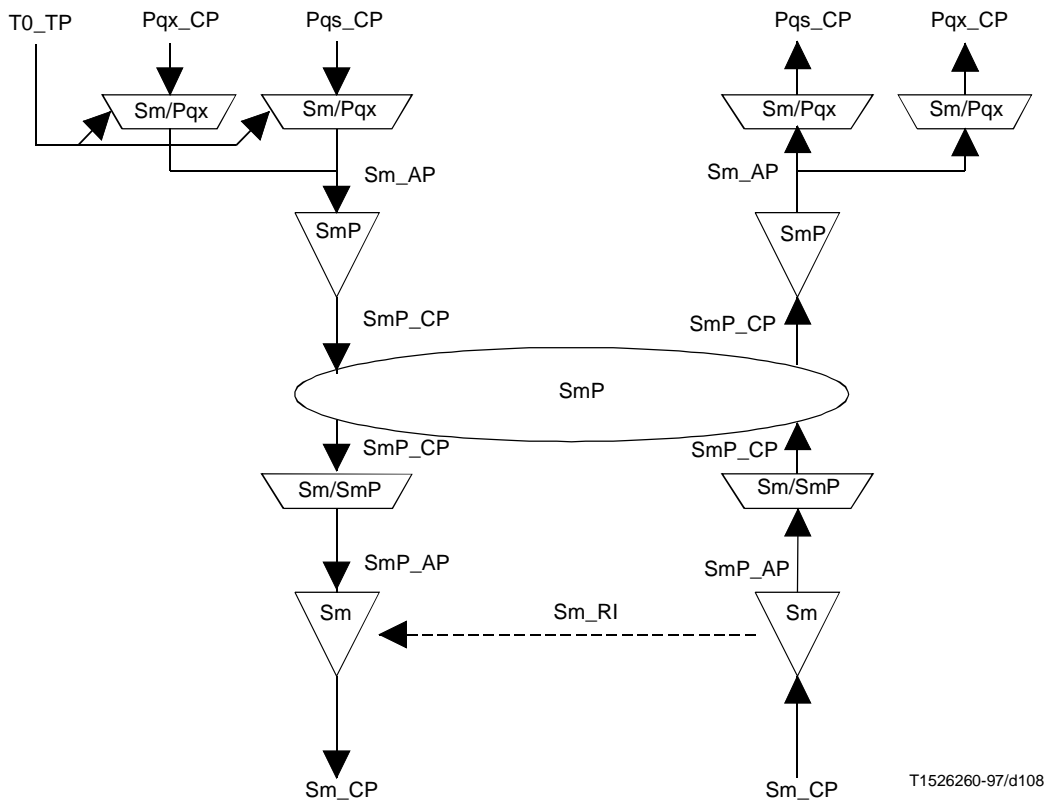

Figure 7-18/G.783 – Lower order path protection sublayer functions

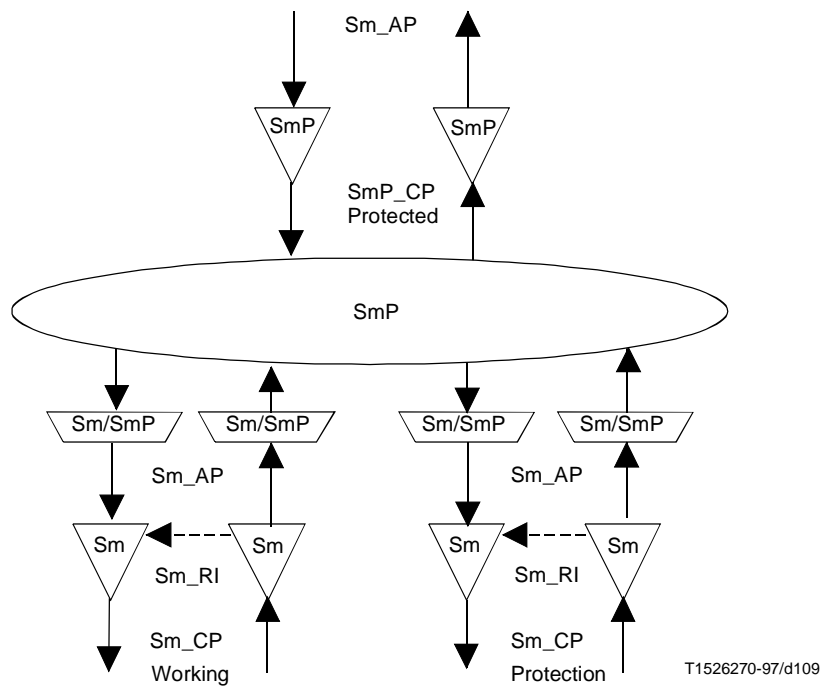

Figure 7-19/G.783 – Lower order path protection atomic functions

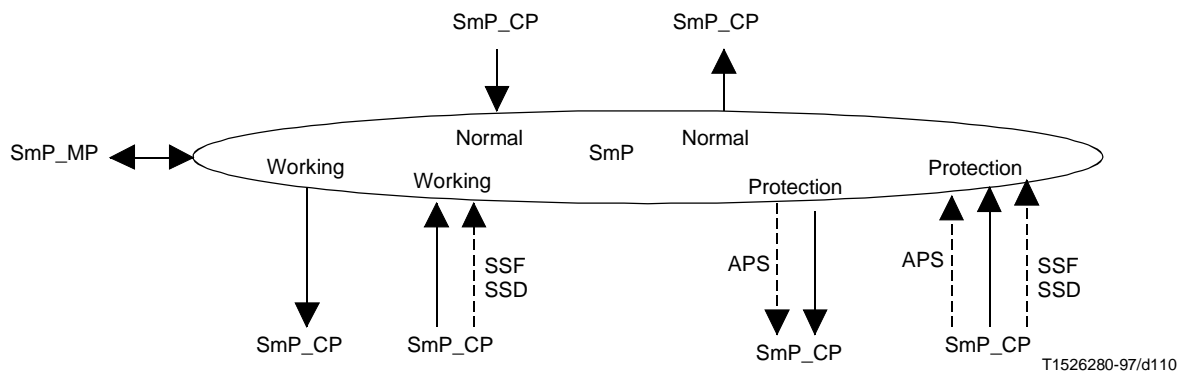

Figure 7-20/G.783 – Lower order path protection connection function

Interface

Table 7-13/G.783 – SmP_C input and output signals

Input(s)	Output(s)
For connection points W and P: <i>SmP_CI_Data</i> <i>SmP_CI_Clock</i> <i>SmP_CI_FrameStart</i> <i>SmP_CI_SSF</i> <i>SmP_CI_SSD</i>	For connection points W and P: <i>SmP_CI_Data</i> <i>SmP_CI_Clock</i> <i>SmP_CI_FrameStart</i>
For connection point N: <i>SmP_CI_Data</i> <i>SmP_CI_Clock</i> <i>SmP_CI_FrameStart</i>	For connection point N: <i>SmP_CI_Data</i> <i>SmP_CI_Clock</i> <i>SmP_CI_FrameStart</i> <i>SmP_CI_SSF</i>
For connection point P: <i>SmP_CI_APS</i>	For connection point P: <i>SmP_CI_APS</i>
<i>SmP_C_MI_OPERType</i> <i>SmP_C_MI_WTRTime</i> <i>SmP_C_MI_HOTime</i> <i>SmP_C_MI_EXTCMD</i>	<i>SmP_C_MI_pPSC</i> <i>SmP_C_MI_pPSSw</i> <i>SmP_C_MI_pPSSw</i>
	NOTE – Protection status reporting signals are for further study.

7.4.1.1.1 Source direction

Data at the *SmP_CP* is a lower order trail signal, timed from the *T0_TP* reference point, with indeterminate *Sm* layer POH bytes.

For 1 + 1 architecture, the signal received at the *SmP_CP* from the protection trail termination function (*SmP_TT_So*) is bridged permanently at the *SmP_CP* to both protection and working Protection trail termination (*SmP_TT_So*).

The APS information generated according to the rules in Recommendation G.841 are presented at the *SmP_CP* to the protection trail. This APS signal may also be presented to the working trails Protection trail termination (*SmP_TT_So*).

7.4.1.1.2 Sink direction

Framed lower order trail signals (data) *SmP_CI* whose lower order trail POH bytes have already been recovered by the *Sm_TT_Sk* are presented at the *SmP_CP* along with incoming timing references. The defect conditions SSF and SSD are also received at the *SmP_CP* from all *Sm_TT_Sk* functions.

The recovered APS information from the protection trail's adaptation function (*Sm/SmP_A_Sk*) is presented at the *SmP_CP*. Working trail's adaptation functions may also present these bytes to the *SmP_C*. The *SmP_C* must be able to ignore these bytes from the working adaptation functions.

Under normal conditions, *SmP_C* passes the data, timing, and signal fail from the working *Sm/SmP_A_Sk* functions to the corresponding *SmP_TT_Sk* functions at the *SmP_TCP*. The data and timing from the protection trail is not forwarded.

Under a fault condition on the working path, *SmP_C* passed the data, timing, and signal fail from the protection *Sm/SmP_A_Sk* function to the corresponding *SmP_TT_Sk* at the *SmP_TCP*. The signal received from the working *Sm/SmP_A_Sk* is not forwarded.

7.4.1.1.3 Switch initiation criteria

Automatic protection switching is based on the TSF and TSD conditions of the working and protection paths. Detection of these conditions is described in 7.2.1.2.

The protection switch can also be initiated by switch commands received via the synchronous equipment management function. See the switch criteria described in Recommendation G.841.

7.4.1.1.4 Switching time

Protection switching shall be completed within TBD ms of detection of an SSF or SSD condition that initiates a switch.

The protection switch completion time is for further study. A proposal is a basic switch time T_{bs} of TBD ms increased by a hold-off time T_{ho} provisionable from 0 to 10 s in steps of 100 ms.

7.4.1.1.5 Switch restoration

Switch restoration is a function related to revertive operation, when the working path has recovered from defect. It is not applicable to lower order trail protection which supports non-revertive operation only. See the description of revertive 1 + 1 unidirectional protection switching in Recommendation G.841.

Defects

None.

Consequent actions

None.

Defect correlation

None.

Performance monitoring

pPSC ← According to 2.2.5.6.

pPSSw ← According to 2.2.5.7.

pPSSp ← According to 2.2.5.7.

7.4.1.2 Lower order path protection trail termination (*SmP_TT*)

The Protection trail termination function comprises the atomic functions Protection trail termination source [*SmP_TT_So*, $m = (11, 12, 2 \text{ or } 3)$] and sink [*SmP_TT_Sk*, $m = (11, 12, 2 \text{ or } 3)$] as illustrated in Figure 7-21 and Tables 7-14 and 7-15.

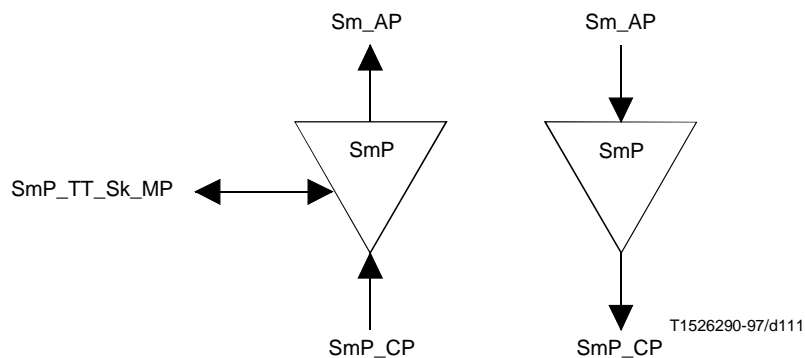

Figure 7-21/G.783 – Lower order path protection trail termination function

7.4.1.2.1 Source direction

Interfaces

Table 7-14/G.783 – *SmP_TT_So* input and output signals

Input(s)	Output(s)
<i>SmP_AI_Data</i> <i>SmP_AI_Clock</i> <i>SmP_AI_FrameStart</i>	<i>SmP_CI_Data</i> <i>SmP_CI_Clock</i> <i>SmP_CI_FrameStart</i>

Processes

No information processing is required in the *SmP_TT_So* since the *Sm_AI* at its output is identical to the *SmP_CI*.

Defects

None.

Consequent actions

None.

Defect correlation

None.

Performance monitoring

None.

7.4.1.2.2 Sink direction

Interfaces

Table 7-15/G.783 – *SmP_TT_Sk* input and output signals

Input(s)	Output(s)
<i>SmP_CI_Data</i> <i>SmP_CI_Clock</i> <i>SmP_CI_FrameStart</i> <i>SmP_CI_SSF</i>	<i>SmP_AI_Data</i> <i>SmP_AI_Clock</i> <i>SmP_AI_FrameStart</i> <i>SmP_AI_TSF</i> <i>SmP_TT_Sk_MI_cSSF</i>

Processes

The *SmP_TT_Sk* function reports, as part of the *Sm* layer, the state of the protected *Sm* trail. In case all trails are unavailable, the *SmP_TT_Sk* reports the signal fail condition of the protected trail.

Defects

None.

Consequent actions

aTSF ← CI_SSF

Defect correlation

cSSF ← CI_SSF

Performance monitoring

None.

7.4.1.3 Lower order path protection adaptation function (*Sm/SmP_A*)

See Figure 7-22.

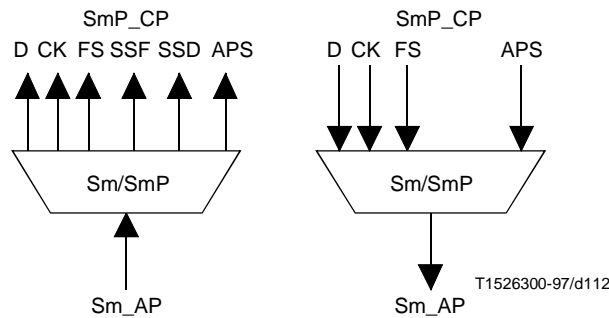

Figure 7-22/G.783 – Lower order trail protection adaptation function

7.4.1.3.1 Case of VC-11, 12 and 2

7.4.1.3.1.1 Source direction

Interfaces

See Table 7.16.

Table 7-16/G.783 – *Sm/SmP_A* So input and output signals

Input(s)	Output(s)
<i>SmP_AI_Data</i> <i>SmP_AI_Clock</i> <i>SmP_AI_FrameStart</i>	<i>SmP_CI_Data</i> <i>SmP_CI_Clock</i> <i>SmP_CI_FrameStart</i>

Processes

The function shall multiplex the *Sm* APS signal and *Sm* data signal onto the *Sm_AP*.

K4[1-4]: The insertion of the lower order APS signal is for further study. This process is required only for the protection trail.

Defects

None.

Consequent actions

None.

Defect correlation

None.

Performance monitoring

None.

7.4.1.3.1.2 Sink direction

Interfaces

See Table 7-17.

Table 7-17/G.783 – Sm/SmP_A_Sk input and output signals

Input(s)	Output(s)
<i>SmP_AI_Data</i> <i>SmP_AI_Clock</i> <i>SmP_AI_FrameStart</i> <i>SmP_AI_TSF</i> <i>SmP_SI_TSD</i>	<i>SmP_CI_Data</i> <i>SmP_CI_Clock</i> <i>SmP_CI_FrameStart</i> <i>SmP_CI_SSF</i> <i>SmP_CI_SSD</i> <i>SmP_CI_APS</i> (for protection signal only)

Processes

The function shall extract and output the *SmP_CI_D* signal from the *SmP_AI_D* signal.

K4[1-4]: The extraction and persistency processing of the lower order APS signal is for further study. This process is required only for the protection trail.

Defects

None.

Consequent actions

aSSF ← AI_TSF

aSSD ← AI_TSD

Defect correlation

None.

Performance monitoring

None.

7.4.1.3.2 Case of VC-3

The S3P_A functions are described in 6.4.1.

7.4.2 Lower order tandem connection sublayer functions

For the lower order VC-3 tandem connection functions, see 6.4.2.

7.4.2.1 Lower order tandem connection trail termination (SmD_TT)

This function acts as a source and sink for the lower order Tandem Connection OverHead (TCOH) described in Annex E/G.707 in case of VC-1/2. The information flows associated with the *SmD_TT* function are described with reference to Figure 7-23 and Tables 7-18 and 7-19.

The timing signal is provided from the SETS at the T0_TP reference point.

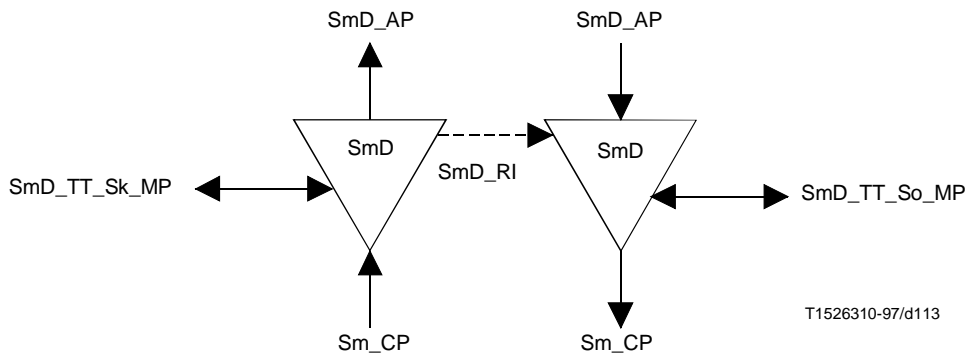

Figure 7-23/G.783 – Lower order tandem connection trail termination function

7.4.2.1.1 Source direction

Interface

Table 7-18/G.783 – *SmD_TT_So* input and output signals

Input(s)	Output(s)
<i>SmD_AI_Data</i> <i>SmD_AI_Clock</i> <i>SmD_AI_FrameStart</i> <i>SmD_AI_SF</i> <i>SmD_RI_RDI</i> <i>SmD_RI_REI</i> <i>SmD_RI_ODI</i> <i>SmD_RI_OEI</i> <i>SmD_TT_So_MI_TxTI</i>	<i>Sm_CI_Data</i> <i>Sm_CI_Clock</i> <i>Sm_CI_FrameStart</i>

Processes

N2[1-2]: The function shall calculate a BIP-2 over the *SmD_AP*, and insert this value in TC BIP-2 in the next frame (Figure 7-24).

N2[8][73]: The function shall insert the TC RDI code within 1 multiframe (38 ms) after the RDI request generation (*RI_RDI*) in the tandem connection trail termination sink function. It ceases RDI code insertion within 1 multiframe (38 ms) after the *RI_RDI* request has cleared.

N2[3]: The function shall insert a "1" in this bit.

N2[4]: The function shall insert an incoming AIS code in this bit. If *AI_SF* is true, this bit will be set to the value "1"; otherwise, value "0" shall be inserted.

N2[5]: The function shall insert the *RI_REI* value in the REI bit in the following frame.

N2[7][74]: The function shall insert the ODI code at the first opportunity after the ODI request generation (*RI_ODI*) in the sink direction. It ceases ODI code insertion at the first opportunity after the *RI_ODI* request has cleared.

N2[6]: The function shall insert the *RI_OEI* value in the OEI bit in the following frame.

N2[7-8]: The function shall insert in the multiframed N2[7-8] channel:

- the Frame Alignment Signal (FAS) "1111 1111 1111 1110" in FAS bits in frames 1 to 8;
- the TC trace identifier, received via reference point *SmD_TT_So_MP*, in the TC trace ID bits in frames 9 to 72;

- the TC RDI (N2[8][73]) and ODI (N2[7][74]) signals; and
- all-0s in the six reserved bits in frames 73 to 76.

V5[1-2]: The function shall compensate the VC-1/2 BIP-2 (in bits 1 and 2 of byte V5) as specified in 2.3.5.

Defects

None.

Consequent actions

None.

Defect correlation

None.

Performance monitoring

None.

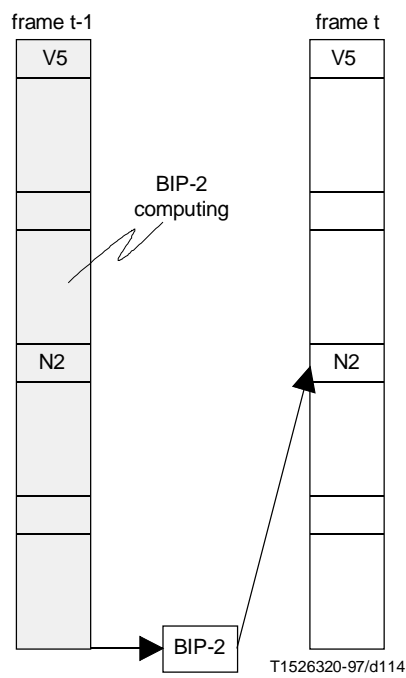

Figure 7-24/G.783 – TC BIP-2 computing and insertion

7.4.2.1.2 Sink direction

Interface

Table 7-19/G.783 – Smd_TT_Sk input and output signals

Input(s)	Output(s)
<i>Sm_CI_Data</i> <i>Sm_CI_Clock</i> <i>Sm_CI_FrameStart</i> <i>Sm_CI_SSF</i> <i>Smd_TT_Sk_MI_ExTI</i> <i>Smd_TT_Sk_MI_RDI_Reported</i> <i>Smd_TT_Sk_MI_ODI_Reported</i> <i>Smd_TT_Sk_MI_TIMdis</i> <i>Smd_TT_Sk_MI_DEGM</i> <i>Smd_TT_Sk_MI_DEGTHR</i> <i>Smd_TT_Sk_MI_1second</i> <i>Smd_TT_Sk_MI_TPmode</i>	<i>Smd_AI_Data</i> <i>Smd_AI_Clock</i> <i>Smd_AI_FrameStart</i> <i>Smd_AI_TSF</i> <i>Smd_AI_TSD</i> <i>Smd_AI_OSF</i> <i>Smd_RI_RDI</i> <i>Smd_RI_REI</i> <i>Smd_RI_ODI</i> <i>Smd_RI_OEI</i> <i>Smd_TT_Sk_MI_cLTC</i> <i>Smd_TT_Sk_MI_cTIM</i> <i>Smd_TT_Sk_MI_cUNEQ</i> <i>Smd_TT_Sk_MI_cDEG</i> <i>Smd_TT_Sk_MI_cRDI</i> <i>Smd_TT_Sk_MI_cODI</i> <i>Smd_TT_Sk_MI_AcTI</i> <i>Smd_TT_Sk_MI_pN_EBC</i> <i>Smd_TT_Sk_MI_pF_EBC</i> <i>Smd_TT_Sk_MI_pN_DS</i> <i>Smd_TT_Sk_MI_pF_DS</i> <i>Smd_TT_Sk_MI_pON_EBC</i> <i>Smd_TT_Sk_MI_pOF_EBC</i> <i>Smd_TT_Sk_MI_pON_DS</i> <i>Smd_TT_Sk_MI_pOF_DS</i>

Processes

N2[1-2]: See 2.3.6.

N2[7-8][9-72]: The Received Trail Trace Identifier shall be recovered from the tandem connection trail trace identifier overhead. The accepted value of TC trace identifier is also available at the *Smd_TT_MP*.

N2[4]: The function shall extract the Incoming AIS code.

N2[5], N2[8][73]: The information carried in the REI, RDI bits in byte N2 shall be extracted to enable single-ended maintenance of a bidirectional tandem connection Trail. The REI shall be used to monitor the error performance of the other direction of transmission, and the RDI shall be used to provide information as to the status of the remote receiver. A "1" indicates a Remote Defect Indication state, while a "0" indicates the normal, working state.

N2[6], N2[7][74]: The information carried in the OEI, ODI bits in byte N2 shall be extracted to enable single-ended (intermediate) maintenance of the VC-1/2 egressing the tandem connection Trail. The OEI (OF_B) shall be used to monitor the error performance of the other direction of transmission, and the ODI shall be used to provide information as to the status of the remote receiver. A "1" indicates an Outgoing Defect Indication state, while a "0" indicates the normal, working state.

N2[7-8]: Multiframe alignment: see 2.3.4.

V5[1-2]: Even BIP-2 is computed for each bit par of every byte of the preceding VC-1/2 including V5 and compared with bit N2 and 2 of V5 recovered from the current frame. A difference between the computed and recovered BIP-2 values is taken as evidence of one or more errors (ON_B) in the computation block.

N2: The function shall terminate N2 channel by inserting an all-ZEROs pattern.

V5[1-2]: The function shall compensate the VC-1/2 BIP-2 in bits 1 and 2 of byte V5 according to the algorithm defined in the source direction.

Defects

The function shall detect for dUNEQ, dLTC, dTIM, dDEG, dRDI, dODI, IncAIS defects according to the specification in 2.2.2.

Consequent actions

The function shall perform the following consequent actions (see 2.2.3):

aAIS	←	dUNEQ or dTIM or dLTC
aOSF	←	CI_SSF or dUNEQ or dTIM or dLTC or IncAIS
aTSF	←	CI_SSF or dUNEQ or dTIM or dLTC
aTSD	←	dDEG
aRDI	←	CI_SSF or dUNEQ or dTIM or dLTC
aREI	←	Σ nN_B
aODI	←	CI_SSF or dUNEQ or dTIM or IncAIS or dLTC
aOEI	←	Σ nON_B

The function shall insert the all-ONEs (AIS) signal within 1 ms after AIS request generation, and cease the insertion within 1 ms after the AIS request has cleared.

Defect correlation

The function shall perform the following defect correlation to determine the most probable fault cause (see 2.2.4). This fault cause shall be reported to the SEMF.

cUNEQ	←	dUNEQ and MON
cLTC	←	(not dUNEQ) and dLTC
cTIM	←	dTIM and (not dUNEQ) and (not dLTC) and MON
cDEG	←	dDEG and (not dTIM) and (not dLTC) and MON
cRDI	←	dRDI and (not dUNEQ) and (not dTIM) and (not dLTC) and MON and RDI_Reported
cODI	←	dODI and (not dUNEQ) and (not dTIM) and (not dLTC) and MON and ODI_Reported

Performance monitoring

The function shall perform the following performance monitoring primitives processing (see 2.2.5). The performance monitoring primitives shall be reported to the SEMF.

pN_DS	←	aTSF or dEQ
pF_DS	←	dRDI
pN_EBC	←	Σ nN_B
pF_EBC	←	Σ nF_B
pON_DS	←	aODI or dEQ
pOF_DS	←	dODI
pON_EBC	←	Σ nON_B
pOF_EBC	←	Σ nOF_B

7.4.2.2 Lower order tandem connection non-intrusive monitor function (*SmDm_TT*)

This function acts as a non-intrusive monitor for the lower order Tandem Connection OverHead (TCOH) described in Annex E/G.707 in case of VC-1/2.

The information flows associated with the *SmD/Sm_A* function are described with reference to Figure 7-25.

The timing signal is provided from the SETS at the T0_TP reference point.

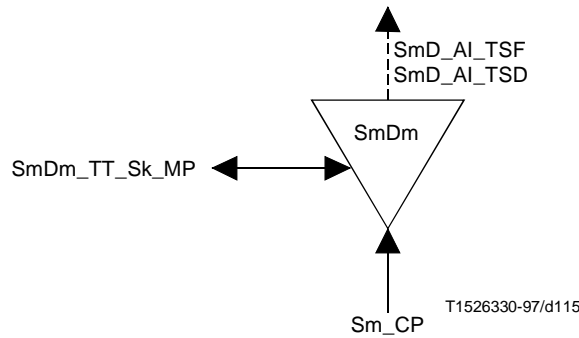

Figure 7-25/G.783 – Lower order tandem connection monitor function

This function can be used to perform the following:

- 1) single-ended maintenance of the TC by monitoring at an intermediate node, using remote information (RDI, REI);
- 2) aid in fault localisation within TC trail by monitoring near-end defects;
- 3) monitoring of VC performance at TC egressing point (except for connectivity defects before the TC) using remote outgoing information (ODI, OEI);
- 4) performing non-intrusive monitor function within SNC/S protection.

7.4.2.2.1 Sink direction

Interfaces

See Table 7-20.

Table 7-20/G.783 – SmDm_TT_Sk input and output signals

Input(s)	Output(s)
<i>Sm_CI_Data</i> <i>Sm_CI_Clock</i> <i>Sm_CI_FrameStart</i> <i>Sm_CI_SSF</i> <i>SmD_TT_Sk_MI_ExTI</i> <i>SmD_TT_Sk_MI_RDI_Reported</i> <i>SmD_TT_Sk_MI_ODI_Reported</i> <i>SmD_TT_Sk_MI_TIMdis</i> <i>SmD_TT_Sk_MI_DEGM</i> <i>SmD_TT_Sk_MI_DEGTHR</i> <i>SmD_TT_Sk_MI_1second</i> <i>SmD_TT_Sk_MI_TPmode</i>	<i>SmD_AI_TSF</i> <i>SmD_AI_TSD</i> <i>SmD_TT_Sk_MI_cLTC</i> <i>SmD_TT_Sk_MI_cTIM</i> <i>SmD_TT_Sk_MI_cUNEQ</i> <i>SmD_TT_Sk_MI_cDEG</i> <i>SmD_TT_Sk_MI_cRDI</i> <i>SmD_TT_Sk_MI_cODI</i> <i>SmD_TT_Sk_MI_AcTI</i> <i>SmD_TT_Sk_MI_pN_EBC</i> <i>SmD_TT_Sk_MI_pF_EBC</i> <i>SmD_TT_Sk_MI_pN_DS</i> <i>SmD_TT_Sk_MI_pF_DS</i> <i>SmD_TT_Sk_MI_pOF_EBC</i> <i>SmD_TT_Sk_MI_pOF_DS</i>

Processes

N2[1-2]: See 2.3.6.

N2[7-8][9-72]: The Received Trail Trace Identifier shall be recovered from the tandem connection trail trace identifier overhead. The accepted value of TC trace identifier is also available at the *SmDm_TT_MP*. The mismatch detection process shall be as specified below.

N2[4]: The function shall extract the Incoming AIS code.

N2[5], N2[8][73]: The information carried in the REI, RDI bits in byte N2 shall be extracted to enable single-ended maintenance of a bidirectional tandem connection Trail. The REI shall be used to monitor the error performance of the other direction of transmission, and the RDI shall be used to provide information as to the status of the remote receiver. A "1" indicates a Remote Defect Indication state, while a "0" indicates the normal, working state.

N2[6], N2[7][74]: The information carried in the OEI, ODI bits in byte N2 shall be extracted to enable single-ended (intermediate) maintenance of the VC-1/2 egressing the tandem connection Trail. The OEI (OF_B) shall be used to monitor the error performance of the other direction of transmission, and the ODI shall be used to provide information as to the status of the remote receiver. A "1" indicates an Outgoing Defect Indication state, while a "0" indicates the normal, working state.

N2[7-8]: see 2.3.4.

Defects

The function shall detect for dUNEQ, dLTC, dTIM, dDEG, dRDI, dODI, IncAIS defects according to the specification in 2.2.2.

Consequent actions

The function shall perform the following consequent actions (see 2.2.3):

aTSF ← CI_SSF or dUNEQ or dTIM or dLTC

aTSD ← dDEG

Defect correlation

The function shall perform the following defect correlation to determine the most probable cause (see 2.2.4). This fault cause shall be reported to the SEMF.

cUNEQ ← dUNEQ and MON

cLTC ← (not dUNEQ) and dLTC

cTIM ← (not dUNEQ) and (not dLTC) and dTIM and MON

cDEG ← (not dTIM) and (not dLTC) and dDEG and MON

cRDI ← (not dUNEQ) and (not dTIM) and (not dLTC) and dRDI and MON and RDI_Reported

cODI ← (not dUNEQ) and (not dTIM) and (not dLTC) and dODI and MON and ODI_Reported

Performance monitoring

The function shall perform the following performance monitoring primitives processing (see 2.2.5). The performance monitoring primitives shall be forwarded to the SEMF.

pN_DS ← aTSF or dEQ

pF_DS ← dRDI

pN_EBC ← Σ nM_B

pF_EBC ← Σ nF_B

pOF_DS ← dODI

pOF_EBC ← Σ nOF_B

7.4.2.3 Lower order tandem connection adaptation function (*SmD/Sm_A*)

This function acts as a source and sink for the adaptation of LO *Sm* layer to LO *SmD* sublayer. This function is applicable for networks that support the lower order tandem connection monitoring protocol option 2 described in Annex E/G.707 in case of VC-1/2.

The information flows associated with the *SmD/Sm_A* function are described with reference to Figure 7-26 and Tables 7-21 and 7-22.

The timing signal is provided from the SETS at the T0_TP reference point.

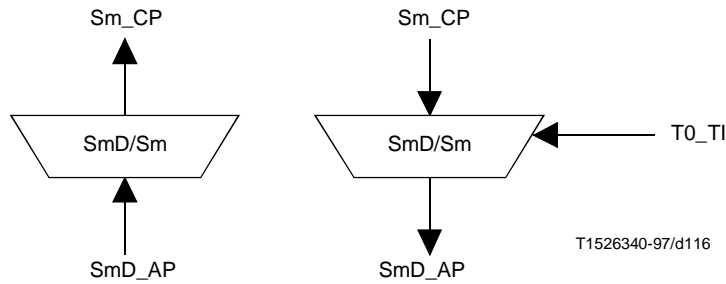

Figure 7-26/G.783 – Lower order tandem connection adaptation function

7.4.2.3.1 Source direction

Interfaces

Table 7-21/G.783 – SmD/Sm_A_So input and output signals

Input(s)	Output(s)
<i>Sm_CI_Data</i> <i>Sm_CI_Clock</i> <i>Sm_CI_FrameStart</i> <i>Sm_CI_SSF</i> <i>T0_TI_Clock</i>	<i>SmD_AI_Data</i> <i>SmD_AI_Clock</i> <i>SmD_AI_FrameStart</i> <i>SmD_AI_SF</i>

Processes

NOTE 1 – The function has no means to verify the existence of a tandem connection within the incoming signal. Nested tandem connections are not supported.

The function shall replace the incoming Frame Start signal by a local generated one (i.e. enter "holdover") if an all-ONEs (AIS) VC is received (i.e. this function replaces an all-ONEs incoming VC by a VC-AIS signal).

NOTE 2 – This replacement of the (invalid) incoming frame start signal results in the generation of a valid pointer in the *Sn/Sm_A_So* function.

Defects

None.

Consequent actions

This function shall perform the following consequent actions:

aSSF ← CI_SSF

Defect correlation

None.

Performance monitoring

None.

7.4.2.3.2 Sink direction

Interfaces

Table 7-22/G.783 – SmD/Sm_A_Sk input and output signals

Input(s)	Output(s)
<i>SmD_AI_Data</i> <i>SmD_AI_Clock</i> <i>SmD_AI_FrameStart</i> <i>SmD_AI_OSF</i>	<i>Sm_CI_Data</i> <i>Sm_CI_Clock</i> <i>Sm_CI_FrameStart</i> <i>Sm_CI_SSF</i>

Processes

The function shall restore the invalid frame start condition (i.e. output aSSF = true) if that existed at the ingress of the tandem connection.

NOTE 1 – In addition, the invalid frame start condition is activated on a tandem connection connectivity defect condition that causes all-ONEs (AIS) insertion in the *SmD_TT*.

Defects

None.

Consequent actions

aAIS ← AI_OSF

aSSF ← AI_OSF

NOTE 2 – CI_SSF = true will result in TU-AIS generation by *SmD/Sm_A_Sk* function.

The function shall insert the all-ONEs (AIS) signal within 1 ms after AIS request generation, and cease the insertion within 1 ms after the AIS request has cleared.

Defect correlation

None.

Performance monitoring

None.

8 Compound functions

Compound functions are currently characterized in terms of basic functions, which were predominately used in earlier versions of Recommendation G.783. Further work is needed to characterize the compound functions in terms of atomic functions. For the time being, it is necessary to use the tables at the beginning of clauses 3 through 7 to relate the basic functions to atomic functions.

8.1 Transport Terminal Function (TTF)

The Transport Terminal Function comprises as a compound function the basic functions SDH Physical Interface (SPI), Regenerator Section Termination (RST), Multiplex Section Termination (MST), Multiplex Section Protection (MSP) and Multiplex Section Adaptation (MSA) as illustrated in Figure 8-1. The basic and corresponding atomic functions and the information flows across their reference points are described in clauses 3, 4, and 5.

NOTE – The MSP function enables protection switching of multiplex sections. Since it has the identical information flows at the reference points at both sides, it may be optional or degenerate.

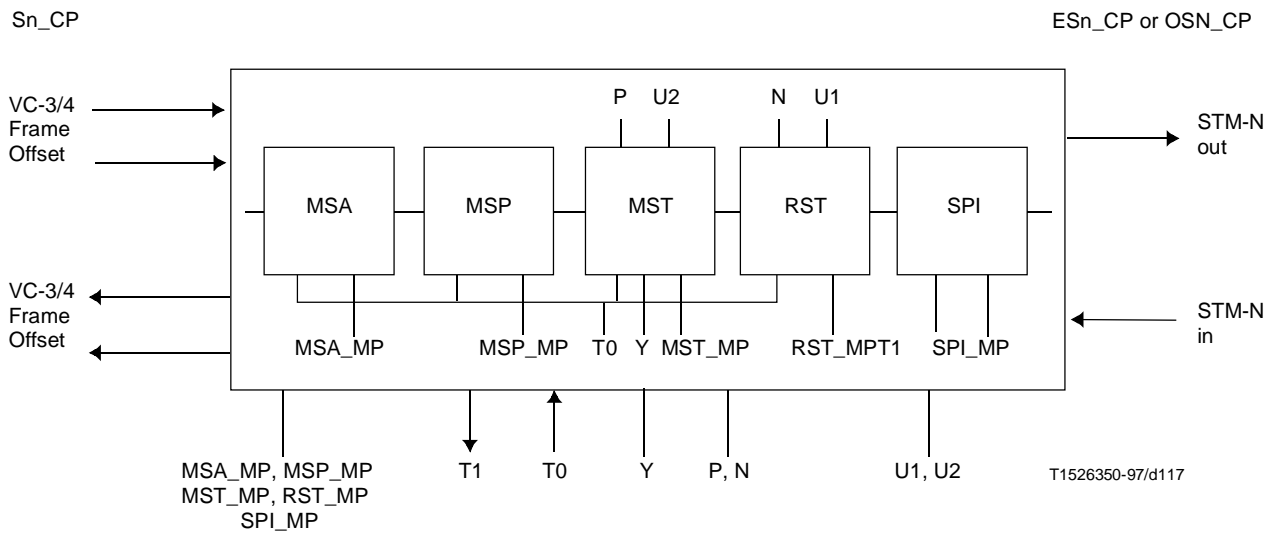

Figure 8-1/G.783 – Transport terminal function

8.2 Higher Order Interface (HOI)

The Higher Order Interface function comprises as a compound function the basic functions PDH Physical Interface (PPI), Lower order Path Adaptation (LPA) and Higher order Path Termination (HPT) as illustrated in Figure 8-2. The basic and corresponding atomic functions and the information flows across their reference points are described in clause 6.

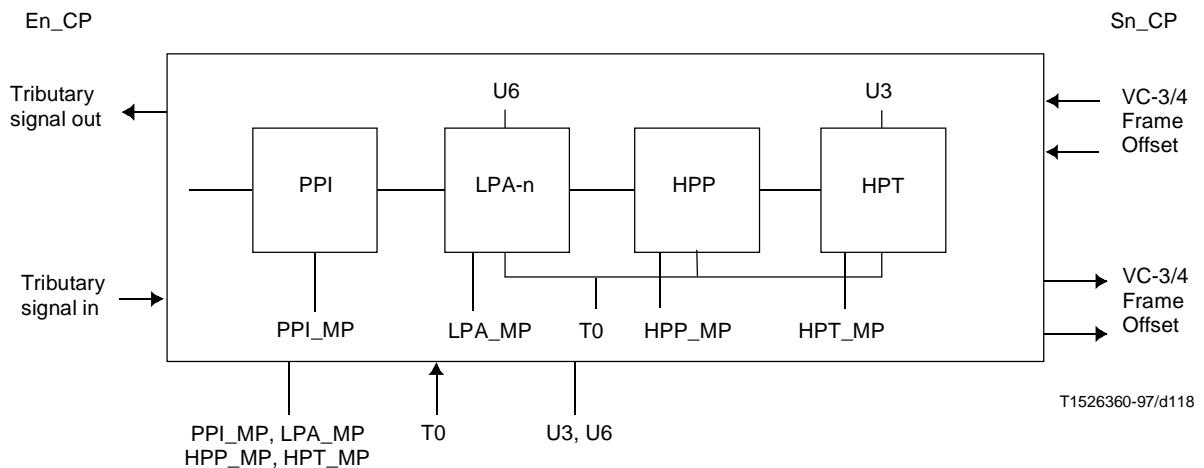

Figure 8-2/G.783 – Higher order interface function

8.3 Lower Order Interface (LOI)

The Lower Order Interface function comprises as a compound function the basic functions PDH Physical Interface (PPI), Lower order Path Adaptation (LPA) and Lower order Path Termination (LPT) as illustrated in Figure 8-3. The basic and corresponding atomic functions and the information flows across their reference points are described in clause 7.

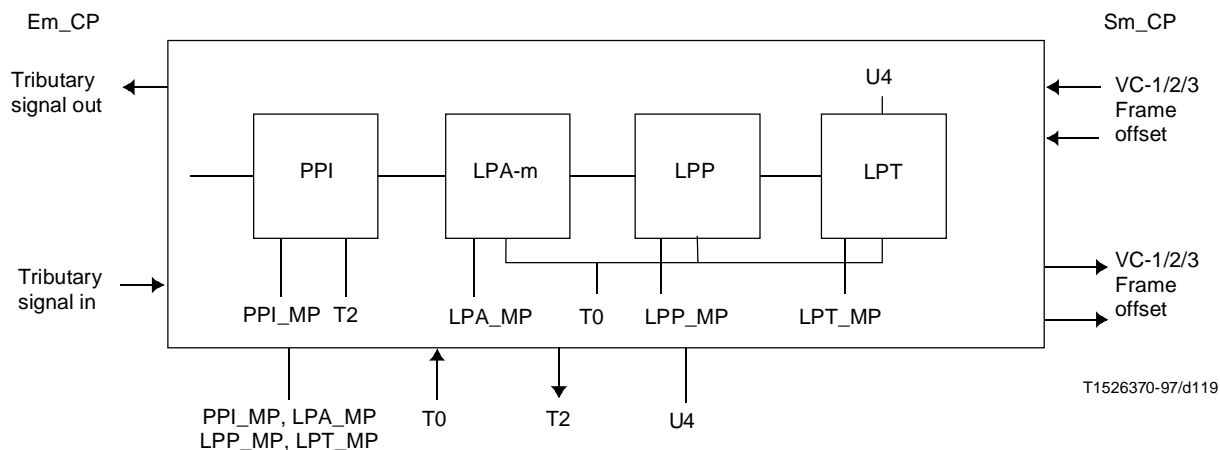

Figure 8-3/G.783 – Lower order interface function

8.4 Higher Order Assembler (HOA)

The Higher Order Assembler function comprises as a compound function the basic functions Higher order Path Adaptation (HPA) and Higher order Path Termination (HPT) as illustrated in Figure 8-4. The basic and corresponding atomic functions and the information flows across their reference points are described in clause 6.

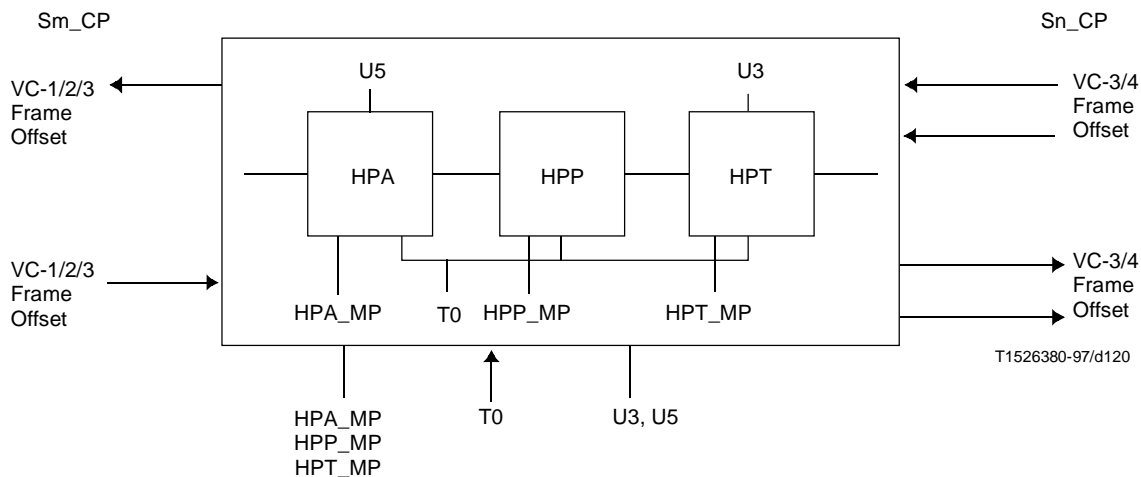

Figure 8-4/G.783 – Higher order assembler function

9 Timing functions

9.1 Synchronous Equipment Timing Source (SETS) function

This function provides timing reference to all functional blocks except the SPI, PPI, SEMF, MCF, and OHA. The Synchronous Equipment Timing Source (SETS) function represents the SDH network element clock. The SETS function includes an internal oscillator function and Synchronous Equipment Timing Generator (SETG) function. The information flows associated with the SETS function are described with reference to Figure 9-1.

The synchronization source may be selected from any of the reference points T1, T2, T3:

- T1 derived from STM-N input signal.
- T2 derived from PDH input signal.
- T3 derived from external synchronization reference signal.

When the SETS is synchronized to a signal carrying a network frequency reference standard, the short-term stability requirements at the T0 and T4 reference points are specified in Recommendations G.812 and G.813.

Loss of all incoming timing references (LTI) (T1, T2 and T3) shall be reported to the SEMF at reference point SETS_MP.

NOTE 1 – The synchronization distribution model is defined in Recommendation G.803.

NOTE 2 – Figure 9-1 represents a functional block diagram which requires further decomposition to align with Recommendation G.803. This topic is for further study.

NOTE 3 – SSM processing is for further study within ITU-T SG 13.

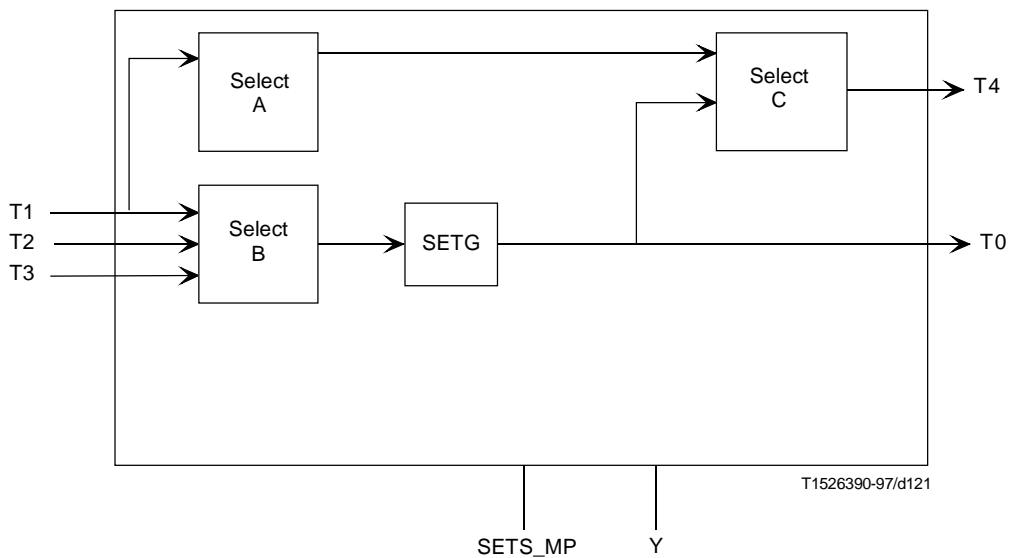

SETG Synchronous Equipment Timing Generator function

NOTE 1 – There may be more than one signal at T1, T2 or T3 reference points.

NOTE 2 – The SETG may be replicated.

NOTE 3 – Selection criteria for selectors A and B are for further study.

NOTE 4 – Selector C is provisioned by external commands.

NOTE 5 – Criteria for squelching, i.e. inhibiting the signal, are for further study.

Figure 9-1/G.783 – Synchronous equipment timing source function

9.1.1 Selector A

This function selects one reference synchronization source from a number of signals on T1 reference point derived from STM-N signals.

9.1.2 Selector B

This function selects one reference synchronization source from a number of signals on T1, T2 (derived from input PDH signal) and T3 (derived from external reference synchronization signal).

9.1.3 Synchronous Equipment Timing Generator (SETG)

The SETG function contains a clock of either G.812 or G.813 characteristics. It operates in the following modes, as defined in Recommendation G.810:

- locked to input reference source selected by selector B;
- holdover mode;
- free run mode.

The SETG provides filtering functions to ensure compliance with the requirements of Recommendation G.812 or G.813.

9.1.4 Selector C and squelching

This function is activated by an operator command. It selects either T0 or T1 as selected by selector A.

The squelching function is provisioned by the operator to disable T4. The criteria for the squelching function are for further study.

9.2 Synchronous Equipment Timing Physical Interface (SETPI) function

This function provides the interface between the external synchronization signal and the synchronous equipment timing source and shall have, at the synchronization interface port, the physical characteristics of one of the G.703 (PDH) synchronization interfaces (see Figure 9-2). The 2048 kHz synchronization interface port shall be according to clause 10/G.703.

NOTE – The frequency tolerance of this synchronization signal is constrained by the requirements of the client layer; e.g. for SDH equipment the client layer is specified in Recommendation G.812 or G.813. The case of 1544 kHz is for further study.

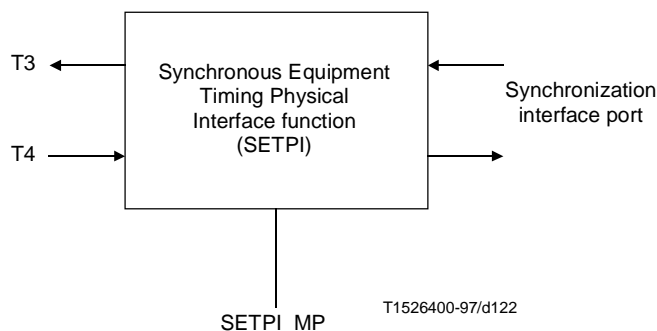

Figure 9-2/G.783 – Synchronous equipment physical interface

The SETPI monitors the signal from the synchronization port and reports a LOS condition on that port to the reference point SETPI_MP.

Defect correlations

cLOS ← dLOS

9.2.1 Signal flow from T4 to synchronization interface

This signal flow only exists if the SETS can provide external synchronization.

The functions performed by the SETPI are the encoding and adaptation to the physical medium.

The SETPI function takes timing at reference point T4 from the SETS to form the transmit synchronization signal. The SETPI passes the timing information to the synchronization interface transparently.

9.2.2 Signal flow from synchronization interface to T3

The SETPI function extracts timing from the received synchronization signal. After decoding, it passes timing information to the SETS.

10 Specification of jitter and wander

SDH jitter and wander is specified at both STM-N and G.703 (PDH) interfaces. The SDH equipment's jitter and wander characteristics at such interfaces may be categorized in terms of whether:

- its jitter and wander performance is governed exclusively by the input timing extraction circuitry;
- tributary bit justification is performed in addition to input timing extraction;
- phase smoothing of pointer justifications is performed as well as tributary bit justification and input timing extraction.

In addition, the wander encoded in both the AU and TU pointer adjustments is specified. (This determines the statistics of occurrence of pointer adjustments.)

10.1 STM-N interfaces

10.1.1 Input jitter and wander tolerance

Jitter present on the STM-N signal must be accommodated by the SPI. The detailed parameters and limits for optical line systems are specified in Recommendation G.958. Jitter tolerance requirements for STM-N interfaces are specified in Recommendation G.825.

The STM-N signal may be used to synchronize the Synchronous Equipment Timing Source (SETS), which must be able to accommodate the maximum absolute jitter and wander present on the STM-N signal. This will be primarily affected by wander, and can be specified in terms of Maximum Time Interval Error (MTIE). The detailed parameters and limits are specified in Recommendation G.813.

10.1.2 Output jitter and wander generation

The output jitter and wander must meet the short-term stability requirements specified in Table 6/G.813 or Table 7/G.813.

When the synchronous equipment timing source is used, the output jitter and wander depends on the inherent properties of the synchronous equipment timing generator as well as the properties of the synchronization input.

When the equipment is loop-timed, the output jitter and wander depends on the incoming jitter and wander as filtered by the jitter and wander transfer characteristics described in 10.1.3.

Further requirements for wander are specified in Recommendation G.813 in terms of MTIE, together with its first and second derivatives with respect to time. Requirements for output jitter are specified in Recommendation G.813.

10.1.3 Jitter and wander transfer

The jitter and wander transfer is dependent on whether the equipment is synchronized and the manner in which it is synchronized.

When the equipment is not synchronized, the jitter and wander transfer characteristics have no meaning as the output jitter and wander is determined solely by the internal oscillator.

When the equipment is synchronized, the jitter and wander transfer characteristics are determined by the filtering characteristics of the Synchronous Equipment Timing Generator (SETG). These filtering characteristics may vary depending on whether the equipment is loop-timed or uses a synchronous equipment timing source. Figure 10-1 provides a block diagram of timing functions for SDH equipment using loop timing.

The jitter transfer characteristics (specifically, the ratio of the output jitter to the applied input jitter as a function of frequency) can be tested using sinusoidal input jitter. It should be noted that this may not adequately test some non-linear timing generator implementations. The introduction of some new tests based on broadband jitter may help to characterize such implementations.

The detailed parameters and limits are specified in Recommendation G.813.

10.1.4 Transfer of wander encoded in AU and TU pointer adjustments

The transfer of wander encoded in the AU and TU pointer adjustments is controlled by the AU and TU pointer processors, respectively. Wander is affected by the difference between the incoming phase and the fill within the pointer processor buffer. The larger the buffer spacing, the less likely that incoming pointer adjustments will result in outgoing pointer adjustments.

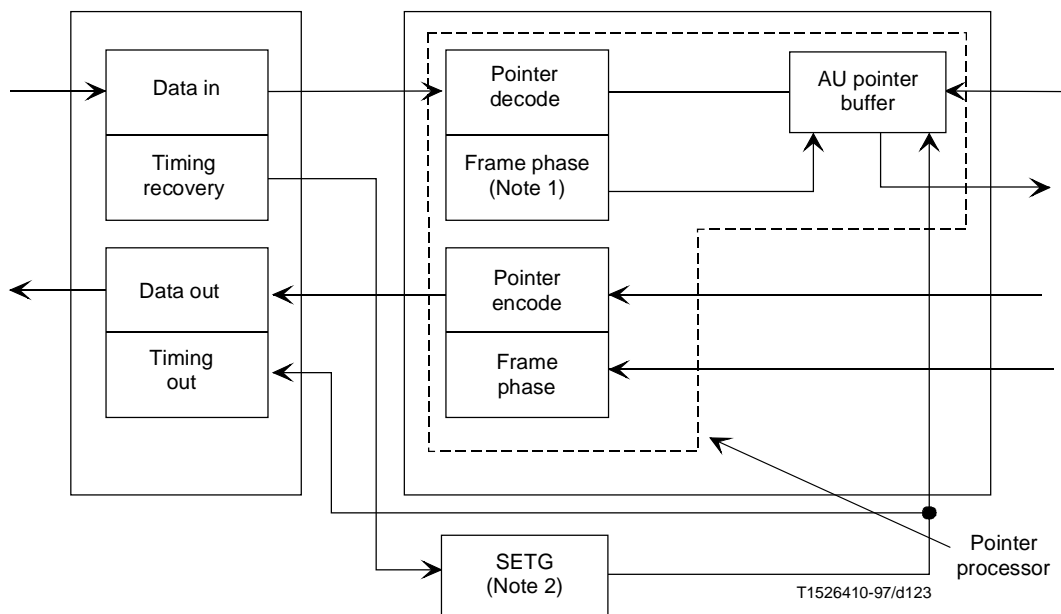

NOTE 1 – This element provides both frame phase and gapped clock to be buffer.

NOTE 2 – The characteristics of this synchronous equipment timing generator may be different from those used in a SETS.

Figure 10-1/G.783 – Block diagram of timing functions for synchronous equipment using loop timing

10.1.4.1 AU pointer processor buffer threshold spacing

The MTIE of the higher-order VC with respect to the clock generating the STM-N frame is quantized and encoded in the AU pointer. When a higher-order VC is transferred from an STM-N to another STM-N derived from a different clock, the AU pointer must be processed. The pointer is first decoded to derive the frame phase and a clock to write to the AU pointer processor buffer. The read clock from the buffer is derived from the synchronous equipment timing source. The buffer fill is monitored and when upper or lower thresholds are crossed, the frame phase is adjusted.

The allocation in the pointer processor buffer for pointer hysteresis threshold spacing should be at least 12 bytes for AU-4 and at least 4 bytes for AU-3 [corresponding to maximum relative time interval error (MRTIE) of 640 ns between reference point T0 and the incoming STM-N line signal].

10.1.4.2 TU pointer processor buffer threshold spacing

The MTIE of the lower-order VC with respect to the clock generating the higher-order VC is quantized and encoded in the TU pointer. When a lower-order VC is transferred from one higher-order VC into another higher-order VC derived from a different clock, the TU pointer must be processed. The pointer is first decoded to derive the frame phase and a clock to write to the TU pointer processor buffer. The read clock from the buffer is derived from the synchronous equipment timing source. The buffer fill is monitored and when upper or lower thresholds are crossed, the frame phase is adjusted.

The allocation in the pointer processor buffer for pointer hysteresis threshold spacing should be at least 4 bytes for TU-3s and at least 2 bytes for TU-1s and TU-2s.

10.2 PDH interfaces

10.2.1 Input jitter and wander tolerance

Input jitter and wander tolerance for 2048 kbit/s hierarchy based signals are specified in Recommendation G.823. Input jitter and wander tolerance of 1544 kbit/s hierarchy based signals are specified in Recommendations G.824, G.743, and G.752. The PDH signal may be used to synchronize the Synchronous Equipment Timing Source (SETS). In this case, additional parameters and limits are specified in Recommendation G.813.

NOTE – It may be necessary to specify transmit and receive separately for multi-vendor systems.

10.2.2 Jitter and wander transfer

As a minimum requirement, the jitter transfer specifications in any corresponding plesiochronous equipment Recommendations must be met.

NOTE 1 – Equipment jitter and wander transfer may be difficult to specify for multi-vendor systems. Desynchronizers jitter and wander transfer may be more amenable to specification.

NOTE 2 – The above-mentioned specifications are not sufficient to assure that SDH equipment provide adequate overall jitter and wander attenuation. Specifically, attenuation of the jitter and wander arising from decoded pointer adjustments places more stringent requirements on the SDH desynchronizer transfer characteristic.

10.2.3 Jitter and wander generation

10.2.3.1 Jitter and wander from tributary mapping

Specifications for jitter arising from mapping G.703 (PDH) tributaries into containers, described in Recommendation G.707, should be specified in terms of peak-to-peak amplitude over a given frequency band over a given measurement interval. Detailed specifications are for further study. The limits for each G.703 (PDH) tributary interface and the corresponding filter characteristics for mapping jitter are given in Table 10-1.

NOTE – Tributary mapping jitter is measured in the absence of pointer adjustments. The output jitter from a 2048 kbit/s synchronizer, in the absence of input jitter and pointer activity, shall not exceed 0.35 UI peak-to-peak when measured through a digital 10 Hz low-pass filter (representing an ideal desynchronizer) followed by a measurement filter which has a high-pass corner frequency of 20 Hz and a 20 dB/decade slope.

The output wander should be specified in terms of MTIE together with its first and second derivatives with respect to time. The need for and details of this specification are for further study.

10.2.3.2 Jitter and wander from pointer adjustments

The jitter and wander arising from decoded pointer adjustments must be sufficiently attenuated to ensure that existing plesiochronous network performance is not degraded. Detailed specifications are for further study.

10.2.3.3 Combined jitter and wander from tributary mapping and pointer adjustments

The combined jitter arising from tributary mapping and pointer adjustments should be specified in terms of peak-to-peak amplitude over a given frequency band, under application of representative specified pointer adjustment test sequences, for a given measurement interval. This interval is dependent on the test sequence duration and number of repetitions. A key feature that must be considered in the specification of the effects of pointer adjustments on G.703 (PDH) interfaces

is the demarcation between jitter and wander. Thus, a critical feature is the high-pass filter characteristics. The limits for each G.703 (PDH) tributary interface and the corresponding filter characteristics for combined jitter are given in Table 10-2, based on the pointer test sequences shown in Figure 10-2.

In order to prime the pointer processor and to prepare the equipment for the test sequence, it is necessary to apply initialization and cool-down sequences. In the case of single and burst sequences, the pointer processor must not absorb the pointer movements and stop them affecting the jitter on the demultiplexed tributary signal. In the case of periodic sequences, the pointer processor must be in the steady-state condition that it would be in if continual pointer movements had always been present. For single and burst test sequences, the initialization period should consist of pointer adjustments applied at a rate exceeding that of the test sequence, but less than 3 pointer adjustments per second, in the same direction as the subsequent test sequence. The initialization period should last, at least, until a response is detected in the jitter measured on the demultiplexed tributary signal. After the initialization period, it is recommended that a 30-second cool-down period is allowed when no pointer activity is present in the test signal. For periodic test sequences (both continuous and gapped), it is recommended that a minimum 60-second initialization period be used. A 30-second cool-down period is recommended during which the periodic sequence is applied so that a steady state condition is maintained. If necessary, the period must be extended to include an integral number of complete sequences.

Two tests for wander may be necessary: one with a single pole HPF and another with a double pole high-pass filter in order to differentiate between the first and second derivatives of MTIE. Detailed specifications are for further study.

The values in Tables 10-1 and 10-2 are only valid if all network elements providing the path are maintained in synchronization. The above requirements do not apply under network synchronization loss conditions.

Table 10-1/G.783 – Mapping jitter generation specification

G.703 (PDH) interface	Filter characteristics (Note 3)			Maximum peak-to-peak jitter	
				Mapping	
	f1 high pass	f3 high pass	f4 low pass	f1-f4	f3-f4
1 544 kbit/s	10 Hz 20 dB/dec	8 kHz	40 kHz -20 dB/dec	(Note 1)	0.1 UI
2 048 kbit/s	20 Hz 20 dB/dec	18 kHz (700 Hz) 20 dB/dec	100 kHz -20 dB/dec	(Note 1)	0.075 UI
6 312 kbit/s	10 Hz	3 kHz	60 kHz -20 dB/dec	(Note 1)	0.1 UI
34 368 kbit/s	100 Hz 20 dB/dec	10 kHz 20 dB/dec	800 kHz -20 dB/dec	(Note 1)	0.075 UI
44 736 kbit/s	10 Hz	30 kHz	400 kHz -20 dB/dec	0.40 UI (A ₀)	0.1 UI
139 264 kbit/s	200 Hz 20 dB/dec	10 kHz 20 dB/dec	3500 kHz -20 dB/dec	(Note 1)	(Note 2)
NOTE 1 – These values are for further study.					
NOTE 2 – For further study. A value of 0.075 UI has been proposed.					
NOTE 3 – The frequency value shown in parenthesis only applies to certain national interfaces.					

Table 10-2/G.783 – Combined jitter generation specification

G.703 (PDH) interface	Filter characteristics (Note 5)			Maximum peak-to-peak jitter	
				Combined	
	f1 high pass	f3 high pass	f4 low pass	f1-f4	f3-f4
1 544 kbit/s	10 Hz 20 dB/dec	8 kHz	40 kHz –20 dB/dec	1.5 UI (Note 6)	(Note 1) (Note 6)
2 048 kbit/s	20 Hz 20 dB/dec	18 kHz (700 Hz) 20 dB/dec	100 kHz –20 dB/dec	0.4 UI (Note 2)	0.075 UI (Note 2)
6 312 kbit/s	10 Hz	3 kHz	60 kHz –20 dB/dec	1.5 UI (Note 6)	(Note 1) (Note 6)
34 368 kbit/s	100 Hz 20 dB/dec	10 kHz 20 dB/dec	800 kHz –20 dB/dec	0.4 UI 0.75 UI (Note 3)	0.075 UI (Note 3)
44 736 kbit/s	10 Hz	30 kHz	400 kHz –20 dB/dec	(Note 1) (Note 7)	(Note 1) (Note 7)
139 264 kbit/s	200 Hz 20 dB/dec	10 kHz 20 dB/dec	3500 kHz –20 dB/dec	(Note 4) (Note 8)	(Note 4) (Note 8)

NOTE 1 – These values are for further study.

NOTE 2 – The limit corresponds to pointer sequences in Figure 10-2 a), b), c). $T_2 \geq 0.75$ $T_3 = 2$ ms.

NOTE 3 – The 0.4 UI and 0.075 UI limits correspond to pointer sequences in Figure 10-2 a), b), c). The 0.75 UI limit corresponds to the pointer sequence in Figure 10-2 d). T_2 and T_3 values are for further study. It is assumed that pointer adjustments of opposite polarities are well spread in time, i.e. the periods between adjustments are greater than the desynchronizer time constant.

NOTE 4 – For further study. Values according to Note 3 have been proposed.

NOTE 5 – The frequency value shown in parenthesis only applies to certain national interfaces.

NOTE 6 – The limit corresponds to pointer sequences in Figure 10-2 e), f), g), and h) when a VC-11 or VC-2 mapping is used. $T_4 = 2$ ms, 1 s $< T_5 < 10$ s.

NOTE 7 – The limit corresponds to pointer sequences in Figure 10-2 e), f), g), and h) when an AU-3 mapping is used. $T_4 = 0.5$ ms, 34 ms $\leq T_5 < 10$ s.

NOTE 8 – The pointer sequence in Figure 10-2 g) applies at AU-3 and AU-4 levels only. Jitter and wander values are for further study.

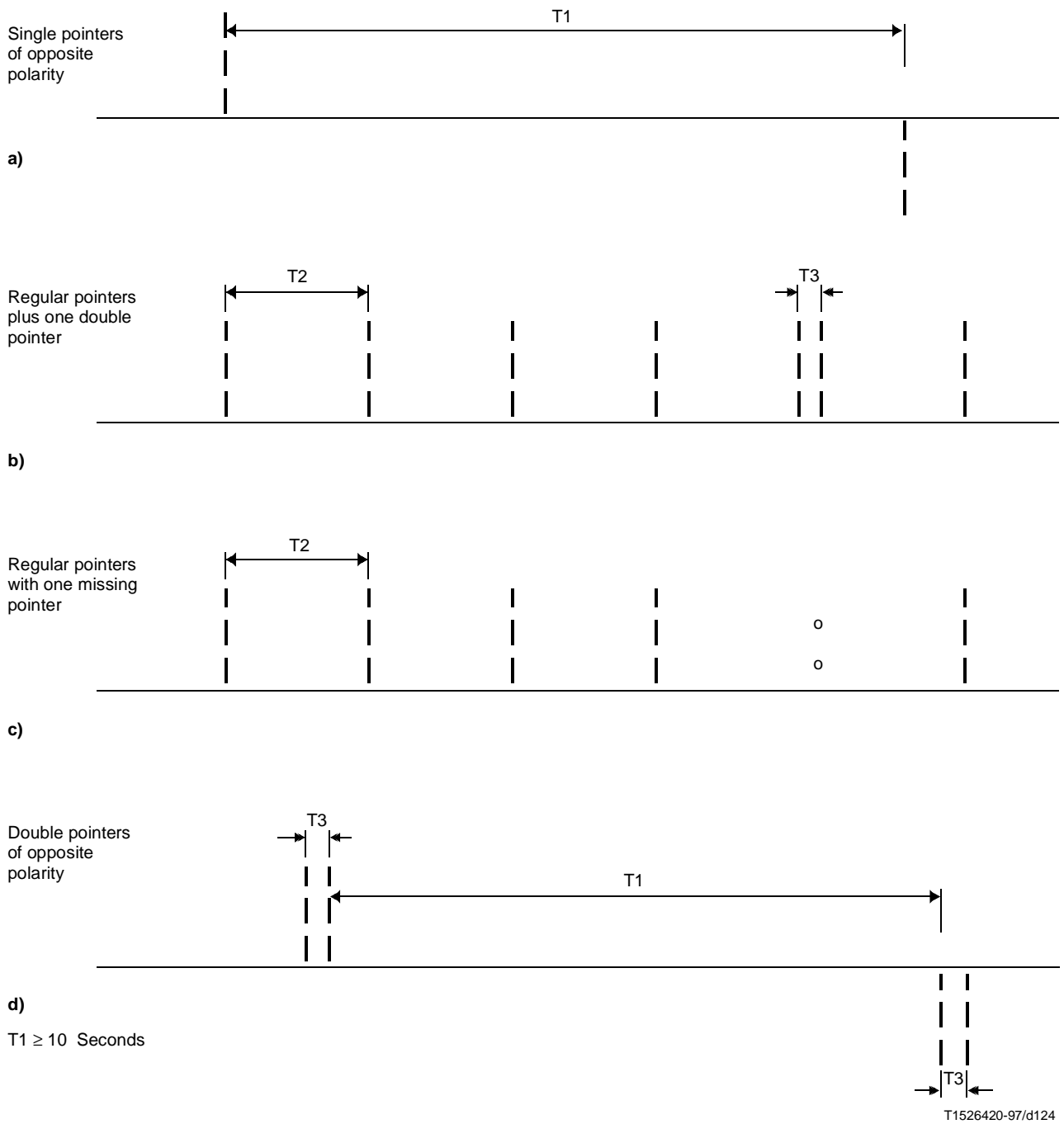
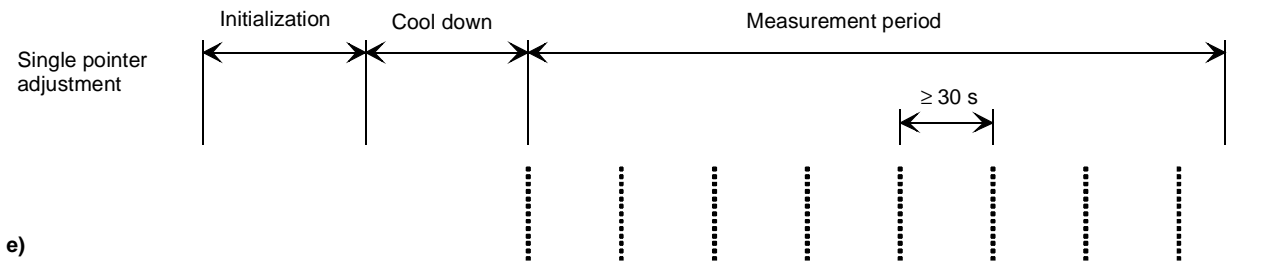
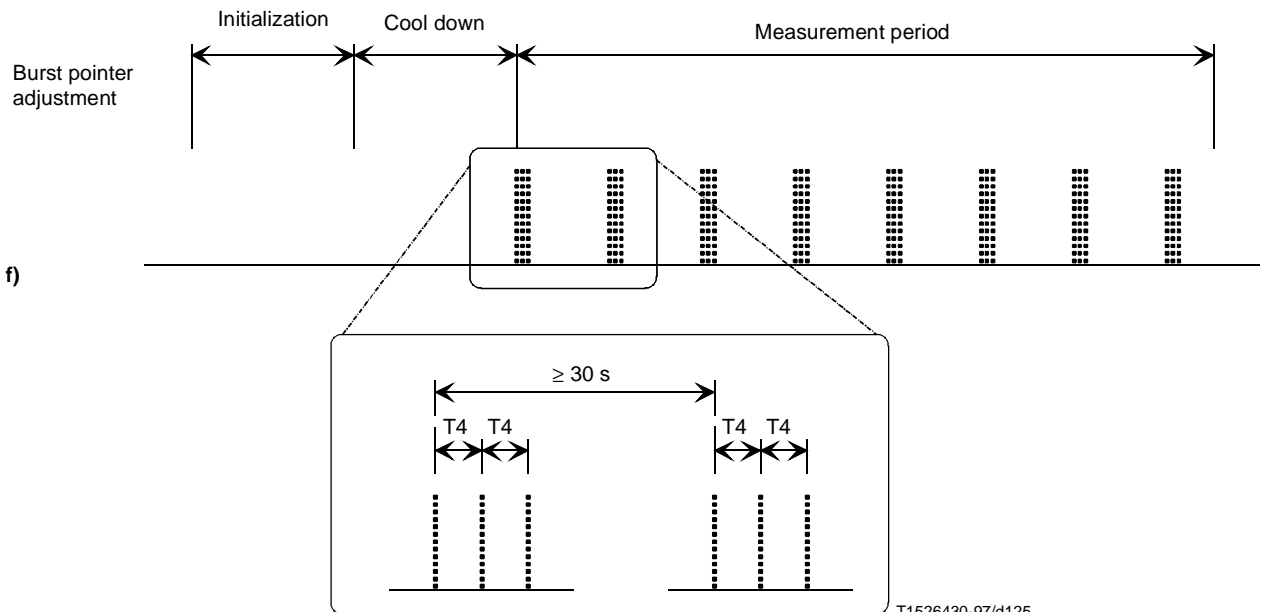

Figure 10-2/G.783 – Pointer test sequences



e)



f)

T1526430-97/d125

Figure 10-2/G.783 – Pointer test sequences (continued)

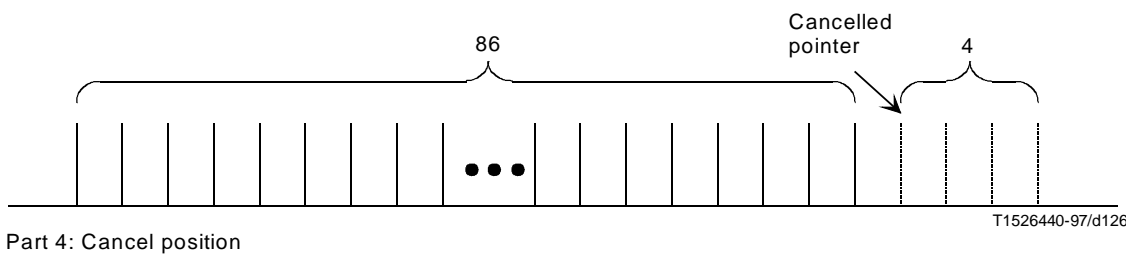
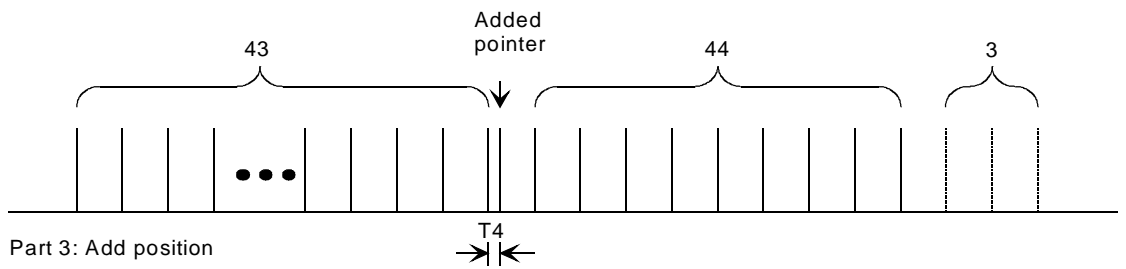
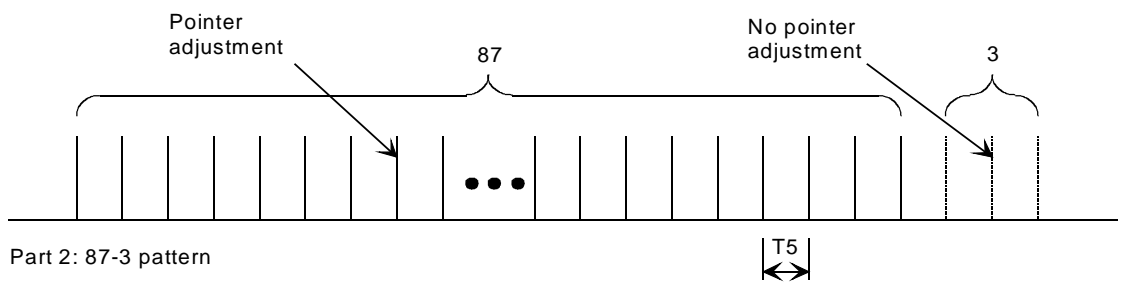
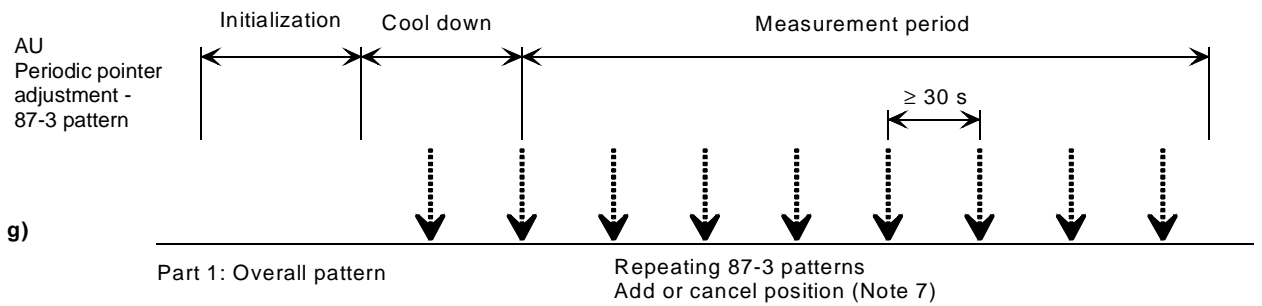
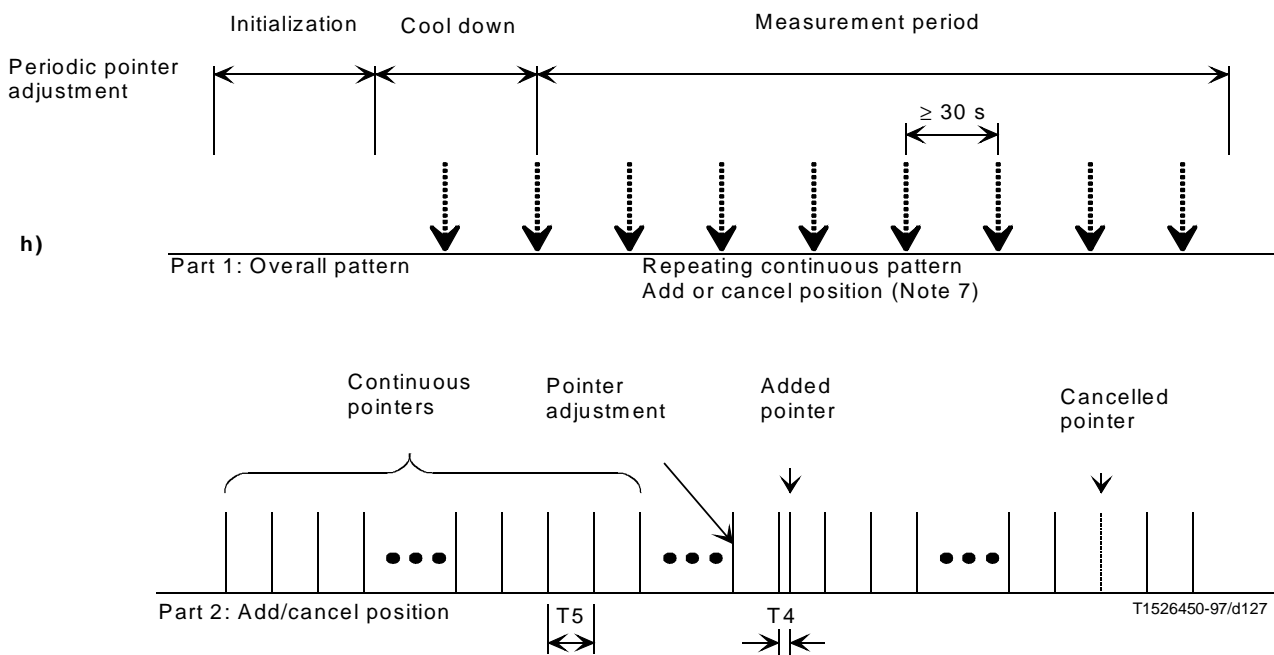

Figure 10-2/G.783 – Pointer test sequences (continued)



NOTE 1 – The payload output jitter is defined as the maximum jitter over the entire measurement period.

NOTE 2 – For AU-3 level payloads, the adjustments shall be applied to the STM-N level pointers. For VC level payloads, the adjustments shall be applied to the TU level pointers.

NOTE 3 – Complete payload data integrity shall be maintained through the SDH network.

NOTE 4 – For both single and burst sequences, separate tests shall be run first with all positive pointer adjustments and then with all negative pointer adjustments.

NOTE 5 – For periodic sequences, T5 is constant for each measurement and determined by the amount of frequency offset between the VC and its carrier (higher order path for lower order VCs and STM-N for higher order VCs). T5 shall be varied over the range given in Table 10-2, Notes 6 and 7.

NOTE 6 – All periodic tests must be done with positive frequency offsets and negative frequency offsets.

NOTE 7 – For periodic sequences, separate tests shall be run first with only added pointer adjustments and then with only cancelled pointer adjustments.

Figure 10-2/G.783 – Pointer test sequences (concluded)

11 Overhead Access Function (OHA)

In SDH equipment, it may be required to provide access in an integrated manner to transmission overhead functions. This subject is for further study in ITU-T. This Recommendation defines the U reference points across which information may be exchanged with the other functional blocks.

A particular overhead access function which may be included in SDH NEs is the order-wire function which is used to provide voice contact between SDH NEs for maintenance personnel.

The order-wire function of the OHA block shall be to accept E1 and E2 bytes from the U1 and U2 reference points and present them as data channels at one or more external interfaces as described in Table 11-1.

The use of multiplexed order-wire interfaces for NEs terminating a number of order-wire channels is for further study.

Table 11-1/G.783 – Orderwire interface

Bit rate (kbit/s)	Interface standard	Synchronization	Frame structure
64	Rec. G.703	Co-directional	Bit 1 of E1/E2 bytes in STM-N frame corresponds to bit 1 in the 64 kbit/s channel

Annex A

Multiplex Section Protection (MSP) protocol, commands and operation

A.1 MSP Protocol

The MSP functions, at the ends of a multiplex section, make requests for and give acknowledgments of switch action by using the MSP bytes (K1 and K2 bytes in the MSOH of the protection section). The bit assignments for these bytes and the bit-oriented protocol are defined as follows.

A.1.1 K1 byte

The K1 byte indicates a request of a channel for switch action.

Bits 1-4 indicate the type of request, as listed in Table A.1. A request can be:

- 1) a condition (SF and SD) associated with a section. A condition has high or low priority. The priority is set for each corresponding channel;
- 2) a state (wait to restore, do not revert, no request, reverse request) of the MSP function; or
- 3) an external request (lockout of protection, forced or manual switch, and exercise).

Bits 5-8 indicate the number of the channel for which the request is issued, as shown in Table A.2.

A.1.2 K1 byte generation rules

Local SF and SD conditions, wait to restore or do not revert state and the external request are evaluated by a priority logic, based on the descending order of request priorities in Table A.1. If local conditions (SF or SD) of the same level are detected on different sections at the same time, the condition with the lowest channel number takes priority. Of these evaluated requests, the one of the highest priority replaces the current local request, only if it is of higher priority.

Locally detected SF and SD conditions and externally initiated requests for working channels that have "lockout of working channel" control command (see A.2.2) applied to them are not evaluated during K1 byte generation.

A.1.2.1 In bidirectional operation

The priorities of the local request and the remote request on the received K1 byte are compared according to the descending order of priorities in Table A.1. Note that a received reverse request or a remote request for a working channel that has a "lockout of working channel" applied to it are not considered in the comparison.

Recommendation G.783 (04/97)

The sent K1 shall indicate:

- a) a reverse request if the remote bridge request is for a channel that is not locked out, and
 - i) the remote request is of higher priority; or if
 - ii) the requests are of the same level (and are higher priority than a no request) and the sent K1 byte already indicates reverse request; or if
 - iii) the requests are of the same level (and are higher priority than a no request) and the sent K1 byte does not indicate reverse request and the remote request indicates a lower channel number;
- b) the local request in all other cases.

Table A.1/G.783 – Types of request

Bits 1234	Condition, state or external request	Order (Note 1)
1111	Lockout of protection (Note 2)	Highest
1110	Forced switch	
1101	Signal fail high priority	
1100	Signal fail low priority	
1011	Signal degrade high priority	
1010	Signal degrade low priority	
1001	Unused (Note 3)	
1000	Manual switch	
0111	Unused (Note 3)	
0110	Wait to restore	
0101	Unused (Note 3)	
0100	Exercise	
0011	Unused (Note 3)	
0010	Reverse request	
0001	Do not revert	
0000	No request	Lowest

NOTE 1 – An SF condition on the protection section is higher priority than any of the requests that would cause a working channel to be selected from the protection section.

NOTE 2 – Only channel number 0 is allowed with a lockout of protection request.

NOTE 3 – Some network operators may use these codes for network specific purposes. The receiver shall be capable of ignoring these codes.

NOTE 4 – Requests are selected from the table depending on the protection switching arrangements; i.e. in any particular case, only a subset of the requests may be required.

Table A.2/G.783 – K1 channel number

Channel number	Requesting switch action
0	Null channel (no working channel or extra traffic channel). Conditions and associated priority (fixed high) apply to the protection section.
1-14	Working channel (1-14). Conditions and associated priority (high or low) apply to the corresponding working sections. For 1 + 1 only working channel 1 is applicable, with fixed high priority.
15	Extra traffic channel. Conditions are not applicable. Exists only when provisioned in a 1 : n architecture.

A.1.2.2 In unidirectional operation

The sent K1 byte shall always indicate the local request. Therefore, reverse request is never indicated.

A.1.3 Revertive/non-revertive modes

In revertive mode of operation, when the protection is no longer requested, i.e. the failed working section is no longer in SD or SF condition (and assuming no other requesting channels), a local wait to restore state shall be activated. Since this state becomes the highest in priority, it is indicated on the sent K1 byte, and maintains the switch on that channel. This state shall normally time out and become a no request null channel (or no request channel 15, if applicable). The wait to restore timer deactivates earlier if the sent K1 byte no longer indicates wait to restore, i.e. when any request of higher priority pre-empts this state.

In non-revertive mode of operation, applicable only to 1 + 1 architecture, when the failed working section is no longer in SD or SF condition, the selection of that channel from protection is maintained by activating a do not revert state or a wait to restore state rather than a no request state.

Both wait to restore and do not revert requests in the sent K1 byte are normally acknowledged by a reverse request in the received K1 byte. However, no request is acknowledged by another no request received.

A.1.4 K2 byte

Bits 1-5 indicate the status of the bridge in the MSP switch (see Figure A.1). Bits 6 to 8 are reserved for future use to implement drop and insert (nested) switching. Note that codes 111 and 110 will not be assigned for such use, since they are used for MS-AIS detection and MS-RDI indication. Also note that in some regional implementations, when MS-RDI is not being generated, bits 6 to 8 are used to indicate the switching mode (i.e. unidirectional, using code 100, and bidirectional, using code 101).

Bits 1-4 indicate a channel number, as shown in Table A.3. Bit 5 indicates the type of the MSP architecture: set 1 indicates 1 : n architecture and set 0 indicates 1 + 1 architecture.

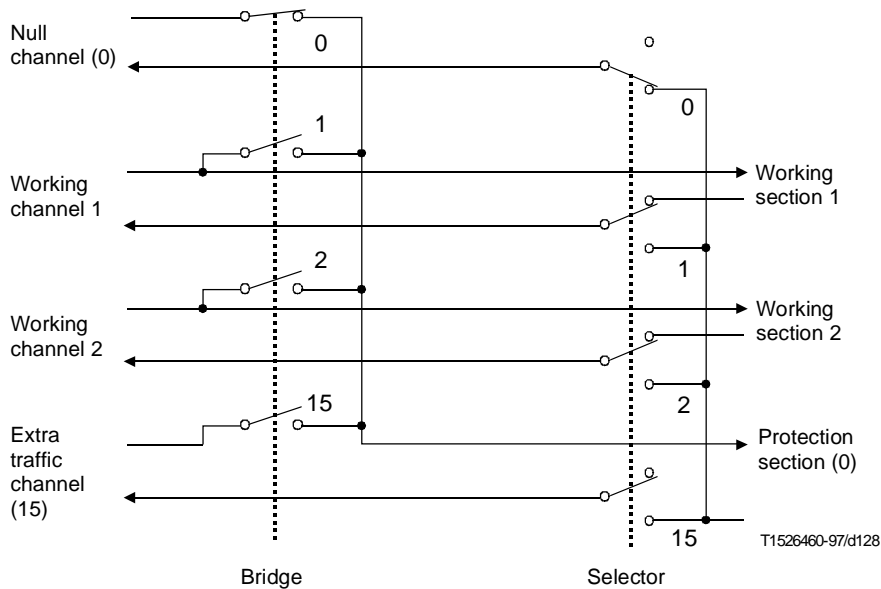

Figure A.1/G.783 – MSP switch – 1 : n architecture (shown in released position)

A.1.5 K2 byte generation rules

The sent K2 byte shall indicate in bits 1 to 4, for all architectures and operation modes:

- null channel (0) if the received K1 byte indicates null channel;
- the number of the channel which is bridged, in all other cases.

Table A.3/G.783 – K2 channel number

Channel number	Indication
0	Null channel.
1-14	Working channel (1-14). For 1 + 1, only working channel 1 is applicable.
15	Extra traffic channel. Exists only when provisioned in a 1 : n architecture.

The sent K2 byte shall indicate in bit 5:

- a) 0 if 1 + 1 architecture;
- b) 1 if 1 : n architecture.

Bit 5 of the sent and received K2 bytes may be compared; if a mismatch persists for 50 ms, a mismatch is indicated at reference point MSP_MP.

A.1.6 Control of the bridge

In 1 : n architecture, the channel number indicated on the received K1 byte controls the bridge. If, at the bridge end, the protection section is in SF condition, the bridge is:

- a) frozen (current bridge maintained), if the operation is unidirectional;
- b) released, if the operation is bidirectional.

In 1 + 1 architecture, the working channel 1 is permanently bridged to protection.

A.1.7 Control of the selector

In 1 + 1 architecture in unidirectional operation, the selector is controlled by the highest priority local request. If the protection section is in SF condition, the selector is released.

In 1 + 1 architecture in bidirectional operation, and in 1 : n architecture, the selector is controlled by comparing the channel numbers indicated on received K2 and sent K1 bytes. If there is a match, then the indicated channel is selected from the protection section. If there is a mismatch, the selector is released. Note that a match on 0000 also releases the selector. If the mismatch persists for 50 ms, a mismatch is indicated at reference point MSP_MP. If the protection section is in SF condition, the selector is released and the mismatch indication is disabled.

A.1.8 Transmission and acceptance of MSP bytes

Byte K1 and bits 1 to 5 of byte K2 shall be transmitted on the protection section. Although they may also be transmitted identically on working sections, receivers should not assume so, and should have the capability to ignore this information on the working sections.

MSP bytes shall be accepted as valid only when identical bytes are received in three consecutive frames.

Various conditions detected on the incoming K1 byte will cause an SF condition to be detected on the protection section. As noted in Table A.1, an SF condition on the protection section is higher priority than any of the requests that would cause a working channel to be selected from the protection section. Therefore, if the near end is signalling a request for a working channel, it will replace that request with an SF request with a channel number of "0000", which in turn will cause the selector to be released. Conditions that will cause an NE to consider the protection section to be in an SF condition include:

- In bidirectional operation, an inappropriate code that persists for 50 milliseconds in the received K1 bits 1-4. Appropriate codes are a higher priority request than the local request, an identical request to the local request, or a reverse request for any local request except no request. Any other value that persists for 50 milliseconds is considered an inappropriate code.
- In bidirectional operation, an inappropriate or invalid channel number that persists for 50 milliseconds in the received K1 bits 5-8.
- An LOS, LOF, excessive errors, or MS-AIS detected on the protection multiplex section.

In addition, it should be noted that the detection of an invalid channel number in K2 bits 1-4 will be detected as a mismatch of the sent K1 bits 5-8 and the received K2 bits 1-4, and will therefore cause the selector to be released.

A.2 MSP commands

The MSP function receives MSP control parameters and switch requests from the synchronous equipment management function at the MSP_MP reference point. A switch command issues an appropriate external request at the MSP function. Only one switch request can be issued at the MSP_MP. A control command sets or modifies MSP parameters or requests the MSP status.

Any external switch command not acknowledged by the far end within 2.5 seconds should be reported as failed, and the command and K byte request should be withdrawn.

A.2.1 Switch commands

A switch command issued at the MSP APS controller interface initiates one external bridge request for evaluation as described in A.1.1. Switch commands are listed below in the descending order of priority and the functionality of each is described.

- 1) *Clear* – Clears all switch commands listed below.
- 2) *Lockout of protection* – Denies all working channels (and the extra traffic channel, if applicable) access to the protection section by issuing a "lockout of protection" request unless equal protection switch command is in effect.
- 3) *Forced switch #* – Switches working channel # to the protection section, unless an equal or higher priority switch command is in effect or SF condition exists on the protection section, by issuing a forced switch request for that channel.

NOTE 1 – For 1 + 1 systems, forced switch no working channel transfers the working channel from protection to the working section, unless an equal or higher priority request is in effect. Since forced switch has higher priority than SF or SD on the working section, this command will be carried out regardless of the condition of the working section.

NOTE 2 – "Forced switch no working channel" has higher priority than "Forced switch-working channel 1" when both commands are detected at the same time.

- 4) *Manual switch #* – Switches working channel # to the protection section, unless a failure condition exists on other sections (including the protection section) or an equal or higher priority switch command is in effect, by issuing a manual switch request for that channel.

NOTE 3 – For 1 + 1 systems, manual switch no working channel transfers the working channel back from protection to the working section, unless an equal or higher priority request is in effect. Since manual switch has lower priority than SF or SD on a working section, this command will be carried out only if the working section is not in SF or SD condition.

NOTE 4 – "Manual switch no working channel" has higher priority than "Manual switch-working channel 1" when both commands are detected at the same time.

- 5) *Exercise #* – Issues an exercise request for that channel and checks responses on MSP bytes, unless the protection channel is in use. The switch is not actually completed, i.e. the selector is released by an exercise request on either the sent or the received and acknowledged K1 byte. The exercise functionality may not exist in all MSP functions.

Note that a functionality and a suitable command for freezing the current status of the MSP function is for further study.

A.2.2 Control commands

Control commands set and modify MSP protocol operation. The control commands that are currently defined apply only to 1 : n (unidirectional or bidirectional) switching.

Clear lockout working channel – Clears the lockout working channel command for the channel (or channels) specified.

Lockout working channel – Prevents the specified working channel (or channels) from switching to the protection channel.

These commands are not to be confused with the lockout of protection request, which prevents all working channels from using the protection section. The request to lock out an individual working channel or to clear the lockout of a

working channel shall be received at reference point MSP_MP. Lockout of working can be activated or cleared for each working channel independently, and any number of working channels can be locked out at the same time. The locked out status of a working channel is not directly reflected in the K bytes.

The operation of lockout of working channel depends on the mode of operation at the MS protection sublayer at which it is applied. If the operation is bidirectional, then the lockout also operates bidirectionally. If a channel has a lockout of working channel command applied, then local bridge requests are not issued for the locked-out channel (i.e. local conditions and external requests for the channel are not considered in the K1 byte generation process), and remote bridge requests for the channel are not acknowledged (i.e. remote requests for the channel are not considered in the K1 byte generation process and the requested bridge is not performed). Note that for bidirectional operation, the lockout of working channel command must be applied at both ends for proper operation.

If the operation is unidirectional, the lockout also operates unidirectionally. If a channel has a lockout of working channel command applied, then local bridge requests are not issued for the locked-out channel. However, remote bridge requests for that channel are acknowledged by performing the bridge and signalling that bridge in the K2 byte.

A.3 Switch operation

A.3.1 1 : n bidirectional switching

Table A.4 illustrates protection switching action between two multiplexer sites, denoted by A and C, of a 1 : n bidirectional protection switching system, shown in Figure 2-6/G.782.

When the protection section is not in use, null channel is indicated on both sent K1 and K2 bytes. Any working channel may be bridged to the protection section at the head end. The tail end must not assume or require any specific channel. In the example in Table A.4, working channel (Wch) 3 is bridged at site C, and Wch 4 is bridged at site A.

When a fail condition is detected or a switch command is received at the tail end of a multiplex section, the protection logic compares the priority of this new condition with the request priority of the channel (if any) on the protection. The comparison includes the priority of any bridge order; i.e. of a request on received K1 byte. If the new request is of higher priority, then the K1 byte is loaded with the request and the number of the channel requesting use of the protection section. In the example, SD is detected at C on working section 2, and this condition is sent on byte K1 as a bridge order at A.

At the head end, when this new K1 byte has been verified (after being received identically for three successive frames) and evaluated (by the priority logic), byte K1 is set with a reverse request as a confirmation of the channel to use the protection and order a bridge at the tail end for that channel. This initiates a bidirectional switch. Note that a reverse request is returned for exerciser and all other requests of higher priority. This clearly identifies which end originated the switch request. If the head end had also originated an identical request (not yet confirmed by a reverse request) for the same channel, then both ends would continue transmitting the identical K1 byte and perform the requested switch action.

Also, at the head end, the indicated channel is bridged to protection. When the channel is bridged, byte K2 is set to indicate the number of the channel on protection.

At the tail end, when the channel number on received byte K2 matches the number of the channel requesting the switch, that channel is selected from protection. This completes the switch to protection for one direction. The tail end also performs the bridge as ordered by byte K1 and indicates the bridged channel on byte K2.

Table A.4/G.783 – 1 : n bidirectional protection switching example

Failure condition or controller state	APS bytes				Action	
	C → A		A → C			
	Byte K1	Byte K2	Byte K1	Byte K2	At C	At A
No failures (protection section not in use).	00000000	00001000	00000000	00001000	Wch 3 is bridged onto protection to provide a valid signal. Selector is released.	Wch 4 is bridged onto protection to provide a valid signal. Selector is released.
Working section 2 degraded in direction A → C.	10100010	00001000	00000000	00001000	Failure detected. Order Wch 2 bridge – SD.	
	10100010	00001000	00100010	00101000		Bridge Wch 2. Reverse order Wch 2 bridge.
	10100010	00101000	00100010	00101000	Switch Wch 2. Bridge Wch 2.	
	10100010	00101000	00100010	00101000		Switch Wch 2. Bidirectional switch completed.
Working section 1 failed in direction C → A. (This pre-empts the Wch 2 switch.)	10100010	00101000	11000001	00101000		Failure detected. Order Wch 1 bridge – SF. Release Wch 2 switch.
	00100001	00011000	11000001	00101000	Bridge Wch 1. Reverse order Wch 1 bridge. Release Wch 2 switch.	
	00100001	00011000	11000001	00011000		Switch Wch 1. Bridge Wch 1.
	00100001	00011000	11000001	00011000	Switch Wch 1. Bidirectional switch completed.	
Working section 1.	00100001	00011000	01100001	00011000		Wait to restore
Repaired (Working section 2 still degraded).	10100010	00011000	01100001	00011000	Order Wch 2 bridge. Release Wch 1 switch.	
	10100010	00011000	00100010	00101000		Bridge Wch 2. Reverse order Wch 2 bridge. Release Wch 1 switch.
	10100010	00101000	00100010	00101000	Bridge Wch 2. Switch Wch 2.	
	10100010	00101000	00100010	00101000		Switch Wch 2. Bidirectional switch completed.
Working section 2 repaired.	01100010	00101000	00100010	00101000	Wait to restore Wch 2.	

Table A.4/G.783 – 1 : n bidirectional protection switching example (concluded)

Failure condition or controller state	APS bytes				Action	
	C → A		A → C			
	Byte K1	Byte K2	Byte K1	Byte K2	At C	At A
Wait to restore expired (no failures).	00000000	00101000	00100010	00101000	Drop Wch 2 bridge order. Release Wch 2 switch.	
	00000000	00101000	00000000	00001000		Drop Wch 2 bridge Drop. Drop Wch 2 bridge order. Release Wch 2 switch.
	00000000	00001000	00000000	00001000	Drop Wch 2 bridge (Wch 3 is bridged).	(Wch 4 is bridged).

The head end completes the bidirectional switch by selecting the channel from protection when it receives a matching K2 byte.

If the switch is not completed because the requested/bridged channels did not match within 50 ms, the selectors would remain released and the failure of the protocol would be indicated. This may occur when one end is provisioned as unidirectional and the other as bidirectional. A mismatch may also occur when a locked-out channel at one end is not locked out at the other. Note that a mismatch may also occur when a 1 + 1 architecture connects to a 1 : 1 architecture (which is not in a provisioned for 1 + 1 state), due to a mismatch of bit 5 on K2 bytes. This may be used to provision the 1 : 1 architecture to operate as 1 + 1.

The example further illustrates a priority switch, when an SF condition on working section 1 pre-empts the Wch 2 switch. Note that selectors are temporarily released before selecting Wch 1, due to temporary channel number mismatch on sent K1 and received K2 bytes. Further in the example, switching back Wch 2 after failed section 1 is repaired is illustrated.

When the switch is no longer required, e.g. the failed working section has recovered from failure and wait to restore has expired, the tail end indicates no request for null channel on byte K1 (00000000). This releases the selector due to channel number mismatch.

The head end then releases the bridge and replies with the same indication on byte K1 and null channel indication on byte K2. The selector at the head end is also released due to mismatch.

Receiving null channel on K1 byte causes the tail end to release the bridge. Since the K2 bytes now indicate null channel which matches the null channel on the K1 bytes, the selectors remain released without any mismatch indicated, and restoration is completed.

A.3.2 1 : n unidirectional switching

All actions are as described in A.3.1 except that the unidirectional switch is completed when the tail end selects from protection the channel for which it issued a request. This difference in operation is obtained by not considering remote requests in the priority logic and therefore not issuing reverse requests.

A.3.3 1 + 1 unidirectional switching

For 1 + 1 unidirectional switching, the channel selection is based on the local conditions and requests. Therefore each end operates independently of the other end, and bytes K1 and K2 are not needed to coordinate switch action. However, byte K1 is still used to inform the other end of the local action, and bit 5 of byte K2 is set to zero.

A.3.4 1 + 1 bidirectional switching

The operation of 1 + 1 bidirectional switching can be optimized for a network in which 1 : n protection switching is widely used and which is therefore based on compatibility with a 1 : n arrangement; alternatively it can be optimized for a network in which predominantly 1 + 1 bidirectional switching is used. This leads to two possible switching operations described below and in Annex B.

A.3.4.1 1 + 1 bidirectional switching compatible with 1 : n bidirectional switching

Bytes K1 and K2 are exchanged as described in A.3.1 to complete a switch. Since the bridge is permanent, i.e. working channel number 1 is always bridged, Wch 1 is indicated on byte K2, unless received K1 indicates null channel (0). Switching is completed when both ends select the channel, and may take less time because K2 indication does not depend on a bridging action.

For revertive switching, the restoration takes place as described in A.3.1. For non-revertive switching, Table A.5 illustrates the operation of a 1 + 1 bidirectional protection switching system, shown in Figure 2-5/G.782.

For non-revertive operation, assuming the working channel is on protection, when the working section is repaired, or a switch command is released, the tail end maintains the selection and indicates do not revert for Wch 1. The head end also maintains the selection and continues indicating reverse request. The do not revert is removed when pre-empted by a failure condition or an external request.

Table A.5/G.783 – Example of 1 + 1 bidirectional switching compatible with 1 : n bidirectional switching

Failure condition or controller state	APS bytes				Action	
	C → A		A → C			
	Byte K1	Byte K2	Byte K1	Byte K2	At C	At A
No failures (assume protection section not in use).	00000000	00000000	00000000	00000000	Selector is released.	Selector is released.
Working section 1 failed in direction A → C.	11010001	00000000	00000000	00000000	Failure detected. Order Wch 1 bridge – SF.	
	11010001	00000000	00100001	00010000		Indicate Wch 1 bridged. Reverse order Wch 1 bridge.
	11010001	00010000	00100001	00010000	Indicate Wch 1 bridged. Switch Wch 1.	
	11010001	00010000	00100001	00010000		Switch Wch 1. Bidirectional switch completed.
Working section 1 repaired. Maintain switch (non-revertive).	00010001	00010000	00100001	00010000	Send do not revert.	
Protection section degraded in direction A → C.	10110000	00010000	00100001	00010000	Failure detected. Order null ch bridge – SD. Release Wch 1 switch.	

Table A.5/G.783 – Example of 1 + 1 bidirectional switching compatible with 1 : n bidirectional switching (concluded)

Failure condition or controller state	APS bytes				Action	
	C → A		A → C			
	Byte K1	Byte K2	Byte K1	Byte K2	At C	At A
Protection section degraded in direction A → C. (cont.)	10110000	00010000	00100000	00000000		Reverse order null ch bridge. Drop Wch 1 bridge. Release Wch 1 switch.
	10110000	00000000	00100000	00000000	Drop Wch 1 bridge.	
Protection section repaired.	00000000	00000000	00100000	00000000	Send no request.	

Annex B

Multiplex section protection (MSP) 1 + 1 optimized protocol, commands and operation

B.1 1 + 1 bidirectional switching optimized for a network using predominantly 1 + 1 bidirectional switching

This algorithm uses working sections 1 and 2 in order to realize high speed 1 + 1 non-revertive protection switching. In other words, revertive action is prevented by switching between working sections.

Bytes K1 and K2 (b1-b5) are exchanged to complete a switch. Since the bridge is permanent (see Figure B.1), the traffic is always bridged to the working section 1 and working section 2. Byte K2 indicates the number of the section which carries traffic when no switch is active. This will be referred to as the primary section. The other working section, referred to as the secondary section, provides protection for the primary section. Exchange of K1/K2 to control this protection occurs over the secondary section. The section number on byte K2 will be changed after a switch has cleared. Clearing of a switch is completed when both the receive end switches select the other working section as primary and receive no request.

In 1 + 1 bidirectional optimized switching, both section 1 and 2 are equal to working sections. K1/K2 bytes are received on the secondary section. K1/K2 bytes need not always be received on the primary section, but in general, K1/K2 must be sent on both sections to provide for successful clearing operations and to allow recovery of the primary channel mismatch condition (see B.1.5).

In 1 + 1 bidirectional operation optimized for a network using predominately 1 + 1 bidirectional switching, the selector is on the primary section in the absence of a switch request. All switch requests are for a switch from the primary section to the secondary section. Once a switch request clears normally, traffic is maintained on the section to which it was switched by making that section the primary section.

B.1.1 Lockout

In 1 + 1 bidirectional optimized switching, lockout is considered as a local request which is not signalled across the K bytes. The effect of lockout is to freeze the selector position and transmitted K bytes until the lockout request is cleared. When a lockout request is cleared, the selector and transmitted K bytes will be set by applying any changed section conditions and incoming K bytes to the previous state.

Bits 5-8 indicate the number of the section to be protected by the switch. This will be the null section for no request, and the primary section for all other requests.

Table B.2/G.783 – K1 channel number

Channel number	Requesting switch action
0	No working section (no request only).
1	Working section 1. Indicates a request to switch away from section number 1.
2	Working section 2. Indicates a request to switch away from section number 2.

B.1.4 K2 byte coding

For 1 + 1 bidirectional switching optimized for a network using predominantly 1 + 1 bidirectional switching, the sent K2 byte shall indicate the selector position in bits 1-4:

- a) Channel number 1 (0001) if section 1 is working.
- b) Channel number 2 (0010) if section 2 is working.

Table B.3/G.783 – K2 channel number

Channel number	Indication
1	Section 1 is primary.
2	Section 2 is primary.

B.1.5 Primary section mismatch

In the event that the near end and far end disagree about which section is primary (i.e. one end is indicating section 1 in byte K2 and the other is indicating section 2), the side that believed section 2 was primary shall change so that section 1 is primary and set its state according to local line conditions and the incoming K bytes.

B.2 Switch commands

Forced switch

Transfers service to the secondary section, unless a local lockout is in effect, an equal or higher priority request is in effect, or the secondary section has failed. Since forced switch has higher priority than SF or SD, forced switch will be indicated as the reason for the switch to the secondary section even if the primary section is in an SF or SD condition.

Forced switch clear

If no lockout is in effect and a forced switch is active, the switch will be cleared by changing the primary line indication to the currently active line and changing the request to no request. If no forced switch is active, the forced switch clear command is invalid.

B.3 Switch operation

Table B.4 illustrates the operation of a 1 + 1 bidirectional protection switching system for signal failure on the primary section when section 1 is primary. Table B.5 illustrates the operation of a 1 + 1 bidirectional optimized protection switching system for a forced switch from the primary to the secondary section when section 2 is primary. Note that for a forced switch command, the wait to restore state is not necessary for clearing.

Table B.4/G.783 – Example of 1 + 1 bidirectional switching optimized for a network using predominantly 1 + 1 bidirectional switching – SF on working section 1

Failure condition or controller state	APS bytes				Action	
	C → A		A → C			
	Byte K1	Byte K2	Byte K1	Byte K2	At C	At A
No fault condition traffic on channel 1.	00000000	00010000	00000000	00010000		
Signal fail on section 1 at side C.	11000001	00010000	00000000	00010000	Detect local request. Update K1.	
	11000001	00010000	00100001	00010000		Detect remote request. Switch to channel 2. Issue reverse request.
	11000001	00010000	00100001	00010000	Detect reverse request. Switch to channel 2.	
Signal fail on section 1 at side C cleared and persistence check.	01100001	00010000	00100001	00010000	Issue wait to restore request.	
Wait to restore expires.	00000000	00100000	00100001	00010000	Send no request. Update K1, K2.	
No fault condition. Traffic on section 2.	00000000	00100000	00000000	00100000		Send no request. Update K1, K2.

Table B.5/G.783 – Example of 1 + 1 bidirectional switching optimized for a network using predominantly 1 + 1 bidirectional switching – Forced switch from working section 2

Failure condition or controller state	APS bytes				Action	
	C → A		A → C			
	Byte K1	Byte K2	Byte K1	Byte K2	At C	At A
No fault condition traffic on channel 2.	00000000	00100000	00000000	00100000		
Forced switch from Section 2 at side C.	11100010	00100000	00000000	00100000	Detect local request. Update K1.	
	11100010	00100000	00100010	00100000		Detect remote request. Switch to channel 2. Issue reverse request.
	11100010	00100000	00100010	00100000	Detect reverse request. Switch to channel 2.	
Clear forced switch at side C	00000000	00010000	00100010	00100000	Send no request. Update K1, K2.	
No switch active. Traffic on section 1.	00000000	00010000	00000000	00010000		Send no request. Update K1, K2.

Annex C

Algorithm for pointer detection

C.1 Pointer interpretation

The pointer processing algorithm can be modelled by a finite state machine. Within the pointer interpretation algorithm three states are defined (as shown in Figure C.1):

- NORM_state;
- AIS_state;
- LOP_state.

The transitions between the states will be consecutive events (indications), e.g. three consecutive AIS indications to go from NORM_state to the AIS_state. The kind and number of consecutive indications activating a transition is chosen such that the behaviour is stable and insensitive to bit errors.

The only transition on a single event is the one from the AIS_state to the NORMAL_state after receiving an NDF enabled with a valid pointer value.

It should be noted that, since the algorithm only contains transitions based on consecutive indications, this implies that non-consecutively received invalid indications do not activate the transitions to the LOP_state.

The following events (indications) are defined:

- Norm_point: Normal NDF AND match of ss bits AND offset value in range.
- NDF_enable: NDF enabled AND match of ss bits AND offset value in range.
- AIS_ind: 11111111 11111111.
- Incr_ind: Normal NDF AND match of ss bits AND majority of I bits inverted AND no majority of D bits inverted AND previous NDF_enable, incr_ind or decr_ind more than 3 times ago.
- Decr_ind: Normal NDF AND match of ss bits AND majority of D bits inverted AND no majority of I bits inverted AND previous NDF_enable, incr_ind or decr_ind more than 3 times ago.
- Inv_point: Any other OR norm_point with offset value not equal to active offset.

NOTE 1 – Active offset is defined as the accepted current phase of the VC in the NORM_state and is undefined in the other states.

NOTE 2 – NDF enabled is equal to 1001, 0001, 1101, 1011, 1000.

NOTE 3 – Normal NDF is equal to 0110, 1110, 0010, 0100, 0111.

The transitions indicated in the state diagram are defined as follows:

- Inc_ind/dec_ind: Offset adjustment (increment or decrement indication).
- $3 \times$ norm_point: Three consecutive equal norm_point indications.
- NDF_enable: Single NDF_enable indication.
- $3 \times$ AIS_ind: Three consecutive AIS indications.
- $N \times$ inv_point: N consecutive inv_point ($8 \leq N \leq 10$).
- $N \times$ NDF_enable: N consecutive NDF_enable ($8 \leq N \leq 10$).

NOTE 4 – The transitions from NORM to NORM do not represent changes of state but imply offset changes.

NOTE 5 – $3 \times$ norm_point takes precedence over $N \times$ inv_point.

NOTE 6 – In some applications interworking with North American countries may require that the ss bits in the AU-*n* pointer be ignored.

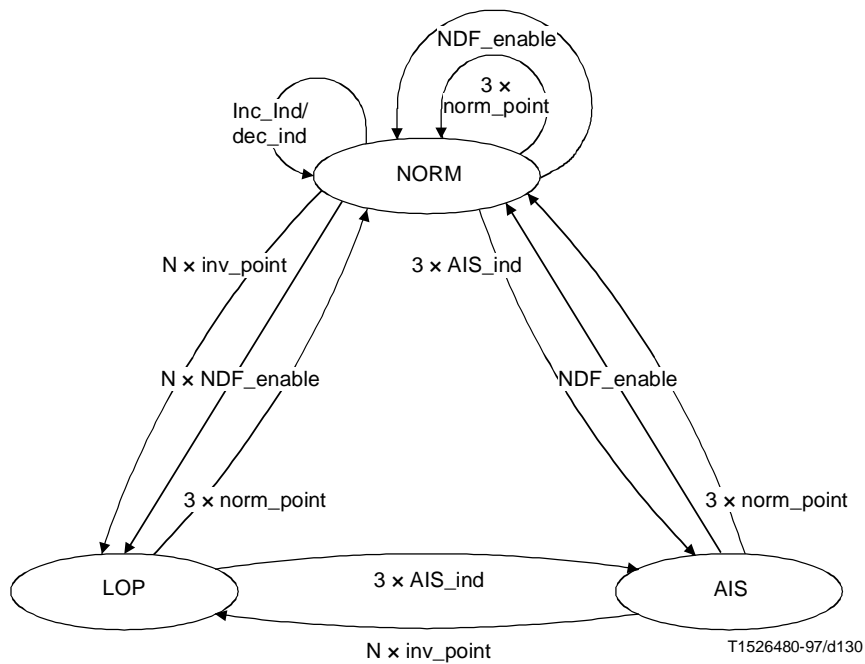

Figure C.1/G.783 – Pointer interpretation state diagram

C.2 Concatenated payloads

In case of contiguous concatenations, the algorithm to verify the presence of a concatenation indicator instead of a normal pointer can be described conveniently in the same way as for a normal pointer. This is shown by the state diagram of Figure C.2. Again, three states have been described:

- CONC_state;
- LOPC_state;
- AISC_state.

The following events (indications) are defined:

- Conc_ind: NDF enabled + dd 1111111111.
- AIS_ind: 11111111 11111111.
- Inv_point: Any other.

NOTE – dd bits are unspecified in Recommendation G.707 and therefore do not concern the algorithm.

The transitions indicated in the state diagram are defined as follows:

- 3 x AIS_ind: Three consecutive AIS indications.
- N x inv_point: N consecutive inv_point ($8 \leq N \leq 10$).
- 3 x conc_ind: Three consecutive conc_ind.

A defect in one or more of the AUs and TUs of a concatenated payload results in the detection of a defect in the concatenated payload. Two types of defects can be reported:

- Loss of pointer;
- Path AIS.

A loss of pointer defect is defined as a transition of the pointer interpreter from the NORM_state to the LOP_state or the AIS_state, or a transition from the CONC_state to the LOPC_state or AISC_state in any concatenated AU/TU. In case both the pointer interpreter is in the AIS_state and the concatenation indicators of all concatenated AU/TUs are in the AISC_state, an AU/TU-AIS defect will be reported.

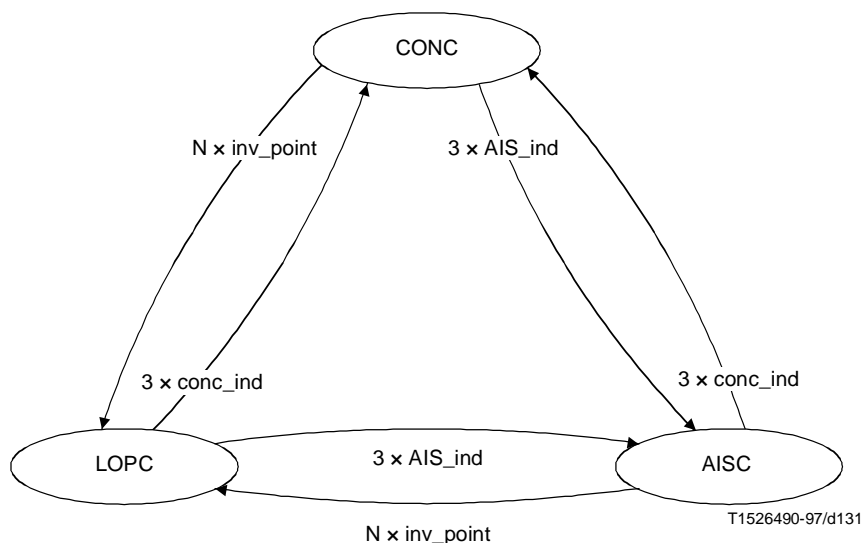
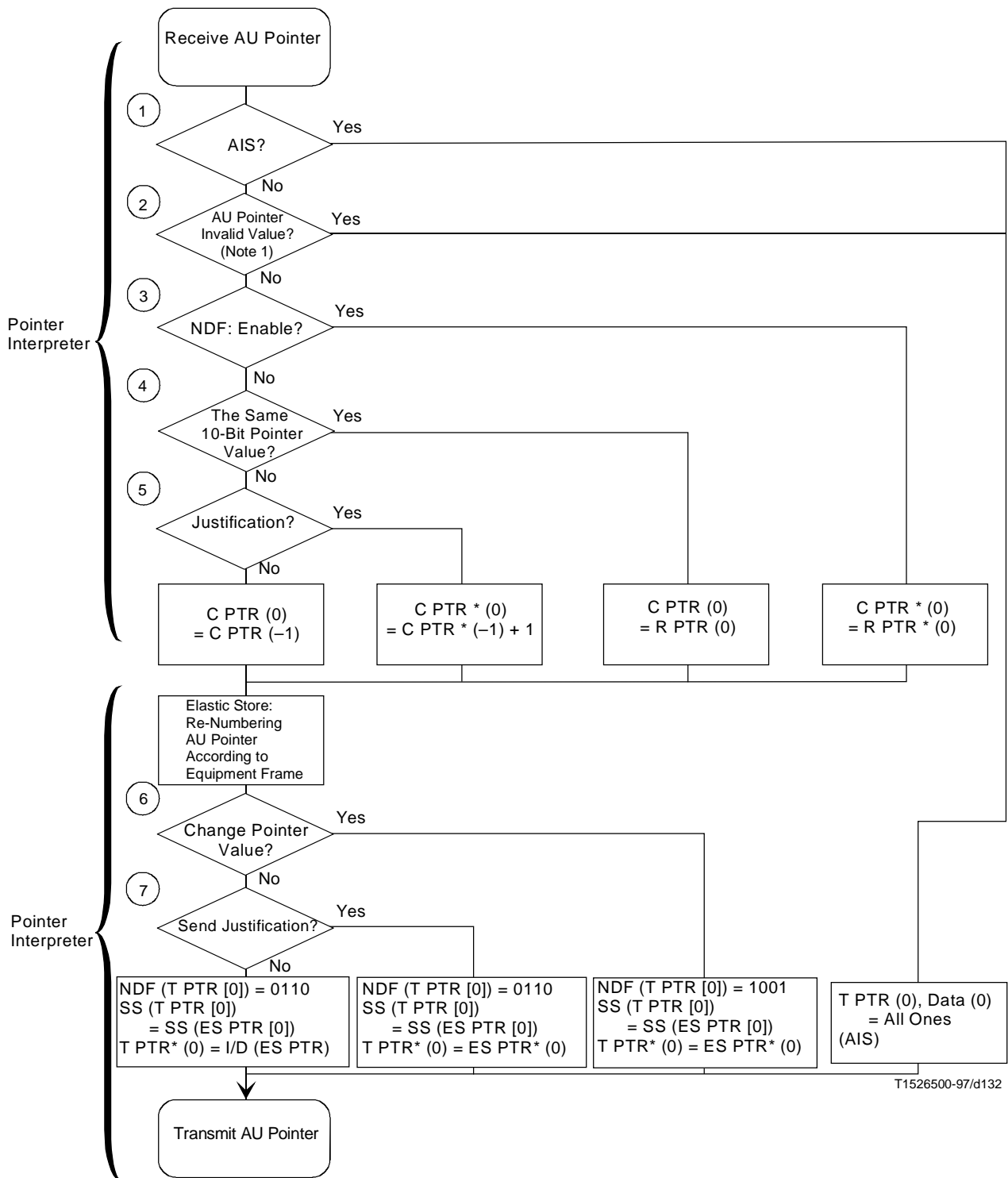

Figure C.2/G.783 – Concatenation indicator state diagram

C.3 Pointer processing flow chart

The mechanism of pointer processing is illustrated as a flow chart in Figure C.3.



T1526500-97/d132

C PTR []	AU Pointer Value Inside Equipment	Data	Payload Data
R PTR []	AU Pointer Value Received	NDF (T PTR [])	NDF in AU Pointer
T PTR []	AU Pointer Value Transmitted	SS (T PTR [])	SS Bits in AU Pointer Value Transmitted
ES PTR []	Output AU Pointer Value of an elastic store	SS (ES PTR [])	SS Bits in AU Pointer Value of an elastic store
I/D ()	Invert I or D Bit of AU Pointer	*	10-Bit Pointer
		n	The n-th Frame Preceding the Present One

NOTE 1 – Concatenation Indication (CI) should be interpreted at this point. From the rules in Recommendation G.707, the first AU-4 of an AU-4-Xc shall be interpreted according to the flow chart; the pointers of the other AU-4s contain CI bits, and the pointer processor shall perform the same operation as performed on the first AU-4.

NOTE 2 – AU Pointer: NDF, SS, 10-bit pointer.

Figure C.3/G.783 – Pointer processing flow chart

Annex D

PDH physical section layers

The contents of this Annex are functional PDH specification that would not normally be part of an SDH functional specification. However, since the material does not exist elsewhere, it will be kept here in an annex until such PDH specifications exist.

D.1 PDH physical section layer (*Eq*)

The PDH physical section layers are the 139 264, 44 736, 34 368, 6312, 2048 and 1554 kbit/s section layers.

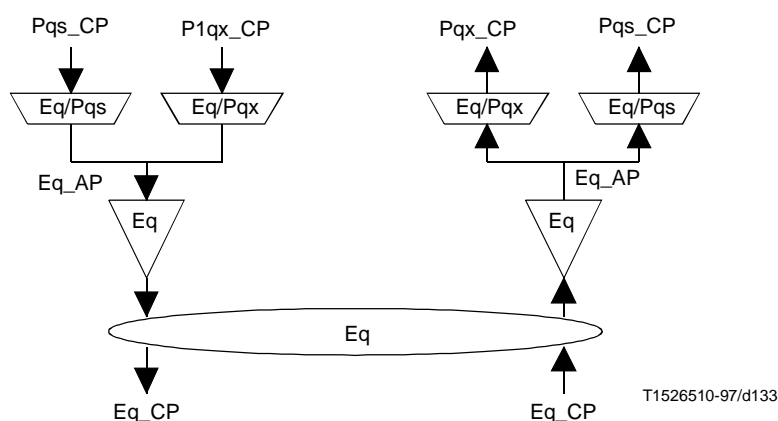

Figure D.1/G.783 – Low order SDH path layer atomic functions

PDH physical section *Eq* layer characteristic information

The characteristic information *Pq_CI* has co-directional timing and is a digital, electrical signal of defined amplitude, bit rate, impedance and pulse shape specified by Recommendation G.703.

PDH physical section *Eq* layer adaptation information

The information passing across the *Eq/Pqx* AP is a 139 264, 44 736, 34 368, 6312, 2048 or 1554 kbit/s signal with co-directional bit timing.

The information passing across the *Eq/Pqs* AP is a 2048 or 1544 kbit/s signal with co-directional bit timing with a frame structure specified by Recommendation G.704.

Layer functions

Eq_C PDH physical section connection function.

Eq_TT PDH physical section termination function.

Eq/Pq_A PDH physical section adaptation functions.

Relationship to previous versions of Recommendation G.783

The 1994 version of Recommendation G.783 refers to the PPI basic functions. Table D.1 shows the relationship between the basic functions and the atomic functions in the lower order path layers.

Table D.1/G.783 – PDH physical section layer basic and atomic functions

Basic function	Atomic function
PPI	Pq_TT_So Pq_TT_Sk Eq/Pqs_A_So Eq/Pqs_A_Sk

D.1.1 Connection (N/A)

For further study.

D.1.2 Termination

The PDH physical section termination function provides the interface between the equipment and the physical medium carrying a signal which may have any of the physical characteristics of those described in Recommendation G.703.

The PDH physical section termination function comprises the atomic functions PDH physical section trail termination source [Eq_TT_So, q = (11, 12, 21, 31, 32 or 4)] and sink [Eq_TT_Sk, q = (11, 12, 21, 31, 32 or 4)] as illustrated in Figure D.2 and Tables D.2 and D.3.

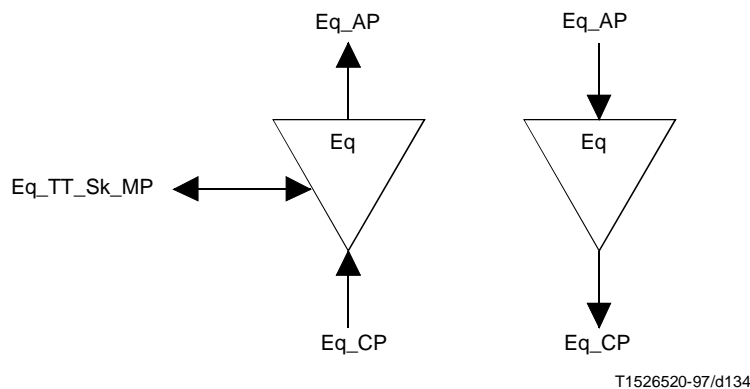

Figure D.2/G.783 – PDH physical section termination function

D.1.2.1 Source direction

Interfaces

Table D.2/G.783 – PDH physical section termination source input and output signals

Input(s)	Output(s)
Eq_AI_Data	Eq_CI_Data

Processes

The functions performed by the Eq_TT_So are encoding and adaptation to the physical medium as defined in Recommendation G.703. Eq_TT_So takes data at the Eq_AP to form the electrical signal at Eq_CP. The Eq_TT_So passes the data and timing information transparently.

Defects

None.

Consequent actions

None.

Defect correlation

None.

Performance monitoring

None.

D.1.2.2 Sink direction**Interfaces****Table D.3/G.783 – PDH physical section termination sink input and output signals**

Input(s)	Output(s)
Eq_CI_Data	Eq_AI_Data Eq_AI_TSF
Eq_TT_Sk_MI_TPmode	Eq_TT_Sk_MI_cLOS

Processes

The Eq_TT_Sk function recovers the electrical signals specified in Recommendation G.703.

The operation of Port mode is described in section 2.2.1.

Defects

The function shall detect for dLOS defects according to the specification in 2.2.

Consequent actions

The function shall perform the following consequent actions:

aTSF ← dLOS

Defect correlation

The function shall perform the following defect correlation to determine the most probable fault cause. This fault cause shall be reported to the SEMF.

cLOS ← dLOS and MON

Performance monitoring

None.

D.1.3 Adaptation functions Eq/Pqx_A and Eq/Pqs_A

The PDH physical section adaptation function comprises the atomic functions PDH physical section adaptation source [Eq/Pqx_A_So, q = (11, 12, 21, 31, 32 or 4) or Eq/Pqs_A_So, q = (11 or 12)] and sink [Eq/Pqx_A_Sk or Eq/Pqs_A_Sk, q = (11 or 12)] as illustrated in Figure D.3 and Tables D.4, D.5 and D.6.

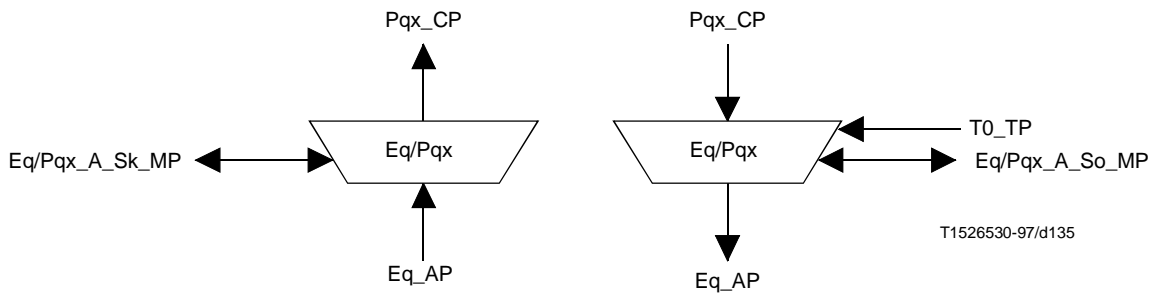

NOTE – In case of byte synchronous mappings, *Pqx* should be read as *Pqs*.

Figure D.3/G.783 – PDH physical section adaptation function

D.1.3.1 Source direction

Interfaces

Table D.4/G.783 – PDH physical section adaptation source input and output signals

Input(s)	Output(s)
<i>Pqx_CI_Data</i> <i>Pqx_CI_Clock</i> <i>Eq/Pqx_A_So_MI_Active</i>	<i>Eq_AI_Data</i>
NOTE – In case of byte synchronous mappings, <i>Pqx</i> should be read as <i>Pqs</i> .	

Processes

The *Eq/Pqx_A_So* function takes data and timing at the *Pqx_CP* or *Pqs_CP* and adds line code to form the transmit signal at the *Eq_AP*.

Defects

None.

Consequent actions

None.

Defect correlation

None.

Performance monitoring

None.

D.1.3.2 Sink direction *Eq/Pqx_A_Sk*

Interfaces

Table D.5/G.783 – PDH physical section adaptation sink input and output signals

Input(s)	Output(s)
<i>Eq_AI_Data</i> <i>Sm_AI_TSF</i> <i>Sm/Pqx_A_Sk_MI_Active</i>	<i>Pqx_CI_Data</i> <i>Pqx_CI_Clock</i> <i>Pqx_CI_SSF</i>

Processes

The *Eq/Pqx_A_Sk* function extracts timing from the received signal at the *Eq_AP* and regenerates the data. After decoding, it passes the data and timing information to the *Pqx_CP*. The timing may also be provided at reference point *TP_T2* for possible use as a reference in the SETS.

Defects

None.

Consequent actions

The function shall perform the following consequent actions:

aAIS ← AI_SSF

aSSF ← AI_TSF

In the event of aAIS, an all-ONEs (AIS) data signal shall be applied at the *Pqx_CP* accompanied by a suitable reference timing signal within 250 µs. Upon termination of aAIS, the all-ONEs signal shall be terminated within 250 µs.

NOTE – In the case of 45 Mbit/s interface, the AIS is defined in Recommendation M.20.

Defect correlation

None.

Performance monitoring

None.

D.1.3.3 Sink direction *Eq/Pqs_A_Sk*

Interfaces

Table D.6/G.783 – PDH physical section adaptation sink input and output signals

Input(s)	Output(s)
<i>Eq_AI_Data</i> <i>Eq_AI_TSF</i>	<i>Pqs_CI_Data</i> <i>Pqs_CI_Clock</i> <i>Pqs_CI_FrameStart</i> <i>Pqs_CI_MultiFrameStart</i> <i>Pqs_CI_SSF</i>
<i>Eq/Pqs_A_Sk_MI_AIS_Reported</i> <i>Eq/Pqs_A_Sk_MI_Active</i> <i>Eq/Pqs_A_Sk_MI_CRC4mode</i>	<i>Eq/Pqs_A_Sk_MI_cLOF</i> <i>Eq/Pqs_A_Sk_MI_cAIS</i> <i>Eq/Pqs_A_Sk_MI_NCI</i>

Processes

The *Eq/Pqs_A_Sk* function extracts timing from the received signal at the *Eq_AP* and regenerates the data. After decoding, it recovers the *FrameStart* and *MultiFrameStart* and passes the data, timing and frame start information to the *Pqs_CP*. The timing may also be provided at reference point *TP_T2* for possible use as a reference in the SETS.

Defects

The function shall detect for dLOF and dAIS defects according to the specification in 2.2.

Consequent actions

The function shall perform the following consequent actions:

aAIS ← AI_TSF or dAIS or dLOF

aSSF ← AI_TSF or dAIS or dLOF

In the event of aAIS, an all-ONES (AIS) data signal shall be applied at the Pqs_CP accompanied by a suitable reference timing signal within 250 μs. Upon termination of aAIS, the all-ONES signal shall be terminated within 250 μs.

Defect correlation

cAIS ← dAIS and (not AI_TSF) and AIS_Reported

cLOF ← dLOF and (not dAIS) and (not AI_TSF)

Performance monitoring

None.

Appendix I

Example of F1 byte usage

Recommendation G.784 describes usage of DCCs for maintenance of the SDH network including regenerators. To introduce cost-effective regenerators, this Appendix shows an example of F1 byte usage to identify a failed section in a chain of regenerator sections. When a regenerator detects a failure in its section, it inserts its regenerator number and the status of its failure into the F1 byte. Figure I.1 illustrates the procedure.

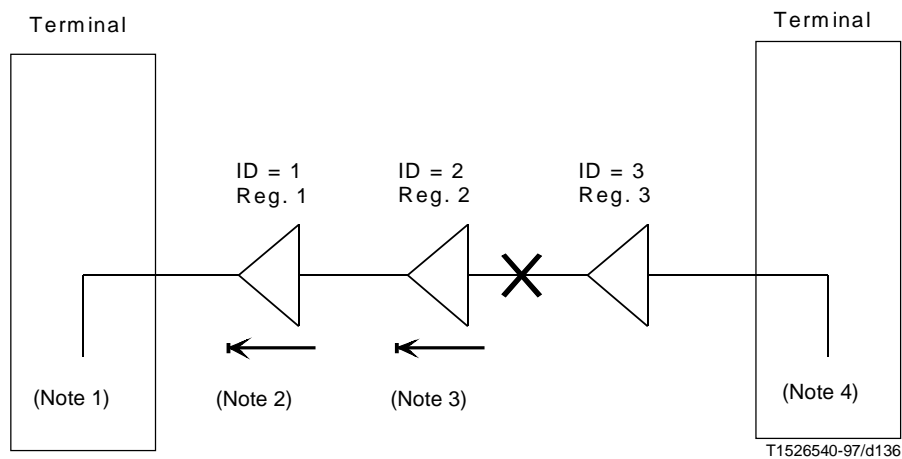

NOTE 1 – The terminal receives the regenerator’s alarms and reports them.

NOTE 2 – If the regenerator status is normal, it should transfer received F1 byte to the downstream without any change.

NOTE 3 – If Reg. 2 detects LOS, LOF, SD(B1) or ERR MON on the upstream side, then it sends the regenerator number and status information to the downstream side using the F1 byte. These alarms are defined as follows:

- LOF or LOS Loss of frame or loss of signal.
- SD(B1) Signal degrade calculated by B1 byte.
- ERR MON Error detection by monitoring B1 byte.

If the procedures SD(B1) and ERR MON are used, it is necessary that the RST function regarding B1 calculation be enhanced.

NOTE 4 – Normal is inserted into F1 byte by the terminal.

Figure I.1/G.783 – Chain of regenerator sections

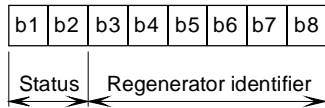

- 00 Normal
- 01 SD(B1)
- 10 LOS or LOF
- 11 ERR MON

T1526550-97/d137

Figure I.2/G.783 – Definition of F1 byte

Appendix II

CM configuration examples

The connection function as defined in 6.1.1 is highly flexible. To illustrate this, examples of a number of basic classes of the connection function are given below.

- i) *Connection matrix example for 1-port* – The set of input and output ports is not divided into subsets, as shown in Figure II.1. This CM allows interconnectivity as given in Table II.1.

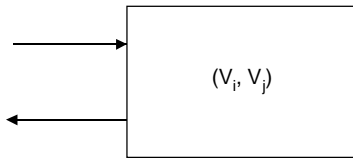

T1526560-97/d138

Figure II.1/G.783 – Connection matrix example for 1-port S_n_C

Table II.1/G.783 – Connection matrix example for 1-port

	V_j
V_i	X
X Indicates V_i - V_j connection possible for any i and j.	

- ii) *Connection matrix example for 2-port type I* – The set of input and output ports is divided into two subsets, each containing both input and output ports – Line (L) and Trib (T) as shown in Figure II.2. This CM allows interconnectivity as given in Table II.2.

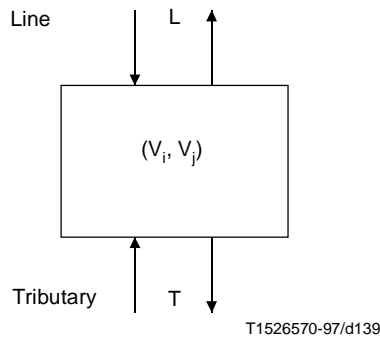

Figure II.2/G.783 – Connection matrix example for 2-port S_n_C

Table II.2/G.783 – Connection matrix example for 2-port type I

		V_i	
		L	T
V_j	L	$i = j$	X
	T	X	$i = j$
<p>X Indicates V_i-V_j connection possible for any i and j.</p> <p>$i = j$ Indicates V_i-V_j connections possible only in the case that $i = j$ (e.g. loopback, no reconfiguration).</p>			

iii) *Connection matrix example for 3-port type I* – The set of input and output ports is divided into three subsets, each containing both input and output ports – West (W), East (E), Drop (D) as shown in Figure II.3. This CM allows interconnectivity between any ports in the subsets, as given in Table II.3.

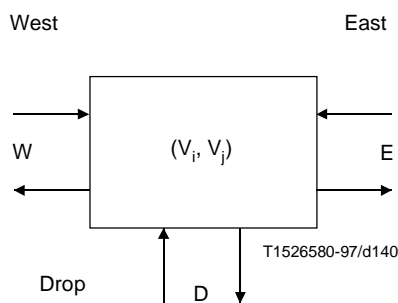

Figure II.3/G.783 – Connection matrix example for 3-port S_n_C

Table II.3/G.783 – Connection matrix example for 3-port type I

		V_i		
		W	E	D
V_j	W	$i = j$	X	X
	E	X	$i = j$	X
	D	X	X	$i = j$

X Indicates V_i - V_j connection possible for any i and j .
 $i = j$ Indicates V_i - V_j connections possible only in the case that $i = j$ (e.g. loopback, no reconfiguration).

iv) *Connection matrix example for 3-port type II* – The set of input and output ports is divided into three subsets, each containing both input and output ports – West (W), East (E), Drop (D) as shown in Figure II.3. This CM allows interconnectivity between the D and W/E ports as shown in Table II.4.

Table II.4/G.783 – Connection matrix example for 3-port type II

		V_i		
		W	E	D
V_j	W	$i = j$	$i = j$	X
	E	$i = j$	$i = j$	X
	D	X	X	$i = j$

X Indicates V_i - V_j connection possible for any i and j .
 $i = j$ Indicates V_i - V_j connections possible only in the case that $i = j$ (e.g. loopback, no reconfiguration).

v) *Connection matrix example for 4-port type I* – The set of input and output ports is divided into four subsets, each containing both input and output ports – West (W), East (E), Drop East (DE), and Drop West (DW) as shown in Figure II.4. This CM allows interconnectivity between any ports in the subsets, as given in Table II.5.

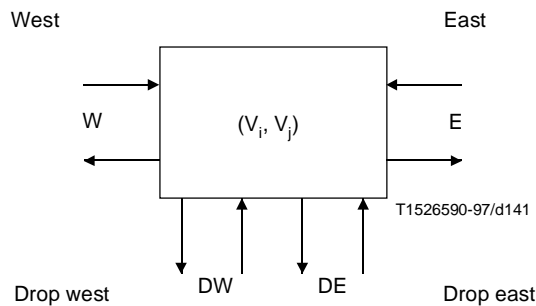

Figure II.4/G.783 – Connection matrix example for 4-port S_n _C

Table II.5/G.783 – Connection matrix example for 4-port type I

		V_i			
		W	E	DW	DE
V_j	W	$i = j$	X	X	–
	E	X	$i = j$	–	X
	DW	X	–	$i = j$	–
	DE	–	X	–	$i = j$

X Indicates V_i - V_j connection possible for any i and j .
 $i = j$ Indicates V_i - V_j connections possible only in the case that $i = j$ (i.e. loopback, no reconfiguration).
 – Indicates no connection possible.

vi) *Connection matrix example for 4-port type II* – The set of input and output ports is divided into four subsets, each containing both input and output ports – West (W), East (E), Drop East (DE), and Drop West (DW) as shown in Figure II.4. This CM allows interconnectivity as given in Table II.6.

Table II.6/G.783 – Connection matrix example for 4-port type II

		V_i			
		W	E	DW	DE
V_j	W	–	$i = j$	X	–
	E	$i = j$	–	–	X
	DW	X	–	–	–
	DE	–	X	–	–

X Indicates V_i - V_j connection possible for any i and j .
 $i = j$ Indicates V_i - V_j connections possible only in the case that $i = j$ (i.e. loopback, no reconfiguration).
 – Indicates no connection possible.

vii) *Connection matrix example for degenerate* – The S_n _C is a null function; i.e. a fixed connection pattern exists between input and output ports (see Figure II.5).

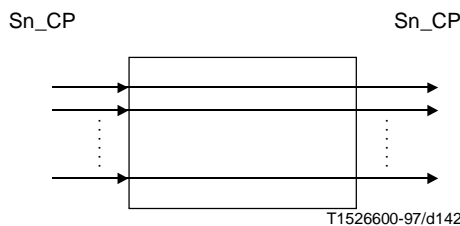

Figure II.5/G.783 – Connection matrix example for degenerate S_n _C

Appendix III

Example of remote indication operation

In order to support single ended operation, the defect status and the number of detected error detection code violations of the characteristic information monitored at the trail termination sink shall be conveyed back to the far-end trail termination source (via RDI and REI signals). Hence, in the case where the terminations lie in the domains of different operators, the Operations Systems (OSs) in both networks will have access to performance information from both trail ends, without the need for OS-to-OS information exchange.

III.1 Remote Defect Indication (RDI)

RDI signals convey the defect status of the trail signal at the trail destination (i.e. at trail termination sink function) back to the trail origin (i.e. trail termination source function). This mechanism allows alignment of the near-end and far-end performance monitoring processes.

Examples of RDI signals are the RDI bits in SDH signals, the A-bit in G.704 structured 2 Mbit/s signals and the alarm indication bit in other PDH multiplex signals.

Figure III.1 illustrates the RDI insertion and detection/processing for a multiplex section. Figure III.2 illustrates the process for a VC-4 path:

- at node A the near-end information represents the performance of the unidirectional section/path from B to A, while the far-end information represents the performance of the unidirectional section/path from A to B;
- at node B the near-end information represents the performance of the unidirectional section/path from A to B, while the far-end information represents the performance of the unidirectional section/path from B to A.

III.2 Remote Error Indication (REI)

REI signals contain either the exact or truncated⁴ number of error detection code violations detected in the trail signal at the trail termination sink. This information is conveyed to the trail termination source. This mechanism allows alignment of the near-end and far-end performance monitoring processes. Examples of REI signals are the REI bits in SDH signals and the E-bit in G.704 structured 2 Mbit/s signals.

Figure III.3 illustrates the REI insertion and extraction/processing for a VC-4 bidirectional path:

- at node A the near-end information represents the performance of the unidirectional path from B to A, while the far-end information represents the performance of the unidirectional path from A to B;
- at node B the near-end information represents the performance of the unidirectional path from A to B, while the far-end information represents the performance of the unidirectional path from B to A.

⁴ Refer to the specific atomic functions to determine between exact or truncated number of EDCV transport in the REI.

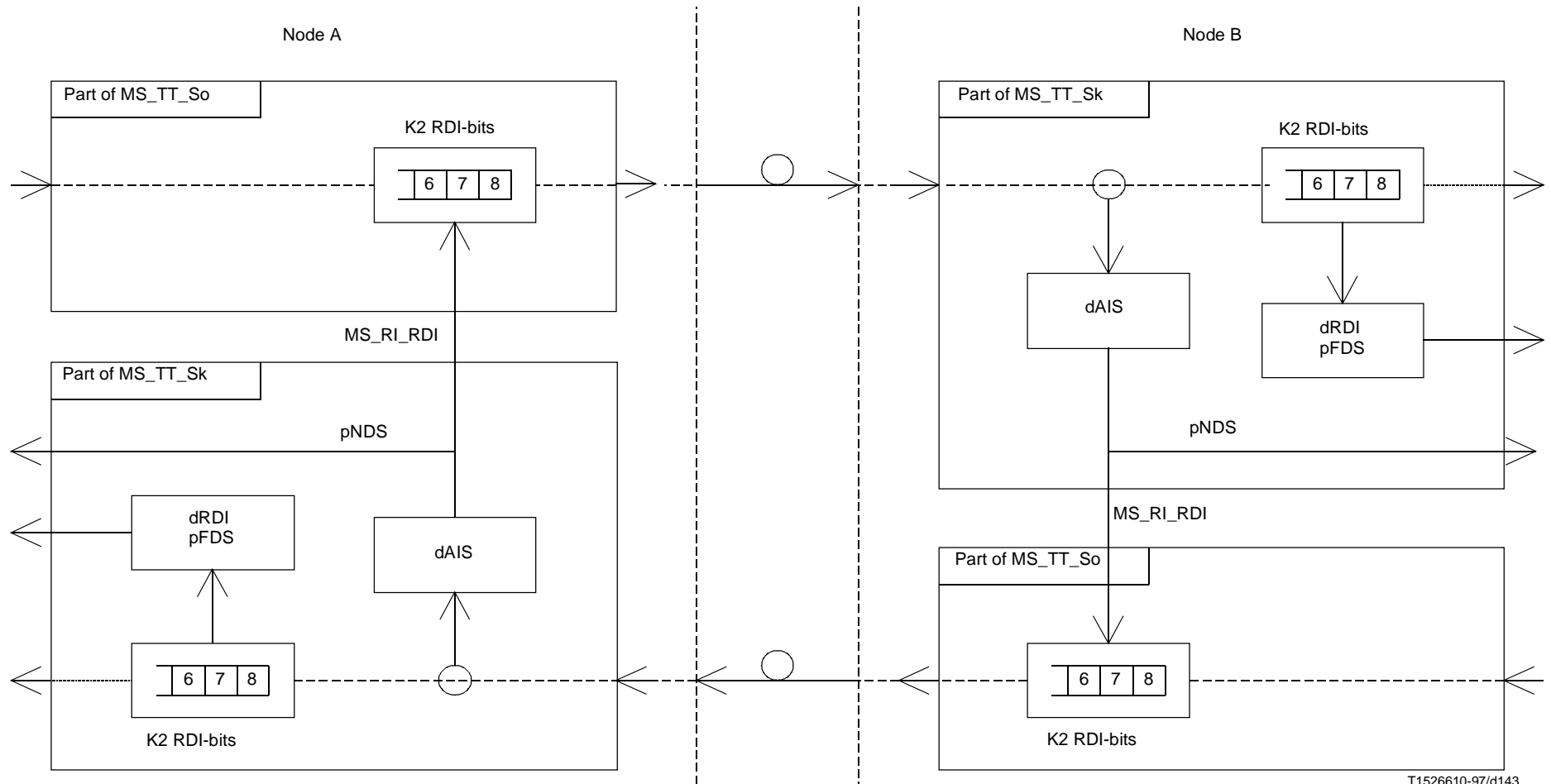

T1526610-97/d143

Figure III.1/G.783 – RDI insertion control example (multiplex section)

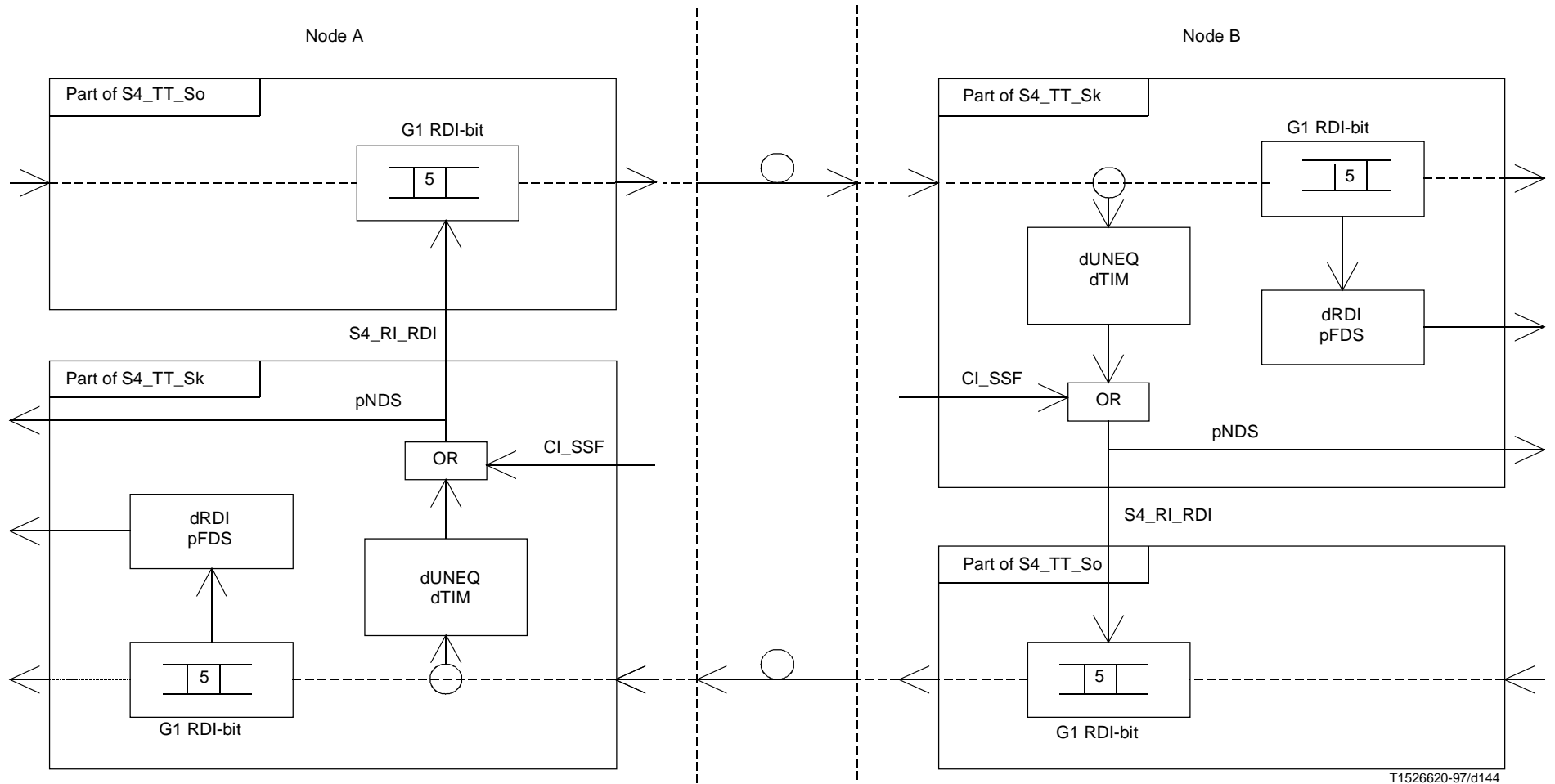

T1526620-97/d144

Figure III.2/G.783 – RDI insertion control example (VC-4 path)

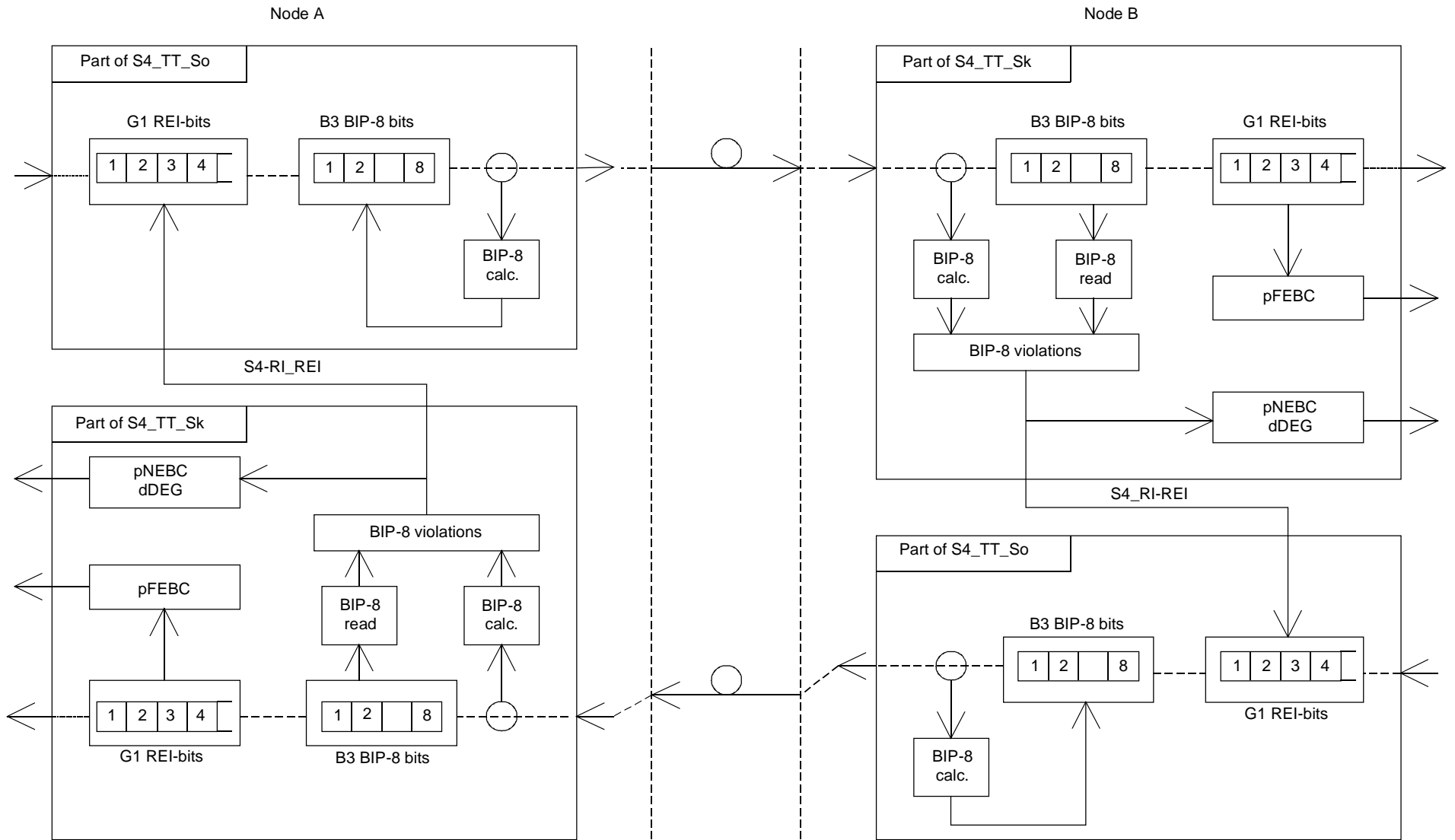

T1526630-97/d145

Figure III.3/G.783 – REI insertion control example (VC-4 path)

Appendix IV

Alarm Indication Signal (AIS)

The AIS is an all-ONES characteristic or adapted information signal. It is generated to replace the normal traffic signal when it contains a defect condition in order to prevent consequential downstream failures being declared and alarms being raised.

All-ONES (AIS) insertion in the sink direction is controlled as follows: every atomic function inserts all-ONES on locally-detected defects only, with one of the defects being incoming AIS from upstream atomic functions.

Figure IV.1 illustrates this process. Due to a LOF defect (STM1dLOF) the OS1/RS1_A_Sk inserts the all-ONES signal. This signal is propagated through the RS1 layer. The MS1/MS1 detects this all-ONES signal by monitoring bits 6-8 of K2. The MS1/S4_A_Sk detects this all-ONES signal by monitoring bits H1, H2. As a consequence both functions insert all-ONES at their outputs (i.e. they "refresh" the all-ONES signal). This behaviour is continued in the other client layers.

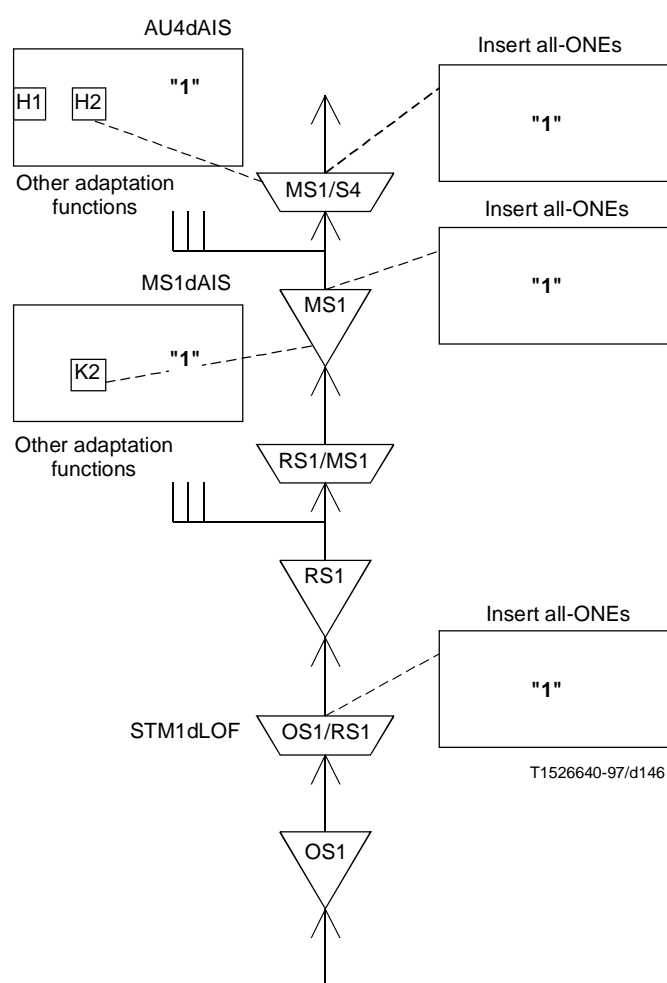

Figure IV.1/G.783 – All-ONES (AIS) insertion and propagation in the sink direction in case of STM1dLOF

As soon as the direction through the layered structure reverts from the sink direction into the source direction, the all-ONES (AIS) signal becomes one of the defined AIS patterns:

- MS_n-AIS (n = 1, 4, 16) in case the RS_n/MS_n_A_Sk is connected to the RS_n/MS_n_A_So. This is the case in an STM-n regenerator;
- AU4-AIS in case the MS_n/S4_A_Sk is connected to the MS_n/S4_A_So. This is the case in a VC-4 Add-Drop Multiplexer and a VC-4 Digital Cross Connect (Figure IV.2);

- Tm-AIS (m = 12, 2, 3) in case the S4/S_m_A_Sk is connected to the S4/S_m_A_So. This is the case in a VC-*m* ADM and a VC-*m* DXC;
- PDH AIS: Ex-AIS, a complete all-ONES signal, in the G.703 type signal.

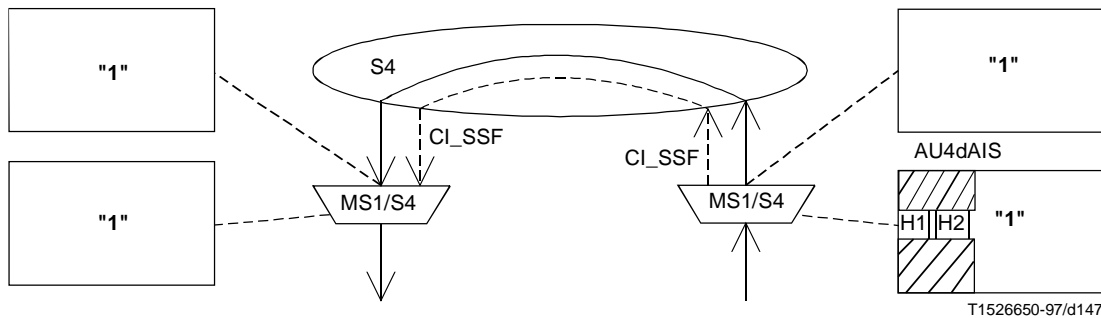

Figure IV.2/G.783 – All-ONES propagation from sink to source direction

The all-ONES and CI_SSF signal applied at the input of the MS1/S4_A_So (Figure IV.3) results in the generation of an all-ONES signal at the output. The MS1_TT_So and the other MS1 adaptation functions (e.g. MS1/OW_A_So) add the MSOH to the all-ONES signal. The RS1_TT_So and the RS1 adaptation functions add the RSOH. The result is the so called AU-4 AIS signal. This signal is transmitted to the far-end. The STM-1 signal passes through the functions up to the MS1_TT_Sk. Then the MS1/S4_A_Sk function detects AU-4 AIS. It declares the AU4dAIS defect and inserts all-ONES at its output.

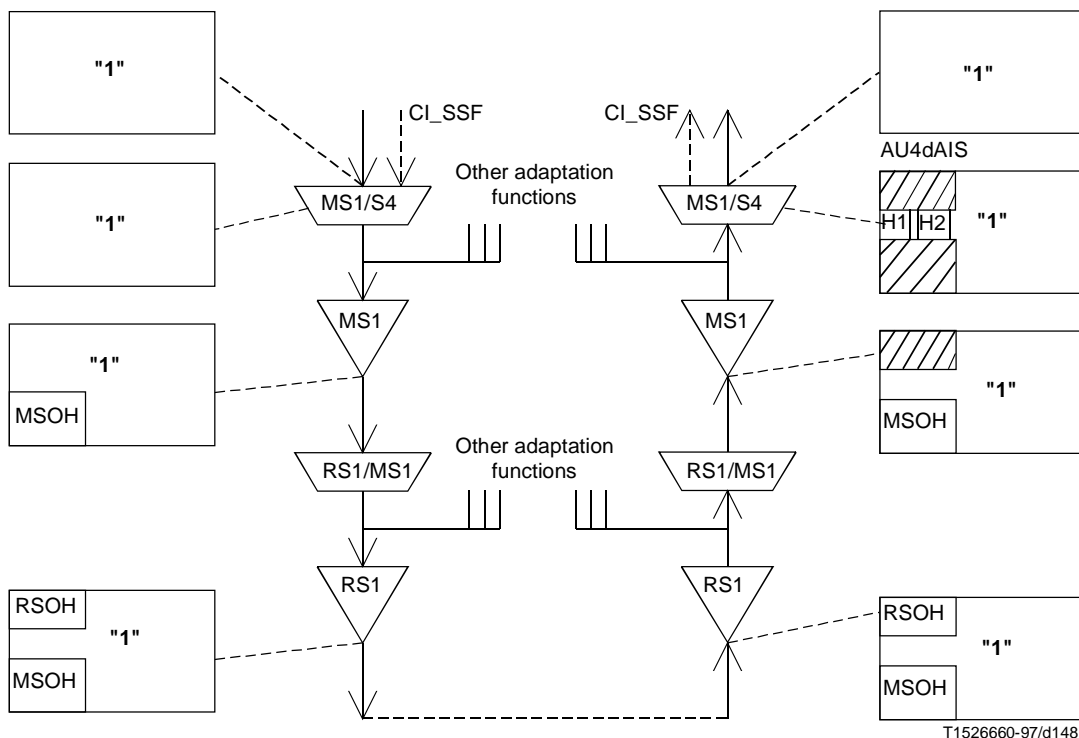

Figure IV.3/G.783 – All-ONES (AIS) generation in the source and detection in the sink direction

Similarly, the reception of an all-ONES signal at the S4/S12_A_So results in the generation of an all-ONES (TU) signal at the output of the function. This signal is multiplexed with the other TUs, after which the VC-4 overhead, AU-4 pointer, MSOH and RSOH are added. The result is an STM-N signal with a TU carrying TU-AIS.

Appendix V

Signal Fail (SF) and Signal Degrade (SD)

V.1 Server Signal Fail (SSF) signal

The CI_SSF signal (generated by the adaptation sink function under control of aSSF) informs the next downstream function of the "signal fail" condition of the associated data signal [which contains, due to that "signal fail" condition, the all-ONEs (AIS) pattern].

The CI_SSF signal, when connected to a connection function with protection functionality, represents the Signal Fail (SF) conditions.

V.2 Server Signal Degrade (aSSD) signal

The CI_SSD signal informs the next downstream function of the "signal degrade" condition of the associated data signal.

The CI_SSD signal is defined only in adaptation sink function in protection sublayers. The signal relays the AI_TSD signal generated by the trail termination sink function towards the protection connection function in the protection sublayer.

V.3 Trail Signal Fail (TSF) signal

The AI_TSF signal (generated by a trail termination sink function under control of aTSF) informs the next downstream function(s) of the "signal fail" condition of the associated data signal [which contains, due to that "signal fail" condition, the all-ONEs (AIS) pattern].

The AI_TSF signal, when connected to a connection function with protection functionality, represents the Signal Fail (SF) conditions.

V.4 Trail Signal Degrade (TSD) signal

The AI_TSD signal (generated by a trail termination sink function under control of aTSD) informs the next function(s) of the "signal degrade" condition of the associated data signal.

The AI_TSD signal is only connected to a connection function with protection functionality, and represents the Signal Degrade (SD) conditions.

Appendix VI

Data Communications Channel (DCC)

The use of the DCC is dependent on the network operator's maintenance strategy and the specific situation. It may not always be required as it is possible to carry out the required functions by other means.

There are two ways of using the DCC:

- i) use of the D1 to D3 bytes located in the RSOH (DCCR) and accessible at regenerators and other network elements;
- ii) use of the D4 to D12 bytes located in the MSOH (DCCM) and not accessible at regenerators. These bytes are provided alternatively across either the P reference point (MCF function), or the U reference point (OHA function). The specific use of the D4 to D12 bytes is for further study.

These channels are message-based and provide communications between network elements. They can be used to support communications between sites and the TMN. Two examples are given in Figures VI.1 and VI.2.

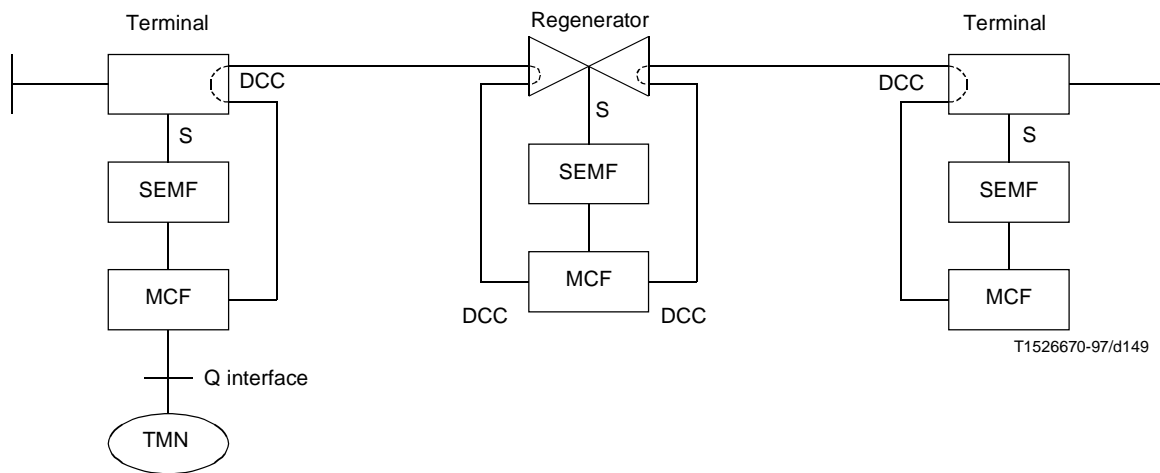

Figure VI.1/G.783 – SDH linear system configuration

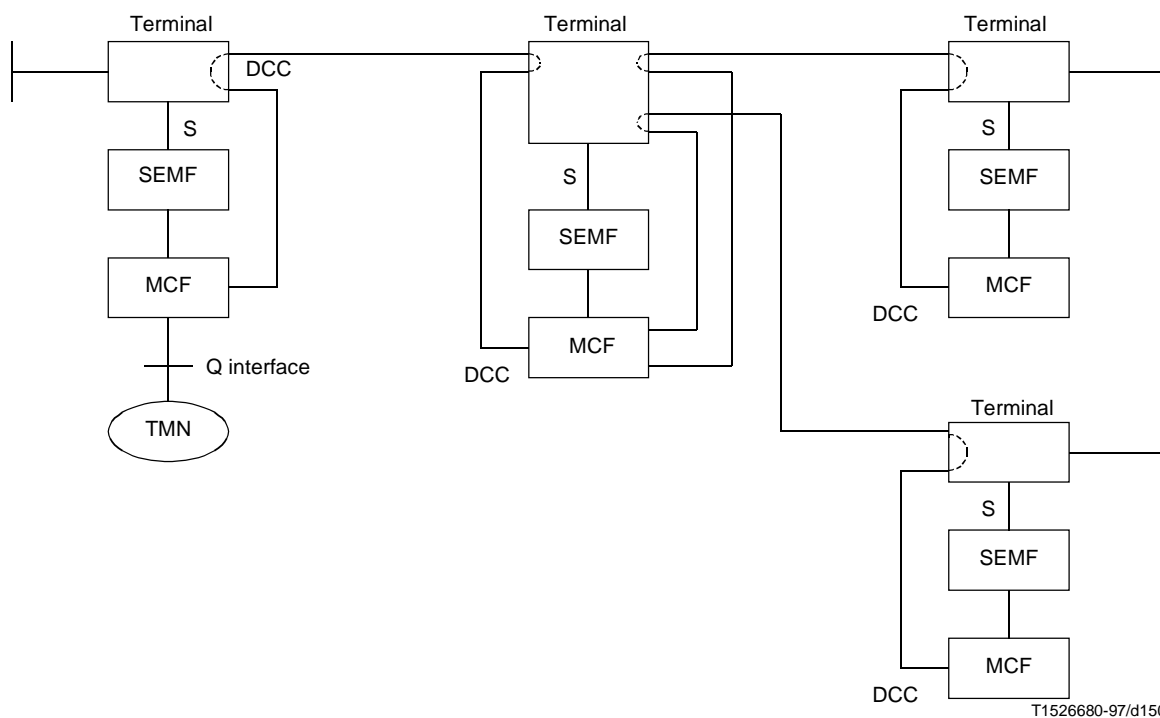
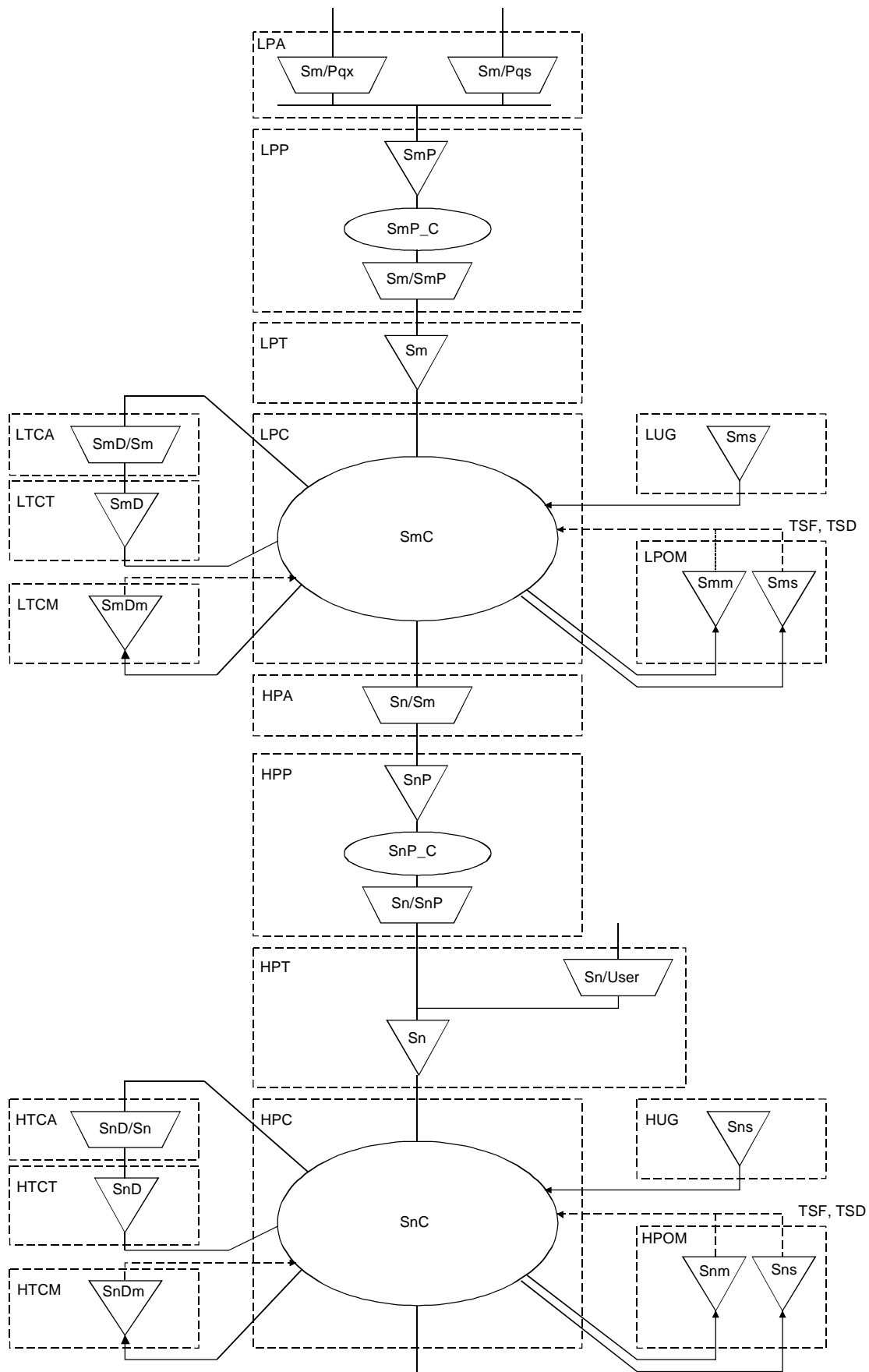

Figure VI.2/G.783 – SDH tree configuration

Appendix VII

Atomic function modelling of basic functions from 1994 G.783

Figure VII.1 illustrates the correspondence between atomic transmission functions defined in this Recommendation and the basic functions described in the 1994 issue of Recommendation G.783. Figure VII.2 illustrates the basic functions for support of the Message Communications Function (MCF) for the DCC. Figure VII.3 illustrates the basic function for user overhead byte access. Figure VII.4 illustrates the basic functions for timing.



T1526690-97/d151

Figure VII.1/G.783 – Atomic function modelling of basic functions for transmission

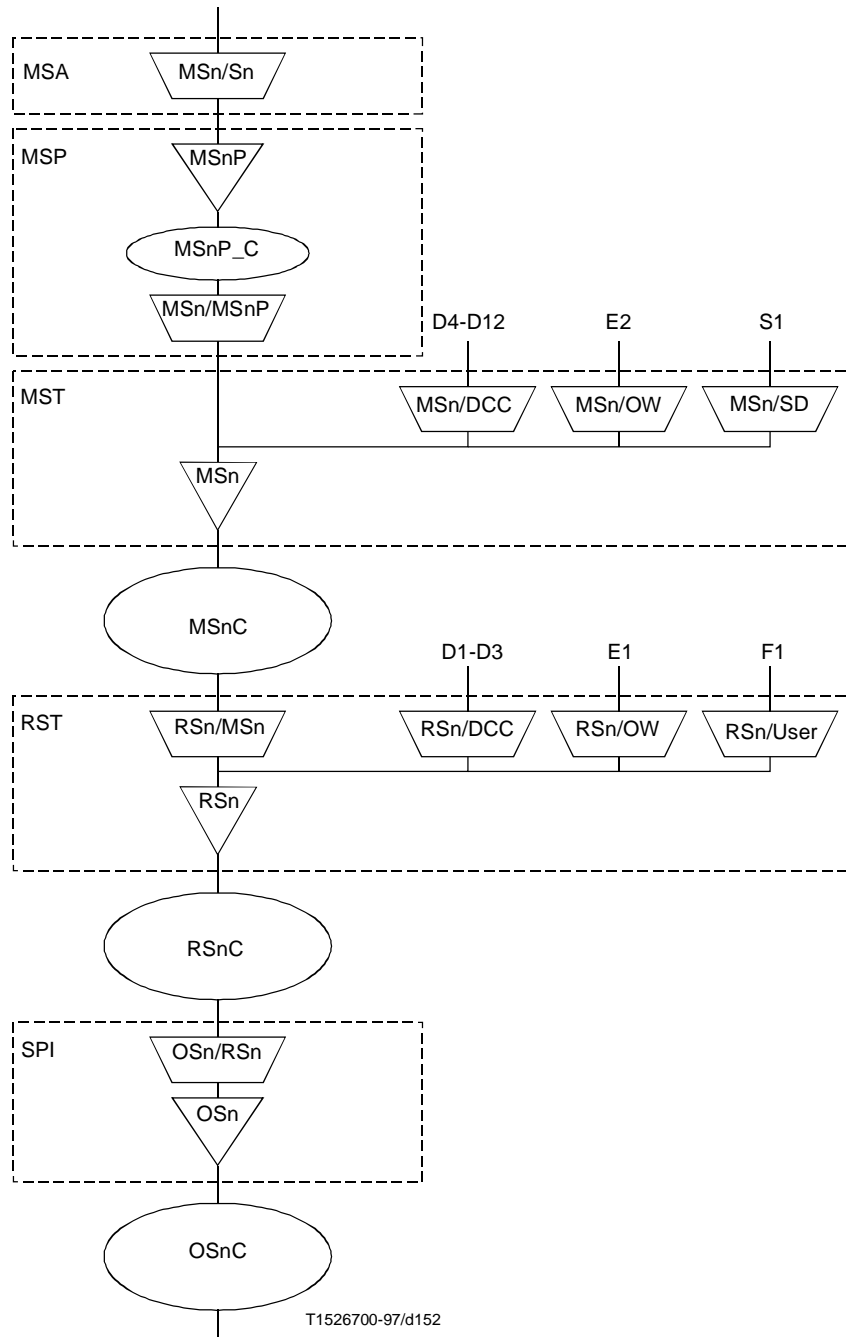

Figure VII.1/G.783 – Atomic function modelling of basic functions for transmission (concluded)

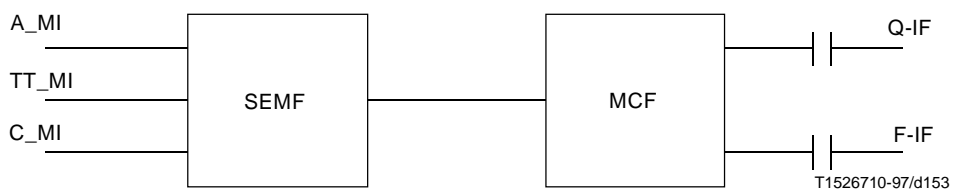

Figure VII.2/G.783 – Basic functions for MCF and DCC

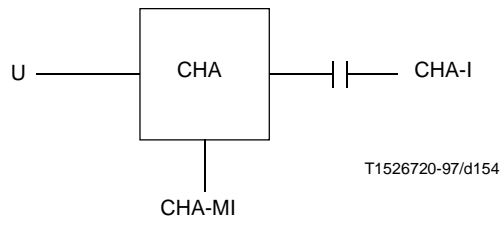

Figure VII.3/G.783 – Basic function for user overhead byte access

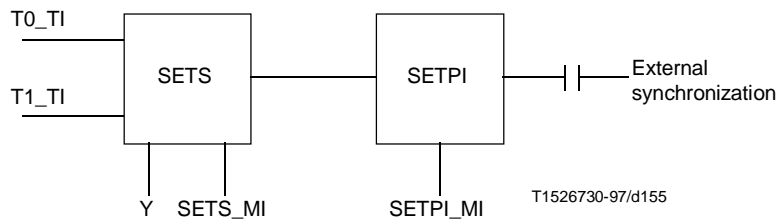

Figure VII.4/G.783 – Basic functions for timing

ITU-T RECOMMENDATIONS SERIES

Series A	Organization of the work of the ITU-T
Series B	Means of expression: definitions, symbols, classification
Series C	General telecommunication statistics
Series D	General tariff principles
Series E	Overall network operation, telephone service, service operation and human factors
Series F	Non-telephone telecommunication services
Series G	Transmission systems and media, digital systems and networks
Series H	Audiovisual and multimedia systems
Series I	Integrated services digital network
Series J	Transmission of television, sound programme and other multimedia signals
Series K	Protection against interference
Series L	Construction, installation and protection of cables and other elements of outside plant
Series M	TMN and network maintenance: international transmission systems, telephone circuits, telegraphy, facsimile and leased circuits
Series N	Maintenance: international sound programme and television transmission circuits
Series O	Specifications of measuring equipment
Series P	Telephone transmission quality, telephone installations, local line networks
Series Q	Switching and signalling
Series R	Telegraph transmission
Series S	Telegraph services terminal equipment
Series T	Terminals for telematic services
Series U	Telegraph switching
Series V	Data communication over the telephone network
Series X	Data networks and open system communication
Series Z	Programming languages