



INTERNATIONAL TELECOMMUNICATION UNION

**ITU-T**

TELECOMMUNICATION  
STANDARDIZATION SECTOR  
OF ITU

**G.735**

**GENERAL ASPECTS OF DIGITAL TRANSMISSION  
SYSTEMS**

**TERMINAL EQUIPMENTS**

---

**CHARACTERISTICS OF PRIMARY PCM  
MULTIPLEX EQUIPMENT OPERATING  
AT 2048 kbit/s AND OFFERING  
SYNCHRONOUS DIGITAL ACCESS  
AT 384 kbit/s AND/OR 64 kbit/s**

**ITU-T Recommendation G.735**

(Extract from the *Blue Book*)

---

## NOTES

1 ITU-T Recommendation G.735 was published in Fascicle III.4 of the *Blue Book*. This file is an extract from the *Blue Book*. While the presentation and layout of the text might be slightly different from the *Blue Book* version, the contents of the file are identical to the *Blue Book* version and copyright conditions remain unchanged (see below).

2 In this Recommendation, the expression “Administration” is used for conciseness to indicate both a telecommunication administration and a recognized operating agency.

## Recommendation G.735

### CHARACTERISTICS OF PRIMARY PCM MULTIPLEX EQUIPMENT OPERATING AT 2048 kbit/s AND OFFERING SYNCHRONOUS DIGITAL ACCESS AT 384 kbit/s AND/OR 64 kbit/s

*(former Recommendation G.737 of Volume III of the Yellow Book)*

This Recommendation gives the characteristics of a PCM multiplex equipment operating at 2048 kbit/s and providing one or several of the following internal digital access options:

- bidirectional synchronous 64 kbit/s channels (see Figure 1 a/G.735);
- unidirectional synchronous 384 kbit/s channels (see Figure 1b/G.735).

The 384 kbit/s channel is based on the allocation of 6 x 64 kbit/s time slots, e.g. for setting up sound-programme circuits according to Recommendations J.41 and J.42.

Because these circuits are specified as unidirectional, the equipment for insertion/extraction has to be separated as shown in Figure 1b/G.735.

#### 1 General characteristics

##### 1.1 *Fundamental characteristics for voice channel encoding*

The encoding law used is the A-law as specified in Recommendation G.711. The sampling rate, load capacity and the code are also specified in that Recommendation.

The number of quantized values is 256.

*Note* - The inversion of bits 2, 4, 6 and 8 is covered by the encoding law and is applicable only to voice channel time slots.

##### 1.2 *Bit rate*

The nominal bit rate is 2048 kbit/s. The tolerance on this rate is  $\pm 50$  parts per million (ppm).

##### 1.3 *Timing signal*

It should be possible to derive the transmit timing signal from any of the following:

- a) from the received 2048 kbit/s signal,
- b) from an external source at 2048 kHz (see § 5),
- c) from an internal oscillator.

*Note* - The provision of a timing signal output, available for the purpose of synchronizing other equipments, is an option that might be required depending upon national synchronization arrangements.

##### 1.4 *Types of access:*

- a) access for bidirectional synchronous 64 kbit/s channels (see Figure 1 a/G.735);
- b) access for unidirectional synchronous 384 kbit/s channels (see Figure 1b/G.735).

*Note* - The synchronous insertion of a digital sound programme signal into a 384 kbit/s channel requires the internal regeneration of a timing signal T synchronized by the 2048 kbit/s signal  $I_1$ . The timing signal is used for

synchronizing the sampling frequency of the analogue/digital converters producing the digital sound programme signal.

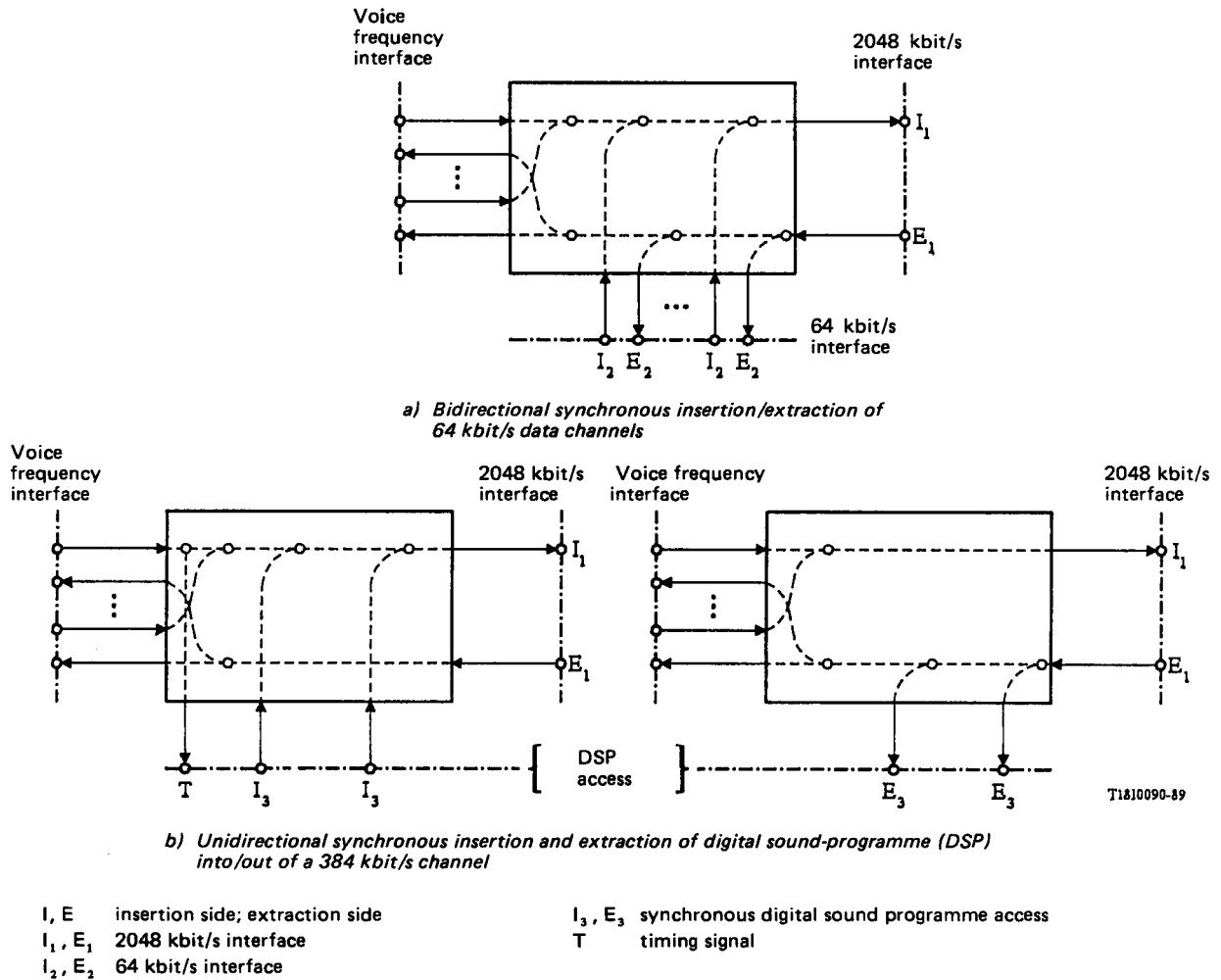

FIGURE 1/G.735

**PCM multiplex equipment operating at 2048 kbit/s and offering access to digital sound-programme signals and/or to synchronous 64 kbit/s data channels**

**2 Frame structure and use of derived channel time slots**

2.1 *Frame structure of 2048 kbit/s signal*

Refer to § 2.3 of Recommendation G.704. Bit 1 of the frame should be used in accordance with § 2.3.3 of Recommendation G.704, i.e. for a CRC check bit procedure.

2.2 *Use of derived channel time slots*

2.2.1 *Telephone channels*

It should be possible to assign channel time slots 1 to 15 and 17 to 31 to thirty telephone channels numbered from 1 to 30.

2.2.2 *64 kbit/s access*

The number of accessible channel time slots should be at least four and the equipment shall allow access to any

of channel time slots 1 to 15 and 17 to 31.

*Note* - Equipment exists which provides access to at least four channel time slots in the following order of priority: 6 - 22 - 14 - 30 - 2 - 18 - 10 - 26 - 4 - 20 - 12 - 28 - 8 - 24 - 5 - 21 - 13 - 29 - 1 - 17 - 9 - 25 - 3 - 19 - 11 - 27 - 7 - 23 - 15 - 31.

### 2.2.3 384 kbit/s access

The time slot allocation for digital channels with a bit rate at 384 kbit/s is given in Table 1/G.735.

TABLE 1/G.735

384 kbit/s channels (Note 1)					Digital sound-programme access points
A	B	C	D	E	
1-2-3 17-18-19	4-5-6 20-21-22	7-8-9 23-24-25	10-11-12 26-27-28	13-14-15 29-30-31	I3, T, E3 Figure 1b/G.735

*Note 1* - The five possible 384 kbit/s channels in a 2048 kbit/s stream are numbered A to E. Preferably the channel pairs A-B and C-D should be used for stereophonic transmission.

*Note 2* - If the channel time slot 16 which is assigned to signalling as covered in § 5 is not needed for signalling, it may be used for purposes other than a voice channel encoded within the PCM multiplex equipment.

## 3 Frame alignment and CRC procedures

An illustration of the procedure is given in Figure 2/G.706.

### 3.1 Loss of frame alignment

Refer to § 4.1.1 of Recommendation G.706.

### 3.2 Recovery of frame alignment

Refer to § 4.1.2 of Recommendation G.706.

### 3.3 CRC multiframe alignment in TSO

Refer to § 4.2 of Recommendation G.706.

### 3.4 CRC bit monitoring

Refer to § 4.3 of Recommendation G.706.

## 4 Fault conditions and consequent actions

### 4.1 Fault conditions

The PCM multiplex equipment should detect the following fault conditions:

#### 4.1.1 Failure of power supply.

#### 4.1.2 Failure of codec (except when using single channel codecs).

As a minimum requirement, this fault condition should be recognized when for at least one signal level in the range -21 to -6 dBm0, the signal-to-quantizing noise ratio performance of the local codec is 18 dB or more below the level recommended in Recommendation G.712.

4.1.3 Loss of incoming signals at the 64 kbit/s and 384 kbit/s tributary input ports.

*Note 1* - This detection is not mandatory when contradirectional interfaces are used.

*Note 2* - The detection of this fault condition is not mandatory for channel time slot 16 when channel associated signalling is used and the signalling multiplex equipment is situated within a few metres of the PCM multiplex equipment.

4.1.4 Loss of the incoming signal at 2048 kbit/s.

*Note 1* - The detection of this fault condition is required only when it does not result in an indication of loss of frame alignment.

*Note 2* - Where separate circuits are used for the digital signal and the timing signal, the loss of either or both should constitute loss of the incoming signal.

4.1.5 Loss of frame alignment.

4.1.6 Excessive bit error ratio detected by monitoring the frame alignment signal.

4.1.6.1 With a random bit error ratio of  $\leq 10^{-4}$ , the probability of activating the indication of fault condition within a few seconds should be less than  $10^{-6}$ .

With a random bit error ratio of  $\geq 10^{-3}$ , the probability of activating the indication of fault condition within a few seconds should be higher than 0.95.

4.1.6.2 With a random bit error ratio of  $\geq 10^{-3}$ , the probability of deactivating the indication of fault condition within a few seconds should be almost 0.

With a random bit error ratio of  $\leq 10^{-4}$ , the probability of deactivating the indication of fault condition within a few seconds should be higher than 0.95.

*Note* - The activating and the deactivating period specified as "a few seconds" is intended to be in the order of 4 to 5 seconds.

4.1.7 Alarm indication received from the remote PCM multiplex equipment (see § 4.2.3).

## 4.2 *Consequent actions*

Further to the detection of a fault condition, appropriate actions should be taken as specified in Table 2/G.735. The consequent actions are as follows:

4.2.1 Service alarm indication generated to signify that the service provided by the PCM multiplex is no longer available. This indication should be forwarded at least to the switching and/or signalling multiplex equipment depending upon the arrangements provided. The indication should be given as soon as possible and not later than 2 ms after detection of the relevant fault condition..

This specification, taking into account the specification given in § 4.2.5, is equivalent to recommending that the average time to detect a loss of frame alignment or a loss of the incoming 2048 kbit/s signal and to give the relevant indication should not be greater than 3 ms.

When using common channel signalling the indication should be forwarded to the switching equipment by means of a separate interface on the PCM multiplex equipment.

4.2.2 Prompt maintenance alarm indication generated to signify that performance is below acceptable standards and maintenance attention is required locally. When the AIS (see General Notes below to § 4.2) at 2048 kbit/s input is detected, the prompt maintenance alarm indication associated with loss of frame alignment (see § 4.1.5) and excessive error ratio (see § 4.1.6) should be inhibited, while the rest of the consequent actions are in accordance with those associated in Table 2/G.735 with the two fault conditions.

*Note* - The location and provision of any visual and/or audible alarm activated by the alarm indications given in §§ 4.2.1 and 4.2.2, is left to the discretion of each Administration.

4.2.3 Alarm indication to the remote end transmitted by changing bit 3 of channel time slot 0 from the state 0 to the state 1 in those frames not containing the frame alignment signal. This should be effected as soon as possible.

4.2.4 Transmission suppressed at the analogue voice-frequency outputs.

4.2.5 AIS applied to all 64 kbit/s and 384 kbit/s outputs (see General Notes below § 4.2). For 64 kbit/s outputs, this action should be taken as soon as possible and not later than two ms after the detection of the fault condition.

4.2.6 AIS applied to relevant time slots in the composite 2048 kbit/s output signal (if suspension of incoming 64 kbit/s and/or 384 kbit/s signals is provided).

*General Notes to § 4.2*

*Note 1* - The equivalent binary content of the alarm indication signal (AIS) is a continuous stream of binary 1s. The strategy for detecting the presence of the AIS should be such that with a high probability the AIS is detectable even in the presence of random errors having a mean error rate of 1 in  $10^3$ . Nevertheless, a signal in which all the binary elements, with the exception of the frame alignment signal, are in the state 1, should not be taken as an AIS.

*Note 2* - All timing requirements quoted apply equally to restoration, subsequent to the fault condition clearing.

## **5 Signalling**

Text as in Recommendation G.732.

## **6 Interfaces**

### *6.1 Audio frequency interface*

The analogue audio frequency interfaces should be in accordance with Recommendations G.712, G.713, G.714 and G.715.

### *6.2 Digital interfaces*

The digital interfaces at 2048 kbit/s should be in accordance with Recommendation G.703.

The digital interfaces at 64 kbit/s should be of either the codirectional or the contradirectional type specified in Recommendation G.703. The specifications for 64 kbit/s interfaces are not mandatory for channel associated signalling. The interface for external synchronization of the transmitting timing signal should be in accordance with Recommendation G.703.

The need to define a digital interface operating at 384 kbit/s is under study.

*Note 1* - It should be noted that, according to the principle of minimizing the number of different types of interfaces, the information rate of 384 kbit/s will be offered to customers at the user/network interface level using the 2048 kbit/s interface as defined in Recommendations I.431 and G.703.

*Note 2* - In the case of the 64 kbit/s codirectional interface, the design of the input ports should take account of the need to provide octet alignment, to allow controlled slips when the tributary timing and that of the multiplexer timing source are plesiochronous, and to absorb jitter and wander up to the limits given in Recommendation G.823.

TABLE 2/G.735

## Fault conditions and consequent actions for the PCM multiplex equipment

Equipment part	Fault conditions (see § 4.1)	Consequent actions (see § 4.2)					
		Service alarm indication generated	Prompt maintenance alarm indication generated	Alarm indication remote end transmitted	Transmission suppressed at the analogue voice-frequency outputs	AIS applied to all 64 kbit/s and 384 kbit/s outputs	AIS to the relevant time slot of the 2048 kbit/s composite signal
Multiplexer and demultiplexer	Failure of power supply	Yes	Yes	Yes (if practicable)	Yes (if practicable)	Yes (if practicable)	Yes (if practicable)
	Failure of codec	Yes	Yes	Yes	Yes		
Multiplexer only	Loss of incoming signal at 64 kbit/s and/or 384 kbit/s inputs (see Note under § 4.1.3)		Yes				Yes
Demultiplexer only	Loss of incoming signal at 2048 kbit/s	Yes	Yes	Yes	Yes	Yes	
	Loss of frame alignment (see Note 2 of Rec. G.706, § 4.2)	Yes	Yes (see § 4.2.2)	Yes	Yes	Yes	
	Error ratio $1 \cdot 10^{-3}$ on the frame alignment signal	Yes	Yes (see § 4.2.2)	Yes	Yes	Yes	
	Alarm indication received from the remote end	Yes					

*Note* - A *Yes* in the table signifies that an action should be taken as a consequence of the relevant fault condition. An *open space* in the table signifies that the relevant action should *not* be taken as a consequence of the relevant fault condition, if this condition is the only one present. If more than one fault condition is simultaneously present, the relevant action should be taken if, for at least one of the conditions, a *Yes* is defined in relation to this action.



## 7.1 *Jitter at 2048 kbit/s output*

7.1.1 In the case where the transmitting timing signal is derived from an internal oscillator, the peak-to-peak jitter at the 2048 kbit/s output should not exceed 0.05 UI when it is measured within the frequency range from  $f_1 = 20$  Hz to  $f_4 = 100$  kHz. See Figure 2/G.823.

7.1.2 In the case where the transmitting timing signal is derived from an external source having no jitter, the peak-to-peak jitter at the 2048 kbit/s output should not exceed 0.05 UI when it is measured within the frequency range from  $f_1 = 20$  Hz to  $f_4 = 100$  kHz.

7.1.3 In the case where the transmitting timing signal is derived from the incoming 2048 kbit/s signal having no jitter, the peak-to-peak jitter at the 2048 kbit/s output should not exceed 0.10 UI when it is measured within the frequency range from  $f_1 = 20$  Hz to  $f_4 = 100$  kHz. The equivalent binary content of the test signal applied at the 2048 kbit/s input shall be a pseudo-random bit sequence of length  $2^{15} - 1$  as specified in Recommendation O.151.

Note - It may be necessary to include a frame alignment signal in the test signal to enable the measurement to be carried out.

## 7.2 *Jitter at tributary outputs*

### 7.2.1 *Jitter at 64 kbit/s output*

In the case where the incoming 2048 kbit/s signal has no jitter, the peak-to-peak jitter at the 64 kbit/s output should not exceed 0.025 UI when it is measured within the frequency range from  $f_1 = 20$  Hz to  $f_4 = 10$  kHz. The equivalent binary content of the test signal applied to the 2048 kbit/s input shall be a pseudo-random bit sequence of length  $2^{15} - 1$  as specified in Recommendation O.151

Note - In order to carry out this measurement without invoking AIS at the 64 kbit/s output, it will normally be necessary to include a frame alignment signal in the test signal.

### 7.2.2 *Jitter at 384 kbit/s output*

Since the physical and electrical characteristics of a 384 kbit/s interface are identical to those of the 2048 kbit/s interface, the specification of this parameter is the same as that given in § 7.1.3 above.

## 7.3 *Jitter transfer functions*

7.3.1 The jitter transfer function between the 2048 kHz external synchronisation signal and the 2048 kbit/s output signal should not exceed the gain/frequency limits given in Figure 2/G.735. The 2048 kHz signal shall be modulated with sinusoidal jitter.

Some Administrations require that equipment be fitted with jitter reducers. In this case, the jitter transfer junction should not exceed the gain/frequency limits given in Figure 3/G.735.

7.3.2 In the case where the transmitting timing is derived from the incoming signal, the jitter transfer junction between the 2048 kbit/s input and 2048 kbit/s output shall be as specified in § 7.3.1.

Note 1 - The 2048 kbit/s test signal shall be modulated by sinusoidal jitter. The equivalent binary content of the test signal shall be 1000.

Note 2 - It may be necessary to include a frame alignment signal in the test signal to enable the measurement to be carried out.

7.3.3 The jitter transfer function between the 2048 kbit/s and the 64 kbit/s output should not exceed -29.6 dB when measured over the frequency range  $f_0$  to 10 kHz. The frequency  $f_0$  should be less than 20 Hz and as low as possible (e.g. 10 Hz), taking into account the limitations of measuring equipment.

*Note 1* - The 2048 kbit/s test signal shall be modulated by sinusoidal jitter. The equivalent binary content of the test signal shall be 1000.

*Note 2* - In order to carry out this measurement without invoking AIS at the 64 kbit/s output, it will normally be necessary to include a frame alignment signal in the test signal.

*Note 3* - The jitter reduction of 1/32 due to demultiplexing is equivalent to -30.1 dB.

7.3.4 Since the physical and electrical characteristics of a 384 kbit/s interface are identical to those of the 2048 kbit/s interface, the jitter transfer function between the 2048 kbit/s input and the 384 kbit/s output is the same as that given in §§ 7.3.1 and 7.3.2 above.

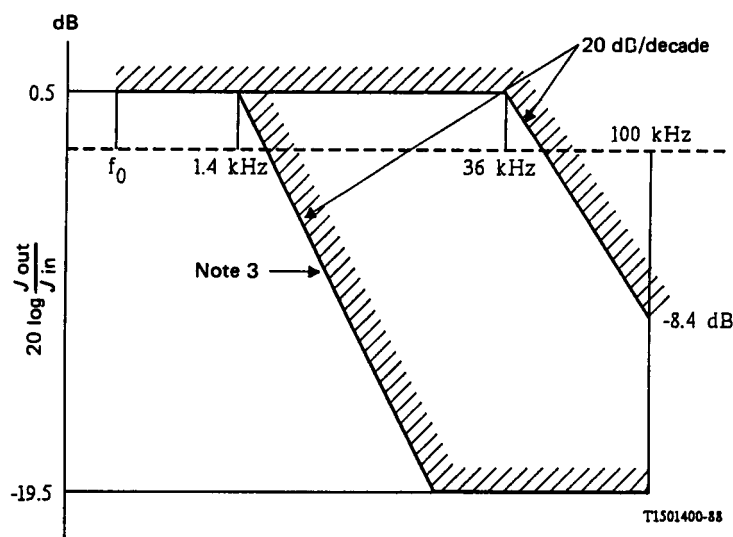

*Note 1* - The frequency  $f_0$  should be less than 20 Hz and as low as possible (e.g. 10 Hz), taking into account the limitations of measuring equipment.

*Note 2* - To achieve accurate measurements, the use of a selective method is recommended with a bandwidth sufficiently small referred to the relevant measurement frequency but not wider than 40 Hz.

*Note 3* - For interfaces within national boundaries, this characteristic may be used

FIGURE 2/G.735

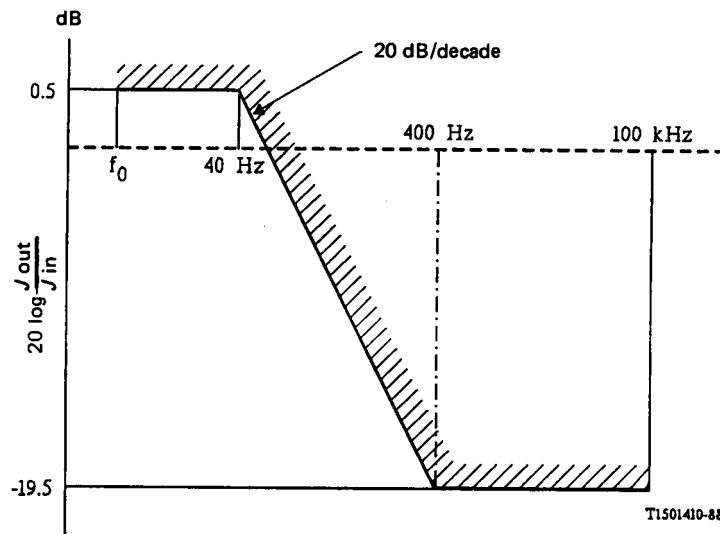

*Note 1* - The frequency  $f_0$  should be less than 20 Hz and as low as possible (e.g. 10 Hz), taking into account the limitations of measuring equipment.

*Note 2* - To achieve accurate measurements, the use of a selective method is recommended with a bandwidth sufficiently small referred to the relevant measurement frequency, but not wider than 40 Hz.

FIGURE 3/G.735