



INTERNATIONAL TELECOMMUNICATION UNION

ITU-T

TELECOMMUNICATION
STANDARDIZATION SECTOR
OF ITU

G.169

(06/99)

SERIES G: TRANSMISSION SYSTEMS AND MEDIA,
DIGITAL SYSTEMS AND NETWORKS

International telephone connections and circuits –
Apparatus associated with long-distance telephone circuits

Automatic level control devices

ITU-T Recommendation G.169

(Previously CCITT Recommendation)

ITU-T G-SERIES RECOMMENDATIONS

TRANSMISSION SYSTEMS AND MEDIA, DIGITAL SYSTEMS AND NETWORKS

INTERNATIONAL TELEPHONE CONNECTIONS AND CIRCUITS	G.100–G.199
General definitions	G.100–G.109
General Recommendations on the transmission quality for an entire international telephone connection	G.110–G.119
General characteristics of national systems forming part of international connections	G.120–G.129
General characteristics of the 4-wire chain formed by the international circuits and national extension circuits	G.130–G.139
General characteristics of the 4-wire chain of international circuits; international transit	G.140–G.149
General characteristics of international telephone circuits and national extension circuits	G.150–G.159
Apparatus associated with long-distance telephone circuits	G.160–G.169
Transmission plan aspects of special circuits and connections using the international telephone connection network	G.170–G.179
Protection and restoration of transmission systems	G.180–G.189
Software tools for transmission systems	G.190–G.199
INTERNATIONAL ANALOGUE CARRIER SYSTEM	
GENERAL CHARACTERISTICS COMMON TO ALL ANALOGUE CARRIER-TRANSMISSION SYSTEMS	G.200–G.299
INDIVIDUAL CHARACTERISTICS OF INTERNATIONAL CARRIER TELEPHONE SYSTEMS ON METALLIC LINES	G.300–G.399
GENERAL CHARACTERISTICS OF INTERNATIONAL CARRIER TELEPHONE SYSTEMS ON RADIO-RELAY OR SATELLITE LINKS AND INTERCONNECTION WITH METALLIC LINES	G.400–G.449
COORDINATION OF RADIOTELEPHONY AND LINE TELEPHONY	G.450–G.499
TESTING EQUIPMENTS	
TRANSMISSION MEDIA CHARACTERISTICS	
DIGITAL TRANSMISSION SYSTEMS	
TERMINAL EQUIPMENTS	G.700–G.799
DIGITAL NETWORKS	G.800–G.899
DIGITAL SECTIONS AND DIGITAL LINE SYSTEM	G.900–G.999

For further details, please refer to ITU-T List of Recommendations.

ITU-T RECOMMENDATION G.169

AUTOMATIC LEVEL CONTROL DEVICES

Summary

This Recommendation applies to testing of Automatic Level Control (ALC) devices intended for use in digital network-based equipment. It **does not** apply to subscriber-based level control devices, devices that operate in the analogue domain, or any means of fixed level control within the network which may be part of an overall network transmission plan.

The scope of this Recommendation is to define certain performance constraints for network ALC devices and, where appropriate, to define laboratory tests that may be performed on an ALC device to verify that these constraints are met.

An ALC device that satisfies all the constraints and passes all of the tests in this Recommendation should ensure (but will not guarantee) that the pre-existing standard of overall network performance (e.g. the transmission of speech, voiceband data and other voiceband signals, ISDN, etc.) is not degraded when the ALC device is installed in the network.

This Recommendation also describes the general characteristics of ALC devices and indicates what characteristics are important to provide acceptable performance in the network. Issues relating to the interaction of ALC devices with other network and subscriber equipment are also discussed in this Recommendation.

This Recommendation **does not** define a standard algorithm.

This Recommendation **does not** define planning rules, deployment aspects, or target levels for ALC devices.

Source

ITU-T Recommendation G.169 was prepared by ITU-T Study Group 15 (1997-2000) and was approved under the WTSC Resolution No. 1 procedure on the 22nd of June 1999.

FOREWORD

ITU (International Telecommunication Union) is the United Nations Specialized Agency in the field of telecommunications. The ITU Telecommunication Standardization Sector (ITU-T) is a permanent organ of the ITU. The ITU-T is responsible for studying technical, operating and tariff questions and issuing Recommendations on them with a view to standardizing telecommunications on a worldwide basis.

The World Telecommunication Standardization Conference (WTSC), which meets every four years, establishes the topics for study by the ITU-T Study Groups which, in their turn, produce Recommendations on these topics.

The approval of Recommendations by the Members of the ITU-T is covered by the procedure laid down in WTSC Resolution No. 1.

In some areas of information technology which fall within ITU-T's purview, the necessary standards are prepared on a collaborative basis with ISO and IEC.

NOTE

In this Recommendation the term *recognized operating agency (ROA)* includes any individual, company, corporation or governmental organization that operates a public correspondence service. The terms *Administration*, *ROA* and *public correspondence* are defined in the *Constitution of the ITU (Geneva, 1992)*.

INTELLECTUAL PROPERTY RIGHTS

The ITU draws attention to the possibility that the practice or implementation of this Recommendation may involve the use of a claimed Intellectual Property Right. The ITU takes no position concerning the evidence, validity or applicability of claimed Intellectual Property Rights, whether asserted by ITU members or others outside of the Recommendation development process.

As of the date of approval of this Recommendation, the ITU had not received notice of intellectual property, protected by patents, which may be required to implement this Recommendation. However, implementors are cautioned that this may not represent the latest information and are therefore strongly urged to consult the TSB patent database.

© ITU 1999

All rights reserved. No part of this publication may be reproduced or utilized in any form or by any means, electronic or mechanical, including photocopying and microfilm, without permission in writing from the ITU.

CONTENTS

	Page
1 Scope.....	1
2 References.....	1
3 Terms and definitions	2
4 Abbreviations and acronyms	3
5 Characteristics of ALC devices	3
5.1 General.....	3
5.2 ALC characteristics.....	3
5.3 Tandemed operation	4
5.4 Delay performance.....	4
6 Test signals	4
6.1 Test signal for level and gain checks.....	4
6.2 Electrical circuit noise	5
6.3 Environmental noise	5
7 Tests	5
7.1 Stability.....	6
7.1.1 Networks without pre-existing echo control	6
7.1.2 Networks with echo control.....	7
7.2 Echo	7
7.3 Noise tolerance	10
7.4 Signalling tones.....	12
7.4.1 DTMF tests.....	12
7.5 Voiceband data and facsimile transmission.....	15
7.5.1 Disabler characteristics.....	15
7.5.2 Tests to confirm satisfactory voiceband data and fax performance when an ALC device is not disabled by 2100 Hz	17
Annex A – Guidance for measuring signal levels in networks.....	19
Appendix I – Guidance for the design of Automatic Level Control (ALC) algorithms and their placement in the PSTN.....	20
I.1 Introduction.....	20
I.2 Discussion.....	20
I.3 ALC considerations	21

	Page
I.3.1 Location of ALC.....	21
I.3.2 Algorithmic and subjective considerations	22
I.3.3 Equipment issues	23
I.3.4 Echo	23
I.3.5 Loop stability.....	23
Appendix II – Considerations relating to ALC deployment.....	24
II.1 Location of ALC.....	24
II.2 Tandemed operation	25

Recommendation G.169

AUTOMATIC LEVEL CONTROL DEVICES

(Geneva, 1999)

1 Scope

This Recommendation applies to testing of Automatic Level Control (ALC) devices intended for use in digital network-based equipment.

An ALC device is defined as any signal processing function located in the digital transmission path which automatically adjusts the level of a signal towards a predetermined value. Devices which modify the frequency response or spectral content of the signal in such a way as to affect the overall level of the signal are also defined as ALC devices for the purpose of this Recommendation.

This Recommendation does not apply to subscriber-based level control devices, devices that operate in the analogue domain, or any means of fixed level control within the network which may be part of an overall network transmission plan.

The scope of this Recommendation is to define certain performance constraints for network ALC devices and, where appropriate, to define laboratory tests that may be performed on an ALC device to verify that these constraints are met.

An ALC device that satisfies all the constraints and passes all of the tests in this Recommendation should ensure (but will not guarantee) that the pre-existing standard of overall network performance (e.g. the transmission of speech, voiceband data and other voiceband signals, ISDN, etc.) is not degraded when the ALC device is installed in the network.

This Recommendation also describes the general characteristics of ALC devices and indicates what characteristics are important to provide acceptable performance in the network. Issues relating to the interaction of ALC devices with other network and subscriber equipment are also discussed in this Recommendation.

This Recommendation **does not** define a standard algorithm.

This Recommendation **does not** define planning rules, deployment aspects, or target levels for ALC devices. This information may be found in Recommendations currently under development in ITU-T Study Group 12.

2 References

The following ITU-T Recommendations and other references contain provisions which, through reference in this text, constitute provisions of this Recommendation. At the time of publication, the editions indicated were valid. All Recommendations and other references are subject to revision; all users of this Recommendation are therefore encouraged to investigate the possibility of applying the most recent edition of the Recommendations and other references listed below. A list of the currently valid ITU-T Recommendations is regularly published.

- [1] ITU-T Recommendation P.56 (1993), *Objective measurement of active speech level*.
- [2] ITU-T Recommendation G.122 (1993), *Influence of national systems on stability and talker echo in international connections*.
- [3] CCITT Recommendation G.164 (1988), *Echo suppressors*.
- [4] ITU-T Recommendation G.165 (1993), *Echo Cancellers*.

- [5] ITU-T Recommendation V.8 (1998), Procedures for starting sessions of data transmission over the public switched telephone network.
- [6] ITU-T Recommendation V.25 (1996), *Automatic answering equipment and general procedures for automatic calling equipment on the general switched telephone network including procedures for disabling of echo control devices for both manually and automatically established calls.*
- [7] ITU-T Recommendation T.30 (1996), *Procedures for document facsimile transmission in the general switched telephone network.*
- [8] ITU-T Recommendation T.4 (1996), *Standardization of Group 3 Facsimile terminals for document transmission.*
- [9] ITU-T Recommendation G.168 (1997), *Digital network echo cancellers.*
- [10] ITU-T Recommendation P.561 (1996), *In-service non-intrusive measurement device – Voice service measurements.*
- [11] ITU-T Recommendation P.501 (1996), *Test signals for use in Telephony.*
- [12] CCITT Recommendation Q.24 (1988), *Multifrequency push-button signal reception.*

3 Terms and definitions

This Recommendation defines the following terms:

3.1 ALC device: A signal processing function located in the digital transmission path which automatically adjusts the level of a signal towards a predetermined value. Devices which modify the frequency response or spectral content of the signal in such a way as to affect the overall level of the signal are also defined as ALC devices for the purpose of this Recommendation. An ALC device is designed to process signals in one direction of transmission. See Figure 1.

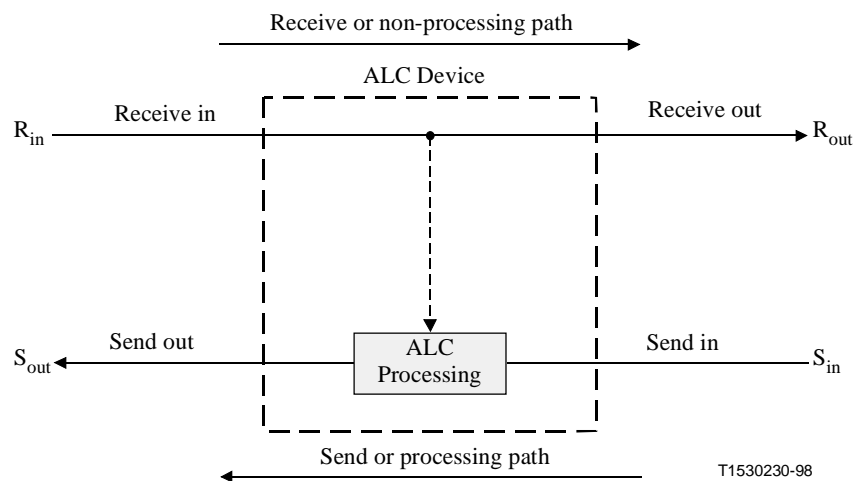

Figure 1/G.169 – Block diagram of an ALC device

3.2 Disabled ALC device: An ALC device that has been forced into a 64 kbit/s bit-sequence integrity mode of operation, by whatever means.

3.3 Echo canceller: A device placed in the 4-wire portion of a circuit and used for reducing cancelled-end echo present on the send path by subtracting an estimation of that echo from the cancelled-end echo.

3.4 Full ALC device: An ALC device designed to process signals in both directions of transmission.

3.5 Full echo canceller: An echo canceller designed to cancel echoes in both directions (i.e. near-end and far-end echoes).

3.6 Laboratory tests: Tests which may be performed in a laboratory or any environment where the ALC device is not installed in the network and is therefore not 'in service'.

3.7 Target level: For a particular signal type, the input signal level for which an active (enabled) ALC device will progress to unity gain. At other input signal levels, the output level of the ALC device will be adjusted towards the target level. [Note that with some ALC devices, the target level may be different for different types of signals, e.g. the target level for speech may be different from the target level for a tone. Also, the treatment of signals which are above the target level may be different from the treatment of signals which are below the target level. In principle, an advanced ALC device may feature more than one target level, depending on the transmitted signal (e.g. speech, data, or DTMF tones).]

4 Abbreviations and acronyms

This Recommendation uses the following abbreviations:

ALC	Automatic level control
A/D	Analogue-to-digital converter
CSS	Composite source signal
D/A	Digital-to-analogue converter
DCME	Digital circuit multiplication equipment
DTMF	Dual-tone multi-frequency
ERL	Echo return loss
ISDN	Integrated services digital network

5 Characteristics of ALC devices

5.1 General

This Recommendation is applicable to Automatic Level Control (ALC) devices installed in digital network-based equipment. An ALC device is defined as any signal processing function located in the digital transmission path which automatically adjusts the level of a signal towards a predetermined value. Devices which modify the frequency response or spectral content of the signal in such a way as to affect the overall level of the signal are also defined as ALC devices for the purpose of this Recommendation.

5.2 ALC characteristics

ALC devices installed in the network should have the following characteristics:

- 1) The ability to introduce restricted gain or loss in the circuit to maintain the level of a call at a predetermined value.
- 2) The ability to maintain the stability of a connection at all times (both during call set-up and for the duration of the call), in cases with and without associated echo control.
- 3) The ability to maintain proper operation during facsimile and voiceband data transmission.

- 4) The ability to operate with realistic levels of background and circuit noise (e.g. mobile networks).
- 5) The ability to operate correctly in the presence of echo.
- 6) The ability not to interfere with the correct operation of signalling tones used in the network.
- 7) The ALC device, when disabled, should provide a 64 kbit/s bit-sequence integrity mode of operation.

5.3 Tandemed operation

There are significant issues related to the tandemed operation of ALC devices. All tandemed ALC devices should have the capability of being disabled. Methods for disabling ALC devices and the tests to ensure proper operation of tandemed ALC devices are for further study.

5.4 Delay performance

The delay in the processing path and the non-processing path of an ALC device should be kept to a minimum. For ALC devices used in networks that do not incorporate echo cancellers, the delay in the processing path should be kept to a minimum and should not exceed 1 ms. The delay in the non-processing path of the ALC device should not exceed 250 μ s for interface frame alignment. As a result, there should be no additional or incremental processing delay added in the non-processing direction of the ALC function.

For ALC devices used in networks that incorporate echo cancellers, the above constraints on the ALC processing do not apply. This is to allow flexibility in the design of algorithms that may perform functions other than simple ALC, but which are still covered by this Recommendation. In this case, the delay performance of the algorithm in the processing path should be clearly stated. The delay in the non-processing path of the ALC device should not exceed 250 μ s for interface frame alignment. As a result, there should be no additional or incremental processing delay added in the non-processing direction of the ALC function. Designers are reminded that the delay in the processing path of all such devices should be kept to a minimum.

6 Test signals

6.1 Test signal for level and gain checks

ALC devices designed to respond to speech signals may not necessarily respond to other types of signals in a similar manner. However, when making measurements of level and gain, speech is not a convenient test signal due to the natural level variations that occur. A noise signal may also be unsuitable, since the ALC device may discriminate against such a signal.

For level and gain measurements, a sine wave test signal is probably the most convenient, but care must be taken that the particular ALC device under test responds normally to the chosen sine wave frequency. For example, certain ALC devices may respond to particular frequencies by resetting the gain to unity or disabling the ALC device.

Also, some designs of ALC device do not make gain changes while a continuous signal persists. In this case it would be necessary to provide a means to on/off modulate the test signal so that gain changes can occur, but return to continuous signal mode when making the level or gain measurements. In the case of an on/off modulated test signal, references to the level of the signal within this Recommendation relate to the "on" portion of the test signal (i.e. measurements made on the unmodulated signal).

For some ALC device designs, the target level (as defined in clause 3) may be dependent on the characteristics of the applied signal, i.e. the target level with a speech signal may differ, in practice,

from the target level with a tone. For such an ALC device, this aspect does not prevent the use of a sine wave signal in the tests described in clause 7.

A suitable test signal must be selected by reference to the specifications for the ALC device under test. In most cases, suitable test signals for level and gain checks would be provided by a set of sinusoids (e.g. 204 Hz, 304 Hz, 504 Hz, 1004 Hz, 1804 Hz and 2804 Hz), on/off modulated, if necessary, at the rate 1 second on/1 second off.

In principle, an advanced ALC device may feature more than one target level depending on the transmitted signal. Such an ALC device would have the ability to discriminate between different signal types, e.g. speech, data, or DTMF tones. In this situation, for tests on the performance of the ALC device with a speech signal, care must be taken that the selected test signal is identified by the ALC device as speech.

Because tone signals may prove unsuitable or inadequate for a particular design of ALC device, consideration is given to the use of band-limited noise as the test signal. Consideration is also given to the use of the Composite Source Signal (CSS) defined in Recommendation P.501 [11]. As a last resort, pre-recorded speech may be used as the test signal, in conjunction with speech level measurement facilities such as those defined in Recommendation P.56 [1]. However, the use of speech will make certain tests difficult to perform.

6.2 Electrical circuit noise

When required in the tests, electrical circuit noise should be emulated by a continuous, gaussian, white noise signal, band-limited to the frequency range 0-3.4 kHz at source. References to the level of this noise test signal relate to the mean power of the signal, measured flat (i.e. without psophometric weighting). The level, type and time structure of this test signal is for further study.

6.3 Environmental noise

When required in the tests, environmental noise should be emulated by a gaussian, white noise signal, band-limited to the frequency range 0-800 Hz at source, and on/off modulated at the rate 1 second on/1 second off. References to the level of this noise test signal relate to the "on" portion of the signal, equivalent to the mean power of the unmodulated signal, measured flat (i.e. without psophometric weighting). The level, type and time structure of this test signal is for further study.

7 Tests

In many of the following tests, it is necessary to check the gain of the ALC device at various times to see whether any change in gain has occurred. In the test procedures, it is assumed that the ALC device has no provision that would allow its gain to be interrogated at arbitrary points in time. If a particular ALC device does include such provision, then this feature may be used to simplify aspects of the following tests, and may lead to more accurate results.

The tests relate to ALC devices installed in digital networks, therefore, the tests require the injection and measurement of signals in digital circuits. This implies the use of digital test equipment, or of suitable analogue-to-digital (A/D) and digital-to-analogue (D/A) converters.

In some cases, the ALC device under test may be integrated with, or required to work with, other network equipment such as an echo canceller. This implies a capability to inject and monitor test signals in a primary rate multiplexed bit-stream. In the case of echo cancellers, it will be necessary to ensure that these devices are fully converged before conducting any of the following tests. For this purpose, it is recommended that a white noise signal at an approximate level of -10 dBm₀ be injected into the test circuit. The noise signal should be applied first to one direction of transmission for a minimum period of 10 seconds, with no signal in the other direction; it should then be removed and applied to the other direction of transmission for at least 10 seconds.

An ALC device adjusts the level of a signal towards a target level. Typically, the target level will be user selectable within a certain range. In networks where the objectives for SLR and RLR are 8 dB and 2 dB respectively (i.e. at the mid-point of the long term objectives for these loudness ratings specified in Recommendation G.121), the desired target level with a speech signal is -19 dBm0. This level is based on the approximate relationship between SLR and speech level presented in Recommendation G.115. In some devices, the target level will be dependent on the characteristics of the input signal (e.g. the target level with a speech signal may be different from the target level with a tone). In the following test procedures, references to "target level" relate to the target level appropriate to the particular test signal in use (i.e. the level of the test signal at the input to the ALC device that would cause the device to progress to unity gain).

In the tests, it is assumed that the same target level is used in all the individual tests. The selected target level should be realistic in terms of network level objectives, bearing in mind that, for some ALC devices, the target level may be dependent on the nature of the test signal. The use of unrealistic target levels may invalidate some of the tests. Compliance tests on a device should record the target level adopted, and the type of signal to which this target level relates.

7.1 Stability

Network stability issues are addressed in Recommendation G.122 [2]. With regard to 4-wire circuits with 2-wire end paths, it is normal practice to ensure (as far as is practicable) that there is always a net loss associated with the 4-wire loop. In this way, stability is achieved even for conditions of severe impedance mismatch at the 2-wire/4-wire terminating units.

ALC devices that can introduce significant amounts of gain threaten to reduce or cancel the stability margin of a connection, particularly if ALC is installed in both directions of transmission. The problem is further exacerbated if cascaded ALC systems are permitted. The maximum gain introduced by ALC systems must be restricted to prevent instability, having regard to worst-case conditions for a connection.

ALC may be deployed in two separate network scenarios:

- a) networks without pre-existing echo control;
- b) networks with echo control.

Stability issues associated with full echo cancellation are not discussed in this clause – refer to subclause II.1.

7.1.1 Networks without pre-existing echo control

Typically, networks without echo control will be national networks where the maximum transmission delays encountered are small and do not justify the use of echo control equipment. In the short term, ALC systems will rarely be deployed in such networks since they are unlikely to have suitable signal processing platforms installed, so making the provision of ALC economically unattractive. However, the possibility of ALC systems being deployed in the future should not be neglected.

It is possible that an ALC device may include in-built echo cancellation, in which case the stability issue becomes as discussed in 7.1.2 "Networks with echo control".

If the ALC device does not incorporate echo cancellation, it is recommended that the maximum gain that the ALC system is permitted to introduce in a network without echo control is restricted to satisfy the requirements of Recommendation G.122 [2]. For some national networks, this implies that the network operator should ensure that the maximum gain introduced by an ALC device does

not exceed 0dB. This is likely to be the case where Administrations already compensate for the loss of long local lines by reducing the R and T pad losses¹.

7.1.2 Networks with echo control

International connections and the national networks of large countries usually employ echo control devices to reduce the level of reflected echo signals. In the following discussion on ALC device gain and stability, it is assumed that the ALC device is installed at a point in the transmission path after an echo control device (i.e. not within the echo path). It is further assumed that the echo control device is an echo canceller, [4] and [9].

It must not be assumed that the arguments presented below hold true if the echo control device is an echo suppressor, since these devices provide a much lower value of echo attenuation during double-talk situations. In certain conditions of send and receive levels defined in Recommendation G.164 [3], there may be no echo attenuation provided by a suppressor. Therefore, it is recommended that networks with echo suppressors should be regarded as providing no additional margin against instability. Accordingly, the recommended maximum ALC device gain is as discussed in 7.1.1 "Networks without pre-existing echo control".

An echo canceller, once fully converged, will greatly attenuate the reflected echo signal arriving at its send in port (S_{in}). Since the stability of a closed loop is dependent on the sum of the gains and losses as seen by a signal circulating in that loop, the echo attenuation provided by an echo canceller can significantly increase the stability margin of the loop. Traditionally, however, loop stability is not dependent on the echo attenuation provided by an echo canceller.

Loop stability may be considered for a connection with echo cancellation at both ends of the link, and a single ALC device installed in the echo-cancelled path in each direction of transmission. In this scenario, the maximum gain of an ALC device without causing instability could be made equal to the lowest value of echo attenuation across the telephone bandwidth achieved in practice by an echo canceller. However, due regard must be given to stability at the start of a call, before the echo canceller has converged. With this aspect in mind, it is advised that the ALC device should ideally be reset to unity gain at the start of a call. Other values of initial gain are permissible, but under no circumstances should this value exceed +4 dB. Furthermore, the ALC device gain should not increase at a rate of more than 10 dB/s. (Recognising that some ALC devices implement step gain changes, the rate of change of gain should be taken to imply the maximum total increase in gain that can be induced in the device over a one-second interval, where this interval contains the first gain adjustments occurring after a device reset.)

Taken together with the above recommendations regarding ALC device reset and rate of change of gain, it is recommended that the maximum gain of an ALC device in a connection with echo cancellation should not exceed +15 dB.

7.2 Echo

If suitable precautions are not taken, an ALC device may show an undesirable tendency to adjust its gain in response to the level of echo signals. This is particularly relevant if automatic level control is to be used on low delay circuits without echo cancellation; the gain may adjust in response to the reflected signal even though this signal is not heard as an echo.

Practical ALC device designs may include a fixed or adaptive threshold level, below which a signal will not elicit a gain response from the device. When used in a connection with echo cancellation,

¹ The R pad represents the transmission loss between the 0 dBr point at the digital-to-analogue decoder and the 2-wire side of the 2-wire/4-wire terminating unit. Similarly, the T pad represents the transmission loss between the 2-wire side of the 2-wire/4-wire terminating unit and the 0 dBr point at the analogue-to-digital coder.

such a design would probably be effective in preventing ALC gain changes in response to the level of the residual echo signal. In a connection without echo cancellation, other precautions would be necessary to prevent the ALC gain adjusting in response to echo signals.

Other ALC device designs may not be based on level thresholds. Instead, these designs may use signal processing to discriminate between speech and non-speech signals. In this way, the ALC gain would be permitted to adjust to the level of a speech signal but not, for example, to noise. If no other precautions are taken, a design of this nature may show a strong tendency to adjust in response to echo signals, particularly if used in a connection without echo cancellation.

From the above discussion, in a connection without echo cancellation, satisfactory ALC device performance in respect of echo will require a means of identifying the echo signals. This implies that an ALC device in such a connection would need to be connected to both the transmit path and the receive path.

To verify satisfactory performance of an ALC device with respect to echo signals, one of the two tests described below should be conducted. "Test A" applies to an ALC device installed in a connection without echo control. "Test B" applies where an ALC device is used in a connection with echo control, (including the case where ALC is integrated with an echo canceller).

Test A (for connections without echo control)

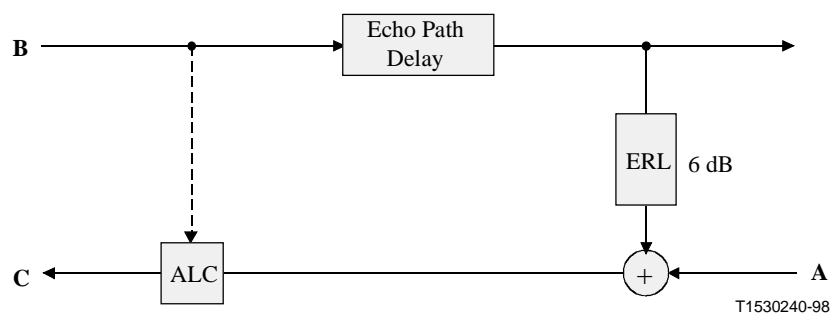

Figure 2/G.169 – Circuit configuration for "Test A" – ALC echo robustness for connections without echo control

- 1) Connect the ALC device into an emulation of part of a connection, including the anticipated worst-case echo path delay contributing to the signal arriving at the input port of the ALC device. A basic test-circuit configuration is shown in Figure 2. The echo return loss (ERL) value of 6 dB is chosen to represent worst-case echo conditions.
- 2) Apply a test signal (on/off modulated if necessary; see clause 6) to point A of Figure 2, at a level of -2 dBm₀. This level is sufficiently high to ensure that the ALC device gain is driven to (or near) its minimum value.
- 3) Measure the level of the signal at point C of Figure 2, and from this derive the value of the ALC device gain.
- 4) Remove the test signal from point A. Apply a test signal to point B of Figure 2 at the specified or pre-set target level of the ALC device under test. Note that with some ALC devices, the target level may be different for different types of signals.
- 5) The test signal at point B should be frequently interrupted (or on/off modulated at approximately 0.5 Hz). After 2 minutes, recheck the ALC device gain by measuring the level of the signal at point C. The level of the signal at the input to the ALC device may be assumed to be 6 dB below the level of the test signal at point B.

The gain of the ALC device at this stage should be within 1 dB of the value noted in step 3.

- 6) Remove the test signal from point B.
- 7) Apply a test signal (on/off modulated if necessary; see clause 6) to point A at a level 8 dB below the target level of the ALC device. This will ensure that the ALC device progresses to unity gain (or above if the ALC device is permitted to introduce gain).
- 8) Repeat step 3.
- 9) Remove the test signal from point A. Apply a test signal to point B at a level of -2 dBm0.
- 10) Repeat step 5. The measured gain should be within 1 dB of that noted in step 8.
- 11) If the ALC device gain change noted in steps 5 or 10 is more than 1 dB, the ALC device should be considered to have failed the test.

Test B (for connections with echo control)

The following test procedure should be used when it is intended that an ALC device will be used in a network with echo control (echo suppressors or echo cancellers), including the case where an ALC device is integrated with an echo canceller. The test procedure is valid whether the ALC device is installed in the send path of a connection [test circuit illustrated in Figure 3 a)] or the receive path [test circuit shown in Figure 3 b)]. However, in either case, the ALC device under test must be the only ALC device active. If it is unavoidable that other ALC devices are present in the test set-up [e.g. ALC devices integrated into the echo control device of Figures 3 a) or 3 b)], other than the ALC device under test], then these ALC devices must be disabled for the purposes of the test.

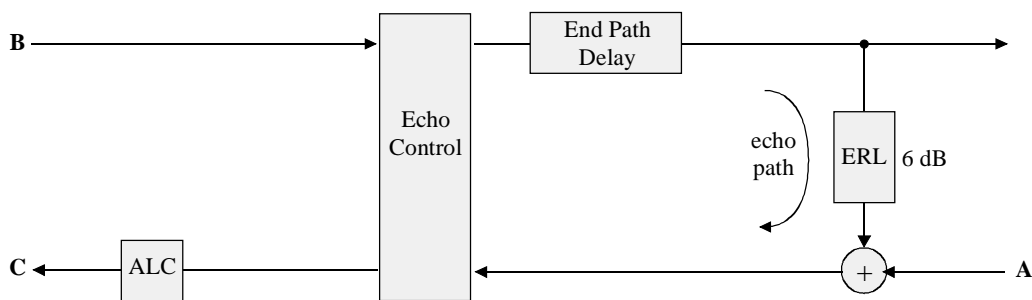

a) ALC installed in the send path of a connection with echo control

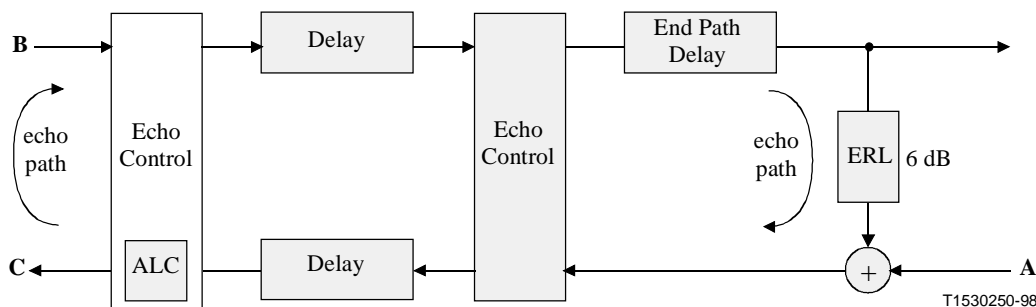

b) ALC installed in the receive path of a connection with echo control

NOTE – The ALC device may be integrated with the echo control device.

Figure 3/G.169 – Circuit configurations for "Test B" – ALC echo robustness for connections with echo control

When dealing with echo signals, it will normally be impossible to measure the gain of an ALC device integrated into the send path of an echo canceller, since access to the ALC device input is unlikely to be available. It is, in any case, difficult to measure the gain of an ALC device when the level of the echo signal at its input is drastically reduced by an echo control device. The following procedure attempts to circumvent these problems by confining observations to those of ALC device output level when passing a signal not attenuated by the echo control device.

NOTE – If the echo control device is an echo canceller, it should first be fully converged by applying a noise signal at point B (see clause 7).

- 1) Connect the ALC device into an emulation of part of a connection, including the echo path contributing to the signal arriving at the input port of the ALC device. A basic test-circuit configuration is shown in Figure 3 a) for an ALC device installed in the send path of a connection, and in Figure 3 b) for ALC installed in the receive path. The test points referred to below are marked A, B and C in these figures. The echo return loss (ERL) value of 6 dB is chosen to represent worst-case echo conditions.
- 2) Apply a test signal (on/off modulated if necessary; see clause 6) to point A of the test circuit, at a level of -2 dBm0. This level is sufficiently high to ensure that the ALC device gain is driven to (or near) its minimum value.
- 3) Establish a real-time analogue display (e.g. using an oscilloscope) of the signal at point C of the test circuit, and note the magnitude of the displayed signal. (Other means of recording the level of the signal may be used, but the chosen method must also be applicable to step 5.)
- 4) Remove the test signal from point A, and apply it to point B at the same level. The test signal at point B should be frequently interrupted (or on/off modulated at approximately 0.5 Hz).
- 5) After 1 minute, remove the test signal from point B, and re-apply it to point A. At the instant the signal arrives at point C, make an immediate note of the magnitude of the displayed signal at point C, or make a level measurement within 100 ms. (The method of level measurement should be the same as that used in step 3.) The purpose is to check whether the ALC device gain changed at all during step 4.
- 6) If the magnitude noted in step 5 exceeds that noted in step 3 by more than 12%, (or the level measurement is greater by more than 1 dB), the ALC device should be considered to have failed the test.

7.3 Noise tolerance

Automatic Level Control systems are designed to adjust speech signals towards an optimum level. During speech pauses there may be an undesirable tendency for the gain to adjust in response to the level of background noise. Therefore, tests should be made to show that the level control is robust to the worst signal-to-background noise ratio anticipated on the network.

The background noise will consist of a combination of environmental noise picked up by the handset microphone, and electrical circuit noise, the latter being particularly relevant when analogue circuits form part of the connection. These two noise sources are likely to exhibit very different characteristics. Electrical circuit noise tends to be broadband in nature, and reasonably constant in level when averaged over periods greater than a few hundred milliseconds. The nature of environmental noise obviously depends on the environment, but it may often be fluctuating in level and have spectral characteristics that are similar to speech. Indeed, the noise may often contain speech picked up from other conversations taking place near the telephone. In the mobile environment, vehicle noise is a major contributor, and noise levels can be very high.

An ALC device designed for use in telecommunication networks must incorporate measures to discriminate between the wanted signal and noise. From the previous paragraph, it is clear that environmental noise is likely to represent more of a problem to an ALC device than electrical circuit

noise. In recognition of this fact, two separate tests are presented below. "Test A" is primarily designed to check the robustness of the ALC device to electrical circuit noise. "Test B" provides some measure of assurance with respect to environmental noise. The environmental noise tests demand noise robustness for signal-to-noise ratios of 23 dB or greater. These are minimum performance requirements, and it is hoped that manufacturers can devise techniques to give a higher standard of performance.

The level, type and time structure of the noise sources for both tests A and B are for further study.

Test A (robustness to circuit noise)

- 1) Connect the ALC device (or the equipment containing the ALC device) into an appropriate test circuit, such that test signals can be applied to the input of the device, and the level of the input and output signals can be monitored. [The circuit used for the echo test (Figure 2, Figures 3 a) or 3 b) as appropriate) may be used if desired, but no signal should be connected to point B, and the ERL should be set to infinity.]
- 2) Apply a test signal (on/off modulated if necessary; see clause 6) to the input of the ALC device (or equipment containing the device), at a level of -5 dBm₀. This level is sufficiently high to ensure that the ALC device gain is driven to (or near) its minimum value.
- 3) Measure the level of the signal at the output of the ALC device, and from this derive the value of the ALC device gain.
- 4) Replace the test signal at the input of the ALC device with a continuous Gaussian, white noise signal (band limited 0-3.4 kHz) at a level of -40 dBm₀.
- 5) After at least 10 seconds, recheck the ALC device gain by measuring the level of the noise signal at the device output.
- 6) Allowing for measurement inaccuracies, the gain of the ALC device at step 5 should be within 1 dB of the value noted in step 3. If the gain has increased significantly relative to the value noted in step 3, the ALC device should be considered to have failed the test.

Test B (robustness to environmental noise)

This test is similar to Test A, but the nature of the noise signal has been changed. The adopted noise test signal reflects the fact that environmental noise may be difficult for an ALC device to reject.

The noise test signal used in the test should consist of a Gaussian, white noise signal, band limited to the frequency range 0-800 Hz, and continuously on/off modulated at the rate 1 second on/1 second off. References to the level of the noise test signal relate to the level of the "on" portion of the signal, equivalent to the mean power of the unmodulated signal.

- 1) Connect the ALC device (or the equipment containing the ALC device) into an appropriate test circuit, such that test signals can be applied to the input of the device, and the level of the input and output signals can be monitored. [The circuit used for the echo test (Figure 2, Figures 3 a) or 3 b) as appropriate) may be used if desired, but no signal should be connected to point B, and the ERL should be set to infinity.]
- 2) Apply a test signal (on/off modulated if necessary; see clause 6) to the input of the ALC device (or equipment containing the device), at a level of -5 dBm₀. This level is sufficiently high to ensure that the ALC device gain is driven to (or near) its minimum value.
- 3) Measure the level of the signal at the output of the ALC device, and from this derive the value of the ALC device gain.
- 4) Replace the test signal at the input of the ALC device with a noise test signal, as defined above, at a level (when unmodulated) of -28 dBm₀.
- 5) After at least 20 seconds, recheck the ALC device gain by measuring the level (when unmodulated) of the noise test signal at the device output.

- 6) Allowing for measurement inaccuracies, the gain of the ALC device at step 5 should be within 1 dB of the value noted in step 3. If the gain has increased significantly relative to the value noted in step 3, the ALC device should be considered to have failed the test.

7.4 Signalling tones

An ALC system must not interfere with the correct operation of signalling tones used in the network. In the case of tones used to setup a connection, the level control could, for example, be disabled (held at unity gain) until the link is established. For DTMF signals, it will be necessary to test that the level control does not affect the reliability of their detection.

7.4.1 DTMF tests

A typical ALC device is unlikely to differentiate between speech signals and DTMF signals; therefore, it is possible that gain adjustments will occur during the transmission of DTMF signalling. The accuracy of DTMF detection may depend not only on the ALC device, but also on the particular DTMF detector.

Method 1

It is assumed that an ALC device operates on DTMF tones, where $-23 \text{ dBm0} \leq \text{target level} \leq -5 \text{ dBm0}$. With this stipulation, DTMF detectors, in general, may be tolerant to the gain changes introduced by an ALC device, provided that the rate of change of gain during transmission of a tone is sufficiently slow. A suitable test for maximum rate of change of gain is outlined below, and the test circuit is shown in Figure 4.

NOTE 1 – The test described uses hardware detection and measuring equipment applied to the analogue signal. However, an equivalent software test applied to the digital signal is equally valid.

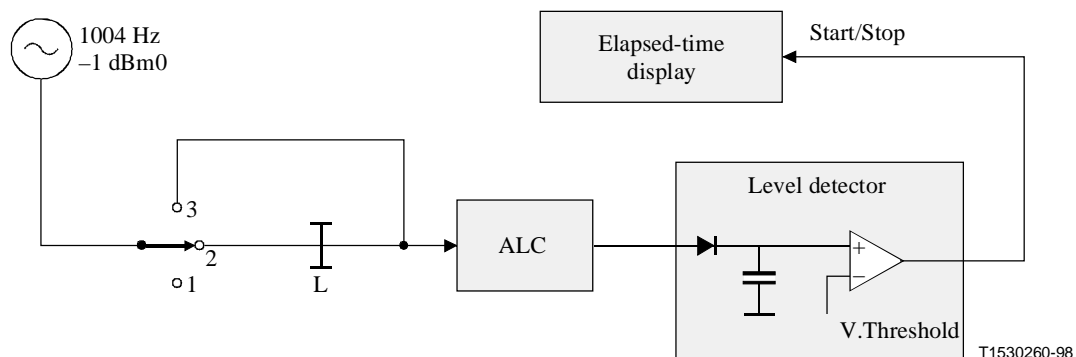

NOTE – i) Attenuator $L = -[1 + \text{target level (dBm0)}] \text{ dB}$.

ii) $V.Threshold$ set so that elapsed-time counter stops when the output level from the ALC device falls to -4 dBm0 .

Figure 4/G.169 – Circuit configuration for measuring rate of change of ALC device gain

NOTE 2 – Certain ALC devices operate by making instantaneous large step changes in gain, and other devices can introduce step decreases in gain during overload conditions. The following test is not valid in these situations. However, if step gain changes are only permitted during pauses in the transmitted signal, or at the very start of a signal burst, it may be assumed that this type of gain behaviour will not affect the accuracy of DTMF detection.

- 1) Connect external threshold-level detection logic to the output of the ALC device. This logic should be configured to control the start and stop of an elapsed-time counter. For an increasing signal level at the output of the ALC device, the timer should start when the level is somewhere between -4 dBm0 and -2 dBm0 . For a decreasing signal level, the timer should stop when the level reaches precisely -4 dBm0 .

- 2) Apply a 1004 Hz test tone to the input of the ALC device at the specified or pre-set target level. Note that with some ALC devices, the target level may be different for different types of signals. Allow time for the ALC device gain to settle to unity. (For certain ALC devices, it may be necessary to disconnect and reconnect the test tone a few times to ensure that the gain settles to unity).
- 3) Confirm that the ALC device is at unity gain by monitoring input and output levels to the device.
- 4) Instantaneously increase the level of the input signal to the ALC device to -1 dBm₀, which should automatically trigger the start of the elapsed-time counter.
- 5) The elapsed-time counter should stop automatically when the output signal level from the ALC device has fallen from -1 dBm₀ to -4 dBm₀, i.e. the ALC device gain has fallen by 3 dB. From this, the rate of change of gain may be derived, and expressed in dB/s. The derived value will approximate to the maximum rate of change of gain for the ALC device.
- 6) The ALC device should be considered to have passed the test if the derived rate of change of gain is less than 10 dB/s.

Method 2

The following test procedure should be followed if test method 1 is inappropriate for a particular ALC device, or if the device fails test method 1, or the results are inconclusive.

In any test to check DTMF detection accuracy in a connection with an ALC device, the choice of DTMF detector may influence the percentage of detection failures. To circumvent this problem, the following test is based on a comparison of DTMF detection performance with and without the ALC device in-circuit. It is therefore unnecessary to specify a standard DTMF detector for the test.

The test requires a means of inputting a sequence of DTMF characters to the test circuit (e.g. sequence stored on digital audio tape, or PC file). A suitable DTMF detector (which may be PC based for convenience) is also required, together with a means of recording the percentage of character detection failures in the replayed DTMF test sequence. A noise source is needed for the second phase of the tests, and the basic test configuration is shown in Figure 5.

The DTMF test sequence should consist of 256 different DTMF signals, arranged as 16 sets of the 16 DTMF characters (0..9,#,*,A,B,C,D). Each set has the frequency offset specified in Table 1. The replayed levels of the discrete frequencies making up the tone pairs should be as specified in Table 1. Each DTMF character should have a duration of 50 ms, with an interval between characters of 100 ms. The interval between each set should be 1 second, and the 16 sets of DTMF characters should be replayed as a continuous sequence of 256 characters.

Table 1/G.169 – DTMF test sequences

Set No.	Freq. offset (%) (low freq.)	Freq. offset (%) (high freq.)	Level (dBm0) (low freq.)	Level (dBm0) (high freq.)
1	0	0	0	0
2	0	0	-18	-18
3	1.5	1.5	-10	-10
4	-1.5	-1.5	-10	-10
5	0	0	-12	-18
6	0	0	-14	-10
7	1.5	1.5	-14	-20
8	-1.5	1.5	-14	-20
9	1.5	-1.5	-6	-12
10	-1.5	-1.5	-6	-12
11	0	0	-12	-18
12	0	0	-14	-10
13	1.5	1.5	-10	-6
14	-1.5	1.5	-10	-6
15	1.5	-1.5	-18	-14
16	-1.5	-1.5	-18	-14

Annex A/Q.24 [12] indicates that some Administrations require DTMF receivers to tolerate power levels per frequency up to 0 dBm.

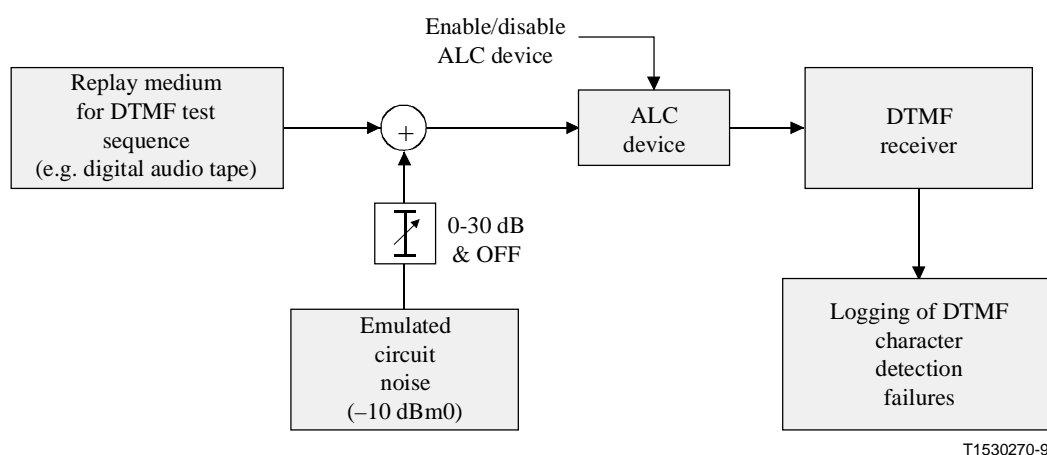

T1530270-98

Figure 5/G.169 – Circuit configuration to check effect of ALC device on DTMF detection performance

- 1) With the ALC device disabled, replay the DTMF test sequence over the test circuit. Record the percentage of detection failures and detection errors.
- 2) Repeat step 1 a sufficient number of times to satisfactorily establish the standard of DTMF detection performance.

- 3) Repeat steps 1 and 2, but with the ALC device enabled. If DTMF detection performance is noticeably worse with the ALC device enabled, it must be assumed that the ALC device degrades the transmission of DTMF signals.
- 4) If the preceding steps do not show a noticeable difference in DTMF detection accuracy between the two conditions, proceed as follows.
- 5) Arrange for emulated circuit noise to be injected into the test circuit at the input to the ALC device.
- 6) Starting with a suitable level of circuit noise (e.g. -40 dBm0), repeat step 1 a number of times, increasing the level of circuit noise at the end of each run until the percentage of DTMF detection failures reaches approximately 5%.
- 7) Maintain the level of injected circuit noise at the value reached in step 6. Repeat steps 1 to 3.
- 8) If the preceding steps indicate that the ALC device does not cause a problem for DTMF transmission, as final confirmation of this conclusion, repeat all of the above with the DTMF test sequence attenuated by 6 dB at the input to the ALC device.

7.5 Voiceband data and facsimile transmission

An ALC system designed to enhance speech transmission must not degrade other telecommunications services such as voiceband data and fax. An ALC device should therefore be designed to automatically disable upon detection of the 2100 Hz tone (with or without associated phase reversals or amplitude modulation) that precedes V-series modem communications. A suitable disabler is described in 7.5.1. For ALC devices operating in the forward direction of a voice-band data or fax transmission, recognition of 2100 Hz tone implies that the device be connected to both the go and return paths. The tone disabler of an ALC device should therefore be designed to operate on tones that are present in either direction of transmission.

For the purpose of disabling ALC devices, consideration may also be given to more sophisticated methods of detecting voiceband data or facsimile transmissions. However, if implemented, such methods should be considered as additional to the basic requirements of the tone disabler specified in 7.5.1.

A disabled device should provide bit-sequence integrity for the full duration of the voiceband data or fax call. In the case of the latter, it is important that the ALC device should remain disabled throughout the transmission of a multi-page document, i.e. there should be no tendency for the ALC device to re-enable during page breaks or other pauses in the fax transmission.

In recognition of the fact that a small proportion of voiceband data and fax calls may not be preceded by 2100 Hz answer tone, it is additionally recommended that an enabled ALC device should not degrade these transmissions under normal network conditions; extremes of signal level and circuit noise may be excluded from the verification tests, provided the requirements for 2100 Hz disabling have been fully met.

7.5.1 Disabler characteristics

This subclause deals with the specification of an ALC device disabler that is activated on reception of 2100 Hz answer tone. The objectives for a disabler are that the ALC device should be disabled throughout the full duration of fax and data transmissions.

The requirements for an ALC device tone disabler are the same, in many respects, as the requirements for echo suppressor and echo canceller tone disablers. The principal differences between echo suppressor and echo canceller tone disablers are briefly reviewed in the next paragraph.

The required characteristics for an echo suppressor tone disabler are presented in Recommendation G.164 [3]. The required characteristics for an echo canceller tone disabler are presented in Recommendation G.165 [4] and also in Recommendation G.168 [9]. To disable an echo canceller, the G.165/G.168 tone disabler must detect a 2100 Hz tone with periodic phase reversals (as specified in Recommendation V.25 [6]). The G.164 tone disabler will implement disabling on detection of a 2100 Hz tone, with or without phase reversals. In other respects, the required characteristics of the two types of echo control device tone disabler are very similar. The G.165/G.168 disabler has an additional requirement that it should not operate falsely on data signals; (this requirement is inappropriate for an ALC device tone disabler). Also, compared with the G.164 disabler, the need to detect phase reversals of the 2100 Hz tone has led to an increase in the maximum time allowed for the G.165/G.168 disabler to operate in response to the disabling tone.

Once activated, the conditions for release from the disable state are the same for both the G.164 and G.165/G.168 specifications. Release is based on the signal level in both directions of transmission falling below a threshold level for more than a specified time period (the 'release time'). The specified release time is 250 ± 150 ms; the lower limit is chosen to prevent unwanted release for short signal drop-outs, and the upper limit is to minimise the impairment if the disabler is accidentally activated by speech.

An ALC device tone disabler is required to disable the device for all fax and data calls. The tone disabler must therefore respond to 2100 Hz tone, with or without phase reversals. The G.164 tone disabler is suitable in this respect, whereas the G.165/G.168 disabler is not. An ALC device tone disabler should also respond to 2100 Hz tone with amplitude modulation (as defined in Recommendation V.8 [5]).

An important requirement for an ALC device disabler is that it should keep the device disabled throughout the full duration of fax and data transmissions. The release time specified for the echo control disablers is insufficient to achieve this, since there would be a strong tendency for the ALC device to become re-enabled during pauses in a fax transmission (e.g. page breaks). To satisfy the requirement to maintain the disabled state throughout a fax transmission, the minimum release time for an ALC device tone disabler is recommended to be 3450 ms². However, a long release time is undesirable in the event that the disabler is accidentally activated by speech, therefore the release time should not be permitted to greatly exceed the minimum value. The recommended maximum release time is 3500 ms.

Concerning the possibility of an ALC device disabler being accidentally activated by speech, it is more important to ensure that this is a rare event than it is to re-enable the device quickly if such an unwanted event occurs. This is because the initial unwanted gain reset will be the primary cause of subjective impairment due to the probable step gain change that occurs, whereas the persistence of the disabled state is merely the continuance of the unity gain state. When the ALC device eventually re-enables, a gradual progression will ensue back to a gain value more suited to the actual speech level. With this in mind, designers of tone disablers for ALC devices may wish to maximise the 'operate time' for the disabler, since a longer operate time gives improved immunity to false operation by speech. However, as the disabler is required to activate for all fax and data calls, the operate time must be less than the minimum anticipated duration of answer tone. The duration of answer tone in various scenarios is specified in Recommendation V.25 [6], and examination of V.25 indicates that an appropriate maximum value for the operate time of an ALC device tone disabler would be 400 ms, as adopted for the G.164 tone disabler. It is therefore recommended that ALC device tone disablers adopt the operate time specification of the G.164 tone disabler, i.e. 300 ± 100 ms.

² Recommendation T.30 [7] shows that silence periods of $3 \text{ s} \pm 15\%$ are permitted following establishment of a fax call, and the same interval is permitted following a 'repeat' request. In practice, there are various situations that may result in a long pause.

In summary, an ALC device tone disabler should have the characteristics of either a G.164 or a G.165/G.168 tone disabler, modified where necessary to ensure the following:

- Disabling should occur in response to 2100 Hz tone, with or without phase reversals (as specified in Recommendation V.25 [6]), and with or without amplitude modulation (as defined in Recommendation V.8 [5]).
- Operate time = 200 ms minimum
400 ms maximum
- Release time = 3450 ms minimum
3500 ms maximum

NOTE – The release time specified above is necessary, only if the tone disabler re-enables the ALC device solely on detecting the absence of signal energy. If the tone disabler re-enables based on other criteria, then the release time specified above does not apply. Tests for proper operation are for further study.

7.5.2 Tests to confirm satisfactory voiceband data and fax performance when an ALC device is not disabled by 2100 Hz

The following tests are considered necessary, since a small percentage of fax or voiceband data calls may not be preceded by 2100 Hz answer tone, and therefore, the ALC device may remain enabled during these calls. The tests are based on a direct comparison of performance with and without the ALC device enabled.

Separate tests should be conducted for voiceband data and facsimile transmissions, although the basic test procedure is the same in both cases. To facilitate the tests, it is recommended that specialised, proprietary voiceband data or fax test equipment is used, but other arrangements capable of making the required observations are acceptable.

For voiceband data tests, the test equipment should be configured to operate in automatic answer mode, conforming to the requirements of Recommendation V.25 [6].

For facsimile tests, the test equipment should be configured to follow the procedures defined in Recommendation T.30 [7], and with the following T.30 options selected:

- automatic operation at both the calling and the called stations;
- calling station transmits to called station, (operating method 4-T in Recommendation T.30);
- binary coded signalling at 300 bit/s to be used (rather than tonal signalling);
- the standard time-outs for binary coded signalling should apply;
- the optional error correction mode defined in Annex A/T.4 [8] (and the associated procedures described in Annex A/T.30) should not be used.

For designers of fully-automated G.169 test equipment, it is recognised that adherence to all aspects of T.30 call control may be unnecessarily restrictive. For such designs, the requirement to follow T.30 procedures may be relaxed, but the principle of comparing fax transmission performance with and without the ALC device must remain the basis of the test.

The ALC device must be tested under conditions that reflect the type of connection in which it is to be used. The test circuit should emulate the principle features of a connection, including delays appropriate to the type of connection (e.g. international, via satellite). The echo return loss (ERL) should be 6 dB or better, for both directions of transmission. The ALC device should be installed at the intended point within the emulated connection, and should be located in the calling station to called station direction. For fax, this should represent the direction of facsimile transmission adopted for the tests. For voiceband data, this represents the direction in which error rate performance should be monitored.

In the following test procedures, references to transmit level relate to the level in the calling station to called station direction. The transmit level should be set up by an appropriate combination of the

level from the test equipment, and the losses in the emulated connection; both these controlling factors may be varied within realistic operational limits to achieve the specified transmit level. The level in the opposite direction of transmission is not specified, but should be that which results naturally from the emulated connection (configured to achieve the specified transmit level), and an operationally realistic level from the test equipment representing the called station. An additional constraint on the emulation is that the receive level at both the calling and called stations should be high enough to allow reliable operation of the fax or voiceband data test equipment. (Typically, a minimum receive level of -40 dBm would be adequate.)

Test procedure

As the ALC device will disable in response to 2100 Hz answer tone, for comparison purposes, a method must be found to prevent this happening for some of the fax and voiceband data transmissions. The ALC device may include a facility to force it to ignore 2100 Hz answer tone; if not, it will be necessary to eliminate 2100 Hz answer tone from the test transmissions, and set the ALC device to the required enabled or disabled state prior to each transmission. If there are echo cancellers in the test circuit, it will also be necessary to ensure that these are in the desired state for the test transmissions. (Note that if it is necessary to eliminate answer tone, this represents a modification to the V.25 or T.30 requirements for an automatic answer configuration.)

- 1) Connect proprietary voiceband data, or fax test equipment (as appropriate) to the test circuit. Since high-speed communications are more sensitive to impairments than low-speed communications, the test equipment should be configured to attempt to communicate at the highest data rate in common use in the network.
- 2) Make appropriate arrangements to ensure that the ALC device will be disabled (set to fixed unity gain) during a fax or data transmission. (If the ALC device does not have a disable facility, it may be necessary to temporarily replace it with a direct connection.)
- 3) At a chosen transmit level, make a fax or data transmission over the connection using a reference data file. In the case of voice-band data transmissions, it should be arranged that the data transfer takes at least 20 seconds at the selected communication rate. For fax transmission, the transferred data should comprise at least a 3-page fax, since page breaks may influence the operation of the ALC device.
- 4) Observe whether any fall-back in transmitted data rate occurred relative to the selected maximum rate, and whether any other disruption occurred to the normal sequence of events to establish communications.
- 5) Note the result of an appropriate measure or indication of the received data errors.
- 6) Make appropriate arrangements to ensure that the ALC device will not be disabled by 2100 Hz answer tone at the start of a fax or voiceband data transmission.
- 7) Repeat steps 3, 4 and 5, noting any significant differences in performance or behaviour relative to that obtained previously.
- 8) Repeat steps 2 to 7 a number of times, for different transmit levels in step 3. The transmit level should be varied over the range -8 dBm⁰ to -22 dBm⁰³.
- 9) If, at any of the transmit levels tested, the performance with the ALC device enabled is appreciably worse than with the device disabled, the ALC device should be considered to have failed the test. In particular, any fall-back in transmitted data rate caused by the ALC device is unacceptable.

³ Measurements show that about 8% of UK international receive fax levels lie outside this range. Assuming that up to 5% of fax calls are not preceded by a suitable ALC device disabling tone, this test will ensure that at least 99.6% of fax calls are not degraded by the ALC device.

ANNEX A

Guidance for measuring signal levels in networks

Level measurements are necessary to check whether signal levels in a network are within an acceptable range. A large number of calls must be measured in order to obtain a statistically valid distribution of call levels. The distribution will show whether call levels are perhaps generally too high, too low, or have an unacceptably wide spread.

Speech signal levels are best measured with an instrument conforming to Recommendation P.56 [1], which specifies a method of measuring the rms level of a signal during periods when that signal is active. The restriction to active signal periods is particularly important for speech signals because there are silence intervals in the speech waveform that act to reduce the long term level. The P.56 algorithm defines how to determine the level at which the speech signal is considered to be active (since this will vary with different talker levels and background noise) and calculates the rms value over the active periods only. Although an instrument conforming to Recommendation P.56 is primarily aimed at the measurement of speech signal levels, it may also be used to measure the level of facsimile and voiceband data signals, signalling tones, etc.

Some Administrations use automatic equipment (see Recommendation P.561 [10]) to make routine level measurements on their networks. Typically, such level measurements will either conform to the P.56 method, or adopt similar active signal measurement principles. The use of proprietary, automatic equipment greatly reduces the labour needed to make a large number of measurements. However, in many situations – trouble-shooting, in particular – manual level measurements are still appropriate, due to their flexibility, ease of deployment and low equipment costs. The following paragraphs concentrate on a simple, manual measurement technique, since the procedures for the installation and use of proprietary, automatic equipment will be well-defined in the manufacturer's literature.

Many P.56 measuring instruments have analogue front-ends, and are therefore only capable of measuring signals that are in analogue format. Conversely, when performing signal level measurements within a network, it is best to extract the signal at a digital point (probably at the 2.048 Mbit/s or 1.544 Mbit/s multiplex level) since the relative level of a digital point within the network is clearly defined. Consequently, it is necessary to use proprietary equipment to extract the appropriate channel from a 2.048 Mbit/s or 1.544 Mbit/s stream, and convert the transmit and receive signals to analogue. The analogue signals may then be presented to the P.56 measuring device.

An example of how to measure speech signal levels within a network is given in Figure A.1. In this example, a proprietary signal monitor is connected to the transmit and receive points of a 2 Mbit/s digital monitor frame. The appropriate channel is selected, and the transmit and receive signals are converted to analogue by the monitoring equipment. The input impedance of the P.56 instruments is set to 600 ohms to ensure that the gain of the monitoring equipment is as specified by the equipment manufacturer. Typically, the gain of the monitoring equipment will be 0 dB; therefore, the relative level of the analogue measurement point will be equal to the relative level of the digital monitor point. The P.56 instruments should be set to measure active level in dBm (600 ohms).

NOTE 1 – In international networks, the signals are monitored on the international side of the echo canceller. This is so that echo signals do not influence the measurements taken. If no echo canceller is present, then care must be taken when interpreting the results.

When taking measurements, the particular call should be monitored via headphones at the start to determine whether the call is speech or data. The measurement is then started by activating the P.56 instrument, and after a suitable measurement period (suggest not less than 20 seconds) the measurement is stopped and the reading is noted.

NOTE 2 – If the P.56 device is controllable via a GPIB bus, the measurement process can be semi-automated if a separate PC is used as a controller. It is also possible that the P.56 device, itself, is PC based, and may feature more than one measurement channel. Using such equipment, the measurement results can be logged automatically, but speech/data discrimination still has to take place. To preserve the simplicity of the measurement configuration, this latter aspect is probably best achieved by headphone monitoring, as before.

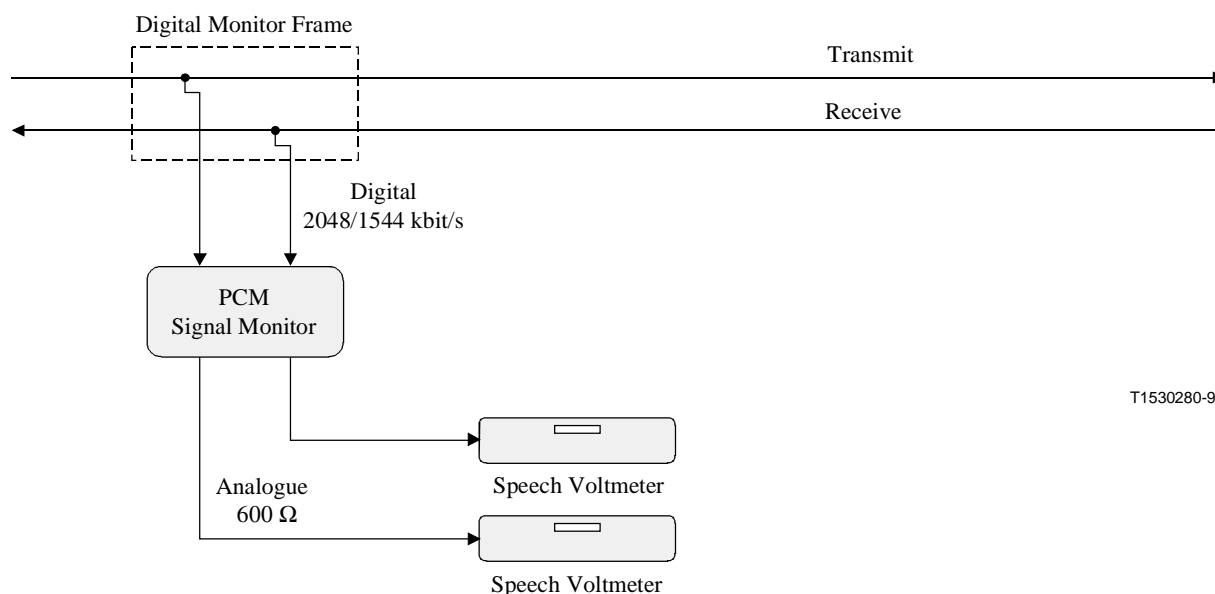

Figure A.1/G.169 – Taking speech level measurements on a digital network

APPENDIX I

Guidance for the design of Automatic Level Control (ALC) algorithms and their placement in the PSTN

I.1 Introduction

The control of speech levels in the telephone network is important for the listeners' comfort, and to ensure optimum performance of network equipment. Manufacturers of network signal processing equipment (e.g. echo cancellers) are developing Automatic Level Control (ALC) algorithms as an option for network operators. This appendix discusses some of the issues relating to the design and operation of ALC algorithms and provides useful guidance for the designers of such algorithms and for network planners who are considering the introduction of ALC algorithms into the PSTN.

I.2 Discussion

There are two basic reasons why the control of speech levels is important for telephony. The first is simply that people prefer speech to be at a comfortable level at which they are best able to understand it. Obviously, this 'preferred level' will vary from person to person, and will also be dependent to a certain extent on the level of background noise. Despite this, it is possible to select a listening level that is comfortable to the majority of people with normal hearing.

The second reason why speech levels are important is one of equipment performance. Each active device, such as an amplifier or speech codec, will have a certain dynamic range over which it will function to specification; outside this range the performance may degrade rapidly, leading to noise and distortion of various types. For this reason, it is important to maintain speech levels within the dynamic range specified for the equipment.

Traditionally, the strategy of the telecommunications providers has been to provide tight specifications for equipment and networks such that, for the large majority of calls, signal levels will lie within an acceptable range. Digitalisation of the networks has assisted in this objective. However, customer expectations have increased, and other factors such as deregulation and competition have contributed to the difficulty of maintaining adequate control of levels. In recent times, international communications have increased dramatically, and the network operator has no direct control over the distant networks. The network operator must cope with increasing amounts of hands-free mobile telephony, and coupled with all these factors, there will always be a small percentage of very loud or very quiet talkers.

In principle, the preferred listening level could be set by a volume control on the telephone instrument but, for historical reasons, few telephones are fitted with volume controls, even today. In any event, this would address only the listening level aspect, and would do nothing to ensure that network equipment is presented with the correct level. To assist in this latter respect, the level would need to be adjusted at an early point in the network. This suggests that some form of automatic level control (ALC) device should be installed at an appropriate point in the network, which would continuously monitor the transmitted level and adjust the gain accordingly. In other areas such techniques are far from new, used for example in the r.f. stages of radio receivers, and to control the microphone level in tape recorders. However, these processes have their limitations and drawbacks: a sound recording engineer will often reject ALC in favour of tried and trusted manual control! For the telephone network, the range of signals and services to be handled are wide, and it will be necessary to ensure that an ALC system does not sometimes degrade the performance for particular signals rather than enhance them.

I.3 ALC considerations

Before new technology is introduced into the network, the telecommunications operator must ensure that it does not have an adverse effect on any aspect of the existing service. In this subclause, the siting of ALC is considered and a number of performance issues, objective and subjective, are raised.

I.3.1 Location of ALC

If ALC is to be introduced, it should be installed at an early point in the transmission path so that all the subsequent network equipment can benefit from the level optimization. To derive maximum benefit, the ALC would need to be located at the earliest 4-wire point in the transmit path, so that level variation due to talker loudness, mouth-to-handset distance, telephone instrument variations, and local line loss are accommodated, and the ALC precedes all the active equipment in the 4-wire path. Ideally, the ALC would precede even the conversion to 64 kbit/s digital format, since it could then be designed to prevent peak-clipping of high level signals, and to minimise the deterioration in signal to quantization noise ratio resulting from the level adjustment. However, with regard to a rapid, large-scale upgrade, the cost implications of installing ALC at this location are likely to be prohibitive. Elsewhere in the national network, the provision of ALC alone is unlikely to be economically viable unless demands for advanced services and facilities lead to the widespread introduction of a general-purpose signal processing capability.

The economics of providing ALC specifically for international circuits are more attractive, especially if use is made of existing signal processing equipment (e.g. echo cancellers) as a platform on which to implement ALC. The ALC equipment would be located in the transmit path at the international exchange; therefore, all active equipment in the international transmission path would benefit from the level control, but any in the preceding national part of the connection would not.

I.3.2 Algorithmic and subjective considerations

With ALC installed after the conversion to 64 kbit/s digital format, as in the case of ALC at the international exchange, any clipping on a high level speech signal would remain even after the signal is attenuated by the ALC. This clipping distortion may even become subjectively more noticeable at the lower listening level. Also, any level adjustment will degrade the signal to quantization noise ratio to some extent, and this may tend to negate the subjective enhancement resulting from the level optimization.

In the particular case of very low level speech signals for which the signal to quantization noise ratio is already reduced relative to a normal level signal due to the characteristics of A-law or μ -law PCM, the quantization noise may become subjectively more disturbing after the signal is amplified by the ALC. This situation is similar to the case of a quiet talker in a high background noise environment such as a noisy office, or noisy vehicle in the case of a mobile telephone. Amplification of the speech may make the background noise more objectionable.

Considering another aspect of the high background noise situation, it is crucial that the ALC should not interpret this noise as speech and amplify the noise to the normal listening level for speech. Such behaviour would clearly be disastrous for the call, causing massive gain oscillations triggered separately by the speech and speech pauses. However, the very high noise levels that can occur in the mobile environment, the spectral characteristics and variability of this noise, make foolproof ALC operation difficult to guarantee.

Another subjective question concerns the effect ALC has on the speech dynamics and the consequent effect on a conversation. For example, a person may convey anger, excitement, regret, etc. by appropriately raising or lowering the voice, but this level change could be totally cancelled out by the ALC. The ALC gain characteristic and the choice of time constant within the ALC must, therefore, be selected very carefully in order to minimise the subjective impact of this unwanted effect. If the time constant is too short, it could lead to the loss of emphasis on words and phrases, and could also result in a pulsing effect on the speech level due to the gain adjustment becoming out-of-step with the speech energy. A long time constant is therefore preferred, but this will extend the time to adapt to a change in level due, for example, to a change of talker, changing from a handset to a loudspeaking telephone, or the start of a new call.

The time taken to adjust the gain at the start of a new call is particularly important, and the ALC algorithm must be proved satisfactory in this respect. If the previous call was very quiet, the ALC will have adapted to introduce perhaps its maximum gain. If the new call is, in contrast, very loud, the combination of high level and high gain will give the listener an unpleasant acoustic shock. The painfully high signal level will persist until the ALC has made the appropriate adjustment to the gain. If, on the other hand, a low level call follows a high level one, the combination of low level and high attenuation could render the first few seconds of speech virtually inaudible. The listener might even assume the call had failed, and hang up.

The large gain error that could exist at the start of a new call suggests that some form of rapid or step gain adjustment should come into play when the need for this is detected. The detection strategy would require careful design to prevent unwanted step gain changes during normal conversation, since such effects would be highly objectionable. However, the requirements for a rapid but very reliable decision are in conflict. It would, for example, be particularly difficult to quickly detect the need for a step increase in gain since the decision must be based upon the detection of a low speech level, and this implies measurement over an appreciable time interval. A quick decision would be highly unreliable.

On subjective issues, there is one final sacrifice the users must be prepared to accept if they are to benefit from the introduction of ALC. For a listener in a noisy environment, or perhaps slightly hard of hearing, there would be little or no benefit in asking the talker to speak up, since the ALC would quickly compensate if the speaker obliged!

I.3.3 Equipment issues

It has already been mentioned that a low level, poor signal-to-noise ratio speech signal may be subjectively less acceptable after amplification by the ALC. Such a signal, once amplified, may also be problematic for digital circuit multiplication equipment (DCME). One of the processes of DCME is digital speech interpolation (DSI), and therefore a voice activity detector (VAD) is required to detect the presence of speech on the incoming trunks. If the VAD uses simple level thresholds (as for the VAD example given in Recommendation G.763 for DCME), the amplified, poor signal-to-noise ratio signal may be misinterpreted as continuous speech activity, and so affect the achievable channel multiplication of the DCME. Thus, although the performance of network equipment would often be enhanced by the use of ALC, there are specific situations where it may be detrimental.

The preceding text has concentrated on issues concerning the operation of ALC with speech signals. However, a significant proportion of traffic is attributable to voiceband data and facsimile calls. The nature of these signals varies depending on the particular modulation scheme, and signals may be continuous or interrupted as in the case of the acknowledgement signal in the return direction of a facsimile call. The optimum mean level for such signals may be different to that for speech. In addition, the network must faithfully transport signalling tones. The ALC algorithm and its time constants must be shown not to disturb or degrade any of these transmissions. Alternatively, the means must be provided to automatically disable the ALC when these signals are being transmitted.

I.3.4 Echo

Since the ALC is installed in the 4-wire loop, unwanted echo signals will be present, primarily due to reflections at the 2-to-4-wire interface. The consequence of the ALC adjusting its gain for the echo signal would have a devastating effect on the call. Steps must therefore be taken to prevent the ALC adjusting to echo signals. In the international network, the ALC could be installed in the transmit path after the echo canceller, so reducing the likelihood of the ALC adjusting to any residual echo signal. If ALC is installed before the echo canceller (or in a link without echo cancellers), robustness to echo will require additional complexity in the ALC algorithm, and a need to monitor the level of the receive path signal as well as the transmit path. In the case of ALC in the tail path of an echo canceller, the performance of the canceller will be impaired unless its adaptation speed is at least as fast as that of the ALC. Perhaps the most elegant and cost effective solution to the provision of ALC without susceptibility to echo is to design the ALC as an integral part of the echo canceller. Adaptation speed considerations could be accommodated, and the ability to monitor both directions of transmission would be intrinsic.

I.3.5 Loop stability

Regardless of whether the ALC is installed in the national or international network, it will be located within the 4-wire transmission loop. This means that the maximum gain the ALC can introduce must be limited in order to preserve loop stability. It will be necessary to confirm that loop stability is guaranteed even with the maximum ALC gain and the worst case loop conditions.

The loop stability issue raises an important question regarding the possibility of encountering cascaded ALC systems. If two cascaded ALC systems each put in their maximum gain, the loop stability criterion may be breached. Either network planners must ensure cascaded ALC systems are never encountered, or a facility must be provided to automatically disable all but the first ALC system in the link.

It must not be overlooked that ALC could often be installed in both directions of transmission. Where there are transmit and receive ALC systems at the same end of the transmission link (e.g. within an echo canceller), it might be advantageous to restrict the receive ALC to an attenuation function, so that it cannot introduce gain. This would allow the transmit ALC to insert the maximum gain consistent with loop stability. However, this maximum gain value must be halved if there is a possibility that an ALC device will exist in the transmit path at the opposite end of the transmission

link (i.e. a balanced ALC system, offering equal benefits to the two transmission directions). The essential consideration is the total gain introduced into the 4-wire loop.

APPENDIX II

Considerations relating to ALC deployment

II.1 Location of ALC

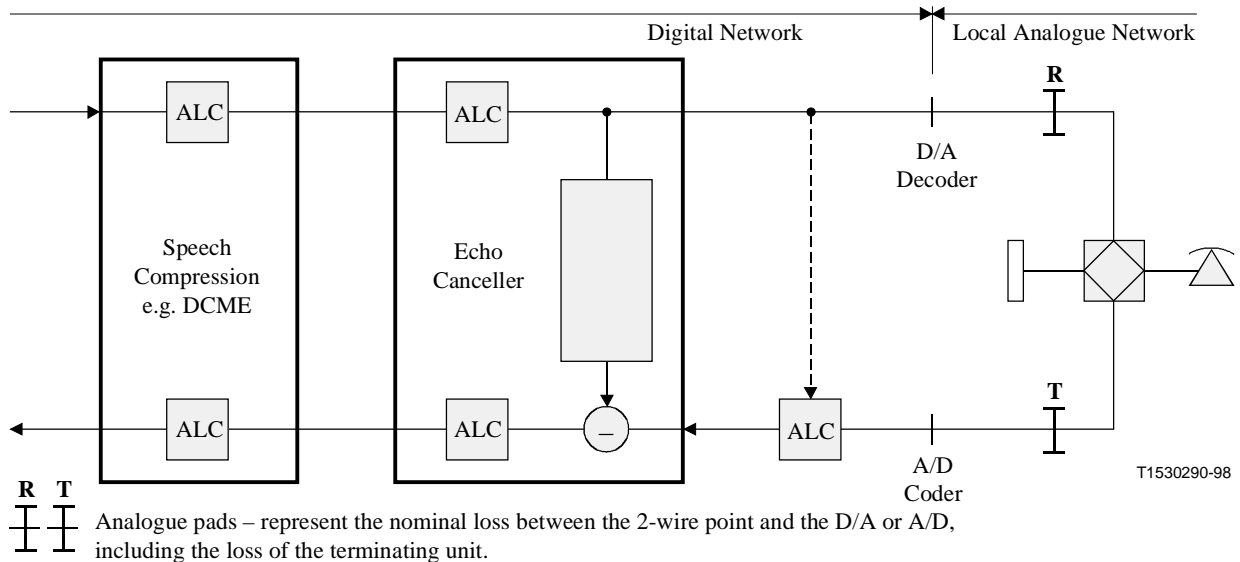

Figure II.1/G.169 – Simplified diagram of transmission network showing possible locations of ALC devices

Figure II.1 illustrates typical locations where ALC devices may be installed in a network. The diagram represents one end of a connection, and ALC devices may be installed in equivalent locations at the other end of the link. It is not intended to imply that it is desirable to have ALC devices at all of these locations. Indeed, the use of multiple ALC devices may cause stability problems (see 7.1), and ALC devices in cascade may lead to performance penalties for the level control function.

In the case of the latter, these penalties arise because the rate of change of gain perceived by the listener will be increased if cascaded ALC devices are encountered, and gain overshoot effects may also occur. Also, if the first ALC device encountered introduces gain, the amplified circuit noise and background noise may then adversely affect the operation of subsequent ALC devices in the connection. Thus if an ALC device is installed in the send path of a connection, it is recommended that any ALC devices in the receive path at the other end of the link be disabled.

In general, the earlier an ALC device occurs in a link, the greater the potential benefits are to the performance of network equipment. However, it may be economically advantageous to integrate the ALC device with an echo canceller [4] and [9]. Where choice permits, it is preferable to have an ALC device installed in the send path of a connection rather than the receive path, since intermediate equipment may then benefit from the tighter control of levels. In principle, it is feasible to have an ALC device installed in the receive path, after the echo canceller. However, such a choice is unlikely, since the echo canceller itself would not then benefit from the level control.

With due regard to the stability issues discussed in 7.1, it would be possible to use ALC devices in connections with echo suppressors (as opposed to echo cancellers). The performance tests described in the main text of this Recommendation should be made with the appropriate echo control device installed in the test circuit.

Again with regard to the stability issues discussed in 7.1, and also with due regard to the echo performance of ALC devices discussed in 7.2, it would be possible to install an ALC device in the send direction of a national network. In many such networks, transmission delays are too short to justify the use of echo control devices for national calls. For reasons of stability, if the ALC device in the national network does not incorporate an in-built echo canceller, it may not be permitted to introduce as much gain as an ALC device in the international network (see 7.1, Stability).

If an Administration chooses to install ALC devices in its national network, it raises the prospect of such an ALC device occurring in cascade with other ALC devices in the international network. Cascaded (tandemed) operation of ALC devices is undesirable for the reasons given above.

Also, in an international connection, the ALC device in the national network may be in the tail-path of an echo canceller. This may affect the performance of the echo canceller because it introduces gain changes to the echo path. In the case of networks that use full echo cancellers, if the ALC device is not integrated into the design of the echo canceller, there is no alternative but to site the ALC device in a tail-path of the canceller. The use of ALC devices in networks incorporating full echo cancellers is for further study.

II.2 Tandemed operation

There are significant issues relating to the tandemed operation of ALC devices. Until ALC devices have the capability of being disabled to prevent them from operating in tandem, they should be implemented in such a fashion that tandeming cannot occur.

ITU-T RECOMMENDATIONS SERIES

Series A	Organization of the work of the ITU-T
Series B	Means of expression: definitions, symbols, classification
Series C	General telecommunication statistics
Series D	General tariff principles
Series E	Overall network operation, telephone service, service operation and human factors
Series F	Non-telephone telecommunication services
Series G	Transmission systems and media, digital systems and networks
Series H	Audiovisual and multimedia systems
Series I	Integrated services digital network
Series J	Transmission of television, sound programme and other multimedia signals
Series K	Protection against interference
Series L	Construction, installation and protection of cables and other elements of outside plant
Series M	TMN and network maintenance: international transmission systems, telephone circuits, telegraphy, facsimile and leased circuits
Series N	Maintenance: international sound programme and television transmission circuits
Series O	Specifications of measuring equipment
Series P	Telephone transmission quality, telephone installations, local line networks
Series Q	Switching and signalling
Series R	Telegraph transmission
Series S	Telegraph services terminal equipment
Series T	Terminals for telematic services
Series U	Telegraph switching
Series V	Data communication over the telephone network
Series X	Data networks and open system communications
Series Y	Global information infrastructure
Series Z	Languages and general software aspects for telecommunication systems