



INTERNATIONAL TELECOMMUNICATION UNION

ITU-T

TELECOMMUNICATION
STANDARDIZATION SECTOR
OF ITU

F.702

(07/96)

SERIES F: NON-TELEPHONE TELECOMMUNICATION
SERVICES

Audiovisual services

Multimedia conference services

ITU-T Recommendation F.702

(Previously "CCITT Recommendation")

ITU-T F-SERIES RECOMMENDATIONS
NON-TELEPHONE TELECOMMUNICATION SERVICES

TELEGRAPH SERVICE	F.1-F.109
Operating methods for the international public telegram service	F.1-F.19
The gentex network	F.20-F.29
Message switching	F.30-F.39
The international telemesssage service	F.40-F.58
The international telex service	F.59-F.89
Statistics and publications on international telegraph services	F.90-F.99
Scheduled and leased communication services	F.100-F.104
Phototelegraph service	F.105-F.109
MOBILE SERVICE	F.110-F.159
Mobile services and multideestination satellite services	F.110-F.159
TELEMATIC SERVICES	F.160-F.399
Public facsimile service	F.160-F.199
Teletex service	F.200-F.299
Videotex service	F.300-F.349
General provisions for telematic services	F.350-F.399
MESSAGE HANDLING SERVICES	F.400-F.499
DIRECTORY SERVICES	F.500-F.549
DOCUMENT COMMUNICATION	F.550-F.599
Document communication	F.550-F.579
Programming communication interfaces	F.580-F.599
DATA TRANSMISSION SERVICES	F.600-F.699
AUDIOVISUAL SERVICES	F.700-F.799
ISDN SERVICES	F.800-F.849
UNIVERSAL PERSONAL TELECOMMUNICATION	F.850-F.899
HUMAN FACTORS	F.900-F.999

For further details, please refer to ITU-T List of Recommendations.

FOREWORD

The ITU-T (Telecommunication Standardization Sector) is a permanent organ of the International Telecommunication Union (ITU). The ITU-T is responsible for studying technical, operating and tariff questions and issuing Recommendations on them with a view to standardizing telecommunications on a worldwide basis.

The World Telecommunication Standardization Conference (WTSC), which meets every four years, establishes the topics for study by the ITU-T Study Groups which, in their turn, produce Recommendations on these topics.

The approval of Recommendations by the Members of the ITU-T is covered by the procedure laid down in WTSC Resolution No. 1 (Helsinki, March 1-12, 1993).

ITU-T Recommendation F.702 was prepared by ITU-T Study Group 1 (1993-1996) and was approved under the WTSC Resolution No. 1 procedure on the 19th of July 1996.

NOTE

In this Recommendation, the expression "Administration" is used for conciseness to indicate both a telecommunication administration and a recognized operating agency.

© ITU 1997

All rights reserved. No part of this publication may be reproduced or utilized in any form or by any means, electronic or mechanical, including photocopying and microfilm, without permission in writing from the ITU.

CONTENTS

	<i>Page</i>
1	Introduction..... 1
2	Definition 1
3	References and terminology..... 1
3.1	References 1
3.2	Terminology 2
4	Description 2
4.1	General description..... 2
4.2	Functional model 3
4.3	Configuration..... 4
4.4	Roles of the participants 5
4.5	Terminal aspects 7
4.6	Applications..... 8
4.7	Supplementary services 8
5	Static aspects 8
5.1	Service level..... 8
5.1.1	General aspects of the service..... 8
5.1.2	Quality of service..... 8
5.1.3	Security aspects..... 10
5.1.4	General charging principles 10
5.2	Communication task level 10
5.2.1	Communication tasks used for the service..... 10
5.2.2	Quality of service..... 10
5.3	Media component level..... 11
5.3.1	Media components used for the service..... 11
5.3.2	Quality of service..... 11
6	Dynamic aspects..... 12
6.1	Activation phase 12
6.1.1	Provision, withdrawal 12
6.1.2	Call establishment..... 12
6.1.3	Reservation 12
6.1.4	On demand..... 13
6.2	Communication phase..... 13
6.2.1	Call set-up..... 13
6.2.2	Addition of another party during the call..... 13
6.2.3	Conference splitting 14
6.2.4	Change of communication mode 14
6.2.5	Call prolongation in the case of reservation..... 14
6.2.6	Terminal disconnection..... 15
6.2.7	Conference management procedures 15
6.3	Termination phase 16
6.3.1	Call termination..... 16
7	Service profiles..... 17
7.1	Different types of multimedia conference services..... 17
7.2	List of service profiles 17

	<i>Page</i>
8 Interworking and intercommunication	19
8.1 General.....	19
8.2 Interworking/intercommunication between two terminals	19
8.2.1 Different types of audiographic conference terminals	19
8.2.2 Audiographic conference and videoconference terminals	19
8.2.3 Different types of videoconference terminals	19
8.2.4 CDH and other types of terminals.....	19
8.3 Interworking/intercommunication between several terminals	19
8.3.1 Different types of multimedia conference terminals.....	19
8.3.2 Videophone and other multimedia conference terminals, multimedia conference and videophone terminals	20
8.3.3 Addition of a telephone terminal	20
8.3.4 Communication with a facsimile terminal	20
Annex A – Multipoint Conference Units (MCUs)	20
A.1 General.....	20
A.2 Call control functions	22
A.3 Conference control functions	22
A.4 Handling the various media components	23
A.5 Distributed MCU functions	23
A.6 Ports and interfaces.....	25
A.7 Interworking/intercommunication	25
Appendix I – Control of multiple windows	25
I.1 General.....	25
I.2 Starting, stopping and organizing multiple windowing	25
I.3 Selection of the windows' contents	25

MULTIMEDIA CONFERENCE SERVICES

(Geneva, 1996)

1 Introduction

The purpose of this Recommendation is to define the generic multimedia conference service and to describe their general features, regardless of the network environment in which these services are provided. These services allow conversational communication between several users in two or more locations. The generic multimedia conference service is one of the generic service types identified in Recommendation F.700, and its description follows the methodology described therein. The user requirements for the various applications supported by the service are translated into generic service specifications, independent of the constraints of specific implementations. Thus this Recommendation sets out the requirements that will satisfy the users' needs and allow proper intercommunication on an international basis of services offered by different providers and of equipment from different manufacturers.

Various instances (profiles) of this generic service are considered here with a network independent view. Specific service descriptions for each network will be issued in other Recommendations. The detailed technical specifications of the terminal, network and protocol aspects for each of them are described in dedicated Recommendations of the H.200-, H.300-, H.400-Series, and of the T.120-Series for specific multipoint protocols.

Along with the F.700 methodology, the description relies on the media components and the communication tasks described respectively in Annex A/F.700 and Annex B/F.700. These are service independent modular communication capabilities.

2 Definition

The multimedia conference services provide real-time transmission of voice together with motion video and/or various types of multimedia information between groups of users in two or more locations. The documents exchanged may contain all information types. When moving pictures are present, their quality must be at least sufficient for the adequate representation of the fluid movements of a small group of participants. The media components used are described in Annex A/F.700 on audiovisual/multimedia services. Media component audio (A.1/F.700) is mandatory, and one or more of the media components video (A.2/F.700), text (A.3/F.700), graphics (A.4/F.700) and still pictures (A.5/F.700) should be present.

3 References and terminology

The following Recommendations and other references contain provisions which, through reference in this text, constitute provisions of this Recommendation. At the time of publication, the editions indicated were valid. All Recommendations and other references are subject to revision: all users of this Recommendation are therefore encouraged to investigate the possibility of applying the most recent edition of the Recommendations and other references listed below. A list of the currently valid-ITU-T Recommendations is regularly published.

3.1 References

- ITU-T Recommendation F.700 (1996), *Framework Recommendation for audiovisual/multimedia services.*
- ITU-T Recommendation G.114 (1996), *One-way transmission time.*
- CCITT Recommendation G.711 (1988), *Pulse Code Modulation (PCM) of voice frequencies.*
- CCITT Recommendation G.722. (1988), *7 kHz audio-coding within 64 kbit/s.*
- ITU-T Recommendation T.120 (1996), *Data protocols for multimedia conferencing.*

3.2 Terminology

For the purposes of this Recommendation, the following definitions apply.

3.2.1 audiographic conference service: An international service, offered by Administrations, enabling participants to conduct a real-time multimedia conference in which audio signals are exchanged together with non-voice graphics information, without motion video.

3.2.2 chairman: The user who chairs the meeting and manages the conference.

3.2.3 collaborative document handling service (CDH): A service that provides bidirectional transfer of data between two or more locations so that users are able to work on a common document, for drafting or amending it collectively.

3.2.4 communication modes: A communication mode is defined by the various channels supporting the media used for the conference. Changes in communication mode may occur during the course of the conference, in order to set up or eliminate one of the media, or to change its quality level and thus the bit-rate allocation. It may be used for instance to temporarily add a channel for transmitting still pictures.

3.2.5 conference controller: The user who manages the call during the conference.

3.2.6 conference convener: The user who has organized the conference.

3.2.7 conference room: In this Recommendation, the expression, conference room, refers to any location where a multimedia conference terminal is located. This may be a specially prepared group conference facility or an individual desktop terminal.

3.2.8 multipoint conference unit (MCU): Equipment that provides multipoint connections among three or more conference rooms.

3.2.9 muting: Preventing sound to be transmitted from a terminal equipment.

3.2.10 presenter: The participant in a conference who controls the visual information being actively discussed.

3.2.11 videoconference service: An audiovisual conversational conference service providing bidirectional real-time transfer of voice and motion video between groups of users in two or more separate locations. Although the audio and motion video information are the essential part of the service, other types of information, such as high resolution still pictures, text or graphics may also be exchanged.

3.2.12 videophone service: An audiovisual conversational service providing bidirectional symmetric real-time transfer of voice and motion video between two locations. The minimum requirement is that under normal conditions the picture information transmitted is sufficient for the adequate representation of fluid movements of a person displayed in head and shoulders view.

4 Description

4.1 General description

A multimedia conference service provides real-time communication between several users in different locations, combining a good audio facility with motion video of participants and/or transmission of multimedia information. The service is applicable to companies' private conference rooms as well as to public-access conference rooms for hire on an occasional basis. It is applicable to a variety of types of multimedia conference terminals such as:

- dedicated studios equipped for multimedia conferences;
- multipurpose meeting rooms used only part-time for teleconferencing;
- portable or roll-about equipment which can be moved from one room to another to provide temporary service;
- terminal equipment for individual participants, e.g. microcomputer based terminals.

The service is bidirectional via telecommunication networks, and provides for interconnection of two or more multimedia conference terminals on an equal basis. Other types of terminals may be added to the conference, such as videotelephones or even plain telephones; although they will usually have some limitations on the capability to send and receive all the different types of information used in a multimedia conference call, they will at least be able to exchange speech allowing their users to take part in the discussion; this is described in clause 8 on intercommunication.

When the conference includes more than two terminals, a Multipoint Conference Unit (MCU) is usually required. All locations are connected individually to an MCU which elaborates a selection or the appropriate combination of these signals for each of the locations, and manages the signalling and the optional channels.

Multimedia conference services are essentially built around the communication task conferencing described in B.2/F.700. Other communication tasks (receiving and sending) are optional.

4.2 Functional model

In a multimedia conference, two or more terminals exchange multimedia information through an interconnection system, under the control of a control unit (Figure 1). The interconnection system includes equipment for switching and/or combining the information from the different terminals and one or several networks.

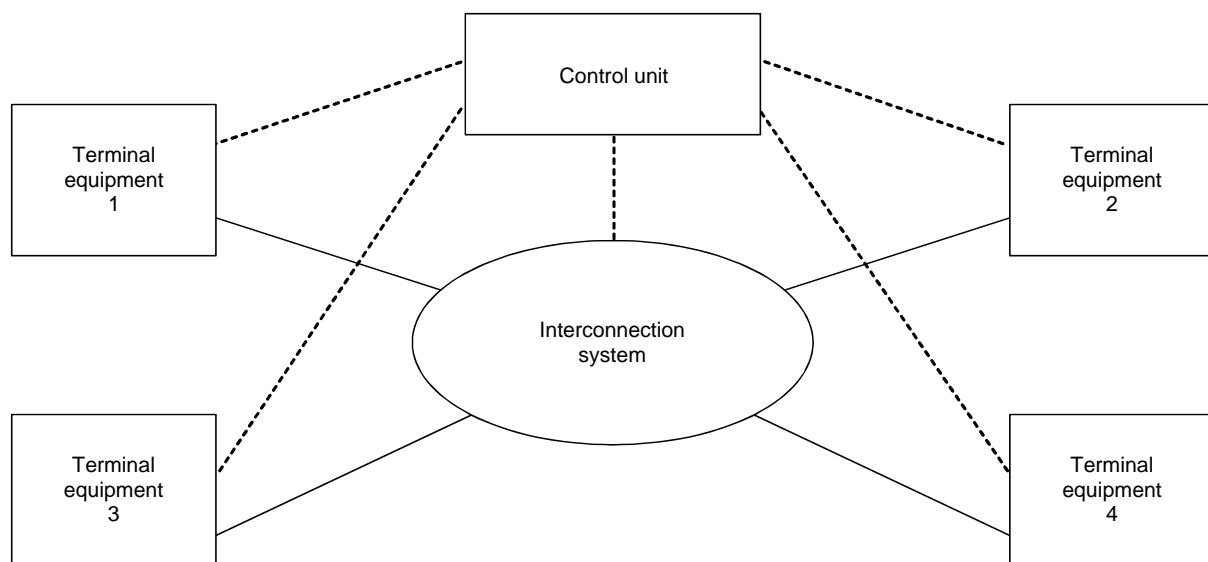

T0104700-95/d01

————— User information
 - - - - - Control signals (call control and conference control)

NOTE – The physical boundaries of equipment are independent from the functional boundaries shown on the figure. For instance an MCU usually includes a control unit and other units, dedicated to the various media components, which perform switching and/or combining actions and functionally belong to the interconnection system.

In the special case where there are only two terminals, they are connected point-to-point and a control unit is not needed.

FIGURE 1/F.702
Functional model

4.3 Configuration

The configuration may be point-to-point between two multimedia conference rooms, or multipoint-to-multipoint between several. In the latter case the terminals are usually connected through one or more Multipoint Conference Units (MCUs). The MCUs have to fulfill three functions:

- a) managing the call, setting up and closing the connections;
- b) managing the conference, through control and indication signals exchanged with the terminals;
- c) handling the signals received and sent on each connection, switching, distributing, multiplexing and when necessary adapting and combining them as appropriate.

Types of configurations

The multipoint configurations can be subdivided into:

- multichannel multipoint;
- shared channel multipoint;
- switched multipoint.

Including the point-to-point configuration, the following four types of configurations may thus be set up (see Figure 2).

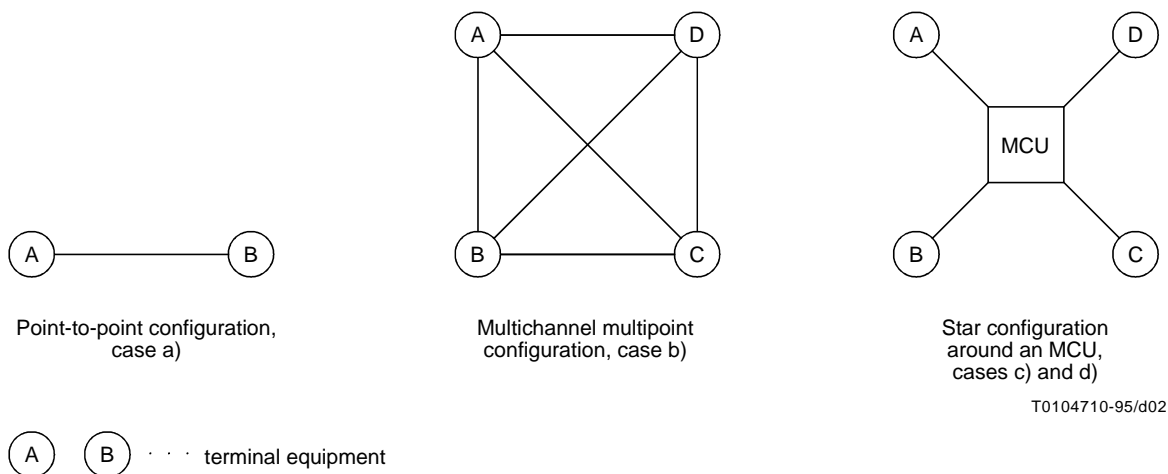

FIGURE 2/F.702

Types of configurations

Case a) Point-to-point configuration

Two conference rooms are directly connected (without any MCU). Conference management is by bilateral negotiation between the terminals.

Case b) Multichannel multipoint configuration

Three or more multimedia conference rooms are connected two-by-two so that each of them receives the signals from all the others, and may use them in various ways. For instance the sounds may be mixed or directed to separate loudspeakers. If video is present, each terminal permanently receives the images from all other locations and displays them simultaneously on separate screens or on different windows of a unique screen. Various schemes may be used for exchanging documents. Limitation to the number of participants comes from the number of channels available in each location and the number of equipment for presenting the information to the users (or the number of inputs to these equipment), e.g. the number of images that can be displayed simultaneously by the terminal equipment. An MCU is not mandatory, but it may be used for managing the conference.

Case c) Shared channel multipoint

This configuration requires a multipoint conference unit. This MCU receives signals from every terminal, and combines them to elaborate the signals sent out to each terminal. This may be done by multiplexing them in a higher bit-rate channel (e.g. four or five H0 channels into one H1 channel). It may also be achieved by mixing the sound signals, putting the various pictures into different windows (when applicable) and broadcasting the data channels if they are present. The MCU also processes the control and indication signals.

If the number of available multiplexed channels or the number of available windows for the video is smaller than the number of terminals minus one, then a selection must be made inside the MCU. This applies mainly to the pictures in a videoconference. The pictures may be chosen by each user, or by the Chairman if there is one, or they may be those of the latest speakers, or any combination of these. More details on this case are for further study.

Case d) Switched multipoint configuration

This configuration requires at least one multipoint conference unit. This MCU receives signals from every terminal; it selects according to predetermined rules or to specific commands the signals sent to each terminal; it handles the signalling, commands and indications, forwards them when necessary and returns the appropriate answers; it manages the optional channels and broadcasts the signals received on these channels.

Most often the switching only applies to the video signals, because data may be multiplexed into a common packet switched data channel and the sound signals are usually added in the MCU so that each terminal receives the sounds from all other terminals excluding its own; however, this addition process may be restricted to a few terminals in order to limit the noise level or the unwanted disturbances if the number of participants is large. Alternately, the sound may also be switched together with the image.

Several MCUs may be required for some configurations either for technical or for economical reasons. In this case, each terminal is connected to one of the MCUs; the MCUs are interconnected and handle the signals to and from other MCUs similarly as to and from an ordinary terminal.

From the network point of view, the connections that have to be established are as follows:

- case a) point-to-point;
- case b) several point-to-point connections linking all locations two-by-two;
- case c) several point-to-point connections between each location and the MCU, which may be non-symmetrical if the network supports this type of connection;
- case d) several point-to-point connections between each location and the MCU, and possibly between MCUs if several are used; a single or multiple point-to-multipoint connection(s) may also be used in networks that support them.

The four types of configurations are shown in Figure 2. Cases c) and d) are represented by the same diagram, but the functions of the MCU and the types of connections are different.

When several MCUs are involved, this should be transparent to the users, except through the increased transmission delays and the possible limitations due to the capability of the inter-MCU connections. In the following subclauses the term MCU will be used indifferently for a unique MCU or for several interconnected MCUs, unless otherwise stated. Figure 3 shows several functionally equivalent configurations where the MCU function is either concentrated in one location or distributed between several.

4.4 Roles of the participants

A participant may be allocated two types of particular privileges that allow his terminal to issue special commands to which the MCU will respond by the appropriate actions. These give him respectively the roles of the controller and the Chairman.

The controller manages the call, and may perform the following:

- accept new participants;
- disconnect a participant from the call;
- split the conference if this possibility is offered;

- terminate the call;
- ask for a continuation of the call beyond the reserved time.

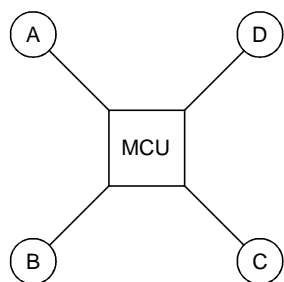

Star configuration around an MCU



Configuration with 2 MCUs

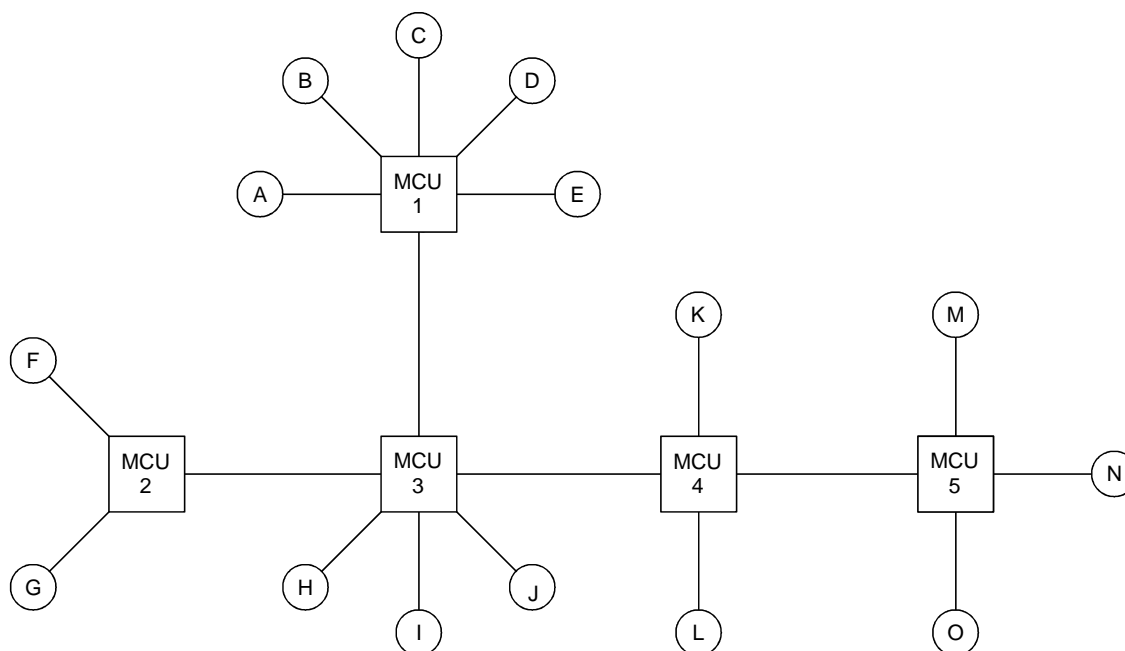

Multi-MCU configuration

T0104720-95/d03

FIGURE 3/F.702

Functionally equivalent configurations with single or multiple MCUs

The Chairman manages the conference, and may perform the following:

- give the floor to a participant;
- mute another terminal;
- organize or allow a private talk;
- possibly allocate the right to transmit other information, although this facility control function may also be separately assigned.

These two roles may be assigned to the same terminal or to different terminals. At the beginning of the call, the controller is usually the convener, but he may transfer this role to another terminal (see Note).

Other participants may ask for the floor or for the authorization to transmit data, and the MCU forwards these requests to the chair-terminal.

NOTE – Some MCUs may not be able to separate the two roles of controller and Chairman. In that case they should then be able to allocate the same joint controller-Chairman function to two different terminals (e.g. by issuing two identical tokens), and it will be left to both users to each perform only the functions pertaining to his role. Indeed this may be a preferred solution, because it allows the Chairman to leave to the controller some of the functions (for instance data management) that he may not be willing to perform; the Chairman may then have an easy terminal, to use with only very few controls.

4.5 Terminal aspects

In order to perform the basic functions necessary for multimedia conference services, the terminal equipment must include the following units necessary for audio communication:

- one (or more) microphone(s);
- one (or more) loudspeaker(s);
- an audio codec;
- audio related controls;
- some means for identifying the speaker.

The terminal must also include a control module to which these units will be connected, and a network interface unit. The other types of information require specific equipment detailed below. The terminal should include the equipment(s) for at least one media component besides audio.

The equipment for handling multimedia documents includes one or more of the following functional units:

- a microcomputer with a screen and optionally a printer;
- a still picture equipment with a camera or scanner, a screen and/or a printer;
- a telewriting equipment;
- a facsimile equipment.

The basic equipment for video includes:

- one (or more) camera(s);
- one (or more) screen(s);
- a video codec.

When video is present, means must be provided for displaying the outgoing picture, either permanently or by substituting it on the screen to the incoming picture. If sound and/or image sources are locally switched, then an indication must be given of which one is sent out.

NOTE – Testing of the outgoing picture: it should be possible for the user to put an off-line terminal into a self-test procedure, which includes the codec, in order to test and control the outgoing picture.

Possible enhancements to the equipment in each location are for example:

- voice switched or manually switched multiple microphones;
- multiple cameras performing some of the following functions:
 - overall view of the room;
 - partial views of the assembly;
 - views of individual participants;
- the pictures from these cameras may be switched or combined in different windows;
- additional dedicated cameras;
- multiple screens, for instance for displaying side-by-side the different windows;
- zooming and panning;
- far-end camera control;
- various indications such as identification of the displayed location in a multipoint conference;

- controls for conducting the conference, asking for the floor, etc.;
- auxiliary cameras for viewing a blackboard, objects, etc.;
- videotape recorder for displaying and sending any sequence of images, or recording the meeting;
- telewriting facility;
- pointer;
- multiple loudspeakers;
- equipment for encryption and decryption of user signals.

4.6 Applications

Some possible applications are indicated here as examples:

- uncondacted meeting between distant parties;
- formal conducted meeting between distant parties;
- panel discussion;
- elaboration of a document, with or without cooperative document handling;
- presentation of a report in a large company with subsequent discussion;
- presentation of an object (e.g. a new product) and comments on this;
- negotiation of a contract with possible private discussions or advice from invited experts;
- lecturing;
- distant education or training;
- tele-auction sale.

4.7 Supplementary services

For further study.

5 Static aspects

5.1 Service level

5.1.1 General aspects of the service

Throughout the communication phase, the communication task conferencing is used with the media component audio and one or more other media components.

Retrieval of documents needed for the conference, either at the beginning or during the course of the conference may optionally be available; it uses the communication task receiving with one or more media components.

Storage of the documents drafted during the conference in a server, and/or transmission of copies to users outside the conference may also be offered; it uses the communication task sending, with one or several media components; it may be used with the media components audio and possibly video for storing in a server or sending to other users the records of the meeting.

The relationship between the three levels of the multimedia service reference model (service, communication tasks and media components) is shown in Figure 4 (see Recommendation F.700).

5.1.2 Quality of service

5.1.2.1 General considerations

The quality of service depends on the quality of each media component, of their association (e.g. synchronization of sound and image), of the control and procedures. It also depends on the combined quality of the various parts of the system and its environment.

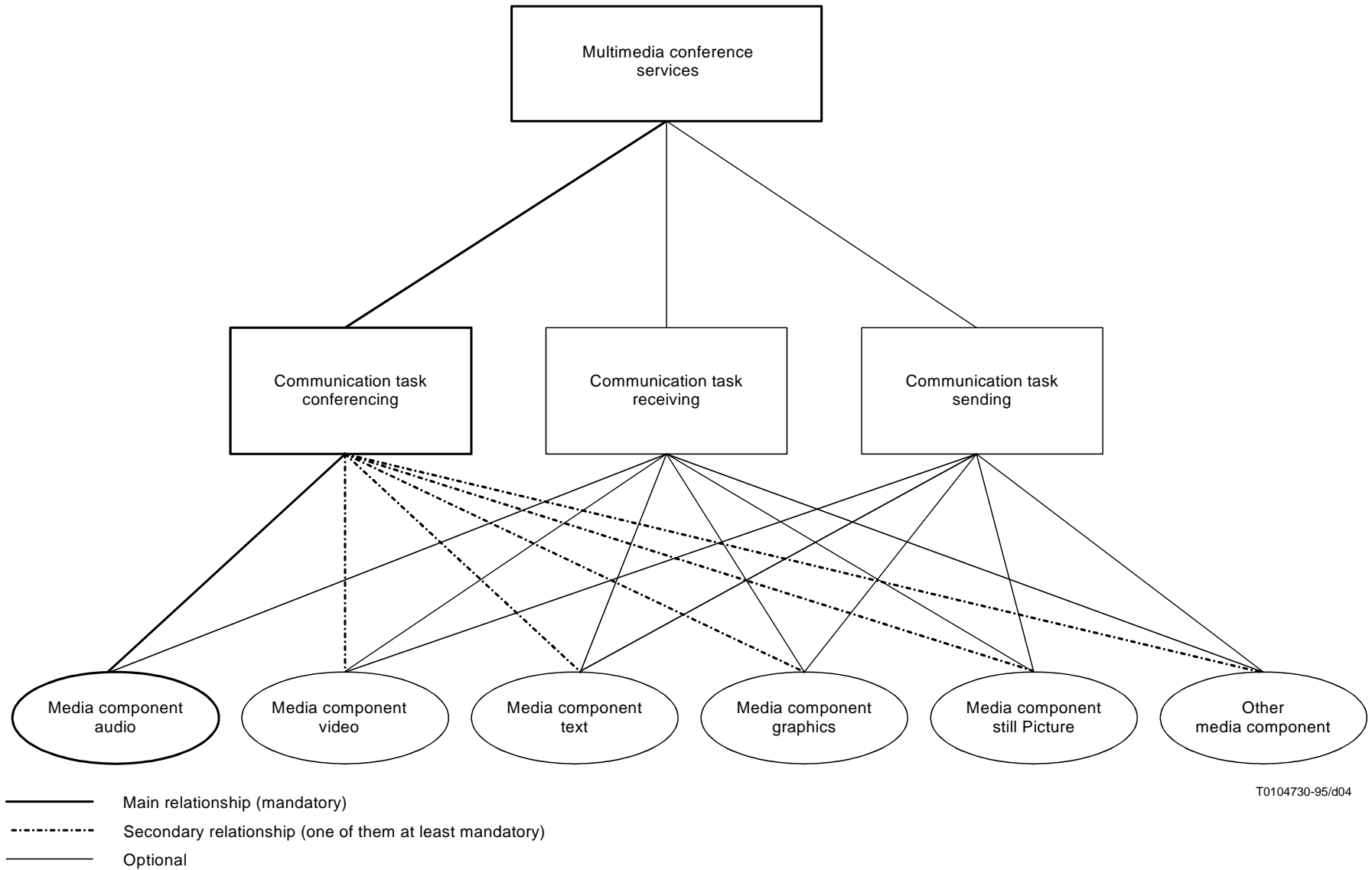

T0104730-95/d04

FIGURE 4/F.702

Relationships between service level, communication tasks and media components

Particular attention should be given to the MCUs. They support the main part of the complex multipoint procedures and are the crossroads of all signals. The degradation of the signals going through an MCU should thus be kept as low as possible, bearing in mind that it may build up in the case of cascaded MCUs.

5.1.2.2 Overall delay

The nominal overall delay is defined as the sum of the transmission delay and the characteristic delay of the conference terminals (see Note). When applicable, the characteristic delay of the MCU(s) must also be added. The subjective effect of this delay on the quality of service has to be taken into account because an excessive value may impair user acceptability.

Under normal conditions the overall delay should not exceed 400 ms when video is not present, in conformance with Recommendation G.114 for the audiographic conference service or CDH without video. Another Recommendation is expected for audiovisual services. However, when no means are available to fulfill this condition, the call should not be rejected.

NOTE – The characteristic delay of a terminal is the delay introduced by the terminal when the transmitted information contents for the various media is minimal; for the video, this means that there is no movement or only very small movements in the transmitted image, e.g. only lips and eyes of the users are moving.

5.1.3 Security aspects

Adequate means should be provided to avoid unauthorized intrusion in the conference call, for instance by authentication or screening of new entrants. Whenever possible, a participant should be able to know the identities of all the others, except in specific cases such as teleteaching or telelecturing where this possibility may be limited to the conference controller.

5.1.4 General charging principles

Three modes of charging should be offered:

- charging to one of the participants;
- shared charging where each participant is charged according to his participation;
- charging to a third party.

If charging is to the convener and he leaves the conference, other participants may continue without him, either with the same charging if the convener has accepted it beforehand, or charging to another participant who volunteers for it, or shared charging.

Optionally other possibilities may be offered, such as:

- multiple charging: several participants are charged, each for his own part and for the parties he invites;
- shared charging with invited parties: the part of the connection relevant to the invited party (or parties) is shared between the other parties, together with their own part.

After disconnection of one or several parties during the course of a conference, it may happen that a simpler and cheaper configuration would be available; if the change of configuration is possible, then it should be proposed to the users.

5.2 Communication task level

5.2.1 Communication tasks used for the service

Multimedia conference services are built around the communication task conferencing (see Annex B.2/F.700). Other tasks such as receiving and sending may also be used for specific purposes (see 5.1.1).

5.2.2 Quality of service

5.2.2.1 Differential delay between sound and image

When video is present, the differential delay between sound and image should be kept low enough for lip synchronism to be subjectively insured.

5.3 Media component level

5.3.1 Media components used for the service

The media component audio (see Annex A.1/F.700) is set up at the beginning of the call and is usually present throughout, but it may be temporarily interrupted to increase the bit rate available for other media components.

One other media component at least should also be present, permanently or not, i.e. one of the following components:

- Video (A.2/F.700).
- Text (A.3/F.700).
- Graphics (A.4/F.700).
- Still pictures (A.5/F.700).
- Others (for further study).

5.3.2 Quality of service

5.3.2.1 Sound quality

The following two levels of sound quality are preferred:

- the basic quality is 7 kHz bandwidth (conforming to Recommendation G.722) equivalent to present broadcast TV sound (level 1 of media component audio);
- the high quality is stereophonic and should be at least 7 kHz and preferably 15 kHz bandwidth (level 1 or 2 of media component audio).

A lower quality, equivalent to that of the PCM telephony conforming to Recommendation G.711 (level 0 of media component audio) may also be used if there are difficulties or technical constraints in using the higher levels, or in intercommunication situations, or for short periods while priority is given to fast transfer of other types of information.

For the quality levels of the media component audio, see A.1/F.700.

Means for efficient echo control must be provided. When video is present, these means should have the capability to accommodate the large transmission delay that may be induced by the synchronization of sound and image (see 5.2.2).

5.3.2.2 Image quality for the video

When video is present, its quality must be sufficient for reproducing the fluid movements of a small group of people sitting at a table (see Note). Three grades of image quality may be offered:

- basic videoconference quality: at least two persons with only small movements can be viewed; this is level 2 of the media component video;
- enhanced quality videoconference: the quality should be that of broadcast TV; this is level 3 of the media component video;
- high quality videoconference: the quality should be that of HD-TV; this is level 4 of the media component video.

For the quality levels of the media component video, see A.2/F.700.

A factor of quality related to video is the recovery time for picture build-up when the video source is changed; it must be kept low enough to avoid any disturbance to the meeting. Precise values are for further study.

Complete definition and methods of evaluation of the quality of motion pictures require further studies.

NOTE – When motion video is present, the smoothness of the movement in the displayed image depends on the ability of the system to convey rapid changes; the amount of information which has to be transmitted will of course increase with the affected area in the picture and the speed of the movement. It is generally considered that in a normal videoconference environment, only part of the picture will be moving and that any fast movement will be limited to a very small portion of the image. Some degradation of the picture quality such as jerkiness, blurring or other artifacts may be allowed during the brief and exceptional instants when these conditions are not met.

6 Dynamic aspects

6.1 Activation phase

6.1.1 Provision, withdrawal

The multimedia conference services may be provided after prior arrangement with a service provider, or they may be generally available.

6.1.2 Call establishment

Call establishment may be by reservation or on demand.

6.1.3 Reservation

Reservation may be made from any multimedia terminal taking part in a conference. It may also be made from another terminal which could be for instance a simple telephone or videophone terminal, a computer with communication facilities, a videotex terminal or a fax. Reservation may also be made by a third party.

To allow reservation through any of these terminals, three modes of reservation should be offered:

- automatic reservation, through a computer with appropriate communication facilities or a multimedia terminal with equivalent capabilities;
- simplified automatic reservation, through audiotex or videotex;
- manual reservation, through an operator called from a telephone or other audiovisual terminal or by fax; the operator will then enter the reservation into the automatic system.

In all three cases, the information required from the user should be identical and the procedures should be equivalent, and as far as possible independent of the type of multimedia conference. The conditions of reservation should also be the same (minimum delay between reservation and conference, conditions for cancellation or modification of the demand, conditions for early termination or prolongation, etc.). It is important for the user that the procedures from the different terminals and for the different types of multimedia conferences be harmonized as much as possible, so that a user will not have to learn the use of different procedures.

An acknowledgement listing all the parameters of the reservation should be sent to the user whenever possible (i.e. if the user has a terminal suitable for this acquitment and known to the reservation server).

The information required for reservation are:

- date and time of the proposed conference;
- duration or time for ending the conference;
- type of multimedia conference and quality level;
- access numbers of participating terminals;
- in-call modifications, if offered by the network and MCU (additions, disconnections, splitting, change of type);
- additional functions required (any function not offered by the basic MCU);
- billing process (to one user, shared or other) and identification of the charged user(s).

The following parameters will be defined in other Recommendations or agreed between Administrations:

- minimum booking period;
- incrementation steps for defining the booking period;
- minimum notice time for booking;
- conditions and possible charges for cancelling or postponing the conference, or for changing information given at booking time;

- conditions and charges for in-call modifications not defined when the reservation was made;
- conditions and charges for prolongation or early termination of the call.

6.1.4 On demand

Three types of procedures may be offered for direct dialling:

- 1) point-to-point calls for establishing direct point-to-point connections between terminals;
- 2) meet me conference calls where each participant calls the MCU at a pre-arranged time;
- 3) add-on conference calls where the convenor calls the MCU and then the participants; alternately, the MCU may call the participants from a list transmitted by the convener or previously stored; a particular instance of this call procedure is the supplementary service preset conference, in which the user dials a specific abbreviated number causing the MCU to call a preset list of terminals.

For the meet me conference, arrangements also have to be made for reservation of the MCU, or at least recognition of calling terminals by the MCU. Reservation of the MCU requires the same information as for complete reservation, or a subset of these (e.g. the number of participants may be needed but not their identity). Means for authentication are essential in order to prevent intrusion.

6.2 Communication phase

6.2.1 Call set-up

In the case of reservation, the connections are established at the agreed time; if the terminals are already on, they will immediately enter the conference set-up phase; otherwise they will do so when they are switched on.

In the on-demand establishment, the ordinary call set-up procedure is used in the first case (point-to-point configuration).

Procedures for the other two configurations are left for further study.

6.2.2 Addition of another party during the call

6.2.2.1 Reservation case

In case of reservation, the additional connection is made at the scheduled time if defined at the time of booking, and set-up proceeds as above. An unscheduled addition may also be requested; it may be made by direct dialling if this is offered; otherwise the conditions are for further study.

6.2.2.2 On-demand case

During the course of the conference, a call can be made to another terminal in order to make it participate; this may be done by any party, but has to be accepted by the conference controller or by the party being charged for the conference; in case of shared billing, the new entrant must be advised that he will have to pay for his share.

Conversely, a user external to the conference may ask for entry; this has to be accepted by the party being charged for the conference, or by the convener in case of shared billing.

In both cases, all participants must be advised of the identity of the newcomer; the latter should be advised of the identities of all the parties already present and of the billing status. Addition of a new party is dependent on the availability of network and MCU resources. In case of denial, the caller should be advised of the reason.

If the new terminal is not compatible with the type of the current conference, it may enter by one of the intercommunication or interworking processes described in clause 8, or the participants may be given the choice to change the type of their conference if the MCU supports it.

6.2.3 Conference splitting

6.2.3.1 Conference splitting in case of reservation

During the course of the conference, users may want to split into two or more groups. If this optional feature is supported by the MCU, it may be made at a preset time, in which case the users will be advised a few minutes beforehand; the time may also be left open, and it is then initiated by the convenor or the Chairman.

Resuming the initial conference may be made at a preset time, or may be allowed at any time. In both cases the participants should receive some appropriate warning beforehand.

Unscheduled splitting may also be offered, but is then dependent on the availability of network and MCU resources.

Detailed procedures are for further study.

6.2.3.2 Conference splitting in case of on-demand establishment

If the MCU can support it, the possibility of splitting the conference may be offered to the users; this may, however, be conditioned by the availability of network and MCU resources; nevertheless, temporary exclusion of one or more participants so that the others may have a private conversation does not require any additional resources and should then always be granted.

Resuming the initial conference will be allowed at any time. The participants should receive some audible warning.

6.2.4 Change of communication mode

Changes in user requirements arising during the course of the conference may require a change of communication mode, i.e. changes in the network connections or changes in the in-band channel that are transparent to the network. If the network and MCU support it, then in-call change of mode should be allowed when all the terminals have the capabilities for the new mode; this may be initiated by the controller or the convener. If it requires additional network resources, then it is subject to the availability of these resources, unless the conference has been set up by reservation and provisions have been made for the change when making the reservation.

If some of the terminals do not have the capabilities required for the new mode, then the requesting party should be informed and given the choice between one of the following courses supported by the system:

- a) the request may be abandoned;
- b) the change may be made using one of the intercommunication or interworking processes described in clause 8;
- c) if the MCU does not support terminals with secondary status, then the requested mode may be established between the terminals that have the required capabilities while the other terminals are temporarily excluded from the conference;
- d) alternately a less demanding mode may be proposed.

Ideally this would be an automatic feature of the service that would allow fall-back to a predetermined or highest common level of capability unless the user makes an explicit choice.

6.2.5 Call prolongation in the case of reservation

In case of reservation, the convenor, or any participant in the case of shared billing, can ask for a prolongation of the call beyond the reserved time; this may be granted or not according to the availability of the network or the MCUs. Detailed procedures are for further study.

6.2.6 Terminal disconnection

Each participant may disconnect his terminal at any time.

6.2.7 Conference management procedures

6.2.7.1 Conference set-up

Each terminal exchanges with the MCU all the information relevant to the operation of the conference that it is capable of handling; it may include the following:

- terminal identification (access number, location, company, etc.);
- identification of participants (names, company, etc.);
- terminal capabilities.

As soon as a terminal has completed conference set-up, it is considered active and should be sent an appropriate indication. All other active terminals should be informed of its entry in the conference, and it should receive a list of all the already active terminals (see 6.2.7.5 for exceptions to this rule).

6.2.7.2 Conference modes

There are two conference modes, conducted and unconducted. They are described in B.2/F.700.

6.2.7.3 Audio muting and video inhibition

Any participant may temporarily prevent his terminal from sending out audio or video signals. A suspended video should be replaced by an adequate notice. A terminal should provide a visual indication when its audio is muted or its video inhibited.

6.2.7.4 Checking the list of participants

Every participant may at any time request to check the identity of the other participating terminals. Except in special types of conferences (see 6.2.7.5), he should then receive a list of the terminals active in the conference at that moment.

6.2.7.5 Participants with special status

It may be possible to distinguish certain categories of participants and to give them different status, either permanently or temporarily. Examples are given hereafter.

Members and auditors

Members are able to take the floor at any time whereas auditors have to be given the floor by the Chairman. This feature can be used for instance if there is a panel whose members are allowed to speak freely, while in the audience only one auditor at a time is allowed to ask a question. Additionally, if the number of participants is large, mixing the voices of the panel members only will limit the addition of noise to a small number of sources and avoid unwanted disturbances.

Anonymous participants

In a public meeting, e.g. a lecture, a show or an auction sale, some or all participants may be allowed to remain anonymous, i.e. they will not be seen by other participants except the controller or the Chairman, and their names or other identification will not be made available either.

6.2.7.6 Videoconference with multiple pictures

Multiple pictures may be transmitted by various means. At the receiving end, they may be displayed on multiple screens or in windows on one screen.

If the number of screens or windows is sufficient, then every participant can be viewed permanently in all locations and no switching is necessary. This is called continuous presence. In most cases however, the number of subpictures is smaller and a selection has to be made. The selection may be operated by the participants or automatically or a mixture of both. The criteria for automatic selection are an implementation matter (e.g. latest speakers, or Chairman and latest speakers, or members of a panel, etc.). However, the following rules should be applied:

- preferably only one window should be changed at a time, or two subpictures interchanged (e.g. if one window is larger than the others);
- the number of subpictures should be limited in order to keep them large enough;
- when the MCU is using several windows, a terminal should not be allowed to split them into smaller windows;
- the commands, if available, should be kept simple to use and should not be a burden on the Chairman.

Appendix I shows possible commands and procedures for controlling multiple subpictures.

6.2.7.7 Access to other services

6.2.7.7.1 General

There are two ways of accessing other services:

- access by one of the participants, who forwards the multimedia documents or information received to the other participants in the conference; this requires an additional access to the network, the appropriate rights of access to the service and possibly specific rights for forwarding documents to other users; the service may be public or private, e.g. retrieval of multimedia documents from a private server;
- access through the MCU, which then has to provide an access to the network, rights of access to the service (unless it can use the rights of one or several of the participants in the conference through some authentication procedure), and possibly conversion of protocols, of coding or of media.

6.2.7.7.2 Retrieval services

For further study.

6.3 Termination phase

6.3.1 Call termination

Call termination may be initiated:

- by the convener or controller;
- by the network or the MCU at the end of the reservation period; in this case participants should be given notice beforehand, allowing time for them to request for a prolongation;
- by the network when only one participant is left; before the call is terminated, he may be offered the possibility to make reservations for future conferences;
- by the network in the case of direct dialling, if resources are needed for setting up a reserved conference; in this case, the users should be given notice long enough in advance to leave them reasonable time for bringing their conference to a temporary end; optionally, they may be offered the choice of automatically resuming the conference (after prior notice) when resources will become available again.

7 Service profiles

7.1 Different types of multimedia conference services

All multimedia conference services have in common the capability for transmission of sound with a good quality. They can be divided into different types of profiles according to the other kinds of information exchanged:

- Audiographic conference, using various types of documents such as still pictures, graphics, texts, under different forms such as facsimile or files.
- Videoconference, with moving pictures and optionally all types of documents used in an audiographic conference.
- Collaborative Document Handling (CDH), using microcomputers with file transfer and joint editing capabilities.

Although possibly not supplying the same quality level, the videophone conference service is also included as a special case of a multimedia conference service. This service allows communication between three or more videophones, and thus belongs to the services enabling group communication. The multipoint connection may be established through the same types of MCUs as for the videoconference service.

7.2 List of service profiles

Taking into account the different types of facilities that may be used for handling documents, and the various options that may be offered, the following profiles of the generic multimedia conference service are defined. As stated in Recommendation F.700, these profiles are references for the offering of services, but do not preclude any enhancement or additional functions. Additional profiles may be added to respond to evolving user needs.

1) *Videoconference service*

- Profile 1a: Basic videoconference: wideband audio, CIF video for limited movements; conference conductor facilities are optional.
- Profile 1b: Standard videoconference service: wideband audio, CIF video, conference conductor facilities.
- Profile 1c: Enhanced videoconference: wideband audio, TV quality video, conference conductor facilities (see Note).
- Profile 1d: High quality videoconference: stereophonic audio, HD-TV quality video, conference conductor facilities (see Note).

2) *Audiographic conference service*

This service may be offered with two levels of audio quality and with three types of exchanged data. The minimum audio quality is level A0, equivalent to PCM telephony (profiles 2a); the basic audio quality is level A1, wideband audio. The three types of exchanged data are still pictures from a camera or equivalent system (profiles 2a1 and 2b1), fax pictures with hard copy capability (profiles 2a2 and 2b2), and microcomputer files (profiles 2a3 and 2b3).

- Profile 2a1: Basic audiographic conference with still pictures: basic audio, multipoint communication with still pictures, annotation and pointer.
- Profile 2a2: Basic audiographic conference with fax functions: basic audio, multipoint communication with fax.
- Profile 2a3: Basic audiographic conference with file transfer: basic audio, multipoint communication with file transfer.
- Profile 2b1: Standard audiographic conference with still pictures: wideband audio, multipoint communication with still pictures, annotation and pointer.
- Profile 2b2: Standard audiographic conference with fax functions: wideband audio, multipoint communication with fax.
- Profile 2b3: Standard audiographic conference with file transfer: wideband audio, multipoint communication with file transfer.

3) *Collaborative Document Handling (CDH)*

- Profile 3: Collaborative document handling: wideband audio, multipoint communication with file transfer and joint editing; optionally video (see Note).

4) *Videophone conference service*

- Profile 4a: Low bit-rate videophone conference: basic audio, minimum video.
- Profile 4b: Basic videophone conference: basic audio, basic video.

NOTE – The values shown for the profiles 1c, 1d and 3 are provisional.

Service	Profile	Audio	Video	Text, graphics and/or still pictures	File transfer	Control functions
VCS	P1a	A1	V2*	O	O	O
	P1b	A1	V2	O	O	M
	P1c	A1	V3	O	O	M
	P1d	A2	V4	O	O	M
AGCS	P2a1/2	A0	–	1M	O	M
	P2a3	A0	–	M	M	M
	P2b1/2	A1	–	1M	O	M
	P2b3	A1	–	M	M	M
CDHS	P3	A1	O	O	M	M
VPCS	P4a	A0	V0*	O	O	O
	P4b	A0	V1*	O	O	O
A0, A1, ... Minimum mandatory audio quality level V0, V1, ... Minimum mandatory video quality level V0*, V1* Minimum mandatory video quality level, with a limited amount of movement M Mandatory 1M One at least of the media components mandatory O Optional						

Note that additional profiles can be obtained by appropriate combinations of the above profiles:

- any combination of P2a1, P2a2 and P2a3 or P2b1, P2b2 and P2b3 provides an audiographic conference profile;
- P1a, P1b or P1c with any combination of P2b1, P2b2 or P2b3 provides a videoconference profile with data capability;
- P4 with any combination of P2a1, P2a2 or P2a3 provides a desktop videotelephone conference profile.

The following table recapitulates the requirements for the various types of profiles in terms of media components and their minimal levels of quality.

Media components	P1-VCS	P2-AGCS	P3-CDH	P4-VPH
Audio	A1	A0	A1	A0
Video	V2	–	O	V1 (*)
Text, graphics and/or still pictures	O	M	O	O
Data	O	O	M	O
A0, A1, V0, V1, V2 Are the minimal levels for audio and video M Mandatory (i.e. it must be available but not necessarily used) O Optional (*) If the low bit-rate videotelephony was also included, then the minimal video quality would be V0				

8 Interworking and intercommunication

8.1 General

Terminals with different characteristics and capabilities may be connected in a multimedia conference. Three ways of interworking or intercommunication may then be provided:

- use of a common mode which every terminal in the call can handle; this will decrease the quality and functionalities to those of the terminal with the lowest quality level for each media component; however, communication is always possible because all terminals have at least the basic audio capability;
- use of their normal mode for the terminals supporting higher quality levels, with partial functionalities only for the terminals with lower quality levels, which are thus given a secondary status; for instance some terminals may have audio and video while others may have audio capability only; it may also happen that terminals have different and incompatible data capabilities that they will not be able to use, e.g. facsimile and still pictures;
- transcoding in the MCU so that each terminal receives and transmits the signals it is able to handle.

8.2 Interworking/intercommunication between two terminals

This subclause describes various situations of interworking or intercommunication between two terminals. They are supposed to be either directly connected or through an MCU without transcoding capabilities.

8.2.1 Different types of audiographic conference terminals

These terminals can communicate with audio and with their common graphic components. In the worst case they may have incompatible graphic components and will then communicate with sound only.

8.2.2 Audiographic conference and videoconference terminals

If the videoconference terminal has no optional graphics components, then the communication can only use sound. If it has graphic components, then the situation is the same as above: those components that are common, if any, can be added to the common mode.

8.2.3 Different types of videoconference terminals

The higher level terminal can usually fall back to the lower level video mode. If this is not the case, then the common mode includes only sound.

If graphic components are present, then those that are common, if any, can be added to the common mode.

8.2.4 CDH and other types of terminals

CDH terminals may be considered as videoconference terminals with data handling if they have video capability, and as audiographic conference terminals if they do not; their intercommunication process is therefore the same as for these terminals.

8.3 Interworking/intercommunication between several terminals

8.3.1 Different types of multimedia conference terminals

There is often a choice between different modes. In some cases, the choice will be obvious and can be automatic, for instance when only one terminal has higher capabilities than the others. In other cases, choices may have to be made between a common mode with lower quality level and/or reduced functionalities, and higher quality with one or more terminals relegated to secondary status (if the MCU supports this).

A default mode may be automatically provided, but whenever there is a choice, the final decision should be left to the users.

The mode may also be changed during the course of the conference. For instance a basic videoconference terminal unable to handle multimedia documents may have to be temporarily excluded from the conference (or from the video medium) while the other terminals exchange documents. In an audiographic conference with different types of terminals, it may be decided at times to exchange files, giving secondary status to terminals that do not have this capability, and at other times to transmit facsimile documents, giving secondary status to other terminals that do not support this facility. It is a desirable feature that common mode arbitration be provided by the MCU on a default basis.

8.3.2 Videophone and other multimedia conference terminals, multimedia conference and videophone terminals

8.3.2.1 Audiographic conference and videophone terminals

These terminals can intercommunicate with sound only. Basic videophones have a lower quality level than audiographic conference terminals which will have to fall back to this lower level to establish communication. However, with broadband videophones, the situation may be the reverse. The ability to select one video picture in the video terminal or in the MCU for sending it as a still picture to the AGC terminal would be a desirable feature.

8.3.2.2 Videoconference and videophone terminals

If the video codecs have a common mode, then this can be used for intercommunication. However, with a basic videophone terminal, this may not be desirable because of the limited image quality, insufficient to show several participants simultaneously. The other possibility is then for the videoconference rooms to communicate between themselves in their usual mode, while the videophone terminal participates with sound only.

8.3.3 Addition of a telephone terminal

The capability for adding a telephone to a multimedia conference meeting should be offered. It will then participate with sound only, and possibly with any other terminal (e.g. facsimile, telewriting, etc.) that its user may have.

8.3.4 Communication with a facsimile terminal

The MCU may support the connection to a facsimile terminal. This entails the ability to extract the facsimile signals from the information received from other terminals in the conference in order to forward them to the facsimile terminal, and conversely to insert in the common data channel the information received from the facsimile terminal.

Annex A

Multipoint Conference Units (MCUs)

(This annex forms an integral part of this Recommendation)

A.1 General

In a multipoint conference between multimedia terminals, three or more terminals exchange audio, video and data signals, to which control and indication signals have to be added in order to ensure proper and harmonious progress of the conference. To provide multipoint communication among multiple terminals in the conference, the connections are usually established through one or several MCUs (Multipoint Conference Units): each terminal is connected to an MCU, and when several MCUs are present, connections are established between them.

The MCUs have to perform the following functions:

- a) controlling the call, i.e. establishing, modifying and releasing the connections, either directly or through the reservation system;
- b) controlling the conference, through control and indication signals exchanged with the terminals;
- c) handling, distributing and when necessary adapting (for instance transcoding) the signals transmitted by the terminals.

The functional model of an MCU is shown in Figure A.1. It includes the following modules:

- a control module performing the control functions;
- an audio module processing audio signals;
- a video module processing video signals;
- a data module processing text, still picture and graphics information;
- ports and interfaces.

A port is a functional entity that handles all the signals to and from an external system, i.e. a terminal, another MCU or a node in the network performing some distributed functions (see A.5).

Interfaces are the physical modules which adapt the signals entering or leaving the MCU.

It is not mandatory for an MCU to include all these modules. Some MCUs may be dedicated to a specific service or to a limited set of service profiles. For instance an MCU dedicated to audiographic conferencing does not need a video module; an MCU dedicated to basic videotelephony may have no data module. Another case where the MCU may be simplified is when it is built for an environment in which some of its usual functions are not needed, for instance when some functions are provided by nodes in the network (see A.5).

Note that this functional model applies to a single conference. An MCU is often able to support several independent conferences simultaneously.

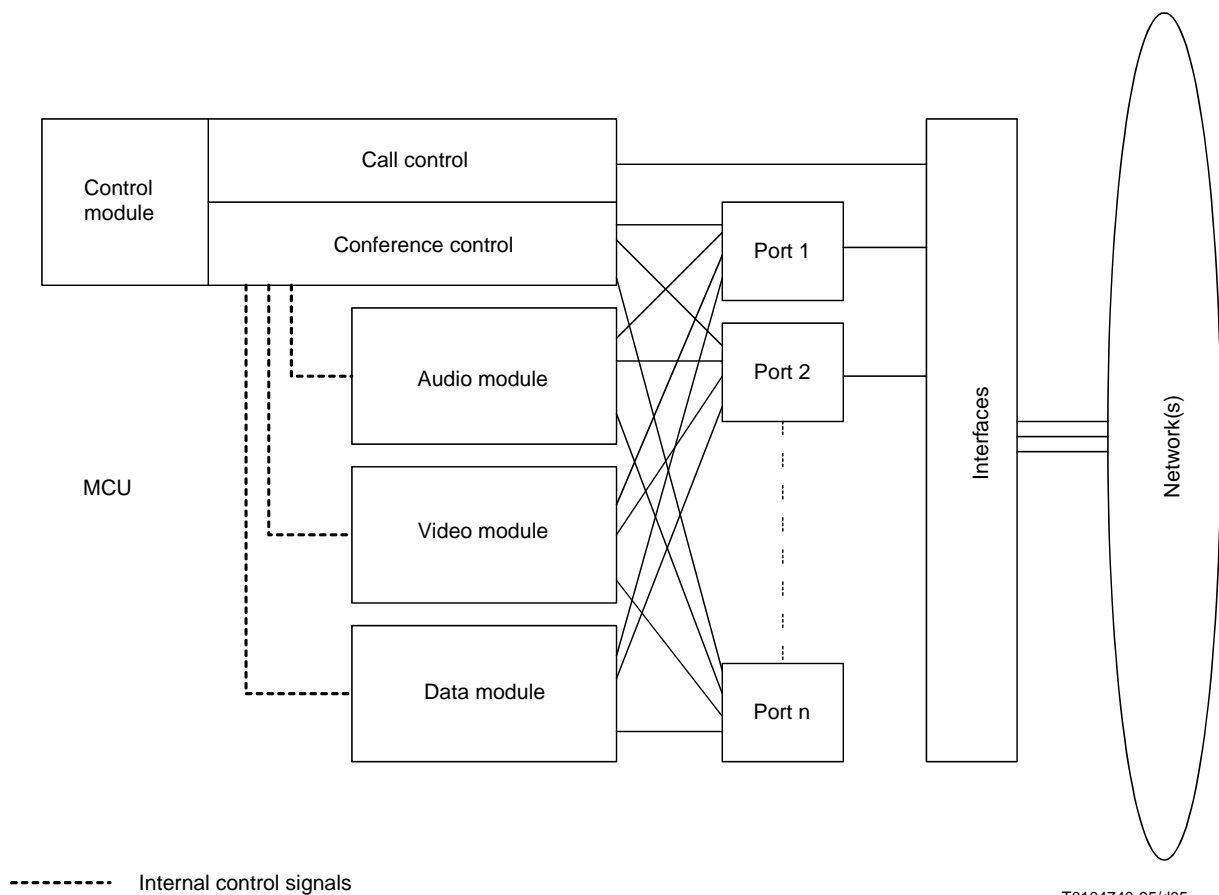

FIGURE A.1/F.702
Functional model of an MCU

A.2 Call control functions

The call control functions vary with the method for call set-up. If the call set-up is only by reservation, then the connections are controlled by the reservation system, and there is no need for the MCU to take any particular action. However, the MCU may exchange information with the reservation system in order to:

- confirm that all connections are correctly established;
- add or drop a terminal;
- change the bit rate of all the connections depending on the capabilities of the terminals and the requests from the call controller;
- reduce the bit rate of a terminal with secondary status;
- split the conference or merge a split conference, if this entails changes in the network resources (e.g. in the case of multiple MCUs);
- request or drop a connection to a server;
- request a prolongation of the conference;
- make a reservation for another conference or request information on already booked future conferences;
- provide or obtain charging information;
- put an end to the conference.

Requests affecting the cost of the call have to be made by the call controller, and the MCU forwards them to the reservation system. The response to requests requiring increased resources is dependent upon the availability of those resources.

In the case of a meet me conference by direct dialling, the situation is similar: no action on the network for call control is required from the MCU; it may however set up, modify or drop connections for the above-mentioned purposes, or call a reservation system concerning future conferences.

In an add-on conference, after the first connection has been set up between the call controller and the MCU, the connections to the other terminals may be established by the call controller and then transferred to the MCU if the network supports this procedure. Alternately the connections may be established by the MCU from a list provided by the call controller. During the course of the conference, the same process may be repeated in order to add other terminals. Other actions for call control are the same as in a meet me conference.

A.3 Conference control functions

Mandatory functions

The mandatory functions are those necessary to support a non-conducted conference, and also the transmission of means for identifying the speaker.

Optional functions

Support of a conducted conference is optional but highly desirable. Other optional control functions are related to the allocation of bandwidth to the various media components, to individual choices by participants of the information they want to receive, to the contents of pictures with multiple windows, to indications on the identities of participants, to security features and to conference splitting.

Description of the control functions

The control functions vary according to the way each of the media components is handled. For instance if in each location the terminal permanently receives all sounds (usually by mixing them), all pictures (e.g. in several windows of a composite picture) and all other information on a common transmission medium, then no control function is mandatory, but optional functions may be offered. In the general case however, selections for audio and/or video have to be made and control functions are required.

The main control functions are described in B.2/F.700, in particular the various control modes (unconducted and conducted) and conference splitting. An example of the control of multiple subpictures is given in Appendix I.

Selection of the transmission mode

Changes in user requirements arising during the course of the call may result in changes in the transmission mode including changes in the connections; then it is part of the call control functions described in A.2. When it only implies reallocation of bit rates inside the existing connections and/or changes in the coding algorithms, then the procedure is simpler because it can be entirely handled within the MCU. Before making the change, the MCU must check whether all terminals can support the requested mode; if this is not the case, then the MCU should notify it and ask for confirmation; the possible choices are: abandon the change, choose another mode compatible with the capabilities of all terminals (or of most of them), relegate some terminals to secondary status or temporarily exclude them from the conference; in those last two cases, all participants should be informed of the new status of the terminals involved (secondary status or temporary exclusion); it is only optional for an MCU to support these status.

Identifications

If the image of the speaker is always transmitted, then no other means for identification is mandatory. In most cases however the MCU will send for identification purposes a number it has arbitrarily allocated to each terminal. In the initiation phase, it may leave it to the participants or to their terminals to exchange information on their identities and locations and to correlate them with these arbitrary numbers; it may also request this information from the various terminals and broadcast them to everyone.

Security features

Security features may include screening of the entrants in the conference, authentication of participants or terminals, encryption of signals and exchange of encryption keys.

Status of the participants

If there are participants with special status (see 6.2.7.5) then this is controlled by the MCU, and it affects the way the signals from these participants are handled.

A.4 Handling the various media components

The MCU handles the various media components as described in B.2.2.2/F.700. This includes:

- mixing and/or switching the audio signals;
- switching and/or combining the video signals;
- distributing the other information types on common data channels and controlling these channels.

A.5 Distributed MCU functions

As stated in 4.3, the term MCU has been used here indifferently for a unique equipment or for a system of distributed and interconnected equipment because they are functionally equivalent. Examples of configurations with single and multiple MCUs are shown in Figure 2. Each terminal is connected to one of the MCUs, and the MCUs exchange the appropriate signals in order to behave as a single entity, except for possible transmission delays and limitations in the available user signals due to the capabilities of the inter-MCU connections.

Other configurations may be set up in networks offering broadcasting, selection and/or non-symmetrical connections. In addition to the three configurations described above, these networks may support configurations in which some functions of the MCUs are distributed in nodes of the network, i.e. points in the network capable of accomplishing functions such as switching, broadcasting, distributing, possibly multiplexing of signals. These nodes may be considered as carrying in a distributed way some simple functions of MCUs. An example of broadcasting and multiplexing in a node is illustrated in Figure A.2: the MCU transmits information to a distant node which broadcasts them to the neighbouring terminals connected to it; it multiplexes the signals received from these terminals on a single channel to the MCU.

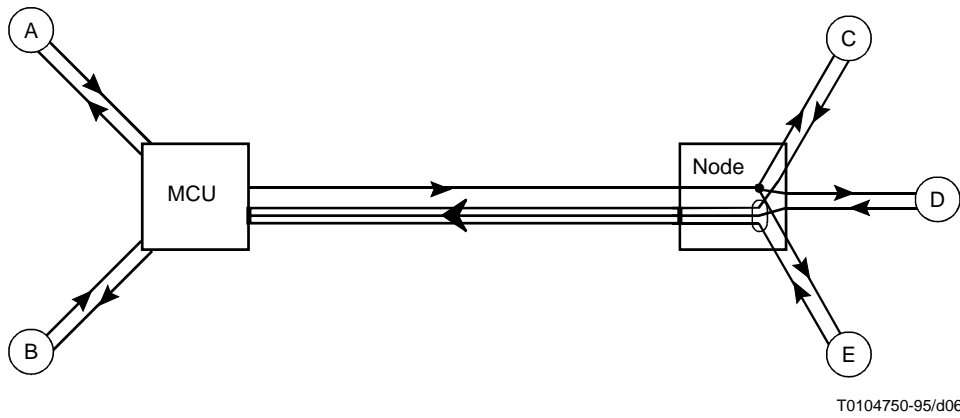

FIGURE A.2/F.702
Broadcasting and multiplexing in a node

Another example of a node is the space segment of a satellite network. The satellite provides the multipoint function by broadcasting the signals it receives to all earth stations (Figure A.3). If each conference site is able to access a satellite earth station providing connection with the space segment, then all signals are available there. An MCU is needed on each site to select or combine the signals for each media component. However, if the terminals are able to handle multiple signals, e.g. by sending the audio signals to several loudspeakers and displaying the pictures on several screens, then a multichannel multipoint configuration is obtained (see 4.3) and MCUs are not required.

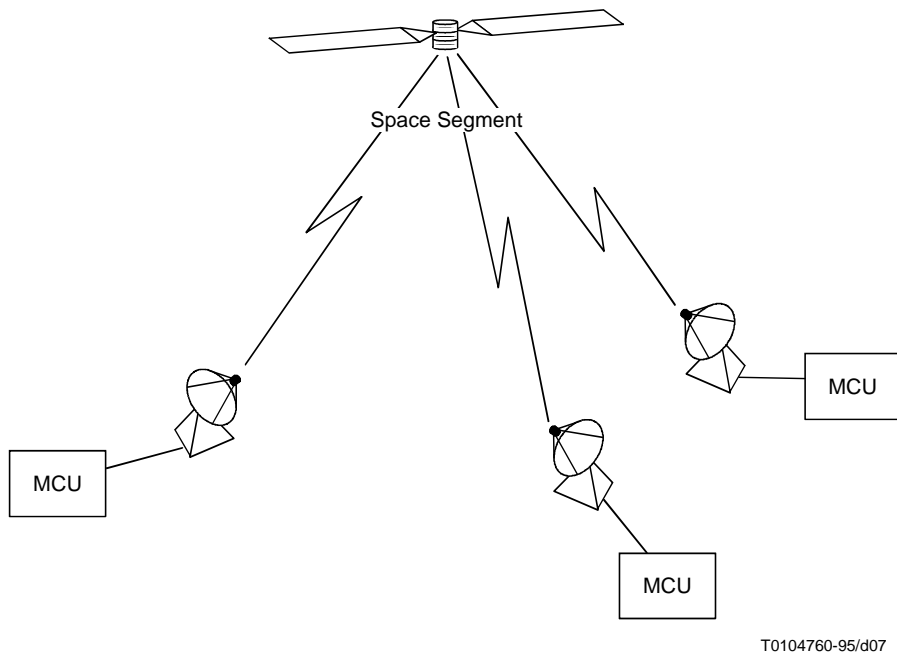

FIGURE A.3/F.702
Multipoint conference around a satellite network

A.6 Ports and interfaces

The interfaces of the MCUs depend upon the network(s) to which they are connected and upon the configuration. An MCU may be connected to several networks. For instance an audiographic conference may be set up with the audio on the PSTN and other media components on a dedicated data network; in such a case each port is connected to two interfaces, one with the PSTN and the other with the data network. Another example of connection to different networks is a private MCU connected to local terminals through a private network and to distant terminals through a public network.

In the first example above, there were two interfaces for each port. Conversely, the physical interfaces to the ISDN are usually primary rate accesses to which several 2 B or 6 B ports to different terminals or MCUs are jointly connected.

A.7 Interworking/intercommunication

The various cases of interworking or intercommunication are presented in clause 8.

Intercommunication between videoconference and videotelephony at the same bit rate is mandatory. It may exclude the data channels if both types of terminals do not have that capability.

The possibility of joining a conference with a telephone terminal should be offered.

All other cases of interworking or intercommunication are optional, in particular the capability of connecting terminals with secondary status and the capability of temporarily excluding a terminal while other terminals use a communication mode that it does not support.

Appendix I

Control of multiple windows

(This appendix does not form an integral part of this Recommendation)

I.1 General

Multiple windows offer many different possibilities and their control may thus be complex to operate. For the pictures broadcast to all terminals, it may therefore be done by the Chairman or left to the controller or to another participant (conference secretary). Some multipoint systems may also allow participants to individually request specific pictures to be sent to them. The commands should be kept as simple as possible and should be assisted by an automatic selection process based on detection of speech and on commands for taking or allocating the floor. A possible set of commands is shown hereafter.

I.2 Starting, stopping and organizing multiple windowing

Commands should allow starting and stopping the multiple windows mode, and defining the number, dimensions and lay-out of the windows, preferably as standard partitions of the screen. This should not prevent implementers to display them on several different screens if they are available in the conference room. The minimum size of a window is dependent on the resolution of the picture. Some windows may be larger than others, but they are supposed to have the same format so that any subpicture may be displayed in any window. A window of a different format, e.g. double width or double height, could also be reserved to a specific terminal capable of generating this format.

I.3 Selection of the windows' contents

Windows may be allocated through specific commands to participants nominally, according to a stable status (Chairman, lecturer, members of a panel, etc.) or to a transient status (present speaker, previous speaker, new entrant, etc.).

It is necessary however to limit the number of changes in the picture composition, and to prevent the various elementary pictures from jumping simultaneously across the screen from one window to another; for instance this would happen each time some participant would take the floor if windows were allocated specifically to the last speakers.

To avoid this, a list is defined, containing by default the latest speakers with priorities increasing in the order of taking the floor. Other participants may be inserted in the list by specific commands. Windows assigned to this list are considered equivalent; elementary pictures are allocated to these windows in the order of priorities; when a new elementary picture has to be displayed, it displaces the one with the lowest priority by taking its window; thus only one window is affected by the change (Figure I.2).

Alternately, a specific window, for instance a window of larger size, may be allocated to the present speaker. Then if a participant already on the screen takes the floor, he will leave his window to the previous speaker and take the specific window (Figure I.2).

If specific windows are also allocated to other participants (e.g. the Chairman or panel members), whose picture will take the larger window while they speak and then return to their original specific window, then three windows at most may be affected at a time (Figure I.3).

Instead of being allocated to a given elementary picture, a window may be used for other purposes such as written announcements, graphics or for the time rotating display of all participants not present on the screen.

A terminal may send a picture composed of several elementary pictures from different sources. This is not allowed while the MCU is itself transmitting composed pictures, because windows inside a window would be too small. However, two or more windows may be allocated to the same terminal if it is able to generate them and send them independently.

Examples of picture composition

Mode 1 - All windows equivalent, some participants P_i have priority for having their pictures displayed, the remaining windows are allocated to the latest speakers S_j (the present or latest non-priority speaker is S_1 , and the priority decreases with increasing rank j).

Each priority participant is allocated a fixed window. Any other speaker is allocated a window when he takes the floor and keeps it until his priority has become the lowest so that he is replaced by a new speaker. Thus only one window may change at a time. Figure I.1 shows that:

- when a priority participant takes the floor, there is no change in the picture composition and the ranks of all non-priority speakers are unchanged;
- when a non-priority speaker already on the screen takes the floor again, there is no change in the picture composition; he becomes S_1 and the ranks of other speakers increase by one unit if smaller than he had; ranks larger than he had are unchanged;
- when a participant not yet on the screen takes the floor, he takes the window of the former speaker with the lowest priority; he becomes S_1 and all non-priority previous speakers have their rank increased by one unit.

Key to Figures I.1 to I.3

Figures I.1 to I.3 show examples of the arrangement of windows on a screen and of the evolution of their contents.

P denotes a participant who has been permanently allocated a specific window. **p** denotes (in Figures I.2 and I.3) a participant who has been allocated a priority for being on the screen, but in any available window. **S** denotes a non-priority participant who is on the screen because he is a previous speaker, but will drop out when his priority becomes too low.

In the Figures, shading indicates a window that has changed, while the darker framing shows the window allocated to the present speaker. When the rank of a speaker **S** has changed, his previous rank is shown in parenthesis. Arrows show pictures moved into a window, or out of a window, or from one window to another.

Mode 2 – A specific window is allocated to the participant who has the floor, while all other windows are considered equivalent.

The pictures selected for display are the same as in mode 1, but they are moved so that the present speaker is always in the preferred window. If he was already on the screen, there is an exchange between the pictures of the present and former speakers; if the new speaker was not already on the screen, then the picture with the lowest priority is dropped and the picture of the former speaker takes its window. Thus two windows are affected by each change of speaker. This process is shown in Figure I.2.

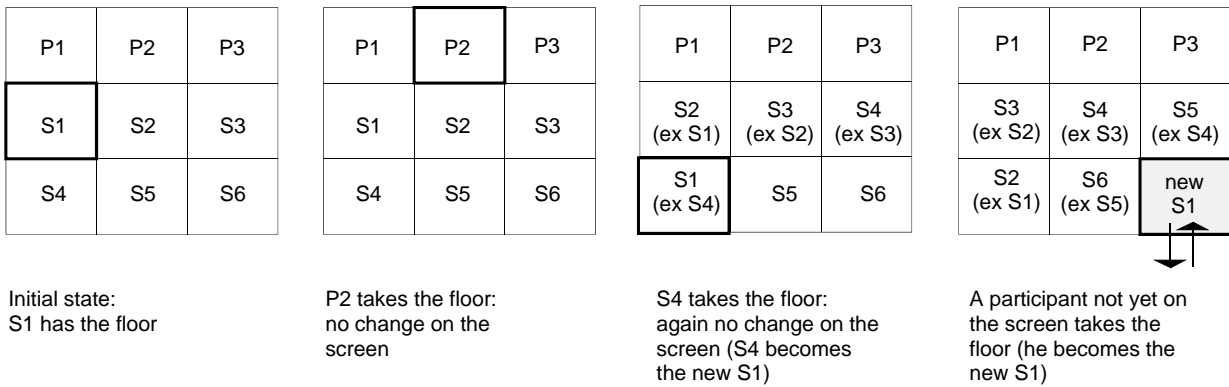

T0105020-96/d08

FIGURE I.1/F.702
All windows equivalent

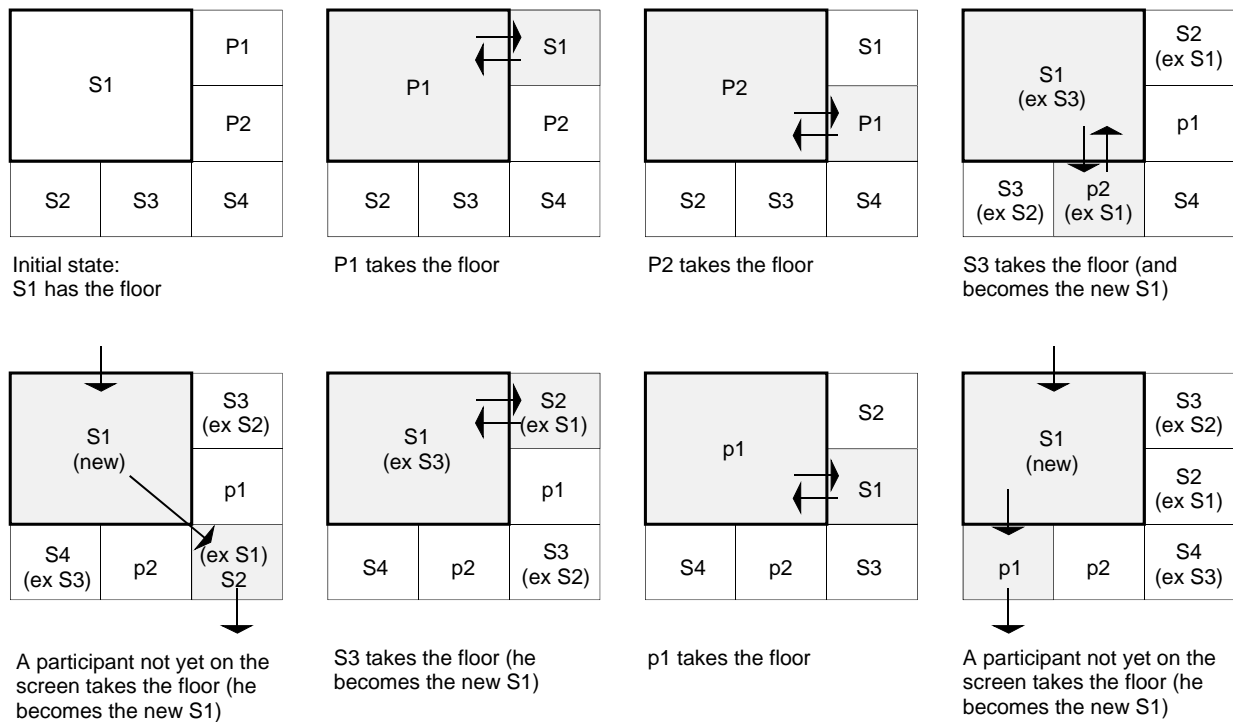

T0105030-96/d09

FIGURE I.2/F.702
A specific window allocated to the participant who has the floor

Mode 3 – Specific windows are allocated to the participant who has the floor and to some other priority participants.

Some of the priority participants, e.g. the Chairman, may be allocated fixed windows (Pi), while others, e.g. panel members, are allocated any window in a set (pk); the latter case decreases slightly the number of windows affected by changes of speakers, because after taking the floor those pictures may return to any free window in the set instead of a specific one.

Again the pictures selected for display are the same as in modes 1 and 2, but the number of windows affected by each change of speaker is now two or three (see Figure I.3).

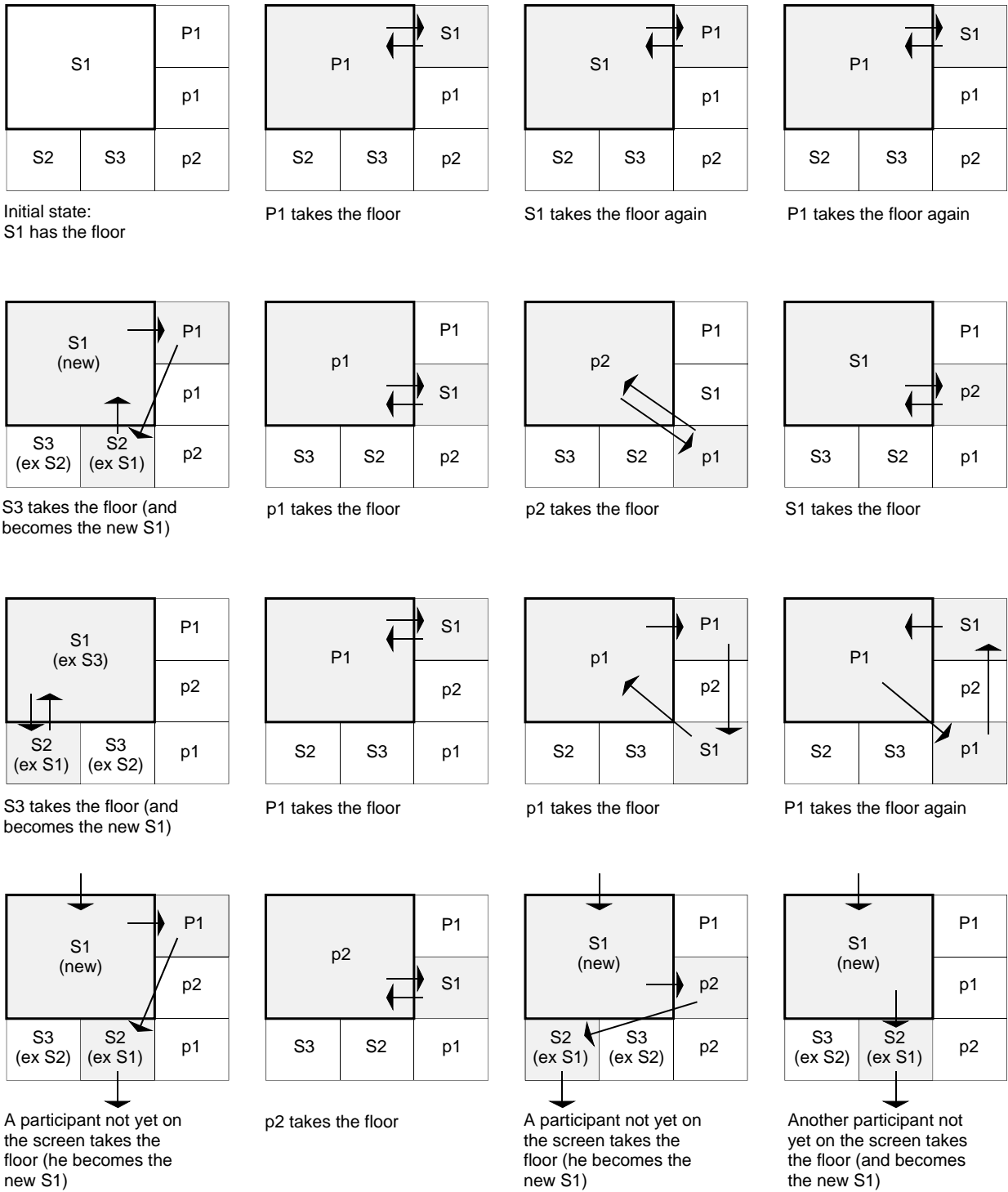

T0105950-96/d10

FIGURE I.3/F.702

Specific windows allocated to some participants and to the one who has the floor

NOTE – A variant of this mode is to allocate windows permanently to the priority participants and, when they take the floor, to display them a second time in the speaker’s window if it is larger; this reduces the number of windows affected by a change of speaker to two only.

ITU-T RECOMMENDATIONS SERIES

- Series A Organization of the work of the ITU-T
- Series B Means of expression
- Series C General telecommunication statistics
- Series D General tariff principles
- Series E Telephone network and ISDN
- Series F Non-telephone telecommunication services**
- Series G Transmission systems and media
- Series H Transmission of non-telephone signals
- Series I Integrated services digital network
- Series J Transmission of sound-programme and television signals
- Series K Protection against interference
- Series L Construction, installation and protection of cables and other elements of outside plant
- Series M Maintenance: international transmission systems, telephone circuits, telegraphy, facsimile and leased circuits
- Series N Maintenance: international sound-programme and television transmission circuits
- Series O Specifications of measuring equipment
- Series P Telephone transmission quality
- Series Q Switching and signalling
- Series R Telegraph transmission
- Series S Telegraph services terminal equipment
- Series T Terminal equipments and protocols for telematic services
- Series U Telegraph switching
- Series V Data communication over the telephone network
- Series X Data networks and open system communication
- Series Z Programming languages