



INTERNATIONAL TELECOMMUNICATION UNION

ITU-T

TELECOMMUNICATION
STANDARDIZATION SECTOR
OF ITU

E.735

(05/97)

SERIES E: OVERALL NETWORK OPERATION,
TELEPHONE SERVICE, SERVICE OPERATION AND
HUMAN FACTORS

Quality of service, network management and traffic
engineering – Traffic engineering – ISDN traffic
engineering

**Framework for traffic control and
dimensioning in B-ISDN**

ITU-T Recommendation E.735

(Previously CCITT Recommendation)

ITU-T E-SERIES RECOMMENDATIONS

OVERALL NETWORK OPERATION, TELEPHONE SERVICE, SERVICE OPERATION AND HUMAN FACTORS

OPERATION, NUMBERING, ROUTING AND MOBILE SERVICES

INTERNATIONAL OPERATION	E.100–E.229
OPERATIONAL PROVISIONS RELATING TO CHARGING AND ACCOUNTING IN THE INTERNATIONAL TELEPHONE SERVICE	E.230–E.299
UTILIZATION OF THE INTERNATIONAL TELEPHONE NETWORK FOR NON-TELEPHONY APPLICATIONS	E.300–E.329
ISDN PROVISIONS CONCERNING USERS	E.330–E.399

QUALITY OF SERVICE, NETWORK MANAGEMENT AND TRAFFIC ENGINEERING

NETWORK MANAGEMENT	E.400–E.489
TRAFFIC ENGINEERING	E.490–E.799
Measurement and recording of traffic	E.490–E.505
Forecasting of traffic	E.506–E.509
Determination of the number of circuits in manual operation	E.510–E.519
Determination of the number of circuits in automatic and semi-automatic operation	E.520–E.539
Grade of service	E.540–E.599
Definitions	E.600–E.699

ISDN traffic engineering **E.700–E.749**

Mobile network traffic engineering	E.750–E.799
QUALITY OF TELECOMMUNICATION SERVICES: CONCEPTS, MODELS, OBJECTIVES AND DEPENDABILITY PLANNING	E.800–E.899
Terms and definitions related to the quality of telecommunication services	E.800–E.809
Models for telecommunication services	E.810–E.844
Objectives for quality of service and related concepts of telecommunication services	E.845–E.859
Use of quality of service objectives for planning of telecommunication networks	E.860–E.879
Field data collection and evaluation on the performance of equipment, networks and services	E.880–E.899

For further details, please refer to ITU-T List of Recommendations.

ITU-T RECOMMENDATION E.735

FRAMEWORK FOR TRAFFIC CONTROL AND DIMENSIONING IN B-ISDN

Summary

This Recommendation provides a framework for traffic control and dimensioning in B-ISDN. This Recommendation gives an overview of the traffic engineering tasks required for configuring the network; it describes the network aspects that are relevant for traffic engineering; it defines the network resources to be considered and explains the relation between cell-level traffic controls (described in Recommendation E.736) and call-level traffic controls and dimensioning (described in Recommendation E.737). Finally this Recommendation gives guidelines on strategies for configuration of network VPCs.

Source

ITU-T Recommendation E.735 was prepared by ITU-T Study Group 2 (1997-2000) and was approved under the WTSC Resolution No. 1 procedure on the 26th of May 1997.

FOREWORD

ITU (International Telecommunication Union) is the United Nations Specialized Agency in the field of telecommunications. The ITU Telecommunication Standardization Sector (ITU-T) is a permanent organ of the ITU. The ITU-T is responsible for studying technical, operating and tariff questions and issuing Recommendations on them with a view to standardizing telecommunications on a worldwide basis.

The World Telecommunication Standardization Conference (WTSC), which meets every four years, establishes the topics for study by the ITU-T Study Groups which, in their turn, produce Recommendations on these topics.

The approval of Recommendations by the Members of the ITU-T is covered by the procedure laid down in WTSC Resolution No. 1.

In some areas of information technology which fall within ITU-T's purview, the necessary standards are prepared on a collaborative basis with ISO and IEC.

NOTE

In this Recommendation, the expression "Administration" is used for conciseness to indicate both a telecommunication administration and a recognized operating agency.

INTELLECTUAL PROPERTY RIGHTS

The ITU draws attention to the possibility that the practice or implementation of this Recommendation may involve the use of a claimed Intellectual Property Right. The ITU takes no position concerning the evidence, validity or applicability of claimed Intellectual Property Rights, whether asserted by ITU members or others outside of the Recommendation development process.

As of the date of approval of this Recommendation, the ITU had/had not received notice of intellectual property, protected by patents, which may be required to implement this Recommendation. However, implementors are cautioned that this may not represent the latest information and are therefore strongly urged to consult the TSB patent database.

© ITU 1997

All rights reserved. No part of this publication may be reproduced or utilized in any form or by any means, electronic or mechanical, including photocopying and microfilm, without permission in writing from the ITU.

CONTENTS

	<i>Page</i>
1	Scope of this Recommendation..... 1
2	References 1
3	Terms and definitions..... 1
4	Abbreviations 2
5	Introduction 3
6	General considerations on B-ISDN networks 3
6.1	Layers and levels in the network 3
6.2	Connection types 5
6.3	Nodes 6
6.4	Types of networks 8
6.5	ATM transfer capabilities 10
6.6	QOS requirements 10
6.7	GOS objectives 10
6.8	Traffic controls 11
7	Resources in the ATM layer: definitions and implications 12
7.1	ATM link 12
7.2	VPC as a connection and as a resource..... 14
7.3	Characterization of network-to-network VPCs 15
7.4	ATM link set and VPC set..... 18
8	Relation between cell-level traffic control and dimensioning..... 19
8.1	Iterative approach 19
8.2	Equivalent cell rate 20
9	Strategies for network configuration..... 21
9.1	Applications of VPCs 21
9.2	Drawbacks of the use of VPCs 22
9.3	Requirements and guidelines 23
10	History..... 25

FRAMEWORK FOR TRAFFIC CONTROL AND DIMENSIONING IN B-ISDN

(Geneva, 1997)

1 Scope of this Recommendation

This Recommendation establishes the framework for traffic control and dimensioning in B-ISDN. These methods are required to allocate and control resources in the B-ISDN in order to carry the offered traffic (modelled in the E.710 Series of Recommendations) while meeting the GOS objectives (to be defined in the E.720-Series of Recommendations). This Recommendation introduces the subject, describes the network aspects that are relevant for traffic engineering, states the relation between the cell-level traffic controls (described in Recommendation E.736) and call-level traffic controls and dimensioning (described in Recommendation E.737), and gives guidelines on strategies for network configurations using the VP concept. In this present issue, only the user plane is considered.

2 References

The following ITU-T Recommendations and other references contain provisions which, through reference in this text, constitute provisions of this Recommendation. At the time of publication, the editions indicated were valid. All Recommendations and other references are subject to revision; all users of this Recommendation are therefore encouraged to investigate the possibility of applying the most recent edition of the Recommendations and other references listed below. A list of the currently valid ITU-T Recommendations is regularly published.

- ITU-T Recommendation E.716 (1996), *User demand modelling in Broadband ISDN*.
- ITU-T Recommendation E.736 (1997), *Methods for cell-level traffic control in B-ISDN*.
- ITU-T Recommendation E.737 (1997), *Dimensioning methods for B-ISDN*.
- ITU-T Recommendation I.311 (1996), *B-ISDN general network aspects*.
- ITU-T Recommendation I.356 (1996), *B-ISDN ATM layer cell transfer performance*.
- ITU-T Recommendation I.371 (1996), *Traffic control and congestion control in B-ISDN*.

3 Terms and definitions

This Recommendation defines the following terms.

3.1 ATM node: Generic term used to designate an ATM cross-connect or an ATM switch. The term VP (or VC or VP-VC) node designates either a VP (or VC or VP-VC) cross-connect or a VP (or VC or VP-VC) switch.

3.2 ATM link: Transmission path together with its associated buffer in the upstream node.

3.3 ATM link set: Set of all the ATM links with the same direction of transmission interconnecting two ATM nodes without any intermediate ATM node.

3.4 VPC set: Set of all the VPCs with the same direction of transmission interconnecting two VC nodes without any intermediate VC node.

3.5 DBR VPC: VPC characterized by a Peak Cell Rate (PCR) and a Cell Delay Variation Tolerance (CDVT).

3.6 uncontrolled constant rate VPC: Network-to-network or network-to-user VPC characterized by a rate and a negligible CDV with respect to a reference arrival process.

3.7 variable rate VPC: Network-to-network or network-to-user VPC characterized by cell traffic variables chosen to allow statistical multiplexing of the VCCs in the VPC with other connections on the ATM links traversed by the VPC. This Recommendation defines only one type of variable rate VPC, and it is characterized by its ECR in each of the ATM links.

3.8 equivalent cell rate: A cell rate attributed to a connection such that cell-level GOS objectives are satisfied on an ATM link or network VPC as long as the sum of equivalent cell rates is not greater than the rate of the ATM link or VPC.

4 Abbreviations

This Recommendation uses the following abbreviations.

ABR	Available Bit Rate
ABT	ATM Block Transfer
ATM	Asynchronous Transfer Mode
B-ISDN	Broadband Integrated Services Digital Network
CAC	Connection Admission Control
CDV	Cell Delay Variation
CDVT	CDV Tolerance
CLP	Cell Loss Priority
CLR	Cell Loss Ratio
CPE	Customer Premises Equipment
CTD	Cell Transfer Delay
DBR	Deterministic Bit Rate
DCC	Digital Cross-Connect
ECBP	End-to-end Connection Blocking Probability
ECR	Equivalent Cell Rate
GCRA	Generic Cell Rate Algorithm
GOS	Grade of Service
IBT	Intrinsic Burst Tolerance
NPC	Network Parameter Control
OAM	Operation and Maintenance
PCR	Peak Cell Rate
PDH	Plesiochronous Digital Hierarchy
QOS	Quality of Service
SBR	Statistical Bit Rate
SCR	Sustainable Cell Rate
SDH	Synchronous Digital Hierarchy
STD	Source Traffic Descriptor
TP	Transmission Path

UNI	User-Network Interface
UPC	Usage Parameter Control
VC	Virtual Channel
VCC	VC Connection
VCI	VC Identifier
VP	Virtual Path
VPC	VP Connection
VPI	VP Identifier

5 Introduction

To solve the problem of resource allocation and control implies providing answers to several questions related with the implementation of the network. These questions affect decisions to be taken at different time scales and will be treated in different B-ISDN Recommendations of the E.730- and E.740-Series. They may be enumerated as follows:

- First, a **network topology** must be defined. This largely depends on the operator's policy and is out of the scope of the E.730- and E.740-Series of Recommendations.
- For a given traffic and a given network topology, the operator may want to define network-to-network virtual paths in order to carry user-to-user VC connections with appreciable gains in terms of control costs, easier network reconfigurations and possible subnetwork segregation. Guidelines for this **VP configuration** are given in this Recommendation. This question provides input for VP dimensioning.
- **Network dimensioning** involves the dimensioning of the physical network elements, particularly ATM link sets (including bandwidth and buffer dimensioning), and will be considered in Recommendation E.737.
- **VP dimensioning** relates to the dimensioning of the network-to-network virtual paths defined by the operator, and is considered in Recommendation E.737. The objective is to determine the number of network-to-network virtual paths in the VP configuration and to assign capacity parameters to them.
- **Call-level traffic controls** must be specified in order to guarantee the required call-level GOS objectives. This involves defining the routing, service protection mechanisms and network management. Recommendation E.737 deals with the aspects of these controls more related with dimensioning, namely service protection mechanisms and some aspects of routing. Network management controls are out of scope of the E.730- and E.740-Series of Recommendations.
- **Cell-level traffic controls** must be specified in order for the network to provide the required cell-level GOS objectives and minimize the resources needed for that target. The definition of these traffic controls provides input for VP dimensioning and network dimensioning, because it gives information on the amount of resources needed by a connection to satisfy the cell-level GOS objectives. This problem is treated in Recommendation E.736.

6 General considerations on B-ISDN networks

In B-ISDNs some functionalities, entities and architectural principles are distinctive of these networks and must be taken into account in engineering. These topics are examined in this clause from the viewpoint of their relations with traffic engineering.

6.1 Layers and levels in the network

As stated in Recommendation I.311, the ATM transport network is structured in two layers, namely the physical layer and the ATM layer. For traffic engineering, the upper level of the physical layer, the Transmission Path (TP) level, and the two levels of the ATM layer, the Virtual Path (VP) level and the Virtual Channel (VC) level, are significant (see Figure 6-1).

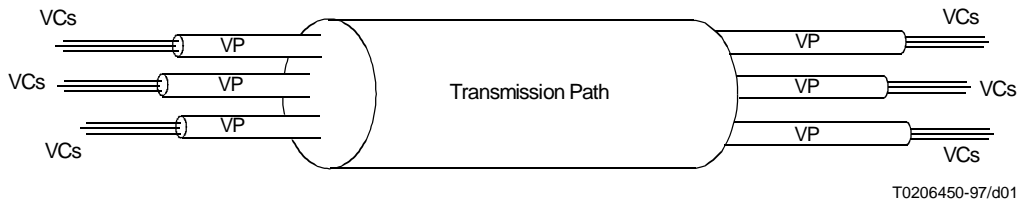

Figure 6-1/E.735 – VP and VC levels in the ATM layer

A Virtual Channel Connection (VCC) is formed as a concatenation of VC links, each VC link being established on a Virtual Path Connection (VPC). Thus a VCC is established on a concatenation of VPCs. In its turn, a VPC is formed as a concatenation of VP links, each VP link being established on a TP. Thus a VPC is established on a concatenation of TPs (see Figure 6-2).

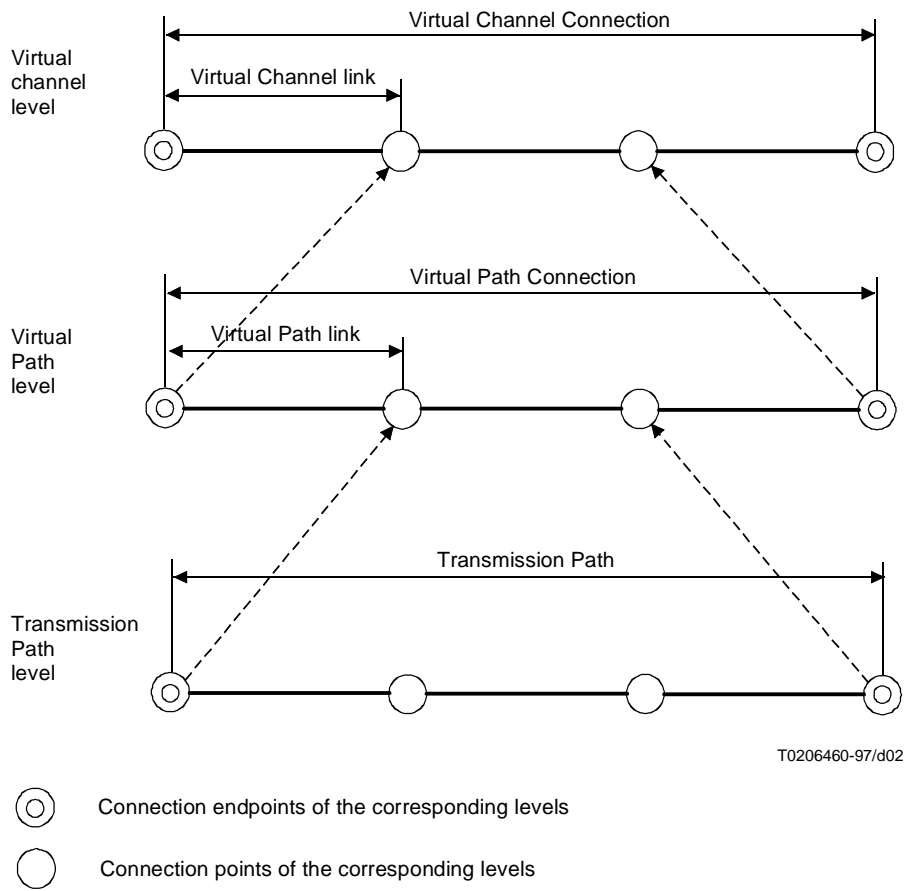

Figure 6-2/E.735 – Hierarchical level to level relationship

Two important particular cases should be considered:

- **A VPC established between two users:** The VCCs established on these VPCs (which are VCCs with only one VC link) are not viewed by the network but only by the users. Thus, from a network point of view, only the TP level and the VP level, but not the VC level, are relevant.

- **A VPC with only one VP link, thus established on only one TP:** The VC links established on this VPC are established on only one TP. Then, from a traffic engineering point of view, one option is to consider that the VC links are directly established on the TP. With this option, although the three levels, TP, VP and VC, formally exist (and the text throughout this clause will follow this formal approach), the VP level is not relevant for traffic engineering. The implications of choosing this option or, alternatively, to consider the three levels as relevant for traffic engineering are explained in 7.1 and 7.2.

A VP link must be within a single TP, and thus cannot be split over multiple TPs.

The TPs are based on the current transmission systems, such as PDH and SDH. The network resources allocated to a TP must be determined among a limited set of possibilities (e.g. 6.3 Mbit/s, 34 Mbit/s and 45 Mbit/s for the PDH; 156 Mbit/s and 622 Mbit/s for the SDH). These limitations, combined with the restriction of not having any VP link split over more than one TP, have to be taken into account in the dimensioning of the network and in the configuration and dimensioning of the VPCs.

6.2 Connection types

Recommendation I.311 defines the possible applications of ATM connections. Each of these applications defines a connection type that is characterized by the location of the connection endpoints (user or network) and by the hierarchical level of the connection within the ATM layer (VP or VC). Thus, following Recommendation I.311 user-user, user-network and network-network VCCs and VPCs exist.

In the E.700-Series of Recommendations, however, the direction of the cell traffic flow in a connection which has one endpoint at a user's premises and the other within the network is important since different resource allocation schemes apply. Thus, for the purpose of the E.700-Series of Recommendations, eight different types of connections exist:

- a) user-to-user VCC;
- b) user-to-user VPC;
- c) network-to-network VCC;
- d) network-to-network VPC;
- e) user-to-network VCC;
- f) user-to-network VPC;
- g) network-to-user VCC;
- h) network-to-user VPC.

Note that in Recommendation I.311, both user-to-network and network-to-user connections are termed user-network connections.

User-to-user VCCs and user-to-user VPCs are established upon user request, to provide a cell transport capability between T_B or S_B reference points.

Network-to-network VCCs and network-to-network VPCs, on the contrary, are established as a result of a decision taken by the network operators. Usage of network-to-network VPCs allows for the operation and control of a bundle of VCCs as a whole. The implications of this type of connection for traffic engineering are that resources may be managed and allocated as an aggregate, instead of individually on a per user connection basis. The definition of the network-to-network VPCs to be established is an important part of the configuration of the network. Applications of network-to-network VPCs are described in 9.1.

Usage of connections of types e), f), g) and h) is rather specific (it is currently limited to the UNI, some access configurations, OAM and signalling applications).

From a traffic engineering point of view, the panorama of connection types may be simplified since:

- The considerations on VCCs normally apply to all four types [types a), c), e) and g)].
- Most considerations applicable to user-to-user VPCs are also applicable to user-to-network VPCs.

- Most considerations applicable to network-to-network VPCs are also applicable to network-to-user VPCs.

Thus, to enhance the readability of this Recommendation, the text hereinafter will not normally contain references to user-to-network and network-to-user VPCs since, according to the above paragraph, the considerations applicable for them can be easily derived.

6.3 Nodes

There are three different types of nodes¹ in the ATM network:

- **VP nodes:** They switch VPCs between different TPs (see Figure 6-3). A TP leaving a VP node² carries VPCs which do not start in this node. The VP node cannot view the VCCs carried on these VPCs. Thus, it cannot decide on the acceptance of VCCs nor provide different priorities to VCCs of the same VPC. However it has to decide on the acceptance of VPCs and may provide different priorities to different VPCs.

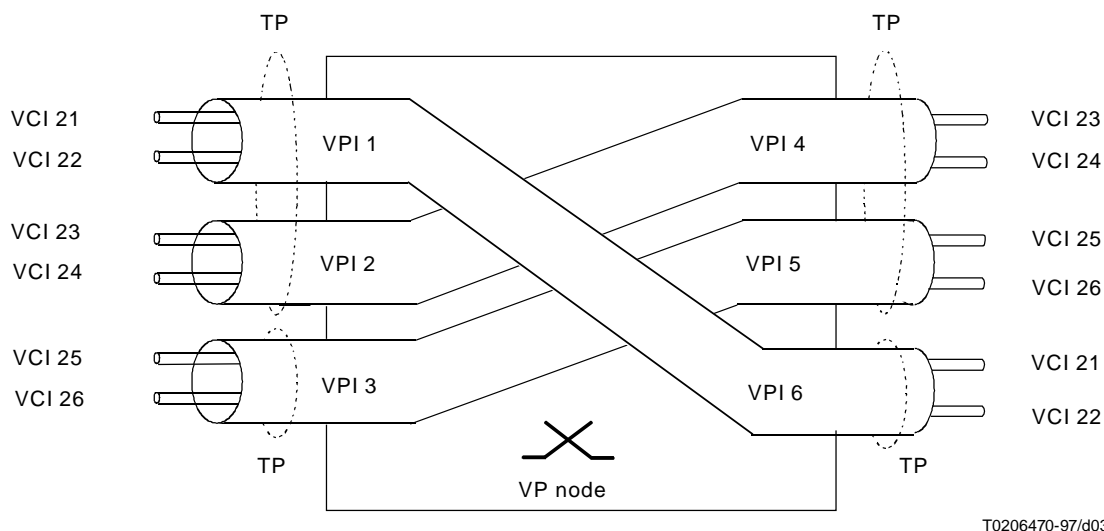

Figure 6-3/E.735 – Representation of a VP node

- **VC nodes:** They switch VCCs between different VPCs (see Figure 6-4). A TP leaving a VC node carries VPCs which start in this node. The VC node views the VCCs carried on these VPCs. It has to decide on the acceptance of VCCs and VPCs. A VC node may provide different priorities to VCCs of the same or of different VPCs.
- **VP-VC nodes:** A VP-VC node acts both as a VP node and as a VC node (see Figure 6-5). A TP leaving a VP-VC node may carry both VPCs starting and not starting in this node. The VP-VC node views the VCCs carried on the VPCs starting in the node, but it cannot view the VCCs of the VPCs not starting in the node. Thus the VP-VC node behaves as a VC node for the VPCs starting in the node, and as a VP node for the VPCs not starting in the node.

¹ An ATM node may be a switch, when directed by control plane functions, or a cross-connect, when directed by management plane functions. As in this Recommendation only user plane is considered, no distinctions are normally made between switches and cross-connects.

² The term leaving or arriving at a node refers to the direction of the cell flow, not to the direction of the establishment of the connections. The text emphasizes the TPs that leave the node since the node may provide priority control and may decide on acceptance of connections on these TPs, but not on the arriving TPs; the control of the latter ones is done in their upstream nodes.

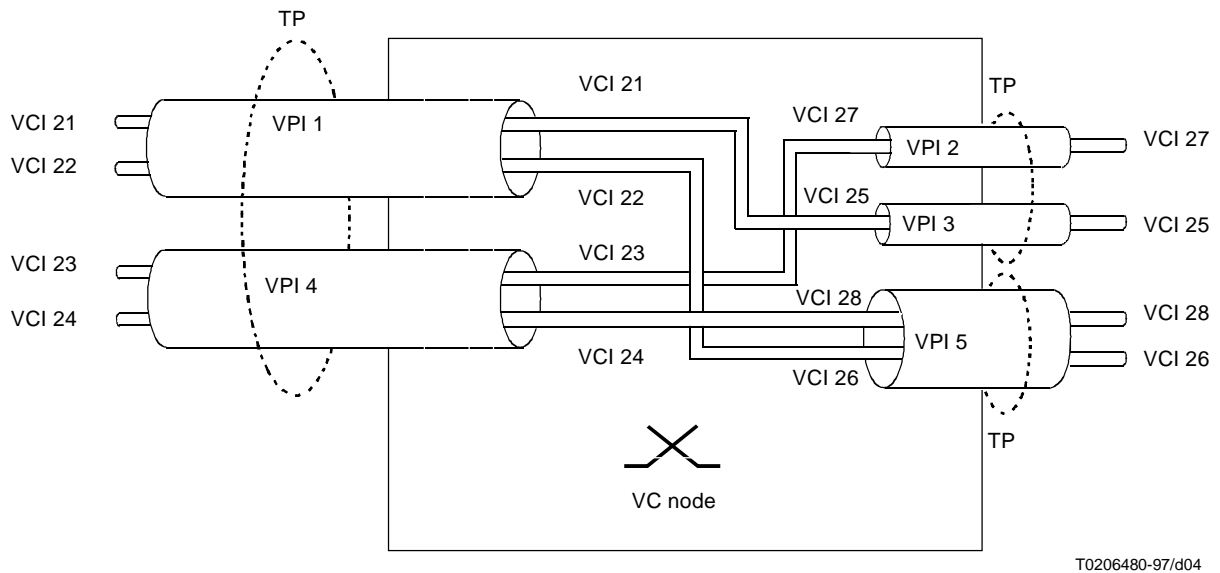

Figure 6-4/E.735 – Representation of a VC node

In the following, the term VC node will normally be used to indicate a VC node or the VC part of a VP-VC node, and analogous use will be made of the term VP node.

Figure 6-6 shows how the communication between nodes is done in the network.

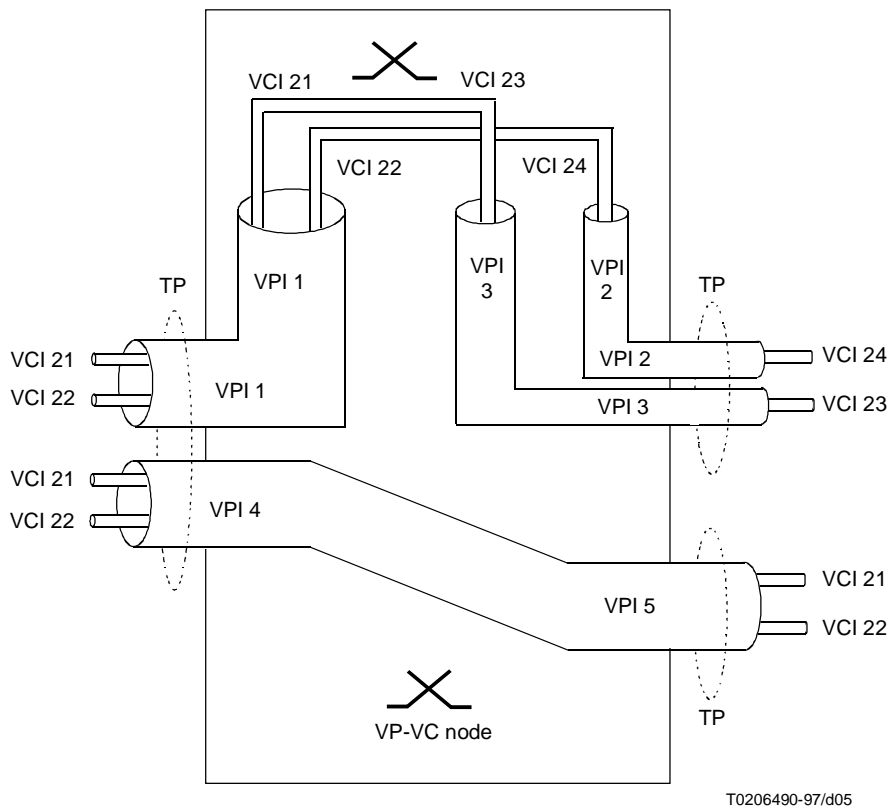

Figure 6-5/E.735 – Representation of a VP-VC node

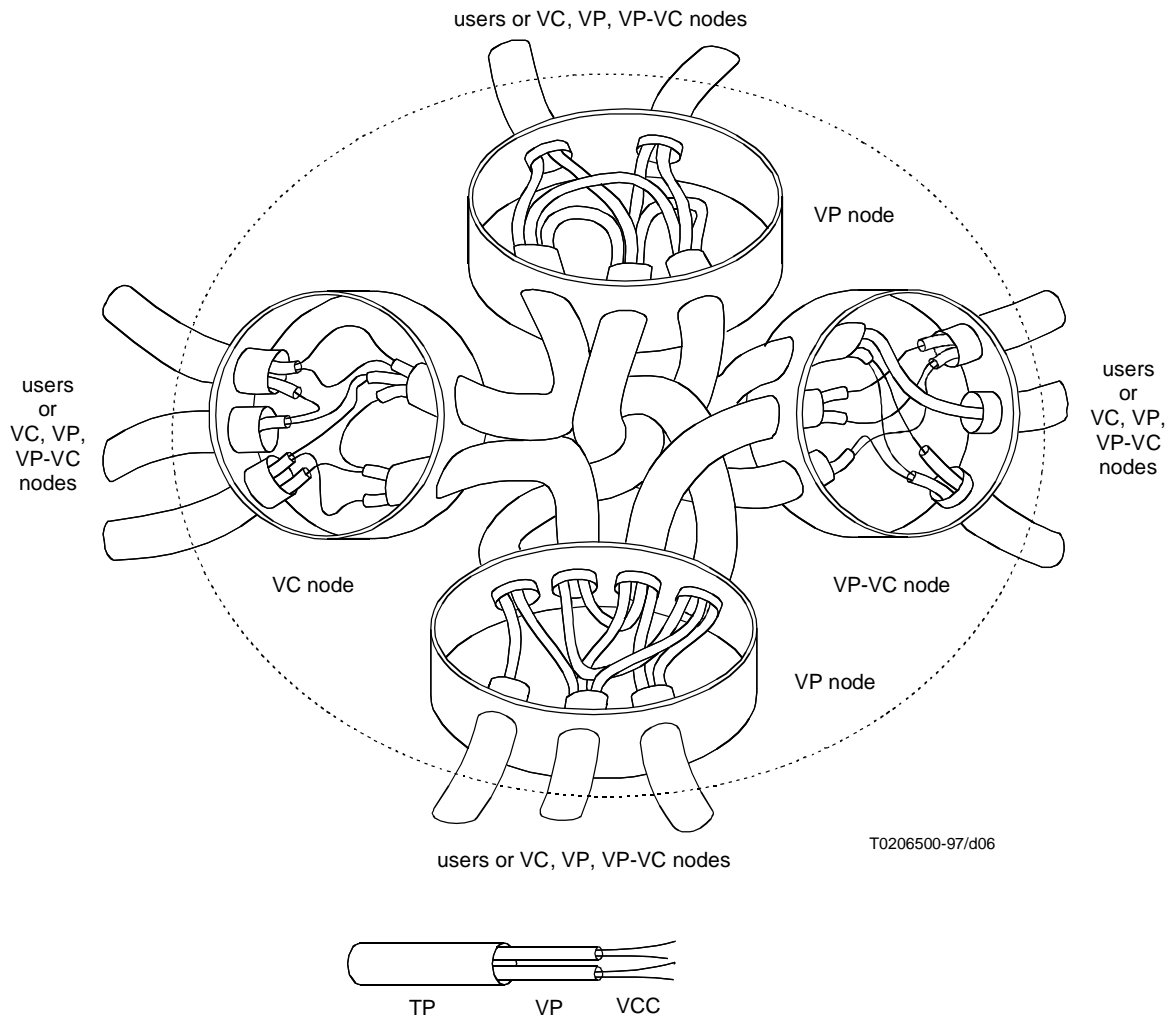

Figure 6-6/E.735 – An example of communication between nodes

6.4 Types of networks

Two basic types of networks may be identified:

- *Specialized networks*
 - VPC-based bearer service network: The only user connections it has are user-to-user VPCs. Nodes in this network are all VP nodes. The routing of user-to-user VPCs in this network is made by selecting in each VP node a TP which connects it to the next VP node to be used in the connection.
 - VCC-based bearer service network: The only user connections it has are user-to-user VCCs. Nodes in this network may be VP, VC and VP-VC nodes, but only VC nodes and the VC part of the VP-VC nodes are considered nodes of the VCC-based bearer service network, since VP nodes can be considered in this network as playing a lower level role. In this network, network-to-network VPCs are pre-established to interconnect VC nodes (directly or through VP nodes), and user-to-network and network-to-user VPCs are pre-established to interconnect users with their local VC nodes. The routing of a user-to-user VCC is made (see Recommendation E.177) by selecting in each VC node a VPC which connects it to the next VC node to be used in the connection.
- *Integrated networks*

They may include both user-to-user VCCs and user-to-user VPCs. The nodes may be VP nodes, VC nodes or VP-VC nodes.

A network with user-to-user VCCs and user-to-user VPCs may be operated as one integrated network or as two overlay networks: one VCC-based bearer service network and one VPC-based bearer service network (see Figure 6-7).

Different overlay networks may also be considered when it is desired to allocate resources separately; for example, for segregating portions of the network that support different transfer capabilities.

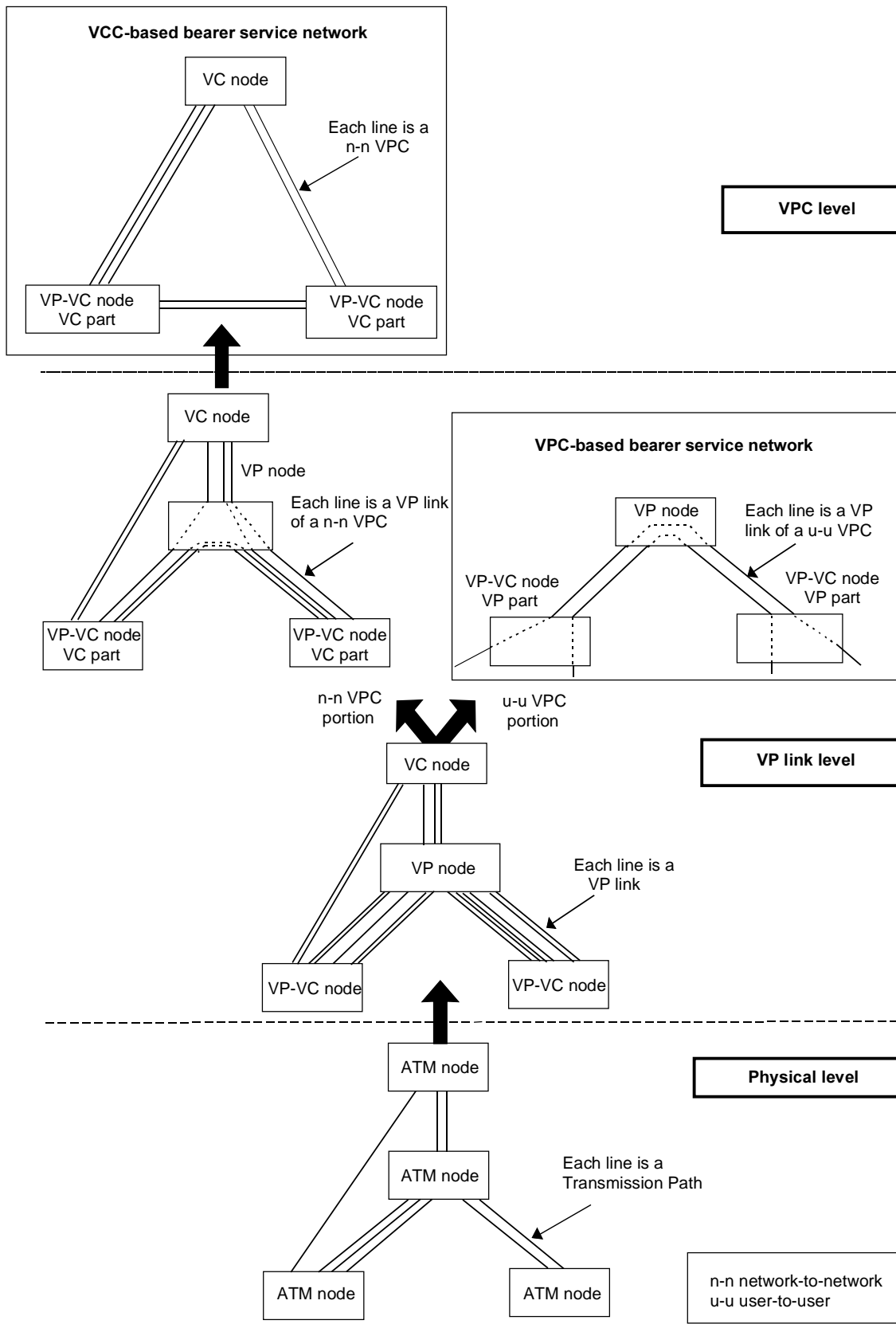

T0206510-97/d07

Figure 6-7/E.735 – A network with user-to-user VPCs and user-to-user VCCs seen as two overlay networks

6.5 ATM transfer capabilities

Recommendation I.371 defines a limited set of ATM transfer capabilities: An ATM transfer capability is intended to support an ATM layer service model and associated QOS through a set of ATM layer traffic parameters and procedures. The use of transfer capabilities has both a user's perspective, wherein a transfer capability is seen as suitable for a given set of applications, and a network operator's perspective wherein a transfer capability may provide gain through statistical multiplexing. Transfer capabilities currently specified are Deterministic Bit Rate (DBR), Statistical Bit Rate (SBR), Available Bit Rate (ABR) and ATM Block Transfer (ABT).

Each ATM connection has an explicitly or implicitly declared ATM transfer capability. It must, however, be emphasized that the traffic parameters and network performance objectives used by the network operator for a connection do not have to be coincident but only compatible with the ATM traffic parameters and QOS commitments of the ATM transfer capability. For example, a network operator could assign the same network performance objectives – those derived from the most stringent QOS requirements – to all of the connections. This fact is particularly relevant for network-to-network VPCs. VCCs supporting different transfer capabilities can be carried through the same network-to-network VPC, and the traffic parameters and network performance objectives defined for the VPC do not have to be coincident with those of any transfer capability.

6.6 QOS requirements

QOS requirements of the B-ISDN users may vary substantially from one user to another. A network operator may achieve higher resource utilization by providing different treatment to transfer capabilities with different QOS requirements.

Two types of QOS requirements must be considered:

- **Call-and connection-level QOS requirements:** These requirements are related with the call or connection set-up/modification/release phases and are related to delays and blocking probabilities of call or connection set-up/modification/release requests. The relevant requirements for traffic engineering in the user plane are those related with the blocking probabilities, notably the End-to-end Connection Blocking Probability (ECBP). ECBP applies to both blocking of connection set-up requests and of connection renegotiation requests.
- **Cell-level QOS requirements:** These requirements are related with the information transfer phase and hence are applicable to connections that are already established through the network. These requirements are defined as required values for the cell-level performance parameters defined in Recommendation I.356. More specifically the parameters relevant for traffic engineering are Cell Loss Ratio (CLR), Cell Transfer Delay (CTD) and Cell Delay Variation (CDV).

Even though user QOS requirements may vary over a continuous spectrum of values, a network will only handle a restricted set of QOS classes.

Corresponding to the above two types of QOS requirements are two types of QOS classes:

- **Call- and connection-level QOS classes:** Each class is characterized by a target value for ECBP.
- **Cell-level QOS classes:** Each class is characterized by a set of objective values for CLR, CTD and CDV.

6.7 GOS objectives

From the QOS requirements the end-to-end network performance objectives of the connections are derived. However it must be taken into account that the network can provide different treatment to the different QOS classes, but it also may occur that a network provides the same treatment to all or to several QOS classes. In the latter case, the most stringent requirement for each QOS parameter must be provided for all the connections which receive the same treatment.

An important consequence of these two possibilities is that the end-to-end network performance objectives are not only derived from the QOS requirements but also from the network operator strategy.

Among the network performance objectives, the Recommendations of the E.700-Series will focus on those related to traffic engineering, that is, on the Grade of Service (GOS) objectives. As well as for QOS requirements, two levels of GOS objectives can be distinguished:

- **Call- and connection-level GOS objectives:** The relevant end-to-end parameter for traffic engineering of the user plane is, according to 6.6, the End-to-end Connection Blocking Probability (ECBP).
- **Cell-level GOS objectives:** The relevant end-to-end cell-level GOS objectives are the maximum queueing delay (defined as a remote quantile of the delay distribution), the mean queueing delay (both based on the QOS parameters CTD and CDV) and the CLR.

From the end-to-end GOS objectives, a partition on the basis of defined reference connections yields the GOS objectives for each network stage. This partition also depends on the network operator strategy. For example, an operator can decide that a network stage provides the same treatment to two connections with different end-to-end CLR objectives. The portion of the end-to-end CLR allocated to this network stage would be the same for both connections, but the total end-to-end CLR objective can be different if the CLR allocated to other network stages is different for the two connections. The only condition to be satisfied is that the sum of the CLR objectives allocated to each network stage for each connection does not exceed its corresponding end-to-end objective. The partitioning can be made as follows:

- For call- and connection-level objectives, from the ECBP target values, taking into account the routing strategy, connection blocking probabilities may be apportioned to each VPC set and to each ATM link set, as explained in 7.4. How and to what extent apportionment of ECBP values is done, given dynamic routing strategies, is for further studies.
- For cell-level objectives:
 - From the end-to-end target values for VCCs, target values are apportioned to each VPC through which the VCCs are carried. The limitations mentioned in 7.1.1 on the target values assigned to different VCCs carried on the same VPC have to be taken into account.
 - From the end-to-end target values for VPCs (in case of network-to-network VPCs, their end-to-end target values are the values apportioned in the partitioning of the end-to-end target values of the VCCs), target values are apportioned for each ATM link (see definition of ATM link in 7.1).

An apportionment has also to be made to the internal GOS objectives of the nodes as well as to the UPC, NPC or shaping functions crossed by the connections.

The connection blocking probabilities must be ensured by dimensioning the amount of resources that are allocated to each purpose, as well as by the call-level traffic controls such as routing and service protection, as explained in Recommendation E.737; the cell-level GOS objectives must be ensured by the cell-level traffic controls described in Recommendation E.736.

6.8 Traffic controls

Traffic control functions are classified as cell-level or call-level traffic controls, depending on the type of GOS objectives they are aimed to ensure.

6.8.1 Cell-level traffic controls

Cell-level traffic controls ensure the required cell-level GOS objectives (see 6.7). For instance, in the DBR and SBR transfer capabilities, in which there are cell-level QOS commitments, Connection Admission Control (CAC) operates at connection set-up request epochs and limits the number of established connections in order to meet these commitments. CAC operates on the basis of a combination of the Source Traffic Descriptor (STD) parameters (see Recommendation I.371) and Cell Traffic Variables (see Recommendation E.716) of the connections. When STD parameters are used, as they represent deterministic bounds on the behaviour of the connection, usage or network parameter controls are used to ensure that these traffic bounds are not exceeded, thus avoiding GOS degradations.

To provide different treatment to connections with different GOS objectives, priority controls are used. These controls consist in appropriate service disciplines in queues giving access to the output port links or internal resources of the nodes.

In addition, adaptive resource management controls (also called feedback controls) may also be used to ensure a certain cell-level QOS while tailoring in real-time (during the lifetime of the connections) resource allocation to the actual resource needs of the connections. This is the case in ATM Block Transfer (ABT) or Available Bit Rate (ABR) transfer capabilities.

CAC is defined in Recommendation I.371 at an end-to-end level. However, throughout the E.730- and E.740-Series of Recommendations a local viewpoint will be adopted. Connection admission control procedures described in this Series deal with the problem of accepting or rejecting a connection set-up request at each stage. Two types of local CAC exist, one for accepting connections on an ATM link, another for accepting VCCs on a VPC, as will be explained in 7.1 and 7.2. End-to-end acceptance of a connection requires approval of CAC at each stage along a network path joining the connection endpoints. Routing deals with the selection of network paths for connection requests and is out of the scope of CAC, as it is understood in the E.730- and E.740-Series of Recommendations.

The cell-level traffic controls, defined in Recommendation I.371, are considered from a traffic engineering point of view in Recommendation E.736.

6.8.2 Call-level traffic controls

Call-level traffic controls cooperate to provide the required call-level GOS objectives (see 6.7) in an economical way.

For instance, service protection methods like bandwidth reservation may be used to improve the blocking probabilities for connections with large bandwidth requirements, or to improve GOS in case of local overload. Usage of service protection methods generally results in resource savings and are therefore tightly coupled with dimensioning. Their application is described in Recommendation E.737.

Routing schemes may also be viewed as call-level traffic controls. As such, they have a significant impact on the resources needed to achieve a certain call-level GOS. In Recommendation E.737, those aspects of routing most directly related with dimensioning will be considered. It must be noted, however, that the global problem of selecting and implementing a certain routing strategy is out of the scope of the E.730- and E.740-Series of Recommendations.

Other call-level traffic controls such as network management controls (call gapping, etc.) are mainly intended to assure acceptable network performance in case of overload or failures and do not have a direct influence on dimensioning. This kind of control is out of the scope of E.730- and E.740-Series of Recommendations.

7 Resources in the ATM layer: definitions and implications

7.1 ATM link

The basic resource in the ATM layer is the ATM link. An ATM link is a transmission path together with its associated buffer in the upstream node. An ATM link is defined by a set of parameters and attributes determining its capacity. A key requirement is that from a traffic engineering point of view the capacity of an ATM link can be considered as well delimited, without being affected by the traffic carried by other links. This allows the calculation of the number of connections that can be carried by a given ATM link with no information on the state of the rest of the network. This focus substantially reduces the complexity of traffic controls and dimensioning methods.

7.1.1 Capacities of an ATM link

The parameters and attributes determining the capacity of an ATM link are:

- The transmission capacity, or bandwidth, characterized by its cell rate. The transmission capacity is unidirectional and is "fully accessible" in the sense that the only access restriction derives from the total amount of allocated cell rate.

- The queueing buffer capacity, characterized by the number of cells that can be waiting for transmission.
- The priority control mechanisms for cell delay and cell loss (e.g. FIFO, head of line, loss priorities, weighted fair queueing, etc.) as well as the values of the parameters defining the mechanisms.

If the upstream node is pure output buffered (all queueing in the node occurs at output-port buffers and each output port has its own buffer), the delimitation of the buffer of each link is straightforward.

However, the node can be organized in other ways, e.g. a shared buffer for several output ports. In these cases, in order to simplify problems of CAC and dimensioning, a logical buffer can be assigned to each ATM link. The size of this logical buffer should be such that, for the traffic conditions in which the node is intended to operate, the cell loss ratios (for the different cell flows which the link is intended to carry) in the actual link are not higher than those corresponding to the link with its assigned logical buffer.

The priority mechanism information complements the transmission and buffer capacity parameters, since it allows the calculation of the numbers of connections with different cell-level GOS objectives that can be carried by the ATM link. Note that different priorities and thus different cell-level GOS objectives can be provided in an ATM link to different VPCs, or to different VCCs carried on VPCs starting in the same node as the link, but not to individual VCCs carried on VPCs not starting in the link.

The delimitation of the ATM link capacities allows the global end-to-end decision of acceptance of a connection to be decomposed into local decisions. As stated in 6.8, the term CAC is used in these Series to designate the decision on one ATM link or, as discussed below, on one VPC.

7.1.2 Relation between ATM link, VPC and VCC

Each ATM link has its own CAC function, logically placed in the node where the link starts, to decide on acceptance of connections and, in case of acceptance, to reserve link resources for the connection. The network operation can differ for VPCs with several VP links or with only one VP link:

- **For VPCs with several VP links:** When the establishment of the VPC is requested, the CAC of each of the successive ATM links on which it has to be established decides on acceptance of the VPC and, in case of acceptance, reserves link resources for it; in case of network-to-network or network-to-user VPCs, when VCCs are established on a VPC, the CAC of the VPC, logically placed in the node in which the VPC starts, is responsible for their acceptance since the VCCs will use resources already reserved for the VPC; in the case of user-to-user or user-to-network VPCs, the acceptance of VCCs on a VPC is the responsibility of the user.

The multilink VPC frees the intermediate nodes from operating on the individual VCCs and allows these nodes to operate on them as a whole. The VPC is also a means to coordinate the pre-reservation of resources for a group of VCCs with some common characteristics through several stages of the network.

- **For VPCs with only one VP link:** In this case the VPC has no intermediate nodes, thus, neither the advantage of nodes operating a bundle of VCCs as a whole nor the advantage of coordinating the pre-reservation of resources in several network stages exist; pre-reservation of resources in an ATM link for VCCs with some common characteristics can be done by the CAC function of the ATM link without the need to define a common VPC for those VCCs. Moreover, the clear partitioning of responsibilities between the CAC of the ATM link and the CAC of the VPC, as described above, is not required for VPCs with only one VP link since both CAC functions are in the same node. More flexible solutions are possible in this case. Thus, most of the objectives as well as the requirements for defining VPCs with several VP links do not apply for VPCs with one VP link. Nevertheless, the VPC can also be used in this case to identify a bundle of VCCs for which link resources are reserved in advance;

however, another option is to use the VPC only as a logical identifier without any relevance for traffic engineering. The two options can be described as follows:

- a) **VCCs established on VPCs:** As in the previous case, establishment of VPCs is previously requested and the CAC of the ATM link decides on their acceptance and reserves resources for them; when the establishment of VCCs on a VPC is requested, their acceptance is the responsibility of the CAC of the VPC.
- b) **VCCs directly established on the ATM link:** The CAC of the ATM link directly decides on the acceptance of VCCs.

With option b), several implementations are possible to inhibit the role of the VPC; the chosen implementation is not significant for the purposes of this Recommendation, only the effect achieved.

It is possible that both VCCs directly carried on the ATM link and VCCs carried on VPCs (which, in their turn, are carried on the ATM link) coexist in the same ATM link. The CAC of the ATM link decides on the acceptance of VCCs directly established on the ATM link and on the acceptance of VPCs, while the CAC of each VPC, logically placed in the node in which the VPC starts, decides on the acceptance of the VPCs established on the VPC. Note that the partition of functions between the CAC of an ATM link and the CACs of the VPCs starting in this ATM link is only a logical partition, which does not necessarily correspond to actual implementations, given that all of these CAC functions are in the same node.

7.2 VPC as a connection and as a resource

Establishment of network-to-network, user-to-network and network-to-user VPCs are part of network configuration. As was said in 7.1, when the VPC has several VP links and optionally when it has only one VP link, the CACs of the ATM links, on which the VPC is established, reserve link resources for the VPC from the moment at which it is established. In case of network-to-network or network-to-user VPCs, a CAC of the VPC, logically placed in the upstream node of the VPC, is required to decide on acceptance of VCCs through the VPC. Thus, it is necessary to view the VPC in two different ways:

- From the point of view of the ATM links on which the VPC is established, it is seen as a connection to which the CAC policy of the ATM links is applied. The VPC is defined by several traffic parameters and a set of cell-level GOS objectives. These parameters are the input for the CAC of the ATM links.
- From the point of view of the VCCs, a network-to-network or a network-to-user VPC is seen as a resource whose CAC policy is applied to the VCCs. The VPC as a resource is defined by a set of capacity parameters which are closely related to the traffic parameters of the VPC viewed as a connection. The acceptance or rejection of VCCs in the VPC is under the network's responsibility and is performed by the CAC of the VPC which evaluates if the capacities of the VPC are enough to accept VCC set-up requests.

A user-to-user or user-to-network VPC is seen as a connection, but not as a resource, since the decision on acceptance or rejection of VCCs on these VPCs is made by the user.

For a network-to-network or network-to-user VPC of only one VP link there are two options, as indicated in 7.1. If option a) is chosen, the VPC behaves as a connection and as a resource (the same as network-to-network VPCs with several VP links). If option b) is chosen, the VPC cannot be seen as either a connection or as a resource, and thus does not have any relevance for traffic engineering. In this case, the VPC does not have CAC, but the CAC policy of the ATM link applies directly to the VCCs.

The cell-level GOS objectives of a VPC are derived from the GOS objectives of the VCCs which are intended to be established on the VPC, as explained in 6.7. The compatibility of the GOS objectives of the VPC with those of the VCCs requesting to be established on it could be checked, at connection set-up, by the CAC of the VPC.

Different priority treatments can be provided to individual VCCs of a network-to-network VPC in its first ATM link, but not in subsequent ATM links³. Thus, the cell-level GOS objectives of a VPC can be different for individual VCCs; however this difference is limited by the fact that different GOS objectives for individual VCCs can be allocated in the first ATM link, but not in the subsequent ATM links.

7.3 Characterization of network-to-network VPCs

Which parameters are relevant for characterizing a network-to-network VPC depend on the application. These connection parameters do not have to coincide with the traffic parameters of any ATM transfer capability. The parameters may be source traffic descriptors, defined in Recommendation I.371, or cell traffic variables, defined in Recommendation E.716. The main difference between traffic descriptors and traffic variables is that, while traffic descriptors represent a deterministic bound on the behaviour of the connection, traffic variables represent a probabilistic behaviour of the connection and can provide a more thorough characterization of the traffic.

7.3.1 Characterization by traffic descriptors

The CAC of the VPC must ensure that the traffic parameters (or their corresponding capacity parameters) of the VPC are not exceeded. If traffic descriptors are used to characterize the VPC, since a traffic descriptor represents a deterministic bound, the probability that this bound is exceeded at any instant should in principle be zero⁴. A possible solution could be to allow a negligible fraction of cells on admitted VCCs to violate the traffic descriptors of the VPC. In general, this fraction should be negligible in comparison with the CLR requirements of any connection established on any of the ATM links on which the VPC under consideration is established.

This solution would be inefficient because either:

- 1) a large value is given to CDVT (and, in case of SBR DBC, also to IBT) and it leads to a large amount of resources required by the VPC in the ATM links; or
- 2) a small value is given to CDVT (and IBT) and then few VCCs can be accepted in the VPC.

Therefore it is recommended either to enforce the traffic descriptors by shaping the VPC, or to use traffic variables for characterizing the VPC, since they are not deterministic bounds (see 7.3.2).

In addition to allow a more efficient VPC, the shaping prevents interference between the VPC and the rest of connections in the ATM link, thus allowing the shaped VPCs to be used for some special applications (see 9.3.2). On the other hand, the shaping requires a greater complexity in the node where the VPC starts.

Hereafter we just consider shaped VPCs when they are characterized by traffic descriptors.

7.3.1.1 DBR VPCs

A DBR VPC is characterized by PCR and CDVT of the total cell flow ($CLP = 0 + 1$ cell flow).

The shaping function must be at the origin of the VPC, thus within the node where it starts. The shaper could be integrated in the queueing mechanism of the first ATM link of the VPC. Figure 7-1 shows a model of how an integrated shaping of a DBR VPC could be made. There is a separate buffer for the VPC to be shaped. Each buffer is visited to take a cell from it at a certain rate. If the VPC, seen as a connection, is characterized by a PCR = π , the VPC buffer is visited at a rate π . This rate π cannot be exceeded even when no cells are waiting in the other buffers. In all likelihood due to the particular cell rate of the ATM link and of the VPCs on the ATM link, there will be a certain jitter in the visiting rate of the VPC buffer which will lead to a certain CDVT of the VPC, which, with an appropriate scheduler, can be made very small.

³ Different loss treatment according to CLP bit can be provided (if implemented) in any ATM link, but without differentiating (except in the first ATM link) individual VCCs.

⁴ Even in the simple case of deterministic bit rate VCCs and where the VPC is characterized by a PCR and a cell delay variation tolerance, and where the CAC limits the sum of the peak rates of the admitted VCCs to be no greater than the PCR of the VPC, the realized traffic could still at times exceed the cell delay variation tolerance of the VPC.

The buffer assigned to the VPC does not need to be FIFO, but rather can be a more complex buffer structure together with priority control mechanisms for cell delay and cell loss. It would allow to provide different priority treatments to individual VCCs of the VPC in its first ATM link.

A shaped DBR VPC seen as a resource on which VCCs are carried behaves as if it were an ATM link. It has the same type of capacity parameters or attributes as an ATM link: the transmission capacity (equal to the PCR, π , of the VPC), the queueing buffer capacity (that of the VPC buffer) and the priority control mechanisms (those implemented in the shaper). Consequently, the CAC of a shaped DBR VPC could use the same methods as the CAC of an ATM link.

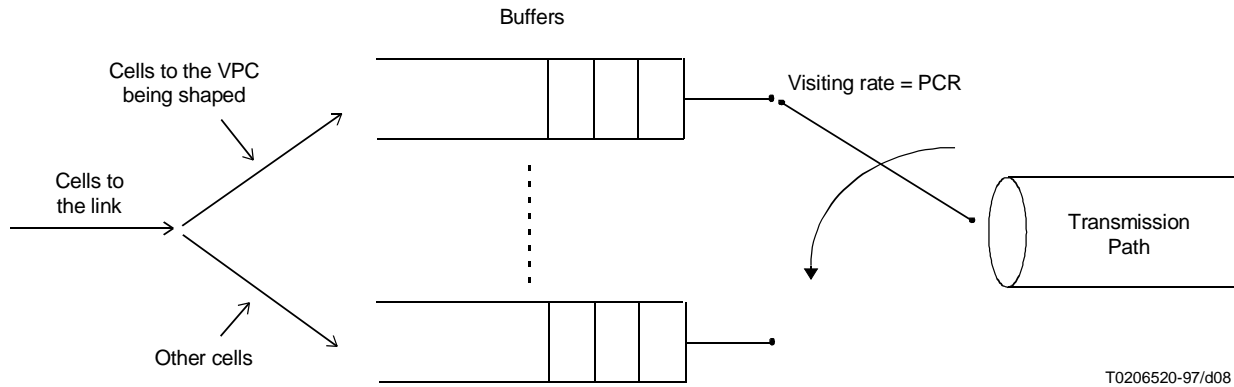

Figure 7-1/E.735 – Model of shaping function integrated in the queuing mechanism of the ATM link

7.3.1.2 SBR VPCs

Network-to-network or network-to-user SBR VPCs are left for further study.

7.3.2 Characterization by traffic variables

A network-to-network VPC, seen as a connection, can be characterized by a set of traffic variables. Examples of traffic variables which could be used to characterize a VPC are the mean cell rate, variables related to the distribution of the instantaneous rate or variables related to the number of cell arrivals exceeding a rate (see Recommendation E.716). A network-to-network VPC characterized by traffic variables does not need to be shaped.

Different priority treatments can be provided to individual VCCs of a VPC in its first ATM link. However, this Recommendation considers only VPCs described by traffic variables in which the same priority treatment is provided to individual VCCs.

The capacity of the VPC, seen as a resource on which VCCs are established, is defined by the same traffic variables which describe the VPC as a connection. The CAC of the VPC must accept VCCs while the traffic variables declared for the VPC are not exceeded.

Two types of network-to-network VPCs, based on different criteria to choose traffic variables to characterize them are considered in this Recommendation: uncontrolled constant rate VPCs and variable rate VPCs.

The criterion used to characterize uncontrolled constant rate VPCs is to get simple solutions: the resources which have to be allocated to an uncontrolled constant rate VPC in each of the ATM links on which it is established are independent of the capacity of the link, which simplifies the logical reconfiguration of the network (see 9.3.4). However, the use of uncontrolled constant rate VPCs (as well as the use of DBR VPCs) does not allow for statistical multiplexing between VCCs carried on different VPCs of a same ATM link, and it may lead to less efficient solutions (see 9.2.1).

On the contrary, the criterion used to characterize the variable rate VPCs is to get efficient solutions: it allows for statistical multiplexing between VCCs carried on different VPCs of a same ATM link and it may lead to a greater efficiency (see 9.2.1). However, the resources needed by a variable rate VPC in each of the ATM links on which it is established may depend on the link capacities, which complicates the logical reconfiguration of the network (see 9.3.4).

7.3.2.1 Uncontrolled constant rate VPCs

The uncontrolled constant rate VPC is characterized by a rate and a negligible CDV with respect to a reference arrival process, e.g. to a Poissonian process (see definition of negligible CDV in Recommendation E.736).

This characterization may be used when the VCCs carried on the VPC are characterized by their PCR or by the stationary distribution of their instantaneous rate, and have negligible CDV with respect to the same reference process.

If an uncontrolled constant rate VPC is used to carrying VCCs characterized by their PCR, its CAC is very simple: it can accept new VCCs (with negligible CDV with respect to the same reference process as the VPC) while the sum of the PCRs of the accepted VCCs does not exceed the rate declared for the VPC. If the VCCs are characterized by their rate distribution and statistical multiplexing within the VPC is desired, to check whether the rate of the VPC is exceeded is more difficult than a simple sum (see Recommendation E.736). In this case, there will be a certain probability that the declared rate for the VPC is exceeded. The CAC of the VPC must ensure that the fraction of cells on admitted VCCs that violate the rate declared for the VPC is negligible in comparison with the CLR objectives for any connection established on any of the ATM links on which the VPC is established.

7.3.2.2 Variable rate VPCs

A variable rate VPC is characterized by traffic variables chosen to allow statistical multiplexing of the VCCs in the VPC with other connections on the ATM links transversed by the VPC.

A variable rate VPC can be defined in terms of the Equivalent Cell Rate (ECR) concept (see 8.2). This is possible when the CAC of the ATM link is also based on ECR. The problem of achieving this kind of statistical multiplexing when the CAC of the ATM link is not based on ECR is for further study.

As explained in 8.2, the ECR is a cell rate attributed to a connection such that cell-level GOS objectives are satisfied on an ATM link or network VPC as long as the sum of equivalent cell rates is not greater than the rate of the ATM link or VPC.

A variable rate VPC with only one VP link is characterized by its ECR on the ATM link. The CAC of the variable rate VPC admits VCCs as long as the sum of their ECRs (evaluated with respect to the whole ATM link) is kept not greater than the ECR of the VPC⁵.

⁵ The CAC of a DBR VPC or of an uncontrolled constant rate VPC could also be based on the ECR concept and to admit VCCs as long as the sum of their ECRs is kept not greater than the VPC rate. But an important difference with respect to the variable rate VPC is that the ECRs of the VCCs of a DBR VPC or of an uncontrolled constant rate VPC are evaluated with respect to the VPC capacities, while the ECRs of the VCCs of a variable rate VPC are evaluated with respect to the link capacities.

A multilink variable rate VPC may be characterized either by a single ECR value (the same in all the ATM links on which it is carried), or by a different ECR value in each of the ATM links. If b_i^j is the ECR of VCC_i evaluated with respect to ATM link j , and B^j is the value assigned to the ECR of the VPC in ATM link j , the CAC of the VPC must assure that for every ATM link j on which the VPC is carried:

$$\sum_i b_i^j \leq B^j \quad (7-1)$$

In order that the CAC decision of admittance of VCCs on the VPC can be made at just the originating node of the VPC, the relevant information of each ATM link (see Recommendation E.736) must be given to this node when the VPC is established.

7.3.3 Change of the characterization in an intermediate point

A third option is to shape or to perform NPC of a VPC in an intermediate point, either between two nodes crossed by the VPC or within an intermediate node. Thus, upstream of the shaper or NPC, the VPC can be characterized by traffic variables and downstream of the shaper or NPC, it can be characterized by traffic descriptors. The VPC could be uncontrolled constant rate or variable rate VPC upstream of the shaper (or NPC) and DBR VPC downstream of the shaper (or NPC).

The relation between the traffic variables defining the VPC upstream of the shaper or NPC, the traffic descriptors of the VPC downstream of the shaper or NPC and the length and structure of the buffer of the shaper (or the tolerance parameter of the GCRA in the NPC) must be such that the losses and delays introduced by the shaper or NPC are compatible with the portion of cell-level GOS objectives of the VPC allocated to this function.

The capacity parameters of the VPC seen as a resource are the same as the traffic variables characterizing it upstream of the shaper or NPC.

This third option may be useful for those applications which require the use of a shaped VPC and the node where the VPC starts has no capability to shape it. However, the usefulness of this option is limited to applications which do not require to shape the VPC just at its origin.

7.4 ATM link set and VPC set

The following definitions of ATM link set and VPC set are useful for traffic engineering:

- An ATM link set is the set of all the ATM links with the same direction of transmission interconnecting two ATM nodes without any intermediate ATM node.

Two ATM nodes interconnected by ATM links without any intermediate ATM node are called adjacent ATM nodes. Two ATM link sets are defined between two adjacent ATM nodes, one for each direction of transmission.

- A VPC set is the set of all the VPCs with the same direction of transmission interconnecting two VC nodes without any intermediate VC node.

The term VC node also includes the VC part of a VP-VC node. Two VC nodes interconnected by VPCs without any intermediate VC node are called adjacent VC nodes. Two VPC sets are defined between two adjacent VC nodes, one for each direction of transmission.

The concept of ATM link set is used in a VPC-based bearer service network and the concept of VPC set in a VCC-based bearer service network. Both concepts are used in integrated networks. The link sets and VPC sets are dimensioned to satisfy target values of connection blocking probability.

By means of call-level traffic controls such as service protection, explained in Recommendation E.737, different connection blocking probabilities can be provided in a link set or in a VPC set to different connection classes.

8 Relation between cell-level traffic control and dimensioning

The task of dimensioning in B-ISDN applies to both ATM link sets and VPC sets. ATM link set dimensioning specifies the number of links and, for each link, bandwidth and buffers and, in case that some types of controls (as priority control and bandwidth reservation) are implemented, to determine the values of parameters or thresholds which define these controls. VPC set dimensioning specifies the number of VPCs and the values of the capacity parameters of each one. Of course, in the initial phases of network dimensioning (e.g. in long-term planning) only the amount of physical resources have to be evaluated. In later phases, the dimensioning has to be more complete.

There is a close relation between VPC set and link set dimensioning: the capacity parameters of the network-to-network VPCs obtained in the VPC set dimensioning determine their traffic parameters when seen as connections which have to be established through ATM links; the traffic parameters of these VPCs are input for the link set dimensioning.

8.1 Iterative approach

Given a certain network configuration, a basic input for the dimensioning of VPC sets or ATM link sets is the amount of resources needed for any connection (VCC in case of VPC sets, VCC if directly established on the link, or VPC in case of ATM link sets) to be established in such a way as to satisfy its specified cell-level GOS objectives. This obviously depends on the behaviour of the cell-level traffic controls responsible for assigning resources to each connection.

Since the CAC algorithm, in deciding on the acceptance of a connection, takes into account all the cell-level controls implemented (UPC/NPC, priorities, adaptive resource management controls, etc.), this algorithm summarizes all the cell-level controls from the point of view of the resources needed by a connection. The CAC, in deciding on acceptance or rejection, is implicitly assigning resources to each connection.

Thus, dimensioning has to take into account the resources allocated to each connection by the CAC. However, in general the problem is complex because the amount of resources depends not only on the traffic parameters of the connection, but also on the traffic parameters of the other connections established on the ATM link (or on the VPC) and on the capacity of the ATM link (or of the VPC). As a consequence, the resources needed by a connection depend on the capacity of the link (or of the VPC) while, in its turn, the number and the capacity of the links (or of the VPCs) must be dimensioned taking into account the resources needed by each connection.

Therefore, the process of dimensioning the network is an iterative one in which, starting with a certain configuration, the amount of network resources required by each connection can be evaluated and this, in its turn, affects the network configuration scheme.

These ideas, which apply to both VPCs (for which the connections are the VCCs) and ATM links (for which the connections are the VCCs directly established on the ATM link and the VPCs) may be expressed in a more formal way as follows:

The amount of resources allocated by the CAC to the connections depends:

- on the traffic parameters of the connections. The set of traffic parameters characterizing a given connection i may be denoted by:

$$\{T_{1i}, T_{2i}, T_{3i}, \dots\}$$

- on the capacity parameters of the ATM link (or of the VPC). These parameters may be denoted as:

$$\{C_1, C_2, C_3, \dots\}$$

Given an ATM link (or a VPC) with a certain set of capacity parameters, it is possible to define a set of functions from which the amount of resources required by a group of connections may be obtained. More specifically, a group of

connections may be established on the ATM link (or on the VPC) if and only if:

$$F_j(T_{11}, T_{21}, T_{31}, \dots, T_{12}, T_{22}, T_{32}, \dots, C_1, C_2, C_3, \dots) \leq C_j \quad (8-1)$$

where a function F_j might be defined for each link (or VPC) capacity parameter, C_j . These functions also depend on the cell-level GOS objectives of the connections.

The decision of acceptance or rejection of a new connection (the CAC algorithm) may then be expressed in terms of these functions. In fact it suffices to check if their values for a group of connections including both the already established ones and the new ones are still not greater than the parameters $\{C_j\}$.

The functions $\{F_j\}$ are input for dimensioning, because they implicitly determine the resources needed by each connection. The need of iteration mentioned before may be seen here as a consequence of the fact that these functions depend on the ATM link (or VPC) capacities.

Much research work has been done to obtain simple expressions of the functions $\{F_j\}$ which allows both simple CAC operation and simple dimensioning formulas. The most extended approach is the one based on the equivalent cell rate concept described in 8.2.

Nevertheless, the functions $\{F_j\}$ used for dimensioning may be approximations of the functions $\{F_j\}$ which represent the CAC behaviour, the precision requirements of these approximations depending on the stage of the resource allocation process. In the initial phases of network dimensioning (e.g. in long-term planning), when the CAC has not been decided and accurate traffic parameters cannot be foreseen, simpler functions modelling the hypothetical CAC behaviour can be used for dimensioning. In later stages, like network configuration, more precision is required, and the functions modelling the CAC for dimensioning purposes must represent the actual CAC operation more accurately.

8.2 Equivalent cell rate

The equivalent cell rate concept allows a simple CAC operation and easier dimensioning formulas. Each connection is described by one parameter, B_i , the equivalent cell rate, which can be written either as:

$$B_i = B(T_{1i}, T_{2i}, T_{3i}, \dots, C_1, C_2, C_3, \dots) \quad (8-2)$$

or as:

$$B_i = B(T_{1i}, T_{2i}, T_{3i}, \dots, C_1, C_2, C_3, \dots, \alpha) \quad (8-3)$$

where:

$$\alpha = \alpha(T_{11}, T_{21}, T_{31}, \dots, T_{12}, T_{22}, T_{32}, \dots, C_1, C_2, C_3, \dots) \quad (8-4)$$

In the first case (Formula 8-2), the equivalent cell rate of a connection is only dependent on the traffic parameters of its own connection and on the capacity parameters of the ATM link (or of the VPC). In the second case (Formulas 8-3 and 8-4), it is also dependent on the traffic parameters of the other connections, this dependency being manifested through the parameter α .

The ATM link (or the VPC) capacity is described by one parameter, U , its total cell transmission rate in case of an ATM link (its PCR, rate or equivalent cell rate in case of DBR, uncontrolled constant rate or variable rate VPC respectively)⁶. The set of conditions given by Formula 8-1 is reduced to only one simple condition:

$$\sum_i B_i \leq U \quad (8-5)$$

⁶ Note that other parameters defining the capacity of the link (or of the VPC), as e.g. the buffer length, are also taken into account since the equivalent cell rate of the connections may depend on it.

A group of connections may then be established on the ATM link (or on the VPC) if and only if the sum of the equivalent cell rates of the established connections is not greater than the total cell transmission rate of the ATM link (or the PCR, rate or equivalent cell rate of the VPC).

Recommendation E.736 provides methods to evaluate the equivalent cell rate of the connections, and Recommendation E.737 uses the equivalent cell rate of the connections as an input for dimensioning.

9 Strategies for network configuration

The existence of the VP concept results in a great flexibility in the management of network resources at the ATM layer. In particular, it enables the implementation of connection control and resource allocation functions on aggregated groups of VCCs instead of on individual VCCs. The strategies for the use of VPCs should attain acceptable trade-offs between advantages, drawbacks and requirements of the use of VPCs. This clause is intended to clarify these matters in order to give guidance to the operators in the choice of their strategies.

9.1 Applications of VPCs

The applications listed below are examples of the potential use of VPs in network engineering.

9.1.1 VPC-based bearer services

Establishment of user-to-user VPCs provides the user with an end-to-end cell transfer capability in which no connection-related functions at the VC level are performed: CAC, UPC, routing, adaptive resource management, etc. are performed for the VPC as a whole. For user VPCs carrying several VCCs, there may be significant savings in the network resources devoted to traffic control.

This may be used for instance for the provision of a broadband semi-permanent point-to-point fixed bandwidth information transport facility (leased line). Also some networks are built with only VP cross-connects.

9.1.2 Segregation of overlay logical networks

Virtual paths may be viewed (see 7.2) as resources with a certain capacity. Thus, they may be used to partition network resources for the deployment of several overlay networks over the same physical infrastructure⁷. This may be convenient for operation and control purposes. Although this kind of segregation may be achieved by using physically separate resources (e.g. different ATM links) for each subnetwork, the use of VPCs is much more flexible. Examples of this kind of application are the use of network-to-network VPCs for:

- Segregation of resources dedicated to semi-permanent and to switched user connections: In a network with semi-permanent VPC-based bearer services operated by the management plane and switched VCC-based bearer services operated by the control plane, the segregation of the resources dedicated to the two types of services avoids the need of real-time coordination of management and control planes.
- Reservation of capacity for different network operators sharing the same physical network.
- Provision of virtual private networks.
- Partition of resources by means of shaped VPCs for different transfer capabilities or for different QOS classes so they can be controlled and operated independently.

⁷ Network-to-network VPCs allow the segregation of a VCC-based bearer service network into several overlay subnetworks, but they do not allow the segregation of a VPC-based bearer service network. A network with both VCC and VPC-based bearer services can be segregated by means of network-to-network VPCs into one VPC-based bearer service subnetwork and one or several VCC-based bearer service subnetworks.

9.1.3 Reduction of control costs

Establishment of network-to-network VPCs between non-adjacent ATM nodes simplifies and accelerates connection set-up, release and renegotiation procedures, since connection control for a VCC has to be performed only at the originating nodes of the VPCs involved in the connection. Thus, intermediate nodes (those through which VPCs have been set up) do not have to perform any connection control functions when VCCs are set up or released allowing both simpler intermediate nodes (e.g. VP-cross-connects instead of VC-switches) and smaller connection set-up times. This strategy may also ease the evolution from cross-connected networks to truly switched networks.

9.1.4 Flexibility of logical network configuration

Setting up of network-to-network VPCs provides a means to support a flexible logical network architecture (for VCC-based bearer services) over a fixed physical infrastructure. It may be a tool to utilize physical network capacity more efficiently than fixed capacity assignment. The logical network may be reconfigured without modifying the physical network: new VPCs may be defined or the bandwidth of existing VPCs may be modified with management functions to cope with different situations.

There are various schemes of reassignment of VPC capacities. A time-dependent scheme is to reassign VPC capacities triggered by a predetermined schedule (e.g. time of day, day of week, etc.). An event-dependent scheme is to reassign the capacities triggered by certain events such as node or link outages or the occurrence of an excessive connection blocking at a VPC. Note, however, that the effectiveness of the reassignment of capacity depends on the level of traffic variations and non-coincidence busy hours in the network. For implementation, attention should also be paid to complexity of the mechanisms for the capacity reassignment.

9.2 Drawbacks of the use of VPCs

It has been shown in 9.1 that there are many applications of the use of VPCs in an ATM network. However, the definition of network-to-network VPCs implies the partitioning of the network resources, and it can produce a problem of diseconomy of scale, both at the cell level and at the connection level, which has the negative impact of reducing the traffic that may be carried by the network. This impact has greater weight on more costly transmission facilities, such as transoceanic links.

9.2.1 Diseconomy of scale at cell level

The use of DBR or uncontrolled constant rate VPCs in a link implies the partitioning of the resources of the ATM link and thus decreases the sharing of resources by the established connections. It increases the equivalent cell rate of the connections (see clause 8 and Recommendation E.736) and thus decreases the number of connections which can be simultaneously established. This problem is avoided or at least significantly reduced by using variable rate VPCs.

9.2.2 Diseconomy of scale at connection level

The definition of network-to-network VPCs implies limiting the accessibility of VCCs to a particular amount of bandwidth, less than the ATM link set bandwidth: a VCC may be refused admission because of lack of capacity on a VPC even when other VPCs sharing the same ATM link set have spare capacity. This results in an increase of the connection blocking probabilities (and thus in a decrease of the network capacity) as compared with the case where all the resources are available for the establishment of VCCs.

The diseconomy of scale in the connection level equally affects VPCs defined by traffic descriptors or by traffic variables. The effect could be alleviated or, in some cases, even avoided with call-by-call reassignment of VPC capacity, i.e. with dynamic reassignment of capacity to VPCs made at VCC set-up request instants. But this is very difficult to carry out if it affects the resources needed by the VPC in several of the links in which it is carried, since the CAC of all

the affected links, which are placed in different nodes, would have to be involved⁸. Thus, call-by-call reassignment of VPC capacity is not feasible unless it only affects the resources needed by the VPC in its first ATM link. The latter condition applies to:

- VPCs of one VP link⁹;
- Multilink VPCs in the following particular cases:
 - DBR VPCs, in which the buffer length or the priority control mechanisms of the shaper, but not the peak rate, is modified;
 - VPCs defined by traffic variables in which variables describing partial cell flows (i.e. cell flows with certain priority treatment in the first ATM link of the VPC) are modified, but not the variables describing the total cell flow.

Even in these cases, the call-by-call capacity reassignment may be difficult if VPCs (as well as the CAC of the ATM links) are operated by management plane and VCCs (as well as the CAC of the VPCs) by control plane, because it would require real-time communication between both planes.

9.3 Requirements and guidelines

Taking into account the decrease of network capacity explained above, the strategy of the network operator should consider the establishment of a network-to-network VPC only in the case in which the benefits obtained (reduction of control costs, simplicity for the operation, etc.) outweigh the increase in the transmission costs. As an example, note that definition of network-to-network VPCs is the only simple means of integrating VP cross-connects in a network providing on-demand VCCs.

The various options on the type of VPC can lead to different decreases of network capacity. On the other hand, some of the applications described in 9.1 impose requirements on the option chosen.

Besides any constraints imposed by the application, the choice, if any, of VPC depends on a trade-off of efficiency versus complexity. The following guidelines are from the viewpoint of increasing efficiency:

- VCCs directly carried on the ATM link are more efficient than VCCs carried on VPCs of one VP link, since VCCs directly carried on the ATM links do not have the drawbacks described in 9.2.
- Variable rate VPCs are more efficient than DBR or uncontrolled constant rate VPCs since the diseconomy of scale in the cell level is smaller in the first case. An exception to this rule could occur when the VPC carries DBR VCCs.
- Call-by-call reassignment of VPC capacity, up to the extent in which it is feasible (see 9.2.2), is more efficient than VPCs with fixed capacity (or with only long-term capacity reassignment), since the call-by-call reassignment mitigates the problem of diseconomy of scale in the connection level.
- To shape VPCs in an intermediate point is normally more efficient than to perform Network Parameter Control (NPC) of the VPC: for the same values of the traffic variables and of the traffic descriptors describing the VPC upstream and downstream of the shaper (or NPC) respectively, the CLR produced by the NPC is greater than that produced by the shaper. On the other hand, the shaper introduces delays and the NPC does not.

On the other hand, shaping of DBR VPCs, the management of variable rate VPCs or the call-by-call reassignment of VPC capacity require additional functionality in the network.

⁸ The problem is even more complex if the increase of capacity of a VPC is made at expense of decreasing the capacity of other VPCs, since the CACs of these other VPCs would also have to be involved to check if their capacity reduction is compatible with the capacity needed for the already established VCCs.

⁹ Note that to define variable rate VPCs of one VP link with call-by-call reassignment of capacity may be equivalent to have the VCCs directly established on the link [option b)] described in 7.1.2.

In order to see how these guidelines can be applied, subclauses 9.3.1 to 9.3.4 examine the requirements of each of the applications listed in 9.1, and subclause 9.3.5 explains how to deal with different transfer capabilities or QOS classes when the operator desires to establish network-to-network VPCs.

9.3.1 VPC-based bearer services

This application only requires the use of user-to-user VPCs, which have to be described by traffic descriptors, since the network has to be able to enforce the declared traffic parameters. If no other application is desired, the VCCs not carried on user-to-user VPCs should be directly carried on the ATM links.

9.3.2 Segregation of overlay logical networks

This kind of application is based on the use of network-to-network VPCs regardless of their number of VP links. It requires that the VCCs are carried on VPCs, not directly on the ATM links.

When overlay networks are desired for semi-permanent and switched connections, either DBR, uncontrolled constant rate or variable rate network-to-network VPCs may be used. For reasons of efficiency it will be normally preferable to use variable rate VPCs. Call-by-call capacity reassignment is not appropriate in this case, since it would imply real-time coordination of the management and control planes, and to avoid this coordination is the main objective of this application.

If overlay networks are used for different operators, a clear and controllable division of capacity may be necessary. In this case, shaped DBR VPCs should be used, as the policing attribute of the shaper as well as the shaping itself prevents interference. Call-by-call reassignment of VPC capacity could be against the objectives of this application.

Due to the same reason, if a Virtual Private Network (VPN) uses network-to-network or network-to-user VPCs, they must be shaped DBR VPCs. This avoids the need to monitor individual VCCs of the VPN and even allows the CAC of network-to-network or network-to-user VPCs of the VPN to be under the user's responsibility. Call-by-call reassignment of VPC capacity is also inappropriate for this application.

One option for dealing with different transfer capabilities or different QOS classes is to have, by means of network-to-network VPCs, overlay logical networks, which can be, up to a certain extent, controlled and operated independently. The purpose of this independent and thus simple operation is achieved by the use of shaped DBR VPCs. No additional priority mechanisms are required in the nodes if the VPCs used for each QOS class are shaped just when they start. Moreover, if a multilink DBR VPC is used to carry VCCs with ABR or ABT services, adaptive resource management mechanisms are not needed in the intermediate nodes of the VPC. This strategy is simple (e.g. the resources needed for each transfer capability or QOS class can be dimensioned independently), but it does not normally lead to the most efficient solutions. More efficient solutions can be normally achieved by carrying the VCCs directly on the ATM link and by establishing appropriate priority mechanisms in the nodes. In this application, call-by-call reassignment of capacity is possible, but it decreases the sought independent operation.

In the first B-ISDN implementations, there may be network nodes without priority mechanisms to provide different GOS to connections of different QOS classes, or without the adaptive resource management mechanisms required for providing ABR or ABT services. This problem can be solved by crossing these nodes with shaped DBR VPCs, where a given VPC supports a given transfer capability or QOS class. For this application, if the originating node of a VPC is not capable of shaping it, the VPC can be shaped in an intermediate point that is upstream to the nodes without priority or adaptive resource management mechanisms. It can be made, for example, by adding a shaper at the output of the node where the VPC starts.

9.3.3 Reduction of control costs

This application is based on the use of multilinks VPCs, which may be either DBR, uncontrolled constant rate or variable rate VPCs. From an efficiency viewpoint it will be preferable to use variable rate VPCs. VPCs of one VP link are not useful for this application; therefore, a better efficiency is achieved if the VCCs not carried on multilink VPCs are directly carried on the ATM links. Call-by-call reassignment of VPC capacity (only affecting the resources needed by the VPC in its first ATM link) is compatible with this application.

9.3.4 Flexibility of logical network configuration

This application has the same requirements as the previous one. However, although logical network reconfigurations may be performed with either DBR, uncontrolled constant rate or variable rate VPCs, the reconfiguration task is simpler if DBR or uncontrolled constant rate VPCs are used. The operator has to decide for this application between the greater simplicity for reconfigurations provided by DBR or uncontrolled constant rate VPCs and the greater efficiency normally provided by variable rate VPCs.

9.3.5 Supporting QOS classes when there are VPCs

Subclauses 9.1.2 and 9.3.2 cover the use of network-to-network VPCs for partitioning the resources dedicated to different transfer capabilities or QOS classes. The subject treated here is different. It is how to deal with different transfer capabilities or QOS classes when the operator, due to other applications, desires to establish network-to-network VPCs between two nodes: Is it more efficient to carry all the transfer capabilities or QOS classes in the same VPC or to segregate them? Two cases have to be distinguished:

- **VPCs of one VP link:** Given that different priority treatments can be provided to different VCCs of the same VPC, more efficient solutions can be achieved by carrying all the VCCs in the same VPC, because it decreases the drawbacks mentioned in 9.2.
- **VPCs of several VP links:** In this case, to integrate all the VCCs in the same VPC avoids the drawbacks of 9.2, but it has the problem that different priority treatments to VCCs with different cell-level GOS objectives can only be provided in the first node of the VPC. Thus the intermediate nodes have to provide to the whole VPC the GOS performance objectives required by the VCCs with most stringent requirements. To segregate the transfer capabilities and/or the QOS classes into different VPCs avoids this problem but has the drawbacks of 9.2. The best choice will depend on the scenario. As a general tendency, the integration of transfer capabilities and/or QOS classes in one VPC may be more efficient if the VPC is DBR, since it is not normally very costly to provide stringent GOS objectives to a VPC with constant rate. Due to the same reason, the integration in one uncontrolled constant rate VPC could be efficient if all the VCCs have a moderate CDV and thus the VPC can be defined with a moderate CDV. If variable rate VPCs are used, the segregation into different VPCs could be more efficient. But this general tendency has to be checked in each particular scenario.

10 History

This is the first issue of Recommendation E.735.

ITU-T RECOMMENDATIONS SERIES

- Series A Organization of the work of the ITU-T
- Series B Means of expression: definitions, symbols, classification
- Series C General telecommunication statistics
- Series D General tariff principles
- Series E Overall network operation, telephone service, service operation and human factors**
- Series F Non-telephone telecommunication services
- Series G Transmission systems and media, digital systems and networks
- Series H Audiovisual and multimedia systems
- Series I Integrated services digital network
- Series J Transmission of television, sound programme and other multimedia signals
- Series K Protection against interference
- Series L Construction, installation and protection of cables and other elements of outside plant
- Series M TMN and network maintenance: international transmission systems, telephone circuits, telegraphy, facsimile and leased circuits
- Series N Maintenance: international sound programme and television transmission circuits
- Series O Specifications of measuring equipment
- Series P Telephone transmission quality, telephone installations, local line networks
- Series Q Switching and signalling
- Series R Telegraph transmission
- Series S Telegraph services terminal equipment
- Series T Terminals for telematic services
- Series U Telegraph switching
- Series V Data communication over the telephone network
- Series X Data networks and open system communication
- Series Z Programming languages