



INTERNATIONAL TELECOMMUNICATION UNION

**ITU-T**

TELECOMMUNICATION  
STANDARDIZATION SECTOR  
OF ITU

**D.93**

**CHARGING AND ACCOUNTING IN INTERNATIONAL  
TELECOMMUNICATION SERVICES**

---

**CHARGING AND ACCOUNTING IN THE  
INTERNATIONAL LAND MOBILE TELEPHONE  
SERVICE (PROVIDED VIA CELLULAR RADIO  
SYSTEMS)**

**ITU-T Recommendation D.93**

(Extract from the *Blue Book*)

---

## NOTES

1 ITU-T Recommendation D.93 was published in Fascicle II.1 of the *Blue Book*. This file is an extract from the *Blue Book*. While the presentation and layout of the text might be slightly different from the *Blue Book* version, the contents of the file are identical to the *Blue Book* version and copyright conditions remain unchanged (see below).

2 In this Recommendation, the expression “Administration” is used for conciseness to indicate both a telecommunication administration and a recognized operating agency.

## **Recommendation D.93**

### **CHARGING AND ACCOUNTING IN THE INTERNATIONAL LAND MOBILE TELEPHONE SERVICE (PROVIDED VIA CELLULAR RADIO SYSTEMS)**

*(Melbourne, 1988)*

#### **1 General considerations**

1.1 In the land mobile telephony service, the Home Public Land Mobile Network (HPLMN) will know the location of all operational mobile stations for which it is the home registered network, when the station is operating within its HPLMN or has roamed in accordance with the principles contained in CCITT Recommendations of the Q.1000 series.

1.2 The Visited Public Land Mobile Network (VPLMN) will be able to access and record the necessary details of any mobile station which has roamed and registered with it, such that it can forward all necessary billing information to the HPLMN.

1.3 Mobile stations will only be able to roam to another Public Land Mobile Network (PLMN):

- upon the conclusion of a bilateral agreement between PLMNs,
- upon the granting by the HPLMN of the option to roam to the mobile station.

1.4 As part of the bilateral agreement, the HPLMN should undertake to pay the VPLMN the charges incurred by the HPLMN registered mobile subscribers.

1.5 Examples of the application of the charging and accounting principles, set out below, for various call routing scenarios are given in Annex A.

#### **2 Principles for charging**

2.1 The charge structure and level in any country is a national matter.

##### *HPLMN charging*

2.2.1 The HPLMN is responsible for billing the mobile subscriber for all incurred charges.

2.2.2 Charging structures should be as simple as possible.

2.2.3 The charge would normally consist of two components:

- a network access component;
- a network utilization component.

2.2.3.1 The network access component is intended to cover the cost of making the service available, such costs being independent of network utilization:

- initial registration charge (non-recurring),
- subscription or rental (periodic).

The network access component shall not be included in the international accounts.

2.2.3.2 The network utilization component is intended to cover the costs of the service which are dependent on network utilization:

- utilization charges (covering mobile, national/international elements as applicable),
- any supplementary service charges.

2.2.4 The charges billed to the mobile subscriber should be such as to cover the payments due to the VPLMN plus any handling charges which may also be raised.

##### *VPLMN charging*

2.3.1 The charges raised by a VPLMN against the HPLMN should normally include one or more of the following:

- roaming registration fee (non-recurring)
- roaming subscription (periodic),

- utilization charges (covering mobile, national/international elements as applicable),
- any supplementary service charges.

#### 2.4 *Fixed station charges*

2.4.1 In the case of a fixed station to mobile station international call, the appropriate fixed station to fixed station telephone charge should apply to the calling station.

2.4.2 In the case of a fixed station to mobile station call, the fixed station should always be charged for the call dialled, irrespective of whether the mobile station has or has not roamed; if a mobile station has roamed, a charge for the forwarded element of the call may be raised by the HPLMN against the mobile station.

#### 2.5 *Mobile station to mobile station charges*

2.5.1 In the case of a mobile station to mobile station international call, the appropriate mobile station to fixed station charge should apply to the calling station.

2.5.2 In the case of a mobile station to mobile station call, where the calling mobile station has not roamed, the calling station should always be charged for the call dialled, irrespective of whether the called mobile has or has not roamed. If a mobile station has roamed a charge for the forwarded element of the call may be raised by the HPLMN of the called mobile station. The case where the calling mobile station has roamed is covered by § 2.3.1 above.

### **3 Principles for accounting**

3.1 International traffic originating or terminating at a mobile station will always be routed via the fixed networks of the countries concerned. The Administration of the country where the call originates should therefore include all such traffic in its regular international accounting statements at the normal accounting rates.

3.2 The use of the PLMN in either country should not form part of the international traffic accounts, being covered under the charging aspects.

### **4 Principles for settlements between PLMNs**

4.1 The VPLMN should prepare a statement of the charges payable by the HPLMN for its registered mobile subscribers. The format and frequency of dispatch should be agreed between the two parties. This statement should show the total charge expressed in SDRs or another agreed accounting currency, together with the conversion rate.

4.2 To ensure that the HPLMN has sufficient information for billing purposes, individual statements should be prepared for each registered subscriber. These statements should include the following information:

- a) The period covered by the statement
- b) The subscriber identity in the HPLMN
- c) For each call:
  - i) the date and start time,
  - ii) number called and area code,
  - iii) destination country,
  - iv) duration in minutes and seconds,
  - v) any supplementary services used.

4.3 In the absence of alternative settlement procedures agreed between the PLMNs concerned, settlement of balances shall be effected in accordance with the provisions of the Administrative Regulations [1].

ANNEX A

(to Recommendation D.93)

**Applications of charging and accounting principles  
for various call routing scenarios**

A.1 *Case 1 – Mobile station to a fixed station*

In this case the mobile station A\* is in its home PLMN (country A), makes an international (non-roaming) call to a fixed station B' in country B (see Figure A-1/D.93).

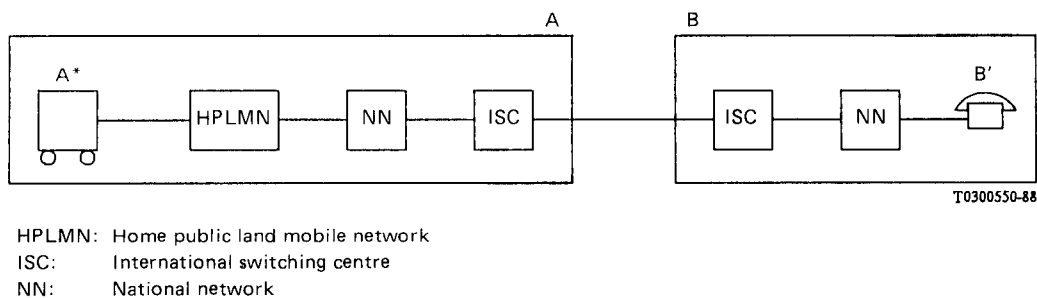

FIGURE A-1/D.93

- Charging: A\* will be billed by its HPLMN for call to country B.
- Inter PLMN settlement: Not applicable.
- Traffic accounting: The call from A to B is included in A's outgoing traffic account.

A.2 *Case 2 – Roamed mobile station to a fixed station*

Mobile station A\* has roamed to PLMN in country B and makes a national call to a fixed station (see Figure A-2/D.93).

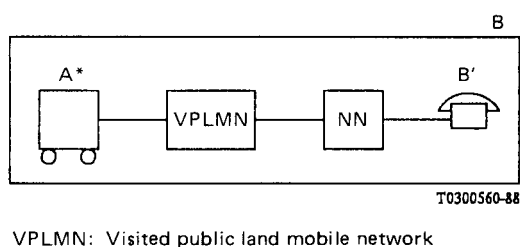

FIGURE A-2/D.93

- Charging: A\* will be billed by its HPLMN based on data provided by the VPLMN.
- Inter PLMN settlement: The HPLMN "A" will reimburse the VPLMN "B" for the charges incurred by the roamer.
- Traffic accounting: Not applicable.

A.3 *Case 3 – Roamed mobile station to fixed station*

Mobile station A\* has roamed to a PLMN in country B and makes an international call.

A.3.1 Case 3A – Call to the home country (see Figure A- 3/D.93)

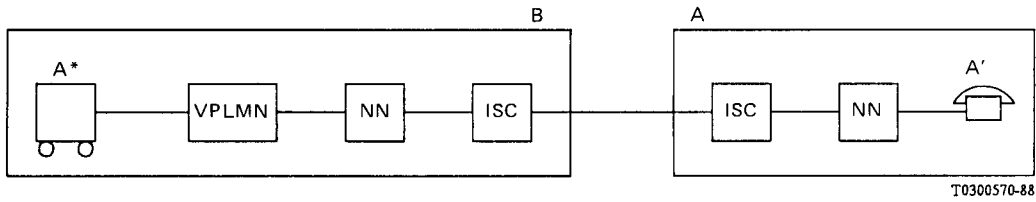

FIGURE A-3/D.93

- Charging: As for Case 2: A\* will be billed by its HPLMN based on data provided by the VPLMN.
- Inter PLMN settlement: As for Case 2: the HPLMN “A” will reimburse the VPLMN “B” for the charges incurred by the roamer.
- Traffic accounting: The call from B to A is included in the normal international telephone traffic account of B.

A.3.2 Case 3B – Call to a third country, C (see Figure A- 4/D.93)

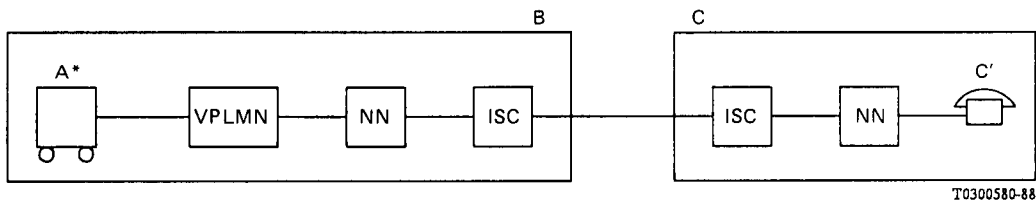

FIGURE A-4/D.93

- Charging: As for Case 2: A\* will be billed by its HPLMN based on data provided by the VPLMN.
- Inter PLMN settlement: As for Case 2: the HPLMN “A” will reimburse the VPLMN “B” for the charges incurred by the roamer.
- Traffic accounting: The call from B to C is included in the normal telephone traffic account of B.

A.4 Case 4 – Fixed station to mobile station

Fixed station A’ makes an international call to mobile station B\* in country B (home PLMN) (see Figure A-5/D.93).

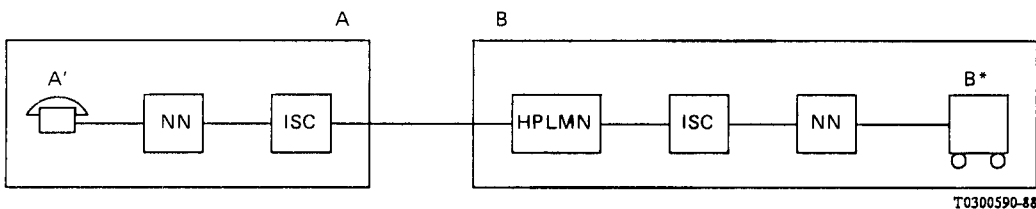

FIGURE A-5/D.93

- Charging: Appropriate fixed station to fixed station international telephone charges apply.
- Inter PLMN settlement: Not applicable.
- Traffic accounting: The call from A to B is included in A’s outgoing traffic account.

A.5 Case 5 – Fixed station to roamed mobile station

Fixed station A' calls mobile station A\* which has roamed to country B.

A.5.1 Case 5A – A' is provided with a recorded announcement saying A\* is not available on this PLMN, call is not forwarded (see Figure A-6/D.93).

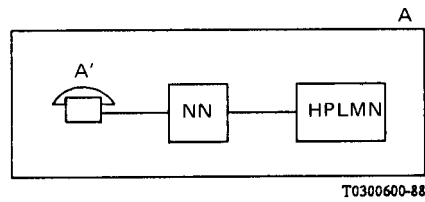

FIGURE A-6/D.93

Charging: The fixed station may be charged for accessing the recorded announcement.

Inter PLMN settlement: Not applicable.

Traffic accounting: Not applicable.

A.5.2 Case 5B – The call is automatically forwarded to the mobile network in country B. A' is not made aware (see Figure A- 7/D.93).

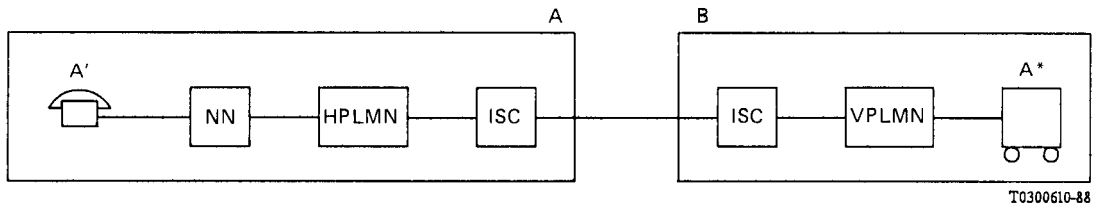

FIGURE A-7/D.93

Charging: – Fixed station is charged for the national call dialled.  
 – The HPLMN “A” may raise a charge against A\* for the forwarded element of the call.  
 – A\* may be billed by its HPLMN for charges which may be raised by the VPLMN provided for the roamer's use of its network to receive the call, based on the data by the VPLMN “B”.

Inter PLMN settlement: As for Case 2: the HPLMN “A” will reimburse the VPLMN “B” for the charges incurred by the roamer.

Traffic accounting: The call from A to B is included in A's outgoing traffic account.

A.5.3 Case 5C – Fixed station advised that the mobile station has roamed and given option of completing call at appropriate charge or cancelling (see Figure A-8/D.93).

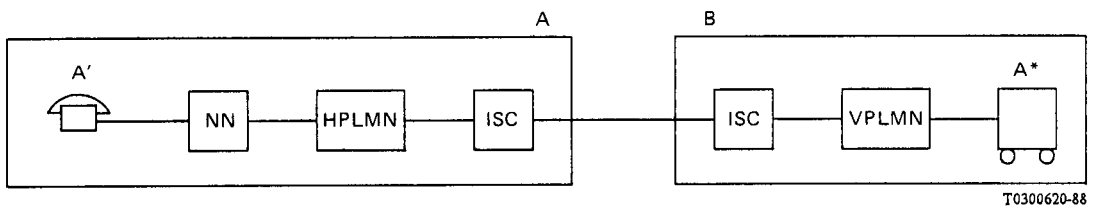

FIGURE A-8/D.93

Comment – Not yet technically possible – for further study.

A.5.4 Case 5D – Fixed station knows the roamer's temporary number in VPLMN (see Figure-A-9/D.93).

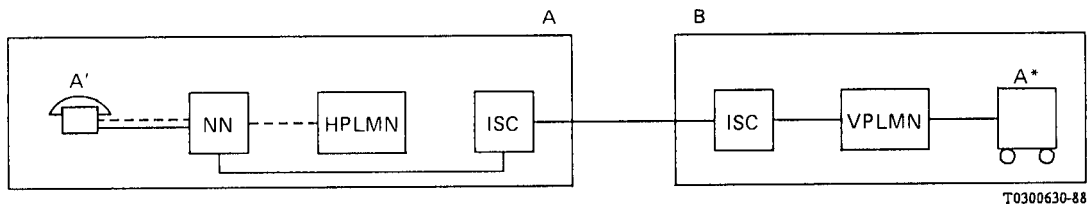

FIGURE A-9/D.93

- Charging: – As for case 4: appropriate fixed station to fixed station international telephone charges apply.
- A\* may be billed by its HPLMN for charges which may be raised by the “B” for the roamer's use of its network to receive the call, based on the provided by the VPLMN.
- VPLMN data
- Inter PLMN settlement: As for case 2: the HPLMN “A” will reimburse the VPLMN “B” for the charges incurred by the roamer.
- Traffic accounting: As for case 4: the call from A to B is included in A's outgoing traffic account.

A.6 Case 6 – Fixed station to roamed mobile station

Fixed station B’ makes an international call to mobile A\* in country A which has roamed to country B. B’ is not made aware.

A.6.1 Case 6A – Call is automatically forwarded to country B (see Figure A-10/D.93)

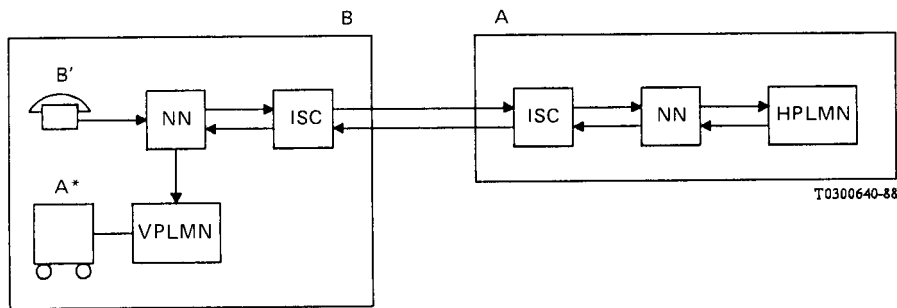

FIGURE A-10/D.93

- Charging: – As for case 5B: fixed station is charged for the international call dialled.
- The HPLMN may raise a charge against A\* for the forwarded element of the call.
- A\* may be billed by its HPLMN for charges which may be raised by the “B” for the roamer's use of its network to receive the call, based on the provided by the VPLMN.
- VPLMN data
- Inter PLMN settlement: As for case 2: the HPLMN “A” will reimburse the VPLMN “B” for the charges incurred by the roamer.
- Traffic accounting: – The call from B to A is included in B's outgoing traffic account.



- The call from A to B is included in A's outgoing traffic account.

A.6.2 Case 6B – Fixed station B' knows roamed station A\*'s temporary number in country B (see Figure A-11/D.93)

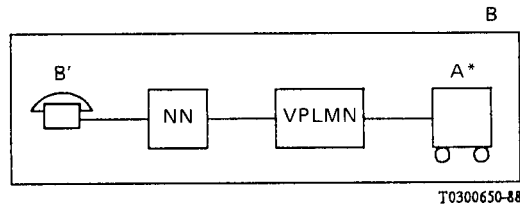

FIGURE A-11/D.93

Charging:

- As for case 4: appropriate national telephone charges apply.
- A\* may be billed by its HPLMN for charges which may be raised by the VPLMN “B” for the roamer's use of its network to receive the call, based on the data provided by the VPLMN.

Inter PLMN settlement:

As for case 2: the HPLMN “A” will reimburse the VPLMN “B” for the charges incurred by the roamer.

Traffic accounting:

Not applicable.

A.6.3 Case 6C – Using Signalling System No. 7, the mobile switching centre in country A signals to the national network (NN) in B that A\* is now in country B and the call is automatically forwarded via the mobile switching centre in country B (see Figure A-12/D.93).

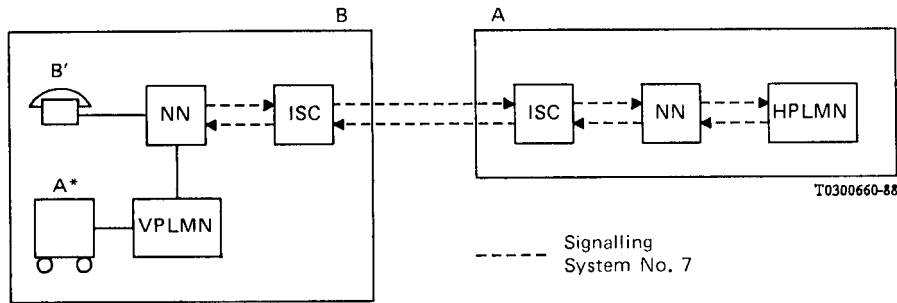

FIGURE A-12/D.93

Comment – Not yet technically possible – for further study.

A.7 Case 7 – Fixed station to roamed mobile station

Fixed station A' calls mobile station B\* which has roamed to country C. A' is not aware.

A.7.1 Case 7A – Call is automatically forwarded to country C (see Figure A-13/D.93).

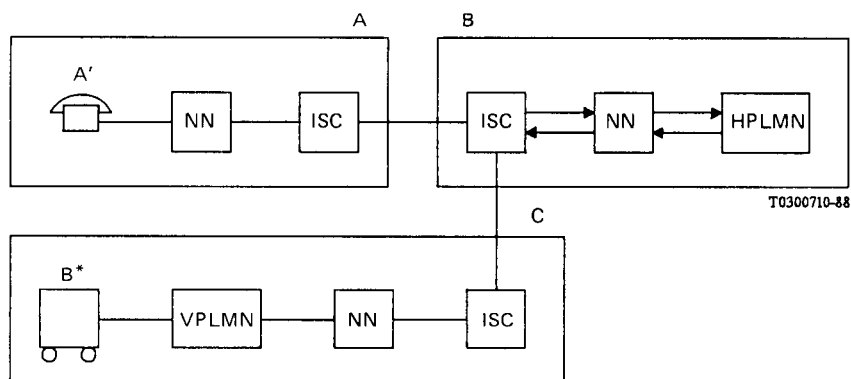

FIGURE A-13/D.93

- Charging:
- As for case 6A: fixed station is charged for the international call dialled.
  - HPLMN “B” may raise a charge against B\* for the forwarded element of the call.
  - B\* may be billed by its HPLMN for charges which may be raised by the VPLMN for the roamer's use of its network to receive the call, based on the data provided by the VPLMN.
- Inter PLMN settlement: as for case 2: The HPLMN “B” will reimburse the VPLMN “C” for the charges incurred by the roamer.
- Traffic accounting:
- The call from A to B is included in A's outgoing traffic account.
  - The call from B to C is included in B's outgoing traffic account.

A.7.2 Case 7B – Using C7, the MSC/NN in country B signals to NN that B\* is now in country C. Call is automatically forwarded to PLMN in country C (see Figure A-14/D.93).

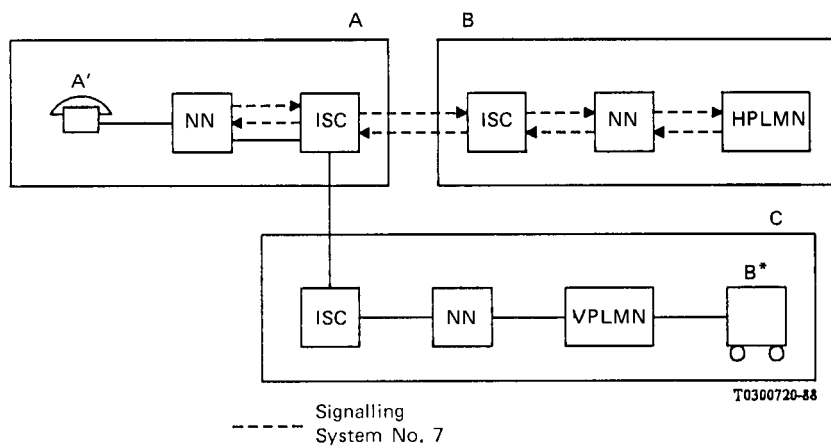

FIGURE A-14/D.93

Comment – Not yet technically possible – for further study.

A.8 Case 8 – Mobile station to mobile station

In this case the mobile station A\* is in its HPLMN and makes an international (non-roaming) call to mobile station B\* its home PLMN (see Figure A-15/D.93).

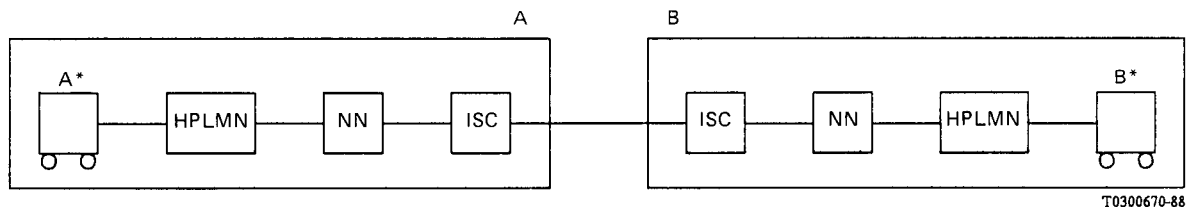

FIGURE A-15/D.93

- Charging: A\* will be billed by its HPLMN for call to country B.
- Inter PLMN settlement: Not applicable.
- Traffic accounting: The call from A to B is included in A's outgoing traffic account.

A.9 Case 9 – Mobile station to roamed mobile station

In this case mobile station A\* is in its HPLMN and makes a call to mobile station B\* which has roamed to country C (see Figure A-16/D.93).

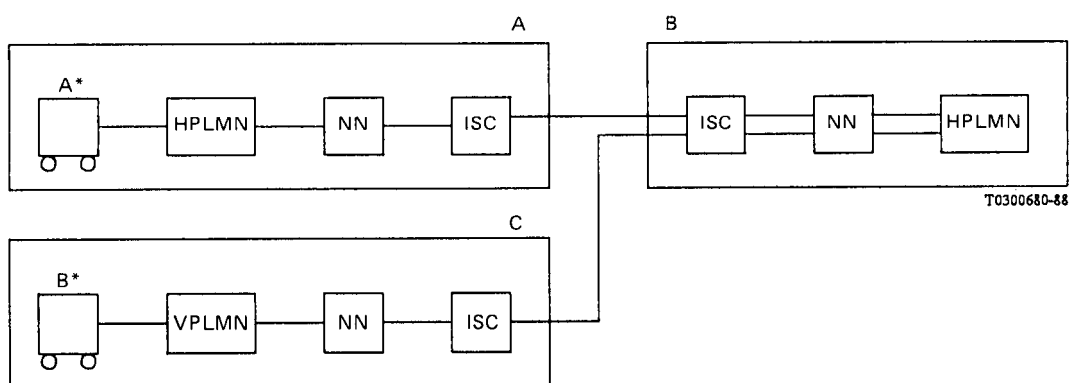

FIGURE A-16/D.93

- Charging:
- Mobile station A\* is charged for the international call dialled.
  - B\*'s HPLMN may raise a charge for the forwarded element of the call.
  - B\* may be billed by its HPLMN for charges which may be raised by the VPLMN "C" for the roamer's use of its network to receive the call, based on the data provided by the VPLMN.
- Inter PLMN settlement: The HPLMN "B" will reimburse the VPLMN "C" for the charges incurred by the roamer.
- Traffic accounting:
- The call from A to B is included in A's outgoing traffic account.
  - The call from B to C is included in B's outgoing traffic account.

A.10 Case 10 – Roamed mobile station to mobile station

In this case roamed mobile station A\* has roamed to a PLMN in country B and makes an international call to mobile C\* operating in its HPLMN (see Figure A-17/D.93).

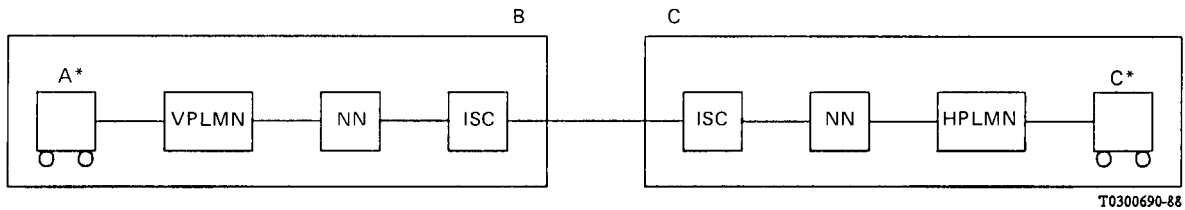

FIGURE A-17/D.93

Charging: A\* will be billed by its HPLMN based on data provided by the VPLMN.

Inter PLMN settlement: The HPLMN "A" will reimburse the VPLMN "B" for the charges incurred by the roamer.

Traffic accounting: The call from B to C is included in the normal international telephone traffic account of B.

A.11 Case 11 – Roamed mobile station to roamed mobile station

In this case roamed mobile station A\* makes an international call to roamed mobile station C\* operating in country D (see Figure A-18/D.93).

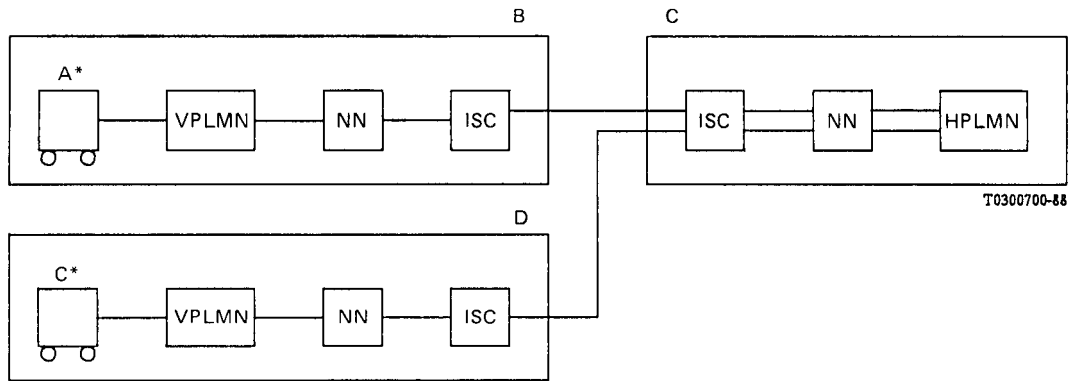

FIGURE A-18/D.93

Charging: A\* will be billed by the HPLMN based on data provided by the VPLMN.

Inter PLMN settlement:

- For A\*, its HPLMN will reimburse the VPLMN "B" for charges incurred by A\*'s roaming in country B.
- For C\*, its HPLMN may raise a charge for the forwarded element of the call.
- C\* may be billed by its HPLMN for the charges which may be raised by the VPLMN "D" for the roamer's use of its network to receive the call, based on the data provided by the VPLMN.

Traffic accounting:

- The call from B to C is included in B's outgoing traffic account.
- The call from C to D is included in C's outgoing traffic account.

**Reference**

[1] *Final Acts of the World Administrative Telegraph and Telephone Conference, Telegraph Regulations, Telephone Regulations*, ITU, Geneva, 1973. (See also the Preliminary Note No. 3, page XIV.)