



INTERNATIONAL TELECOMMUNICATION UNION

ITU-T

TELECOMMUNICATION
STANDARDIZATION SECTOR
OF ITU

Series D

Supplement 3

(03/93)

SERIES D: GENERAL TARIFF PRINCIPLES

Supplement 3:

**Handbook on the methodology for determining
costs and establishing national tariffs**

Supplement 3 to
ITU-T Series D Recommendations

(Previously CCITT Recommendations)

ITU-T D-SERIES RECOMMENDATIONS

GENERAL TARIFF PRINCIPLES

TERMS AND DEFINITIONS	D.0
GENERAL TARIFF PRINCIPLES	D.1–D.299
Private leased telecommunication facilities	D.1–D.9
Tariff principles applying to data communication services over dedicated public data networks	D.10–D.39
Charging and accounting in the international public telegram service	D.40–D.44
Charging and accounting in the international telex service	D.45–D.49
Charging and accounting in the international facsimile service	D.60–D.69
Charging and accounting in the international videotex service	D.70–D.79
Charging and accounting in the international phototelegraph service	D.76–D.79
Charging and accounting in the mobile services	D.80–D.89
Charging and accounting in the international telephone service	D.90–D.99
Drawing up and exchange of international telephone and telex accounts	D.100–D.159
International sound- and television-programme transmissions	D.160–D.179
Charging and accounting for international satellite services	D.180–D.184
Transmission of monthly international accounting information	D.185–D.189
Service and privilege telecommunications	D.190–D.191
Settlement of international telecommunication balances of accounts	D.192–D.195
Charging and accounting principles for international telecommunication services provided over the ISDN	D.196–D.209
Charging and accounting principles for universal personal telecommunication	D.210–D.279
Charging and accounting principles for intelligent network supported services	D.280–D.284
RECOMMENDATIONS FOR REGIONAL APPLICATION	D.285–D.299
Recommendations applicable in Europe and the Mediterranean Basin	D.300–D.699
Recommendations applicable in Latin America	D.300–D.399
Recommendations applicable in Asia and Oceania	D.400–D.499
Recommendations applicable to the African Region	D.500–D.599
	D.600–D.699

For further details, please refer to ITU-T List of Recommendations.

SUPPLEMENT 3 SERIES D

**HANDBOOK ON THE METHODOLOGY FOR DETERMINING COSTS AND
ESTABLISHING NATIONAL TARIFFS**

Source

Supplement 3 to ITU-T Series D Recommendations was revised by ITU-T Study Group III (1988-1993) and was approved by the WTSC (Helsinki, 1-12 March, 1993).

FOREWORD

ITU (International Telecommunication Union) is the United Nations Specialized Agency in the field of telecommunications. The ITU Telecommunication Standardization Sector (ITU-T) is a permanent organ of the ITU. The ITU-T is responsible for studying technical, operating and tariff questions and issuing Recommendations on them with a view to standardizing telecommunications on a worldwide basis.

The World Telecommunication Standardization Conference (WTSC), which meets every four years, establishes the topics for study by the ITU-T Study Groups which, in their turn, produce Recommendations on these topics.

The approval of Recommendations by the Members of the ITU-T is covered by the procedure laid down in WTSC Resolution No. 1 (Helsinki, March 1-12, 1993).

In some areas of information technology which fall within ITU-T's purview, the necessary standards are prepared on a collaborative basis with ISO and IEC.

NOTE

In this Recommendation, the expression "Administration" is used for conciseness to indicate both a telecommunication administration and a recognized operating agency.

© ITU 1996

All rights reserved. No part of this publication may be reproduced or utilized in any form or by any means, electronic or mechanical, including photocopying and microfilm, without permission in writing from the ITU.

CONTENTS

	Page
1.1 General.....	1
1.2 Purpose of determining tariffs	1
1.2.1 Cost tariffs	1
1.2.2 Public tariffs	1
1.3 Objectives to be achieved	1
1.4 Development of a costing model	1
2.1 Introduction.....	2
2.1.1 The model adopted	2
2.1.2 What is being proposed	2
2.2 Description of the model.....	2
2.2.1 The production process.....	2
2.2.2 Characterization of the cost centres (Technical aspect).....	4
2.2.3 Example of a technical aspect (Local switching, telephone).....	5
2.2.4 Characteristics of the profit centres	5
2.3 How the model works	5
3.1.1 Cost centres.....	8
3.1.2 Profit centres.....	8
3.2 Cost centres.....	8
3.2.1 Subscriber terminal equipment – telex service.....	8
3.2.2 Subscriber terminal equipment – telephone service.....	9
3.2.3 Local network	9
3.2.4 Local switching – telephone service.....	10
3.2.5 Local switching – telex service.....	11
3.2.6 "Local network" telephone service charges (aggregation level – AL).....	11
3.2.7 "Local network" telex service charges (aggregation level – AL).....	12
3.2.8 Long-distance switching – telephone service.....	12
3.2.9 Long-distance switching – telex service.....	13
3.2.10 Long-distance transmission	13
3.3 Profit centres	14
3.3.1 Local telephone service	14
3.3.2 Local telex service	15
3.3.3 Long-distance telephone service.....	15
3.3.4 Long-distance telex service	15
3.3.5 Local leased line service.....	15
3.3.6 Long-distance leased line service	15
3.4 Allocation of indirect costs	16
4.1 Accounting data	17
4.2 Physical data	17

	Page
4.3	Reports 17
5.1	National telephone service..... 18
5.1.1	Basic objective of the national telephone tariff..... 18
5.1.2	Factors to be considered when establishing tariffs..... 18
5.1.3	Design of a national telephone tariff 22
5.1.4	Main characteristics of different charging systems 23
5.1.5	Aspects of call metering 25
5.1.6	Time-of-day charging (off-peak tariffs)..... 25
5.1.7	Subscriber classification (business/residential mix)..... 26
5.2	National telex service..... 27
5.2.1	Tariff structure..... 27
5.2.2	Charging systems..... 28
5.2.3	Charging unit 28
5.2.4	Examples of national charging structures..... 29
5.2.5	Application of tariffs for different network configurations..... 29
5.2.6	Special facilities..... 30
5.2.7	Miscellaneous services/charges..... 30
5.3	Private leased circuit service..... 31
5.3.1	Definition..... 31
5.3.2	General principles..... 31
5.3.3	Tariff structure..... 31
5.3.4	Initial charges and subscriber rentals..... 31
5.3.5	Utilization charges..... 32
6.1	Useful life 33
6.2	Time-value factor..... 33
6.3	Maintenance and operating costs in relation to investment..... 34
6.4	Sample breakdown of initial investment between basic national telephone services.. 35
6.5	Allowance for the consumption of telecommunication services 35
	Chapter 7 – Conclusions 36

**HANDBOOK ON THE METHODOLOGY FOR DETERMINING COSTS AND
ESTABLISHING NATIONAL TARIFFS**

(revised in 1993)

CHAPTER 1 – INTRODUCTION

1.1 General

The purpose of this handbook is to reply to Question 29/III (Determination of costs and establishment of tariffs) which the VIIIth CCITT Plenary Assembly entrusted to Study Group III. The study relates to the telephone and telex services and private leased circuits services.

1.2 Purpose of determining tariffs

1.2.1 Cost tariffs

As for any other service or product, the establishment of a tariff, i.e. a sales price, for telecommunication services hinges first and foremost on a knowledge of the costs involved, i.e. the cost price. As is often the case in production processes which involve a large number of products, the allocation of costs to telecommunication service products inevitably raises problems since the different services (local, long-distance¹ and international telephone and telex traffic) at one time or another use the same infrastructures.

1.2.2 Public tariffs

Once the cost components are known, tariffs can be established on the basis of a number of factors of an economic, political or even social nature. Any decision concerning tariffs must seek to secure the highest possible optimisation of the infrastructure.

1.3 Objectives to be achieved

It is for the management to decide in advance on the objectives to be achieved when establishing tariffs. Except in special circumstances, one of the main objectives must be to ensure the overall financial equilibrium of the undertaking over a sufficiently long period and to generate a reasonable surplus for financing subsequent development.

1.4 Development of a costing model

The complexity of the data involved makes it necessary to develop a model that can be automated.

¹ The definition of local and long-distance network may differ from country to country.

CHAPTER 2 – DETERMINATION OF COSTS: PROPOSED MODEL

2.1 Introduction

2.1.1 The model adopted

Whatever model for costing services is adopted, it will bring with it the problem of defining cost and profit centres as a difficulty at both the theoretical formulation and application levels.

On the other hand, considering the great volume of information that would have to be used to obtain the desired results, it would be wise to adopt a model that could be entirely automated.

This would be a costing system for non-accounting items that will require no more than the basic information available in the companies to be put into operation.

This means that it will be possible to put the model to immediate use in the companies, seeing that no innovations for obtaining information will be required. The information already available as input for the model will just have to be organized in order to obtain the required reports.

2.1.2 What is being proposed

The proposal is to achieve a model for studying the cost of the telephone service, the telex service and the leased line service at national level.

On the other hand, knowledge of the costs of each service will help to establish a more consistent tariff policy, as well as to provide companies with alternatives for investments.

The management of each company will, of course, decide what other reports, in addition to those mentioned above, they consider necessary for making the best analysis of the performance of each service.

2.2 Description of the model

2.2.1 The production process

Knowledge of the production process and the quantity of input used at each stage of this process is vital if one is to determine the cost of a particular product/service.

Let us consider, for example, the case of the provision of local and long-distance automatic subscriber telephony services.

Figure 1 shows the evolution of calls through the installation and equipment involved. We can see that at some points the two services use the same installations and equipment; this occurs with the subscriber terminal equipment, the local network and local switching.

Thus, in the process of a local call, we can identify the "activities" of the subscriber terminal equipment, the local network and the local switching; and in a long-distance call, in addition to these activities, long-distance transmission and switching.

With regard to the leased line service, Figure 2 shows the facilities assigned to the leased line service. We can see that the local and long-distance leased line service do not use the switching facilities. We can also see that the local and long-distance leased line service use "similar facilities in the local network. In addition to the local network, a long-distance leased line service also uses the long-distance transmission facilities."

Considering the smallest unit of activity by which costs are accumulated as cost centres, it would seem reasonable to structure cost centres at the level of the modules that constitute the

telecommunications network. In order to reach the total cost per service, we would then need to establish cost centres for the company's other activities which are not directly linked to the production processes of the services (indirect expenses) such as: Commercialization of Services, General Administration, Instruction, Training, etc.

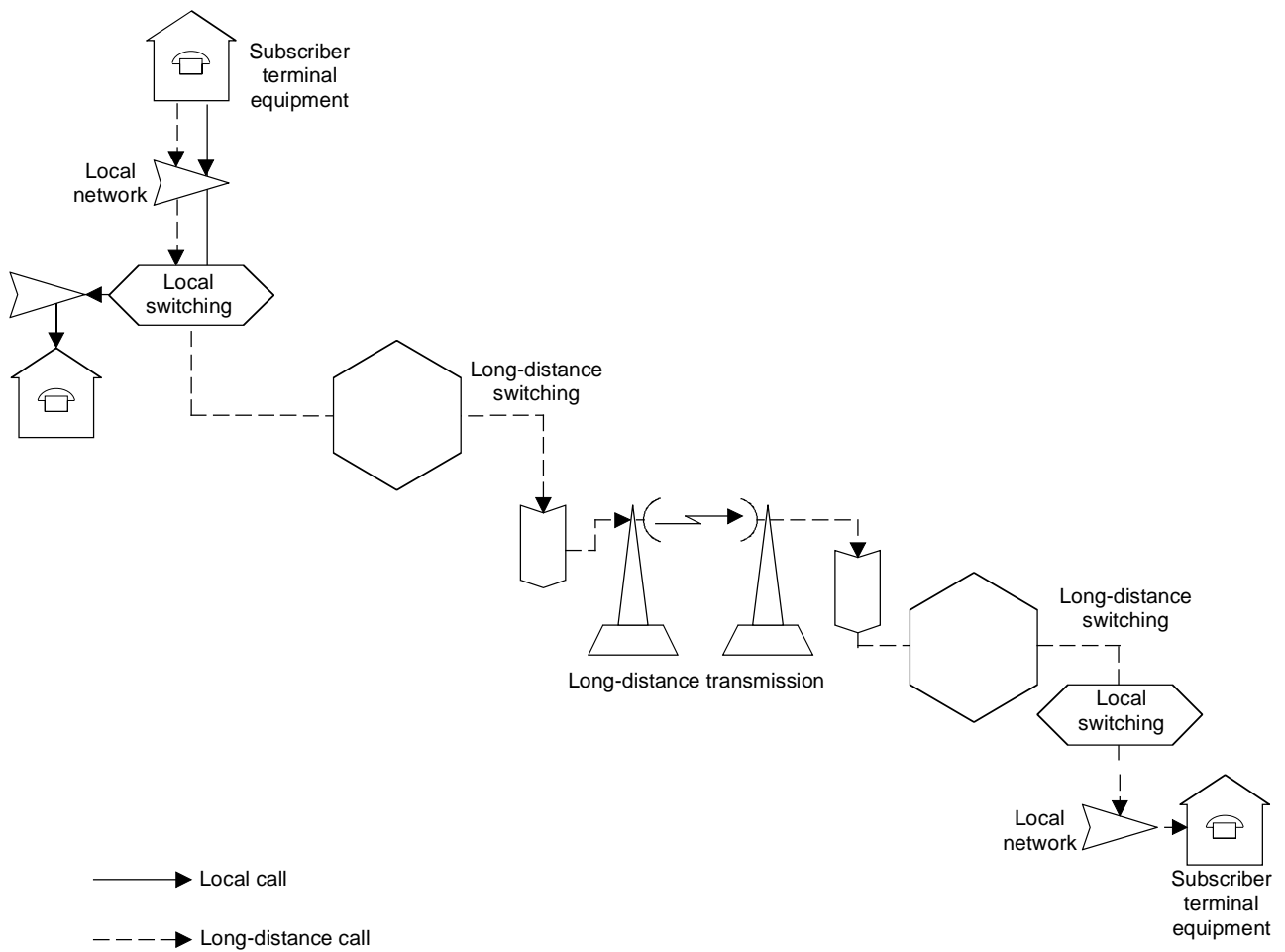

T0301450-96

FIGURE 1
The production process

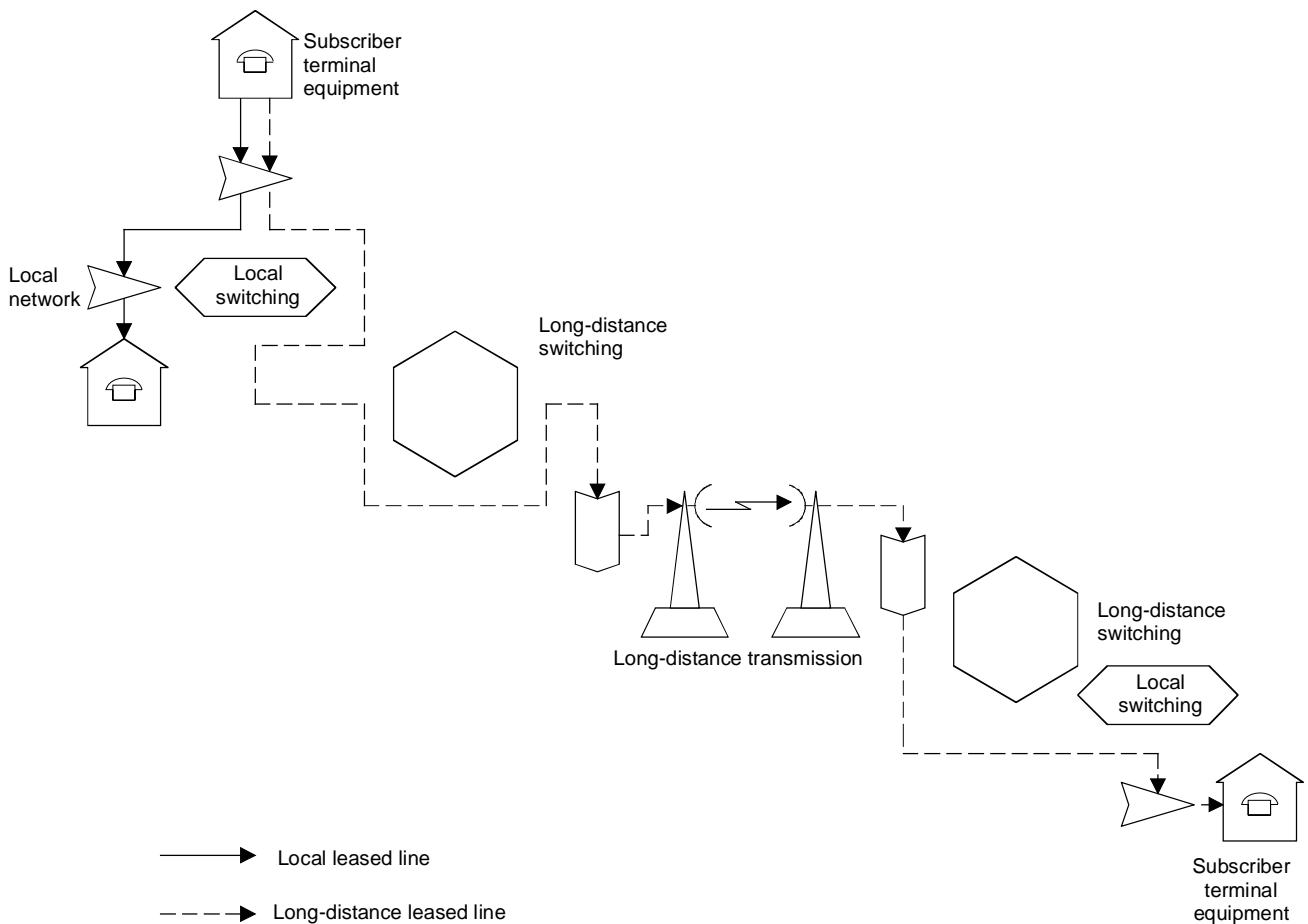

T0300830-91

FIGURE 2

The production process (leased line service)

2.2.2 Characterization of the cost centres (Technical aspect)

Each cost centre has the following characteristics:

- a) Direct costs – These are the costs of each centre which include:
 - manpower;
 - material/equipment;
 - logistics (energy, rentals, etc.);
 - contracted works;
 - financial charges and amortization;
 - others.
- b) Indirect costs – These are the common service costs which will be allocated on the basis of proportion used.
- c) Acquired costs – These are the direct and indirect costs that derive from the utilization of service units from any other cost centre.

Therefore, the total costs of a cost centre would be as follows:

$$\text{Total costs} = \text{Direct costs} + \text{Indirect costs} + \text{Acquired costs.}$$

2.2.3 Example of a technical aspect (Local switching, telephone)

Let us go back to the diagram of the production process of local and long-distance subscriber calls and let us take for example the local switching cost centre.

According to what has been established above, this cost centre would be defined as follows:

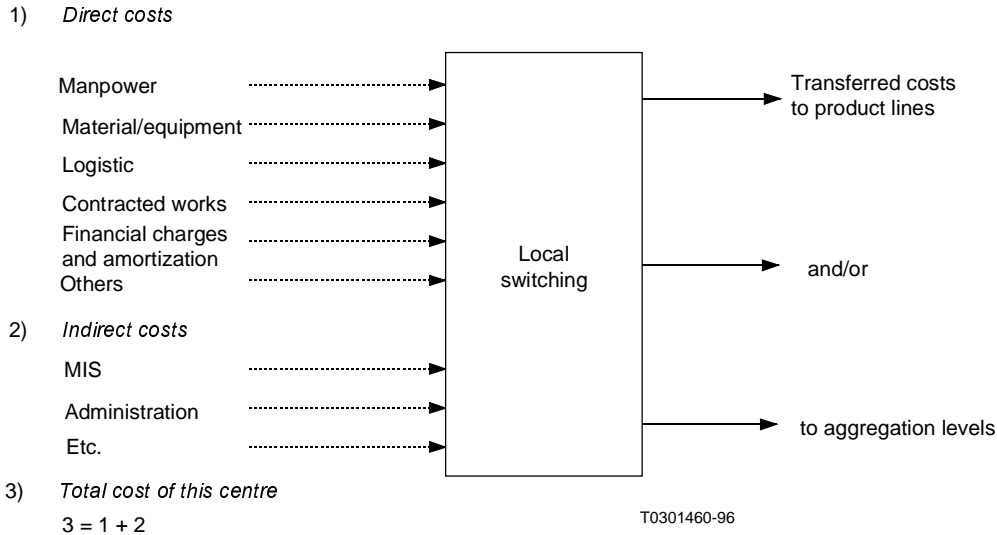

MIS = Managerial Information System

NOTE – Total cost: 3 = 1 + 2: all costs given on the technical aspect are calculated on product lines and/or aggregation levels.

The total cost of local switching consists of its direct costs, the cost of the service units it "consumes" from the local network plus the indirect costs (administration, etc.).

On the other hand, local switching transfers to long-distance switching the cost of the units (minutes/pulses) that are placed at the disposal of the long-distance service; it transfers to the local service the cost of minutes/pulses placed at the disposal of the users of this service.

2.2.4 Characteristics of the profit centres

Profit centres correspond to services commercialized by the Administration/ROA.

Their costs are only produced by an apportionment of technical aspect costs.

In order to make the apportionment process more readable (or to ease the reckoning) it will be allowed to gather technical aspects costs into aggregation level within "profit centre" level, the distinction between direct costs and indirect costs does not work, instead of the notion of "nature" (e.g. manpower, amortization, etc.) has a full meaning.

2.3 How the model works

Supposing that a telecommunication company provides local and long-distance automatic subscriber-to-subscriber telephone and telex service and also provides local and long-distance end-to-end leased line service, the model proposed here would work in the manner shown in Figure 3.

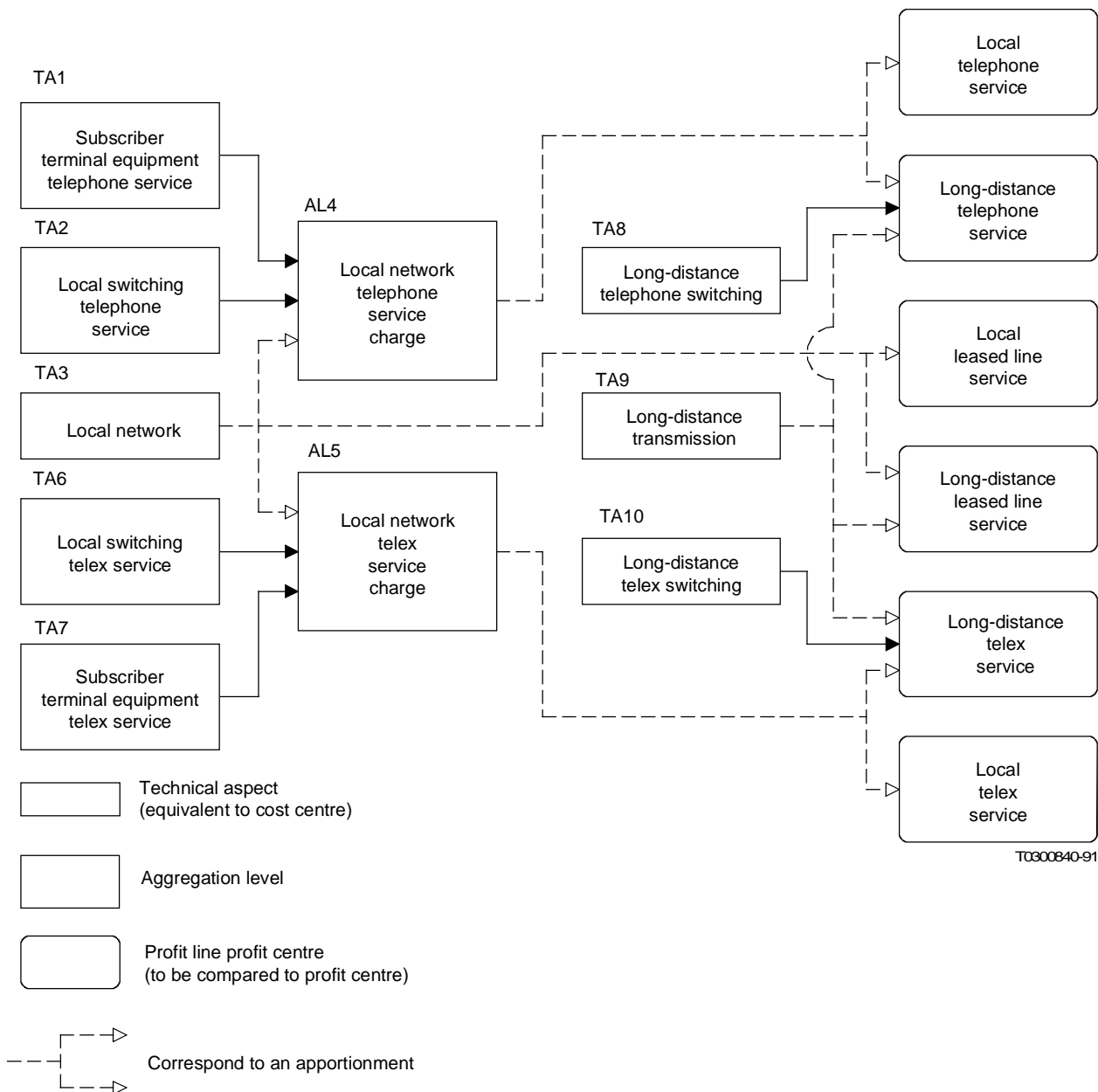

FIGURE 3
Articulation of the model

In the process of generation of costs, the articulation of the cost centre reflects the correct allocation of costs which does not necessarily represent the physical sequence of "activity" carried out in the production services.

The proposed model presents the following information:

- the total value of the service being provided;
- the value of the traffic unit (minutes/pulses) being provided;
- the total cost in each cost centre;
- the cost of the service unit in each cost centre;
- costs involved in each phase of articulation.

The analysis of the total cost of the local telephone service would convey, for example, the following information:

- the total cost of the local telephone service;
- the minutes/pulses cost of the local telephone service;
- the quantity of minutes/pulses of the local telephone service;
 - the share of the following elements in the composition of these costs: manpower, materials, constructions, contracted work, financial charges and amortization, MIS, marketing, administration, etc.;
 - the origin of these total/unit costs: local switching telephone service, local network telephone service, local network and subscriber terminal equipment telephone service.

Example: Treatment of a profit centre: "Long distance traffic telex service":

The profit centre «Long distance traffic telex service» gathers charges from:

- the technical aspect (TA) long distance telex switching (i.e. international switching centre);
- a part of TA long distance transmission. The apportionment made for example from telephone circuits used for telex transmission;
- a part of the aggregation level (AL) "local network telex service"; the apportionment is made, for example, from the taxed traffic (unit: minutes).

Long-distance transmission (TA) (part).....	Long-distance traffic Telex service
Long-distance telex switching (TA)	
"Local network" telex service (AL) (part)	

CHAPTER 3 – COST AND PROFIT CENTRES

3.1 The different cost and profit centres are defined below in addition to the criteria set up for transferring costs.

3.1.1 Cost centres

- 1) Subscriber terminal equipment telex service.
- 2) Subscriber terminal equipment telephone service.
- 3) Local network.
- 4) Local switching telephone service.
- 5) Local switching telex service.
- 6) "Local network" telephone service charges (aggregation level).
- 7) "Local network" telex service charges (aggregation level).
- 8) Long-distance switching telephone service.
- 9) Long-distance telex switching.
- 10) Long-distance transmission.

3.1.2 Profit centres

- 11) Local telephone service.
- 12) Local telex service.
- 13) Long-distance telephone.
- 14) Long-distance telex service.
- 15) Local leased line service.
- 16) Long-distance leased line service.

3.2 Cost centres

3.2.1 Subscriber terminal equipment – telex service

Subscriber terminal equipment – telex service consists of:

- teleprinter;
- associated wiring and auxiliary equipment;
- other equipment and belongings.

Service unit: terminal equipment;

Cost allocation criterion: the subscriber terminal equipment transfers all its costs to the "local network" telex service charge.

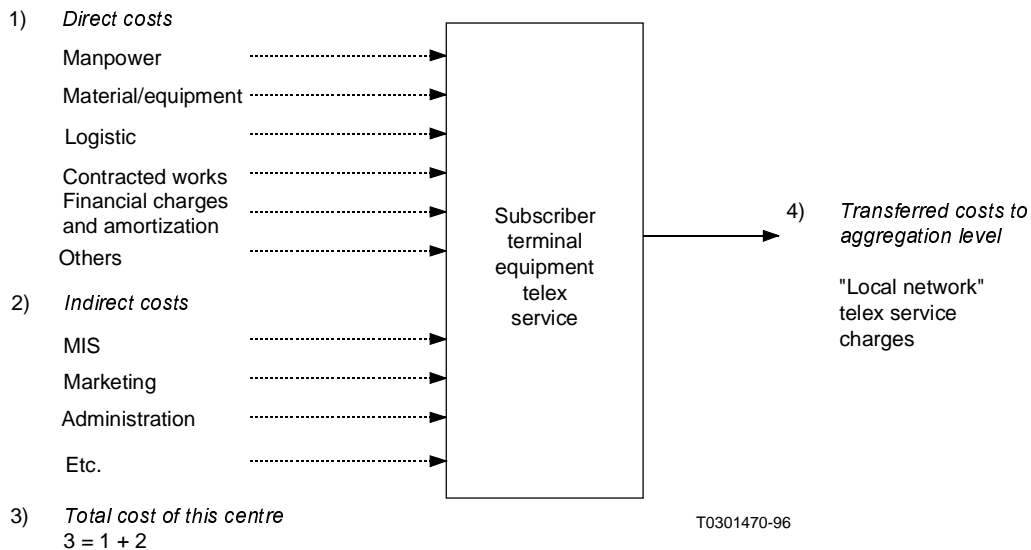

3.2.2 Subscriber terminal equipment – telephone service

Subscriber terminal equipment – telephone service consists of:

- telephone set;
- associated wiring and auxiliary equipment;
- other equipment and belongings.

Service unit: terminal equipment;

Cost allocation criterion: the subscriber terminal equipment transfers all its costs to the "local network" telephone service charges.

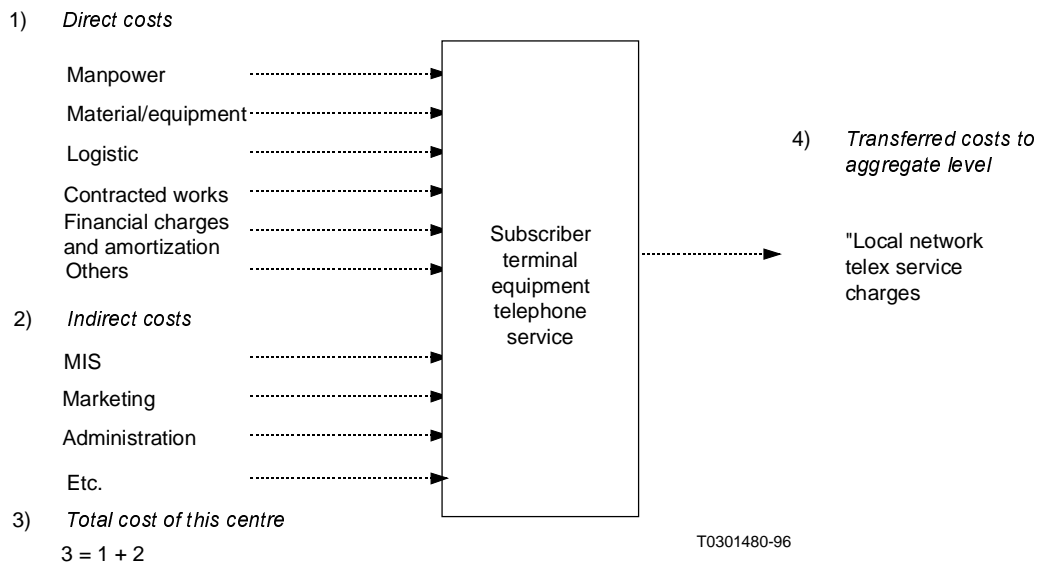

3.2.3 Local network

Local network consists of:

- open wire lines and support pylons;
- aerial cables and support pylons;
- underground cables;
- cabinets, pillars, etc.

- equipment like PCM (Pulse Code Modulation), digital microwave, single line carrier, optical, etc., used in the local network;
- other equipment and belongings.

Service unit: network facilities for interconnection between switching centres and between user terminal equipment and switching centres;

Cost allocation criterion: proportional to the service unit allocated to telephone service or telex service².

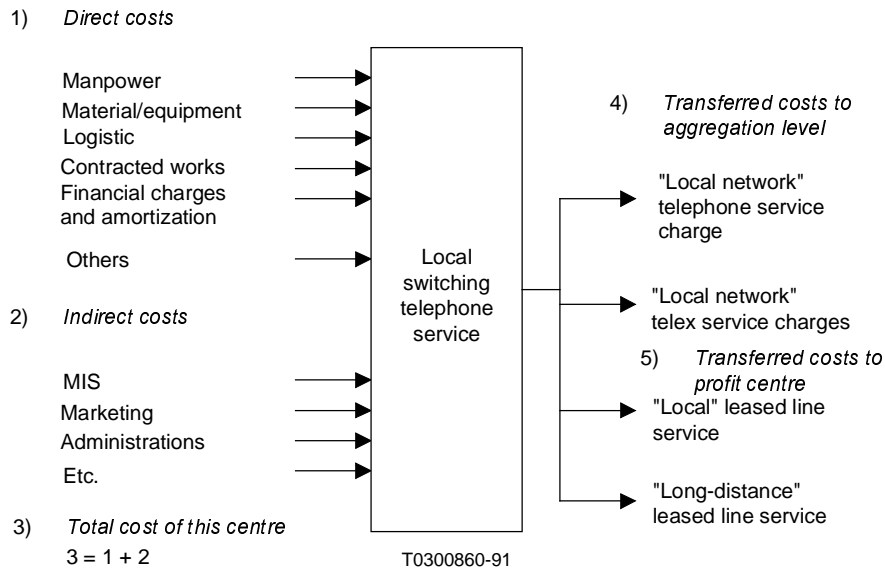

3.2.4 Local switching – telephone service

Local switching – telephone service consists of:

- manual local switching exchange;
- automatic local switching exchange;
- logistic (energy, rentals, etc.);
- power plant and air conditioning equipment;
- test and control position and equipment.
- other equipment and belongings.

Service unit: chargeable unit of traffic (minutes/pulses);

Cost allocation criterion: the local switch telephone service transfers all its costs to the "local network" telephone service charges (AL).

² The definition of the service unit and methods for cost allocation are for further study.

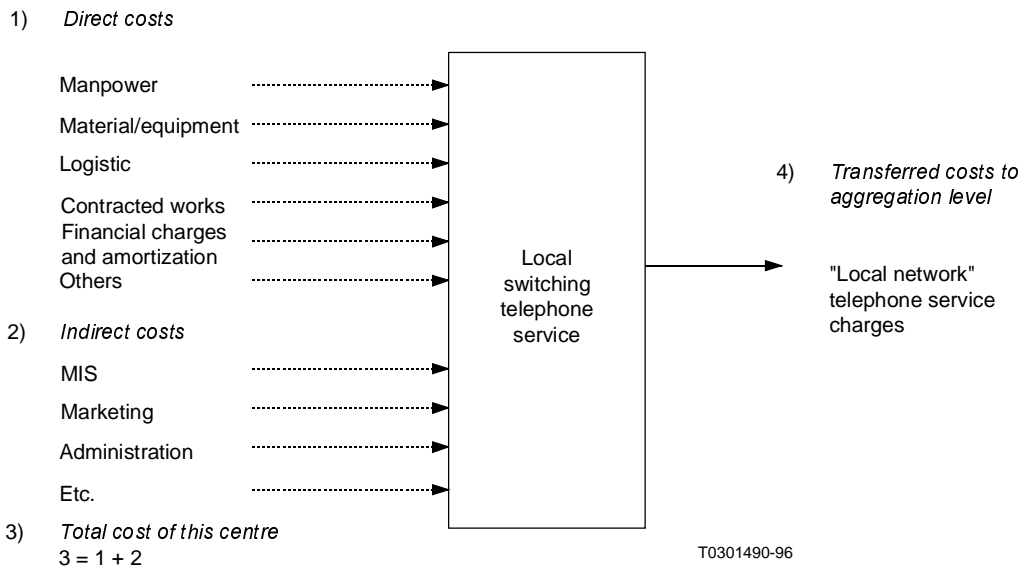

3.2.5 Local switching – telex service

Local switching – telex service consists of:

- automatic local switching exchange;
- logistic (energy, rentals, etc.);
- power plant and air-conditioning equipment;
- test and control positions and equipment.
- other equipment and belongings.

Service unit: chargeable unit of traffic (minutes/pulses);

Cost allocation criterion: the local switch telex service transfers all its costs to the "local network" telex service charges (aggregation level).

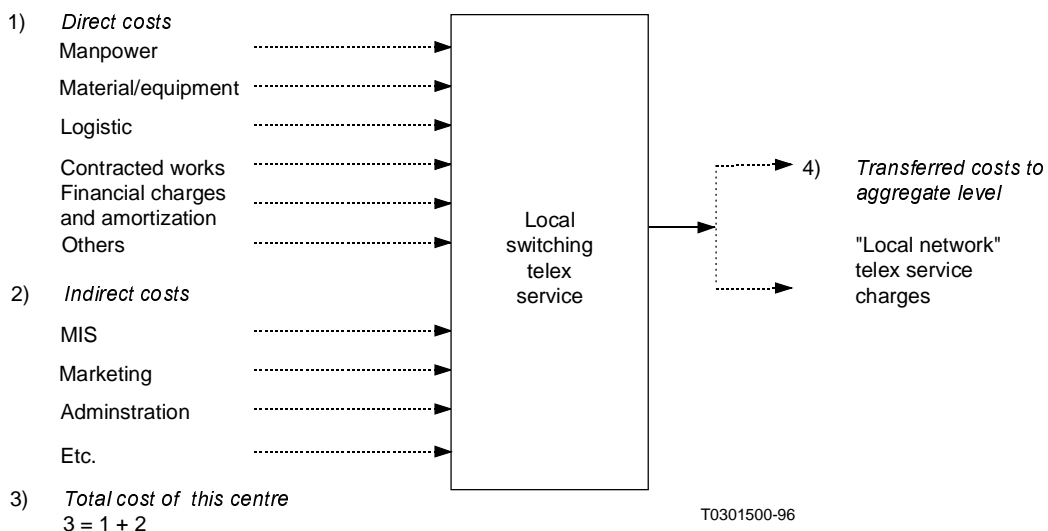

3.2.6 "Local network" telephone service charges (aggregation level – AL)

- "local network" telephone service charges;
- service unit: chargeable unit of traffic (minutes/pulses);

- cost allocation criterion:
 - a) for the local telephone service, proportional to the number of minutes/pulses allocated to the "local service" centre;
 - b) for the long-distance telephone service, proportional to the number of minutes/pulses allocated to the long-distance telephone service.

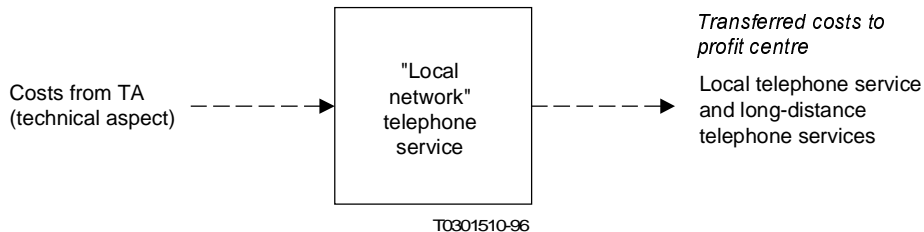

3.2.7 "Local network" telex service charges (aggregation level – AL)

- local network telex service charges;
- service unit: chargeable unit of traffic (minutes/pulses);
- cost allocation criterion:
 - a) for the local telex service, proportional to the number of minutes/pulses allocated to the "local service";
 - b) for the long-distance telex service, proportional to the number of minutes/pulses allocated to the long-distance service.

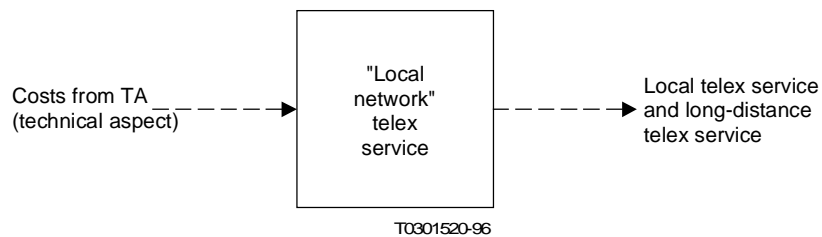

3.2.8 Long-distance switching – telephone service

Long-distance switching – telephone service consists of:

- manual and semi-automatic trunk exchange;
- trunk automatic exchange;
- logistics (energy, rentals, etc.);
- power plant and air-conditioning equipment;
- test and control position and equipment;
- other equipment and belongings.

Service unit: chargeable unit of traffic (minutes/pulses);

Cost allocation criterion: transfers all its costs to the long-distance service itself.

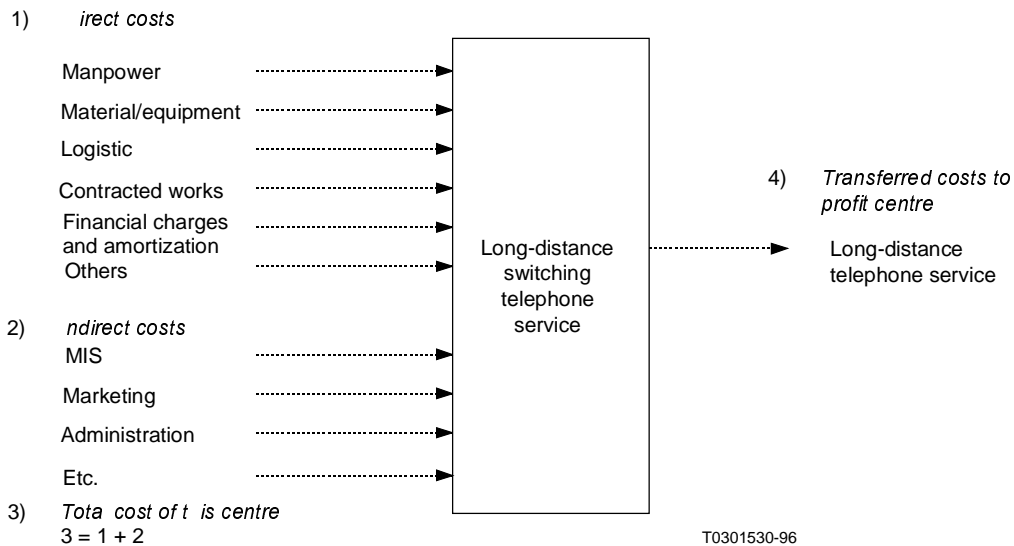

3.2.9 Long-distance switching – telex service

Long-distance switching – telex service consists of:

- automatic long distance and international switching;
- logistics (energy, rentals, etc.);
- power plant and air-conditioning equipment;
- test and control positions and equipment;
- other equipment and belongings.

Service unit: chargeable unit of traffic (minutes/pulses);

Cost allocation criterion: transfers all its costs to the long-distance telex service.

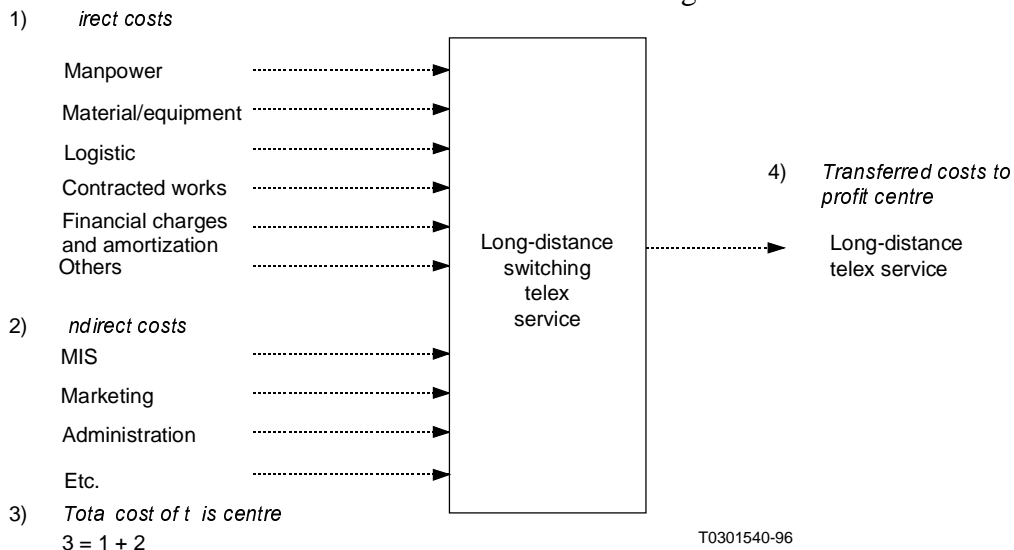

3.2.10 Long-distance transmission

Long-distance transmission consists of:

- open wire line system;
- underground cable system;
- radio based system;
- logistic, tower, repeater stations;
- satellite based system;

- optical fibre system;
- test and control positions and equipment;
- other equipment and belongings.

Service unit: voice channel;

Cost allocation criterion: for each service like telephony, telex, etc., proportional to the unit service allocated.³

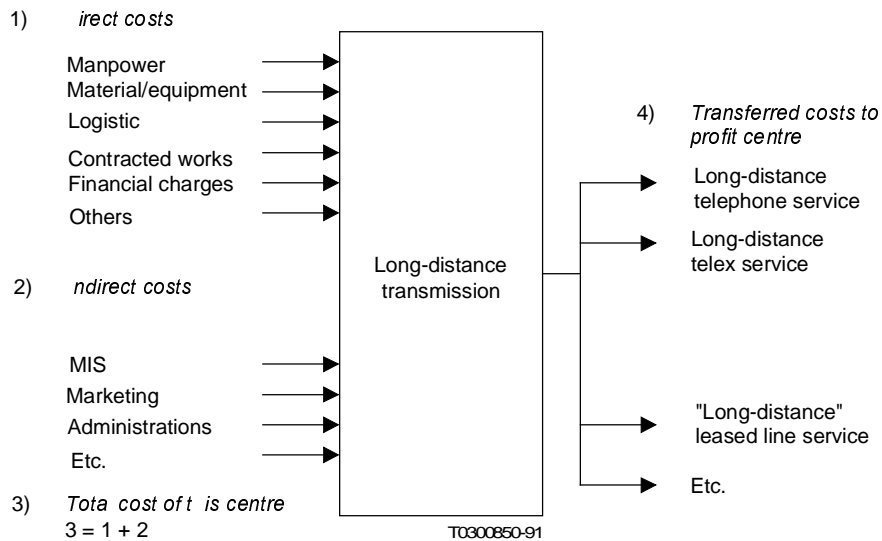

3.3 Profit centres

The following are profit centres that correspond to services provided to users.

3.3.1 Local telephone service

Service unit: minutes/pulses.

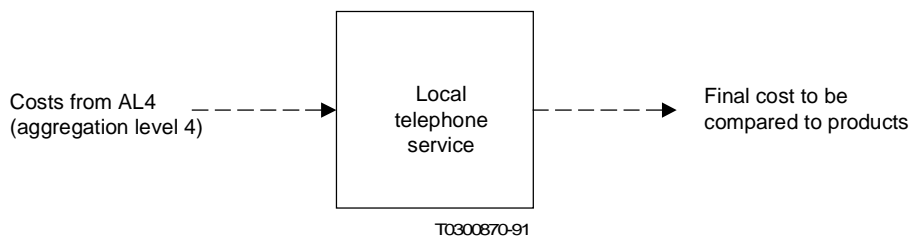

³ The definition of the service unit in a digital environment and methods for cost allocation are for further study.

3.3.2 Local telex service

Service unit: minutes/pulses.

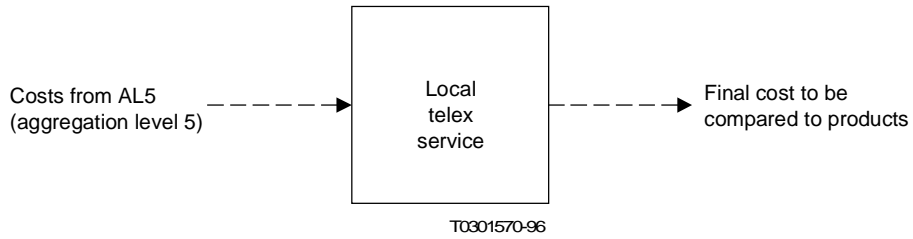

3.3.3 Long-distance telephone service

Service unit: minutes/pulses.

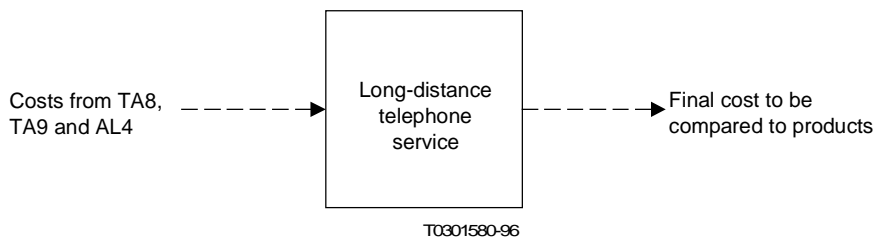

3.3.4 Long-distance telex service

Service unit: minutes/pulses.

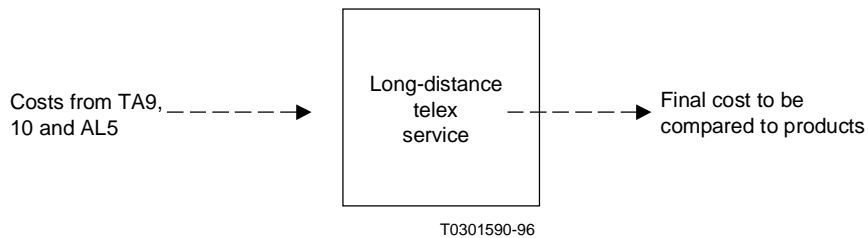

3.3.5 Local leased line service

Service unit: number of lines or capacity of lines.

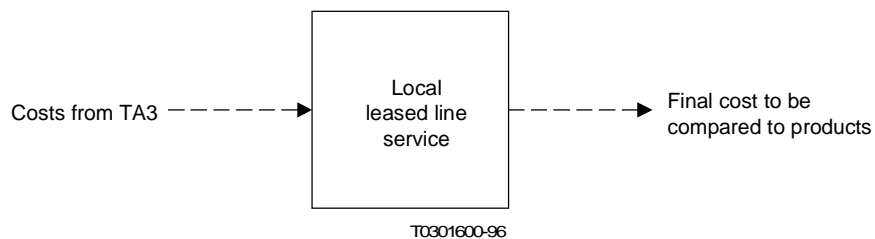

3.3.6 Long-distance leased line service

Service unit: number of lines or capacity of lines

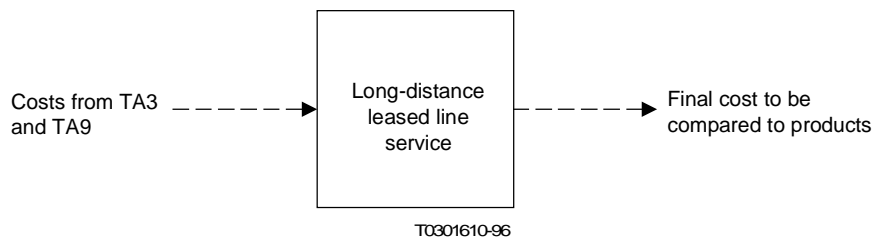

3.4 Allocation of indirect costs

Cost allocation criterion:

For each cost centre: The following allocators can be used to distribute indirect cost:

- direct cost;
- manpower;
- subscribers;
- number of lines.

For example, indirect cost of Managerial Information System (MIS) can be allocated to each cost centre by applying the direct cost allocator.

$$\text{Indirect cost of MIS} \times \frac{\text{direct costs of each cost centre}}{\text{total direct costs}}$$

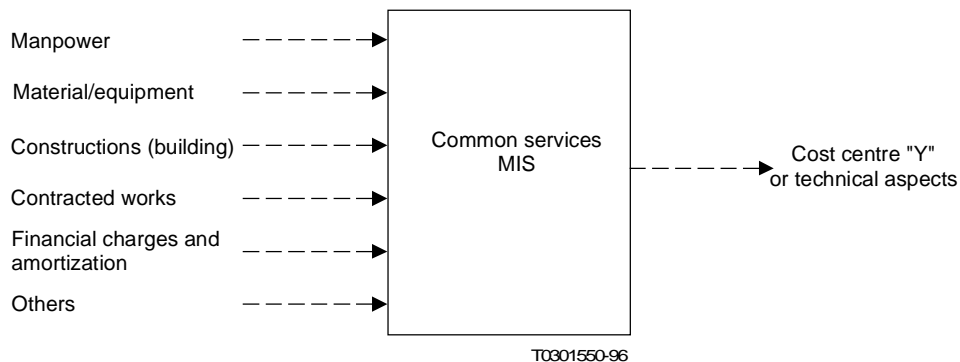

Similarly, indirect cost of administration can be allocated by applying the manpower allocator.

$$\text{Indirect cost of administration} \times \frac{\text{manpower assigned to each centre}}{\text{total manpower}}$$

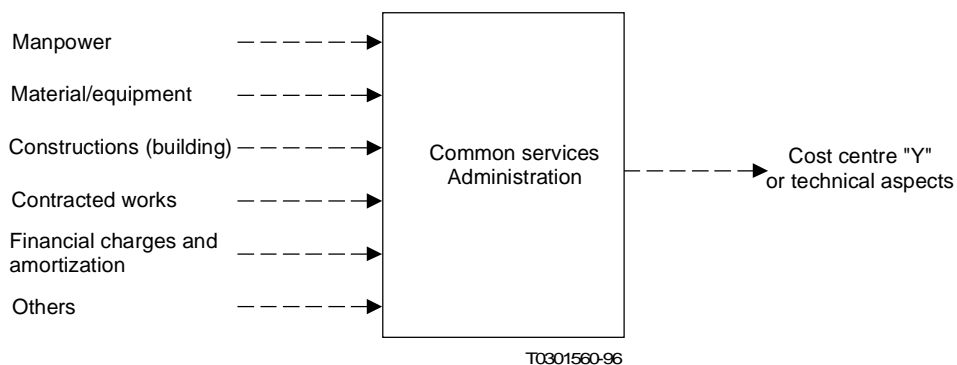

CHAPTER 4 – THE INPUT DATA FOR THE MODEL

4.1 Accounting data

As stated above, the input data for the model consists of information already available in each company which requires organization.

4.2 Physical data

The measurements of traffic now being carried out in the "ticketed" manual and automatic long-distance service are habitual.

In the local service there is no difficulty in determining the traffic being carried out. Should a particular company have any difficulty in determining traffic in localities where service is not measured, the eventual discounting of this traffic (which it is always possible to measure) will not affect the results, considering its small significance.

4.3 Reports

The model makes it possible to analyse the annual costs at the level of each service, which as compared with the revenue makes it possible to determine the margin (rate per unit).

CHAPTER 5 – ESTABLISHMENT OF TARIFFS (PUBLIC TARIFFS)

5.1 National telephone service

5.1.1 Basic objective of the national telephone tariff

5.1.1.1 In principle, the prime objective in setting charges for the national telephone system is to recover the cost of providing the service, including running costs, depreciation and a suitable return on the capital investment. The return on capital is usually that agreed with or allowed by a Regulatory Body, normally the Government. This basic principle can equitably be applied to individual components of the national telephone tariff, although in practice economic and political structures generally preclude such an absolute approach and cross-subsidy between individual components of the tariff almost invariably applies.

5.1.1.2 Fixing rates based on a pre-determined return on capital is common practice with public services – water, gas, electricity, etc., and so, unlike many other commodities, there is rarely an opportunity to benefit from a monopoly situation by raising prices above a relatively modest level of return. In some instances, it may also be necessary – due to political and social pressures and price elasticity – to fix the domestic tariff on the basis of low or even nil or negative return, with cross-subsidy from the generally more economic international services or other areas of Government revenues, e.g. oil. The national telephone tariff should incorporate all standard facilities and services which can be defined as those required on a regular basis or in sufficient demand to warrant uniform charging on a common service basis. The range of services included may therefore vary between different countries' systems but would always incorporate call charges and rentals and installation fees for exchange lines provided by the standard means of construction. Usually commonly supplied terminal apparatus such as extension telephones, PABXs, planphone arrangements and single payment services such as removals, takeover of existing services and re-connections will also be covered by the standard tariff. One-off charge assessments should apply for specialized subscriber requirements such as large PABXs (normally applying specially - assessed rental or sale formulas) or for subscriber lines provided by non-standard means or in remote areas with low demand (applying a special construction charge procedure which incorporates a specially assessed rental formula).

5.1.2 Factors to be considered when establishing tariffs

5.1.2.1 General background

- i) A variety of circumstances exist under which telecommunication systems are provided in developing countries. Countries differ from one another not only in their stage of development, but in their geography and terrain, their population size and mix, their economic and political structures and their actual and potential wealth.
- ii) In any single country, there may be a variety of needs which the Telecommunications Administration has to serve. Differences may arise between geographic regions, between urban and rural, public and private demands, business and residential groups.
- iii) In general, these are termed environmental factors under which an Administration has to operate. Other factors, generally termed marketing factors, will determine how much demand arises, how much service will be given and can be used to overcome or accentuate the environmental factors.
- iv) In this subclause, four factors are considered as follows:
 - standard of living;
 - urban and rural service considerations;

- telephone penetration level;
- elasticity of demand.

NOTE – Some of the work in this section is an extract from GAS 5 reports and further information in these areas can be obtained by reference to these ITU GAS 5 reports.

5.1.2.2 Standard of living

- i) The level and distribution of national income in a country or a market segment has a very significant impact on the demand for telecommunications services. A mathematical model has been developed which determines, amongst other parameters, the correlation of average income per household with the demand for private telephone installations. One of the objectives was to find the level of income at which half of all households desire a telephone. For the year 1965 and at a rate level prevailing in the Federal Republic of Germany it was found that at an average household income per month of approximately DM 2000 (or US \$ 550), half of all households had a telephone, or had ordered one.
- ii) The distribution of income, as well as the average level of income, may be among the determinants of the demand for a given commodity. A country with a few rich people and many poor is likely to have quite a different consumption pattern from that of a country with the same average level of income which is distributed fairly evenly. Similarly, looking at income distribution over time, a significant shift of the sort which could be caused by a radical reconstruction of tax structure might result in a substantial change in consumption patterns: middle-class purchasing habits could replace those of the rich and the poor. Within any given country, however, changes in income distribution are normally fairly gradual and will not affect consumption of most consumer products greatly except over the rather long term.
- iii) There are other possible shifts in income which are not necessarily discovered by examining average income levels and which may be of importance in determining consumer purchases. For example, some forecasters emphasize the idea of the threshold income level - that there is some level of income at which the household moves over the threshold of willingness and ability to buy some particular product or service. If the threshold income level can be identified and the number of households moving over it in any given year can be predicted, this will obviously be of help in determining the potential market for the commodity in question. A market segmentation of the residential sector by income classes can be valuable. The aim is to determine the market penetration in different segments and the probability to use the service.
- iv) As income grows, one can expect pronounced shifts in the relative demand for different categories of goods and services. Particular types of shifts have been observed by comparing the budgets of individual working-class families. A rising family income tended to be accompanied by increased spending in all categories while the percentage spent on food tended to decline, the percentage spent on housing and household operations tended to remain constant, and the percentage spent on clothing, transportation, recreation, health and education tended to increase.

5.1.2.3 Urban and rural service considerations

- i) In urban areas, there is generally a concentration of economic activity (including government service) which gives rise to a telecommunication demand. In addition, the average income is normally higher than in other parts of the country, which means that the demand for all types of goods and services is generally higher. Thus, a telecommunication demand in such areas often exceeds supply. At the same time, the costs of providing telecommunication services in these urban areas are low compared to the costs of providing services in isolated and/or

underprivileged areas. Consequently, it is usually possible for telecommunication companies to achieve a good rate of return on the services offered in urban areas.

- ii) In rural areas, on the other hand, average income is relatively low. At the same time the costs of providing telecommunication services are relatively high due to the distances that have to be covered, low population densities, and/or low levels of equipment utilization. Thus, for the greater part, subscribers are unable to pay the full cost of the service. Consequently, it is generally difficult for telecommunication companies to achieve an adequate rate of return on the services offered in these special areas.
- iii) Telecommunication development in the developing countries indicates that the limited resources normally available for investments in telecommunications have been primarily allocated to urban, interurban and international services where declining unit costs and the higher financial returns can be obtained. To the extent that these investments are restricted to the modern sector of the country's economy, their benefits do not extend directly to rural areas where many of the country's poor live and where even the basic telecommunication needs are not being met. This may, to a considerable extent, be due to the fact that investments in these areas are financially unprofitable.
- iv) One of the greatest problems facing telephony development in rural areas is the financial unattractiveness of such projects. In this regard, it is generally recognized that service provision to remote and/or underprivileged areas should not have to be entirely self-financing. Some form of internal cross-subsidy scheme is the solution most commonly recommended to deal with this problem. Cross-subsidy schemes have the advantage of being relatively easy to administer and not highly visible. Use of this technique, however, is not without its drawbacks. In particular, it results in the telecommunication authority being forced to take on a policy responsibility for which it was not intended and may not be equipped. Such a responsibility should normally lie with the national government. Such a line of reasoning would lead a country to favour some form of direct, government-sponsored, tax-based, subsidy scheme. Ultimately, each country must decide this issue for itself, given its circumstances.
- v) The issue of what form a subsidy should take does not answer the question of how much the subsidy should be. For developing countries which typically face overall capital shortages, this is a difficult question to answer. Ultimately, the answer lies in being able to demonstrate that telecommunications deserve a higher priority when scarce investment funds are being allocated.

5.1.2.4 Telephone penetration levels

- i) The relationship between households/dwellings and the provision of telephones is usually expressed in terms of penetration where 100% implies that each household has a telephone. This penetration level is usually expressed as main stations per 100 population (also termed telephone density).
- ii) Telephone penetration levels may be viewed/used in three ways:
 - a) as a measure of achievement following implementation of a telephone system and or telephone tariffs;
 - b) as a method of predicting future demand for services (usage) and arranging tariffs to encourage/discourage specified areas/times of usage;
 - c) as a means of demonstrating the need for telecommunications investment.
- iii) Actual penetration of service into households reflects a perceived need (value) for telecommunications, taking environmental and geographical consideration into account.

- iv) The cost of initial telephone acquisition and subsequent maintenance and usage is an important factor in the rate of telephone penetration. Households that are currently without service are likely to be those who are either not in a position to afford it or those who are yet to be provided with a service by their Administration. A further category may be those households who will be induced to utilize the service once it is made available in their area. The momentum of telecommunications development will therefore be dependent on established (often commercial) users. In order to promote and sustain economic growth in a country as a whole, tariff structures for telephone services should have a broad economic base that recognizes the different needs of the various sections of the community.

5.1.2.5 Elasticity of demand

- i) It is a widely known and accepted fact of economic theory that normally the higher the price of a particular product or service the less it will be demanded. This statement is modified by the concept of demand elasticity; a product is said to be price-inelastic when the relative change in demand is correspondingly smaller than the relative change in price. At the extreme, a product is highly price-elastic if revenue decreases with increasing prices; though the unit price increases, the number of units demanded falls sufficiently to yield less total revenue. It is unlikely that this would be a desirable change, though for some enterprises it might be, yielding the same profit with less effort and resources through a decrease in expenses. Usually, with price-elastic products, costs cannot be reduced in proportion and price increases lead to smaller profits, or larger losses per unit. This feature applies particularly to telephone services because of the large fixed costs existing in networks.
- ii) Price-elasticity of demand
- Elasticity of demand for new installations may be estimated taking into account the subjective price perception of potential customers. Price elasticity expresses the sensitivity of customers to the cost of the service. The elasticity parameter is calculated as the ratio of percentage change in demand (quantity sold per period) caused by a percentage change in price.

In symbols,

$$E_{qp} = \frac{\frac{Q_1 - Q_0}{Q_0}}{\frac{P_1 - P_0}{P_0}} = \frac{\text{Relative change in quantity}}{\text{Relative change in price}}$$

where:

- E_{qp} is the elasticity of quantity demanded with respect to a change in price
- Q_1 is the quantity demanded per period after price change
- Q_0 is the quantity demanded per period before price change
- P_1 is the new price
- P_0 is the old price

Elasticity of revenues (E_{RP}) may be derived from the above formula as follows:

$$E_{RP} = 1 + E_{qp}$$

- iii) Besides the application of price elasticity to new installations, an elasticity factor may be determined for the effect of a change in monthly fixed charges on subscribers' decisions to retain the service (telephone, telex, private line, etc.).

Similarly, elasticity of demand studies may be used to evaluate the effect of higher or lower usage charges on traffic volumes (e.g. local calls, long-distance calls, telex, facsimile, etc.).

The factors can be calculated by analyzing the effect of historic changes in tariffs for which related unit quantities can be identified.

In an inflationary environment it should be kept in mind that unchanged tariffs represent a relative decline in real price compared to a rising overall price index from year to year. Under a condition of price elasticity this will result in a demand stimulation.

The degree of elasticity depends on several factors. Intuitively, demand elasticity will be low for telephone business subscribers, and higher for private long-distance calls. The degree of availability of comparable substitute services (e.g. mail, telegram) also influences price elasticity. Finally, the degree of price elasticity depends on levels of income (business cost consciousness, or private disposable or discretionary income).

Elasticity is often lower with greater market penetration, and it may vary with the size of the price change. Elasticity may also be different for price increases and decreases.

5.1.3 Design of a national telephone tariff

5.1.3.1 General background

Recognizing that there may be difficulties in trying to cost relate the different tariff items, it is useful to have certain guidelines on the costs relevant to individual tariff items. They may, for example, help in countering Government or customer complaints regarding the pricing of individual items of service. It should be noted that spare capacity should always feature as part of the "averaged" costs of any service.

In general there are three basic methods of tariffing national telephone systems; that whereby all calls are charged, that where no calls are charged, and that where only some classes of calls are charged. All methods have common features and components listed below that should be identified and costed individually. These costings can then be incorporated into the tariffing/charge setting procedure in a manner suitable to the tariff system under study.

5.1.3.2 System where all domestic calls are chargeable

i) *Exchange line rental*

The charge for this item should, on a cost related basis, be designed to service the average cost of all apparatus that is *exclusive* to each subscriber, i.e.: cost of the telephone instrument, installed cost of the line from exchange to subscriber's distribution point and of exclusive equipment in the public exchange such as the subscriber's meter together with maintenance of all these items.

ii) *Exchange line installation fee*

This item should, on a cost related basis, cover average capital cost of the drop wire from the distribution point to the subscriber's premises, plus all wiring within the premises and the labour and transport cost involved in making the connection, including connection of the telephone instrument.

iii) *Domestic call charges*

The charges for domestic calls should, on a cost related basis, service the cost of public exchange (less any exclusive equipment therein) plus inter-exchange links.

It may be possible to segregate local and trunk call costs (normally by breakdown of exchange and trunk costs on a traffic weighting basis). In practice however, this may be unnecessary because the general tariff strategy will be for a certain style of tariff,

(e.g.: untimed local calls plus a range of different metering intervals on the different classes of trunk call), thereby precluding precise cost relationship for each different type of call.

iv) *Terminal apparatus – (rentals and installation fees)*

Tariffs for standard range PBXs, extension telephones and other terminal apparatus are normally easier to cost-relate than the preceding items because identification of average cost is more straightforward/easier.

v) *Deviation from cost related approach*

The main restrictions on applying a cost related approach for each separate tariff item are political, social, marketing and strategic. The cost factors usually indicate that the exchange line rental applied to "residential" customers should be higher than that applied to "business" customers. This is because the average exchange to subscriber line length is greater to residential areas than to business areas. Also, there may be a short term benefit in maintaining low residential rentals if this means that spare capacity is reduced but longer term planning should be based on more cost-related rentals for all classes of subscribers.

However, the rentals actually applied may well have to represent the opposite of this fact if the service provision policy is to provide residential subscribers with an affordable service. Likewise, the inability to market the residential service at a cost-related rental would support a "below cost" approach.

In practice, the domestic tariff affords considerable opportunity for a desirable degree of "cross subsidy". Terminal apparatus like PBXs, plan arrangements and answer-phones and essentially business-oriented services and can usually sustain premium charges. Call charges could be at a premium level due to the preponderance of business-originated traffic. Exchange line installation fees represent the main example of "strategy-based" charging; the charge could be at or above the cost where demand exceeds capacity. This approach has the additional advantage of not affecting existing customers.

The principal dangers inherent in having a heavy business to residential subsidization are residential dilution of the system, unrequired new residential demand (particularly in remote rural areas) and restriction in business demand (e.g.: for replacement of aging facilities).

5.1.3.3 Flat-rate system

i) Under this system the rental level(s) allows for specified classes of call to be made regardless of volume, without payment of any traffic-related charges. In geographically large systems, this "free" usage may be restricted to local area calls but for a small system the rental may incorporate system-wide usage.

ii) A strictly cost-related approach therefore requires incorporation of average subscriber usage in the rental and, quite contrary to the above arguments, a consequent excess in the business rental because of the higher usage usually made by business subscribers.

The approach to pricing of exchange line installation fees and terminal apparatus charges should generally be the same as for a "call charging" system.

5.1.4 Main characteristics of different charging systems

5.1.4.1 Flat rate

No call charges for calls within a specified geographical area; this may cover the *whole* of the domestic system.

Characteristics

i) Easy and simple to apply; the subscriber knows exactly what their bill will be and billing complaints are therefore avoided. Revenue and cash flow estimating is simplified.

- ii) Inescapable "high" rentals which effectively penalize low usage subscribers and therefore could discourage subscriber demand. The business/residential rental differential takes no account of the wide variation of usage within each classification. Usage tends to be high because no call charges are payable often resulting in high exchange and trunk route costs.
- iii) There is no need to supply subscriber's meters or call timing equipment (unless International Subscriber Dialling on a bulk billing basis is introduced).
- iv) Where tariff changes are required, there is little option but to amend the flat rental(s) due to the lack of other major revenue sources, so there is minimal flexibility.

5.1.4.2 Partial flat rate (specified number of calls or call units at nil charge)

Usage may be stimulated but it is usual that many subscribers will restrict their usage to the amount allowed for free or only make essential calls.

5.1.4.3 Message rate (metered untimed call)

Calls to or within a specified geographical area are charged at a fixed amount regardless of duration.

Characteristics

- i) Complaints regarding call bills are less likely than with a measured call system and revenue forecasting is less complicated but in that respect both systems suffer compared with flat rate.
- ii) Subscribers can make long duration calls reasonably cheaply. This increases or expedites the requirement for additional equipment, including expensive trunk circuitry resulting in additional costs.
- iii) Because calls are charged at a common rate *per call* there may be a cost saving on equipment, there being no need for periodic pulse metering.

5.1.4.4 Measured rate

Calls are chargeable on a measured basis, i.e.: based on distance, duration and possibly time of day.

Characteristics

- i) The billing is relatively more complicated; there are more meter reading complaints than on flat or message rate, whilst the revenue forecasting is complicated.
- ii) The subscriber is able to control to a considerable degree the size of their bill for telephone service through limiting the number and/or duration of their calls. This makes the measured rate system capable of justification in principle to subscribers and controls the level of expenditure on exchanges and trunk equipment and circuitry.
- iii) The timing of all calls means that the basic charges (exchange line rental and the unit call fee) can be maintained at a lower level than with message rate or flat rate thus encouraging more subscriber demand. Message rate and flat rate encourage long duration calls, yielding no additional revenue and creating a requirement for additional switching equipment but measured rate yields call revenue in proportion to system usage. This means that any additional expenditure required on switching equipment will probably be offset by an increase in call revenue.
- iv) Additional capital cost is initially required to provide subscribers' meters and pulse generating equipment. A measured rate system is particularly compatible with the introduction of International Subscriber Dialling.
- v) This system gives the greatest degree of selectivity when considering tariff amendments.

NOTE – The different characteristics of each charging approach can in fact often be construed, as far as the Administration is concerned, as either advantageous or disadvantageous. For example, under 5.1.4.4 (Measured rate) the encouraging of demand from applicants with low potential usage is generally undesirable as a long-term proposition since it creates pressure for investment on uneconomic expansion but in circumstances where considerable spare capacity exists, even low rental/low usage subscribers may be economically worth encouraging as a short-term policy. Similarly under the flat rate method the high fixed charge(s) may limit demand – this may be beneficial to the Administration depending on similar considerations.

Without such an approach, the result may well be tariffs which achieve the short-term revenue requirements for the overall business but which may effect heavy business to residential subsidy, stimulating excessive residential demand, diluting the system and requiring an inordinate level of new investment.

5.1.5 Aspects of call metering

5.1.5.1 Periodic Pulse Metering (PPM)

This is the most common method of metering subscribers calls, whereby the equipment registers an initial meter pulse (representing one unit call fee) as soon as the destination telephone is answered and then registers one pulse at every fixed interval thereafter. The initial chargeable pulse represents payment for "setting-up" cost and subsequent pulses represent payment for circuit and exchange occupancy.

5.1.5.2 Repeat multi-metering

This method is the same as with PPM except that multiple pulsing applies on answer and at every fixed interval thereafter, e.g. 2 units on answer and then 2 more units at, for example, every 3 minutes thereafter.

5.1.5.3 Local/trunk call metering

Most measured rate telephone systems apply PPM on variable pulse intervals which are dependent on distance or zone. Local area calls (defined as own-exchange calls, calls within a specified multi-exchange area or calls within a specified geographical area) might be charged at call unit fee for unlimited time (i.e.: on answer only) with only trunk (non-local) calls charged on PPM, often at varying pulse intervals depending on distance or time of day. The increasing tendency is to move towards periodic pulsing of all calls whether with local calls less frequently pulsed than trunk calls or in geographically small systems, with uniform pulsing for all domestic calls.

5.1.6 Time-of-day charging (off-peak tariffs)

5.1.6.1 Longer duration pulsing intervals may be desirable on calls made during evening and weekend periods to increase demand in the periods when switch/trunk capacity is under employed and to relieve traffic loading during the busy business period. However, if there is no or little congestion in the busy parts of the day and insignificant "new demand" is expected there is a risk that overall call revenue will actually reduce, with no offsetting benefit from decongestion.

5.1.6.2 When considering the introduction of off-peak rates care must be taken in evaluating what is trying to be achieved, i.e.:

- is the aim to try to transfer a part of the peak hour traffic during normal working days to another time of the day to achieve a more even and efficient utilization of the network; i.e. cost saving approach; or
- is the aim to encourage subscribers to make additional calls and thus create additional revenue.

5.1.6.3 If traffic is dominated by commercial and administrative type traffic, this traffic is unlikely to be transferred to non-office hours or be very responsive to reduced charges. In such cases, reduced

non-office hours traffic would not relieve congestion during the peak periods but only mean that calls which would have been passed will be passed at lower charges and thus reduce income.

5.1.6.4 Another problem could be that the peak hour for traffic will be changed by the introduction of reduced rates and the peak hour thus transferred to the reduced rate period. This is uneconomic as the system will normally be dimensioned on the basis of traffic on which a reduced earning is received. Care must be taken in identifying the hours during which reduced off-peak rates apply and to retain the flexibility to adjust these hours in the light of experience.

Ideally, off-peak rates should not be offered on operator-handled calls (because operator costs invariably increase outside normal working hours) or to a destination where the time difference is too great.

These points are also valid in studying the question of the introduction (implementation) of different collection charges for different days of the week.

5.1.7 Subscriber classification (business/residential mix)

5.1.7.1 With respect to availability and usage of the telephone system, the business and residential users can generally be regarded as distinct sectors. National tariff structures generally reflect this categorization and apply a higher tariff for business users than for residential users. Whilst this approach is often not consistent with the costs arising (reflecting a degree of cross-subsidy between the market sectors), this tariff differential is often supported by the greater usage made of the system, and the ability to pay, of the business sector.

5.1.7.2 This interaction between business and residential tariff levels offers an opportunity to Administrations to influence demand in accordance with their service provision policy (e.g. to provide subscribers with an affordable residential service) or perhaps to restrict demand in light of capacity constraints.

5.1.7.3 In this context it should be noted that factors affecting the demand for telephone service differ for each sector of the market (e.g. the business sector will be more influenced by the economic/business activity level, the availability of substitute services, etc.) and the effect of a price change can be difficult to estimate accurately. Accordingly, it is prudent to obtain some measure of the effect of any price change or customers usage/demand and this may require the analysis of average customer calling patterns between the market sectors before and after a price change.

5.1.7.4 Residential customer bills

Residential customer bills are relatively straightforward in that they usually cover only the exchange line rental and call charges. Records of customer calling patterns can be used to identify the effect of charges in call prices, to be added to any rental adjustments. However, some customers will make fewer calls and their bills will comprise a higher proportion of rental than for the average customer. This will not be of any significance if the proportional increases are the same for rentals and call charges. However, with the trend of costs tending to require greater rental increases, the proportional increase in bills is greatest for those customers making least calls. These may be customers who can least afford increases. Figures derived from average bills should therefore be quoted in terms of the average effect.

5.1.7.5 Business customer bills

An average of all business customer bills has limited value except as an indicator of the mean of a wide range of variables, and for comparison on the same basis with the average residential bill. As business customers vary in their usage of the service it is advisable to build up case histories of various categories of business customer so that the effect on each, and on demand, can be identified in more general terms.

5.2 National telex service

5.2.1 Tariff structure

In general, there should be three main types of charges for the telex service:

- i) An initial installation fee, for having a connection to the network which is paid prior to the initial connection being made.
- ii) A subscription charge which may be paid periodically, i.e. monthly, quarterly, etc., in advance to cover the telex equipment and connection to the telex exchange (private wire). In some countries the provision of telex equipment has been deregulated and private companies or subscribers may provide their own equipment. In such cases a lower connection to the service charge may be applied.
- iii) Traffic charges, that is the charge for the utilization of the network.

5.2.1.1 Initial fees and subscription charges

- i) The initial fees and subscription charges for a telex subscription should at least cover the average costs, which are independent of the traffic exchanged. These costs are:
 - a) amortization and interest on the capital which is invested by the Administration in the individual equipment of each subscriber (e.g.: teleprinter, subscriber's line, line relays, meter, relevant part of exchange building, etc.);
 - b) current maintenance of the individual equipment of each subscriber and other operational costs (e.g.: the entry of the subscriber's name, address and telex number in the telex directory, the costs of the necessary subscription registers, the costs of production and handling of the bills, etc.).
- ii) The purpose of the initial fee plus the subscription charges is to cover these basic costs which occur even if the subscriber does not use his equipment for outgoing communications.
- iii) There is an interdependence between the initial fee and the subscription charge, the higher the initial fee is set, the lower the subscription charge can be and the inverse is also true. The lowest initial fee should correspond to the costs of the labour used, materials consumed, and the Administration involved for the installation of the subscription. The initial fee is an important marketing tool which can be used as a demand regulator for the service. The reasons for fixing the initial fee at a higher level may be that a prohibitive effect is desired, i.e.: the Administration wants to reduce the demand, because of shortage of investment or other resources, or it may be that large receipts are needed in a short time in order to finance current investments or to fulfil contracted loan repayments.
- iv) The ideal situation is when an Administration has the possibility to determine the initial fee at an optimum level, which results in the meeting of desired revenue and cash flow targets whilst not deterring the public from making applications for new subscriptions.

5.2.1.2 Traffic charges

- i) The traffic charge is a fee for each communication which should cover any remaining costs of capital plus the operation of the network concerned especially the switching equipment.
- ii) For local communications this fee usually varies according to the duration, that is, it is fixed per unit of duration with one minute or six second units being the most commonly used.
- iii) For long distance communications, the communication fee may vary both according to the duration and to the geographical distance between the subscribers involved. This basis is also common practice for international service.

5.2.2 Charging systems

5.2.2.1 For manual and semi-automatic networks, the registering and subsequent debiting of call charges is initiated by the operator who established the call. When the subscriber books the call and after the call is finished, the operator records on a "ticket" all the relevant details which are:

- the calling subscriber's name and category;
- the called subscriber's name and category;
- the time and date;
- the tariff to be applied;
- the call duration.

These tickets are then processed to produce customers bills.

5.2.2.2 When telex service is provided on an automatic network, two different methods can be used for automatically debiting call charges against the originating subscribers. These are:

- periodic pulse metering;
- automatic ticketing.

The two methods can be used together in the same telex network.

5.2.2.3 Periodic Pulse Metering (PPM)

Periodic pulse metering is a system whereby charging pulses are generated and counted during a call by a meter which is connected to the individual line circuit equipment of each subscriber. The subscriber meter is stepped by the pulses and the pulse frequency is determined by the tariff. It is common that the pulse interval is inversely related to the distance between the two subscribers.

5.2.2.4 Automatic ticketing

In this method, all necessary information for charging a call such as the calling subscribers number and category, the called subscribers number and category, the time and date, the tariff to be applied and the duration of the call, are automatically stored on a ticket, perforated tape or magnetic tape. For billing purposes these tickets or tapes are subsequently processed in a processing centre.

5.2.3 Charging unit

5.2.3.1 It has become common practice for different minimum charging units to be applied depending on the type of service offered.

5.2.3.2 For fully automatic service:

- i) charging is by the minute and any fractions of a minute shall be charged as for one minute. This is known as one plus one; or
- ii) charging is by shorter periods (commonly six seconds) either derived by periodic pulse metering or an automatic accounting system.

5.2.3.3 For semi-automatic and manual service:

- i) any telex call of three minutes duration or less is normally charged as for three minutes;
- ii) when the duration exceeds three minutes, a charge shall be made for each minute in excess of the first three minutes. Any fraction of a minute shall be charged as for one minute. This is known as three plus one.

5.2.4 Examples of national charging structures

5.2.4.1 The national telex network configuration will depend on the size of the country, the number of current and potential telex subscribers, their geographic distribution, the economic situation of the country, the stage of development of the telecommunications Administration, etc. This configuration will shape the charging structure and levels, especially for the traffic charge.

5.2.4.2 The following different configurations are considered:

- i) The country is served with one telex exchange which works as combined national/international exchange.

The telex exchange is usually installed in the capital of the country where there is a concentration of business. Subscribers outside the capital are connected through long distance lines.

In some towns outside the capital where there is an identified concentration of business, line concentrators may be installed. These line concentrators may be connected to the telex exchange using VFT or TDM channels.

- ii) In a large country with a higher number of subscribers and several towns where business is concentrated, the country is usually served with several telex exchanges connected together in a system hierarchy (which may be more or less analogous to the hierarchy in a telephone network) with the main exchange often working as a combined national and international exchange.

5.2.5 Application of tariffs for different network configurations

Considering the different network configurations the following may be concluded:

5.2.5.1 A country with one telex exchange

- i) Remote subscribers are connected by long-distance lines.
- ii) Remote subscribers are connected to line concentrators.

Whichever of these apply, both the initial fee and the subscription charge may be increased in proportion to the cost of the long-distance line – pertaining to the subscriber – and the line concentrator. However, it may be desirable to have a standard "universal" subscription charge with subscribers a long-distance from the exchange in effect being subsidized by those only a short distance from the exchange.

To simplify the subscription charge it can be divided into two parts: one relating to the apparatus (teleprinter) and the other to the line (and accessories).

The traffic charge should, however, ideally be the same for local and remote subscribers, thus it does not vary by distance as the transmission and switching costs will be the same for all calls.

5.2.5.2 A country with several telex exchanges

In a country with several telex exchanges forming a hierarchy in the national telex network, the tariff ideally would be as follows:

For local subscribers, that is subscribers connected to the same telex exchange, either in the capital of the country or in any other town, the charges paid by the subscribers will be an installation fee, subscription fee and the traffic charge. Ideally, all local calls on all exchanges would be at the same rate, but for non-local, i.e. "trunk" or "national" calls there should be different traffic charges that are distance related. The scheme of distance steps in telex should be less complex than that usually found in telephony, as the biggest part of the cost is related to switching equipment and not to trunk lines as is the case in telephony. Two or three steps of distance can be used.

The long distance charges should be calculated to cover the costs of transit exchanges, trunk lines, transmission equipment, maintenance and operation costs, administrative costs, etc.

5.2.6 Special facilities

Many modern telex exchanges have special facilities such as abbreviated dialling, message broadcasting, store and forward, etc. Subscribers wishing to be connected to such facilities may have to pay a certain charge, for each facility to be paid periodically with the subscription charges. It may be difficult to fix the level of such charges, but it should at least cover any extra costs resulting from such facilities but to evaluate these charges more satisfactorily, a thorough marketing study of the demand for such facilities and real value of such service is necessary. In certain cases they may be considered enhancements to the basic service, which will increase usage of this service and will be provided free of charge.

5.2.6.1 Store and forward

Subscribers are able to store messages within the exchange for subsequent transmission. Generally, no additional charge is made for this facility.

5.2.6.2 Multi-address call

The same message can be sent simultaneously to a number of different destinations. Each message should be charged for a separate message.

5.2.6.3 Abbreviated dialling

An initial list of numbers is normally provided free of charge. Any subsequent changes to the list will be subject to a charge to cover the cost of a new programme.

5.2.6.4 Automatic call transfer

Incoming calls for one number may be transferred to another local number during the absence of the subscriber from the first number. No additional charge is normally made for this facility.

5.2.6.5 Automatic advice of duration

The advice of duration of a telex call will be automatically printed out on completion of all calls. No charge is made for this facility.

5.2.6.6 Subdivided accounts

Available to subscribers who require their telex account to be subdivided into sections. No additional charge is normally made for this facility.

5.2.6.7 Conference call

Permits "conversations" to be held between the caller and a number of other numbers, which may include an overseas subscriber. Each connection is charged for as a separate message.

5.2.7 Miscellaneous services/charges

5.2.7.1 Teleprinter transfer charge

A charge should be paid by any subscriber who wants to transfer their teleprinter from its installed place to another. The charge should cover all the costs incorporated in such a transfer. Average transfer charges can be set for:

- transfer within the same building;
- transfer outside the building;
- transfer outside the town.

A transfer charge is paid once against the execution of such transfer.

5.2.7.2 Deposit

Some Administrations ask for a deposit which is paid at the beginning of a subscription with the initial fees. This deposit can be against any damage that may happen due to misuse of the teleprinter, or if there is doubt about the financial status of the customer. The deposit can include a certain amount equivalent to the average consumption of a subscriber for the billing period. The deposit is reimbursed to the subscriber at the time his contract is concluded.

5.2.7.3 Recovery of equipment

A charge shall be paid by any subscriber who wishes to cancel his contract for telex service to cover the physical (i.e. labour) and administrative work involved.

5.2.7.4 Retainer fee

A retainer fee per month can be applied in lieu of the monthly equipment and connection fee to those customers who opt to retain or fail to request removal of the private wire installation and do not have telex equipment installed on their premises.

5.3 Private leased circuit service

5.3.1 Definition

5.3.1.1 The private leased circuit service consists of making one or more circuits available to a customer for his dedicated use.

5.3.1.2 The private leased channel is generally provided on a full period basis 24 hours per day, 7 days per week, 365 days per year.

5.3.2 General principles

5.3.2.1 The relevant provisions of Recommendations D.1 to D.5 and D.6 establish procedures for ordering the provision of facilities and the duration of the lease.

5.3.2.2 In determining their tariffs, Administrations should take into account the costs of providing the service. They are generally based on marketing considerations rather than on absolute cost basis.

5.3.3 Tariff structure

There may be separate tariff components or charges, e.g. fees for connection to the exchange, a per kilometre charge based on the distance from the exchange and a charge for DTE/DCE interface equipment, all of which may vary according to the transmission speed and other factors.

Tariff components must be assigned to different categories reflecting the underlying nature of the costs.

5.3.3.1 Non-recurring costs, e.g. the installation charge, should generally be recovered by a non-recurring charge.

5.3.3.2 Recurring costs, e.g. the subscription charge, should generally be recovered by a recurring charge.

5.3.4 Initial charges and subscriber rentals

Initial charges and subscriber rentals are independent of use and must at least cover such costs as financial charges for the equipment supplied by the Administration and maintenance of individual customer equipment and other operating costs.

5.3.5 Utilization charges

The following factors should be taken into consideration when establishing the tariffs:

- distance between terminal;
- circuit capacity (modulation speed and bandwidth);
- operating schedules; and
- transmission facilities.

CHAPTER 6 – USEFUL INFORMATION

6.1 Useful life

The weighted mean useful life is used, on the basis of investment costs, to calculate annual financial charges for equipment in service, by applying an assumed rate of return on capital invested.

TABLE 1

Designation	Useful life
Analogue	8-12 years
Digital	12-15 years
Transmission equipment	10-20 years
Ducts	20-65 years
Underground cables	20-32 years
Overhead cables	10-30 years
Buildings	30-60 years
Trunk exchanges	10-20 years
Local exchanges	10-25 years
PABXs	5-15 years ^{a)}
Teleprinters	7-10 years ^{a)}
Telephone sets	7-10 years ^{a)}
^{a)} Terminal apparatus is an area increasingly open to competition in many countries, as it permits Administrations to free up limited investment capital to improve and expand network infrastructure. Therefore, useful life for terminal apparatus may vary widely from one country to another.	

6.2 Time-value factor

The time-value factor permits a comparison between expenditure in different years. The following formula is generally used:

$$C_0 = \frac{CT}{(1+a)^T}$$

CT = cost in year T

C_0 = cost in year 0 of the updated costs

a = time-value factor

The time-value factor is fixed at the national level for public investment. It reflects a long-term balance between the financial requirements of economic development and financing capacities produced by overall savings.

It may differ from one country to another, depending on economic circumstances.

6.3 Maintenance and operating costs in relation to investment

See Table 2.

TABLE 2

Designation	Rates
Buildings	1 - 8%
Primary centres	3 - 6%
Local centres	3 - 6%
Overhead cables	5 - 11%
Concentrators	3 - 6%
Ducted cables	2 - 4%
Buried cables	3 - 6%
Amplification and power supply equipment	3 - 5%
Cable transmission equipment	2 - 4%
Radio-relay transmission equipment	2 - 6%

When actual expenditure is not known, the above rates can be used. They cover the cost of preventive and curative maintenance, the management and use of installed plant and repairs to damaged equipment.

6.4 Sample breakdown of initial investment between basic national telephone services⁴

See Table 3.

TABLE 3

Initial investment component	Total	Category of service – % breakdown of costs			
		Subscriber access	Local call	Trunk call	
				Area call	Inter-area call
Trunk transmission	100	-	-	30	70
Local network	100	100	-	-	-
Inter-exchange transmission	100	-	59	12	29
Land and buildings	100	100	-	-	-
Local switching – analogue model	100	48	35	5	12
Local switching – digital model	100	77	12	3	8
Tandem switching	100	-	-	30	70
Subscriber maintenance	100	100	-	-	-

6.5 Allowance for the consumption of telecommunication services

Allowing for the telecommunication services consumed by the operator consists of:

- i) identifying the consumption and expressing it in the same units as those used for outside customers;
- ii) dividing the costs assigned to the profit centres defined above into administration-related costs (Ca) and outside customer-related costs (Ce), for example pro rata to the different levels of consumption;
- iii) correcting the costs assigned to each profit centre by the following formula:

$$C(i) = CR(i) \cdot \left[1 + \frac{\sum Ca(j)}{\sum Ce(j)} \right]$$

where i is profit centre, i , and j is the full complement of profit centres studied.

The final cost obtained, $C(i)$, is then compared with the products covered.

⁴ This sample breakdown has been provided by Bezeq (Israel). Individual country breakdowns may vary according to a variety of factors, including geographical and demographic differences that may affect calling patterns.

CHAPTER 7 – CONCLUSIONS

7.1 The authors have endeavoured to offer the developing countries a theoretical model for determining tariffs, albeit one which each country will still have the arduous task of adjusting to its own specific situation. There are two essential conditions to be met before this can be done.

7.1.1 The first is to obtain reliable and sufficiently detailed information on the past and present situation of the undertaking. Data derived from a well-organized management cost accounting system are of the utmost importance, as of course is general information relating to the number of subscribers and to traffic.

7.1.2 The second is to acquire some insight into future developments. Ideally, tariffs are set for several years and it is therefore useful to have even a rough idea of how the situation will develop over that period, in order to make the arrangements for simulating the application of planned tariff measures.

7.2 The collection of information on the past and future situation of the undertaking is not usually part of the tariff expert's specific duties. If no adequate system exists for collecting such information, the first task must be to create or develop one. This is a prerequisite for the establishment of balanced tariffs which will place or maintain the undertaking on a sound economic footing.

ITU-T RECOMMENDATIONS SERIES

- Series A Organization of the work of the ITU-T
- Series B Means of expression
- Series C General telecommunication statistics
- Series D General tariff principles**
- Series E Telephone network and ISDN
- Series F Non-telephone telecommunication services
- Series G Transmission systems and media
- Series H Transmission of non-telephone signals
- Series I Integrated services digital network
- Series J Transmission of sound-programme and television signals
- Series K Protection against interference
- Series L Construction, installation and protection of cables and other elements of outside plant
- Series M Maintenance: international transmission systems, telephone circuits, telegraphy, facsimile and leased circuits
- Series N Maintenance: international sound-programme and television transmission circuits
- Series O Specifications of measuring equipment
- Series P Telephone transmission quality
- Series Q Switching and signalling
- Series R Telegraph transmission
- Series S Telegraph services terminal equipment
- Series T Terminal equipment and protocols for telematic services
- Series U Telegraph switching
- Series V Data communication over the telephone network
- Series X Data networks and open system communication
- Series Z Programming languages