



IEEE Standard Method for Measuring the Effectiveness of Electromagnetic Shielding Enclosures

IEEE Power Engineering Society

Sponsored by the
IEEE Electromagnetic Compatibility Committee

299TM

IEEE
3 Park Avenue
New York, NY 10016-5997, USA

28 February 2007

IEEE Std 299TM-2006
(Revision of IEEE Std 299-1997)

*Recognized as an
American National Standard (ANSI)*

IEEE Std 299™-2006

(Revision of
IEEE Std 299-1997)

IEEE Standard Method for Measuring the Effectiveness of Electromagnetic Shielding Enclosures

Sponsor

**Standards Development Committee
of the
IEEE Electromagnetic Compatibility Society**

Approved 29 December 2006

American National Standards Institute

Approved 15 September 2006

IEEE-SA Standards Board

Abstract: Uniform measurement procedures and techniques are provided for determining the effectiveness of electromagnetic shielding enclosures at frequencies from 9 kHz to 18 GHz (extendable to 50 Hz and 100 GHz, respectively) for enclosures having all dimension greater than or equal to 2.0 m. The types of enclosures covered include, but are not limited to, single-shield or double-shield structures of various construction, such as bolted demountable, welded, or integral with a building; and made of materials such as steel plate, copper or aluminum sheet, screening, hardware cloth, metal foil, or shielding fabrics.

Keywords: electromagnetic shielding, screened rooms, shielded enclosures, shielded rooms, shielding, shielding effectiveness

The Institute of Electrical and Electronics Engineers, Inc.
3 Park Avenue, New York, NY 10016-5997, USA

Copyright © 2007 by the Institute of Electrical and Electronics Engineers, Inc.
All rights reserved. Published 28 February 2007. Printed in the United States of America.

IEEE is a registered trademark in the U.S. Patent & Trademark Office, owned by the Institute of Electrical and Electronics Engineers, Incorporated.

Print: ISBN 0-7381-5215-3 SH95568
PDF: ISBN 0-7381-5216-1 SS95568

No part of this publication may be reproduced in any form, in an electronic retrieval system or otherwise, without the prior written permission of the publisher.

IEEE Standards documents are developed within the IEEE Societies and the Standards Coordinating Committees of the IEEE Standards Association (IEEE-SA) Standards Board. The IEEE develops its standards through a consensus development process, approved by the American National Standards Institute, which brings together volunteers representing varied viewpoints and interests to achieve the final product. Volunteers are not necessarily members of the Institute and serve without compensation. While the IEEE administers the process and establishes rules to promote fairness in the consensus development process, the IEEE does not independently evaluate, test, or verify the accuracy of any of the information contained in its standards.

Use of an IEEE Standard is wholly voluntary. The IEEE disclaims liability for any personal injury, property or other damage, of any nature whatsoever, whether special, indirect, consequential, or compensatory, directly or indirectly resulting from the publication, use of, or reliance upon this, or any other IEEE Standard document.

The IEEE does not warrant or represent the accuracy or content of the material contained herein, and expressly disclaims any express or implied warranty, including any implied warranty of merchantability or fitness for a specific purpose, or that the use of the material contained herein is free from patent infringement. IEEE Standards documents are supplied “**AS IS.**”

The existence of an IEEE Standard does not imply that there are no other ways to produce, test, measure, purchase, market, or provide other goods and services related to the scope of the IEEE Standard. Furthermore, the viewpoint expressed at the time a standard is approved and issued is subject to change brought about through developments in the state of the art and comments received from users of the standard. Every IEEE Standard is subjected to review at least every five years for revision or reaffirmation. When a document is more than five years old and has not been reaffirmed, it is reasonable to conclude that its contents, although still of some value, do not wholly reflect the present state of the art. Users are cautioned to check to determine that they have the latest edition of any IEEE Standard.

In publishing and making this document available, the IEEE is not suggesting or rendering professional or other services for, or on behalf of, any person or entity. Nor is the IEEE undertaking to perform any duty owed by any other person or entity to another. Any person utilizing this, and any other IEEE Standards document, should rely upon the advice of a competent professional in determining the exercise of reasonable care in any given circumstances.

Interpretations: Occasionally questions may arise regarding the meaning of portions of standards as they relate to specific applications. When the need for interpretations is brought to the attention of IEEE, the Institute will initiate action to prepare appropriate responses. Since IEEE Standards represent a consensus of concerned interests, it is important to ensure that any interpretation has also received the concurrence of a balance of interests. For this reason, IEEE and the members of its societies and Standards Coordinating Committees are not able to provide an instant response to interpretation requests except in those cases where the matter has previously received formal consideration. At lectures, symposia, seminars, or educational courses, an individual presenting information on IEEE standards shall make it clear that his or her views should be considered the personal views of that individual rather than the formal position, explanation, or interpretation of the IEEE.

Comments for revision of IEEE Standards are welcome from any interested party, regardless of membership affiliation with IEEE. Suggestions for changes in documents should be in the form of a proposed change of text, together with appropriate supporting comments. Comments on standards and requests for interpretations should be addressed to:

Secretary, IEEE-SA Standards Board
445 Hoes Lane
Piscataway, NJ 08854
USA

Authorization to photocopy portions of any individual standard for internal or personal use is granted by the Institute of Electrical and Electronics Engineers, Inc., provided that the appropriate fee is paid to Copyright Clearance Center. To arrange for payment of licensing fee, please contact Copyright Clearance Center, Customer Service, 222 Rosewood Drive, Danvers, MA 01923 USA; +1 978 750 8400. Permission to photocopy portions of any individual standard for educational classroom use can also be obtained through the Copyright Clearance Center.

Introduction

This introduction is not part of IEEE Std 299-2006, IEEE Standard Method for Measuring the Effectiveness of Electromagnetic Shielding Enclosures.

This document provides a standard set of methods and procedures for determining the shielding effectiveness (SE) of shielding enclosures. The enclosures of concern include those used for testing groups of equipment, vehicles, computing systems, and smaller units whose electromagnetic (EM) emission and susceptibility require determination without disturbance from other sources. This standard incorporates the basic concepts of MIL-STD-285,^a the SE measurement reference for many years, which was cancelled by the U.S. Department of Defense in 1997. Those concepts have been expanded upon to increase the applicability of the measurement techniques to enclosures having a wide variety of applications and constructed from a large number of materials with varying methods of fabrication and assembly.

The basic premise of MIL-STD-285 is still in position: the shield effect is to provide an insertion loss to outside influence. IEEE Std 299-2006 offers testing based upon the performance specifications of the shield, rather than a fixed set of parameters that may not be applicable to the shield in question. The specific test procedures and frequency ranges are selected as appropriate for the enclosure being tested. The most important factor considered during the development of this revision was the concept that measurement of EM SE is a requirement not unique to walk-in sized enclosures. There are no widely accepted standards in use to describe test methods and techniques for measuring SE of physically small enclosures. The Standards Development Committee of the IEEE Electromagnetic Compatibility Society directed the current Working Group to plan for developing new parts of IEEE Std 299 for addressing the testing of these smaller enclosures. Thus, this document will continue to provide a standardized test method for EM shielded enclosures having all dimensions greater than or equal to 2 m. New parts of IEEE Std 299 will be developed soon to address these smaller enclosures.

Notice to users

Errata

Errata, if any, for this and all other standards can be accessed at the following URL: <http://standards.ieee.org/reading/ieee/updates/errata/index.html>. Users are encouraged to check this URL for errata periodically.

Interpretations

Current interpretations can be accessed at the following URL: <http://standards.ieee.org/reading/ieee/interp/index.html>.

^a MIL publications are available from Customer Service, Defense Printing Service, 700 Robbins Ave., Bldg. 4D, Philadelphia, PA 19111-5094, USA.

Patents

Attention is called to the possibility that implementation of this standard may require use of subject matter covered by patent rights. By publication of this standard, no position is taken with respect to the existence or validity of any patent rights in connection therewith. The IEEE shall not be responsible for identifying patents or patent applications for which a license may be required to implement an IEEE standard or for conducting inquiries into the legal validity or scope of those patents that are brought to its attention.

Participants

The many contributions to this standard by the members of the P299 Working Group are gratefully acknowledged. The support of the Vice Chairs, Norman Wehling (retired) and Dr. Croisant, was invaluable, as were the editing efforts of Mark Bushnell and improvements to the figures by Joseph Weibler. Professor Sarto was also extremely helpful in clarifying many of the concepts and equations.

Special appreciation is extended to Don Sweeney who served as liaison from the EMC Society Standards Development Committee and “Angel” for the project.

At the time this standard was completed, the P299 Working Group had the following membership:

Dale G. Svetanoff, *Chair*

(July 1995 to present)

William Croisant, *Vice Chair*

(January 2001 to present)

Norman Wehling, *Vice Chair*

(July 1995 to December 2000)

Gianluca Arcari
Robert Bonsen
Ed Bronaugh
Mark Bushnell
Joe Butler
Nigel Carter
Johan Catrysse
Paul Cook
Frederick Eriksen
Ahmad Fallah

Robert Harriman
Michael Hatfield
L. O. “Bud” Hoeft
Christopher Holloway
D. Mark Johnson
Mark Katrancha
James Klouda
Galen Koepke
David Larrabee
Andy Marvin
Michael McNerney

Ade Ogunsola
Jacques Rajade
Dale Reynolds
Peter Richeson
Maria Sabrina Sarto
Walter Scott
Doug Smith
James Whalen
Joseph Weibler
John Wyncott

The following members of the individual balloting committee voted on this standard. Balloters may have voted for approval, disapproval, or abstention.

David Baron
Stephen Berger
Mark Bushnell
Jim Carlo
Johan Catrysse
Keith Chow
Guru Dutt Dhingra

Tim Harrington
Werner Hoelzl
Daniel Hoolihan
Efthymios Karabetos
Yuri Khersonsky
Ronald Kollman
John Kraemer

Yeou-Song Lee
Li Li
Edward McCall
Kermit Phipps
Werner Schaefer
Dale G. Svetanoff
Donald Sweeney

When the IEEE-SA Standards Board approved this standard on 15 September 2006, it had the following membership:

Steve M. Mills, *Chair*
Richard H. Hulett, *Vice Chair*
Don Wright, *Past Chair*
Judith Gorman, *Secretary*

Mark D. Bowman
Dennis B. Brophy
William R. Goldbach
Arnold M. Greenspan
Robert M. Grow
Joanna N. Guenin
Julian Forster*
Mark S. Halpin

Kenneth S. Hanus
William B. Hopf
Joseph L. Koepfinger*
David J. Law
Daleep C. Mohla
T. W. Olsen
Glenn Parsons
Ronald C. Petersen
Tom A. Prevost

Greg Ratta
Robby Robson
Anne-Marie Sahazizian
Virginia Sulzberger
Malcolm V. Thaden
Richard L. Townsend
Walter Weigel
Howard L. Wolfman

*Member Emeritus

Also included are the following nonvoting IEEE-SA Standards Board liaisons:

Satish K. Aggarwal, *NRC Representative*
Richard DeBlasio, *DOE Representative*
Alan H. Cookson, *NIST Representative*

Don Messina
IEEE Standards Program Manager, Document Development

William Ash
IEEE Standards Program Manager, Technical Program Development

Contents

1. Overview	1
1.1 Scope	1
1.2 Purpose	1
1.3 Application	1
2. Normative references.....	2
3. Definitions.....	2
3.1 General terminology.....	2
3.2 Technical terminology.....	3
4. Preliminary procedures.....	3
4.1 Background.....	3
4.2 Test plan	4
4.3 Calibration	4
4.4 Reference level and dynamic range	4
4.5 Preliminary shield check procedures	4
4.6 Test/witness personnel.....	4
5. Detailed procedures.....	4
5.1 Background.....	4
5.2 Recommended standard measurement frequencies	5
5.3 Pass/fail requirements.....	6
5.4 Shielding effectiveness calculation.....	6
5.5 Preparation procedures	7
5.6 Low-frequency measurements (9 kHz to 20 MHz)	7
5.7 Resonant range measurements (20 MHz to 300 MHz).....	11
5.8 High-frequency measurements (300 MHz to 18 GHz).....	18
6. Quality assurance technical report.....	24
6.1 Abbreviated test report	24
6.2 Full test report.....	24
Annex A (informative) Rationale	26
A.1 Basis.....	26
A.2 Considerations pertinent to the objectives of 1.2.....	26
A.3 Cavity resonances	27
A.4 Measurement locations	30
A.5 Measurement equipment.....	30

Annex B (informative) Mathematical formulas.....	31
B.1 Specific mathematical formulations.....	31
B.2 Low-range (50 Hz to 20 MHz) shielding effectiveness	31
B.3 Resonant range (20 MHz to 300 MHz) shielding effectiveness.....	32
B.4 High-range (300 MHz to 100 GHz) shielding effectiveness.....	32
B.5 Nonlinear (logarithmic) calculations.....	32
B.6 Dynamic range considerations	33
Annex C (informative) Miscellaneous supporting information.....	34
C.1 Coplanar versus coaxial loops.....	34
C.2 Nonlinearity of high-permeability ferromagnetic enclosures.....	34
C.3 Selecting measurement frequencies	34
Annex D (informative) Guidelines for the selection of measurement techniques.....	37
D.1 Types of enclosures	37
D.2 Performance requirements	37
D.3 Equipment requirements.....	38
D.4 Regulatory agency conflicts.....	38
Annex E (informative) Preliminary measurements and repairs.....	39
E.1 Background	39
E.2 Frequencies for preliminary check	39
E.3 Preliminary check procedures	39

IEEE Standard Method for Measuring the Effectiveness of Electromagnetic Shielding Enclosures

1. Overview

1.1 Scope

This standard provides uniform measurement procedures for determining the effectiveness of electromagnetic (EM) shielding enclosures at frequencies from 9 kHz to 18 GHz (extendable down to 50 Hz and up to 100 GHz).

The owner of the shielding enclosure shall provide the frequencies at which the shield will be tested, and the shielding effectiveness (SE) limits for pass/fail. This standard suggests a range of test frequencies that would provide very high confidence in the effectiveness of the shield. This standard does not define SE limits for pass or fail.

1.2 Purpose

The purpose of this standard is to provide the following:

- a) A standard procedure for the measurement of the effectiveness of shielded enclosures, in a broad range of radio frequencies (RFs), including a minimum set of recommended frequencies
- b) Identical procedures applicable to frequencies other than the standard set
- c) An optional measurement technique to detect the nonlinear behavior of high-permeability ferromagnetic enclosures (see Annex C)

1.3 Application

The measurement procedures provided in this standard apply to any enclosure having a smallest linear dimension greater than or equal to 2.0 m. Separate methods, to be provided in the future, shall be used for enclosures with any dimension smaller than 2.0 m.

In the case of enclosures that are to be used in anechoic or semianechoic applications, this procedure shall apply prior to the installation of any RF absorber materials.

2. Normative references

The following referenced documents are indispensable for the application of this document. For dated references, only the edition cited applies. For undated references, the latest edition of the referenced document (including any amendments or corrigenda) applies.

ANSI C63.2, American Standard for Electromagnetic Noise and Field Strength Instrumentation, 10 kHz to 40 GHz—Specifications.¹

ANSI/NCSL Z540, U.S. Guide to the Expression of Uncertainty in Measurement.

IEEE 100™, *The Authoritative Dictionary of IEEE Standards Terms*, Seventh Edition.^{2,3}

IEEE Std 291™, IEEE Standard Method for Measuring Electromagnetic Field Strength of Sinusoidal Continuous Waves, 30 Hz to 30 GHz.

IEEE Std 473™, IEEE Recommended Practice for an Electromagnetic Site Survey (10 kHz to 10 GHz).⁴

IEEE Std C95.1™, IEEE Standard for Safety Levels with Respect to Human Exposure to Radio Frequency Electromagnetic Fields, 3 kHz to 300 GHz.

ISO/IEC 17025, General Requirements for the Competence of Testing and Calibration Laboratories.⁵

NIST TN 1297, Guidelines for Evaluating and Expressing the Uncertainty of NIST Measurement Results, Barry N. Taylor and Chris E. Kuyatt.⁶

UKAS LAB 34, The Expression of Uncertainty in EMC Testing.⁷

3. Definitions

For the purposes of this standard, the following terms and definitions apply. *The Authoritative Dictionary of IEEE Standards Terms* should be referenced for terms not defined in this clause.

3.1 General terminology

3.1.1 shall: Indicates mandatory requirements strictly to be followed in order to conform to the standard and from which no deviation is permitted (*shall equals is required to*).

¹ ANSI publications are available from the Sales Department, American National Standards Institute, 25 West 43rd Street, 4th Floor, New York, NY 10036, USA (<http://www.ansi.org/>).

² IEEE publications are available from the Institute of Electrical and Electronics Engineers, 445 Hoes Lane, Piscataway, NJ 08855-1331, USA (<http://standards.ieee.org/>).

³ The IEEE standards or products referred to in this clause are trademarks of the Institute of Electrical and Electronics Engineers, Inc.

⁴ IEEE Std 473 has been withdrawn; however, copies can be obtained from Global Engineering, 15 Inverness Way East, Englewood, CO 80112-5704, USA, tel. (303) 792-2181 (<http://global.ihs.com/>).

⁵ ISO/IEC publications are available from the ISO Central Secretariat, Case Postale 56, 1 rue de Varembe, CH-1211, Genève 20, Switzerland/Suisse (<http://www.iso.ch/>). ISO/IEC publications are also available in the United States from Global Engineering Documents, 15 Inverness Way East, Englewood, CO 80112, USA (<http://global.ihs.com/>). Electronic copies are available in the United States from the American National Standards Institute, 25 West 43rd Street, 4th Floor, New York, NY 10036, USA (<http://www.ansi.org/>).

⁶ NIST publications are available from the Superintendent of Documents, U.S. Government Printing Office, Washington, DC 20402-9325 USA (<http://www.nist.gov/>).

⁷ UKAS publication are available from the United Kingdom Accreditation Service, 8500 21-47 High Street, Feltham Middlesex TW13 4UN (<http://www.ukas.com/>).

3.1.2 should: Indicates that among several possibilities one is recommended as particularly suitable, without mentioning or excluding others; or that a certain course of action is preferred but not necessarily required; or that (in the negative form) a certain course of action is deprecated but not prohibited (*should equals is recommended that*).

3.2 Technical terminology

3.2.1 accessible test location: A location that can be reached by a test antenna or probe without modifying a parent structure.

3.2.2 dynamic range (DR): The range of amplitudes over which the receive system operates linearly (see B.6). For a measurement, the DR is the difference between the reference level and the minimum discernable signal above the noise floor. The minimum discernable signal is defined as one with an amplitude of 3 dB or more above the test system noise floor. This is what should be verified during the DR validation step of the SE procedures defined in 4.4 of this standard, and represents the maximum SE measurable at that frequency with that particular equipment and settings.

3.2.3 local source: An emitter located close enough to a shielding enclosure for its EM energy to illuminate only a localized portion of a shielding face. The effect is assessed by choosing the poorest performance in the set of measured locations.

3.2.4 owner (shielded enclosure user or owner): The individual, corporation, or organization that intends to use the shield and that is the ultimate source of the shielding requirement.

3.2.5 parent structure: A permanent enclosure or outside housing that contains the shielding enclosure.

3.2.6 shielding effectiveness (SE): The ratio of the signal received (from a transmitter) without the shield, to the signal received inside the shield; the insertion loss when the shield is placed between the transmitting antenna and the receiving antenna (IEEE 100-2000).

3.2.7 shielding enclosure: A structure that protects its interior from the effect of an exterior electric or magnetic field, or conversely, protects the surrounding environment from the effect of an interior electric or magnetic field. A high-performance shielding enclosure is generally capable of reducing the effects of both electric and magnetic field strengths by one to seven orders of magnitude depending upon frequency. An enclosure is normally constructed of metal with provisions for continuous electrical contact between adjoining panels, including doors.

3.2.8 testing organization: The organization that actually performs the tests and records the data.

4. Preliminary procedures

4.1 Background

The detailed procedures required for the measurement of SE are defined in Clause 5. There are a number of steps (reference measurement, measurement of DR) that must be taken before the SE is measured, however, and these steps are defined in 4.2 through 4.6.

Initial performance checks of the shield, prior to measurement data collection, are not required by this standard. Refer to Annex E for suggested procedures, if desired.

4.2 Test plan

A test plan shall be prepared. The plan shall be approved by the owner or owner's representative prior to the start of test. Tests shall be performed in accordance with the approved test plan.

The test plan shall include, but shall not be limited to, actual test frequencies, test result pass/fail requirements, test locations, and a proposed equipment list. In addition, requirements for maintenance of a test log and an accepted procedure for making changes to the test plan that may arise during testing should be included.

4.3 Calibration

Any piece of equipment, whose operation directly affects the numerical value of the SE, shall be in calibration before any critical measurements are begun. Dates of latest calibration (traceable to a national standard) shall be provided and shall be within the calibration cycle of the equipment.

4.4 Reference level and dynamic range

A reference level shall be determined as described in 5.6.4, 5.7.4, and 5.8.4, which address the low-frequency (magnetic), resonant range, and high-frequency (plane wave) measurements. This determination may be made as frequently as required by changes in the test configuration. The reference level shall be remeasured at the conclusion of testing at each frequency. The tests since the prior reference level determination shall be repeated if the values have varied by more than ± 3 dB.

Each unique equipment configuration used to measure SE shall be demonstrated to have adequate DR. Determination of the DR shall consist of excitation of the receiving equipment with the associated transmitting equipment, and demonstration that the equipment remains calibrated (linear) for all levels of received and transmitted signals that are actually experienced during the test. This demonstration shall be accomplished by varying the receiver input with a calibrated attenuator external to the receiver and observing an equal change, in decibels, in the receive system. Alternatively, the input attenuator of the instrument can be used. In this case, linear operation is present if no change in signal amplitude is observed when changing the input attenuator setting. This test shall be done at least once for each test frequency.

The DR shall be at least 6 dB greater than the SE to be measured. DR can most efficiently be determined during the reference measurement. Effects of surrounding structure (walls, buildings, etc.) shall be minimized.

4.5 Preliminary shield check procedures

See Annex E for preliminary measurements and repairs.

4.6 Test/witness personnel

It is not desirable to have personnel within the shielded enclosure during testing. If required, a maximum of two (2) people is allowed within the shielded enclosure. This is intended to allow a tester and a witness.

5. Detailed procedures

5.1 Background

This clause contains the detailed procedures for the SE measurements. This standard defines a test procedure but does not define the frequencies at which the measurements should be made, nor does it

define the minimum SE that constitutes pass/fail. The owner shall define these frequencies and all pass/fail requirements.

However, as a guide for owners, this standard recommends frequencies that can be selected for testing their shield. Successful tests at these frequencies should provide very high confidence that a shield system provides the specified SE at all the frequencies from 9 kHz to 18 GHz.

The detailed procedures are divided into three ranges, denoted as low frequency, resonance, and high frequency. Separate and distinct procedures and equipment are required in each of these ranges.

WARNING

For all measurements undertaken as a part of this standard, care shall be taken to protect personnel from potentially hazardous RF field levels (IEEE Std C95.1-1999).⁸ This standard also suggests that authorization for transmit operation be obtained from the appropriate regulatory agency prior to activation of any transmitter. See C.3 of this standard for selecting measurement frequencies.

Care shall also be taken to avoid interference with other electronic equipment operating in the vicinity.

5.2 Recommended standard measurement frequencies

Test frequencies shall be chosen by the owner. Recommended test frequencies are defined in Table 1.

Table 1—Standard measurement frequencies

Standard frequency	Antenna type	Clause procedure
Low range^a		
9 kHz–16 kHz	Small loop	5.6
140 kHz–160 kHz	↓	↓
14 MHz–16 MHz	↓	↓
Resonant range^a		
20 MHz–100 MHz	Biconical	5.7
100 MHz–300 MHz	Dipole	↓
High range^b		
0.3 GHz–0.6 GHz	Dipole	5.8
0.6 GHz–1.0 GHz	↓	↓
1.0 GHz–2.0 GHz	Horn	↓
2.0 GHz–4.0 GHz	↓	↓
4.0 GHz–8.0 GHz	↓	↓
8.0 GHz–18 GHz	↓	↓

^a Actual test frequencies shall be according to the approved test plan.

^b A single frequency in each band is recommended, but actual test frequencies shall be according to the approved test plan.

The frequencies may be extended to lower and higher ranges. Table 2 contains recommended frequencies in the extended ranges.

⁸ For information on references, see Clause 2.

Table 2—Recommended extended range measurement frequencies

Frequency range	Antenna type	Clause procedure
50 Hz–110 Hz	Small loop	5.6
0.9 kHz–1.1 kHz	↓	↓
35 GHz–45 GHz	Horn	5.8
90 GHz–100 GHz	↓	↓

5.3 Pass/fail requirements

Minimum acceptable pass/fail requirements shall be defined by the owner.

5.4 Shielding effectiveness calculation

5.4.1 General

Data obtained by the measurement procedures of 5.6.5, 5.7.5, and 5.8.5 are converted to SE by mathematical relationships defined in Table 3 and Annex B. The magnitudes of the quantities E_1 , E_2 , H_1 , and H_2 are the field values measured using the antennas placed in the prescribed configuration.

Table 3—Mathematical shielding relationships

Frequency range	Measured quantities	Units	Shielding effectiveness (dB)
Linear units			
9 kHz–20 MHz (extendable down to 50 Hz)	$ H_1 , H_2 $	$\mu\text{A/m}, \mu\text{T}$	$SE_H = 20 \log_{10} \frac{ H_1 }{ H_2 }$ (B.1) ^a
	$ V_1 , V_2 $	μV	$SE_H = 20 \log_{10} \frac{ V_1 }{ V_2 }$ (B.2)
20–300 MHz	$ E_1 , E_2 $	$\mu\text{V/m}$	$SE_E = 20 \log_{10} \frac{ E_1 }{ E_2 }$ (B.3)
300 MHz–1.7 GHz and 1.7 GHz–18 GHz (extendable up to 100 GHz)	P_1, P_2	watts	$SE_P = 10 \log_{10} \frac{P_1}{P_2}$ (B.4)
Logarithmic units			
All frequencies (as listed above)	All, in dB related values	dB	$SE = E_1 \text{ (dB)} - E_2 \text{ (dB)}$ (B.5a)
			$SE = H_1 \text{ (dB)} - H_2 \text{ (dB)}$ (B.5b)
			$SE = V_1 \text{ (dB)} - V_2 \text{ (dB)}$ (B.5c)
			$SE = P_1 \text{ (dB)} - P_2 \text{ (dB)}$ (B.5d)

^a See Annex B for Equation (B.1) through Equation (B.5d).

5.4.2 Measurement uncertainty

Measurement uncertainty is a parameter that can be associated with the result of a measurement of SE. It characterizes the dispersion of values that could reasonably be attributed to the measurements. There are many aspects of SE where measurement uncertainty can be estimated to gain the overall expanded measurement uncertainty of the SE process contained in this standard. These include the uncertainties caused by the measurement instrumentation chain itself, the positioning of the transmit and receive antennas, the RF loading of the room, and its effect on the room Q value, caused by the test personnel in the room, etc. Work is in progress to address these uncertainty components. However, for the present and until this work is concluded, uncertainty is not required in the measurement of SE. It is recommended that a measurement uncertainty analysis be performed on each set of measurements and discussed in the final report. Clause 2 lists several references that can be used.

5.5 Preparation procedures

Before detailed measurements are undertaken, the equipment shall be calibrated in accordance with 4.3, and reference levels and DR shall be determined in accordance with 4.4.

5.6 Low-frequency measurements (9 kHz to 20 MHz)

Standard low-frequency measurements utilize a small electrostatically shielded loop that, because of its size, enables evaluation of the performance of the enclosure when exposed to magnetic sources near the enclosure walls.

5.6.1 Frequency range and band

The small-loop method provides a standard test procedure for the 9 kHz to 20 MHz range. The three recommended frequencies for shielding measurements are a single frequency within the 9 kHz to 16 kHz band, one within the 140 kHz to 160 kHz band, and another within the 14 MHz to 16 MHz band. Actual test frequencies shall be selected by the owner.

These procedures are extendable down to 50 Hz. At lower frequencies, it is anticipated that somewhat different equipment may be required to gain adequate DR. For example, additional turns may be required on the receive and/or transmit loop antennas.

5.6.2 Equipment and setup

Signal sources, measuring equipment, and arrangement shall be in accordance with 5.6.2.1, 5.6.2.2, and Figure 1. All equipment shall have written proof of current calibration in accordance with 4.3.

CAUTION

Resonance conditions can occur if the transmit antenna is placed inside the shielded room. This possibility is strongly dependent on the Q of the chamber. In some cases, just a few centimeters of change in the test position can give significantly different readings of SE. In some jurisdictions, special temporary authorization is required to perform this test with the transmit antenna outside the test chamber. Contact the appropriate regulatory authority for instructions on securing such temporary authorization.

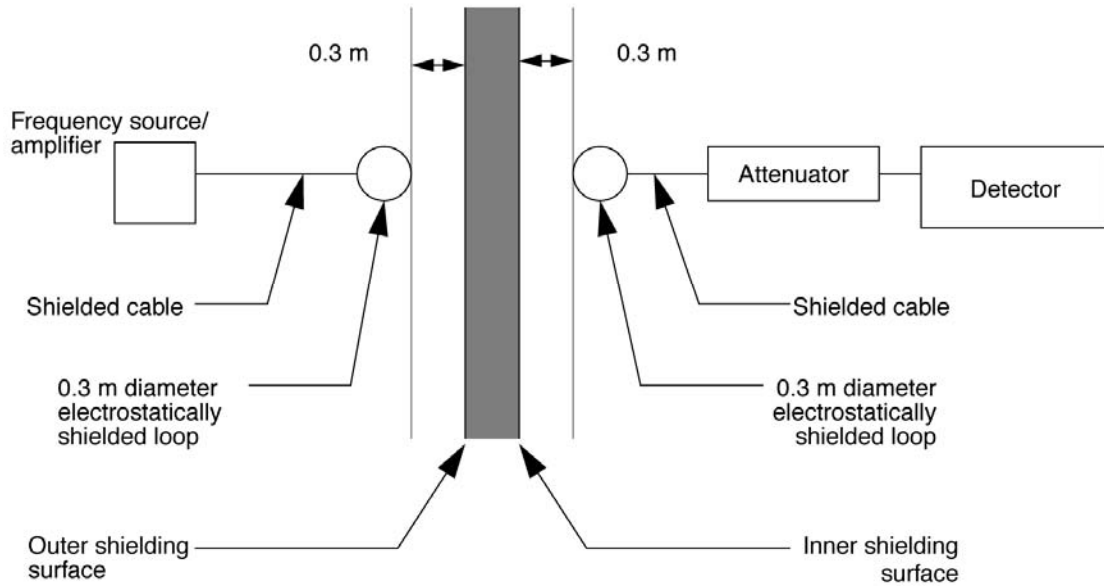

Figure 1—Schematic diagram of the test configuration for magnetic tests showing dimensions of transmit and receive antennas (coplanar antenna orientations)

5.6.2.1 Source of magnetic field

The magnetic field shall be generated by a current in a 0.3 m diameter electrostatically shielded loop antenna. An ordinary audio frequency generator, plus amplifier, is usually adequate to supply the loop current if a suitable impedance matching device is used. Impedance matching may be needed to obtain the required DR. A continuous wave (CW) signal without modulation shall be used to drive the antenna.

5.6.2.2 Receive antenna

The receive antenna shall be a 0.3 m diameter electrostatically shielded loop connected to a field-strength meter, spectrum analyzer, or similar device.

5.6.3 Preliminary procedure

The nonlinear behavior of high-permeability ferromagnetic enclosures shall be considered before measuring shielding performance (see Annex C). Magnetic field testing specifically in the 14 MHz to 16 MHz range is strongly recommended because of good sensitivity to shielding defects in that range. Problem areas shall be identified.

5.6.4 Reference measurements

The reference field (H_1) produced by the source in the absence of the shielding enclosure shall be obtained by direct measurement with the receiving loop spaced from the transmitting loop by 0.6 m edge to edge (see C.1) plus the thickness of the shielding barrier, which is the same total loop-to-loop distance that will be utilized when a shielding barrier intervenes. Both loop antennas shall be in the same plane (coplanar).

At this time, the adequacy of the DR shall be demonstrated in accordance with the procedures in 4.4.

5.6.5 Measurement procedure

5.6.5.1 General

The measurements shall be made in accordance with Figure 1 and Figure 2, with the transmitting and receiving loops each spaced by 0.3 m from the respective shielding barrier and coplanar in a plane perpendicular to the wall, ceiling, or other surface being measured. When testing the intersection of two surfaces, the antenna shall be orthogonal to both surfaces, as illustrated in Figure 2e) and Figure 2f). At each frequency and location, the generator output shall be maintained at the value used during the reference measurement (see 5.6.4).

During all low-frequency measurements, one loop (typically the transmit loop) shall be maintained in a fixed position and the second loop (typically the receive loop) shall be reoriented and displaced (physically swept at least one-fourth the seam length on either side of the exact coplanar location) to seek a worst-case measurement; the maximum indication of the detector reading shall be used for determining the SE. Therefore, it is acceptable to position the external and internal loops only approximately coplanar when beginning the search for the worst-case measurement; however, the final measurement shall be made in the coplanar configuration.

5.6.5.2 Measurement locations

Around single-panel entry doors, small-loop tests shall be conducted for 14 loop positions, as indicated in Figure 2a) and Figure 2b). The plane of the loop shall be perpendicular to the line of the door contact being tested. For the horizontal portion of the door seal, the loop shall be at the corners and equidistant from the edges. For the vertical contact regions, the loop centers shall be located at the corners and one-third the distance from both the top and the bottom. The top and bottom vertical contacts shall be measured as indicated in Figure 2b).

For multiple panel personnel or equipment entry doors, the previous test positions apply to each door. See Figure 2b) and Figure 2c).

For doors with dimensions exceeding 1.5 m × 2.5 m, additional test positions shall be added so that the spacing between test points does not exceed 1 m.

In the region of panel-to-panel seams, shielding enclosure construction is electrically nonuniform. Nonuniformities include regions where modular portions are joined together by a clamp or bolt assembly (or by staples for a foil-type shield), or by a soldered, brazed, or welded joint. Measurements shall be conducted in a similar manner to those around doors, except that the centers of the loops shall be located only at the midpoints of each seam or joint, whether horizontal or vertical, as in Figure 2d). In cases where the panel seams, whether bolted or welded, cannot be seen, attempts shall be made to determine the seam locations or panel sizes using applicable construction drawings or other documents. The test positions of Figure 2 shall be used for as much of the shield area as can be accessed for testing if the intervening nonshield materials are close enough to the shield to maintain the specified coupling distance between the loop antennas and shield proper.

The performance of an accessible corner seam shall be measured as shown in Figure 2f). Where the corner is not fully accessible, the arrangement shown in Figure 2e) may be used. Each accessible panel shall be tested.

Shielding performance at an air vent, access panel, or connector panel is measured similarly to a seam. For an air vent, the plane of the loop shall be perpendicular to the following: 1) the panel containing the air vent and 2) each seam formed between that panel and the air vent; the extended plane of the loop should pass through the midpoint of the seam or as close to the seam as possible. The edge of the loop shall be located 0.3 m from the panel. Ancillary equipment (such as blowers and fans) normally present during operation of the enclosure shall remain in place during the test. Other equipment that is not a normal part of the enclosure shall be removed prior to test.

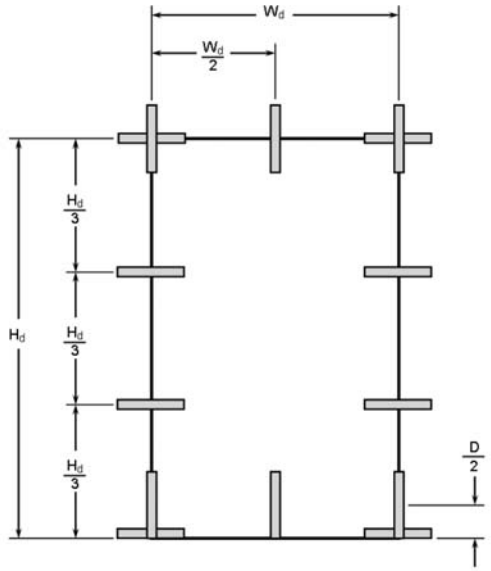

a) Single-panel entry door measurements

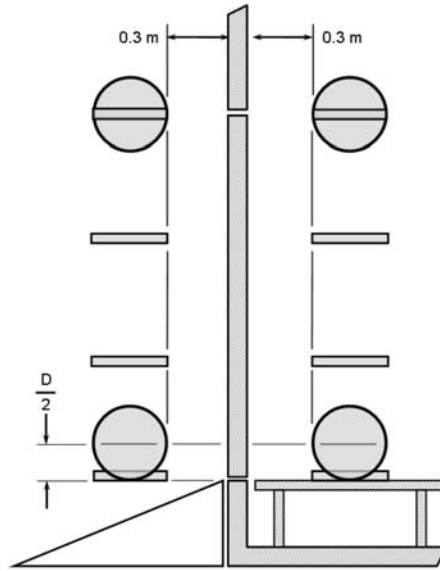

b) Door measurements

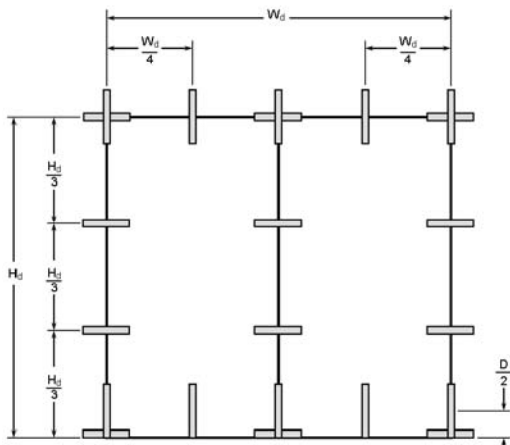

c) Double-panel entry door measurements

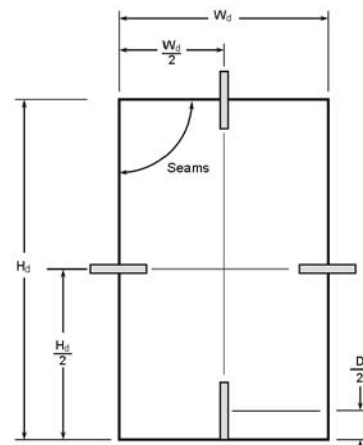

d) Panel seam measurements

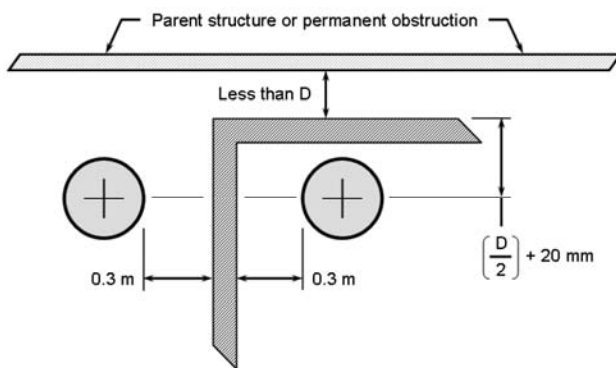

e) Partially accessible corner seam measurements

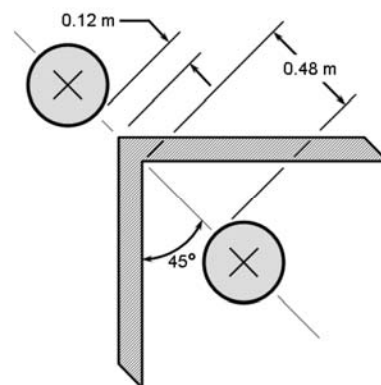

f) Fully accessible corner seam measurements

D = Outer diameter of loop antenna

Figure 2—Standard loop positions for low-frequency tests

For a single or small number of coaxial feed-through connectors, a single test position shall be satisfactory.

The shielding performance at power-line, signal-line, and control-line filters shall be measured. Each filter cabinet or filter box shall be tested at the penetration through the enclosure, and at nonsoldered or nonlead seams in the applicable case.

5.6.6 Determination of low-range shielding effectiveness

The SE shall be computed using Equation (B.1) or Equation (B.2) of Table 3, when linear units are used for measurement, or Equation (B.5b) or Equation (B.5c) of Table 3 when all meter readings are logarithmic in decibels.

5.7 Resonant range measurements (20 MHz to 300 MHz)

The resonant range procedure directly measures the effect of EM sources at positions over all accessible surfaces of the enclosure. It is recognized that impinging fields may not be planar, especially in the lower portions of the range. It is further recognized that the general geometric shape and physical size of the shielded enclosure can significantly affect measurements (see A.3.1).

5.7.1 Frequency range and band

This subclause provides a standard test procedure for the 20 MHz to 300 MHz range. Since the majority of enclosures that are expected to be tested with this procedure will have their fundamental resonance point in this range, it is recognized that testing of enclosures is frequently avoided at these frequencies. However, there are enclosure systems that are specified by their owners to provide a level of performance in this range due to the anticipated usage, or other factors, and that must be tested in this range regardless of potential resonance effects.

The testing shall be performed at a frequency or frequencies determined by the owner and incorporated in the approved test plan (see 4.2). All reasonable attempts should be made to avoid testing at, or very near, the enclosure resonant frequency as determined in 5.7.5.3.

If the performance of the enclosure is to be measured at a single frequency, f , in the resonant range of this standard, then tests shall be performed as follows:

- a) For an empty enclosure, tests shall be performed at $0.9f$, f , and $1.1f$. If these results do not agree within 3 dB, then it is recommended that additional tests be performed from $0.9f$ to $1.1f$ to determine the minimum SE.
- b) For an enclosure loaded with equipment that will become a permanent part of the enclosure, tests shall be performed at $0.8f$, $0.9f$, f , $1.1f$, and $1.2f$. If these results do not agree within 3 dB, then it is recommended that additional tests be performed from $0.8f$ to $1.2f$ to determine the minimum SE.

5.7.2 Test equipment and setup

Signal sources, measuring equipment, and arrangement shall be in accordance with 5.7.2.1, 5.7.2.2, 5.7.2.3, Figure 3, and Figure 4. The spacing between an antenna and the enclosure shall be the shortest distance between the enclosure and the closest points of the antenna elements. The separation distance between antennas shall be the distance between the closest points of each antenna's element.

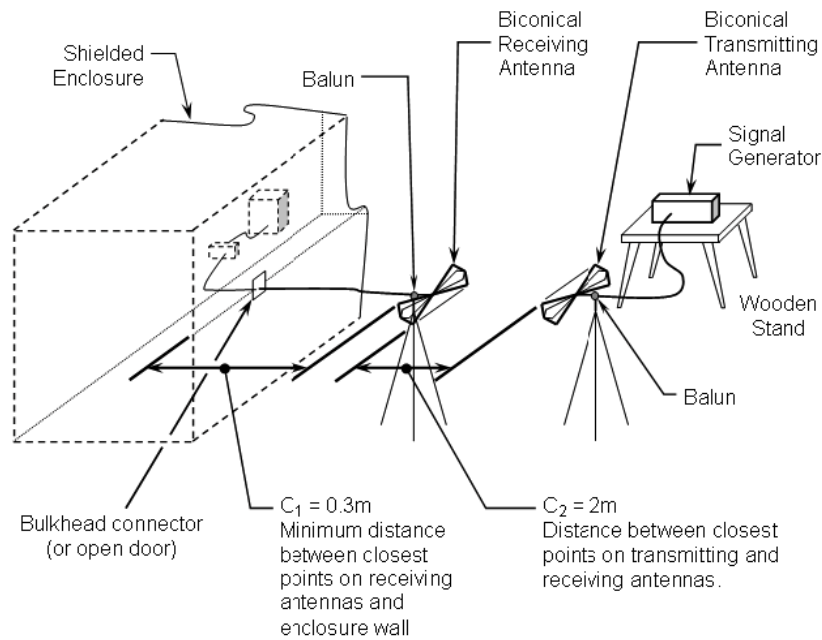

a) Reference measurement setup (horizontal antenna orientation), 20 MHz–100 MHz

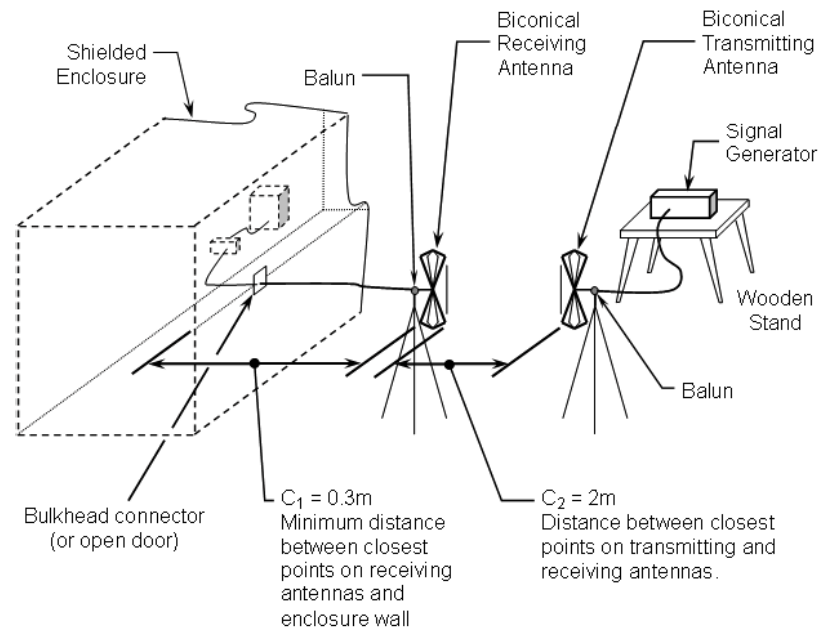

b) Reference measurement setup (vertical antenna orientation), 20 MHz–100 MHz

Figure 3—Schematic diagram of reference level configuration for resonant range tests

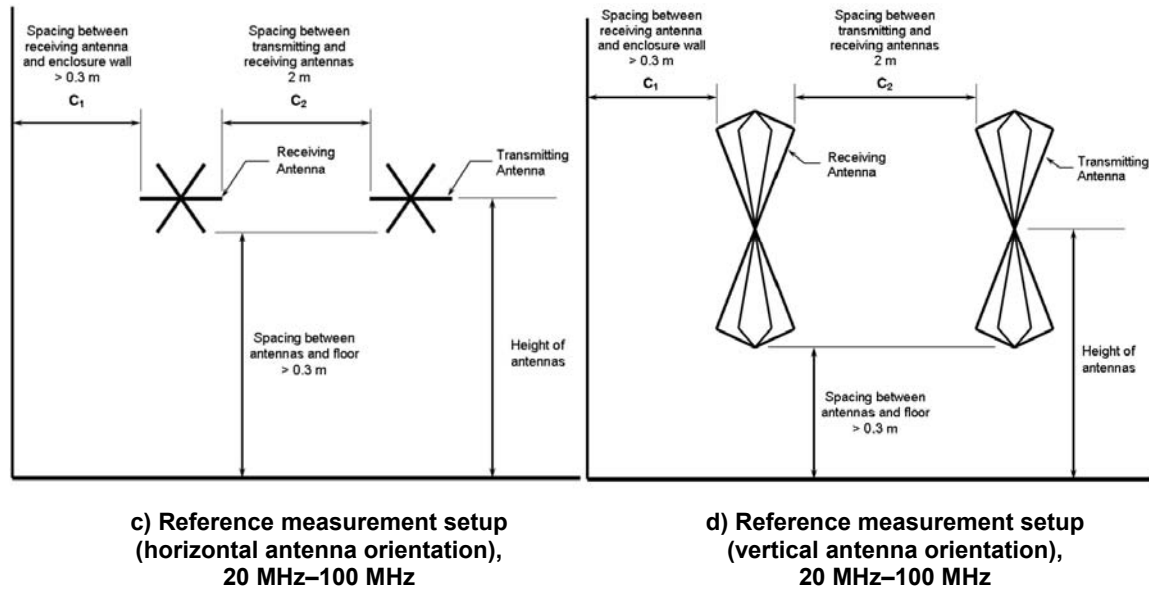

Figure 3—Schematic diagram of reference level configuration for resonant range tests
(continued)

5.7.2.1 Sources of electromagnetic fields

The EM fields shall be generated by power applied to a biconical antenna for frequencies in the range of 20 MHz to 100 MHz, and by power applied to a $\lambda/2$ dipole for frequencies at or above 100 MHz. Power into the antenna shall be adequate to maintain the required measurement DR. A CW signal without modulation shall be used to drive the antenna.

5.7.2.2 Receive antenna

The receive antenna shall be of the same type used for transmitting. Where a dipole is used, it shall also be sized $\lambda/2$, and its output shall be through a balun transformer via coaxial cable to the field-strength measuring device. For either antenna type, the cable shall be perpendicular to the axis of the antenna for a distance of at least 1 m. The cable shall employ either continuous loaded ferrite jacketing or ferrite beads located at the ends and midpoint of the cable. False resonances may be seen as a result of the interconnecting cables, and therefore, the length and type of cable used shall be noted in the measurement results.

5.7.2.3 Detector of fields

The field strength measuring device shall be a receiver, spectrum analyzer, or equivalent.

5.7.3 Preliminary procedures

Before formal testing is begun, the testing organization is encouraged to test for leaks in the shield (and repair them) in accordance with the recommended procedures of Annex E. However, this preliminary check is not a mandatory part of the standard.

5.7.4 Reference measurements

The reference level is the value of signal measured by the detector instrument with the receiving antenna located at a prescribed distance from the transmit antenna and located outside of the shielding enclosure.

Measurement of the reference level shall be in accordance with Figure 3. The method used is the same for either antenna type. The reference level is measured by the following method, which is designed to be conducted within typical facilities housing shielded enclosures and with a minimum reliance on long-term calibrations.

The antennas shall be separated by a distance of 2 m, minimum, unless physical spacing limitations for either the reference level or SE readings preclude maintaining that spacing. In that event, maximum available separation shall be used, but shall not be less than 1 m, and that separation shall be noted on the test report and data sheets.

The coaxial cable from the receive antenna shall be kept perpendicular to the axis of the antenna for a distance of at least 1 m, except when in the immediate vicinity of the shielding enclosure. The cable from the receive antenna is preferably routed through the wall of the shield via a bulkhead type of coaxial connector. If this is not possible, it may be routed through a shield door that is opened only far enough to pass the cable. If the open-door method is used, a check for direct coupling to the receiving equipment shall be made by putting a dummy load in place of the receive antenna and verifying that any signal present is at least 10 dB below the reference reading.

With horizontal polarization for both antennas (of either type), the receive antenna shall be moved vertically at least ± 0.5 m from the initial position. With vertical polarization for both antennas (of either type), the receive antenna shall be moved laterally at least ± 0.5 m from the initial position. Effects from nearby objects and personnel shall be minimized. The maximum reading shall be noted. The reference level shall be the maximum reading.

5.7.5 Detailed measurement procedure

The basic measurement procedure consists of positioning a transmit antenna outside the shield and a receive antenna inside the shield and measuring the magnitude of the largest received signal. The detailed procedures are the same for either type of antenna.

5.7.5.1 Transmitter configuration

Following the configuration in Figure 4, a series of transmit antenna positions shall be selected to cover various surfaces of the shield in accordance with the approved test plan (see 4.2). Horizontal polarization and vertical polarization shall be required. The horizontal spacing between transmit antenna positions shall be no larger than 2.6 m. If the reference measurement was at a distance of less than 2 m, then the maximum horizontal spacing shall be no more than 1.3 m. The center of the antenna shall be positioned at one-half the wall height above the floor, for walls less than or equal to 3 m high. If the height of the wall is more than 3.0 m, then multiple vertical positions for the transmit antenna shall be used. The vertical spacing shall be no more than 2.0 m, and the antenna shall be centered within each vertical segment. If the reference measurement was at a distance of less than 2 m, then the maximum vertical separation shall be no more than 1 m. The transmit antenna shall be positioned at least 1.7 m, less the thickness of the shield, from the test surface, and shall maintain at least 0.3 m clearance from the floor. If physical space limitations have resulted in a reference measurement at less than 2 m, then the transmit antenna shall be positioned at the reference distance minus 0.3 m.

The power to the transmit antenna shall be the same as used in establishing the reference level in accordance with 5.7.4.

5.7.5.2 Receiver antenna locations and data collection

The receive antenna shall be swept in position (throughout the shield interior) and to the greatest extent possible, in polarization, to obtain the largest detector response. The largest detector response shall be recorded for determining the (minimum) SE. A minimum spacing of 0.3 m from the shielding surface shall be maintained to the closest point of the antenna.

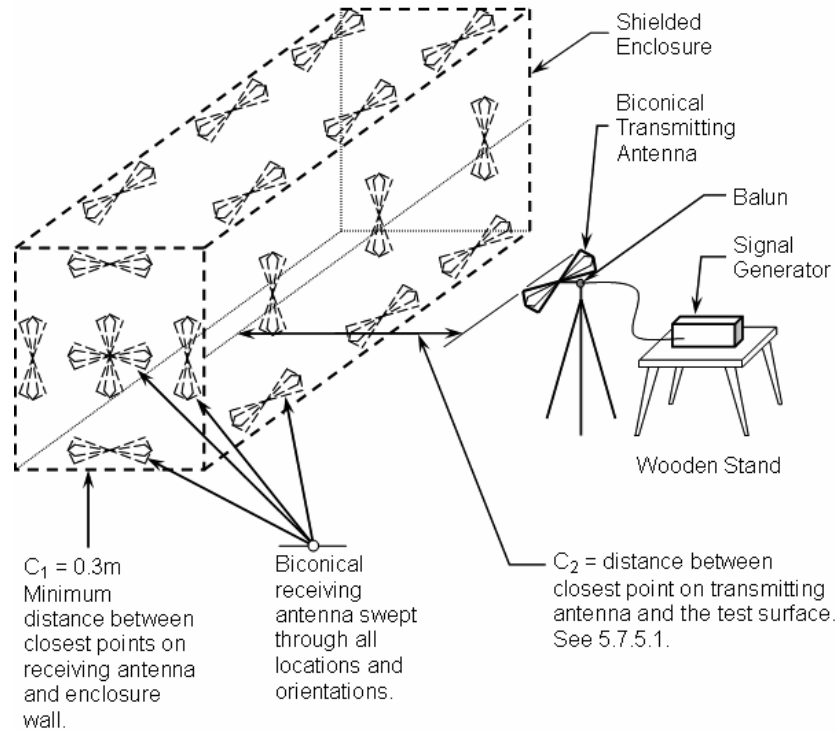

a) Measurement setup (horizontal transmitting antenna orientation), 20 MHz–100 MHz

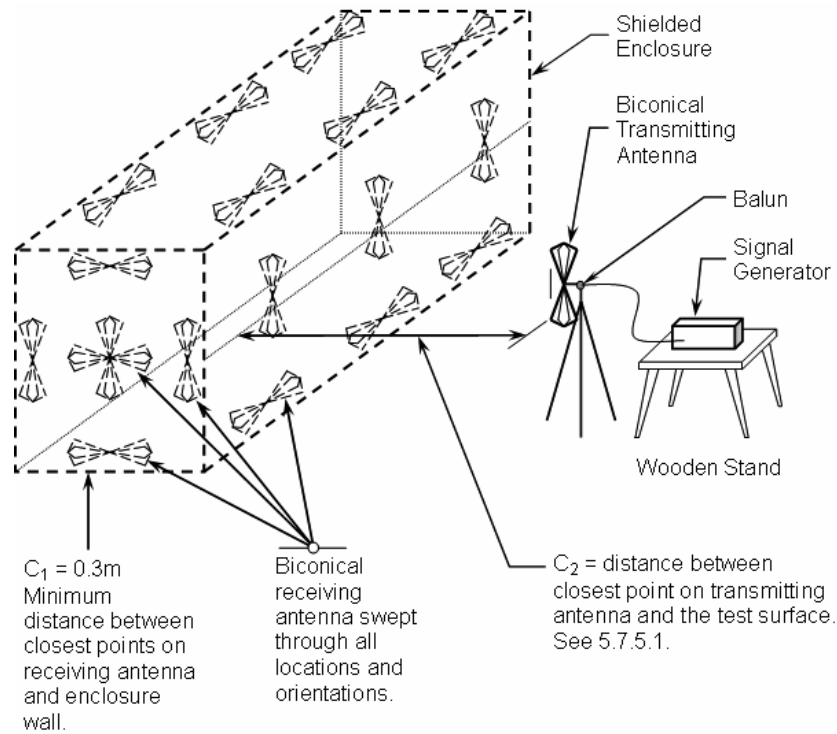

b) Measurement setup (vertical transmitting antenna orientation), 20 MHz–100 MHz

Figure 4—Schematic diagram of test configuration for resonant range tests

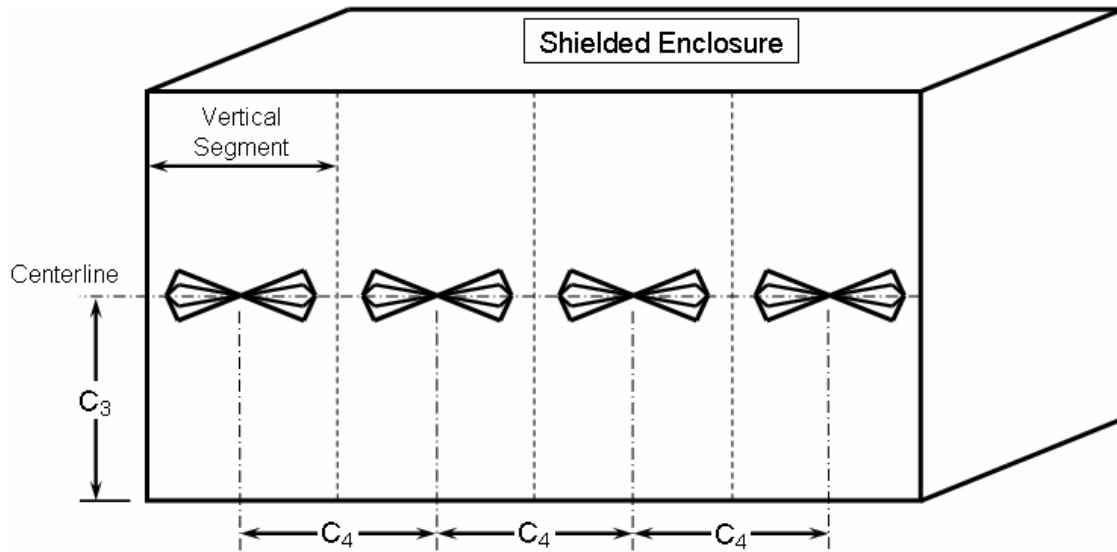

C_3 is the height of the transmit antenna
 $\frac{1}{2}$ wall height for walls $\leq 3\text{m}$

C_4 is the horizontal spacing between
 transmit antenna positions $\leq 2.6\text{m}$

**c) Transmitter configuration for measurement setup (horizontal antenna orientation),
 20 MHz–100 MHz**

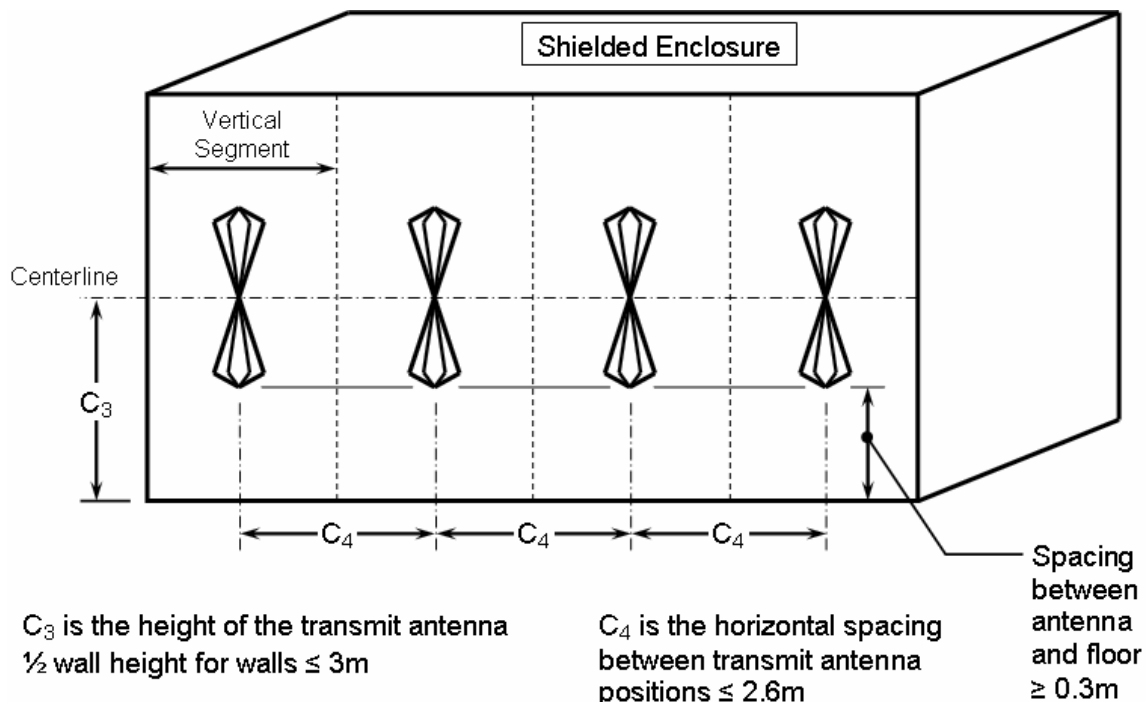

C_3 is the height of the transmit antenna
 $\frac{1}{2}$ wall height for walls $\leq 3\text{m}$

C_4 is the horizontal spacing
 between transmit antenna
 positions $\leq 2.6\text{m}$

Spacing
 between
 antenna
 and floor
 $\geq 0.3\text{m}$

**d) Transmitter configuration for measurement setup (vertical antenna orientation),
 20 MHz–100 MHz**

Figure 4—Schematic diagram of test configuration for resonant range tests (continued)

5.7.5.3 Determination of enclosure fundamental resonant frequency

The testing party shall calculate the approximate first resonant frequency, f_r , of the enclosure using the included equation or nomograph in Figure 5. This calculation shall be entered on the test data sheet(s). The relationship of the specified test frequency or frequencies to the first resonant enclosure frequency shall also be noted on the test data sheet(s). The relationship shall be expressed as a decimal part of f_r (see A.3.1).

For an enclosure of largest dimension a and next largest dimension b , the lowest resonant frequency in megahertz is approximately

$$f_r = 150 \sqrt{\frac{1}{a^2} + \frac{1}{b^2}}$$

This is plotted in Figure 5.

5.7.5.4 Test points

The procedure of 5.7.5.2 for the receive antenna shall be repeated for all transmitter locations and all frequencies, and for all shield surfaces in accordance with the method selected from the approved test plan (see A.4). Test personnel are encouraged to choose the order of test parameters (frequencies, antenna locations) to minimize the test time.

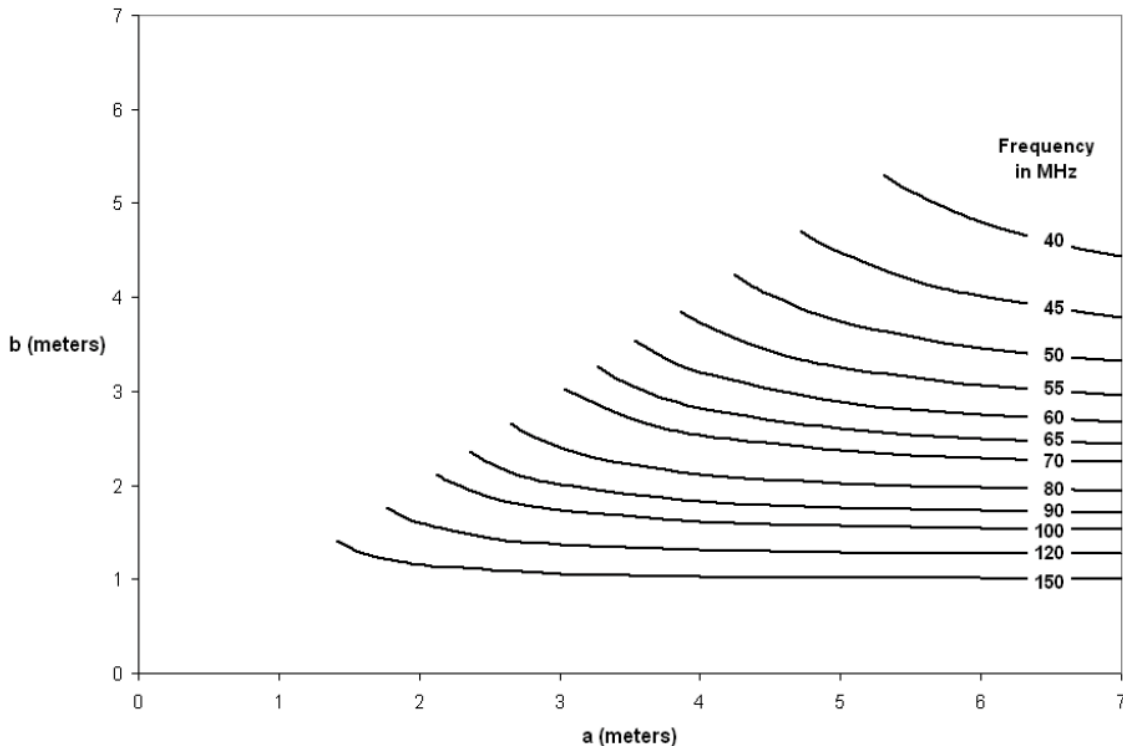

Figure 5—Lowest natural resonant frequency chart

5.7.6 Determination of resonant range shielding effectiveness

The SE shall be computed by Equation (B.3) or Equation (B.4) of Table 3, when linear units are used for measurement, or by Equation (B.5a), Equation (B.5c), or Equation (B.5d) of Table 3 when all meter readings are logarithmic (in decibels).

The following note shall be included with the test data: Electromagnetic SE measurements made at a single frequency in this range may not be representative of measurements made at other frequencies within the range. There may be significant variations due to resonance or other reflective condition effects.

5.8 High-frequency measurements (300 MHz to 18 GHz)

The high-frequency procedure directly measures the effect of high-frequency sources at positions over all accessible surfaces of the enclosure. The fields impinging on the shield shall be as planar as the relative wavelength and surrounding structure allows.

5.8.1 Frequency range and band

Subclause 5.8 provides a standard test procedure for the 300 MHz to 18 GHz range. Actual test frequencies shall be selected by the owner and included in the approved test plan. In all cases, the lowest test frequency in this procedure shall be at least three times the lowest cavity resonant frequency of the enclosure, as determined by the method in 5.7.5.3 and Figure 5.

Recommended frequencies for shielding measurements are a single frequency within each of the following bands: 300 MHz to 600 MHz; 600 MHz to 1 GHz; 1 GHz to 2 GHz; 2 GHz to 4 GHz; 4 GHz to 8 GHz; and 8 GHz to 18 GHz.

These procedures shall be extendable up to 100 GHz with the substitution of the appropriate equipment.

5.8.2 Test equipment and setup

Signal sources, measuring equipment, and arrangement shall be in accordance with 5.8.2.1, 5.8.2.2, Figure 6, Figure 7, and Figure 8.

5.8.2.1 Source of electromagnetic fields

The sources of EM fields shall be dipoles, biconical antennas, horns, yagis, log periodic, or other linear antenna types. A CW signal without modulation shall be used to drive the antenna.

To provide adequate DR, it may be necessary to use very high power ultra-high frequency (UHF)/microwave sources. Care shall be taken to limit personnel exposure to hazardous RF field levels.

WARNING

For all measurements undertaken as a part of this standard, care shall be taken to protect personnel from potentially hazardous RF field levels (IEEE Std C95.1-1999). This standard also suggests that authorization for transmit operation be obtained from the appropriate regulatory agency prior to activation of any transmitter. See C.3 of this standard for selecting measurement frequencies.

Care shall also be taken to avoid interference with other electronic equipment operating in the vicinity.

In all configurations, the effects of antenna transmission lines shall be considered. For example, when using linear dipoles, the connecting transmission line shall be run perpendicular to the antenna for at least one wavelength.

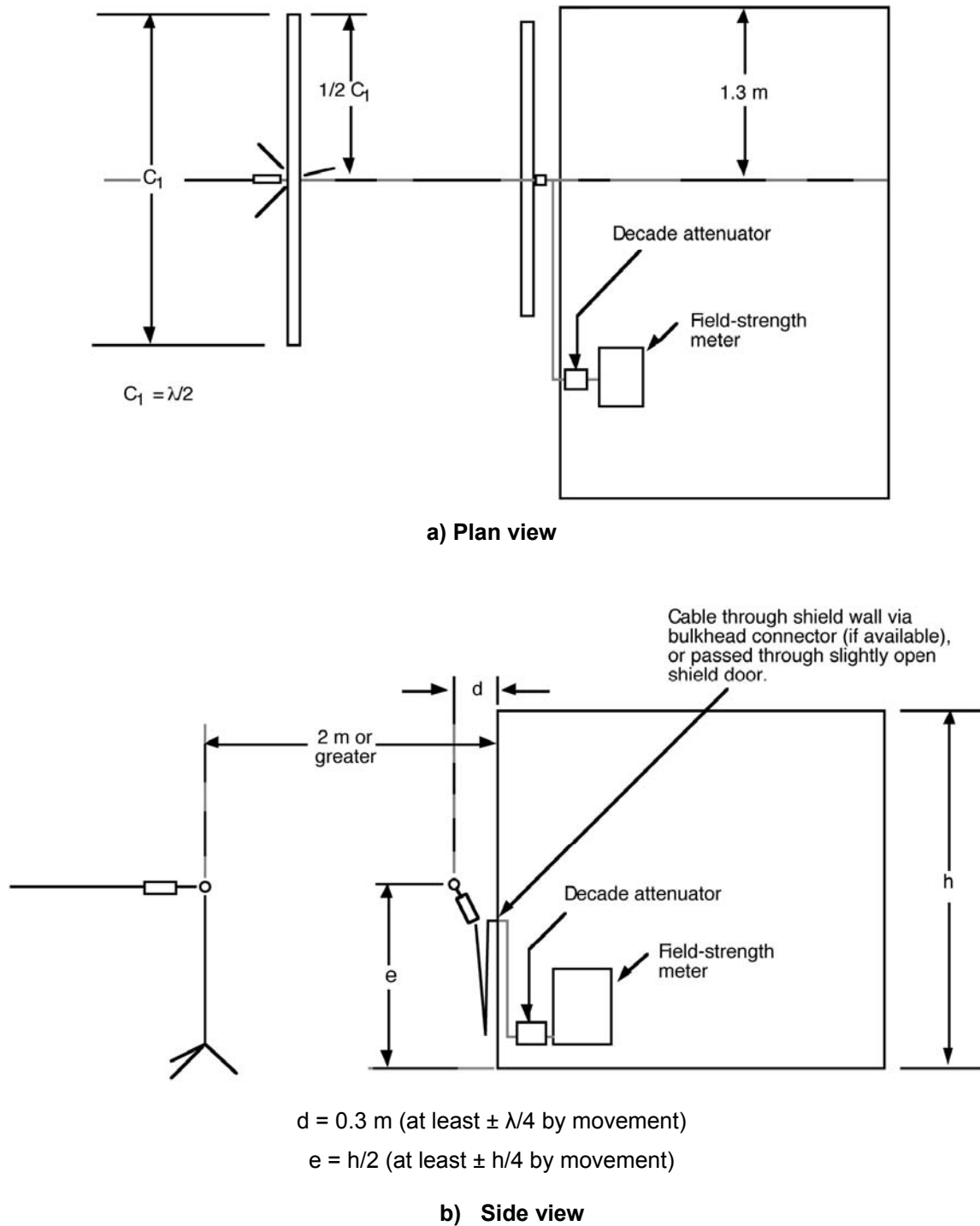
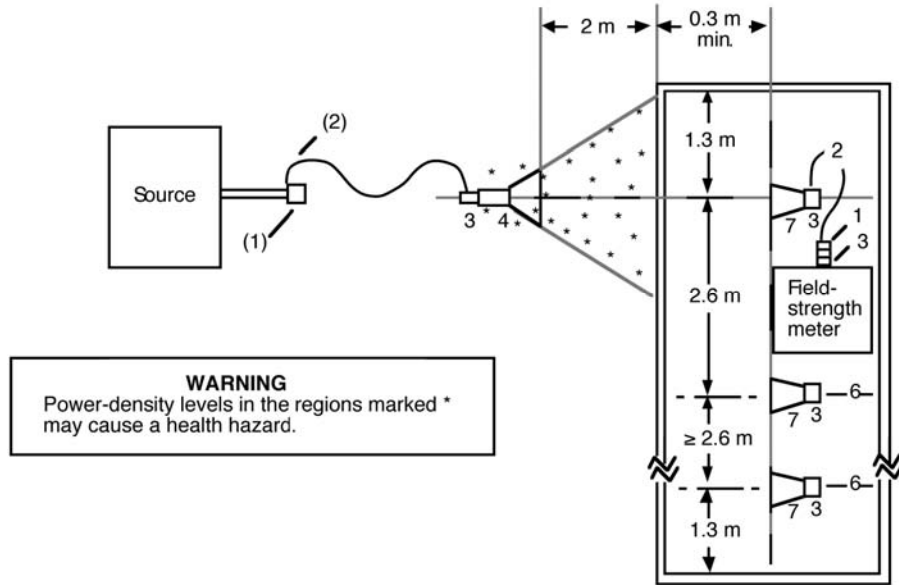
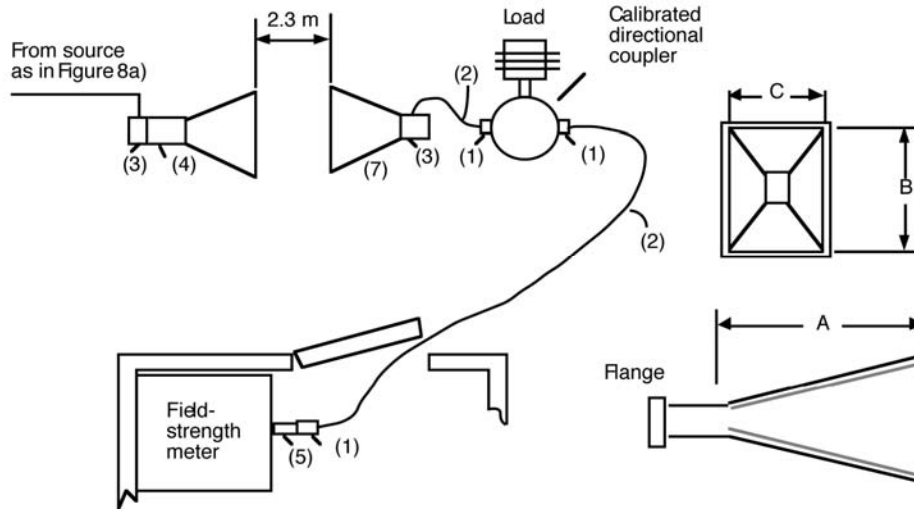

Figure 6—Reference setup for frequencies $\leq 1000 \text{ MHz}$



a) Broad-area microwave penetration



b) Enclosure free-field simulation

c) Standard gain horn dimensions

- NOTE 1—Type N adapter coax to waveguide (if needed).
 NOTE 2—Coaxial cable or waveguide.
 NOTE 3—Adapter (if needed).
 NOTE 4—Transmitter antenna (see Table 4) or ridged horn.
 NOTE 5—Attenuator (if not within field-strength meter).
 NOTE 6—Additional centerlines so that all areas are illuminated.
 NOTE 7—Receiving horn antenna [see Figure 8c) and Table 4]; dimensions related to standard EIA waveguides, flanges, and waveguide-to-coaxial transitions.

Figure 8—Reference and measurement setup for frequencies > 1 GHz

5.8.2.2 Detector of electromagnetic fields

The field-strength measuring device shall be a field-strength meter, a spectrum analyzer, or equivalent.

In the range 300 MHz to 1 GHz, an electric dipole whose overall length is $1/2 \lambda$ is required. Its output shall be connected through a balun transformer via coaxial cable to a field-strength measuring device. The cable shall be perpendicular to the axis of the dipole for a distance of at least 1 m.

A standard gain horn shall be used at frequencies above 1 GHz. For this standard, nonridged rectangular waveguide horn antennas shall be used. Typical horn dimensions are shown in Table 4.

Table 4—Dimensions and frequency ranges for horn antennas ^a

Frequency range (GHz)	Dimension A minimum (mm)	Dimension B (approximate) (mm)	Dimension C (approximate) (mm)
0.96–1.46	1033	632	475
1.12–1.7	883	534	402
1.7–2.6	416	340	260
2.6–3.95	400	235	175
3.95–5.85	264	157	116
5.85–8.2	200	116	86
8.2–12.4	126	76	58

^a See Figure 8c). The dimensions listed are intended for guidance in the event antennas will be self-constructed, or for use in selecting available commercial equivalents.

5.8.3 Preliminary procedures

Before formal testing, the testing organization is encouraged to test for leaks in the shield (and repair them) in accordance with the recommended procedures of Annex E. However, this preliminary check is not a mandatory part of the standard.

5.8.4 Reference measurement

Measurement of the reference level shall be made in accordance with 5.8.4.1, 5.8.4.2, Figure 6, and Figure 8.

5.8.4.1 Reference measurements for dipole antennas (300 MHz to 1 GHz)

The reference field without the presence of the shield is measured by the following method, which is designed to be conducted within typical facilities housing shielding enclosures and with a minimum reliance on long-term calibrations. See Figure 6.

The antennas shall be separated by a distance of 2 m, minimum, unless physical spacing limitations for either the reference level or SE readings preclude maintaining that spacing. In that event, maximum available separation shall be used, but shall not be less than 1 m, and that separation noted on the test report and data sheets.

The coaxial cable to the detector antenna (dipole) shall be kept perpendicular to the axis of the dipole for a distance of at least 1 m, except in the immediate vicinity of the shielding enclosure. The cable from the

receive antenna is preferably routed through the wall of the shield via a bulkhead type of coaxial connector. If this is not possible, it may be routed through a shield door that is only opened far enough to pass the cable. If it runs through the shield door, a check for direct coupling to the field-strength meter equipment shall be made by putting a dummy load in place of the receive dipole and verifying that any signal present is at least 10 dB below the reference reading.

With horizontal polarization for both antennas, the receiving dipole shall be moved vertically at least $h/4$ from the initial position. It shall also be moved $1/4 \lambda$ away from and towards the source. With vertical polarization for both antennas, the receive dipole shall be moved laterally at least one-fourth of the wall width. It shall also be moved $1/4 \lambda$ away from and towards the source. The maximum reading shall be noted and recorded as the reference level.

5.8.4.2 Reference measurements for horn antennas (> 1 GHz)

The reference measurement shall be made in accordance with Figure 8b).

The attenuator and Type N adapter, if used, associated with the field-strength meter shall remain within the enclosure, and the receive antenna shall be placed at a distance from the enclosure wall in such a way that both antennas can be colinearly located with a physical separation of 2 m, unless physical spacing limitations for either the reference level or SE readings preclude maintaining that spacing. In that event, the maximum available separation shall be used, but shall not be less than 1 m, and that separation noted on the test report and data sheets. A feed-through bulkhead connector, installed in the wall of the enclosure, may be utilized to connect the output of the directional coupler to the transmission line, which connects the antenna to the field-strength indicator during the penetration measurement.

The height of both antennas shall be approximately the same as will be used during the measurement procedure. The output of the receiving antenna is connected via suitable transmission line. During the recording period, the receiving antenna shall be moved at least $1/4 \lambda$ in all directions and the maximum amplitude recorded.

5.8.5 Detailed measurement procedures for high frequency

The basic measurement procedure consists of positioning a transmit antenna outside the shield and a receive antenna inside the shield and measuring the magnitude of the largest received signal. The detailed procedures are the same for dipole and horn antennas.

5.8.5.1 Transmitter configuration

Following the procedures in Figure 7 and Figure 8, a series of transmit antenna positions and polarizations shall be selected to cover various surfaces of the shield in accordance with the approved test plan (see 4.2).

Horizontal polarization and vertical polarization shall be required. The horizontal spacing between transmit antenna positions shall be no larger than 2.6 m. If the reference measurement was at a distance of less than 2 m, then the maximum horizontal spacing shall be no more than 1.3 m. The center of the antenna shall be positioned at one-half the wall height above the floor, for walls less than or equal to 3 m high. If the height of a wall is more than 3.0 m, then multiple vertical positions for the transmit antenna shall be used. The vertical spacing shall be no more than 2.0 m, and the antenna shall be centered within each vertical segment. If the reference measurement was at a distance of less than 2 m, then the maximum vertical separation shall be no more than 1 m. The transmit antenna shall be positioned at least 1.7 m, less the thickness of the shield, from the test surface, and shall maintain at least 0.3 m clearance from the floor. If physical space limitations have resulted in a reference measurement at less than 2 m, then the transmit antenna shall be positioned at the reference distance minus 0.3 m.

The power to the transmit antenna shall be the same as the power used in establishing the reference level in accordance with 5.8.4.

5.8.5.2 Receiver locations and data collection

The receiver antenna shall be swept in position (throughout the shield interior), in all directions of reception, and in polarization, to obtain the largest receiver response. The largest receiver response shall be recorded for determining the (minimum) SE. A minimum spacing of 0.3 m from the shielding surface to the closest point of the antenna shall be maintained.

5.8.5.3 Test points

The procedure of 5.8.5.2 for the receive antenna shall be repeated for all transmitter locations and all frequencies, and for all shield surfaces in accordance with the method selected from the approved test plan (see A.4). Test personnel are encouraged to choose the order of test parameters (frequencies, antenna locations) to minimize the test time.

5.8.6 Determination of shielding effectiveness

The SE shall be computed by Equation (B.4) of Table 3, when linear units are used for measurement, or by Equation (B.5a), Equation (B.5c), or Equation (B.5d) of Table 3 when all meter readings are logarithmic in decibels.

6. Quality assurance technical report

A technical report on the measurements performed shall be part of the requirements of this standard. However, the detail and the contents of the report shall be determined by the owner. Military users may use military standards or other detailed definitions of a test report at the owner's discretion. An abbreviated test report shall be the minimum reporting requirement of this standard.

All reports shall be typed. Equations and drawings may be done by hand if they are neat and legible.

6.1 Abbreviated test report

This report shall be prepared by the testing organization. As a minimum, the abbreviated test report should contain the following:

- a) Name of the owner organization
- b) Name of the testing organization
- c) Brief identification of test enclosure by name
- d) Location of test enclosure
- e) Name of test personnel
- f) Dates of test
- g) Frequencies tested
- h) Surfaces or faces tested
- i) SE measured

6.2 Full test report

If a full test report is to be prepared, it is recommended that the following content be included:

- a) All the information in the abbreviated test report

- b) Reference to procedures used for the test, diagram of the test setup(s), and conclusions from the test data (pass/fail)
- c) The material in 6.2.1, 6.2.2, and 6.2.3

6.2.1 Measurement procedure for full report

This is a description of the procedures followed for each part of the test, including, most importantly, how reference level and DR measurements were made. Locations of the test points shall be given.

6.2.2 Test instrumentation information for full report

Measurement instrumentation used shall be identified by manufacturer, model, serial number, calibration due date, and a copy of the calibration document (supplied by the agency that performed the calibration), if requested by the shield owner.

There shall be complete schematic diagrams for all the test setups that will enable a reader (an engineer) to understand how the equipment was connected.

6.2.3 Results for full report

This section shall include a full listing of test data. Included shall be copies of certified (signed) original data sheets or signed and change-protected electronic files of the original data, a complete description of the computational method for determining the SE, and the reference field level used during the test. Any modifications to standard procedures shall be fully detailed.

This section shall contain details of the test frequency selection process if the frequencies used were selected to avoid interference to locally assigned frequencies

This section shall include a full listing of the final SE values that have been computed for the shield.

Annex A

(informative)

Rationale

A.1 Basis

The basis for this standard is a well-defined measurement method that combines technical validity with a minimum of testing in order to constrain the effort and associated costs involved. Such constraint is achieved by the following considerations, listed as they apply to the objectives of 1.2.

A.2 Considerations pertinent to the objectives of 1.2

A.2.1 Standard measurements

- a) Measurement results within standard frequency ranges (Table 1) form a recommended uniform basis for comparing the performance of various shielding enclosures.
- b) Standard measurement locations include the following:
 - 1) Preselected seam or joint locations over the entrance wall.
 - 2) Accessible locations of shielding penetrations over all the shielding surfaces.

A.2.2 Preliminaries

- a) Prior to actual measurements, preliminary procedures are recommended to determine locations of poorest shielding performance. If such performance is inadequate, it may be improved before measurements of shielding performance are made.
- b) For the low-frequency range, a procedure to measure electric-field SE is not provided, since experience with most enclosures has shown that the most stringent requirement involves the effectiveness of magnetic-field shielding.

A.2.3 Nonlinearity

Nonlinear effects may be significant in the presence of strong emissions, producing a change in SE. Hence, an optional procedure to determine significant nonlinearities over a specified exposure range is included in Annex C of this standard.

A.2.4 Extended frequency range

Additional measurement results may be obtained by following the recommended procedures and using any nonstandard frequency within the following three frequency ranges:

- *Low*: 50 Hz to 20 MHz
- *Resonant*: 20 MHz to 300 MHz
- *High*: 300 MHz to 100 GHz

A.3 Cavity resonances

Measurements in the range of frequencies at which the lowest, or fundamental, cavity resonance can occur for most enclosures must consider variability of data. This frequency range is approximately $0.8 f_r$ to $3 f_r$, where f_r is the lowest cavity resonance frequency. Special precautions must be observed when testing in this range. Note that for very large enclosures, f_r may be lower than 20 MHz.

A.3.1 Cavity resonance considerations

A shielded enclosure constructed of electrically conducting walls will function as a resonant cavity. Under certain conditions, if EM energy is injected into the shielded enclosure, standing waves will exist for frequencies above the fundamental resonant frequency f_r . As a result of the standing waves, the EM fields are not uniform within the enclosure and exhibit maxima and minima that depend on the frequency of excitation.

The frequencies and modes at which a shielded enclosure is resonant are determined by the geometry or shape of the shielded enclosure and its dimensions. Shielded enclosures of almost any shape can resonate, but mathematical analysis is generally limited to relatively simple cases such as rectangular, cylindrical, and spherical enclosures. Most shielded enclosures are essentially six-sided rectangular enclosures (parallelepipeds).

A lossless, six-sided rectangular enclosure can support resonances for frequencies at the resonant frequency f_{ijk} :

$$f_{ijk} = \frac{1}{2\sqrt{\mu\epsilon}} \sqrt{\left(\frac{i}{a}\right)^2 + \left(\frac{j}{b}\right)^2 + \left(\frac{k}{c}\right)^2} \quad (\text{A.1})$$

where

- μ is the permeability inside the enclosure
- ϵ is the permittivity inside the enclosure
- a is the longest dimension of the enclosure in meters
- b is the intermediate dimension of the enclosure in meters
- c is the shortest dimension of the enclosure in meters

such that $a > b > c$ and $i, j, k =$ a positive integer 0, 1, 2, 3...; however, not more than one of i, j, k can be zero at the same time.

Under ideal conditions, the resonant frequency in MHz is given by

$$f_{ijk} = 150 \sqrt{\left(\frac{i}{a}\right)^2 + \left(\frac{j}{b}\right)^2 + \left(\frac{k}{c}\right)^2} \quad (\text{A.2})$$

Thus, the *lowest* resonant frequency for this shielded enclosure is calculated from

$$f_r = f_{110} = 150 \sqrt{\left(\frac{1}{a}\right)^2 + \left(\frac{1}{b}\right)^2} \quad (\text{A.3})$$

which is obtained by using indices $i = 1$ and $j = 1$ for the two longest dimensions, a and b , and using index $k = 0$ for the shortest dimension, c .

In principle, a shielded enclosure can sustain cavity resonances if $f \geq f_r$ and a shielded enclosure cannot sustain cavity resonances if $f < f_r$. For the minimum size shielded enclosure with $a = b = c = 2$ m all three of the lowest-order modes (e.g., TM_{110} , TE_{011} , and TE_{101}) are degenerate and have the same resonant frequency:

$$f_r = f_{110} = 150 \sqrt{\left(\frac{1}{2}\right)^2 + \left(\frac{1}{2}\right)^2} = \frac{150\sqrt{2}}{2} = 106 \text{ MHz} \quad (\text{A.4})$$

This is the highest fundamental frequency because larger enclosures will have a lower f_r .

The energy loss in a cavity is described by a quality factor, Q , which is the ratio of the energy stored to the energy lost per cycle. The energy loss in an empty shielded enclosure is a function of the electrical conductivity of the metal walls; therefore, minimum losses occur when highly conducting materials such as copper are used. Any material within the cavity that has a loss factor greater than air will increase the losses.

A.3.2 Slot resonance considerations

There are resonance effects other than cavity resonances that may affect the measured SE of the shielded enclosure. One such phenomenon is slot resonance. The penetration of EM fields through a given slot in a conducting plane varies with frequency. Slot resonance may occur at frequencies below the fundamental resonance frequency f_r for cavity resonance.

These resonance effects are inherent in the EM performance of the shielded enclosure and are not artifacts of the test technique; consequently, such resonance effects should be considered, as is the case with cavity resonance effects.

A.3.3 Procedural cautions

Empirical tests demonstrated that interconnecting cables between the antenna and detector do interact with existing fields in the enclosures and can have a significant effect on the measured SE values. For this reason, the use of antennas with baluns and cables employing ferrite loading have been mandated to minimize these effects. It is suggested that the tester use only the one longest length of connecting cable necessary for testing inside of a given shielded enclosure. Using varying cable lengths can produce different measurement values within the same given enclosure and may make repeatability of results more difficult to achieve. The length of the cable used should be included in the test report.

Due to the nature of resonance effects, if there is reason to believe that such effects are a significant factor in the measured SE values of a shielded enclosure undergoing evaluation, then it may be necessary to perform either a frequency sweep (source and detector) from some point below the frequency of interest to some point above it. Alternatively, a series of discrete stepped frequencies may be used to reduce uncertainty and improve the confidence level of the measurement. An effect should be considered significant if variations of apparent SE value greater than 3 dB occur over this limited frequency span.

In general, resonant effects will be minimal below $0.8 f_r$. Whenever possible, tests within this range should be conducted at or below 0.8 (80%) of the calculated fundamental resonant frequency for the given enclosure.

The performance of the receiving antenna can be affected by being located too close to the enclosure metallic wall. Refer to Figure A.1 for guidance in positioning the receive antenna while making measurements.

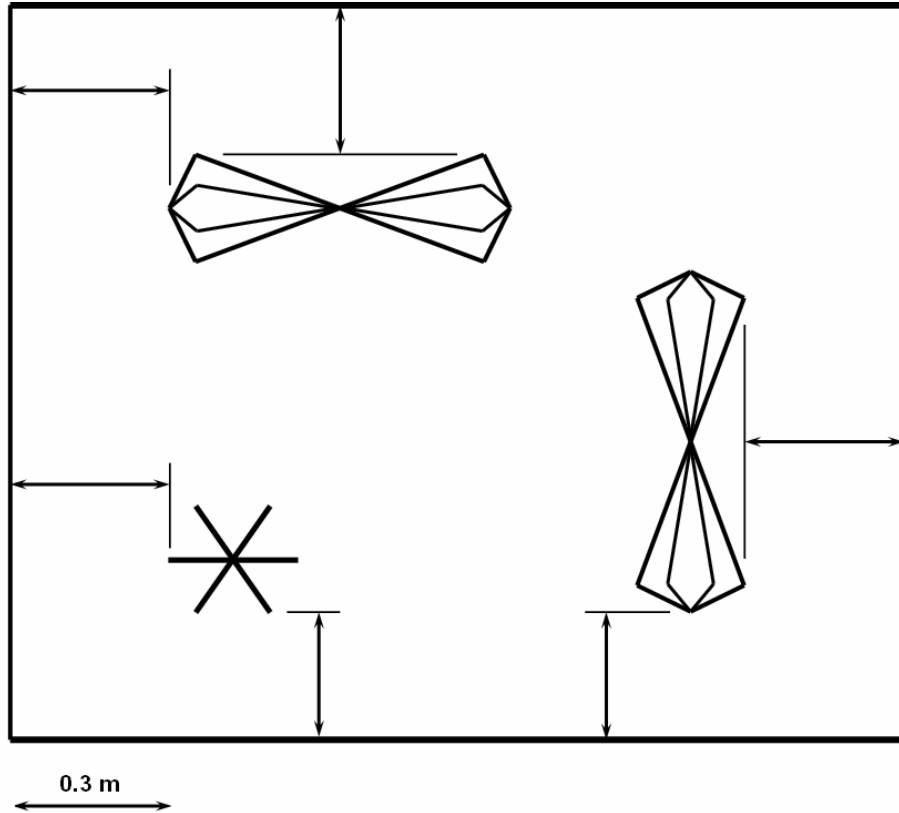

Figure A.1—Minimum spacing from closest tip of antenna to shielded enclosure wall

In complex cavities, such as shielded enclosures excited at high frequencies (as defined in this standard), the directivity characteristics of the antenna are lost. This, along with the enhancement of the fields by the quality factor or Q of the enclosure, results in the incorrect measurement of the fields within the enclosure. The definitions for SE given in this standard do not account for complex field conditions. Instead, this standard requires the use of standard gain antennas in order to obtain a consistent measurement methodology for obtaining and comparing the SE of enclosures.

If correction for these effects is desired, then Equation (A.5) and Equation (A.6) can be used to calculate E_1 and E_2 for use in the equations contained in Table 3.

$$|E_1| = \sqrt{377 \times 4\pi P_r / \lambda^2 G} \quad \text{V/m reference measurement} \quad (\text{A.5})$$

$$|E_2| = \sqrt{377 \times 8\pi P_r / \lambda^2} \quad \text{V/m enclosure measurement} \quad (\text{A.6})$$

where

- P_r is the power received in watts
- λ is the wavelength in meters,
- G is the numeric antenna gain

NOTE—The enclosure measurement assumes a free space impedance of 377Ω as has been presented in several National Institute of Standards and Technology (NIST) Technical Notes. Work by NIST⁹ suggests that this is a close approximation. Subsequent work at NIST (detailed in a Correction Note to NBS TN1092¹⁰) suggests that the maximum amplitude of the fields within the enclosure is more accurately predicted by using the average of the field magnitude. Some field level compression has been noted below about 1 GHz, and therefore this newer method may not be fully applicable in a general case. Use of the above expression for E_2 will yield an approximation within about 1 dB of the value obtained by assuming an impedance of 377Ω .

A.4 Measurement locations

A.4.1 Locations for measurement around device under test (DUT)

Often, enclosures installed in buildings have one or two walls, in addition to the floor and/or ceiling, inaccessible for measurement purposes. Thus, making measurements along all surfaces of a shielded enclosure, although conceptually desirable, is impractical. A practical approach would be to measure all accessible surfaces. In considering economics, this would penalize the more accessible enclosure by requiring more measurements than a similar enclosure installed in a more restricted area. Practical field testing at the higher frequencies has shown that external reflections of RF energy can penetrate a poor seam or joint on the nonaccessible side(s), resulting in reduced overall SE for the enclosure. Therefore, these areas must be checked in at least a nondirect illumination manner to verify the absence of significant leaks. For the vast majority of enclosures, all the walls containing entrance doors are accessible, and are to be measured at specific locations by this standard.

In the case of enclosures having architectural treatments (including, but not limited to, drywall and/or insulation without metal backing, acoustical absorber, and studding, either wooden or metallic) that either partially or fully encase the entrance door wall, measurements shall be taken in accordance with the applicable procedure for the frequency range and the transmit and receive probes spaced to include the architectural treatments as part of the shield. Since entrance walls may not include all penetrations, measurements limited to entrance walls might not provide an equitable basis for determining the SE of all enclosures. Hence, all accessible wall areas in the immediate vicinity of penetrations are also required to be measured. (To the extent that some penetrations are inaccessible, the concept of indirect, reflective checks may be necessary to confirm the absence of leakage at penetrations that are not externally accessible.) Standard measurement locations are summarized in item b) of A.2.1.

A.4.2 Effects of measurement location

Signal source area reflections exist with broad antenna apertures. When testing in non-anechoic enclosed locations, it is good practice, if possible, to establish a baseline reference response curve for that location without the DUT present. If this cannot be done, comparable DUT data acquired in an ideal test location may define response variations.

A.5 Measurement equipment

Test procedures have been formulated as follows: 1) to enable the use of commercially available equipment for conducting tests under less-than-ideal conditions (such as within typical facilities used to house the shielding enclosure) and 2) to minimize changes in internal impedance of the antenna (due to proximity to the shield) from affecting the data measured.

⁹ NIST publications are available from the Superintendent of Documents, U.S. Government Printing Office, Washington, DC 20402-9325 USA (<http://www.nist.gov/>).

¹⁰ NBS TN 1092, April 1986, *Design, Evaluation and Use of a Reverberation Chamber for Performing Electromagnetic Susceptibility/Vulnerability Measurements*, Crawford, M. L., and Koepke, G. H.

Annex B

(informative)

Mathematical formulas

B.1 Specific mathematical formulations

In general, fields penetrating a shielding enclosure arise from both the electric and magnetic components of the EM energy impinging upon the enclosure. If the penetrating electric and magnetic fields are measured separately, each can be demonstrated to be a function of the impinging wave. In addition, the wave impedance of an applied field is radically altered upon penetrating an enclosure, and the measurements may be affected by the position of the sensor; measurement results may be sensitive to the test procedure details, unless the details are closely controlled. As a result, specific definitions for measures of enclosure performance are set forth in this annex for each associated measurement procedure.

B.2 Low-range (50 Hz to 20 MHz) shielding effectiveness

In the low range of frequencies (50 Hz to 20 MHz), the form for expressing SE is in terms of magnetic field performance¹¹ is given in the following equation:

$$SE_H = 20 \log_{10} \frac{|H_1|}{|H_2|} \text{ (dB)} \quad (\text{B.1})$$

where

H_1 is the magnetic field measured using the antenna placed in the prescribed configuration in the absence of the enclosure (reference reading)

H_2 is the magnetic field measured using the antenna placed in the prescribed configuration within the enclosure

When the meter readings V_1 and V_2 are, respectively, proportional to H_1 and H_2 (the usual measurement situation), a more convenient form for Equation (B.1) is given as follows:

$$SE_H = 20 \log_{10} \frac{|V_1|}{|V_2|} \text{ (dB)} \quad (\text{B.2})$$

where

V_1 is the voltage reading in the absence of the enclosure (reference reading)

V_2 is the voltage reading within the enclosure

When nonlinear (i.e., logarithmic) measurement units are used, such as dBm or dB μ A, Equation (B.5a) or Equation (B.5b) may be used to directly derive SE.

¹¹ These expressions apply only to the specific measurement procedures described in Clause 5.

B.3 Resonant range (20 MHz to 300 MHz) shielding effectiveness

In the resonant range (20 MHz to 300 MHz), the form for expressing SE may be either in electric field terms or power terms, given by the following equation:¹²

$$SE_E = 20 \log_{10} \frac{|E_1|}{|E_2|} \text{ (dB)} \quad (\text{B.3})$$

where

E_1 is the electric field measured using the antenna placed in the prescribed configuration in the absence of the enclosure (reference reading)

E_2 is the electric field measured using the antenna placed in the prescribed configuration within the enclosure

or by

$$SE_P = 10 \log_{10} \frac{P_1}{P_2} \text{ (dB)} \quad (\text{B.4})$$

where

P_1 is the power detected in absence of the enclosure (reference reading)

P_2 is the power detected within the enclosure

When nonlinear (i.e., logarithmic) measurements are used, such as dBm, dB μ V, or dBmW, Equation (B.5a) through Equation (B.5d), as appropriate, may be used to derive SE directly.

B.4 High-range (300 MHz to 100 GHz) shielding effectiveness

For the high range (300 MHz to 100 GHz), SE is expressed using Equation (B.3),¹³ Equation (B.4),¹⁴ or Equation (B.5d).

B.5 Nonlinear (logarithmic) calculations

The SE may be directly derived using the following expressions whenever measurements have been made using nonlinear units:

$$SE_E = |E_1| \text{ (dB)} - |E_2| \text{ (dB)} \quad (\text{B.5a})$$

$$SE_H = |H_1| \text{ (dB)} - |H_2| \text{ (dB)} \quad (\text{B.5b})$$

$$SE_V = |V_1| \text{ (dB)} - |V_2| \text{ (dB)} \quad (\text{B.5c})$$

$$SE_P = P_1 \text{ (dB)} - P_2 \text{ (dB)} \quad (\text{B.5d})$$

¹² These expressions apply only to the specific measurement procedures described in 5.7 and/or 5.8.

¹³ See Footnote 11.

¹⁴ See Footnote 11.

where

E_1 , H_1 , V_1 , or P_1 is the reference electric field, magnetic field, voltage, or power intensity measured without the enclosure (in dB μ V/m, dBT, dBV, or dBm)

E_2 , H_2 , V_2 , or P_2 is the electric field, magnetic field, voltage, or power intensity measured with the enclosure in place (in dB μ V/m, dBT, dBV, or dBm)

B.6 Dynamic range considerations

DR of a test system is determined by the strength of the exciting signal, the performance of associated transmit and receive antennas, cable losses, attenuator and/or preamplifier performance, and the noise floor of the receiving instrument. As a practical matter, there is usually sufficient signal source power available for general applications (testing of enclosures with expected SE > 120 dB may require higher transmit power). The passive antennas required by this standard will not measurably affect the DR of the system. Finally, except for long cables that may be required for testing very large enclosures, cable losses are not significant up to about 1 GHz. Thus, the receiving instrument and any preamplifiers become the important consideration in determining DR.

Modern receiving instruments typically exhibit noise floors below -120 dBm when filters of < 30 kHz bandwidth are in use. The critical issue for DR, then, is maximum signal into the instrument without causing nonlinearity (gain compression), which will skew reference level readings and affect SE values. The DR of the receive system (receiving instrument plus any external attenuators) is the difference between the largest possible input signal (usually defined as being at the 1 dB compression point) and the noise floor (which limits the minimum detectable signal). The DR for a receiver is expressed in decibels. Thus

$$DR_{\text{RCVR}} = P_1 \text{ (dB)} - P_2 \text{ (dB)} \quad (\text{B.6})$$

where

P_1 is the minimum input signal that causes 1 dB compression (including internal and/or external attenuators)

P_2 is the instrument minimum detectable signal (usually the noise floor) at the frequency and filter bandwidth to be used

For purposes of determining DR for this standard, only an upper bound is needed, and DR must only exceed anticipated SE by 6 dB. This means that the absolute DR, as determined above, does not need to be measured for an SE test unless a very high SE is expected for the enclosure. As long as the receiving system is linear using the transmit power levels of actual testing during reference level measurement, and the DR (considering the receiver noise floor) exceeds the SE requirement by at least 6 dB in actual testing configuration, the requirements of this standard have been met.

Annex C

(informative)

Miscellaneous supporting information

C.1 Coplanar versus coaxial loops

Significant differences exist between currents excited on a shield surface by coplanar and coaxial loops. Coplanar loops cause current flow in the shield to be concentrated in one line lying in the plane of the loops. Coaxial loops cause current flow in the shield to be concentrated in the geometric shape of a circle parallel to the exciting loop. Three measurement considerations result from these differences as follows:

- a) *Location precision.* Defects at seams can be located more precisely from a current flow across the seam (coplanar case) than from a double current flow (coaxial case), which is especially important in the presence of multiple defects.
- b) *Loop impedance.* The input impedance of a coaxial loop changes more drastically than a coplanar loop in the following two measurement situations: 1) in the presence of a shield and 2) away from the shield. A resulting effect on the source field strength is overcome in the measurement procedure by maintaining the same current in the source loop for the measurement situations (see 5.6.5).
- c) *Source power.* The power required to drive the source loop is less in the coaxial case than in the coplanar case due to tighter loop-to-loop coupling.

The use of coplanar loops is advocated in this standard on the basis of their precision in locating defects and in measuring their effects.

Unshielded loop antennas generate and/or receive both magnetic and electric fields. Since the low-frequency electric field component is reduced significantly more than the magnetic component, artificially high (4 dB to 10 dB) SE measurements are obtained with unshielded loops. Only electrostatically shielded loop antennas shall be used for this standard.

C.2 Nonlinearity of high-permeability ferromagnetic enclosures

Very intense magnetic fields may saturate magnetic materials and cause inaccurate magnetic field measurements. Nonlinearity effects may be determined by placing source and receiving loops on opposite sides of a panel near geometric center (as shown in Figure 1), and measuring the magnetic SE as a function of source strength. Generator output shall be increased in 10 dB steps, nominally 0.1 W to 1 W and 10 W. If the magnetic SE decreases more than about 2 dB, then intermediate level measurements shall be made. The results shall then be plotted to determine the highest level permissible for linear performance (within ± 1 dB).

C.3 Selecting measurement frequencies

C.3.1 Regulatory note

Transmitter operation should be authorized by the appropriate regulatory agency. Permission from the appropriate regulatory agency should be obtained before activating any transmitter.

In many cases transmitting equipment must be operated only under the supervision of the holder of an appropriate class of operator's license; thus, if a licensed operator is not already a member of the testing staff, a staff member should obtain such an operator's license.

C.3.2 Selecting frequencies

A table of frequency allocations from the appropriate regulatory agency should be studied to select frequencies that are most likely to be approved. In general, frequencies will probably be approved where no interference to other licensed radio services is likely to occur. The length of time each frequency will be used should always be stated. If frequencies are to be used intermittently, that is, for periods of only a few minutes at a time only a few times per hour, they are more likely to be approved. Under intermittent use, interference tends to be minimized, and the regulatory agency may approve intermittent use of frequencies for which continuous use could not be approved. It is advisable to keep the request in the business, industrial, and petroleum radio-service frequencies.

Frequencies to avoid include the following:

- In general, the domestic public radio service frequencies should be avoided, since this service is protected. Police and fire frequencies should also be avoided.
- The exact frequency of a commercial broadcast station should be avoided if there is a reasonable chance that interference will occur.
- The following frequencies should not be requested: on or within the guard bands, or any emergency frequencies in any of the VLF, LF, MF, or HF radio navigation channels that may be active at or near the test locations.
- Government frequencies should be avoided. If government frequencies are needed, the local area frequency coordinator should be contacted through the nearest military base communications officer. Early establishment of rapport with the area frequency coordinator is beneficial in any situation. If the coordinator is satisfied that there will be no harmful interference to the government radio services for which he or she is responsible, he or she will likely help obtain license authorization for government frequencies.
- Standards frequencies, such as those used by WWV, CHU, U.S. Naval Observatory, and other international time and frequency stations, should be avoided. Radio-astronomy frequencies that are active in or near the test area should also be avoided.

All requests should be for discrete frequencies. A request for a band of frequencies should include a justification of why discrete frequencies cannot be used.

C.3.3 Suggested measurement frequencies

Suggested frequencies for susceptibility test use are shown in two lists. The first list (Table C.1) consists of authorized frequencies (within the United States) for instrument, scientific, and medical (ISM) and field disturbance sensors (FDS).

Table C.1—United States ISM and FDS frequencies

Kilohertz	Megahertz
6 780 ± 15	915 ± 13
13 560 ± 7	2 450 ± 50
27 120 ± 163	5 800 ± 75
40 680 ± 20	24 125 ± 125

The test frequencies of Table C.2 are spaced unevenly throughout the spectrum to avoid conflict with known unapprovable frequencies. Some of these suggested frequencies may not receive approval in all countries.

Table C.2—Suggested test frequencies for the 9 kHz to 18 GHz range

Kilohertz	Kilohertz	Megahertz	Megahertz	Megahertz	Gigahertz
10.0	111	1.0 ^a	13.56	130	1.29 ^b
14.0	130	1.3 ^a	16.00	160	1.86
16.0	160	1.995	20.02	209	2.1 ^b
20.5	200	2.6	27.12	260 ^c	2.45
25	250	3.2	33.30	327 ^c	3.29
32	326	4.06	40.68	415 ^c	4.19
40	400	5.1	52	523 ^a	5.80
50	520	6.525	65 ^a	661 ^a	6.6
64	640 ^a	8.1	81 ^a	830	8.4 ^b
80	810 ^a	10.1	100 ^a	915	10.495 ^b
					13.22
					18

NOTE—For test frequencies in the resonant range, apply the procedure described in 5.7.1.

^a These frequencies are in the broadcasting bands. Check to see if the listed frequencies are occupied, and, if so, select a nearby locally nonallocated frequency.

^b In some cases, these are shared government/nongovernment frequencies; thus, some problem in assignment of these frequencies may occur.

^c These frequencies may be part of a government band and, therefore, may not be assignable or authorizable. The local area frequency coordinator (or equivalent authority) may be able to assist in selecting frequencies.

Annex D

(informative)

Guidelines for the selection of measurement techniques

D.1 Types of enclosures

Shielded enclosures may be categorized generally by the following three criteria:

- Method of construction
- Shielding material
- Intended application

Method of construction refers to such factors as, but is not limited to, single shield, double shield (cell), double electrically isolated shield (DEI), bolted modular, fixed location or demountable configuration, and welded techniques. The shielding material may consist of, but not be limited to, copper (solid or screen), steel (sheet or plate), aluminum, and a variety of metallized fabrics or similar substrates. Applications may include, but not be limited to, anechoic chambers for military specification compliance testing, semianechoic chambers for commercial EMC compliance testing, mode-stirred chambers, R&D experimental applications, commercial production or repair facility for RF equipment, medical imaging and treatment facilities, and scientific experimental facilities.

The correct and cost-effective application of this standard requires that the previous criteria be considered when selecting which test procedures and which test frequencies will be used for any given shielded enclosure requirement. In some cases, special techniques, such as frequency sweeping, may be required. Refer to Annex A and Annex B for details. Some application examples are as follows:

- A welded steel enclosure to be used for military application would most likely be specified for testing in each of the frequency ranges and have a high level of SE (nominally > 100 dB).
- A single copper shield, bolted together in panel sections and intended for medical MRI applications, would most likely be tested only in the resonant range and be required to have a SE in the range of 80 dB to 100 dB.
- A steel cell structure to be used for test and repair of VHF and UHF radio equipment would most likely be tested only in the high range.
- A portable, collapsible test cell for field applications and made of metallized fabric or screening would most likely require a low performance level in the resonant and/or high ranges.

D.2 Performance requirements

Shielded enclosures are generally specified with some shielding performance requirement at the time they are designed, ordered, or built. The purpose of this standard is to provide a uniform test method for all enclosures meeting the criteria of 1.2. The selection and application of methods described herein is the responsibility of the parties associated with the enclosure: principally the owner and the owner's representatives. It would not be possible to fully test in accordance with this standard if the standard requires procedures or techniques that are inappropriate or incompatible with the particular enclosure involved.

D.3 Equipment requirements

It is the intent of this standard that test equipment used to measure shielding performance be appropriate for the application. The individual sections for each of the techniques and frequency ranges determine the general equipment and antenna probes needed. It is the responsibility of the associated parties to ensure that adequate frequency and DR are available. This standard requires that the measurement system have a usable DR that is no less than 6 dB greater than the specified or expected shielding performance of the enclosure. Available technology will vary over the applicable frequency range of this standard, and it is expected that judicious use of RF power amplifiers and preamplifiers will be made as needed.

D.4 Regulatory agency conflicts

Due to regulatory limits on transmitting in some frequency bands, outside-in tests (with transmit antenna on the outside and receive antenna on the inside) may be prohibited. In this case, inside-out testing (with transmit antenna on the inside and receive antenna on the outside) may be required; however, the following issues need to be considered:

- a) The reference field test procedures are done in the existing manner, but must be done quickly because open transmitting is required.
- b) Once the chamber door is closed, cavity effects on the “net” reference level need to be considered. This is especially important for test frequencies near and above the fundamental resonant frequency of the chamber.
- c) Revision/change of the test placement figures is required to correctly depict this test arrangement. Test placement figures depicting the actual test arrangement should be included in the test report. Test personnel who must employ inside-out testing should carefully study the existing test point location figures and modify them accordingly. All test locations should be noted in the test documentation.
- d) Accessibility to floors and other surfaces that may be partially or fully blocked will limit the extent to which leakage points may be determined.
- e) Measure and record the outside ambient signal level at all proposed test frequencies prior to start of testing.
- f) Use of the inside-out technique may significantly limit the selection of test frequencies due to high ambient noise levels.

Annex E

(informative)

Preliminary measurements and repairs

It may be that the shield requires minor, and possibly major, repairs before the SE measurements are made. For reasons of efficiency, it is recommended that the shield receive a cursory check before the final SE measurements are made in accordance with Clause 5. This annex contains a recommendation for procedures to perform this check. A cursory check is not required by the standard, however.

E.1 Background

Preliminary check procedures, while not mandatory, are provided as a standardized reference whenever it is decided that performing a preliminary scan may be beneficial, particularly in identifying areas of significant leakage prior to taking formal SE data.

E.2 Frequencies for preliminary check

The procedures of this annex are for the normal range of frequencies, and they may also be applied to the extended range.

For the low range of frequencies (9 kHz to 20 MHz), small magnetic loops (typically less than 1 m in diameter) are useful as source and sensor antennas; in the resonance range (20 MHz to 300 MHz), biconical and electric dipoles are recommended; and in the high range (300 MHz to 18 GHz) dipoles, horns, or equivalent antennas can be used.

To provide a means for measuring performance of enclosures, single-frequency measurements should be made in accordance with the test plan (see 4.2) using any of eight fairly narrow bands as required: 9 kHz to 16 kHz, 140 kHz to 160 kHz, 14 MHz to 16 MHz, 50 MHz to 100 MHz, 300 MHz to 400 MHz, 600 MHz to 1000 MHz, 8.5 GHz to 10.5 GHz, and 16 GHz to 18 GHz. (Test frequencies unique to the specific installation should also be considered.)

WARNING

For all measurements undertaken as a part of this standard, care shall be taken to protect personnel from potentially hazardous RF field levels (IEEE Std C95.1-1999). This standard also suggests that authorization for transmit operation be obtained from the appropriate regulatory agency prior to activation of any transmitter. See C.3 of this standard for selecting measurement frequencies.

Care shall also be taken to avoid interference with other electronic equipment operating in the vicinity.

E.3 Preliminary check procedures

Prior to making any preliminary scan or measurement, the signal measuring device shall be tested for signal penetration of its case.

Ancillary equipment (such as blowers and fans) normally present during operation of the enclosure shall remain in place during the test. Other equipment that is not a normal part of the enclosure shall be removed prior to test.

The transmitting and receiving antennas should be positioned roughly as shown for the various tests in Clause 5 (see Figure 1, Figure 2, Figure 4, Figure 7, and Figure 8); however, for the preliminary check it is

recommended that the antennas be located and oriented to produce the largest response possible. A scan should be made along all accessible shielding faces to detect areas of poor performance prior to actual measurement.

Items that should be checked are doors, power-line filters, air vents, seams, coaxial cable and waveguide fittings, emergency egress panels for personnel, and fluid piping penetration points.

Based on the results of these measurements and the sizes of the observed leaks, the owner and testing organization can then decide whether to proceed with full SE testing or have repairs made before full SE.