

A M E R I C A N N A T I O N A L S T A N D A R D



ANSI C57.12.20-1997

AMERICAN NATIONAL STANDARD

**FOR TRANSFORMERS-
STANDARD FOR OVERHEAD TYPE
DISTRIBUTION TRANSFORMERS,
500 kVA AND SMALLER:
HIGH VOLTAGE, 34500 VOLTS AND
BELOW;
LOW VOLTAGE, 7970/13800Y
VOLTS AND BELOW**



**NATIONAL ELECTRICAL MANUFACTURERS ASSOCIATION
1300 NORTH 17TH STREET, SUITE 1847, ROSSLYN, VA 22209
(703) 841-3200 FAX: (703) 841-3300**

ANSI C57.12.20-1997

AMERICAN NATIONAL STANDARD

for Transformers—

**Standard For Overhead Type Distribution Transformers,
500 kVA and Smaller:
High Voltage, 34500 Volts and Below;
Low Voltage, 7970/13800Y Volts and Below**

Reprinted September 1998

Secretariat
National Electrical Manufacturers Association

Approved May 3, 1997
American National Standards Institute, Inc.

American National Standard

Approval of an American National Standard requires verification by ANSI that the requirements for due process, consensus, and other criteria for approval have been met by the standards developer.

Consensus is established when, in the judgment of the ANSI Board of Standards Review, substantial agreement has been reached by directly and materially affected interests. Substantial agreement means much more than a simple majority, but not necessarily unanimity. Consensus requires that all views and objections be considered, and that a concerted effort be made toward their resolution.

The use of American National Standards is completely voluntary; their existence does not in any respect preclude anyone, whether he has approved the standards or not, from manufacturing, marketing, purchasing, or using products, processes, or procedures not conforming to the standards.

The American National Standards Institute does not develop standards and will in no circumstances give an interpretation of any American National Standard. Moreover, no person shall have the right or authority to issue an interpretation of an American National Standard in the name of the American National Standards Institute. Requests for interpretations shall be addressed to the secretariat or sponsor whose name appears on the title page of this standard.

CAUTION NOTICE: This American National Standard may be revised or withdrawn at any time. The procedures of the American National Standards Institute require that action be taken to reaffirm, revise, or withdraw this standard no later than five years from the date of approval. Purchasers of American National Standards may receive current information on all standards by calling or writing the American National Standards Institute.

Published by

National Electrical Manufacturers Association
1300 N. 17th Street, Rosslyn, Virginia 22209

Copyright © 1998 National Electrical Manufacturers Association

All rights reserved.

No part of this publication may be reproduced in any form, in an electronic retrieval system or otherwise, without prior written permission of the publisher.

Printed in the United States of America

CONTENTS

Section	Page
1 Foreword.....	iii
1 Scope.....	1
2 Referenced and related publications.....	1
2.1 Referenced American National Standards.....	1
2.2 Related publications.....	2
3 Ratings.....	2
3.1 Kilovolt-ampere ratings.....	2
3.2 Voltage ratings and tap ratings.....	2
4 Basic lighting impulse insulation levels and dielectric test levels.....	5
5 Tests.....	5
5.1 General.....	5
5.2 Dielectric tests.....	5
6 Construction.....	6
6.1 Bushings and terminals.....	8
6.1.1 Bushings.....	8
6.1.2 Terminals.....	8
6.1.3 Neutral termination.....	21
6.1.4 Terminal boards.....	21
6.2 Accessory equipment.....	21
6.2.1 Tap changer.....	21
6.2.2 Series-multiple connections.....	24
6.2.3 Liquid-level marking.....	24
6.2.4 Lifting lugs.....	24
6.2.5 Relief of excessive pressure.....	24
6.2.6 Enclosure integrity.....	26
6.3 Polarity, terminal markings, and angular displacement.....	26
6.3.1 Polarity.....	26
6.3.2 Angular displacement.....	26
6.3.3 Terminal markings.....	26
6.3.4 Instruction nameplate.....	27
6.3.5 Kilovolt-ampere rating on tank.....	27
6.3.6 Connections for shipment by the manufacturer.....	27
6.4 Oil preservation.....	37
6.5 Tanks.....	37
6.5.1 Covers and handholes.....	37
6.5.2 Support lugs.....	37
6.5.3 Tank finish.....	37
6.5.4 Tank grounding provisions.....	38
7 Storage and installation.....	38
7.1 Storage.....	38
7.2 Installation.....	38

ANSI C57.12.20-1997

8	Design tests for fault current capability of overhead distribution transformer enclosures.....	38
8.1	Objective	38
8.2	Definitions	39
8.2.1	Enclosures	39
8.2.2	Internal fusible element.....	39
8.2.3	Back-up protection.....	39
8.2.4	A test.....	39
8.2.5	A fault.....	39
8.3	General requirements	39
8.4	Tests	40
8.5	Test number 1 – an arcing fault in an enclosure.....	40
8.5.1	First fault.....	40
8.5.2	Second fault.....	40
8.6	Test number 2 – for enclosures with internal fusible elements.....	40
8.6.1	"A" fault	40
8.6.2	"B" fault	30
8.7	Test results	41
	Annex A.....	A-1

Foreword (This Foreword is not part of American National Standard C57.12.20-1997)

In 1938 the EEI-NEMA (Edison Electric Institute-National Electrical Manufacturers Association) Joint Committee on Standards for Distribution Transformers was organized to develop standards for the various types of distribution transformers. For 23 years the continuous work of this Joint Committee was evidenced by a series of reports published jointly by the Edison Electric Institute (EEI) and the National Electrical Manufacturers Association (NEMA). The last report on overhead-type distribution transformers was the Seventh Report published in April 1961. The Joint Committee's last two reports on overhead-type distribution transformers were approved as American National Standards, the Seventh Report being reissued as American National Standard C57.12.20-1962.

To avoid further duplication of effort and to simplify future revisions, the EEI-NEMA Joint Committee on Standards for Distribution Transformers was dissolved and replaced by new subcommittees of Accredited Standards Committee on Transformers, Regulators, and Reactors, C57. The work on standards for overhead-type distribution transformers was taken over by the Subcommittee on Distribution Transformers, Overhead and Pad-Mounted, C57.12.2.

This standard was prepared by IEEE Subcommittee C57.12.2 on behalf of C57 and is a revision of ANSI C57.12.20-1988, Requirements for Overhead-Type Distribution Transformers, 500 kVA and Smaller: High-Voltage, 67000 Volts and Below; Low-Voltage, 15000 Volts and Below. The previous edition was dated 1981. The 1981 revision included detailed requirements on relief of excessive pressure. The 1988 revision recognized the step-down and series-multiple designs in distribution transformers, and omitted the platform- or station-type transformer. In recognition of the dramatic reduction in catastrophic failures of overhead transformers since the formulation of NEMA Standards Proposal Number TR-P7-1975, the 1988 revision included in Section 8 this updated NEMA proposal that is now designated 2.02 of NEMA Standards Publication for Transformers, Regulators, and Reactors, NEMA TR 1-1980. The general industry consensus is that transformers that are built in conformance with this standard and that have adequate overcurrent protection, and recognizing the limitations included therein, will provide for enclosures with reasonable withstand capability.

Suggestions for improvement of this standard will be welcome. They should be sent to the National Electrical Manufacturers Association, 1300 North 17th Street, Suite 1847, Rosslyn, Virginia, 22209

This standard was processed and approved for submittal to ANSI by Accredited Standards Committee on Transformers, Regulators, and Reactors, C57. Committee approval of the standard does not necessarily imply that all committee members voted for its approval.

At the time it approved this standard, the C57 Committee had the following members:

Chairman: Paul Orehek
Vice Chairman: J. D. Borst
Secretary: John A. Gauthier

<i>Organization Represented</i>	<i>Name of Representative</i>
U.S. Dept. of Energy, Western Area Power Administration	Kenneth C. Wolohon
Dept of Navy Civil Engineer Corps, Civil Engineer Corps	C. M. Mandeville
Dept of Interior, Bureau of Reclamation	D. J. Mulligan
Dept of Agriculture, REA	J. Bohlk
Tennessee Valley Authority	F. Lewis
<i>Electric Light & Power Delegation</i> Public Service Electric & Gas Co.	P.E. Orehek (Chairman of Delegation)

ANSI C57.12.20-1997

Consolidated Edison Co. of NY, Inc.
 Niagara Mohawk Power Corp.
 T.U. Electric
 Edison Electric Institute
 Southern California Edison Co.
 Tampa Electric Co.

E. A. Bertolini
 T. Diamantis
 K. S. Hanus
 Gary Miller (Alternate)
 G. A. Paiva
 J. Sullivan

*Institute of Electrical & Electronic Engineers
 Delegation*

ABB Power T& D Company
 Penn Power
 Beckwith Electric Company
 Baltimore Gas & Electric Company
 Southern Company Services Inc.
 PEMCO Corporation
 Commonwealth Edison

J. D. Borst (Chairman of Delegation)
 W. B. Binder
 J. H. Harlow
 J. W. Matthews
 B. Patel
 H. Smith (Alternate)
 T. P. Traub

*National Electrical Manufacturers
 Association Delegation*

General Electric Company
 Cooper Power Systems
 R. E. Uptegraff Manufacturing Co.
 Cooper Power Systems
 Square D Company
 ABB Power T&D Company
 ABB Power T&D Company
 North American Transformer, Inc.
 Hevi-Duty Electric
 Underwriters Laboratories, Inc.

G. Coulter (Chairman of Delegation)
 M. Austin
 S. Endersbe
 A. Ghafourian (Alternate)
 P.J. Hopkinson
 K. R. Linsley
 R. Plaster (Alternate)
 H. Robin
 J. Sims (Alternate)
 M. Schacker

Members of Working Group C57.12.20

Glenn Andersen
 Rick Anderson
 Jerry Bishop
 Charles V. Brown
 Ned Brush
 Charles Bryant
 William E. Carter
 Tom Diamantis
 Kevin Edwards
 Ali Ghafourian
 Ken Hanus
 David Helriegel

Richard Hollingsworth
 John Hunt
 Ron Jordan
 Brian Klaponski
 John Lazar
 James Long
 Mark Loveless
 Dave Lyon
 Al McGuire
 Matthew Mingoia
 Sam Michael
 Norvin Mohesky
 Gerry Paiva

Jesse Patton
 Tom Pekarek
 Clyde Pearson
 Jerry Rowe
 Dave Rolling
 Robert Scheu
 Jeff Schneider
 Ed Smith
 Jerry Smith
 Ron Stahara
 Al Traut
 Miguel Valbuena
 Dorman Whitley
 Alan Wilks

AMERICAN NATIONAL STANDARD**ANSI C57.12.20-1997***for Transformers—*

**Standard for overhead type distribution transformers, 500 kVA and smaller:
high voltage, 34500 volts and below; low voltage, 7970/13800Y volts and below**

1 Scope

1.1 This standard is intended for use as a basis for determining the performance, interchangeability, and safety of the equipment covered, and to assist in the proper selection of such equipment.

1.2 This standard covers certain electrical, dimensional, and mechanical characteristics and takes into consideration certain safety features of single- and three-phase, 60-Hz, mineral-oil-immersed, self-cooled, overhead-type distribution transformers 500 kVA and smaller, with high voltages 34500 volts and below and low voltages 7970/13800Y volts and below. Such transformers may include one or more of the following features:

- (1) High-voltage, overcurrent protection
- (2) High-voltage, overvoltage protection
- (3) Low-voltage, overcurrent protection
- (4) Low-voltage, overvoltage protection

NOTE: For polychlorinated-biphenyl (PCB) contamination in transformers, refer to the latest federal regulations.

2 Referenced and related publications**2.1 Referenced American National Standards**

This standard is intended for use in conjunction with the following American National Standards. All characteristics, definitions, terminology, voltage designations, and tests, except as specified herein, shall be in accordance with these referenced American National Standards. When the following referenced standards are superseded by a revision approved by the American National Standards Institute, Inc., the latest revision shall apply.

ANSI C57.12.70, *Terminal Markings and Connections for Distribution and Power Transformers*

ANSI C135.1, *Galvanized Steel Bolts and Nuts for Overhead Line Construction*

ANSI/IEEE C37.40 and C37.40a, *Service Conditions and Definitions for High-Voltage Fuses, Distribution Enclosed Single-Pole Air Switches, Fuse Disconnecting Switches, and Accessories*

ANSI/IEEE C37.41, *Design Tests for High-Voltage Fuses, Distribution Enclosed Single-Pole Air Switches, Fuse Disconnecting Switches, and Accessories*

ANSI/IEEE C57.12.00, *General Requirements for Liquid-Immersed Distribution, Power, and Regulating Transformers*

ANSI/IEEE C57.12.80, *Terminology for Power and Distribution Transformers*

ANSI C57.12.20-1997

ANSI/IEEE C57.12.90, *Test Code for Liquid-Immersed Distribution, Power, and Regulating Transformers and Guide for Short-Circuit Testing of Distribution and Power Transformers*

ANSI/IEEE C57.91, *Guide for Loading Mineral-Oil-Immersed Overhead and Pad-Mounted Distribution Transformers Rated 500 kVA and Less with 65°C or 55°C Average Winding Rise*

2.2 Related publications

The following publications are listed for information only and are not essential for the completion of the requirements of this standard: (Latest Revision shall apply)

NEMA MG2, *Safety Standard for Construction and Guide for Selection, Installation, and Use of Electric Motors* (available from National Electrical Manufacturers Association, 1300 North 17th Street, Suite 1847, Rosslyn, Virginia 22209).

NEMA TR 1, *Transformers, Regulators, and Reactors* (available from National Electrical Manufacturers Association, 1300 North 17th Street, Suite 1847, Rosslyn, Virginia 22209).

MIL-STD-209C, *Swinging Eyes and Attachments for Lifting and Tying Down Military Equipment*. (available from Commanding Officer, Naval Publications and Forms, 5801 Tabor Avenue, Philadelphia, PA 19120).

3 Ratings

3.1 Kilovolt-ampere ratings

Kilovolt-ampere ratings are continuous and are based on not exceeding either a 65°C average winding temperature rise or an 80°C hot-spot temperature rise. The temperature rise of the insulating oil shall not exceed 65°C when measured near the top of the tank. Kilovolt-ampere ratings for single-phase and three-phase transformers shall be as shown in Table 1. These ratings are based on the usual temperature and altitude service conditions specified in ANSI/IEEE C57.12.00.

3.2 Voltage ratings and tap ratings

3.2.1 Voltage ratings for single-phase and three-phase transformers shall be in accordance with Tables 2, 3, and 4. No taps are to be provided unless otherwise specified in accordance with 3.2.2.

3.2.2 When specified, tap ratings for single- and three-phase transformers shall be in accordance with Table 5. All tap ratings shall be at rated kilovolt-amperes, except as otherwise indicated. Voltages in Tables 2, 3, and 4 are without taps.

Table 1 – Kilovolt-ampere ratings

Single Phase	Three Phase
10	30
15	45
25	75
37-1/2	112-1/2
50	150
75	225
100	300
167	500
250	
333	
500	

Table 2 – Ratings for single-phase transformers (single ratio)

Transformer High Voltage Rating	Minimum kVA Rating for Low Voltage Rating of:					
	BIL (kV)	120/240 (1)	277 or 240/480 (1)	2400 or 4800	7200 or 7620 or 7970	Table 7 Figure Reference
2400/4160Y	60	10	10	---	---	9
4800/8320Y	75	10	10	---	---	9
7200/12470Y	95	10	10	50	---	10
12 470GrdY/7200	95	10	10	50	---	6, 7
7620/13 200Y	95	10	10	50	---	10
13 200GrdY/7620	95	10	10	50	---	6, 7
12 000	95	10	10	50	50	10, 11
13 200/22 860Y (2)	125	10	10	50	50	10, 11
13 200	95	10	10	50	50	10, 11
13 800GrdY/7970	95	10	10	50	---	6, 7
13 800/23 900Y (2)	125	10	10	50	50	10, 11
13 800	95	10	10	50	50	10, 11
14 400/24 940Y (2)	125	10	10	50	50	10, 11
24 940GrdY/14 400 (2)	125	10	10	50	50	6, 7, 8
16 340	95	10	10	50	50	10, 11
34 500GrdY/19 920 (3) (4)	150	10	10	50	50	6, 7, 8
34 500	200	25	25	50	50	10, 11

- (1) Low-voltage rating of 120/240 volts or 240/480 volts is suitable for series, multiple, or three-wire service
- (2) Suitable for wye-connection on systems where ground connections permit the use of 18-kV arresters
- (3) Suitable for wye-connection on systems where ground connections permit the use of 27-kV arresters
- (4) 125 KV BIL may be used based on user vendor agreement

ANSI C57.12.20-1997

Table 3 – Ratings for single-phase transformers (series – multiple)

Transformer High Voltage Rating	Minimum kVA Rating for Low Voltage Rating of:				
	Minimum BIL (kV) (1)	120/240 (2)	277 or 240/480 (2)	2400 or 4800	Table 8 Figure Reference
2400/4160Y x 7200/12 470Y	60 x 95	10	10	50	10
4160GrdY/2400 x 12 470GrdY/7200	60 x 95	10	10	---	6, 7
2400/4160Y x 7620/13 200Y	60 x 95	10	10	50	10
4160GrdY/2400 x 13 200GrdY/7620	60 x 95	10	10	---	6, 7
4800/8320Y x 7200/12 470Y	75 x 95	10	10	50	10
8320GrdY/4800 x 12 470GrdY/7200	75 x 95	10	10	---	6, 7
4800/8320Y x 7620/13 200Y	75 x 95	10	10	50	10
8320GrdY/4800 x 13 200GrdY/7620	75 x 95	10	10	---	6, 7
7200/12 470Y x 14 400/24 940Y	95 x 125	10	10	50	10
12 470GrdY/7200 x 24 940GrdY/14 400	95 x 125	10	10	---	6, 7
7620/13 200Y x 14 400/24 940Y	95 x 125	10	10	50	10
13 200GrdY/7620 x 24 940GrdY/14 400	95 x 125	10	10	---	6, 7

(1) Arrester coordination may require higher BIL on Multiple connection than indicated to achieve a minimum protective level of 20%.

(2) Low-voltage rating of 120/240 volts or 240/480 volts is suitable for series, multiple, or three-wire service

Table 4 – Ratings for three-phase transformers

Transformer High Voltage Rating (1)	Minimum BIL (kV)	Minimum kVA Rating for Low Voltage Rating of:					Table 1: Figure Reference
		208Y/120	240 or 480	240 x 480	480Y/277	2400 or 4160Y/2400 or 4800 or 8320Y/4800	
2400	45	30	30	30	30	---	12
4160Y/2400	60	30	---	---	30	---	12
4160Y	60	30	30	30	---	---	12
4160	60	30	30	30	30	---	12
4800	60	30	30	30	30	---	12
8320Y/4800	75	30	---	---	30	---	12
8320Y	75	---	30	30	---	---	12
7200	75	30	30	30	30	150	13
12 000	95	30	30	30	30	150	13
12 470Y/7200	95	30	---	---	30	---	13
12 470Y	95	---	30	30	---	---	13
13 200Y/7620	95	30	---	---	30	---	13
13 200Y	95	---	30	30	---	---	13
13 200	95	30	---	30	30	150	13
13 800	95	30	30	30	30	150	13
13 800GrdY/7970	95	30	---	---	30	---	13
24 940GrdY/14 400	125	30	---	---	30	---	13
34 500GrdY/19 920	150	30	---	---	30	---	13

(1) All transformers are delta-connected unless otherwise specified

ANSI C57.12.20-1997

6 Construction

For the purpose of this standard, two principal reference locations have been established, as shown in Figures 1 and 2. The first of these is a horizontal plane that passes through the top of the bolt slot in the upper support lug. For the second, the transformer cover has been divided into four segments. The segments are numbered in a clockwise direction with the centerline of segment 1 on the centerline of the low-voltage bushings, as shown in Figures 1 and 2.

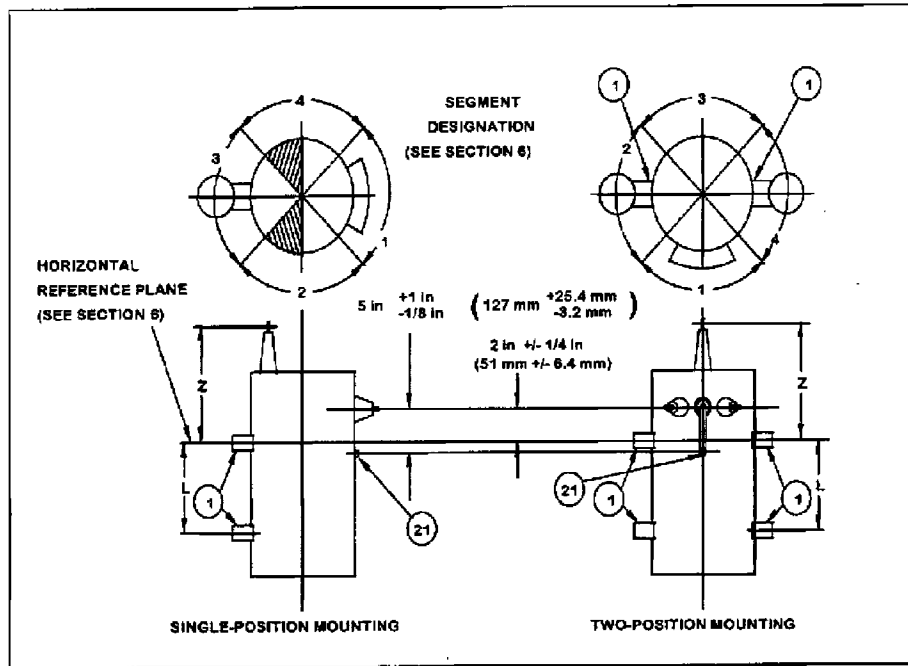

High Voltage Rating (kV)	kVA	Support Lug Type	L		Z ₍₁₎	
			Inches	mm	Inches	mm
7.62/13.2Y and below, 13.8GrdY/7.97 and below, and 12	10 - 50	A	11-1/4	286	15 +/- 3	381 +/- 76
	75 - 167	B	23-1/4	591	15 +/- 3	381 +/- 76
	250 - 333	C	24	610	15 +/- 3	381 +/- 76
	500	C	36	914	15 +/- 3	381 +/- 76
13.2/22.86Y to 14.4/24.94Y, 24.94GrdY/14.4, 34.5 GrdY/19.92, and 16.34	10 - 50	A	11-1/4	286	16-1/2 +/- 3	419 +/- 76
	75 - 167	B	23-1/4	591	16-1/2 +/- 3	419 +/- 76
	250 - 333	C	24	610	19-1/2 +/- 3	495 +/- 76
	500	C	36	914	19-1/2 +/- 3	495 +/- 76

(1) Z dimension applies only to high-voltage cover bushing transformers.

Figure 1 – Segment designations and interchangeability dimensions for single phase transformers

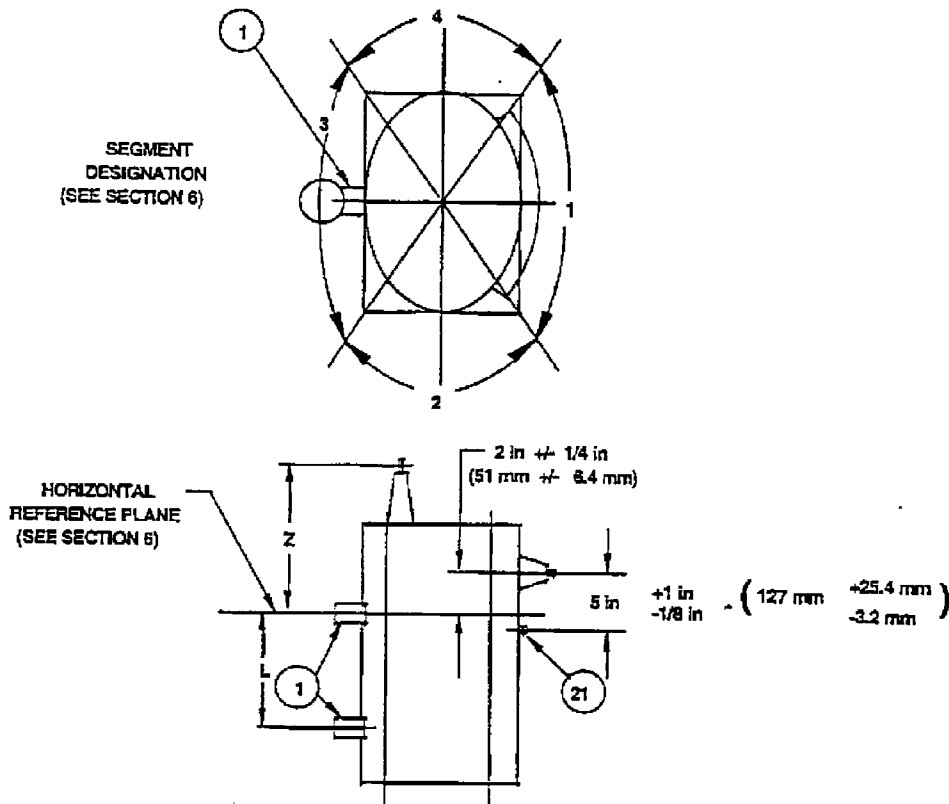

High Voltage Rating (kV)	kVA	Support Lug Type	L		Z (1)	
			Inches	mm	Inches	mm
13 800GrdY/7970, 13 800 and below	15 - 30	A	23-1/4	591	15 +/- 3	381 +/- 76
	45 - 75	B	23-1/4	591	15 +/- 3	381 +/- 76
	112-1/2 - 300	C	36 (2)	914	15 +/- 3	381 +/- 76
19 920 and Below	15 - 30	A	23-1/4	591	16 1/2 +/- 3	419 +/- 76
	45 - 75	B	23-1/4	591	16 1/2 +/- 3	419 +/- 76
	112-1/2 - 300	C	36 (2)	914	19 1/2 +/- 3	495 +/- 76

(1) Z dimension applies only to high-voltage cover bushing transformers.

(2) 24-inch (610 mm) spacing may be used when tank height will not permit the 36-inch (914 mm) dimension

Figure 2 – Segment designations and interchangeability dimensions for three phase transformers

ANSI C57.12.20-1997

Table 6 – Electrical characteristics of bushings

BIL Withstand (kV)	Creepage Distance (1)		60-Hz Dry 1-Minute Withstand (kV)	60-Hz Wet 1-Minute Withstand (kV)
	Inches	Millimeters		
30	---	---	10	6
45	---	---	15	13
60	---	---	21	20
75	---	---	27	24
95	10-1/2 +/- 1/2	267 +/- 13	35	30
150	17	432	60	50
Single Phase Transformer Bushings Only				
95 (2)	16-1/2 +/- 1-1/2	419 +/- 38	35	30
125	16-1/2 +/- 1-1/2	419 +/- 38	42	36
200	26	660	80	75

(1) Creepage distances are minimum values where no tolerance is specified.

(2) For 16.34 kV rating only.

6.1 Bushings and terminals

6.1.1 Bushings

6.1.1.1 Electrical characteristics of transformer bushings shall be as listed in Table 6.

6.1.1.2 The number, location, and arrangement of bushings for single-phase and three-phase transformers shall be as shown in Tables 7, 8, 9, and 15, and Figure 3. The centerline of the high-voltage bushings shall be located within the shaded areas. The positions of high-voltage bushings for three-phase transformers need not be symmetrical. Low-voltage bushings shall be of the sidewall or cover type and shall be individually mounted.

6.1.1.3 Unless otherwise specified, the color of bushings shall match Light Gray Number 70, Munsell Notation 5BG7.0/0.4.

6.1.2 Terminals

6.1.2.1 Terminal details shall be as shown in Figure 4.

6.1.2.2 High-voltage bushings of transformers 200 kV BIL and below shall be equipped with tinned, copper-alloy solderless connectors. High-voltage terminal sizes shall be as shown in Tables 10 and 11.

6.1.2.3 Low-voltage terminal sizes shall be as shown in Tables 12 and 13.

6.1.2.4 Terminals of low-voltage windings 600 volts and below shall be arranged for vertical take-off.

6.1.2.5 External spacing between low-voltage bushing terminals shall be such as to provide the maximum clearance between live metal parts in the working area. For low-voltage ratings above 600 volts, the electrical characteristics of the bushings determine the spacing. For low-voltage ratings 600 volts and below, spacings shall be within the limits of Table 14.

Table 7 - Accessory equipment for single-phase transformers (single-ratio)

Segment Designations		Figure 6		Figure 7		Figure 8		Figure 9		Figure 10		Figure 11	
Centerline of Low-Voltage Bushings		High Voltage (kV)		High Voltage (kV)		High Voltage (kV)		High Voltage (kV)		High Voltage (kV)		High Voltage (kV)	
Item Number	Selection Reference	Accessory Equipment	10 to 50 kVA	50 to 100 kVA	100 to 167 kVA	167 to 250 kVA	250 to 500 kVA	500 to 600 kVA	600 and Below kVA	600 and Below kVA	5000 and Below kVA	5000 and Below kVA	Above 5000 kVA
1	6.5.2	Support lug - Type	X	X	X	X	X	X	X	X	X	X	X
5	6.2.3	Liquid-level marking	X	X	X	X	X	X	X	X	X	X	X
9	6.2.1	Tap Changer (when specified)	X	X	X	X	X	X	X	X	X	X	X
14	6.5.1	Handhole in cover (1)	X	X	X	X	X	X	X	X	X	X	X
16	6.2.4	Lifting Lugs	X	X	X	X	X	X	X	X	X	X	X
17	6.5.4.1	Tank grounding provision	X	X	X	X	X	X	X	X	X	X	X
19	6.5.4.2	Tank grounding connector	X	X	X	X	X	X	X	X	X	X	X
20	6.5.4.3	Low-voltage grounding connection (2)	X	X	X	X	X	X	X	X	X	X	X
21	6.5.4.4	Low-voltage grounding provision (3)	X	X	X	X	X	X	X	X	X	X	X
22	6.1.2.2	High-voltage bushing terminals	X	X	X	X	X	X	X	X	X	X	X
23	6.1.2.3	Low-voltage bushing terminals	X	X	X	X	X	X	X	X	X	X	X
24	6.1.1.2	Low-voltage bushing arrangement	X	X	X	X	X	X	X	X	X	X	X
25	6.3.4.1.1	Nameplate Location	X	X	X	X	X	X	X	X	X	X	X
28	6.3.4.1.2	Nameplate Location	X	X	X	X	X	X	X	X	X	X	X
30	6.3.4.2	Nameplate - Type (5)	X	X	X	X	X	X	X	X	X	X	X
31	6.3.5	kVA rating on tank	X	X	X	X	X	X	X	X	X	X	X
32	6.2.5.1	Pressure-relief valve (4)	X	X	X	X	X	X	X	X	X	X	X

ANSI C57.12.20-1997

(1) Supplied only on units with internal tap changers.
 (2) For 120/240 volts only.
 (3) For 240/480 volts and 277 volts.
 (4) Segment location not specified. Not required if cover design is in accordance with 6.2.5.2.
 (5) Nameplate shall show BIL for 34.5GrdV/19.92.

ANSI C57.12.20-1997

Table 8 – Accessory Equipment for Single-Phase Transformers (Series-Multiple)

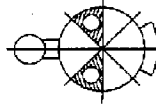
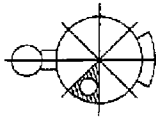
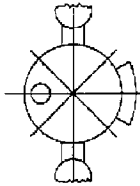
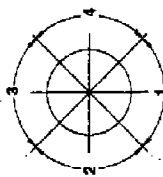

Segment Designations
Centerline of Low-Voltage
Bushings



Item Number	Selection Reference	Accessory Equipment	600 and Below				5000 and Below				
			10 to 50	75 to 100	167 to 250	500 to 5000	A to 50	B to 167	C to 250	D to 5000	
1	6.5.2	Support lug - Type	A	A	A	A	A	A	A	A	A
5	6.2.3	Liquid-level marking	X	X	X	X	X	X	X	X	X
9	6.2.1	Tap Changer (when specified)	X	X	X	X	X	X	X	X	X
14	6.5.1	Handhole in cover (1)	X	X	X	X	X	X	X	X	X
16	6.2.4	Lifting Lugs	X	X	X	X	X	X	X	X	X
17	6.5.4.1	Tank grounding provision	X	X	X	X	X	X	X	X	X
19	6.5.4.2	Tank grounding connector	X	X	X	X	X	X	X	X	X
20	6.5.4.3	Low-voltage grounding connection (2)	X	X	X	X	X	X	X	X	X
21	6.5.4.4	High-voltage grounding provision (3)	X	X	X	X	X	X	X	X	X
22	6.1.2.2	High-voltage bushing terminals	X	X	X	X	X	X	X	X	X
23	6.1.2.3	Low-voltage bushing terminals	X	X	X	X	X	X	X	X	X
24	6.1.1.2	Low-voltage bushing arrangement	X	X	X	X	X	X	X	X	X
25	6.3.4.1.1	Nameplate Location	X	X	X	X	X	X	X	X	X
28	6.3.4.1.2	Nameplate - Type	X	X	X	X	X	X	X	X	X
30	6.3.4.2	KVA rating on tank	X	X	X	X	X	X	X	X	X
31	6.3.5	Pressure-relief valve (4)	X	X	X	X	X	X	X	X	X
32	6.2.5.1	Series-Multiple Device	X	X	X	X	X	X	X	X	X
33	6.2.2	Supplied only on units with internal terminal boards.	X	X	X	X	X	X	X	X	X

(1) Supplied only on units with internal terminal boards.
 (2) For 120/240 volts only.
 (3) For 240/480 volts and 277 volts.
 (4) Segment location not specified. Not required if cover design is in accordance with 6.2.5.2.

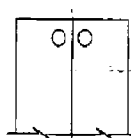
Table 9 – Number of low voltage terminals and arrangement for single-phase transformers

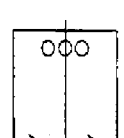
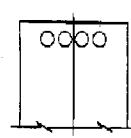
kVA Range for High Voltage Rating of 34.5 kV and Below, 14.4/24.94Y kV and Below, 34.5GrdY/19.92 kV and Below						
Low-Voltage Ratings (Volts)						
120/240	---	---	10 - 50 (1)	10 - 100 (1)	167 (1)	250 - 500
240/480	---	---	---	10 - 100	167	---
277 (2)	10 - 500	---	---	---	---	---
2400 - 4800	50 - 500	---	---	---	---	---
7200 - 7970	---	50 - 500	---	---	---	---

(1) Transformers with single high-voltage bushing. See 6.5.4.3.

(2) For 167 kVA and Below, low-voltage grounding provision on centerline below low-voltage terminals.

ANSI C57.12.20-1997

Table 10 – High-voltage terminal sizes for single-phase transformers

Size of Terminal Opening		Terminal Detail Figure	AWG Size of Conductor Terminal will Accommodate	kVA Range for High-Voltage Rating of:	
Inches	Millimeters			5 kV and Below	7.2 kV - 34.5 kV
5/16	7.9	4a	No. 8 Solid to No 2 Stranded No 6 Solid to No 4/0-19 Stranded	10 - 167	10 - 500
5/8	15.9	4a		250 - 500	---

Table 11 – High-voltage line and neutral terminal sizes for three-phase transformers

Size of Terminal Opening		Terminal Detail Figure	AWG Size of Conductor Terminal will Accommodate	kVA Range for High-Voltage Rating of:	
Inches	Millimeters			5 kV and Below	7.2 kV - 16.34 kV 34.5GrdY/19.92 kV
5/16	7.9	4a	No. 8 Solid to No 2 Stranded No 6 Solid to No 4/0-19 Stranded	30 - 225	30 - 500
5/8	15.9	4a		300 - 500	---

Table 12 - Low-voltage terminal sizes for single-phase transformers

Size of Terminal Opening Inches	Terminal Opening Millimeters	Terminal Detail Figure	AWG Size of Conductor Terminal will Accommodate	KVA Range for Low-Voltage Rating of		
				240/480	277	2400 - 4800
5/16	7.9	4a	No. 8 Solid to No. 2 Stranded	---	---	7200 - 7970
5/8	15.9	4a	No. 6 Solid to No. 4/0-19 Stranded	10 - 25	10 - 25	50 - 167
13/16	20.6	4a	No. 2 Solid to 350 kcmil 19 Stranded	37 1/2 - 100	37 1/2 - 100	250 - 500
15/16	23.8	4a	No. 1/0 Solid to 500 kcmil 37 Stranded	---	---	---
1-1/4	31.8	4a	No. 2/0 Solid to 1000 kcmil 61 Stranded	---	---	---
Spade H		4b	---	167 - 250	167 - 250	---
Spade J		4c	---	333 - 500	333 - 500	---

Table 13 - Low-voltage line and neutral terminal sizes for three-phase transformers

Size of Terminal Opening Inches	Terminal Opening Millimeters	Terminal Detail Figure	Size of Conductor Terminal will Accommodate	KVA Range for Low-Voltage Rating of:		
				208Y/120	480 Y/277	2400 and above
5/16	7.9	4a	No. 8 Solid to No. 2 Stranded	240	480	30 - 150
5/8	15.9	4a	No. 6 Solid to No. 4/0-19 Stranded	---	---	300 - 500
13/16	20.6	4a	No. 2 Solid to 350 kcmil 19 Stranded	30 - 45	30 - 75	---
15/16	23.8	4a	No. 1/0 Solid to 500 kcmil 37 Stranded	75 - 150	112-1/2 - 300	---
1-1/4	31.8	4a	No. 2/0 Solid to 1000 kcmil 61 Stranded	225	---	---
Spade H		4a	---	300	---	---
Spade J		4b	---	---	500	---
		4c	---	500	---	---

ANSI C57.12.20-1997

Table 14 - Minimum electrical clearances (low-voltage terminals - 600 volts and below)

Single Phase Rating (kVA)	Three-Phase Rating (kVA)	Minimum Clearance Between Live Metal Parts (1)		Maximum Spacing Between Center Points of Bushing Terminals	
		Inches	Millimeters	Inches	Millimeters
10 - 50	30 - 150	1-3/4 (2)	45 (2)	9	229
75 - 500	225 - 500	3 (2)	76 (2)	9	229

(1) When moveable parts of bushing terminals are in the same relative position.

(2) When tank dimensions will not permit this spacing, the spacing may be reduced by not more than 3/4 inch (19 mm).

Table 15 - Accessory equipment for three-phase transformers

Segment Designations

Centerline of Low-Voltage Bushings

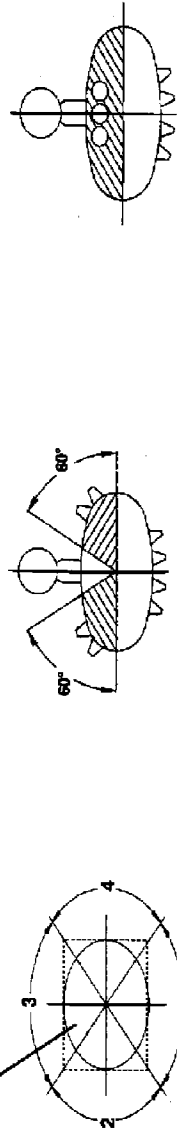

Outline Drawing		Figure 12 (1)										Figure 13 (1)													
High Voltage (kV)		4.8 and Below 6.32Y and Below										7.2 to 13.8 12.47Y to 13.2Y 13.8GrdY/7.97 24.94GrdY/14.4 34.5GrdY/19.92 5000 and Below													
Low Voltage (volts)		600 and Below										5000 and Below													
Item Number	Selection Reference	30			45 to 75			112 - 1/2 to 300			600			30			45 to 75			112 - 1/2 to 300			500		
		A	B	C	A	B	C	A	B	C	A	B	C	A	B	C	A	B	C	A	B	C			
1	6.5.2	X	X	X	X	X	X	X	X	X	X	X	X	X	X	X	X	X	X	X	X	X			
5	6.2.3	X	X	X	X	X	X	X	X	X	X	X	X	X	X	X	X	X	X	X	X	X			
9	6.2.1	X	X	X	X	X	X	X	X	X	X	X	X	X	X	X	X	X	X	X	X	X			
14	6.5.1	X	X	X	X	X	X	X	X	X	X	X	X	X	X	X	X	X	X	X	X	X			
16	6.2.4	X	X	X	X	X	X	X	X	X	X	X	X	X	X	X	X	X	X	X	X	X			
17	6.5.4.1	X	X	X	X	X	X	X	X	X	X	X	X	X	X	X	X	X	X	X	X	X			
19	6.5.4.2	X	X	X	X	X	X	X	X	X	X	X	X	X	X	X	X	X	X	X	X	X			
21	6.5.4.4	X	X	X	X	X	X	X	X	X	X	X	X	X	X	X	X	X	X	X	X	X			
22	6.1.2.2	X	X	X	X	X	X	X	X	X	X	X	X	X	X	X	X	X	X	X	X	X			
23	6.1.2.3	X	X	X	X	X	X	X	X	X	X	X	X	X	X	X	X	X	X	X	X	X			
24	6.1.1.2	X	X	X	X	X	X	X	X	X	X	X	X	X	X	X	X	X	X	X	X	X			
25	6.3.4.1.1	X	X	X	X	X	X	X	X	X	X	X	X	X	X	X	X	X	X	X	X	X			
30	6.3.4.2	A	A	A	A	A	A	A	A	A	A	A	A	A	A	A	A	A	A	A	A	A			
31	6.3.5	X	X	X	X	X	X	X	X	X	X	X	X	X	X	X	X	X	X	X	X	X			
32	6.2.5.1	X	X	X	X	X	X	X	X	X	X	X	X	X	X	X	X	X	X	X	X	X			

(1) To maintain satisfactory mechanical and electrical clearances on small kVA ratings, it is permissible to encroach upon the unshaded area.

(2) Supplied only on units with internal tap changers.

(3) Segment location not specified. Not required if cover design is in accordance with 6.2.5.2.

(4) Nameplate shall show BIL for 34.5GrdY/19.92.

Table 16 – Angular displacement

Minimum kVA Range or Ratings having Low Voltage Ratings of: (1)

Transformer High-Voltage Rating	Angular Displacement		Minimum kVA Range or Ratings having Low Voltage Ratings of: (1)					
	HV	LV	208Y/120	240 or 480	240 X 480	480Y/277	2400 or 4800	4160Y/2400
4160Y/2400 6320Y/4800			30 (a)	—	—	30 (a)	—	—
4160Y 8320Y			—	30 (c)	30 (c)	—	—	—
2400 4160 4800			30 (b)	—	—	30 (b)	—	—
13 800GrdY/7970 (2) 12 470Y/7200 (2) 13 200Y/7620 (2) 24 940GrdY/14 400 (2) 34 500GrdY/19 920 (2)			—	30 (c)	30 (c)	—	—	—
12 470Y 13 200Y			30 (d)	—	—	30 (d)	—	—
7200 12 000 13 200 13 800			—	30 (e)	30 (e)	—	—	—
			30 (f)	—	—	30 (f)	—	150 (f)
			—	30 (e)	30 (e)	—	150 (e)	—

(1) Letters in brackets (a) to (f) designate terminal designation of Figure 3.

(2) High-voltage and low-voltage neutrals internally connected by means of a removable link.

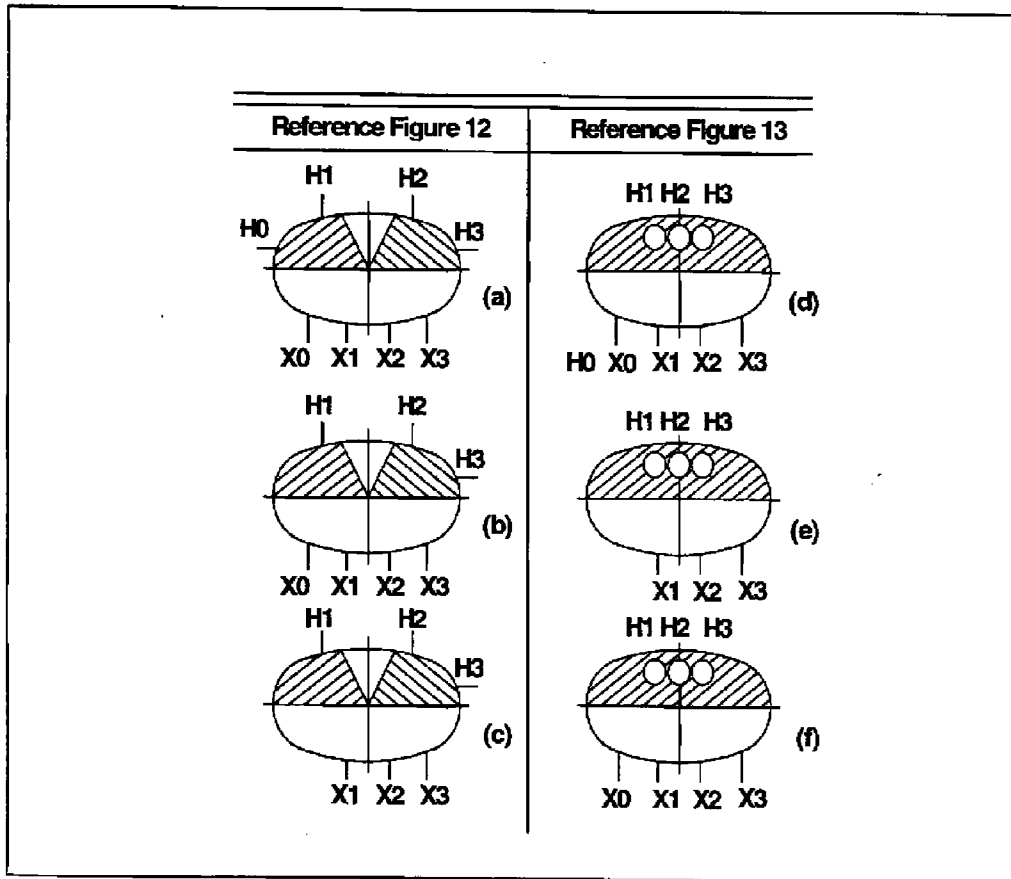

NOTE: See 6.1.1.2.

Figure 3 – Number of terminals, descriptions, and arrangement for three phase transformers

ANSI C57.12.20-1997

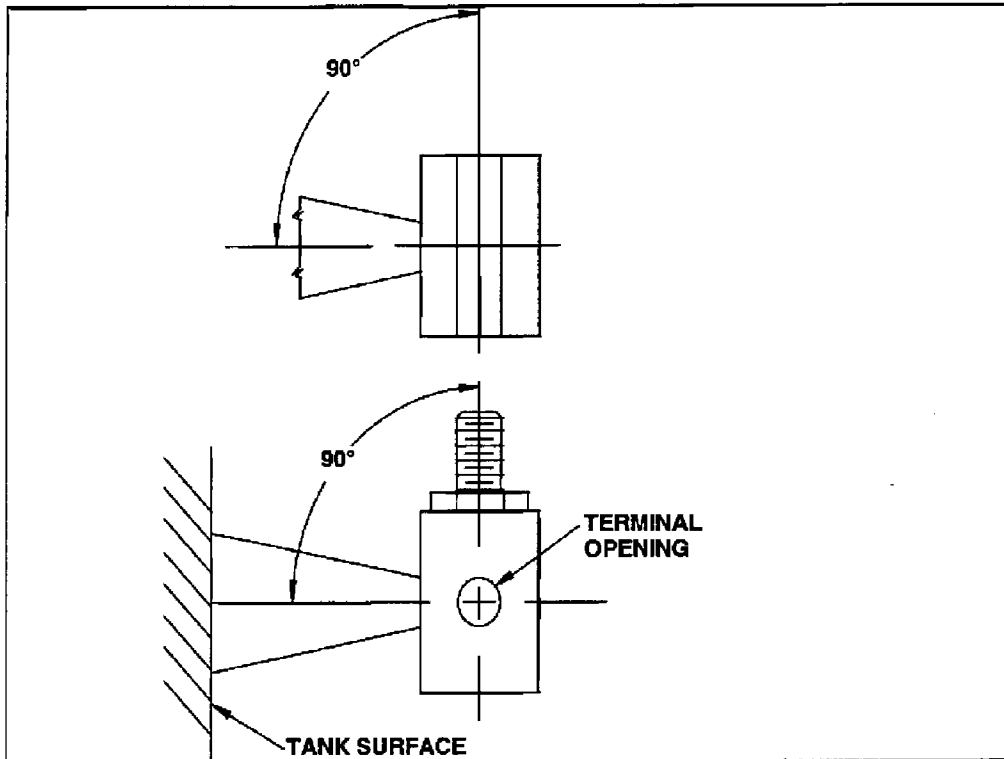

NOTES:

- (1) Threaded parts of connector shall be removable without removing bushings.
- (2) Connector Clamping Bolts shall be 3/8, 1/2, 5/8, or 3/4 NC threads, class 2 fit.
- (3) One or two connector clamping bolts may be used, but U-bolts or J-bolts shall not be used.
- (4) Terminal of low-voltage windings 600 volts and below shall be arranged for vertical takeoff.
- (5) Terminals are to be tin plated and aluminum conductors are to be properly prepared.

Figure 4a – Terminal details

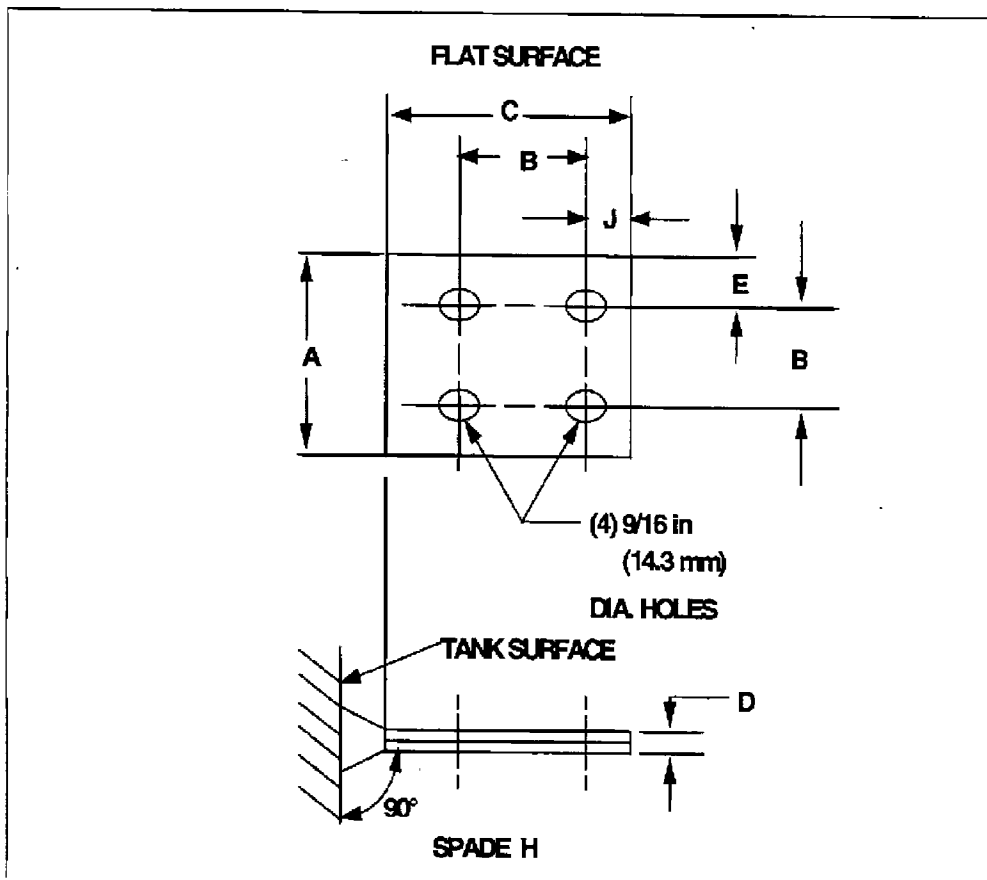

Dimension (1)	Inches	Millimeters
A	3 - 1/2	88.9
B	1 - 3/4	44.5
C	3 - 3/8 (min)	85.7 (min)
D	1/4 (min)	6.4 (min)
E	7/8	22.2
J	5/8	15.9

(1) All dimensions are nominal except as noted.

NOTE: Corners and edges may be rounded

Figure 4b – Spade H – Terminal details

ANSI C57.12.20-1997

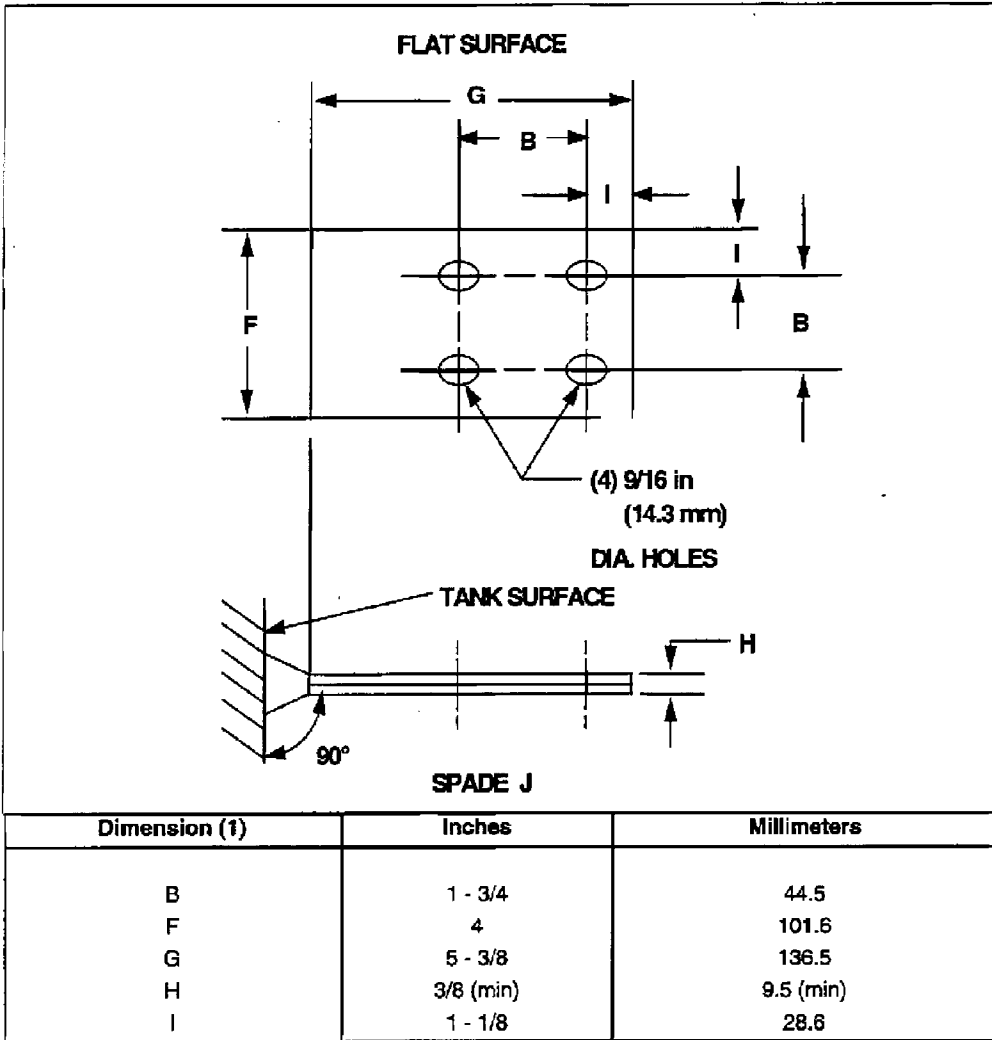

(1) All dimensions are nominal except as noted.

NOTE: Corners and edges may be rounded

Figure 4c – Spade J – Terminal details

6.1.3 Neutral termination

6.1.3.1 On single-phase transformers having one high-voltage bushing, the H_2 end of the winding shall be securely connected internally to the grounded clamping structure or the tank. This connection shall be independent of all other electrical connections.

6.1.3.2 On all three-phase transformers, a fully insulated low-voltage neutral bushing, X_n , shall be provided when the low-voltage windings are wye-connected.

6.1.3.3 On three-phase transformers, a fully insulated high-voltage neutral bushing, H_n , and a fully insulated low-voltage neutral bushing X_n , shall be provided where wye-connected, high-voltage windings are rated 8.32Y kV and below. The low-voltage windings are rated 208Y/120 volts or 480Y/277 volts. The high-voltage and low-voltage neutrals shall be connected internally by a link that is accessible and capable of reconnection.

6.1.3.4 On three-phase transformers, a common fully insulated low-voltage type neutral bushing $H_n X_n$, shall be provided where wye-connected high-voltage windings are rated above 8.32Y kV and low-voltage windings are rated 208Y/120 or 480Y/277 volts. The high-voltage and low-voltage neutrals shall be connected internally by a link that is accessible and capable of reconnection.

6.1.4 Terminal boards

On single-phase transformers with low-voltage ratings of 120/240 volts or 240/480 volts, the internal connections to the low-voltage bushings on sizes 25 kVA and smaller shall, and on sizes 37-1/2 kVA to 100 kVA inclusive may, be arranged to serve in lieu of a low-voltage terminal board. These connections shall be in conformance with and arranged as shown in Figure 5.

6.2 Accessory equipment

Accessory equipment listed in Tables 7, 8, and 15 shall be provided and located as shown in Figures 6-13.

6.2.1 Tap changer

(See item 9 in Tables 7 and 15.) Tap changers for deenergized operation shall be provided on tapped transformers. Each tap-changer position and the tap voltage or percentage associated with it shall be clearly identifiable by reference to nameplate information. All positions of the tap changer shall be operative positions. Transformers may have either an internal tap changer or an externally operated tap changer unless one or the other is specified.

The internal tap changer shall have the operating handle inside the tank above the oil level. The tap changer shall rotate in a clockwise direction from a high tap voltage to a lower tap voltage in the high-voltage winding. The tap changer shall be provided with mechanical stops to identify the highest and lowest tap positions.

ANSI C57.12.20-1997

Description of Connection

Additive Polarity (1)

Subtractive Polarity (2)

Three low-voltage external terminals suitable for series, multiple, or three-wire operation
120/240 volts
240/480 volts

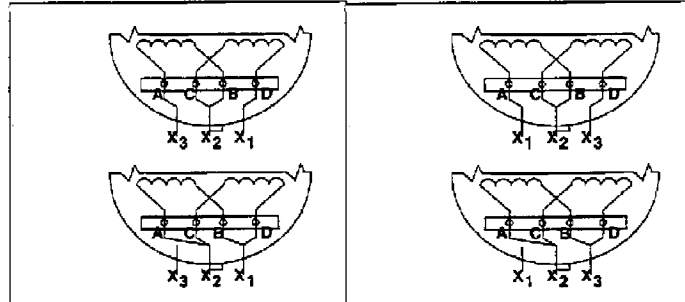

Four low-voltage external terminals suitable for series, multiple, or three-wire operation (3)
120/240 volts
240/480 volts

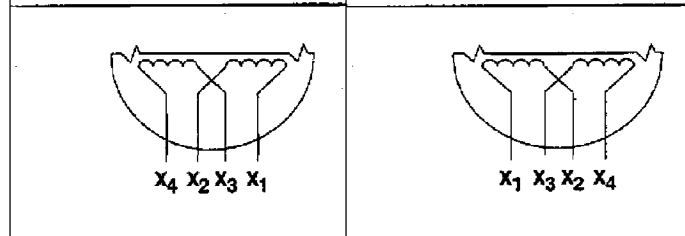

Single low-voltage rating
277 volts
2400 volts
4800 volts
7200 volts
7620 volts
7970 volts

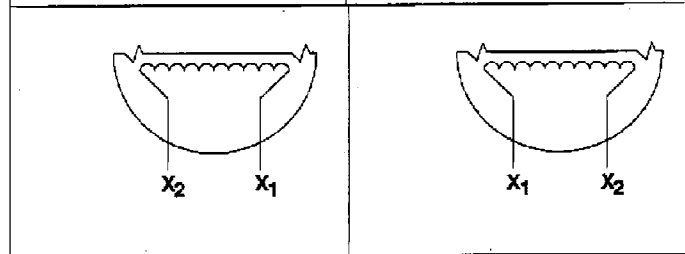

(1) Polarity is additive for transformers 200 kVA and smaller having high-voltage windings 8660 volts and below. See 6.3.1.

(2) Polarity is subtractive for transformers 200 kVA and smaller having high-voltage windings above 8660 volts and for all transformers larger than 200 kVA. See 6.3.1.

(3) Connect X2 to X3 externally for series operation. Connect X2 to X4 and X3 to X1 externally for multiple operation.

NOTE: The H1 terminal for either additive or subtractive polarity is located on the left-hand side when facing the low-voltage terminals.

Figure 5 – Connections and polarity

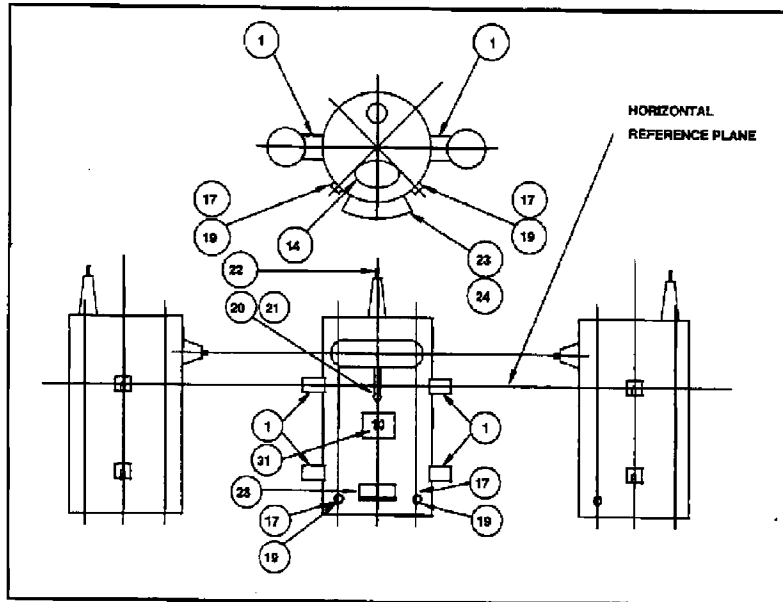

Item Number	Section Reference	Accessory Equipment	kVA 10 - 50
1	6.5.2	Support lug - Type	A
5	6.2.3	Liquid-level marking	X
9	6.2.1	Tap Changer (when specified)	X
14	6.5.1	Handhole in cover (1)	X
16	6.2.4	Lifting Lugs	X
17	6.5.4.1	Tank grounding provision	X
19	6.5.4.2	Tank grounding connector	X
20	6.5.4.3	Low-voltage grounding connection (2)	X
21	6.5.4.4	Low-voltage grounding provision (3)	X
22	6.1.2.2	High-voltage bushing terminals	X
23	6.1.2.3	Low-voltage bushing terminals	X
24	6.1.1.2	Low-voltage bushing arrangement	X
28	6.3.4.1.2	Nameplate Location	X
30	6.3.4.2	Nameplate Type	A
31	6.3.5	kVA rating on tank	X
32	6.2.5.1	Pressure-relief valve (4)	X
33	6.2.2	Series-multiple device (when specified)	X

(1) Supplied only on units with internal tap changers or series-multiple terminal boards.

(2) For 120/240 volts only.

(3) For 240/480 volts and 277 volts.

(4) Segment location not specified. Not required if cover design is in accordance with 6.2.5.2.

High-Voltage (kV)	12.47GrdY/7.2	4.16GrdY/2.40 x 12.47GrdY/7.20
	13.2GrdY/7.62	4.16GrdY/2.40 x 13.20GrdY/7.62
	13.8GrdY/7.97	8.32GrdY/4.80 x 12.47GrdY/7.20
	24.94GrdY/14.4	8.32GrdY/4.80 x 13.20GrdY/7.62
	34.5GrdY/19.92	12.47GrdY/7.20 x 24.94GrdY/14.40
Low-Voltage (volts)	600 and Below	13.20GrdY/7.62 x 24.94GrdY/14.40

Figure 6 – Single phase 10 – 50 kVA for pole mounting (two-position) single high-voltage cover bushings

ANSI C57.12.20-1997

The handle of the externally operated tap changer shall be brought out through the side of the tank in or near segment 3, as shown in Tables 7 and 15. It shall be designed to prevent accidental operation by requiring a preliminary step before the tap setting can be changed. Position number or letters corresponding to the nameplate shall be clearly identifiable near the handle. There shall be located on or adjacent to the operating mechanism a written caution statement to deenergize the transformer before operating.

6.2.2 Series-multiple connections

(See item 33 in Table 8.) The series-multiple voltage-changing device may be an internally mounted terminal board or externally operated switch, unless one or the other is specified. Either device is for deenergized operation.

Internal terminal boards with movable links shall have all studs identified on the board, and the nameplate shall show the connections to be made for each voltage.

The handle of the externally operated switch shall be brought out through the side of the tank in or near segment 3, as shown in Table 8. It shall be designed to indicate voltage position and to prevent accidental operation by requiring a preliminary step before the voltage setting can be changed. Actual voltages or position numbers corresponding to the nameplate shall be clearly identifiable near the handle. There shall be located on or adjacent to the operating mechanism a written caution statement to deenergize the transformer before operating.

6.2.3 Liquid-level marking

(See item 5 in Tables 7, 8, and 15.) A suitable marking inside the tank shall indicate the correct oil level at 25°C.

6.2.4 Lifting lugs

(See item 16 in Tables 7, 8, and 15.) The lifting lugs shall be permanently attached to and arranged on the tank to provide a balanced lift in a vertical direction for the completely assembled transformer and shall be designed to provide a safety factor of five.¹ The safety factor of five is the ratio of the ultimate stress to the working stress of the material used. The working stress is the maximum combined stress developed in the lifting lugs by the static load of the completely assembled transformer.²

6.2.5 Relief of excessive pressure

A means as specified in 6.2.5.1 or 6.2.5.2 shall be provided to relieve pressure in excess of pressure that results from normal operation. This excess pressure may build up slowly due to overloads, high ambient temperatures, or external secondary faults, or internal incipient faults in the low-voltage winding. This excess pressure should result in an emission of only a negligible amount of oil.

¹ This value is taken from 1.3, Lifting Means, in NEMA MG2-1983, Safety Standard for Construction and Guide of Selection, Installation, and Use of Electric Motors (available from National Electrical Manufacturers Association, 2101 L Street, NW, Washington, DC 20037).

² This value is taken from MIL-STD-209C, Swinging Eyes and Attachments for Lifting and Tying Down Military Equipment; (available from Commanding Officer, Naval Publications and Forms, 5801 Tabor Avenue, Philadelphia, PA 19120).

6.2.5.1 (See item 32, Tables 7, 8, and 15.) A replaceable valve shall be located on the tank above the 140°C top oil level, by the manufacturer's calculation, and so located as not to interfere with use of support lugs, lifting lugs, operating handles of switches and circuit breakers, or sidewall bushings.

The inlet port shall be 1/4-inch (6.4-mm) or larger NPT (or NC thread with gasket), sized for specified minimum flow rate. Exposed parts shall be of weather- and corrosion-resistant materials. Gaskets and O-rings shall withstand oil vapor at 105°C continuously and under operating conditions as described in ANSI/IEEE C57.91, without seizing or deteriorating, for the life of the transformer.

The valve shall have a pull ring for manually reducing pressure to atmospheric level using a standard hookstick, and shall be capable of withstanding a static pull force of 25 pounds (11.34 kg) for one minute without permanent deformation. The valve shall withstand for one minute a static force of 100 pounds (45.36 kg) applied normal to its longitudinal axis at the outermost extremity of the body. When specified, the venting port on the outward side of the valve-head seat shall be protected to prevent entry of dust, moisture, and insects before and after the valve has operated, or a weather-cap type indicator shall be provided that will remain attached to the valve and provide positive indication to an observer that the valve has operated.

Venting and sealing characteristics shall be as follows:

- (1) Venting pressure 10 psig (69 kPa) \pm 2 psig (13.8 kPa)
- (2) Sealing pressure 6 psig (41.4 kPa) minimum
- (3) Zero leakage from reseal pressure to minus 8 psig (-55.2 kPa)
- (4) Flow at 15 psig (103.5 kPa) 35 SCFM (9.91 x 10⁵ SCCM) minimum, where SCFM is the flow in standard cubic feet per minute and SCCM is the flow in standard cubic centimeters per minute, corrected for air pressure of 14.7 psi (101.43 kPa) and air temperature of 21.1°C.

6.2.5.2 A cover assembly designed to relieve excess pressure in the transformer tank shall remain effectively sealed for overloads and external secondary short circuits of the magnitude and duration allowed by industry standards and loading guides. The assembly shall relieve pressure at a minimum of 8 psig (55.2 kPa) if designed to reseal, or at a minimum of 20 psig (138 kPa) if designed for pressure relief without resealing. Such operation shall occur before other components of the tank are ruptured or displaced, and the cover shall remain in position. Manual means of venting the tank before removal of the cover shall be provided. The flow rate shall be at least equal to that of the pressure-relief device specified in 6.2.5.1.

ANSI C57.12.20-1997

6.2.6 Enclosure integrity**6.2.6.1 Static pressure³**

The completely assembled transformer enclosure shall be of sufficient strength to withstand an internal pressure of 7 psig without permanent distortion to the enclosure. The enclosure shall also be of sufficient strength to withstand an internal pressure of 20 psig without rupturing or displacing components (excluding the cover gasket and gasket oil leaks) of the transformer.

6.2.6.2 Dynamic pressure

The completely assembled transformer enclosure shall be capable of passing the fault current tests as defined in Section 8.

6.3 Polarity, terminal markings, and angular displacement**6.3.1 Polarity**

Polarity shall be additive for all single-phase transformers in sizes 200 kVA and smaller having high-voltage windings 8660 volts and below. Polarity shall be subtractive for all other single-phase transformers.

6.3.2 Angular displacement

The angular displacement between windings of three-phase transformers with delta-delta or wye-wye connections shall be 0 degrees. The angular displacement between windings of three-phase transformers with wye-delta or delta-wye connections shall be 30 degrees. Angular displacement between voltages on three-phase transformers shall be in accordance with Table 16.

6.3.3 Terminal markings

6.3.3.1 External terminal designations shall be as defined by ANSI C57.12.70, although physical terminal markings on tank or cover are not required. The low-voltage terminal designations are shown in Figure 5 for single-phase transformers and in Figure 3 for three-phase transformers.

6.3.3.2 Internal leads on single-phase transformers shall be individually identified with the letters A, C, B, and D, as shown in Figure 5, unless a lead support or other means is provided to locate such leads definitely with respect to each other. Where lead supports are used, the leads at the top or terminal side of the lead support shall be in the order A, C, B, D, reading from left to right, facing the low-voltage side. Where lead supports are not used or when the lead support does not fix the leads in the order A, C, B, D, the lead terminals shall be such as to ensure that, for multiple connection, lead A is connected only to lead C and lead B only to lead D.

³ Static does not mean constant, but implies the absence of instantaneous, impact-type pressure change forces.

6.3.3.3 All practical interchangeability, in regard to connections to external terminals, is desirable. Emphasis should be given to interchangeability of the low-voltage connections. For this purpose, the top of the bolt slot in the upper support lug establishes the horizontal reference plane. The departure from complete interchangeability shall not exceed the tolerances specified in Figures 1 and 2.

6.3.3.4 The identification of low-voltage internal and external connections shall be shown on the nameplate and shall conform to Figure 5 for single-phase transformers and Figure 3 for three-phase transformers.

6.3.4 Instruction nameplate

The instruction nameplate shall be located as shown in Figures 6 through 13.

6.3.4.1 Location

6.3.4.1.1 The instruction nameplate for single-position mounting (see item 25 in Tables 7, 8, and 15) shall be on the dividing line between segments 2 and 3, with a tolerance of ± 45 degrees, and shall be located near the bottom of the tank.

6.3.4.1.2 The instruction nameplate for two-position mounting for single-phase transformers only (see item 28 in Tables 7 and 8) shall be on the dividing line between segments 1 and 2, with a tolerance of ± 45 degrees, and shall be located near the bottom of the tank.

6.3.4.2 Type

Instruction nameplates shall contain the information specified in ANSI/IEEE C57.12.00 (see item 30 in Tables 7, 8, and 15) except that the BIL rating shall be shown for all single-phase ratings above 16 340 volts. The instruction nameplate shall be in accordance with nameplate A as described in ANSI/IEEE C57.12.00.

6.3.4.3 Material

The instruction nameplate shall be made of corrosion-resistant material.

6.3.5 Kilovolt-ampere rating on tank

(See item 31 in Tables 7, 8, and 15.) The kilovolt-ampere rating, in Arabic numerals 2-1/2 inches (64 mm) high, shall appear on the tank of pole-mounted transformers near the low-voltage bushings. These numerals may be applied by stenciling or by any other suitable means.

6.3.6 Connections for shipment by the manufacturer

6.3.6.1 High-voltage windings having taps shall be connected for the rated voltage.

6.3.6.2 High-voltage windings of single-phase transformers designed for series-multiple operation shall be connected for the series voltage.

ANSI C57.12.20-1997

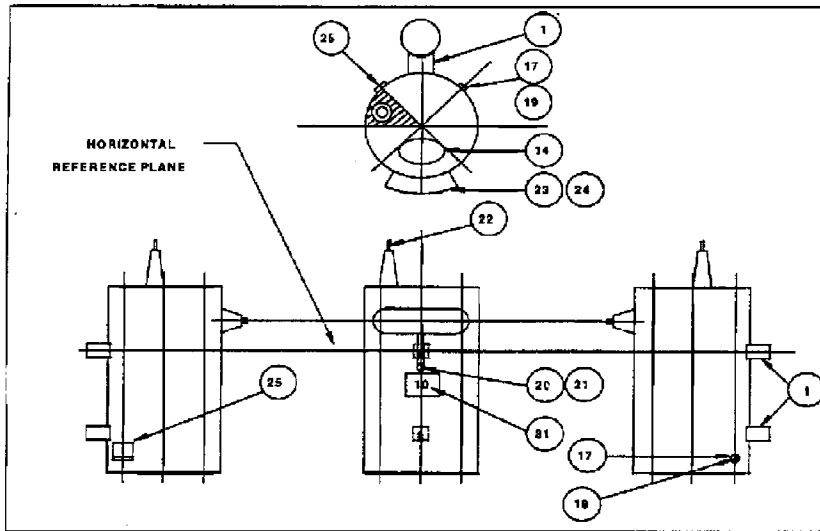

Item Number	Section Reference	Accessory Equipment	kVA 10 - 50	kVA 75 - 100	kVA 167	kVA 250 - 500
1	6.5.2	Support lug - Type	A	B	B	C
5	6.2.3	Liquid-level marking	X	X	X	X
9	6.2.1	Tap Changer (when specified)	X	X	X	X
14	6.5.1	Handhole in cover (1)	X	X	X	X
16	6.2.4	Lifting Lugs	X	X	X	X
17	6.5.4.1	Tank grounding provision	X	X	X	X
19	6.5.4.2	Tank grounding connector	X	X	X	X
20	6.5.4.3	Low-voltage grounding connection (2)	X	X	---	---
21	6.5.4.4	Low-voltage grounding provision (3)	X	X	X	---
22	6.1.2.2	High-voltage bushing terminals	X	X	X	X
23	6.1.2.3	Low-voltage bushing terminals	X	X	X	X
24	6.1.1.2	Low-voltage bushing arrangement	X	X	X	X
25	6.3.4.1.1	Nameplate Location	X	X	X	X
30	6.3.4.2	Nameplate - Type	A	A	A	A
31	6.3.5	kVA rating on tank	X	X	X	X
32	6.2.5.1	Pressure-relief valve (4)	X	X	X	X
33	6.2.2	Series-multiple device (when specified)	X	X	X	X

(1) Supplied only on units with internal tap changers or series-multiple terminal boards.

(2) For 120/240 volts only.

(3) For 240/480 volts and 277 volts.

(4) Segment location not specified. Not required if cover design is in accordance with 6.2.5.2.

High-Voltage (kV)	12.47GrdY/7.2	4.16GrdY/2.40 x 12.47GrdY/7.20
	13.2GrdY/7.62	4.16GrdY/2.40 x 13.20GrdY/7.62
	13.8GrdY/7.97	8.32GrdY/4.80 x 12.47GrdY/7.20
	24.94GrdY/14.4	8.32GrdY/4.80 x 13.20GrdY/7.62
	34.5GrdY/19.92	12.47GrdY/7.2 x 24.94GrdY/14.40
		13.20GrdY/7.62 x 24.94GrdY/14.40

Low-Voltage (volts) Series-multiple: 600 and Below
Single-ratio: 5000 and Below

Figure 7 – Single Phase 10 – 500 kVA for pole mounting (single-position) single high-voltage cover bushings

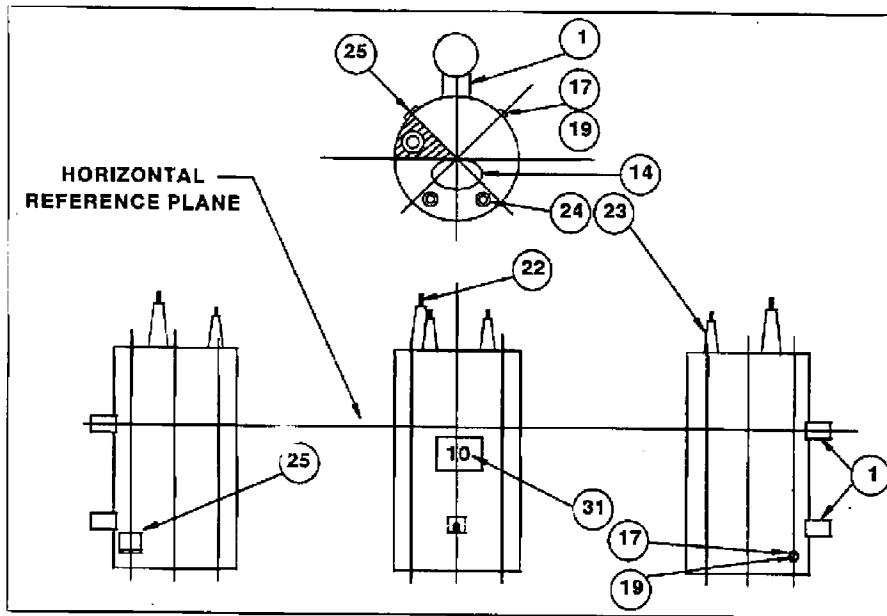

Item Number	Section Reference	Accessory Equipment	kVA 10 - 50	kVA 75 - 167	kVA 250 - 500
1	6.5.2	Support lug - Type	A	B	C
5	6.2.3	Liquid-level marking	X	X	X
9	6.2.1	Tap Changer (when specified)	X	X	X
14	6.5.1	Handhole in cover	X	X	X
16	6.2.4	Lifting Lugs	X	X	X
17	6.5.4.1	Tank grounding provision	X	X	X
19	6.5.4.2	Tank grounding connector	X	X	X
22	6.1.2.2	High-voltage bushing terminals	X	X	X
23	6.1.2.3	Low-voltage bushing terminals	X	X	X
24	6.1.1.2	Low-voltage bushing arrangement	X	X	X
25	6.3.4.1.1	Nameplate Location	X	X	X
30	6.3.4.2	Nameplate Type	A	A	A
31	6.3.5	kVA rating on tank	X	X	X
32	6.2.5.1	Pressure-relief valve (1)	X	X	X

(1) Segment location not specified. Not required if cover design is in accordance with 6.2.5.2.

High-Voltage (kV) 24.94GrdY/14.4

34.5GrdY/19.92

Low-Voltage (volts) Above 5000

Figure 8 – Single phase 50 – 500 kVA for pole mounting (single-position) single high-voltage cover bushings

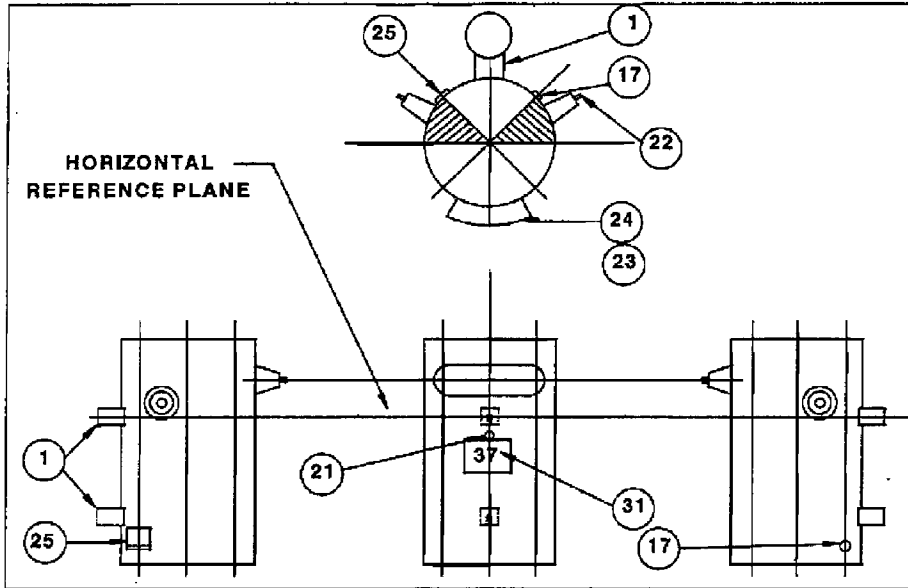

Item Number	Section Reference	Accessory Equipment	KVA 10 - 50	KVA 75 - 167	KVA 250 - 600
1	6.5.2	Support lug - Type	A	B	C
5	6.2.3	Liquid-level marking	X	X	X
9	6.2.1	Tap Changer (when specified)	X	X	X
16	6.2.4	Lifting Lugs	X	X	X
17	6.5.4.1	Tank grounding provision	X	X	X
21	6.5.4.4	Low-voltage grounding provision	X	X	—
22	6.1.2.2	High-voltage bushing terminals	X	X	X
23	6.1.2.3	Low-voltage bushing terminals	X	X	X
24	6.1.1.2	Low-voltage bushing arrangement	X	X	X
25	6.3.4.1.1	Nameplate Location	X	X	X
30	6.3.4.2	Nameplate - Type	A	A	A
31	6.3.5	kVA rating on tank	X	X	X
32	6.2.5.1	Pressure-relief valve (1)	X	X	X

(1) Segment location not specified. Not required if cover design is in accordance with 6.2.5.2.

High-Voltage (kV) 4.8/8.32Y and Below

Low-Voltage (volts) 600 and Below

Figure 9 – Single phase 10 – 500 kVA for pole mounting sidewall high-voltage bushings

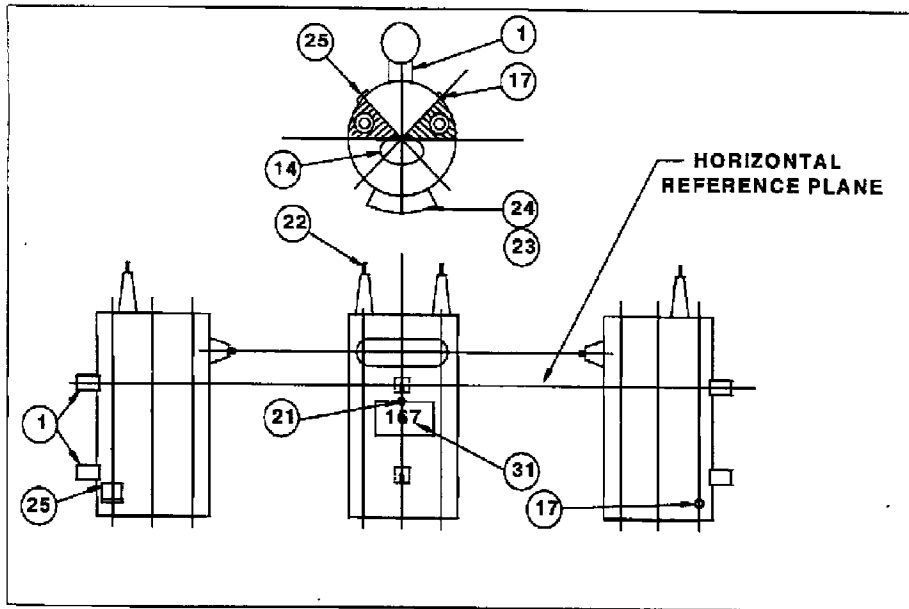

Item Number	Section Reference	Accessory Equipment	kVA 10 - 50	kVA 75 - 167	kVA 250 - 500
1	6.5.2	Support lug - Type	A	B	C
5	6.2.3	Liquid-level marking	X	X	X
9	6.2.1	Tap Changer (when specified)	X	X	X
14	6.5.1	Handhole in cover (1)	X	X	X
16	6.2.4	Lifting Lugs	X	X	X
17	6.5.4.1	Tank grounding provision	X	X	X
21	6.5.4.4	Low-voltage grounding provision	X	X	---
22	6.1.2.2	High-voltage bushing terminals	X	X	X
23	6.1.2.3	Low-voltage bushing terminals	X	X	X
24	6.1.1.2	Low-voltage bushing arrangement	X	X	X
25	6.3.4.1.1	Nameplate Location	X	X	X
30	6.3.4.2	Nameplate Type	A	A	A
31	6.3.5	kVA rating on tank	X	X	---
32	6.2.5.1	Pressure-relief valve (2)	X	X	X
33	6.2.2	Series-multiple device (when specified)	X	X	X

(1) Supplied only on units with internal tap changers or series-multiple terminal boards.
 (2) Segment location not specified. Not required if cover design is in accordance with 6.2.5.2.

High-Voltage (kV)	7.2/12.47Y	2.40/4.16Y x 7.20/12.47Y
	7.62/13.2Y	2.40/4.16Y x 7.62/13.2Y
	13.2/22.86Y to	4.80/8.32Y x 7.20/12.47Y
	14.4/24.94Y	4.80/8.32Y x 7.62/13.20Y
	12 to 13.8	7.20/12.47Y x 14.40/24.94Y
Low-Voltage (volts)	16.34 and 34.5	7.62/13.20Y x 14.40/24.94Y
	5000 and Below	

Figure 10 – Single phase – 10–500 kVA for pole mounting two high-voltage cover bushings

ANSI C57.12.20-1997

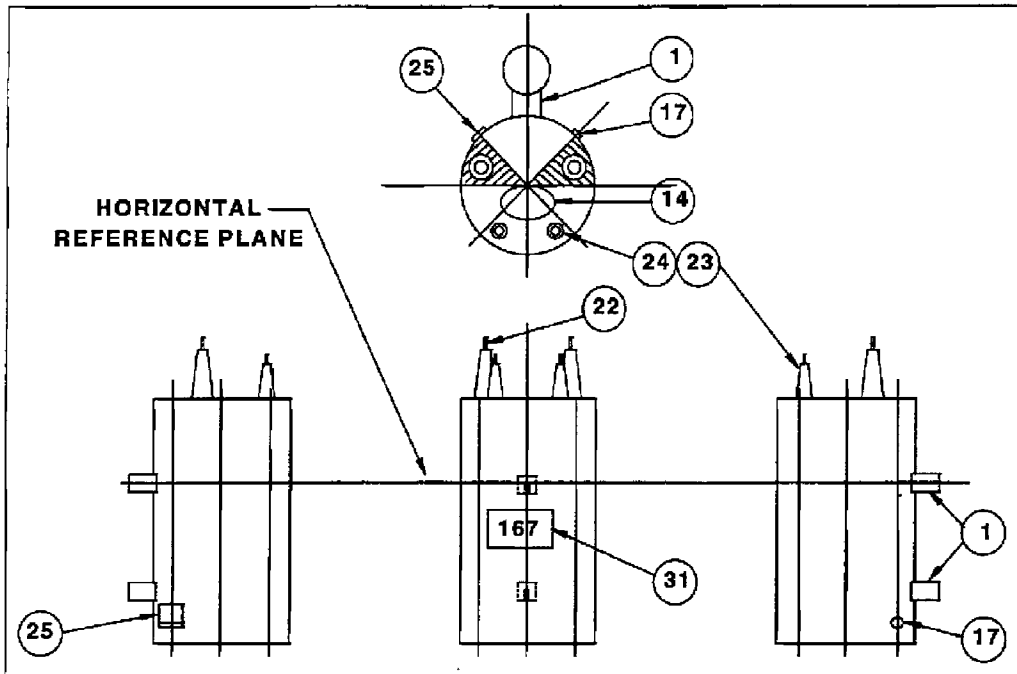

Item Number	Section Reference	Accessory Equipment	kVA		
			10 - 50	75 - 167	250 - 500
1	6.5.2	Support lug - Type	A	B	C
5	6.2.3	Liquid-level marking	X	X	X
9	6.2.1	Tap Changer (when specified)	X	X	X
14	6.5.1	Handhole in cover	X	X	X
16	6.2.4	Lifting Lugs	X	X	X
17	6.5.4.1	Tank grounding provision	X	X	X
22	6.1.2.2	High-voltage bushing terminals	X	X	X
23	6.1.2.3	Low-voltage bushing terminals	X	X	X
24	6.1.1.2	Low-voltage bushing arrangement	X	X	X
25	6.3.4.1.1	Nameplate Location	X	X	X
30	6.3.4.2	Nameplate Type	A	A	A
31	6.3.5	kVA rating on tank	X	X	X
32	6.2.5.1	Pressure-relief valve (1)	X	X	X

(1) Segment location not specified. Not required if cover design is in accordance with 6.2.5.2.

High-Voltage (kV) 13.2/22.86Y to 14.4/24.94Y
12 to 13.8, 16.34, and 34.5

Low-Voltage (volts) Above 5000

Figure 11 – Single phase 50 – 500 kVA for pole mounting two low-voltage cover bushings

ANSI C57.12.20-1997

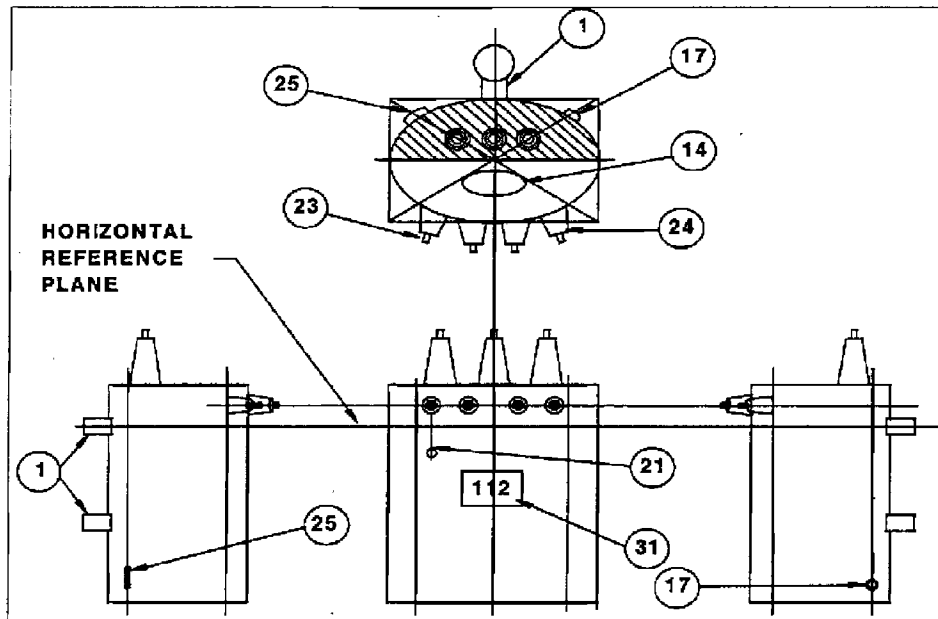

Item Number	Section Reference	Accessory Equipment	kVA 30	kVA 45 - 75	kVA 112-1/2 - 300	kVA 500
1	6.5.2	Support lug - Type	A	B	C	---
5	6.2.3	Liquid-level marking	X	X	X	X
9	6.2.1	Tap Changer (when specified)	X	X	X	X
14	6.5.1	Handhole in cover	X	X	X	X
16	6.2.4	Lifting Lugs	X	X	X	X
17	6.5.4.1	Tank grounding provision	X	X	X	X
21	6.5.4.4	Low-voltage grounding provision	X	X	X	X
22	6.1.2.2	High-voltage bushing terminals	X	X	X	X
23	6.1.2.3	Low-voltage bushing terminals (1)	X	X	X	X
24	6.1.1.2	Low-voltage bushing arrangement	X	X	X	X
25	6.3.4.1.1	Nameplate Location	X	X	X	X
30	6.3.4.2	Nameplate Type	A	A	A	A
31	6.3.5	kVA rating on tank	X	X	X	X
32	6.2.5.1	Pressure-relief valve (2)	X	X	X	X

(1) For above 600 volts, 6.1.2.2 is applicable.

(2) Segment location not specified. Not required if cover design is in accordance with 6.2.5.2.

NOTE: To maintain satisfactory mechanical and electrical clearances on small kVA ratings, it is permissible to encroach upon the shaded area.

High-Voltage (kV) 7.2 - 13.8
 12.47 - 13.2Y
 34.5GrdY/19.92
 13.8GrdY/7.97 and 24.94 GrdY/14.4

Low-Voltage (volts) 5000 and Below

Figure 13 – Three phase 30 – 300 kVA for pole mounting and 500 kVA for platform mounting

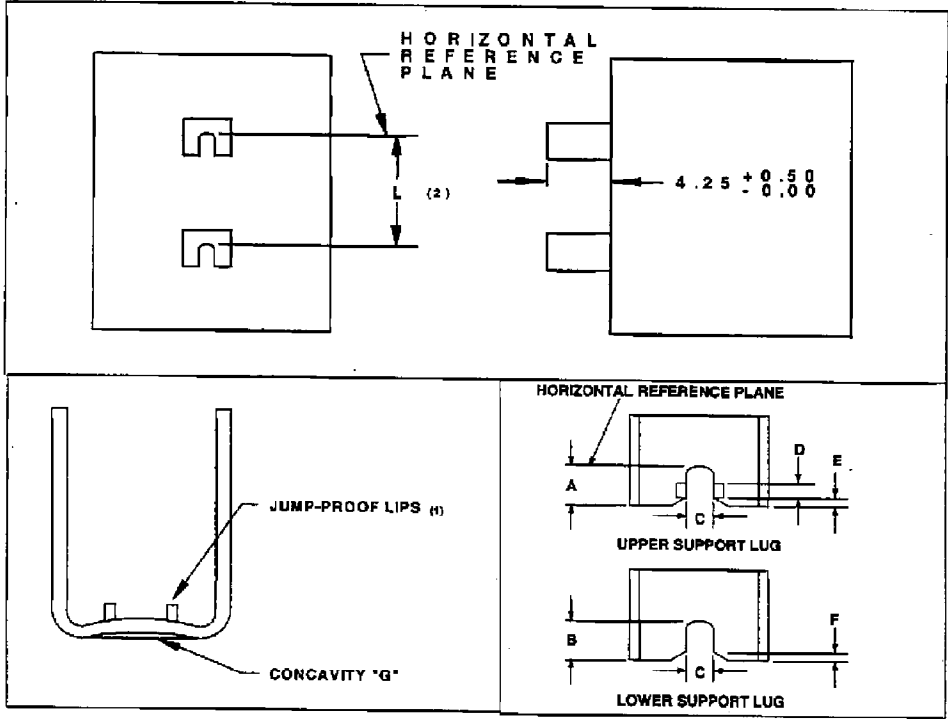

Dimensions	Support Lug A		Support Lug B	
	Inches	mm	Inches	mm
A	1 - 3/4	44.5	1 - 3/4	44.5
B	1 - 3/4	44.5	2 - 1/2	63.5
C ⁽³⁾	11/16	17.5	51/64	20.2
D	5/8	15.9	5/8	15.9
E	3/8	9.5	1/4	6.4
F	3/8	9.5	1/2	12.7
G	1/8	3.2	1/4	6.4

- (1) Jump-proof lips on upper support only.
 - (2) See Figures 1 and 2 for "L" dimension
 - (3) Tolerance for slot dimension shall be +/- 0.016 inch (+/- 0.4 mm).
- NOTES:
- (1) Support lugs are spaced 3/4 inch less than pole bolt spacing
 - (2) "A" Lugs to use 5/8 inch bolts. "B" lugs to use 3/4 inch Bolts. This is in accordance with the specifications in the latest revision of ANSI C135.1
 - (3) The dimensions shown must be maintained to obtain a standard mounting and are not intended to show construction details except for slot dimensions.
 - (4) Tolerance for all dimensions except where indicated shall be +/- 0.063 inch (+/- 1.6 mm)

Figure 14 – Support lugs A and B

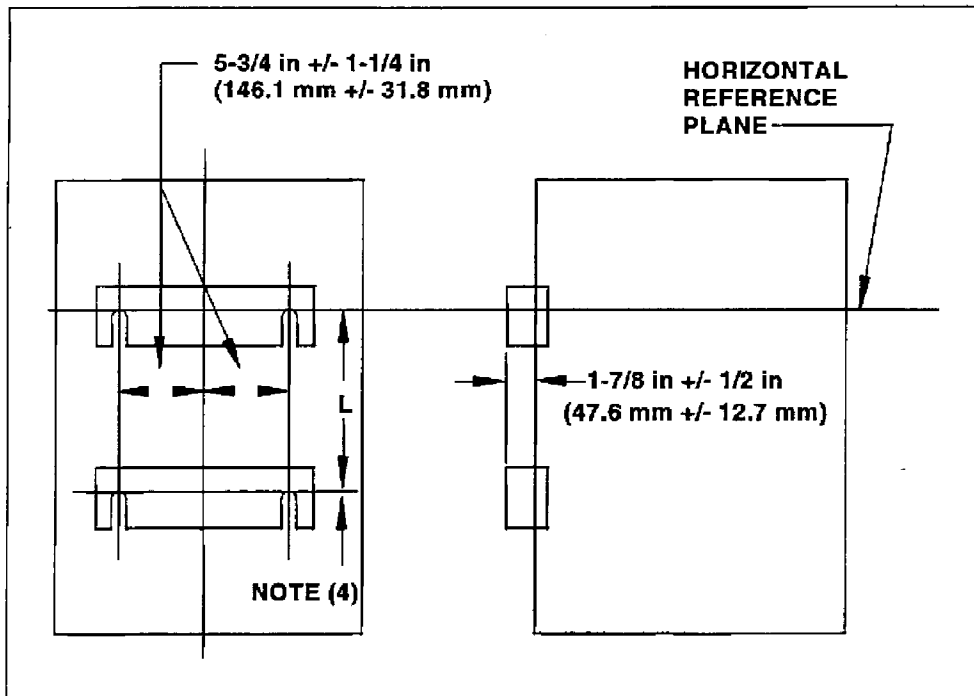

NOTES:

- (1) Support Lugs attached to transformer and intended for bolting to adapter plates for direct pole mounting or to conventional crossarm hangers
- (2) Slots shall be suitable for 5/8 inch (15.9 mm) bolts that are in accordance with the requirements of ANSI C135.1
- (3) Support Lug faces shall be in one plane.
- (4) For "L" dimension, see Figures 1 and 2
- (5) The dimensions shown shall be maintained to obtain a standard mounting and are not intended to show details of construction

Figure 15 – Support lug C

6.3.6.3 Low-voltage windings of single-phase transformers designed for both series-multiple and three-wire operation, where the connections are made inside the tank, shall be connected for three-wire operation.

6.3.6.4 Three-phase transformers with low-voltage windings rated 240 volts x 480 volts shall be connected for 480-volt operation.

6.4 Oil preservation

6.4.1 Distribution transformers shall have a sealed-tank oil-preservation system.

6.4.2 Sealed-tank construction is construction in which the interior of the tank is sealed from the atmosphere and the gas volume plus the oil volume remains constant. The transformer shall remain effectively sealed for a top oil temperature range of -5°C to +105°C for continuous operation at rated kilovolt amperes and under the operating conditions as described in ANSI/IEEE C57.91.

6.5 Tanks

6.5.1 Covers and handholes

The manufacturer's published data shall state if other than bolted-cover construction is used. Single-phase and three-phase transformers with cover bushings and internal tap changers shall have handholes on the cover. (See item 14 in Tables 7, 8, and 15.) These handholes shall be of adequate size and shall be suitably located to permit operation of the internal tap changer.

6.5.2 Support lugs

(See item 1 in Tables 7, 8, and 15.) Support lugs shall be designed to provide a safety factor of five when supported in a vertical plane from the top lug only. The safety factor of five shall be as defined for lifting lugs in 6.2.4. Interchangeable mounting to the maximum extent is accomplished by use of the following support lugs:

- (1) **Type A.** An upper and lower support lug shall be provided for direct-pole mounting. They shall be designed in accordance with Figure 14 and located as shown in Figures 1 and 2.
- (2) **Type B.** An upper and a lower support lug shall be provided for direct pole mounting. They shall be designed in accordance with Figure 14 and located in accordance with Figures 1 and 2.
- (3) **Type C.** Lugs shall be provided for mounting the transformer by means of auxiliary devices. They shall have dimensions in accordance with Figure 15 and be located as shown in Figures 1 and 2.

6.5.3 Tank finish

Unless otherwise specified, the tank finish shall conform to Light Gray Number 70, Munsell Notation 5BG 7.0/0.4.

ANSI C57.12.20-1997

6.5.4 Tank grounding provisions

6.5.4.1 Tank grounding provision

(See item 17 in Tables 7, 8 and 15.) The tank grounding provision shall consist of a steel pad with a 1/2-inch-13-NC tapped hole, 7/16 inch (11 mm) deep, and located near the bottom of the tank as shown in Figures 6-13. The threads shall be protected by a corrosion-resistant flanged cup pressed into the threaded opening of the ground pad.

6.5.4.2 Tank grounding connector

(See item 19 in Tables 7 and 8.) The tank grounding connector shall be a solderless connector that will accommodate AWG conductor size Number 8 solid to Number 2 stranded (on single-phase transformers only).

6.5.4.3 Low-voltage grounding connection

(See item 20 in Tables 7 and 8.) The low-voltage grounding connection shall be an external copper link of adequate size (to handle the short-circuit test in accordance with ANSI/IEEE C57.12:90), securely connecting the low-voltage neutral terminal to the tank.

6.5.4.4 Low-voltage grounding provision

(See item 21 in Tables 7, 8, and 15.) The low-voltage grounding provision shall consist of a steel pad with a 1/2-inch-13-NC tapped hole, 7/16 inch (11 mm) deep. The threads shall be protected by a corrosion-resistant flanged cup pressed into the threaded opening of the ground pad.

7 Storage and installation

7.1 Storage

The transformer shall be stored in a vertical position and shall remain essentially in that position at all times, including transport to the site and during installation.

7.2 Installation

Equipment manufactured to this specification may be installed in areas where environmental and climatic conditions make operation at varying angles of tilt from the horizontal an important consideration. Under these circumstances, the user may wish to make a particular "angle of tilt" part of their specifications.

8 Design tests for fault current capability of overhead distribution transformer enclosures

8.1 Objective

This test procedure has been designed to determine the ability of an overhead transformer tank or enclosure to withstand a shock- or impulse-type application of internal pressure. It is recognized that the test conditions must ultimately be described in terms of the energy applied, with the pressure wave defined by the rate of rise, peak pressure, duration, and total energy under the curve. However, at this time sufficient information is not available to so describe an applicable pressure wave. For the interim period until such knowledge is available, this test procedure is based upon defining the electrical conditions associated with generating a particular shock or impulse pressure wave which may be used as a measure of tank or enclosure strength.

This test procedure is not intended to include all possible conditions that may occur in service under fault conditions, but rather to establish a meaningful test which is repeatable and capable of duplication in various laboratories and test situations.

The test is intended as a design test to be made on new transformer tanks with a new tank assembly subjected to no more than two faults or pressure shots. It is not intended to provide data for current limiting fuse application.

Some faults can quickly develop high pressures in the transformer enclosure. The rate of pressure rise and the ultimate tank pressure may vary for different faults. These design tests are to be made on transformer enclosures to demonstrate their capability to withstand pressure changes due to specified faults.

8.2 Definitions

8.2.1 Enclosures

The complete transformer housing: tank, cover, band, etc., that contains the oil, the core and coil, the accessories, etc., of an overhead or pole distribution transformer.

8.2.2 Internal fusible element

An expulsion fuse that operates in the transformer oil.

8.2.3 Back-up protection

Devices external to the transformer enclosure to limit the duration or the potential duration of the flow of current to a fault.

8.2.4 A test

Two faults in a given enclosure.

8.2.5 A fault

An electrical condition designed to draw a specified value of current.

8.3 General requirements

The transformer to be tested shall be a new unit, complete with its core and coil, bushings, etc. The test shall be conducted at ambient temperature with an initial internal pressure from 6 to 7 psig. The transformer being tested shall be securely supported by its hanger brackets and mounted clear of the earth. The testing requirements of ANSI/IEEE C37.40 and C37.40a and ANSI/IEEE C37.41 shall be followed. The fault current shall be symmetrical. A new enclosure shall be used for each test. A test shall consist of two faults. The second fault shall be accomplished by reusing, "as specified by the manufacturer," all of the original components in the enclosure. Provision shall be made for venting in a safe manner and internal pressure which remains after each fault.

If specified, the manufacturer shall provide a test report. This report shall describe tests on representative production samples of each enclosure diameter with its minimum designed air space.

ANSI C57.12.20-1997

8.4 Tests

Two tests are covered in this standard. Test Number 1 with a high current arcing fault, without internal fusible elements, shall be conducted on each enclosure diameter with its minimum designed air space. The minimum designed air space must consider production tolerances.

In addition, Test Number 2, with an internal fusible element, shall be conducted on each enclosure diameter utilizing the internal fusible elements. This test covers the interruption of these fusible elements for both rated interrupting and the lower fault value of current, as identified in 8.6.

It is the intent of this test to utilize the highest energy release fuse element for each enclosure. This is probably the highest interrupting rated fuse element provided for the highest voltage class. The transformer should not have a secondary breaker or any other secondary protection.

8.5 Test number 1 – an arcing fault in an enclosure

8.5.1 First fault

A simulated internal fault shall be provided. This fault shall consist of a 1-inch arc-gap mounted horizontally and located 1 inch above the core clamps. This gap shall be bridged initially by an 0.0605-inch diameter or smaller copper wire. The gap shall be connected between the high-voltage terminals or from one high-voltage terminal to ground. The mounting blocks or terminals of the gap shall consist of copper-bearing material and shall have flat surfaces from 1/4 to 3/4 inch in diameter or in width. These gaps shall be designed to maintain this 1-inch arc gap for the duration of the fault. The transformer coil shall not be electrically connected in this test circuit. The power source shall be 7.2 kV and adjusted to supply a current of 8000 rms symmetrical amperes.

As this arcing fault will not be self-clearing, back-up protection shall be provided to clear the circuit in approximately 1/2 to 1 cycle, which is a typical clearing time for an external distribution fuse cutout. A cutout with up to a 25K fuse link shall be used to provide back-up protection. A current-limiting device, such as a fuse, cannot be included in the back-up protection.

8.5.2 Second fault

For the second fault, the fault described in 8.5.1 shall be repeated.

8.6 Test number 2 – for enclosures with internal fusible elements

For the tests in 8.6.1 and 8.6.2, the sequence of faults shall be either A and then B or B and then A.

8.6.1 "A" fault

The A fault shall be a bolted line-to-ground on the load side of the fusible element. The power source shall apply the rated voltage of the transformer and shall be capable of delivering the rated interrupting current of the fusible element or 8000 rms symmetrical amperes, whichever is less. The transformer coil shall not be electrically connected in this test circuit.

Back-up protection should be provided to clear the faults in approximately two cycles after the total clearing time of the internal fusible element.

8.6.2 "B" fault

The B fault shall be applied externally to the enclosure at the low-voltage terminals of the transformer, shorting all low-voltage terminals with the required impedance. The transformer coil shall be electrically

connected in this test circuit. This fault should draw 25 times rated transformer current. For transformers with 4-percent impedance or higher, the current will be limited by the transformer impedance. The power source shall be adjusted to the rated voltage of the transformer. The fault current shall operate the fusible element.

Back-up protection should be provided to clear the fault in approximately two seconds after total clearing time of the internal fusible element.

8.7 Test results

8.7.1 No mechanical components from the transformer enclosure shall be propelled or dropped from the tank during the tests. There shall be no rupture of the tank casing or seams.

8.7.2 There shall be less than one quart of oil emitted and no expulsion of flaming oil during the tests.

8.7.3 No oil shall continue to leave the inside of the transformer enclosure after the completion of the fault.

8.7.4 The transformer shall not be dislodged from its mounting.

ANNEX A

Informational

(This appendix is not part of American National Standard C57.12.20-1997, but is included for information only)

A.1 Auxiliary mounting devices

Auxiliary mounting devices for use with transformers covered by ANSI C57.12.20-1997 are not manufactured, stocked, or furnished by manufacturers of transformers. They were developed prior to 1953 by The Joint Committee of the Edison Electric Institute and the National Electric Manufacturers Association on Standards for Distribution Transformers for use with single-phase transformers 100 kVA and smaller and three-phase transformers 112-1/2 kVA and smaller.

At that time, larger transformers were furnished with a bracing lug, rather than support lug C, and the bracing lug was not designed to carry the weight of the transformer. Furthermore, the maximum size transformer with support lug B was 50 kVA single-phase and 45 kVA three-phase.

During the ensuing years, advances in technology have reduced sizes and weights of distribution transformers, and support lug B is presently furnished with 167 kVA single-phase and 75 kVA three-phase transformers. The availability, from certain pole-line hardware manufacturers, of cluster mounts that include adapter plates for support lug C and that are used in transformer installations, and the utilization of armless pole-line construction with direct pole mounting of transformers with support lugs A and B have virtually eliminated the use of crossarm hangers.

The following is included in this Appendix as an aid to those users who have transformer installations utilizing such auxiliary mounting devices.

- (1) Type C adapter plates (see Figure A1) are for direct pole mounting of transformers having type C support lugs, subject to the stress limitations of the supporting structure. These adapter plates must provide a safety factor of 5 as described in paragraph 6.5.2 of this document.
- (2) Crossarm hanger T1 (see Figure A2) is for crossarm mounting of transformers having type A support lugs with spacing (L dimension) of 11-1/4 inches.
- (3) Kicker K1 (see Figure A2) is for use with crossarm hanger T1.
- (4) Crossarm hanger T2 (see Figure A2) is for crossarm mounting of transformers having type A or B support lugs with spacing (L dimension) of 23-1/4 inches.
- (5) Kicker K2 (see Figure A2) is for use with crossarm hanger T2.
- (6) Crossarm hanger C1 (see Figure A3) is for crossarm mounting of transformers having type C support lugs with spacing (L dimension) of 24 inches.
- (7) Crossarm hanger C2 (see Figure A3) is for crossarm mounting of transformers having type C support lugs with spacing (L dimension) of 36 inches.

ANSI C57.12.20-1997

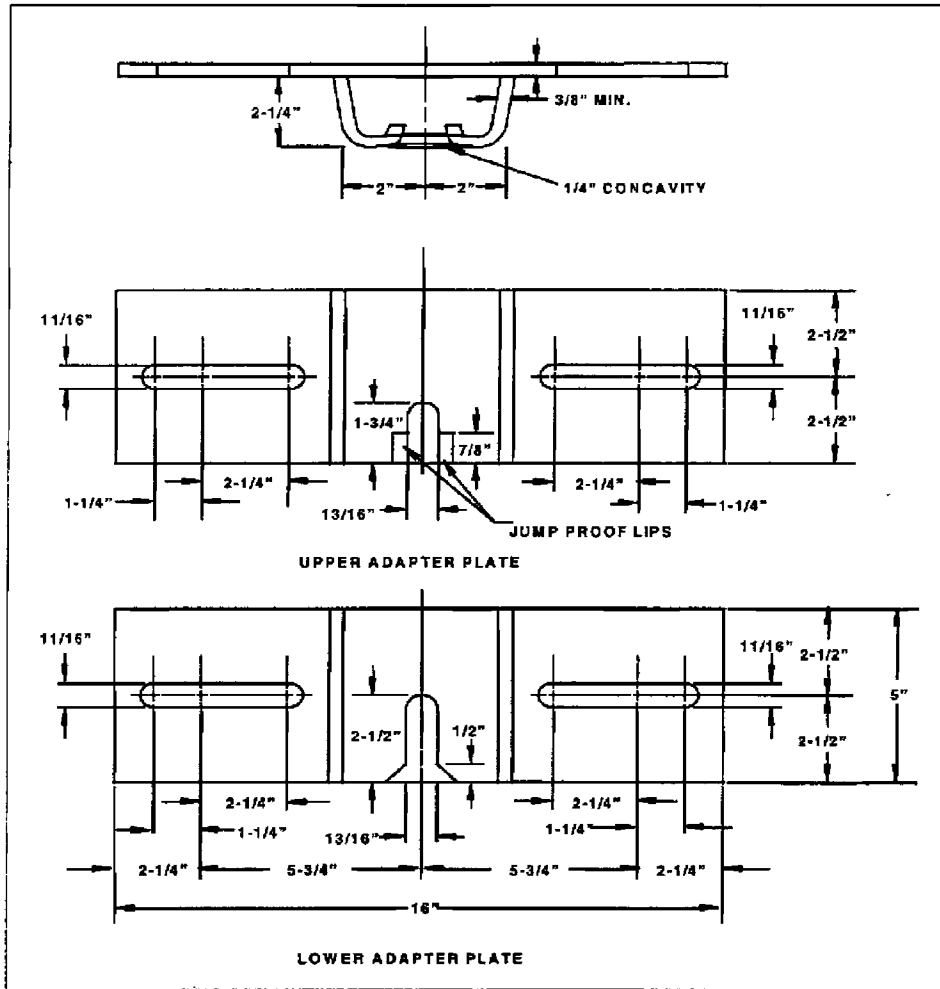

NOTES:

- (1) Upper and lower adapter plates are identical, except bolt slot is 3/4 inch longer and jump proof lips are omitted on lower plate and bottom of slot is chamfered.
- (2) Use 5/8 inch bolts to bolt adapter plates to transformer support lugs. Use 3/4 inch bolts to bolt adapter plates to pole
- (3) For ease of inserting pole bolts in adapter plate slots and for tolerance in boring pole bolt holes, the distance between the tops of bolt slots is 3/4 inch less than the bolt spacing, and lower edges of slots are chamfered on lower adapter plates.
- (4) Tolerances except where indicated otherwise, shall be +/- 1/16 inch, except that adapter plate tolerances shall be +/- 1/64 inch.
- (5) Adapter plates, nuts, and bolts shall be hot-dip galvanized, with finished dimensions that are in accordance with the specifications of ANSI C135.1.
- (6) Adapter plates must provide a safety factor of 5 as described in paragraph 6.5.2 of this document.

Figure A1 – Type C adapter plates

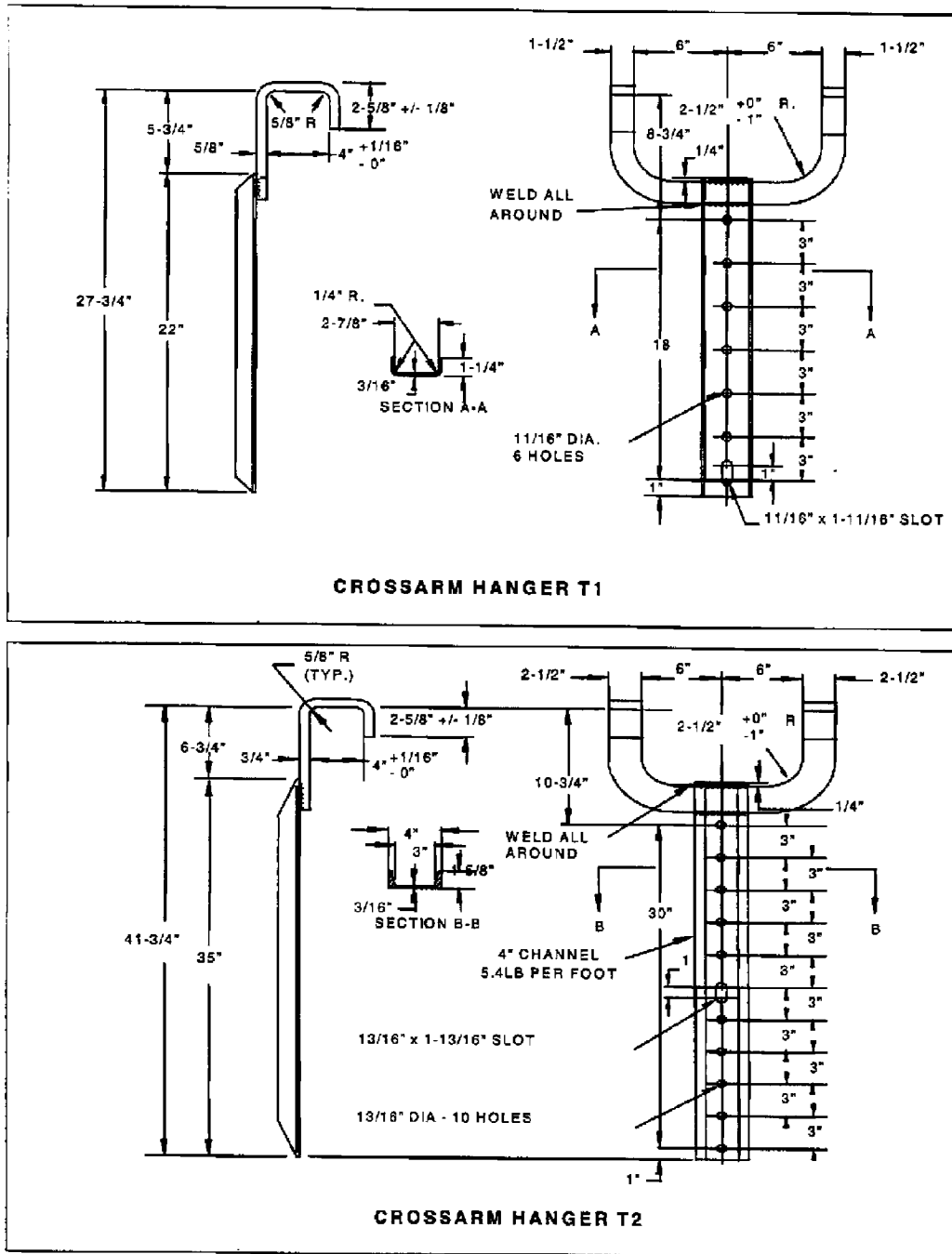
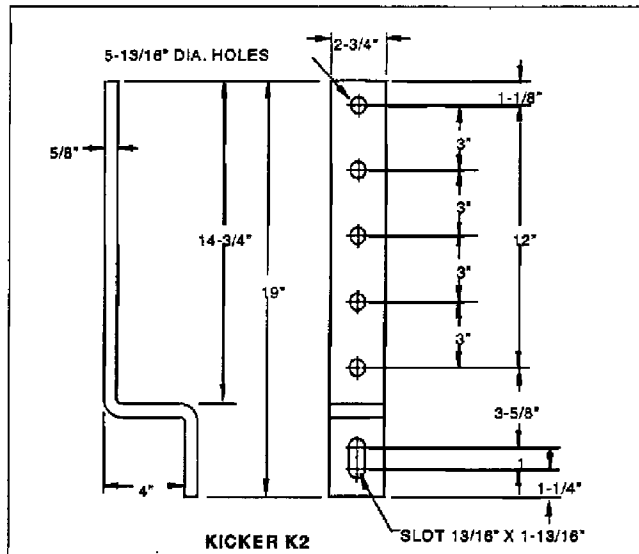
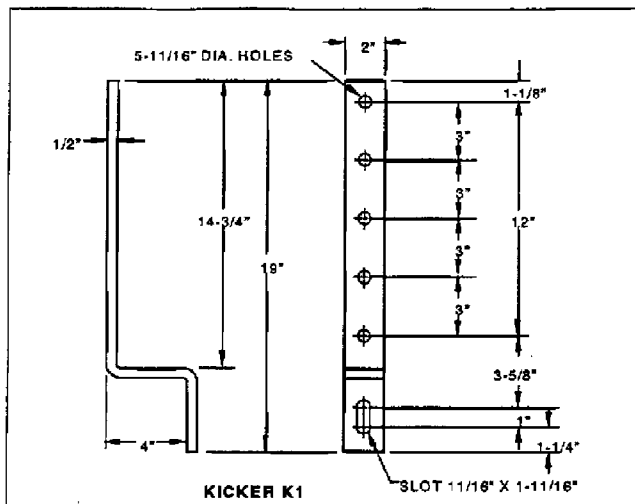

Figure A-2 – T-crossarm hangers and kickers



Crossarm Hanger	Kicker Size	Number of 5/8 inch Bolts and Nuts		Number of 3/4 inch Bolts and Nuts	
		Hanger	Kicker	Hanger	Kicker
T1	K1	2	1	—	—
T2	K2	—	—	2	1

NOTES:

- (1) Tolerances, except where indicated otherwise, shall be +/- 1/16 inch, except that bolt hole and slot tolerances shall be +/- 1/64 inch.
- (2) All bolts and nuts to be square-headed, NC threads.
 - (a) 5/8 inch bolts, 2-1/2 inches long, and threaded within 3/16 inch or less of bolt head.
 - (b) 3/4 inch bolts, 2-1/2 inches long, and threaded within 3/8 inch or less of bolt.
- (3) All T-crossarm hangers, kickers, nuts, and bolts shall be hot-dip galvanized.

Figure A-2 – T-crossarm hangers and kickers (Continued)

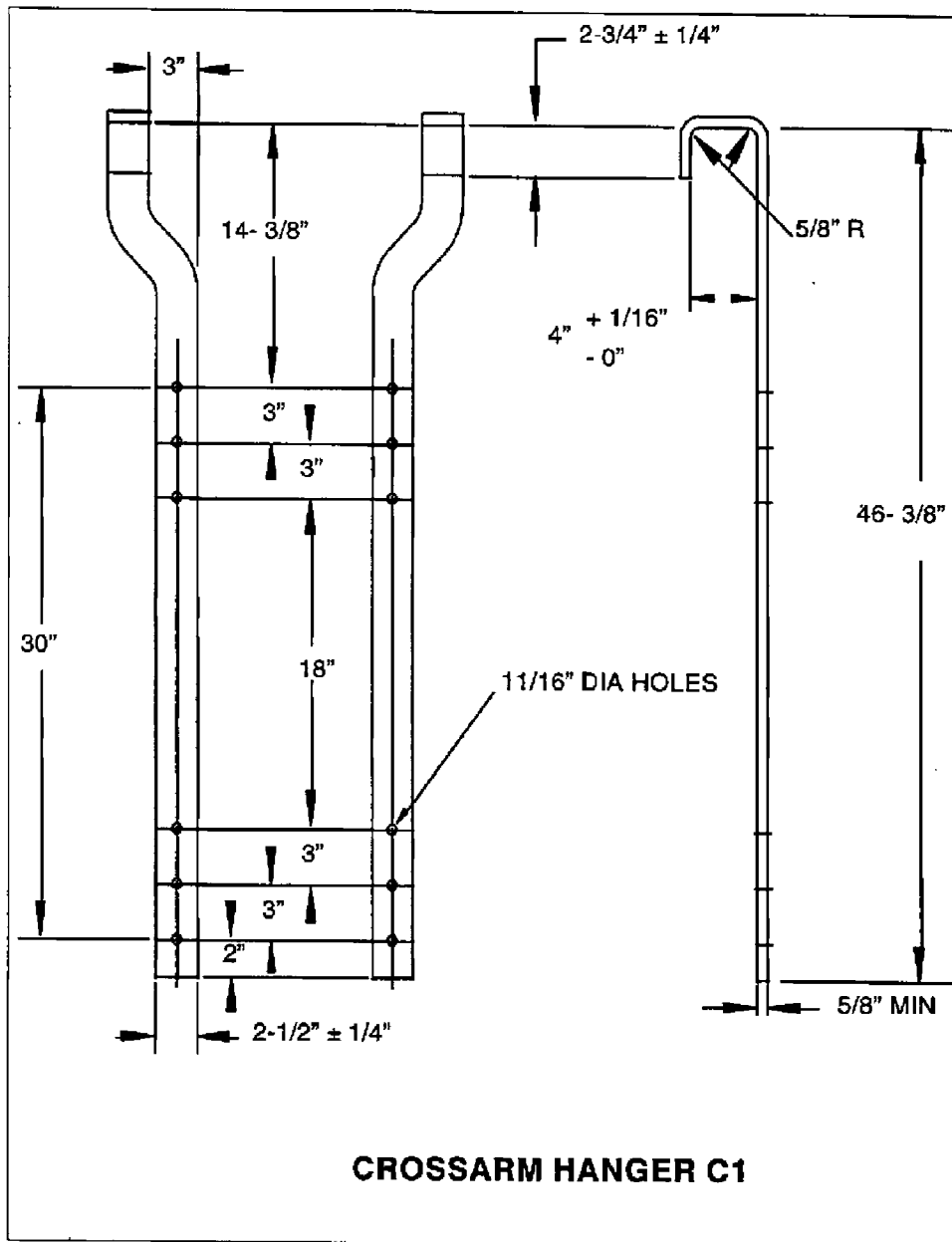
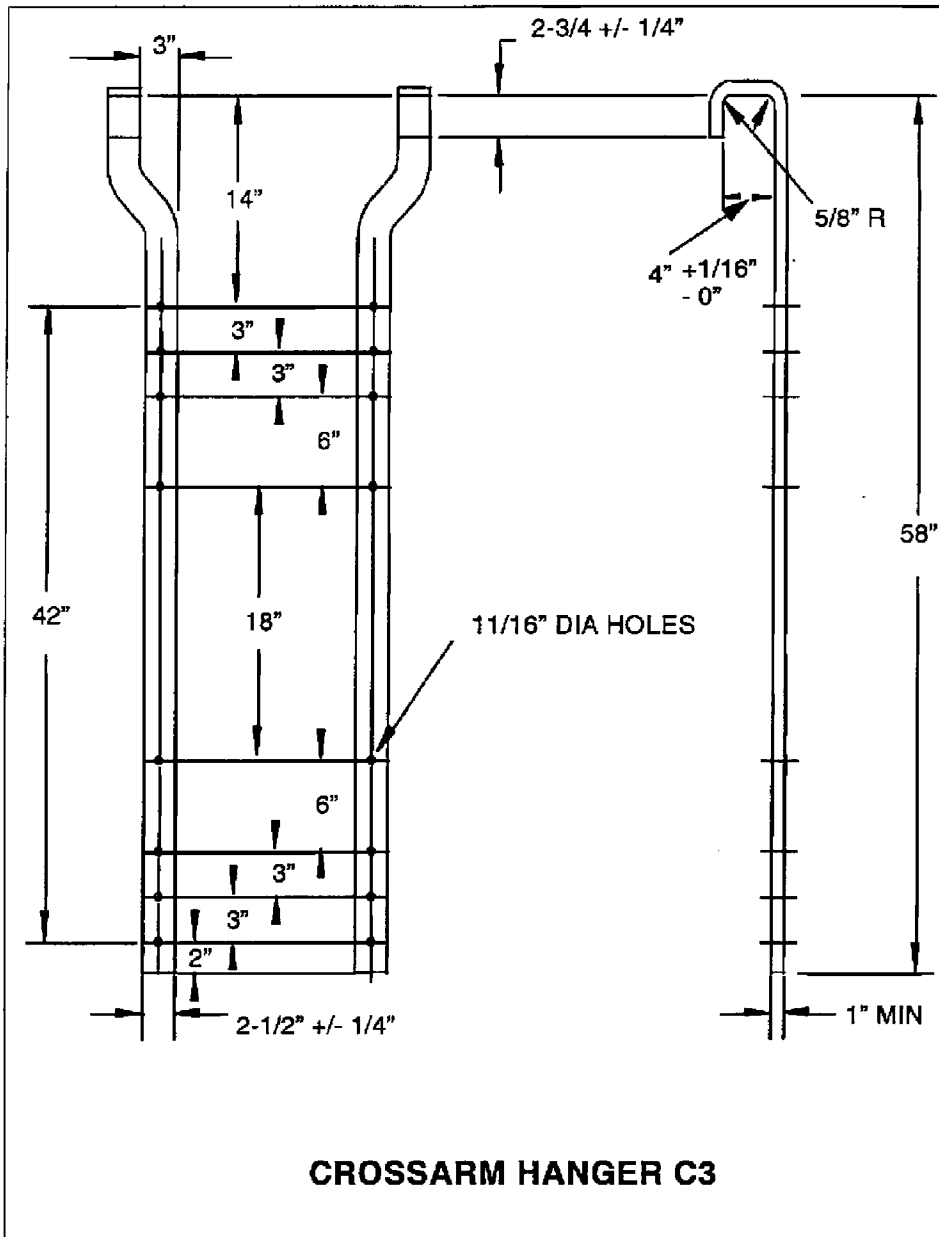

Figure A-3 – Crossarm hangers

ANSI C57.12.20-1997



NOTES:

- (1) Crossarm hangers shall be hot-dip galvanized.
- (2) C1 and C3 crossarm hangers each to be equipped with four 5/8 inch NC square head bolts, 2-1/2 inches long, and threaded to within 3/16 inch or less of bolt head, and square nuts.
- (3) Tolerances, except where indicated otherwise, shall be +/- 1/16 inch, except that bolt hole and slot tolerances shall be +/- 1/64 inch.

Figure A-3 – Crossarm hangers (Continued)

A-6