

# Protection and Commissioning of Multifunction Digital Transformer Relays at Medium Voltage Industrial Facilities

Charles J. Mozina, *Member, IEEE*

**Abstract**—The application of multifunction digital relays to protect medium voltage power transformers has become a common industrial practice. Industrial transformers, unlike utility transformers, frequently use neutral grounding resistors to limit ground current during faults to the 200–400-A level on medium voltage systems. This paper will discuss why these types of transformers require sensitive ground differential protection. The paper will also discuss the basics of transformer protection including phasing standards, through-fault withstand capability, differential/fusing/overcurrent protection, slope, current transformer (CT) requirements, and harmonic restraint, and communicating these properly to new digital relays. The rationale for providing transformer overexcitation protection on all major transformers within mill facilities is also addressed. Advancements in digital technology have allowed relay manufacturers to include more and more relay functions within a single hardware platform as well as address increasingly more transformer winding configurations. This has resulted in digital transformer relays requiring an Einstein to set and an Edison to commission. Since there are few Einsteins or Edisons among us, the next generation of transformer relays needs to concentrate on this complexity issue in addition to technical improvements. This paper addresses these issues that the author believes are the major shortcomings of existing digital transformer protective relays.

**Index Terms**—American National Standards Institute (ANSI), E-M relays, harmonic restraint, International Electrotechnical Commission (IEC), inrush, low-resistance grounding, multifunction digital relay, overexcitation, slope, V/Hz.

## I. INTRODUCTION

### A. Transformer Protective Zones

**T**RADITIONALLY, the protection of medium voltage power transformers at industrial facilities has been relegated to the application of transformer phase differential and backup overcurrent relays to provide short-circuit protection. With the advent of modern multifunction transformer relay packages, phase differential and overcurrent are only two of the many protection functions that are incorporated into these packages. Fig. 1 shows both the primary and the backup zone protection areas typically provided by today's digital

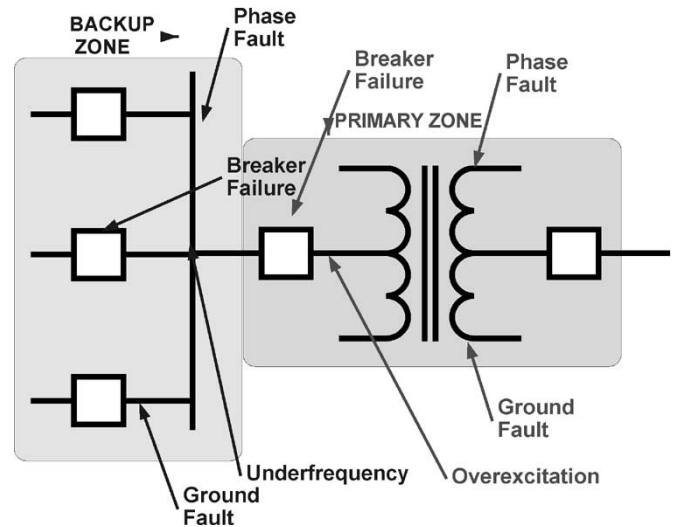

Fig. 1. Transformer zone protection.

transformer protection packages. At many industrial facilities, many of these protective functions are provided by discrete electro-mechanical (E-M) relays or not applied at all because of economic considerations.

This flexibility and added functionality has resulted in complicated relays that are difficult to set and commission. Also, the failure of the hardware platform typically results in the loss of all protective functions within the transformer package and must be considered in the design of the protection system to maintain separate primary and backup protection. This paper addresses these issues and provides practical solutions. These shortcomings, however, are far outweighed by the many advantages of digital relays. Users have also seen the many benefits of digital relays with almost all new installations using this technology.

### B. Causes of Transformer Failure

Contrary to popular belief, transformers do experience short circuits and abnormal electrical conditions that result in their failure. As transformers become older, the likelihood of failure increases as insulation begins to deteriorate. An example of one such abnormal condition is overexcitation, which is discussed in this paper. Many industry experts have concluded that overexcitation and through-faults are more detrimental to transformer life than load-associated aging [1].

Paper PID-05-13, presented at the 2005 IEEE Pulp and Paper Industry Conference, Jacksonville, FL, June 19–23, and approved for publication in the IEEE TRANSACTIONS ON INDUSTRY APPLICATIONS by the Pulp and Paper Industry Committee of the IEEE Industry Applications Society. Manuscript submitted for review June 23, 2005 and released for publication August 31, 2005.

The author is with Beckwith Electric Company, Inc., North Largo, FL 33773 USA (e-mail: cmozina@aol.com).

Digital Object Identifier 10.1109/TIA.2005.858278

TABLE I  
CAUSES OF TRANSFORMER FAILURES

Cause	% of Failures
Insulation Failure	26%
Manufacturing Problems	24%
Unknown	16%
Loose Connections	7%
Through Faults	5%
Improper Maintenance	5%
Oil Contamination	4%
Overloading	4%
Fire/Explosions	3%
Lightning	3%
Floods	2%
Moisture	1%

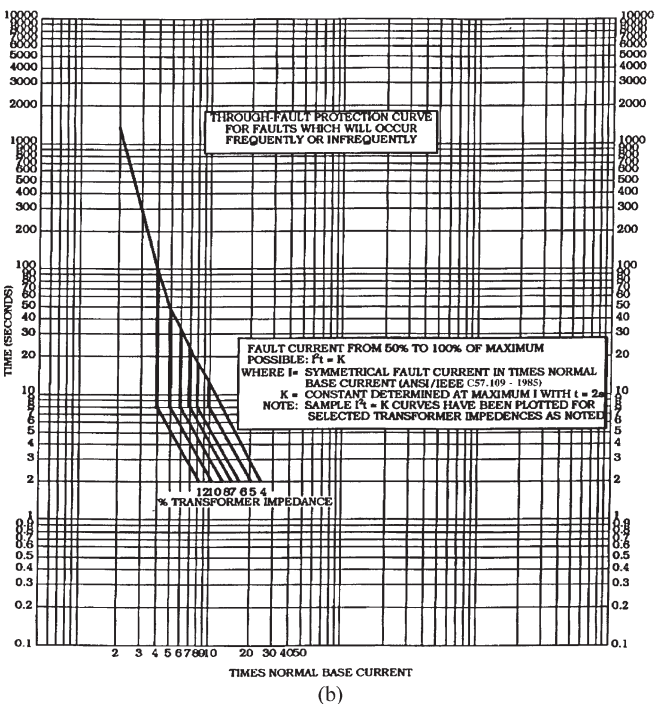
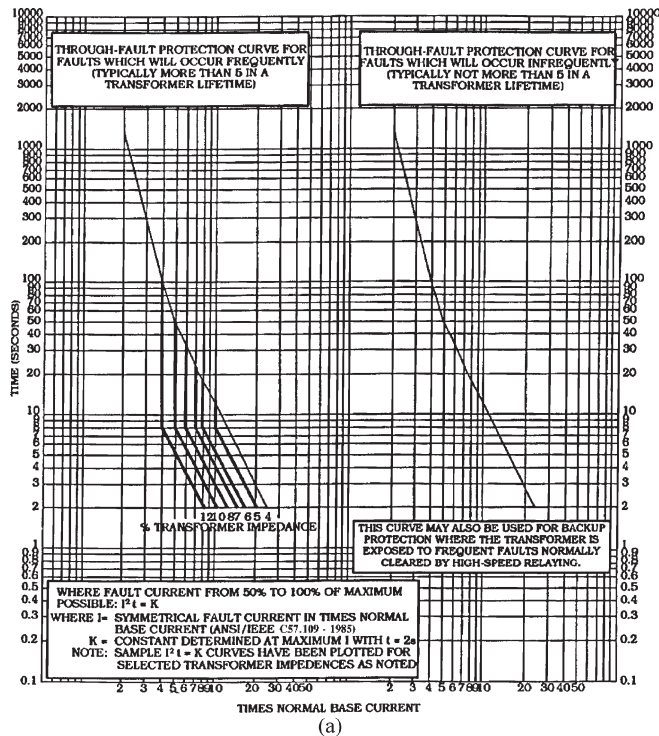

Fig. 2. (a) IEEE Category III transformer—5–30 MVA. (b) IEEE Category IV transformer—above 30 MVA.

Through-fault failures were a major industry concern in the U.S. during the late 1970s and 1980s when the industry experienced an unusually large number of through-fault failures due to design deficiencies. As a result, the IEEE Transformer Committee developed guidelines (C57.109-1985) for duration and frequency of transformer through-faults. Fig. 2(a) and (b) depicts these requirements for Category III (5–30 MVA) and Category IV (above 30 MVA) transformers. The smaller Category III transformer through-fault standards are defined

by two sets of curves—one for frequent faults and one for infrequent faults. Two sets of curves are used since this size of transformer is often used in utility distribution substations and are subjected to frequent through-faults and multiple automatic reclosing attempts. The multiples of normal current in Fig. 2(a) and (b) are based on the OA rating of the transformer being 1.0 per unit base current. These curves should be used when developing transformer time overcurrent relay settings.

The through-fault effects on transformer failure are somewhat mitigated in medium voltage industrial installations because most through-faults are line-to-ground faults and fault current is limited by 200–400-A grounding resistors in the transformer neutral. A detailed analysis of transformer failures [2] conducted by the Hartford Steam Boiler (HSB) Inspection and Insurance Company (HSB is a major electrical equipment insurer) breaks down the causes of transformer failures based on the transformers they insure. Table I shows the breakdown of the causes of failure. One of HSB’s conclusions is that whatever the cause of failure, age compounds the problem. Therefore, the proper protection of aging transformers warrants careful attention from mill engineers.

## II. TRANSFORMER BASICS

Transformer grounding and winding configuration (wye or delta) play a large role in the development of the protection for a specific transformer.

### A. Transformer Grounding and Winding Configuration

At most medium voltage industrial facilities, the main incoming transformer that provides the tie to the utility system is generally configured to be a delta primary–wye grounded secondary transformer. The secondary wye winding is generally grounded through a grounding resistor. Typically, these

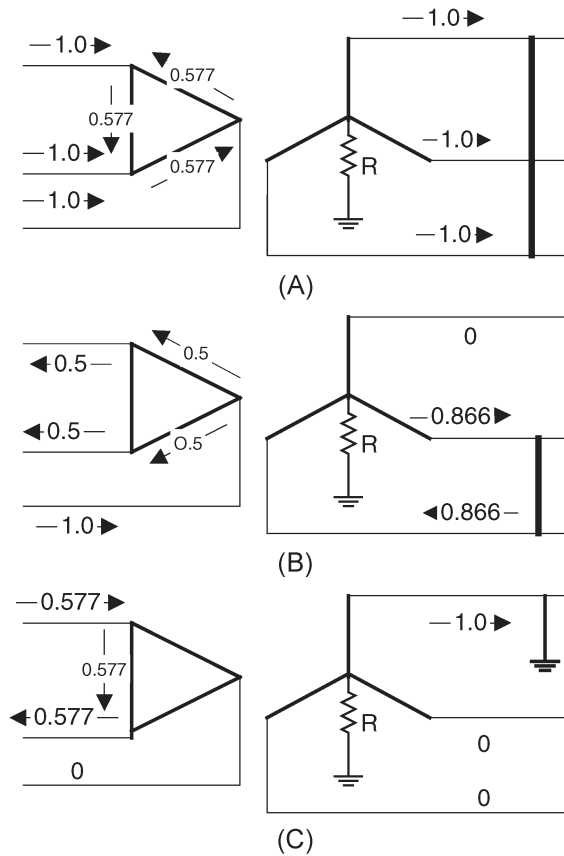

Fig. 3. Delta-wye transformer fault current distribution. (a) Three-phase fault. (b) Phase-to-phase fault in pu of three-phase fault. (c) Line-to-ground fault.

resistors reduce ground current to 200–400 A. There are three major reasons to use a secondary grounding resistor to reduce industrial system ground current:

- 1) reducing ground current reduces damage at the point of fault;
- 2) reducing ground current reduces the fault current level that industrial equipment (transformers, cables, etc.) must carry during fault clearing;
- 3) reducing ground current minimizes the voltage dip on the industrial system for a line-to-ground fault.

The use of a delta-wye transformer introduces a rearrangement of fault current on the primary of the transformer for secondary faults that affect protection when overcurrent devices such as overcurrent relays or fuses are used. Fig. 3 illustrates how secondary fault currents are redistributed for various types of faults when viewed from the primary side of the transformer. Fault currents are shown in per unit (pu). Fuses—which are commonly used by utilities to protect solidly grounded transformers of 10 MVA and smaller—cannot be used to protect transformers that are grounded through grounding resistors as shown in Fig. 3. As an example, if a secondary ground fault current is limited to 400 A on a 10-MVA 138/13.8 kV transformer, a bolted secondary ground fault would only produce 23 A [see Fig. 3(c)] of fault current on the primary side of the transformer. This is less than the 42 A of full load current. Thus, it is not possible to fuse such a transformer because the fuses are

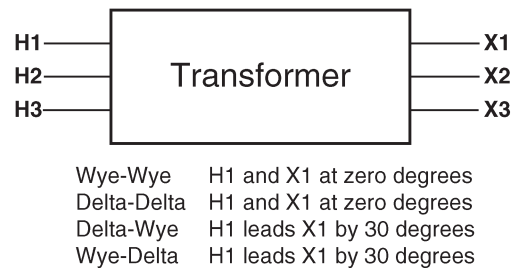

Fig. 4. IEEE/ANSI phase shifts.

not sensitive enough to detect secondary ground faults. These transformers must be protected by relays.

### B. Transformer Phasing Standards

There are two major phasing standards used worldwide for transformers. The American National Standards Institute (ANSI)/IEEE standard was developed by North American transformer manufacturers and is used in the U.S., Canada, and many other countries. The International Electrotechnical Commission (IEC) phasing standard was developed by European transformer manufacturers and is used in Europe and countries worldwide whose electric system was influenced by European manufacturers. Transformer protective relays that are sold worldwide must be able to handle both phasing standards, thereby adding to the complexity of digital transformer relays. Properly communicating the phase shift introduced by delta-wye transformers to a digital relay is the biggest source of setting errors in digital transformer relays. The level of complexity required to communicate transformer phase shift to a digital relay is one of the design features that differentiates one relay manufacturer's product from another.

IEEE/ANSI phasing standards are shown in Fig. 4. For delta-wye or wye-delta transformers, the primary (H) current leads the secondary current (X) by 30°.

How the 30° phase shift is accomplished within the transformer is a mystery to some engineers, but it is accomplished by the configuration of the delta winding within the transformer. Figs. 5 and 6 show how this is done for delta-wye and wye-delta transformers wound to meet IEEE/ANSI standards.

For IEEE/ANSI standard transformers, a simple way to communicate the phase shift is to determine how the delta winding is configured. One can look at a phasing diagram for the delta winding and easily determine if the A phase delta is delta AB (I<sub>a</sub>-I<sub>b</sub>) or AC (I<sub>a</sub>-I<sub>c</sub>) configured. The delta AB shifts the phase angle 30° in the positive direction with the delta current leading the wye current. The delta AC shifts phase angle 30° in the negative direction with the delta current lagging the wye current. Using this simple convention, it is possible to communicate the phase shift to a digital relay for IEEE/ANSI standard delta-wye transformers.

IEC phasing standards cannot use the method described above to communicate the phasing to a digital transformer relay. The Euro designation uses a clock system with each hour designated as a 30° increment of lagging phase angle from the X1 bushing to the H1 bushing. The clock is divided into 12 segments. Each segment number indicates the number of

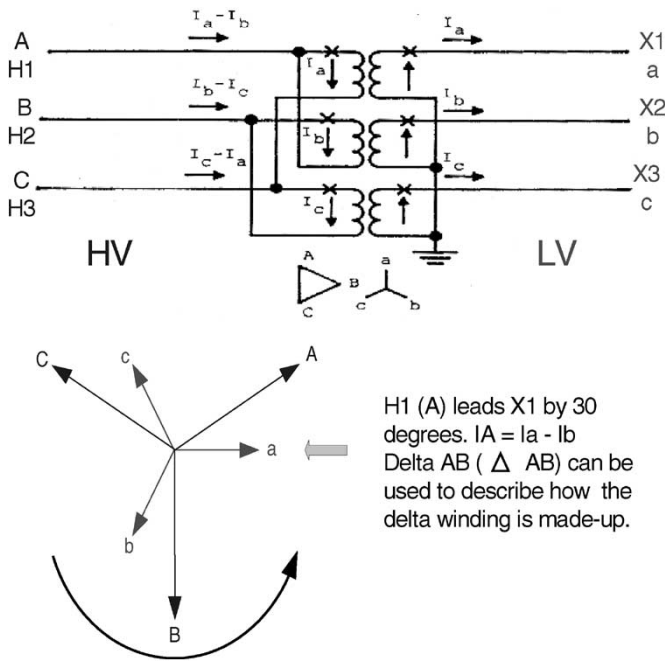

Fig. 5. IEEE/ANSI delta-ye transformer phasing.

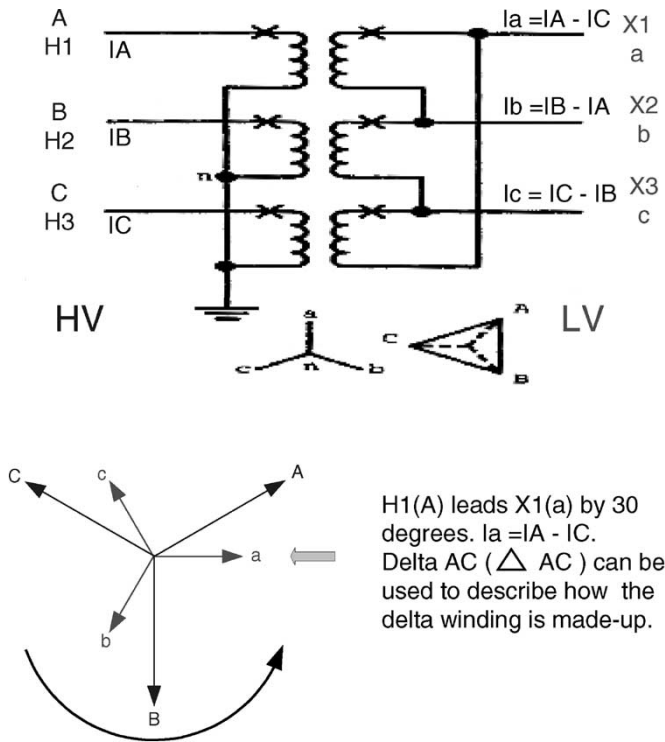

Fig. 6. IEEE/ANSI wye-delta transformer phasing.

30° increments that the phase angle is shifted (e.g., 1 = 30° and 11 = 11 × 30° = 330°). The letter D is used to designate a delta winding and the letter Y a wye winding. The letter that is capitalized is the primary or H winding of the transformer. Fig. 7 illustrates the clock concept and the standard IEC phasing examples.

To handle both of these phasing standards, relay manufacturers have used various techniques. Some have chosen to diagram

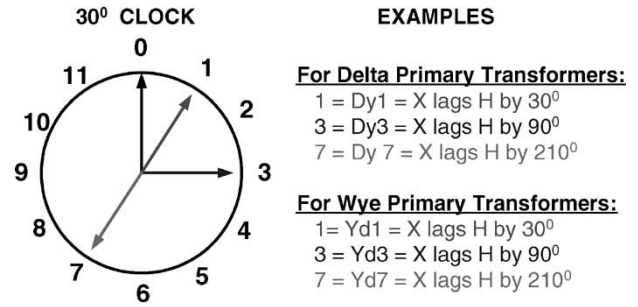

Fig. 7. IEC transformer phasing.

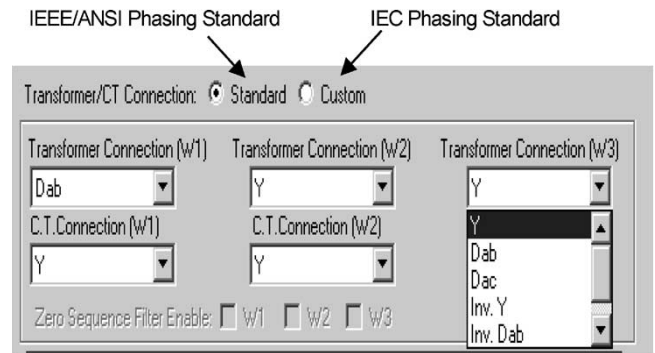

Fig. 8. Programmable phasing standard selection.

every possible transformer phasing connection, which results in over 250 three-line phasing diagrams. The number of specific cases is increased because of the fact that delta-connected current transformers (CTs) must be considered. Others have chosen to adopt the Euro clock, which can be used to describe IEEE/ANSI standard transformers as well as IEC transformers. One manufacturer has chosen to use the software to allow users to select either the IEEE/ANSI or the IEC standard.

This method allows North American users to define phase shift by the simple method of how the delta is configured on the A phase (Delta AB or Delta AC). If the relay is being used to protect an IEC standard transformer, a custom mode can be selected that uses the 30° clock described above. This results in a less complicated method to communicate transformer phase shift to a digital relay for standard IEEE/ANSI phasing application while still providing the flexibility to address IEC transformers. Fig. 8 illustrates this software.

### III. TRANSFORMER DIFFERENTIAL PROTECTION

Transformer differential protection is typically installed on transformers that are 10 MVA or larger [5]. At medium voltage industrial facilities where the transformer wye windings are grounded through a grounding resistor, smaller transformers are generally protected by differential relays due to the sensitivity issues described in Section II of this paper. Transformer differential protection is a challenge to apply because of factors such as current magnitude and phase angle balancing, inrush and overexcitation restraint, and CT performance. Digital relays have allowed manufacturers to improve many of the design elements that comprise transformer differential protection.

Transformer differential protection can be divided into two categories: phase and ground.

### A. Phase Differential (87T) Protection

Current magnitude balancing within a differential relay is accomplished through the selection of the appropriate transformer tap settings within the relay. The older technology of E-M relays used five or six discrete tap settings to balance current magnitudes on the primary and secondary of the transformer. They could balance a current mismatch of approximately 3 to 1. Digital relays have continuous settable tap settings and can balance a 10:1 current mismatch, making them more accurate and providing the flexibility to handle larger mismatches. Typically, the tap settings on the primary and secondary are selected by determining the full load current at the OA rating of the transformer and then checking to make sure the relay current coil ampere rating is not exceeded under emergency loading conditions.

Phase angle compensation is discussed fully in Section II of the paper. E-M transformer relays balance the phase angle externally through the connection of the input CTs. Wye transformer winding CT inputs are connected in delta, and delta winding CT inputs are connected in wye to balance the 30° phase shift. Frequently, when older transformers are upgraded with digital protection, it is easier to retain the delta CT wiring connections. The magnitude of the delta CT currents under normal balanced load conditions is 1.73 times higher than the individual line current for each of the CT phases being subtracted to form the delta—that is,  $I_a - I_c = 1.73I_a = 1.73I_c$ . Many digital relays do not compensate for the increase in current magnitude so that overcurrent relaying within the digital relay package being supplied from these same CTs must be compensated by setting the relays 1.73 times higher. Relay metering is also incorrectly displayed by the same value. This has been a source of confusion in some applications. There are, however, manufacturers that do compensate and provide overcurrent and metering with correct magnitude line currents.

Percentage restraint slope is a concept that is universally used in both E-M and digital relays to provide security against false operation during through-faults. It is recognized that the higher the through-fault current, the greater the possibility is that mismatch in CT performance will cause a false differential error current. In percentage restraint differential relays, the higher the through-fault current, the greater the value of differential current it takes to operate the relay. Fig. 9 illustrates this concept for a digital relay. The operating current ( $I_O$ ) is the vector sum of the primary and secondary per unit currents. Per unit current (pu) in differential relays is the CT current on the primary and secondary divided by the relay tap setting for that winding. The differential relay pickup must be set above steady state transformer magnetizing current and generally is set in the 0.2–0.3 pu range.

As shown in Fig. 9, the higher the through-fault current, the higher the value of the restraint current, which is the sum of the primary and secondary pu current magnitudes divided by two. Some relay designers use the larger of the two winding currents rather than the average of the two windings as the restraint cur-

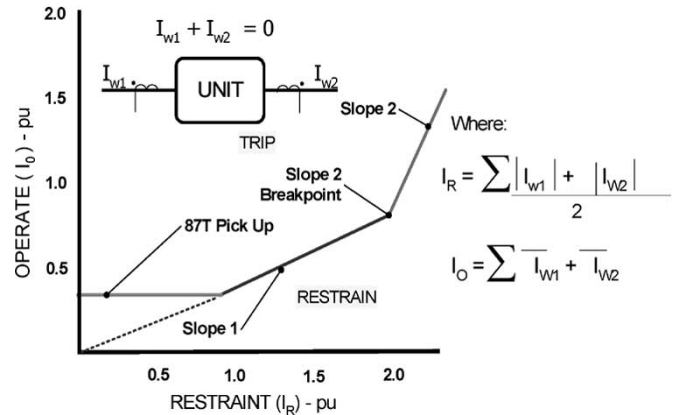

Fig. 9. Digital relay dual-slope characteristic.

rent. The higher the restraint current, the more operating current it takes to cause the differential unit to trip. Almost all digital transformer differential relays use the dual slope approach. At a settable breakpoint (usually at 2.0 pu restraint current), the slope is increased from slope 1 to slope 2. Slope 1 is set based on expected CT error (typically 10% for C class CTs), load tap-changing (LTC) tap range (usually 10%), magnetizing losses (about 1%), and a safety margin (about 5%). Thus, for a transformer without LTC, the slope 1 setting is typically 15–20%. For LTC transformers, the slope 1 setting is set higher to accommodate the ratio change with typical settings of 25–30%. The slope 2 setting is usually double the slope 1 setting. The quality of the CTs used to supply transformer differential relays generally requires that they operate in their linear range for worst-case symmetrical through-faults. A CT burden calculation can be done to verify linear operation. In addition, manufacturers generally provide specific guidance on minimum CT quality based on through-fault current levels.

Harmonic restraint is used within transformer differential relays to provide both inrush and overexcitation restraint. Inrush restraint is required when a transformer is energized. The transient magnetizing current to energize the transformer can be as high as 8–12 times the transformer rating. With high current in the primary winding and no current in the secondary windings, a high differential current will result. The transformer differential relay sees this unbalance as a trip condition.

The magnitude of inrush current depends on the residual magnetizing flux in the transformer core, the source impedance, and the point on the voltage wave when the circuit breaker contact closes. When the circuit breaker closes, all three phase contacts close at approximately the same time. The three phase voltages, however, are displaced from each other by 120°. Thus, two of the phase voltages will be near a maximum while one is near 0°. This imbalance in voltage results in inrush currents being unsymmetrical in each of the three phases. Inrush current is not entirely a 60-Hz sinusoidal current but comprised of a significant level of even harmonics with the most dominant being the second harmonic. For over 50 years, relay designers have used second harmonic restraint to prevent false differential operation on transformer energizing. Most digital relay designers also used second harmonic for inrush restraint. Digital relays are also designed so that the second harmonic

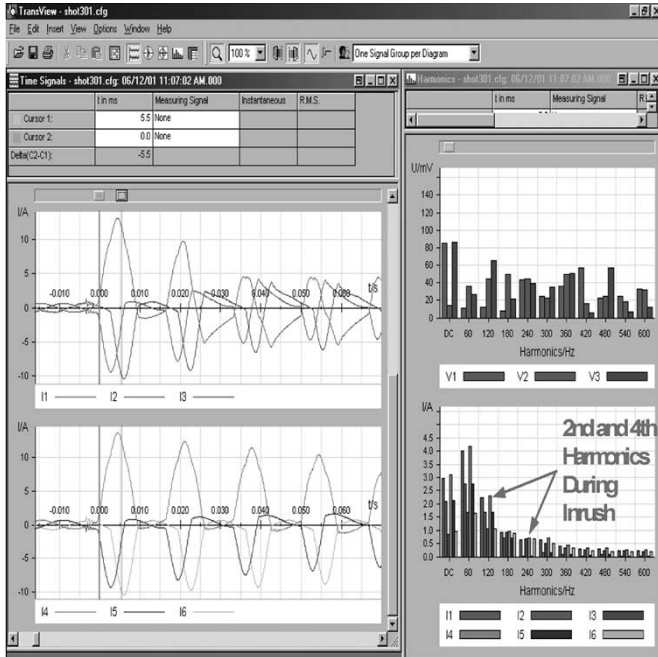

Fig. 10. Typical transformer inrush and harmonics.

in all three phases is combined in some manner to restrain the differential.

Today, newer transformers are being built with low-loss steel cores, which result in much less second harmonic current on energizing. This has caused differential relay tripping during energizing. At least one digital relay designer has reinforced the second harmonic restraint by also adding the fourth harmonic, which is typically around 40% of the second harmonic.

This design improved inrush restraint for low-loss steel core transformers. Fig. 10 shows inrush current for a typical transformer and the relative level of second and fourth harmonic content. Programming a digital relay with too low an inrush restraint setting risks the relay restraining for an internal fault because CT saturation can also produce significant levels of even harmonics. Transformer relays are equipped with a nonharmonically restrained high set differential element (87H) that provides protection for high current magnitude internal faults where CT saturation can occur. This element is set above expected inrush current.

Harmonic restraint is also used to prevent the transformer differential relay from operating during overexcitation events. Overexcitation occurs when the volts per hertz (V/Hz) level rises significantly, resulting in transformer saturation. Transformer core flux is proportional to voltage and inversely proportional to frequency. Overexcitation events can occur at an industrial facility during major system disturbances when industrial load is isolated from the utility system and is supplied from on-site generation. When a transformer is saturated, excitation current, which is normally very low, increases and unbalances the differential, causing it to operate.

Protection is required for overexcitation events, but the differential relay operation occurs so quickly that power system voltage control devices such as generator automatic voltage regulators (AVRs) are not given enough time to operate to correct

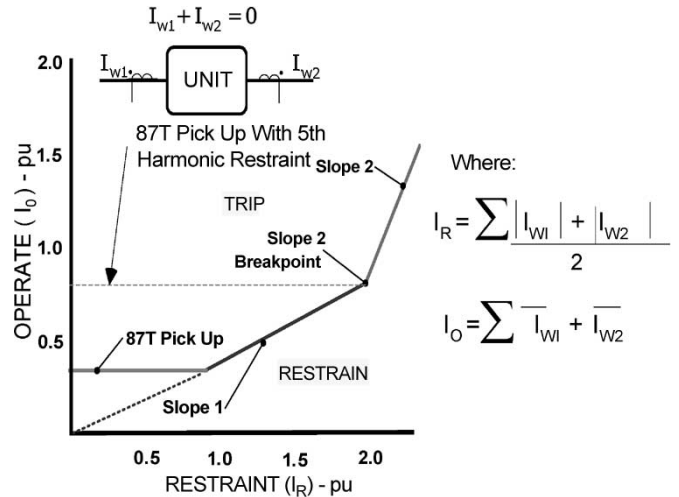

Fig. 11. Example of how 87T pick up is increased when significant fifth harmonic is present.

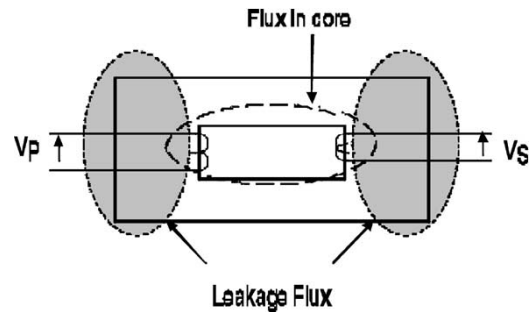

Fig. 12. Overexcitation transformer core flux.

the problem. When a transformer is overexcited, a significant amount of fifth harmonic current is generated. This harmonic is used to restrain the differential relay from operating. Most digital relay manufacturers block relay operation when the fifth harmonic exceeds a specific value—generally around 30%. Because the transformer is under stress during overexcitation, one manufacturer thought it more prudent to desensitize the relay rather than block its operation. This is done by raising the pickup when the fifth harmonic exceeds a specific value, which is settable in the relay. Fig. 11 illustrates how the relay slope is modified during overexcitation conditions.

Overexcitation of a transformer can damage the transformer if the event is allowed to persist. Overexcitation results in excessive core flux resulting in a high interlamination core voltage, which, in turn, results in iron burning. Also, at this high flux level, the normal magnetic iron path designed to carry flux saturates and flux begins to flow in leakage paths not designed to carry it, again causing damage. Fig. 12 illustrates this flux path.

The continuous overexcitation V/Hz transformer capability is specified in the IEEE C-57.12 [3] standard developed by the IEEE Transformer Committee. It specifies a 1.05 pu (on the transformer secondary base) at rated load and 0.8 PF or greater for loaded transformers. The short time capability varies based on transformer design.

Protection for overexcitation is provided by relay function (24) within a digital relay. This function measures the ratio of V/Hz. It is important that this function be implemented when

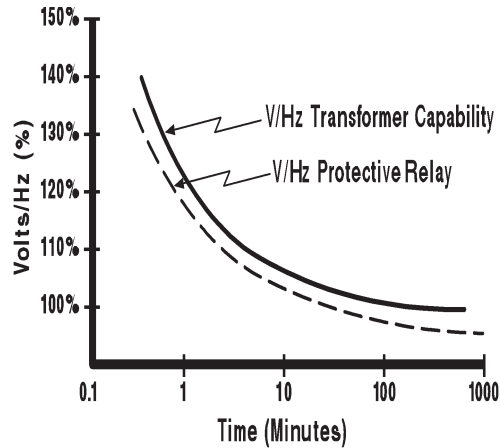

Fig. 13. Typical transformer V/Hz short-time capability.

protecting transformers with a digital package since digital relay differentials, unlike earlier E-M relays, are designed not to operate for an overexcitation event, thereby leaving the transformer unprotected. Whereas E-M relays provided only discrete time element V/Hz protection, digital relays offer an inverse time curve that closely matches most transformer overexcitation capability curves. This is illustrated in Fig. 13.

**B. Ground Differential (87GD) Protection**

Industrial transformers are generally grounded through a resistor in the transformer wye neutral as described above. Many industrial transformers rely solely on the phase differential (87T) to provide ground fault protection. Some relay engineers do not understand that phase differential protection alone does not provide the level of sensitivity to detect a ground fault over the entire wye winding. A significant portion of the wye winding near the neutral will not be protected if only phase differential is applied. Even for ground fault on the transformer wye terminal, additional sensitivity is required where ground fault current is limited to the 200–400-A level. Consider the following example shown in Fig. 14.

*Example:* Consider a 45-MVA 138/13.8 kVA transformer with 200/5 138-kVA CTs and a typical 87T relay pickup of 0.3 pu. Fig. 3 illustrates the current distribution for a delta–wye transformer ground fault. The relay tap is set at the 45-MVA transformer rating (Tap = 4.71 A secondary amps) and can only respond to a fault of 1.41 A (4.71 A × 0.3 = 1.41 A). The ground fault current (0.58 A) is below the threshold of operation of the 87T phase differential. Sensitive detection of secondary ground faults can be substantially increased through the addition of an 87GD ground differential relay, which uses a product approach, utilizing the following equation. The relay operating characteristic is

$$I_{OP} = (-3I_O)I_N \cos \Theta$$

where

- $I_{OP}$  relay operating current;
- $-3I_O$  residual current from the bus side CTs;
- $I_N$  transformer neutral current;
- $\Theta$  phase angle between the currents.

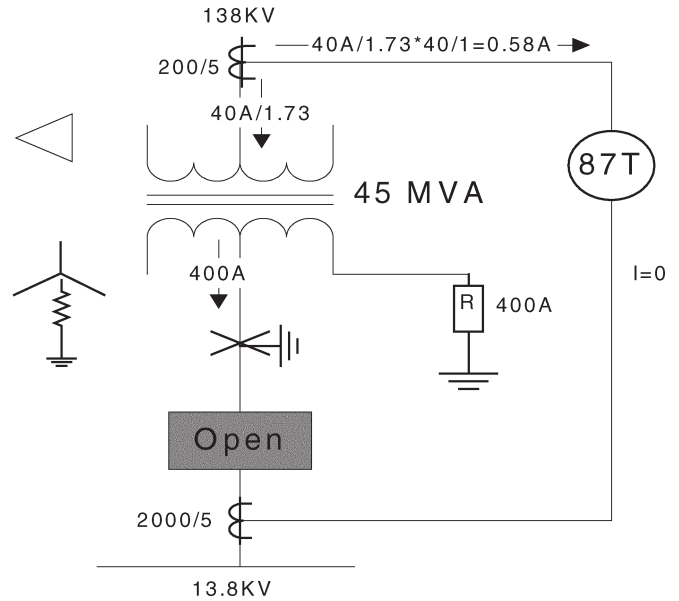

Fig. 14. Example of secondary ground fault.

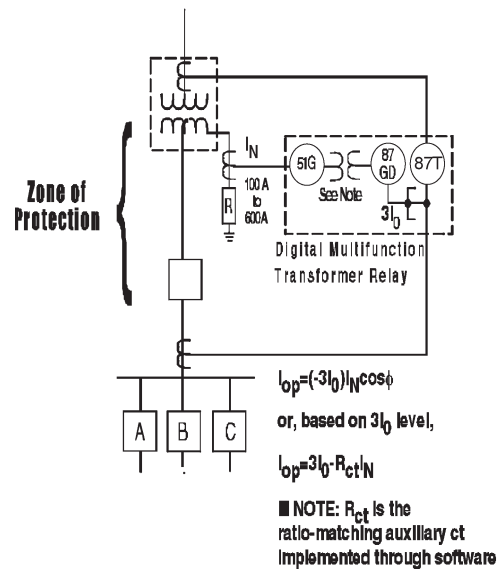

Fig. 15. Transformer digital ground differential relay.

The ground differential sensitivity is very high and will operate for an  $I_N$  current of 0.2 A. Fig. 15 illustrates the zone of operation where the 87T relay cannot detect ground faults. In many cases, the 51G neutral time overcurrent relay provides time delay protection for faults in this zone.

High-speed protection can be provided by use of a product-type ground differential relay described above. The concept was available in E-M technology and is now available in digital transformer protection packages. For faults external to the protective zone, the net operating quantity is negative and the relay will restrain from operating. For low values of  $3I_O$ , the relay automatically switches from a product to a balancing algorithm ( $3I_O - R_{ct}I_N$ ). This allows it to detect internal faults when the lowside transformer breaker is open as in Fig. 14.  $R_{ct}$  is a ratio matching auxiliary CT, which is provided as part of the software algorithm in digital relays as opposed to being

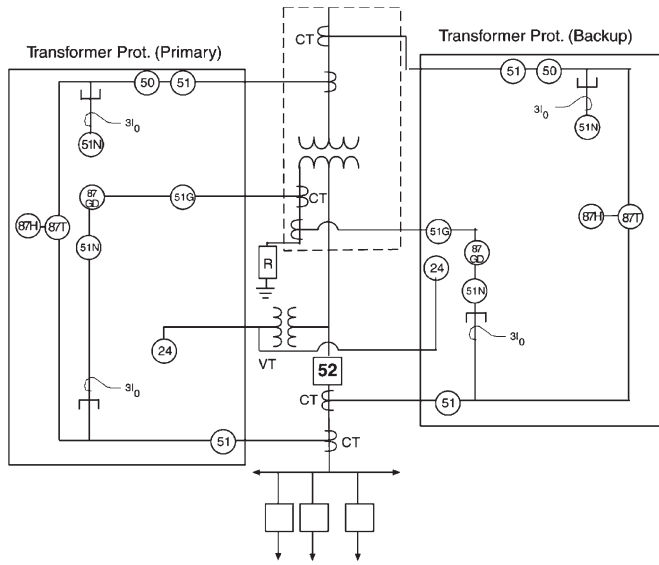

Fig. 16. Dual-relay transformer protection.

an actual CT as it was in E-M technology. This scheme provides excellent security against misoperations for external high-magnitude faults, even for cases where the phase CTs saturate. There are, however, some digital relay manufacturers that try to employ only a simple differential ( $I_N - 3I_O$ ). This method is prone to misoperate during high-magnitude through-faults. Transformer ground differential relaying substantially improves transformer ground fault sensitivity and is recommended in the Buff Book [4]. The example described above actually occurred at an industrial facility where the fault was caused by human error. High-speed protection for this event was extremely important and was provided by the digital ground differential that was recently installed on the transformer.

#### IV. APPLICATION AND COMMISSIONING OF DIGITAL TRANSFORMER RELAYS

Multifunction transformer digital relays have features that were not available on electromechanical or static relays. These include oscillography and event recording, multiple setting groups, multiple output and input contacts, metering, monitoring of external inputs/outputs, communications, self-monitoring and diagnostics, and programmable logic. These are the features that make digital relays the technology of choice for the protection of transformers. Many of these features also add to the complexity of setting and commissioning these relays.

The design of modern digital relays is such that all voltage and current inputs are multiplexed through common components. If a component fails, generally, all protective functions within the multifunction relay are inoperative. The relay engineer must be aware of this fact in deciding the level of redundancy for a particular application. For the protection of important generators or transformers, the effect on the system of removing these components from service for a relay failure may be unacceptable. In those cases, dual digital relays are used. A typical dual protection scheme for a transformer is shown in Fig. 16. Full input redundancy can be achieved by

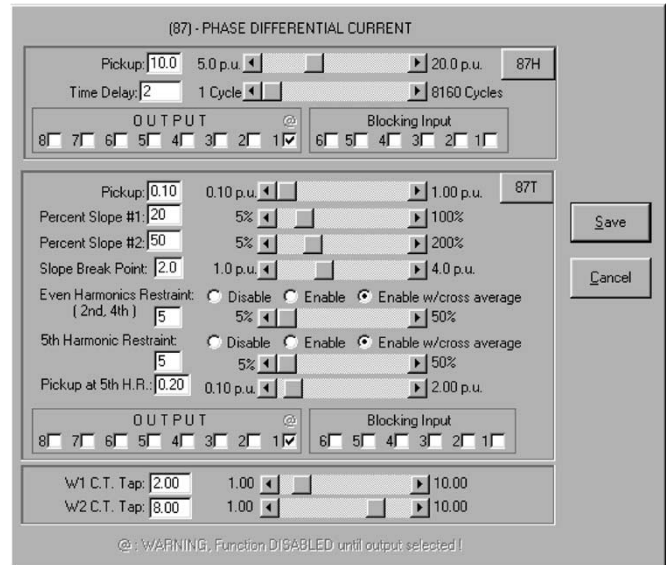

Fig. 17. Example: relay setting screen.

using separate CT and VT inputs for both primary and backup relays. Because of practical limitations, many users supply both primary and backup relays from the same CT and VT circuits. Using multiple digital output contacts to trip the high- and low-side breakers directly and also trip the lockout relay can provide output redundancy. This provides tripping even if the lockout relay fails. Also, some users reduce the functionality of the backup relay. An example of this is the use of overcurrent relaying as backup for transformer protection rather than fully redundant differential relaying as illustrated in Fig. 16.

#### A. Testing of Digital Relays

Testing multifunction digital transformer relays offers some unique challenges to the user. Multifunction relays have protective functions that interact with each other, making testing more complicated. They can also be programmed to do control logic, which must be verified. In addition, digital relays can have multiple setting groups that may be switched to address varying system conditions. This flexibility increases the commissioning complexity. These relays also have significant input monitoring capability that can greatly assist the user in determining whether these relays are properly connected to their CT and VT inputs, helping to verify that the relay is functioning properly.

Digital relays also have self-diagnostics that check the health of the relay that can immediately detect internal failures. This is perhaps the most important single feature in digital relays. The ability to detect a failure before the protection system has to operate contrasts with traditional protection where a failed or defective relay remains undetected until it does not operate correctly during a fault or until the next maintenance test. It is important that the thoroughness of self-diagnostics be considered in developing a maintenance/testing program for multifunction digital relays and that relay failure be alarmed to a manned location so that personnel can immediately take appropriate action.

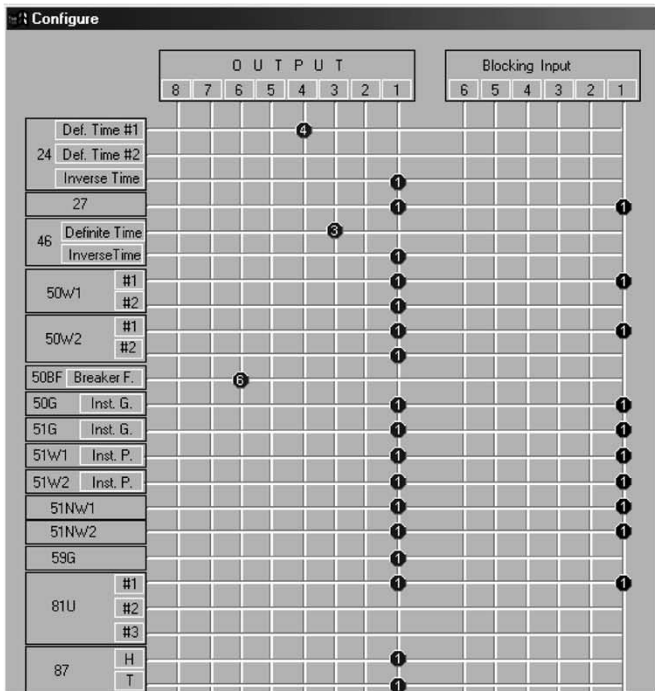

(a)

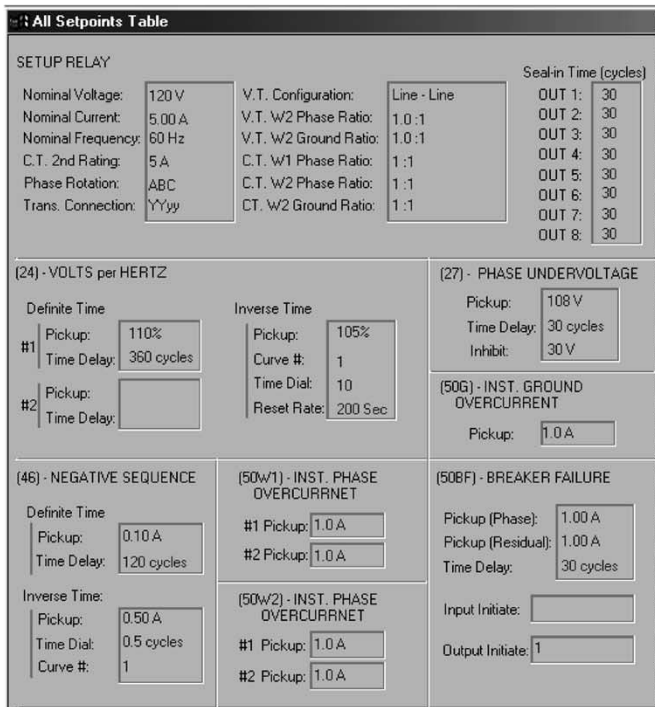

(b)

Fig. 18. (a) I/O assignment summary. (b) Setting summary.

**B. Commission Testing of Digital Relays**

Commission testing of digital transformer relays still requires the test engineer to verify the proper setting, internal logic, and operation for a new installation or verify a setting/logic/control change at an existing installation. This typically requires:

- 1) injection of current and voltage into the relay to verify relay setting and timing;

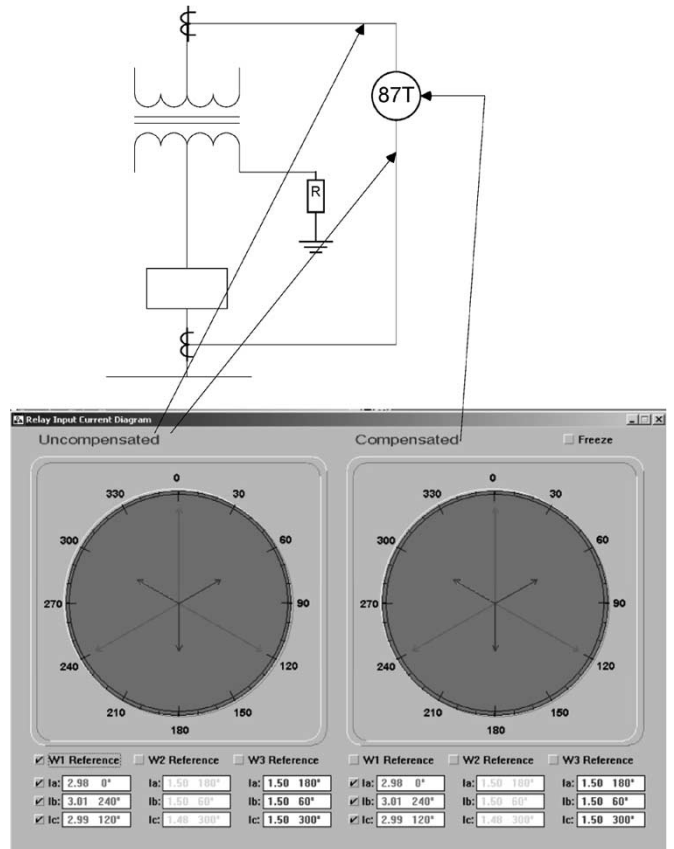

Fig. 19. Relay phase angle measurements.

- 2) verifying proper relay inputs and outputs;
- 3) verifying proper relay logic;
- 4) verifying tripping and targets.

Clearly, communicating settings to the relay is the first step in the field commissioning process. Simple and straightforward setting screens are important, and not all relay manufacturers provide setting screens that clearly show how the desired setting should be communicated to the relay. Section II of this paper discusses communication of the phase shift. Fig. 17 shows an example of a simple setting screen for the phase differential element. Problems in properly communicating the desired setting to the relay are a frequent source of errors.

Relay screens can also be used to provide valuable information to the field test engineer to confirm that the relay is connected to trip the proper outputs and all protective functions that have been specified to be in service are, in fact, programmed to be in service. These summary screens for both I/O assignments and setting functions are shown in Fig. 18(a) and (b). These screens are particularly important because during the injection testing processes, it is necessary to temporarily disable interfering functions to test the desired function. These screens provide positive feedback that all desired functions have been returned to service after testing.

The blank space for the 24 #2 set point in Fig. 18(b) indicates that this function is out of service. Determining that the phasing and current balancing of the phase differential 87T is correct is a major part of commissioning a digital transformer relay. Again, graphics in the relay can provide major help to

determine if the relay is wired correctly and that the settings are resulting in proper balancing of input and output currents. Fig. 19 illustrates “built-in” digital phase angle meters within the relay that look at both the input currents and the internally compensated currents. These meters provide positive indication that the relay is properly set and wired. If there is a problem, it will point to the commissioning engineer the root cause: wiring external to the relay or improper setting within the relay. This is a powerful commissioning tool that has proven its value in numerous installations.

The commissioning tools cited above are one of the major advantages of digital relays. The graphics used to communicate to the user are major differences between manufacturers with some doing a better job than others. Good well-thought-out graphics can reduce relay complexity, commissioning, and setting errors.

## V. CONCLUSION

Selecting, setting, and commissioning of new multifunction transformer digital relays offer unique challenges to the user. The advantages of numerous relay functions being available in a single hardware platform are offset to some extent by the need to provide for the failure of that platform. Also, it makes testing more difficult.

Digital relays reduce the external control wiring required by electromechanical and static relay technologies by incorporating control logic within the relay itself. This, however, results in more complex relay testing to verify proper relay control logic. These shortcomings, however, are far outweighed by the many advantages of digital relays cited in this paper. Users have also seen the many benefits of digital relays with almost all new installations using this technology.

## REFERENCES

- [1] Working Group 09 of CIGRE Study Committee 12, “Lifetime evaluation of transformers,” CIGRE, Paris, France, pp. 39–51, *Electra* 150, Oct. 1993.
- [2] W. H. Bartley, “Analysis of transformer failures,” presented at the Int. Association Engineering Insurers 36th Annu. Conf., Stockholm, Sweden, 2003, Paper IMIA WG 33.
- [3] *IEEE Standard General Requirements for Liquid-Immersed Distribution, Power and Regulating Transformers*. ANSI/IEEE Standard C57.12, 1993.
- [4] *IEEE Recommended Practices for the Protection and Coordination of Industrial and Commercial Power Systems*. ANSI/IEEE Standard 242-2001, 2001.
- [5] *IEEE Guide for Protective Relay Applications to Power Transformers*. ANSI/IEEE C37.91, 1985.



**Charles (Chuck) J. Mozina** (M'65) received the B.S. degree in electrical engineering from Purdue University, West Lafayette, IN, in 1965.

He has over 25 years of experience as a Protective Engineer at Centerior Energy, a major utility in Ohio, where he was Manager of System Protection. For ten years, he was an Application Manager for Protection Products with Beckwith Electric Company. He is a former Instructor at the Graduate School of Electrical Engineering, Cleveland State University.

He is currently a Consultant at Protection and Protection Systems, Beckwith Electric Company, Inc., North Largo, FL, specializing in power plant and generator protection. His consulting practice involves projects relating to protective relaying applications, protection system design, and coordination. He has authored a number of papers and magazine articles on protective relaying.

Mr. Mozina is an active 20-year Member of the IEEE Power System Relay Committee and was the past Chairman of the Rotating Machinery Subcommittee. He is active in the IEEE Industry Applications Society (IAS) Industrial and Commercial Power Systems (I&CPS) Committee, which addresses industrial protection systems. He is the past U.S. Representative to CIGRE Study Committee 34 on System Protection. He is a Registered Professional Engineer in the State of Ohio.