

**IEEE Standard for
Local and metropolitan area networks—**

**Part 15.4: Low-Rate Wireless Personal Area
Networks (LR-WPANs)**

**Amendment 3: Physical Layer (PHY) Specifications for Low-
Data-Rate, Wireless, Smart Metering Utility Networks**

IEEE Computer Society

Sponsored by the
LAN/MAN Standards Committee

IEEE
3 Park Avenue
New York, NY 10016-5997
USA

IEEE Std 802.15.4g™-2012
(Amendment to
IEEE Std 802.15.4™-2011)

27 April 2012

**IEEE Standard for
Local and metropolitan area networks—**

**Part 15.4: Low-Rate Wireless Personal Area
Networks (LR-WPANs)**

**Amendment 3: Physical Layer (PHY) Specifications for Low-
Data-Rate, Wireless, Smart Metering Utility Networks**

Sponsor

**LAN/MAN Standards Committee
of the
IEEE Computer Society**

Approved 29 March 2012

IEEE-SA Standards Board

Abstract: In this amendment to IEEE Std 802.15.4-2011, outdoor low-data-rate, wireless, smart metering utility network requirements are addressed. Alternate PHYs are defined as well as only those MAC modifications needed to support their implementation.

Keywords: ad hoc network, IEEE 802.15.4, IEEE 802.15.4g, low data rate, low power, LR-WPAN, mobility, PAN, personal area network, radio frequency, RF, short range, smart metering utility networks, SUN, wireless, wireless personal area network, WPAN

The Institute of Electrical and Electronics Engineers, Inc.
3 Park Avenue, New York, NY 10016-5997, USA

Copyright © 2012 by The Institute of Electrical and Electronics Engineers, Inc.
All rights reserved. Published 27 April 2012. Printed in the United States of America.

IEEE is a registered trademark in the U.S. Patent & Trademark Office, owned by The Institute of Electrical and Electronics Engineers, Incorporated.

Print: ISBN 978-0-7381-7259-0 STD97234
PDF: ISBN 978-0-7381-7365-8 STDPD97234

IEEE prohibits discrimination, harassment, and bullying. For more information, visit <http://www.ieee.org/web/aboutus/whatis/policies/p9-26.html>.

No part of this publication may be reproduced in any form, in an electronic retrieval system or otherwise, without the prior written permission of the publisher.

Notice and Disclaimer of Liability Concerning the Use of IEEE Documents: IEEE Standards documents are developed within the IEEE Societies and the Standards Coordinating Committees of the IEEE Standards Association (IEEE-SA) Standards Board. IEEE develops its standards through a consensus development process, approved by the American National Standards Institute, which brings together volunteers representing varied viewpoints and interests to achieve the final product. Volunteers are not necessarily members of the Institute and serve without compensation. While IEEE administers the process and establishes rules to promote fairness in the consensus development process, IEEE does not independently evaluate, test, or verify the accuracy of any of the information or the soundness of any judgments contained in its standards.

Use of an IEEE Standard is wholly voluntary. IEEE disclaims liability for any personal injury, property or other damage, of any nature whatsoever, whether special, indirect, consequential, or compensatory, directly or indirectly resulting from the publication, use of, or reliance upon any IEEE Standard document.

IEEE does not warrant or represent the accuracy or content of the material contained in its standards, and expressly disclaims any express or implied warranty, including any implied warranty of merchantability or fitness for a specific purpose, or that the use of the material contained in its standards is free from patent infringement. IEEE Standards documents are supplied "AS IS."

The existence of an IEEE Standard does not imply that there are no other ways to produce, test, measure, purchase, market, or provide other goods and services related to the scope of the IEEE standard. Furthermore, the viewpoint expressed at the time a standard is approved and issued is subject to change brought about through developments in the state of the art and comments received from users of the standard. Every IEEE standard is subjected to review at least every ten years. When a document is more than ten years old and has not undergone a revision process, it is reasonable to conclude that its contents, although still of some value, do not wholly reflect the present state of the art. Users are cautioned to check to determine that they have the latest edition of any IEEE standard.

In publishing and making its standards available, IEEE is not suggesting or rendering professional or other services for, or on behalf of, any person or entity. Nor is IEEE undertaking to perform any duty owed by any other person or entity to another. Any person utilizing any IEEE Standards document, should rely upon his or her own independent judgment in the exercise of reasonable care in any given circumstances or, as appropriate, seek the advice of a competent professional in determining the appropriateness of a given IEEE standard.

Translations: The IEEE consensus development process involves the review of documents in English only. In the event that an IEEE standard is translated, only the English version published by IEEE should be considered the approved IEEE standard.

Official Statements: A statement, written or oral, that is not processed in accordance with the IEEE-SA Standards Board Operations Manual shall not be considered the official position of IEEE or any of its committees and shall not be considered to be, nor be relied upon as, a formal position of IEEE. At lectures, symposia, seminars, or educational courses, an individual presenting information on IEEE standards shall make it clear that his or her views should be considered the personal views of that individual rather than the formal position of IEEE.

Comments on Standards: Comments for revision of IEEE Standards documents are welcome from any interested party, regardless of membership affiliation with IEEE. However, IEEE does not provide consulting information or advice pertaining to IEEE Standards documents. Suggestions for changes in documents should be in the form of a proposed change of text, together with appropriate supporting comments. Since IEEE standards represent a consensus of concerned interests, it is important to ensure that any responses to comments and questions also receive the concurrence of a balance of interests. For this reason, IEEE and the members of its societies and Standards Coordinating Committees are not able to provide an instant response to comments or questions except in those cases where the matter has previously been addressed. Any person who would like to participate in evaluating comments or revisions to an IEEE standard is welcome to join the relevant IEEE working group at <http://standards.ieee.org/develop/wg/>.

Comments on standards should be submitted to the following address:

Secretary, IEEE-SA Standards Board
445 Hoes Lane
Piscataway, NJ 08854-4141
USA

Photocopies: Authorization to photocopy portions of any individual standard for internal or personal use is granted by The Institute of Electrical and Electronics Engineers, Inc., provided that the appropriate fee is paid to Copyright Clearance Center. To arrange for payment of licensing fee, please contact Copyright Clearance Center, Customer Service, 222 Rosewood Drive, Danvers, MA 01923 USA; +1 978 750 8400. Permission to photocopy portions of any individual standard for educational classroom use can also be obtained through the Copyright Clearance Center.

Notice to users

Laws and regulations

Users of IEEE Standards documents should consult all applicable laws and regulations. Compliance with the provisions of any IEEE Standards document does not imply compliance to any applicable regulatory requirements. Implementers of the standard are responsible for observing or referring to the applicable regulatory requirements. IEEE does not, by the publication of its standards, intend to urge action that is not in compliance with applicable laws, and these documents may not be construed as doing so.

Copyrights

This document is copyrighted by the IEEE. It is made available for a wide variety of both public and private uses. These include both use, by reference, in laws and regulations, and use in private self-regulation, standardization, and the promotion of engineering practices and methods. By making this document available for use and adoption by public authorities and private users, the IEEE does not waive any rights in copyright to this document.

Updating of IEEE documents

Users of IEEE Standards documents should be aware that these documents may be superseded at any time by the issuance of new editions or may be amended from time to time through the issuance of amendments, corrigenda, or errata. An official IEEE document at any point in time consists of the current edition of the document together with any amendments, corrigenda, or errata then in effect. In order to determine whether a given document is the current edition and whether it has been amended through the issuance of amendments, corrigenda, or errata, visit the [IEEE-SA Website](#) or contact the IEEE at the address listed previously. For more information about the IEEE Standards Association or the IEEE standards development process, visit the [IEEE-SA Website](#).

Errata

Errata, if any, for this and all other standards can be accessed at the following URL: <http://standards.ieee.org/findstds/errata/index.html>. Users are encouraged to check this URL for errata periodically.

Patents

Attention is called to the possibility that implementation of this standard may require use of subject matter covered by patent rights. By publication of this standard, no position is taken by the IEEE with respect to the existence or validity of any patent rights in connection therewith. If a patent holder or patent applicant has filed a statement of assurance via an Accepted Letter of Assurance, then the statement is listed on the IEEE-SA Website at <http://standards.ieee.org/about/sasb/patcom/patents.html>. Letters of Assurance may indicate whether the Submitter is willing or unwilling to grant licenses under patent rights without compensation or under reasonable rates, with reasonable terms and conditions that are demonstrably free of any unfair discrimination to applicants desiring to obtain such licenses.

Essential Patent Claims may exist for which a Letter of Assurance has not been received. The IEEE is not responsible for identifying Essential Patent Claims for which a license may be required, for conducting inquiries into the legal validity or scope of Patents Claims, or determining whether any licensing terms or conditions provided in connection with submission of a Letter of Assurance, if any, or in any licensing agreements are reasonable or non-discriminatory. Users of this standard are expressly advised that determination of the validity of any patent rights, and the risk of infringement of such rights, is entirely their own responsibility. Further information may be obtained from the IEEE Standards Association.

Participants

At the time the draft of this standard was sent to sponsor ballot, the IEEE P802.15 Working Group had the following voting members:

Robert F. Heile, *Chair*
Rick Alfvén, *Vice Chair*
Patrick W. Kinney, *Vice Chair, Secretary*
James P. K. Gilb, *Technical Editor*
Clint Chaplin, *Treasurer*

Philip E. Beecher, *Task Group 4g Chair*
Hiroshi Harada, *Task Group 4g Co-vice Chair*
Clinton C. Powell, *Task Group 4g Co-vice Chair*
Monique B. Brown, *Task Group 4g Co-editor*
Kuor-Hsin Chang, *Task Group 4g Co-editor*
Stephen P. Pope, *Task Group 4g Secretary*
Jana van Greunen, *Task Group 4g Secretary (past)*

Chin-Sean Sum, *Coexistence Assurance Contributing Editor*
Alina Liru Lu, *Task Group 4g Assistant Secretary*
Benjamin A. Rolfe, *Task Group 4g Assistant Secretary*
Kunal Shah, *Task Group 4g Assistant Secretary*

Emad Affi
Gahng-Seop Ahn
Roberto Aiello
Arthur Astrin
Taehan Bae
Michael Bahr
John Barr
Anuj Batra
Tuncer Baykas
Ashutosh Bhatia
Ghulam Bhatti
Gary Birk
Mathew Boytim
Peter David Bradley
Nancy Bravin
David Britz
Sverre Brubk
Brian Buchanan
John Buffington
Kiran Bynam
Brent Cain
Edgar H. Callaway
Chris Calvert
Ruben Cardozo
Douglas Castor
Jaesang Cha
Russell Chandler
Soo-Young Chang
Clint Chaplin
Hind Chebbo
Chang-Soon Choi
Sangsung Choi
Ciaran Connell
David Cypher
Matthew Dahl
David Davenport

Mark Dawkins
Hendricus De Ruijter
Upkar Dhaliwal
Gang Ding
Paul Dixon
Guido Dolmans
Igor Dotlic
Michael Dow
Dietmar Eggert
David Evans
Charles Farlow
John Farserotu
Jeffrey Fischbeck
Mike Fischer
George Flammer
Ryosuke Fujiwara
Noriyasu Fukatsu
Kiyoshi Fukui
John Geiger
Gregory Gillooly
Tim Godfrey
Paul Gorday
Elad Gottlib
Robert Hall
Shinsuke Hara
Timothy Harrington
Rodney Hemminger
Marco Hernandez
Garth Hillman
Jin-Meng Ho
Wei Hong
Srinath Hosur
David A. Howard
Jung-Hwan Hwang
Taeho Hwang
Ichirou Ida

Tetsushi Ikegami
Akio Iso
Yeong Min Jang
Adrian Jennings
Wuncheol Jeong
Steven Jillings
Noh-Gyoung Kang
Tae-Gyu Kang
Shuzo Kato
Tatsuya Kato
Jeritt Kent
Prithpal Khakuria
Dae Ho Kim
Dong-Sun Kim
Dukhyun Kim
Jaehwan Kim
Jeffrey King
Ryuji Kohno
Fumihide Kojima
Bruce Kraemer
Raymond Krasinski
Masahiro Kuroda
John Lampe
Zhou Lan
Khanh Le
Cheolhyo Lee
Hyungsoo Lee
Myung Lee
Daniel Lewis
Huan-Bang Li
Liang Li
Sang-Kyu Lim
Jeremy Link
Mike Lynch
Robert Mason
Tomokuni Matsumura

Jeff McCullough
Michael McGillan
Michael D. McInnis
Michael McLaughlin
Charles Millet
Siamak Mirnezami
Rishi Mohindra
Emmanuel Monnerie
Rajendra Moorti
Robert Moskowitz
Hamilton Moy
Peter Murray
Theodore Myers
Chiu Ngo
Paul Nikolich
Hirohito Nishiyama
David Olson
Okundu Omeni
Ryoji Ono
Laurent Ouvry
James Pace
Hyung-Il Park
Jahng Park
Seung-Hoon Park
Taejoon Park
Ranjeet Patro
Al Petrick
Dalibor Pokrajac
Daniel Popa
Richard Powell
Chang-Woo Pyo
Mohammad Rahman

Sridhar Rajagopal
Jayaram Ramasastry
Marc Reed
Ivan Reede
Richard Roberts
Craig Rodine
June Chul Roh
Seung-Moon Ryu
Didier Sagan
Kentaro Sakamoto
Will San Filippo
H. Sanderford
Kamran Sayrafian
Timothy Schmid
Michael Schmidt
Jean Schwoerer
Cristina Seibert
Neal Seidl
Steve Shearer
Stephen Shellhammer
Shusaku Shimada
Chang Sub Shin
Cheol Ho Shin
Michael Sim
Jonathan Simon
Jaeseung Son
Paul Stadnik
René Struik
Hui-Hsia Sung
Gu Sungi
Kenichi Takizawa
Hirokazu Tanaka

Larry Taylor
Mark Thompson
James Tomeik
Ichihiko Toyoda
David Tracey
Khanh Tran
Jerry Upton
Hartman van Wyk
Michel Veillette
Billy Verso
Bhupender Virk
Joachim Walewski
Junyi Wang
Quan Wang
Xiang Wang
Andy Ward
Scott Weikel
Nicholas West
Mark Wilbur
Ludwig Winkel
Eun Tae Won
Alan Chi Wai Wong
Tao Xing
Wen-Bin Yang
Yang Yang
Kazuyuki Yasukawa
Kamyaz Yazdandoost
Kaoru Yokoo
Mu Zhao
Bin Zhen

Major contributions were received from the following individuals:

Roberto Aiello
Matt Boytim
Sverre Brubak
John Buffington
Edgar H. Callaway
Sangsung Choi
Hendricus De Ruijter
Dietmar Eggert
George Flammer
James P. K. Gilb
Elad Gottlib
Rodney C. Hemminger
David A. Howard
Steven Jillings
Seong-Soon Joo
Jeritt Kent

Jeffrey King
Fumihide Kojima
John Lampe
Khanh Tuan Le
Liang Li
Robert Mason
Charles Millet
Emmanuel Monnerie
Tae-Joon Park
Gilles Picard
Frank Poegel
Daniel Popa
Jayaram Ramasastry
Kentaro Sakamoto
Ruben Salazar

Britton Sanderford
Timothy M. Schmidl
Michael Schmidt
Cristina Seibert
Steve Shearer
Jie Shen
Cheolho Shin
Larry Taylor
Khurram Waheed
Xiang Wang
Scott Weikel
Mark Wilbur
Hartman van Wyk
Kazuyuki Yasukawa
Zhen Feng Zhao

The following members of the balloting committee voted on this standard. Balloters may have voted for approval, disapproval, or abstention.

Jon Adams	Marco Hernandez	John Notor
Emad Afifi	Ryoichi Higashi	Satoshi Obara
Roberto Aiello	Srinath Hosur	Masayuki Oodo
Rick Alfvn	David A. Howard	Chris Osterloh
Nobumitsu Amachi	Heqing Huang	Satoshi Oyama
Patrick Amihood	David Hunter	Frank Poegel
Butch Anton	Ichirou Ida	Dalibor Pokrajac
Takamasa Asano	Tetsushi Ikegami	Daniel Popa
Arthur Astrin	Noriyuki Ikeuchi	Clinton C. Powell
Stefan Aust	Akio Iso	Venkatesha Prasad
Michael Bahr	Atsushi Ito	Mohammad Rahman
Jonathan Bailey	Raj Jain	Jayaram Ramasastry
Jay Bain	Oyvind Janbu	Mark Ranta
Takahiro Banno	Junghoon Jee	Charles Razzell
Edward Baranski	Jorjeta Jetcheva	Maximilian Riegel
Anuj Batra	Steven Jillings	Robert Robinson
Philip E. Beecher	Tal Kaitz	Craig Rodine
Harry Bims	Shinkyoo Kaku	Benjamin A. Rolfe
Mathew Boytim	Aiichiro Kashiwagi	Carl Royer
Nancy Bravin	Takuya Kawata	Randall Safier
Vern Brethour	Ruediger Kays	Tatsuhiko Sakai
Monique B. Brown	Raymond H. Kelley	Kentaro Sakamoto
John Buffington	Jeritt Kent	Kazuyuki Sakoda
William Byrd	Stuart J. Kerry	H. Sanderford
Brent Cain	Brian Kiernan	Shigenobu Sasaki
Edgar H. Callaway	Il Han Kim	Katsuyoshi Sato
Radhakrishna Canchi	Yongbum Kim	Naotaka Sato
Dave Cavalcanti	Jeffrey King	Bartien Sayogo
Kuor-Hsin Chang	Patrick W. Kinney	Timothy M. Schmidl
Clint Chaplin	Fumihide Kojima	Michael Schmidt
Ger-Chih Chou	Bruce Kraemer	Cristina Seibert
Keith Chow	Yasushi Kudoh	Kunal Shah
Charles Cook	Geoff Ladwig	Durgaprasad Shamain
Michael Coop	Zhou Lan	Donald Shaver
Joseph Decuir	Khanh Tuan Le	Steve Shearer
Patrick Diamond	Jan-Ray Liao	Jie Shen
Thomas Dineen	Arthur Light	Shusaku Shimada
Sourav Dutta	HaiTao Liu	John Short
Peter Ecclesine	Alina Liru Lu	Gil Shultz
Richard Edgar	Daniel Lubar	Jonathan Simon
Stanislav Filin	William Lumpkins	Amjad Soomro
Will San Filippo	Greg Luri	Thomas Starai
George Flammer	Mike Lynch	René Struik
Kimberly Francisco	Elvis Maculuba	Walter Struppler
Avraham Freedman	Stephen Makgill	Mark Sturza
Kiyoshi Fukui	Robert Mason	Chin-Sean Sum
Keisuke Fukushima	Jeff McCullough	Chen Sun
John Geiger	Michael McGillan	YanJun Sun
James P. K. Gilb	Michael D. McInnis	Takahisa Tai
Gregory Gillooly	Michael McLaughlin	Jun Ichi Takada
Tim Godfrey	Gary Michel	Yoichi Tanaka
Elad Gottlib	Charles Millet	Larry Taylor
Randall Groves	Paul Mobus	Ha Nguyen Tran
Michael Gundlach	Apurva Mody	Mark-Rene Uchida
Henrik Gustafsson	Emmanuel Monnerie	Anna Urra
Jose Gutierrez	Jose Morales	David Uy
C. Guy	Kenichi Mori	Jana van Greunen
Rainer Hach	Peter Murray	Dmitri Varsanofiev
Christopher Hansen	Nabil Nasser	Prabodh Varshney
Hiroshi Harada	Michael S. Newman	John Vergis
Satoshi Hasako	Paul Nikolich	Dalton Victor

Bhupender Virk
Jerome Viviano
George Vlantis
Khurram Waheed
Junyi Wang
Stanley Wang
Xiang Wang

Deric Waters
Hung-Yu Wei
Scott Weikel
Mark Wilbur
Ludwig Winkel
Andreas Wolf
Ariton Xhafa

Tao Xing
Yang Yang
Masahiro Yasui
Kazuyuki Yasukawa
Tan Pek Yew
Jianming Yuan
Oren Yuen

When the IEEE-SA Standards Board approved this standard on 29 March 2012, it had the following membership:

Richard H. Hulett, *Chair*
John Kulick, *Vice Chair*
Robert Grow, *Past Chair*
Judith Gorman, *Secretary*

Satish Aggarwal
Masayuki Ariyoshi
Peter Balma
William Bartley
Ted Burse
Clint Chaplin
Wael Diab
Jean-Philippe Faure

Alexander Gelman
Paul Houzé
Jim Hughes
Young Kyun Kim
Joseph L. Koepfinger*
David J. Law
Thomas Lee
Hung Ling

Oleg Logvinov
Ted Olsen
Gary Robinson
Jon Walter Rosdahl
Mike Seavey
Yatin Trivedi
Phil Winston
Yu Yuan

*Member Emeritus

Also included are the following nonvoting IEEE-SA Standards Board liaisons:

Richard DeBlasio, *DOE Representative*
Michael Janezic, *NIST Representative*

Michelle Turner
IEEE Standards Program Manager, Document Development

Patricia A. Gerdon
IEEE Standards Program Manager, Technical Program Development

Introduction

This introduction is not part of IEEE Std 802.15.4g-2012, IEEE Standard for Local and metropolitan area networks—Part 15.4: Low-Rate Wireless Personal Area Networks (LR-WPANs)—Amendment 3: Physical Layer Specifications for Low Data Rate Wireless Smart Metering Utility Networks.

This amendment specifies alternate PHYs in addition to those of IEEE Std 802.15.4-2011. In addition to the new PHYs, the amendment also defines those MAC modifications needed to support their implementation.

The alternate PHYs support principally outdoor, low-data-rate, wireless, smart metering utility network (SUN) applications under multiple regulatory domains. The SUN PHYs are as follows:

- Multi-rate and multi-regional frequency shift keying (MR-FSK) PHY
- Multi-rate and multi-regional orthogonal frequency division multiplexing (MR-OFDM) PHY
- Multi-rate and multi-regional offset quadrature phase-shift keying (MR-O-QPSK) PHY

The SUN PHYs support multiple data rates in bands ranging from 169 MHz to 2450 MHz.

Contents

2. Normative references	2
3. Definitions, acronyms, and abbreviations	3
3.1 Definitions	3
3.2 Acronyms and abbreviations	3
4. General description	5
4.1a Introduction to smart metering utility network (SUN)	5
4.2a MR-FSK Generic PHY mechanism	5
4.2b Mode switch mechanism	5
4.2c Multi-PHY management (MPM) of the SUN WPAN	6
5. MAC protocol	7
5.1 MAC functional description	7
5.1.1 Channel access	7
5.1.2 Starting and maintaining PANs	9
5.1.6 Transmission, reception, and acknowledgment	9
5.1.13 MPM procedure for inter-PHY coexistence	9
5.2 MAC frame formats	12
5.2.1 General MAC frame format	12
5.2.2 Format of individual frame types	14
5.2.4 Information element	16
6. MAC services	24
6.2 MAC management service	24
6.2.4 Communications notification primitives	24
6.2.10 Primitives for channel scanning	24
6.2.12 Primitives for updating the superframe configuration	24
6.3 MAC data service	26
6.3.1 MCPS-DATA.request	26
6.3.3 MCPS-DATA.indication	28
6.4 MAC constants and PIB attributes	28
6.4.1 MAC constants	28
6.4.2 MAC PIB attributes	29
6.4.3 Calculating PHY dependent MAC PIB values	30
8. General PHY requirements	31
8.1 General requirements and definitions	31
8.1.1 Operating frequency range	31
8.1.2 Channel assignments	33
8.1.3 Minimum LIFS and SIFS periods	41
8.1.7 Receiver sensitivity definitions	41
8.1a Common signaling mode (CSM) for SUN PHY	41
8.2 General radio specifications	42
8.2.7 Clear channel assessment (CCA)	42
9. PHY services	43
9.2 PHY constants	43

9.3	PHY PIB attributes	43
9.4	PHY PIB attribute values for phyMaxFrameDuration and phySHRDuration	48
18.	SUN PHYs	50
18.1	MR-FSK PHY specification	50
18.1.1	PPDU format for MR-FSK	50
18.1.2	Modulation and coding for MR-FSK	54
18.1.3	Data whitening for MR-FSK	64
18.1.4	Mode switch mechanism for MR-FSK	65
18.1.5	MR-FSK PHY RF requirements	67
18.2	MR-OFDM PHY specification	70
18.2.1	PPDU format for MR-OFDM	70
18.2.2	Data rates for MR-OFDM	79
18.2.3	Modulation and coding for MR-OFDM	81
18.2.4	MR-OFDM PHY RF requirements	91
18.3	MR-O-QPSK PHY specification	95
18.3.1	PPDU format for MR-O-QPSK	95
18.3.2	Modulation and coding for MR-O-QPSK	98
18.3.3	Support of legacy devices of the 780 MHz, 915 MHz, and 2450 MHz O-QPSK PHYs	119
18.3.4	MR-O-QPSK PHY RF requirements	120
Annex A	(informative) Bibliography	124
Annex D	(informative) Protocol implementation conformance statement (PICS) proforma	125
D.2	Abbreviations and special symbols	125
D.7	PICS proforma tables	125
D.7.1	Functional device types	125
D.7.2	Major capabilities for the PHY	126
D.7.3	Major capabilities for the MAC sublayer	128
Annex K	(informative) Example usage of MR-FSK Generic PHY mechanism	129
K.1	Introduction	129
K.2	Example of SUN channel page usage for a device supporting MR-FSK Generic PHY modes	129
K.3	Example of SUN channel page usage for a device supporting both standard-defined and MR-FSK Generic PHY modes1	130
Annex L	(informative) Example of encoding a packet for MR-OFDM PHY when PIB attribute phyOFDMInterleaving is zero	131
L.1	Introduction	131
L.2	The message	131
L.3	Generation of the OFDM header	133
L.3.1	HCS and PAD bits insertion	133
L.3.2	Convolutional encoding	133
L.3.3	Interleaving	134
L.3.4	Bit mapping	135
L.3.5	Frequency spreading	136
L.4	Generation of the data symbols137	137
L.4.1	PAD insertion and data scrambling	137

L.4.2	Convolutional encoding and puncturing	138
L.4.3	Interleaving	138
L.4.4	Bit mapping	140
L.4.5	Frequency spreading.....	142
L.5	Conversion from frequency domain to time domain	142
L.5.1	Pilot, DC, and guard tone insertion	142
L.5.2	Time domain OFDM header and payload	144
L.6	Generation of the preamble.....	145
L.6.1	Generation of the STF	145
L.6.2	Generation of the LTF	145
L.7	The entire packet	147
Annex M (informative)	Example of encoding a packet for MR-OFDM PHY when PIB attribute phyOFDMInterleaving is one	161
M.1	Introduction	161
M.2	The message	161
M.3	Generation of the OFDM header.....	161
M.3.1	HCS and PAD bits insertion	161
M.3.2	Convolutional encoding	161
M.3.3	Interleaving	163
M.3.4	Bit mapping.....	165
M.3.5	Frequency spreading	165
M.4	Generation of the data symbols.....	167
M.4.1	PAD insertion and data scrambling.....	167
M.4.2	Convolutional encoding and puncturing	168
M.4.3	Interleaving.....	169
M.4.4	Bit mapping	170
M.4.5	Frequency spreading.....	172
M.5	Conversion from frequency domain to time domain	172
M.5.1	Pilot, DC, and guard tone insertion	172
M.5.2	Time domain OFDM header and payload	172
M.6	The entire packet.....	175
Annex N (informative)	Example of encoding a packet for MR-O-QPSK PHY.....	202
N.1	Introduction.....	202
N.2	The message.....	203
N.3	Generation of the SHR.....	203
N.4	Generation of the PHR.....	215
N.5	Generation of the PSDU	219
Annex O (informative)	Example of encoding a packet for MR-FSK PHY.....	229
O.1	Introduction.....	229
O.2	Example 1	230
O.2.1	Settings	230
O.2.2	Generation of the SHR.....	230
O.2.3	Generation of the PHR.....	230
O.2.4	Concatenating the SHR with the PHR and PSDU.....	230
O.3	Example 2	230
O.3.1	Settings	230
O.3.2	Generation of the SHR	231
O.3.3	Generation of the PHR	231

O.3.4	Bit sequence after data whitening of the PSDU and concatenation with PHR	231
O.3.5	Concatenating the SHR with the PHR and PSDU.....	231
O.4	Example 3	231
O.4.1	Settings	231
O.4.2	Generation of the SHR.....	232
O.4.3	Generation of the PHR.....	232
O.4.4	Concatenating the PHR, PSDU, tail bits, and pad bits	232
O.4.5	Encoding of the bit sequence	232
O.4.6	Interleaving of the bit sequence	232
O.4.7	Bit sequence after data whitening of the PSDU	233
O.4.8	Concatenating the SHR with the PHR and PSDU	233
O.5	Example 4	233
O.5.1	Generation of the SHR.....	233
O.5.2	Generation of the PHR.....	233
O.5.3	Concatenating the PHR, PSDU, tail bits, and pad bits	233
O.5.4	Encoding of the bit sequence	234
O.5.5	Interleaving of the bit sequence	234
O.5.6	Concatenating the SHR with the PHR and PSDU	234
O.6	Example 5	234
O.6.1	Generation of the SHR	234
O.6.2	Generation of the PHR	235
O.6.3	Generation of the PSDU	235
O.6.4	Concatenating the SHR with the PHR and PSDU	235
O.7	Example 6	235
O.7.1	Settings	235
O.7.2	Generation of the SHR.....	235
O.7.3	Generation of the PHR.....	235
O.7.4	Concatenating the PHR, PSDU, tail bits, and pad bits	236
O.7.5	Encoding of the bit sequence	236
O.7.6	Interleaving of the bit sequence	236
O.7.7	Bit sequence after data whitening of the PSDU	236
O.7.8	Concatenating the SHR with the PHR and PSDU	236

IEEE Standard for Local and metropolitan area networks—

Part 15.4: Low-Rate Wireless Personal Area Networks (LR-WPANs)

Amendment 3: Physical Layer (PHY) Specifications for Low- Data-Rate, Wireless, Smart Metering Utility Networks

IMPORTANT NOTICE: IEEE Standards documents are not intended to ensure safety, health, or environmental protection, or ensure against interference with or from other devices or networks. Implementers of IEEE Standards documents are responsible for determining and complying with all appropriate safety, security, environmental, health, and interference protection practices and all applicable laws and regulations.

This IEEE document is made available for use subject to important notices and legal disclaimers. These notices and disclaimers appear in all publications containing this document and may be found under the heading "Important Notice" or "Important Notices and Disclaimers Concerning IEEE Documents." They can also be obtained on request from IEEE or viewed at <http://standards.ieee.org/IPR/disclaimers.html>.

NOTE—The editing instructions contained in this amendment define how to merge the material contained therein into the existing base standard and its amendments to form the comprehensive standard.

The editing instructions are shown in ***bold italic***. Four editing instructions are used: change, delete, insert, and replace. ***Change*** is used to make corrections in existing text or tables. The editing instruction specifies the location of the change and describes what is being changed by using ~~striethrough~~ (to remove old material) and underscore (to add new material). ***Delete*** removes existing material. ***Insert*** adds new material without disturbing the existing material. Deletions and insertions may require renumbering. If so, renumbering instructions are given in the editing instruction. ***Replace*** is used to make changes in figures or equations by removing the existing figure or equation and replacing it with a new one. Editing instructions, change markings, and this NOTE will not be carried over into future editions because the changes will be incorporated into the base standard.¹

¹Notes in text, tables, and figures are given for information only and do not contain requirements needed to implement the standard.

2. Normative references

Insert the following new reference alphabetically into Clause 2:

ANSI X3.66-1979, Advanced Data Communication Control Procedures.²

²ANSI publications are available from the American National Standards Institute (<http://www.ansi.org>).

3. Definitions, acronyms, and abbreviations

3.1 Definitions

Insert the following definitions alphabetically into 3.1:

BT: shaping parameter for filtered FSK modulation, where B is the 3 dB bandwidth of the shaping filter, and T is the FSK symbol period.

common signaling mode (CSM): a common physical layer (PHY) mode used between smart metering utility network (SUN) devices implementing the multi-PHY management (MPM) scheme.

designated channel: a communication channel or conterminal aggregation of communication channels.

duty cycle: the ratio of the sum of the durations of all transmissions in a given period of continuous operation, to the duration of the given period of continuous operation.

multi-physical layer (PHY) layer management (MPM): A scheme that facilitates interoperability and negotiation among potential coordinators with different PHYs by permitting a potential coordinator to detect an operating network during its discovery phase using the common signaling mode (CSM) appropriate to the band being used.

physical layer (PHY) mode: a set of parameters that fully describe the characteristics of a transmitted signal, such that two devices implementing this set of parameters may successfully exchange packets.

smart metering utility network (SUN): a principally outdoor, low data rate wireless network that supports two-way communications among sensing, measurement, and control devices in the smart grid.

smart metering utility network (SUN) device: an entity containing an implementation of the medium access control (MAC) sublayer specified in this standard and the multi-rate and multi-regional frequency shift keying (MR-FSK) physical layer (PHY), and optionally the multi-rate and multi-regional orthogonal frequency division multiplexing (MR-OFDM) or the multi-rate and multi-regional offset quadrature phase-shift keying (MR-O-QPSK) PHY.

3.2 Acronyms and abbreviations

Insert the following acronyms alphabetically into 3.2:

BCH	Bose Chaudhuri Hocquenghem
BDE	bit differential encoding
CP	cyclic prefix
CSM	common signaling mode
DFT	discrete Fourier transform
EB	enhanced beacon
EBI	enhanced beacon interval
EBR	enhanced beacon request
FSK	frequency shift keying
HCS	header check sequence
IDFT	inverse discrete Fourier transform
IE	information element
ISR	interference-to-signal ratio

LTF	long training field
MCS	modulation and coding scheme
MDSSS	multiplexed direct sequence spread spectrum
MPM	multi-PHY layer management
MR-FSK	multi-rate and multi-regional frequency shift keying
MR-OFDM	multi-rate and multi-regional orthogonal frequency division multiplexing
MR-O-QPSK	multi-rate and multi-regional offset quadrature phase-shift keying
NBPAN	nonbeacon-enabled personal area network
NRNSC	nonrecursive and nonsystematic code
OTD	offset time duration
PAD	pad bits
PC	parity check
QAM	quadrature amplitude modulation
RSC	recursive and systematic code
SPC	single parity check
STF	short training field
SUN	smart metering utility network
TAIL	PPDU tail bit field
TPC	turbo product code

4. General description

Insert the following new subclause (4.1a) after 4.1:

4.1a Introduction to smart metering utility network (SUN)

SUNs enable multiple applications to operate over shared network resources, providing monitoring and control of a utility system. SUN devices are designed to operate in very large-scale, low-power wireless applications and often require using the maximum power available under applicable regulations, in order to provide long-range, point-to-point connections. Frequently, SUNs are required to cover geographically widespread areas containing a large number of outdoor devices. In these cases, SUN devices may employ mesh or peer-to-peer multihop techniques to communicate with an access point.

Three alternative PHYs are provided for SUN devices. The multi-rate and multi-regional frequency shift keying (MR-FSK) PHY provides good transmit power efficiency due to the constant envelope of the transmit signal. The multi-rate and multi-regional offset quadrature phase-shift keying (MR-O-QPSK) PHY shares the characteristics of the IEEE 802.15.4-2011 O-QPSK PHY, making multi-mode systems more cost effective and easier to design. The multi-rate and multi-regional orthogonal frequency division multiplexing (MR-OFDM) PHY provides higher data rates at higher spectral efficiency.

Insert the following two new subclauses (4.2a–4.2c) after 4.2:

4.2a MR-FSK Generic PHY mechanism

The MR-FSK Generic PHY mechanism provides a means to describe additional PHY modes in a standardized format. For SUN devices capable of supporting the MR-FSK Generic PHY mechanism, this enables:

- The flexibility to use a standard-defined mechanism to interface to previously deployed devices
- The flexibility to extend the existing IEEE Std 802.15.4, in order to take advantage of technology advances or to react to regulatory changes.

4.2b Mode switch mechanism

The mode switch mechanism enables a device using the MR-FSK PHY to change its symbol rate and/or modulation scheme on a packet-by-packet basis. This is done as a PHY layer operation, requiring minimal involvement from the MAC layer. A specific mode switch PPDU is used to inform the receiver of the mode switch and specifies the new PHY mode of the following PPDU.

Using the mode switch mechanism, the current PHY mode (i.e., symbol rate or modulation scheme) can be overridden for a single packet. For example, the mode switch mechanism can be invoked by a device that is configured to operate at the MR-FSK mode with a lower data rate (e.g., 50 kb/s) to enable higher data rate communications when needed. This might be used to facilitate a common communication PHY mode, while enabling higher data rate communications for those devices that are already established in the network. Also, this mechanism permits two devices using the FSK PHY to establish the communication in a different PHY mode.

To take advantage of this mechanism, the system implementer would typically configure devices with identical mode switch parameters. However, a source device wishing to use the mode switch mechanism would typically request SUN PHY capability information (including the mode switch parameter entries) from the destination device(s) to ensure that the mode switch mechanism, with the identical parameters, is supported by the destination device(s).

4.2c Multi-PHY management (MPM) of the SUN WPAN

Multiple, different SUN PHYs can operate in the same location and within the same frequency band. In order to mitigate interference, a multi-PHY management (MPM) scheme is specified for SUNs to facilitate inter-PHY coexistence. For this purpose, the MPM scheme facilitates interoperability and negotiation among potential coordinators with different PHYs by permitting a potential coordinator to detect an operating network during its discovery phase using the common signaling mode (CSM) appropriate to the band being used, as defined in Table 69a. The MPM procedure can be used in conjunction with the clear channel assessment (CCA) mechanism to provide coexistence.

5. MAC protocol

5.1 MAC functional description

Insert the following new paragraph before the last paragraph of 5.1:

For the MR-FSK PHY, the symbol duration used for MAC and PHY timing parameters, shown in Table 0, shall be the symbol duration of operating mode #1 specified in Table 134 and Table 135. For the MR-OFDM PHY, the symbol duration used for MAC timing parameters (*macLIFSPeriod* and *macSIFSPeriod*) shall be the symbol duration of MR-FSK operating mode #1 specified in Table 134 and Table 135, and the PHY symbol duration is defined in 18.2 and is to be used for *aTurnaroundTime*, *macAckWaitDuration*, and *aCCATime*. For the MR-O-QPSK PHY, the meaning of a symbol duration is described in 18.3.2.14.

Table 0—MR-FSK symbol duration used for MAC and PHY timing parameters

Frequency band (MHz)	MR-FSK symbol duration used for MAC and PHY timing parameters (μ s)
169.400–169.475 (Europe)	208+1/3
450–470 (US FCC Part 22/90)	104+1/6
470–510 (China)	20
779–787 (China)	20
863–870 (Europe)	20
896–901 (US FCC Part 90)	100
901–902 (US FCC Part 24)	100
902–928 (US ISM)	20
917–923.5 (Korea)	20
928–960 (US FCC Part 22/24/90/101)	100
920–928 (Japan)	20
950–958 (Japan)	20
1427–1518 (US FCC Part 90)/(Canada SRSP 301.4)	100
2400–2483.5 (Worldwide)	20

5.1.1 Channel access

Insert the following new subclause (5.1.1.2a) after 5.1.1.2:

5.1.1.2a Enhanced beacon (EB) timing for MPM procedure

In a beacon-enabled PAN, a SUN device operating as a coordinator transmits an enhanced beacon (EB) containing a Coexistence Specification information element (IE) at fixed intervals, in addition to the usual periodic beacons. Figure 9a shows the EB timing for beacon-enabled PANs.

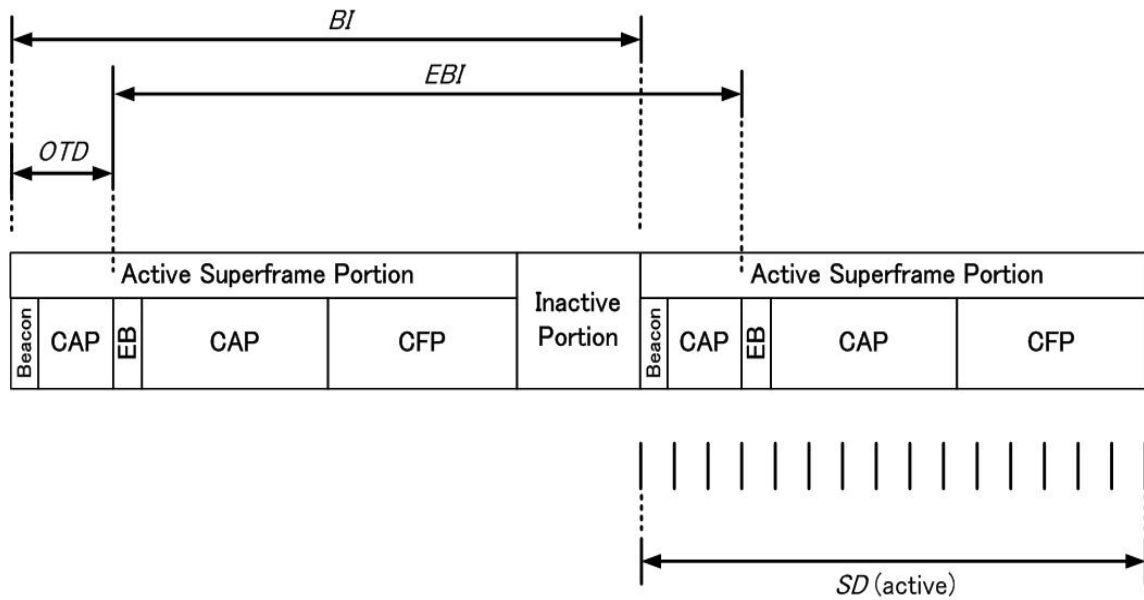

Figure 9a—Timing information for EB frames

The MAC PIB attribute *macEnhancedBeaconOrder* describes the interval at which the coordinator shall start transmissions of its EB frames. The values of *macEnhancedBeaconOrder* and the enhanced beacon interval (EBI) are related as follows:

$$EBI = aBaseSuperframeDuration \times 2^{macEnhancedBeaconOrder} \text{ symbols}$$

The value of *macEnhancedBeaconOrder* should not be larger than the value of *macBeaconOrder*.

The time offset between the start of the periodic beacon transmission and the start of the following EB transmission is described by the MAC PIB attribute *macOffsetTimeSlot*. The values of *macOffsetTimeSlot* and offset time duration (OTD) are related as follows:

$$OTD = aBaseSlotDuration \times macOffsetTimeSlot \text{ symbols}$$

In a nonbeacon-enabled PAN (NBPAN), the time offset between the starts of two EB frames is described by the NBPAN order, *macNBPANEnhancedBeaconOrder*. The resolution of time shall be *aBaseSlotDuration*. The values of *macNBPANEnhancedBeaconOrder* and the NBPAN EBI (EBI_{NBPAN}) are related as follows:

$$EBI_{NBPAN} = aBaseSlotDuration \times macNBPANEnhancedBeaconOrder \text{ symbols}$$

5.1.2 Starting and maintaining PANs

5.1.2.3 Starting and realigning a PAN

5.1.2.3.1 Starting a PAN

Change the first paragraph of 5.1.2.3.1 as indicated:

A PAN should be started by an FFD only after having first performed a MAC sublayer reset, by issuing the MLME-RESET.request primitive, as described in 6.2.8.1, with the SetDefaultPIB parameter set to TRUE, an active channel scan, and a suitable PAN identifier selection. If the device is a SUN device operating as a coordinator, a passive scan for an EB Coexistence Specification IE, as described in 5.1.13, should take place prior to the active channel scan. The algorithm for selecting a suitable PAN identifier from the list of PAN descriptors returned from the active channel scan procedure is out of the scope of this standard. In addition, an FFD should set *macShortAddress* to a value less than 0xffff.

5.1.6 Transmission, reception, and acknowledgment

5.1.6.4 Use of acknowledgments and retransmissions

5.1.6.4.2 Acknowledgment

Insert the following new paragraph after the first paragraph of 5.1.6.4.2:

A SUN device may set the Enhanced Acknowledgment bit in the SUN PHY Capabilities IE, as described in 5.2.4.20b, to indicate that it supports enhanced acknowledgment frames.

Insert the following new subclause (5.1.13) after 5.1.12.5:

5.1.13 MPM procedure for inter-PHY coexistence

To facilitate interference avoidance among multiple SUNs utilizing different PHYs in the same location, all SUN coordinators operating at a duty cycle of more than 1% shall support the MPM procedures. In the MPM scheme, EBs are sent using the CSM, as defined in Table 69a. EBs used in the MPM procedures described here are EBs containing a Coexistence Specification IE.

The transmission of EBs should take place in all the channels defined for CSM, as described in Table 69a, that overlap with the channel(s) in operation. The scanning for EBs and the transmission of enhanced beacon requests (EBRs) should take place in all the channels defined for CSM that overlap with the channel of interest or at least two channels for PHY modes where the CSM requires frequency hopping.

In a beacon-enabled PAN, an existing coordinator³ shall transmit an EB at a fixed interval by using CSM. Any intending coordinator⁴ shall first scan for an EB until the expiration of the EBI or until an EB is detected, whichever occurs first. If an intending coordinator detects an EB, it shall either occupy another channel, achieve synchronization with the existing PAN, or stop communication. While specific mechanisms to achieve synchronization between two PANs utilizing different PHY modes are implementation-dependent, the timing information applicable for synchronization purposes is specified in the EB. Figure 34u illustrates the MPM procedure.

³An existing coordinator is a coordinator currently operating a network.

⁴An intending coordinator is a coordinator intending to start a separate network.

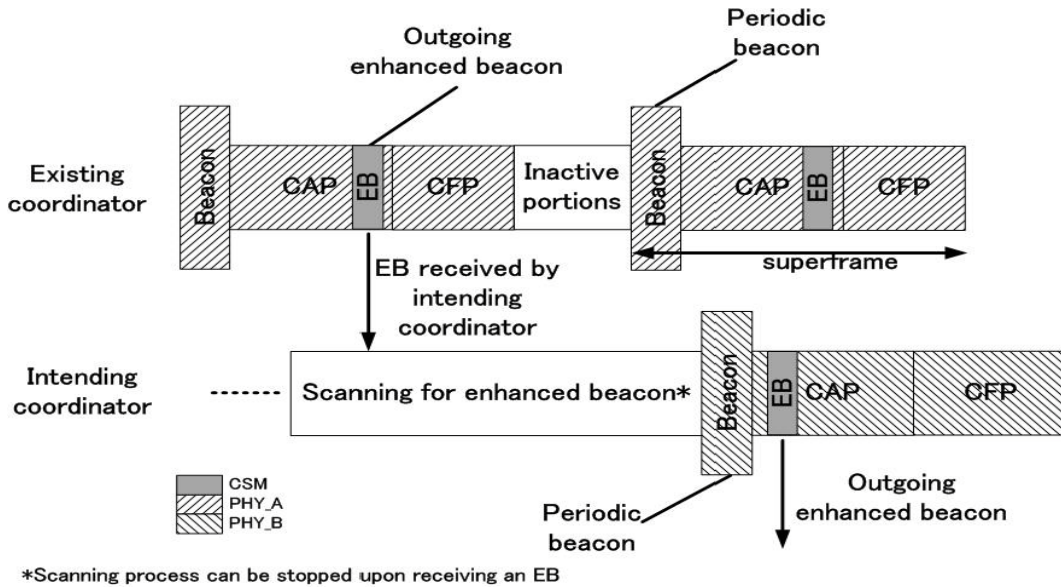

Figure 34u—Inter-PHY mode coexistence in a beacon-enabled PAN

The EB shall only be sent in the CAP.

In a nonbeacon-enabled PAN, an existing coordinator should transmit an EB periodically using the CSM. Any intending coordinator shall first scan for an EB until the expiration of $EBI_{NB PAN}$ or until an EB is detected, whichever occurs first. The illustration of the procedure is given in Figure 34v.

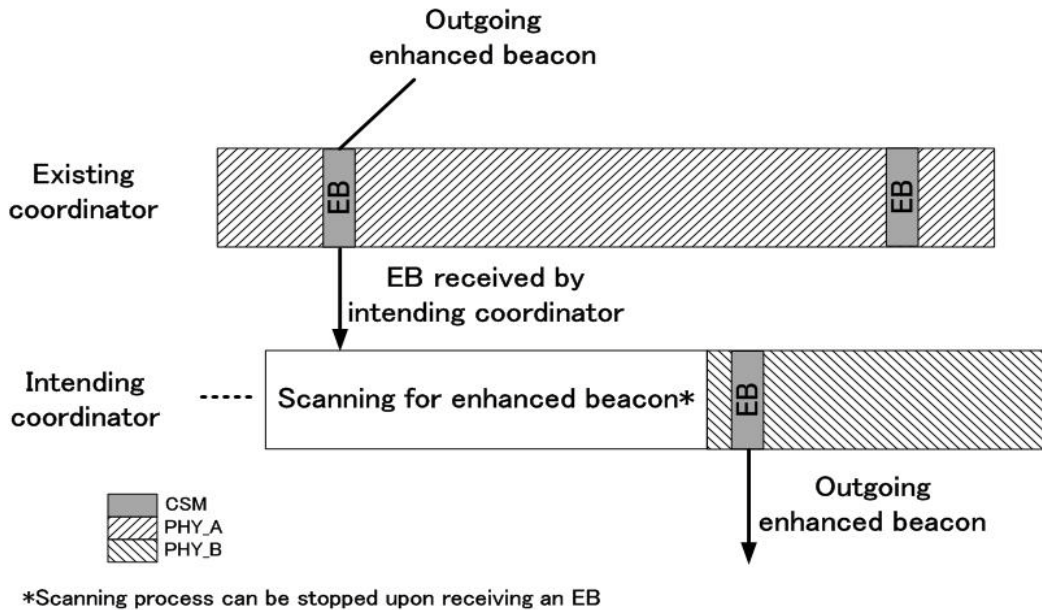

Figure 34v—Inter-PHY mode coexistence in a nonbeacon-enabled PAN

Alternatively, an EB may be obtained in an on-demand manner. In this case, an EBR containing the ID of the Coexistence Specification IE in the list of IE IDs is sent by the intending coordinator requesting an EB from the existing coordinator. Upon receiving an enhanced beacon request (EBR), the existing coordinator (or any other device within the same area that is capable of receiving and transmitting an EBR/EB using the CSM) may respond by sending an EB to the intending coordinator. The intending coordinator should transmit an EBR at least once every $EBI_{NB PAN}$. To increase the probability of receiving an EBR, the existing coordinator may periodically allocate a fraction of the CAP time to scan for the EBR in CSM. The illustration of the procedure is given in Figure 34w.

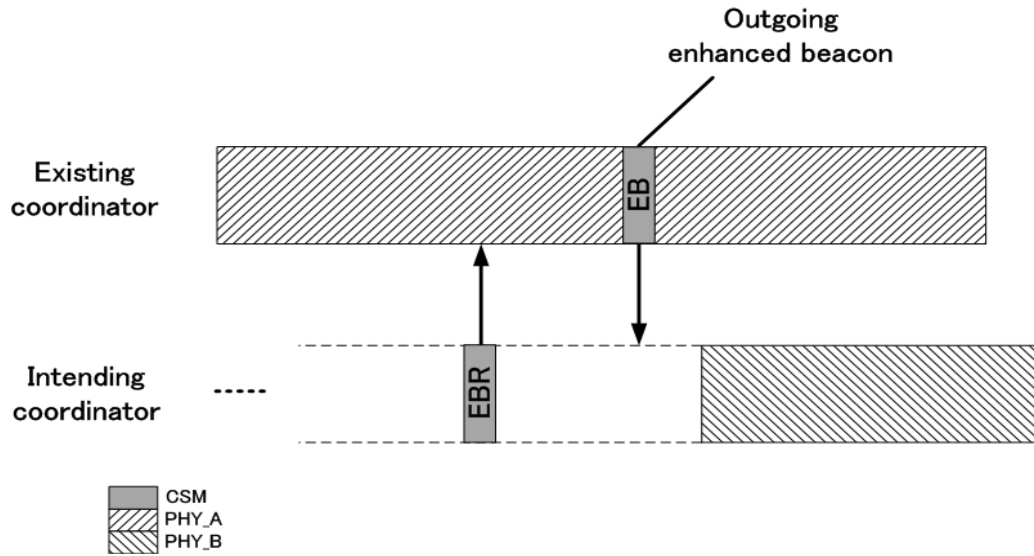

Figure 34w—Alternative method for inter-PHY mode coexistence in a nonbeacon-enabled PAN

5.2 MAC frame formats

5.2.1 General MAC frame format

Replace *Figure 35* with the following figure:

Octets: 1/2	0/1	0/2	0/1/2/8	0/2	0/1/2/8	0/1/5/6/ 10/14	variable	variable	2/4	
Frame Control	Sequence Number	Destination PAN Identifier	Destination Address	Source PAN Identifier	Source Address	Auxiliary Security Header	Information Elements		Frame Payload	FCS
							Header IEs	Payload IEs		
MHR							MAC Payload		MFR	

Figure 35—General MAC frame format

5.2.1.9 FCS field

Change the first paragraph of 5.2.1.9 as indicated:

The FCS field contains a 16-bit ITU-T CRC or a 32-bit CRC equivalent to ANSI X3.66-1979. The FCS is calculated over the MHR and MAC payload parts of the frame; these parts together are referred to as the calculation field. Only devices compliant with one or more of the SUN PHYs shall implement the 4-octet FCS. For these devices, the default FCS length shall be 4 octets.

Change the second paragraph of 5.2.1.9 as indicated:

The 2-octet FCS shall be calculated using the following standard generator polynomial of degree 16:

Change the third paragraph of 5.2.1.9 as indicated:

The 2-octet FCS shall be calculated for transmission using the following algorithm:

Change the sixth paragraph of 5.2.1.9 as indicated:

The 2-octet FCS for this case would be the following:

Change the caption of Figure 37 as indicated:

Figure 37—Typical 2-octet FCS implementation

Insert the following paragraphs at the end of 5.2.1.9:

The 4-octet FCS is calculated using the following standard generator polynomial of degree 32:

$$G_{32}(x) = x^{32} + x^{26} + x^{23} + x^{22} + x^{16} + x^{12} + x^{11} + x^{10} + x^8 + x^7 + x^5 + x^4 + x^2 + x + 1$$

The 4-octet FCS is the one's complement of the (modulo 2) sum of the two remainders in a) and b):

- a) The remainder resulting from $[(x^k \times (x^{31} + x^{30} + \dots)]$ divided (modulo 2) by $G_{32}(x)$, where the value k is the number of bits in the calculation field.
- b) The remainder resulting from the calculation field contents, treated as a polynomial, is multiplied by x^{32} and then divided by $G_{32}(x)$.

At the transmitter, the initial remainder of the division shall be preset to all ones and then modified via division of the calculation field by the generator polynomial $G_{32}(x)$. The one's complement of this remainder is the 4-octet FCS field. The FCS field is transmitted commencing with the coefficient of the highest order term.

At the receiver, the initial remainder shall be preset to all ones. The serial incoming bits of the calculation field and FCS, when divided by $G_{32}(x)$ in the absence of transmission errors, result in a unique nonzero remainder value. The unique remainder value is the polynomial shown:

$$x^{31} + x^{30} + x^{26} + x^{25} + x^{24} + x^{18} + x^{15} + x^{14} + x^{12} + x^{11} + x^{10} + x^8 + x^6 + x^5 + x^4 + x^3 + x + 1$$

Upon transmission, if the length of the calculation field is less than 4 octets, the FCS computation shall assume padding the calculation field by appending zero value octets to the most significant bits to make the

calculation field length exactly 4 octets; however, these pad bits shall not be transmitted. Upon reception, if the length of the calculation field is less than 4 octets, the received calculation field shall be appended with zero value octets to the most significant bits to make the calculation field length exactly 4 octets prior to computing the FCS for validation.

As an example, consider an acknowledgment frame with no payload and the following 3-byte MHR:

0100 0000 0000 0000 0101 0110 [leftmost bit (b_0) transmitted first in time]
 b_0 b_{23}

Prior to FCS computation, the zero padded calculation field is given as follows:

0100 0000 0000 0000 0101 0110 0000 0000
 b_0 b_{31}

The 4-octet FCS for this case would be the following:

0101 1101 0010 1001 1111 1010 0010 1000 [leftmost bit (r_0) transmitted first in time]
 r_0 r_{31}

5.2.2 Format of individual frame types

5.2.2.1 Beacon frame format

Replace Figure 38 and Figure 40a with the following figures:

Octets: 2	1	4/10	0/5/6/ 10/14	2	variable	variable	variable	2/4
Frame Control	Sequence Number	Addressing fields	Auxiliary Security Header	Superframe Specification	GTS fields	Pending address fields	Beacon Payload	FCS
MHR				MAC Payload				MFR

Figure 38—Beacon frame format

Octets: 1/2	0/1	variable	0/1/5/6/10/14	variable		variable	2/4
Frame Control	Sequence Number	Addressing fields	Auxiliary Security Header	Information Elements		Beacon Payload	FCS
				Header IEs	Payload IEs		
MHR				MAC Payload		MFR	

Figure 40a—Enhanced beacon frame format

5.2.2.2 Data frame format

Replace Figure 46 with the following figure:

Octets: 2	0/1	variable	0/1/5/6/10/14	variable		variable	2/4
Frame Control	Sequence Number	Addressing fields	Auxiliary Security Header	Information Elements		Data Payload	FCS
				Header IEs	Payload IEs		
MHR				MAC Payload		MFR	

Figure 46—Data frame format

5.2.2.3 Acknowledgment frame format

Replace Figure 47 and Figure 47a with the following figures:

Octets: 2	1	2/4
Frame Control	Sequence Number	FCS
MHR		MFR

Figure 47—Acknowledgment frame format

Octets: 1/2	0/1	0/2	0/1/2/8	0/2	0/1/2/8	0/1/5/6/10/14	variable		variable	2/4
Frame Control	Sequence Number	Destination PAN Identifier	Destination Address	Source PAN Identifier	Source Address	Auxiliary Security Header	Information Elements		Payload	FCS
							Header IEs	Payload IEs		
MHR							MAC Payload		MFR	

Figure 47a—Enhanced Acknowledgment frame format

5.2.2.4 MAC command frame format

Replace Figure 48 with the following figure:

Octets: 2	0/1	variable	0/1/5/6/10/14	variable		1	variable	2/4
Frame Control	Sequence Number	Addressing fields	Auxiliary Security Header	Information Elements		Command Frame Identifier	Command Payload	FCS
				Header IEs	Payload IEs			
MHR					MAC Payload			MFR

Figure 48—MAC command frame format

5.2.4 Information element

5.2.4.5 MLME Information Elements

Insert the following new entries into Table 4d:

Table 4d—Sub-ID allocation for short form

Sub-ID value	Content length	Name	Description
0x21	9	Coexistence Specification	Conveys the parameters that define the EB
0x22	Variable	SUN PHY Capabilities	Declares the PHY Capabilities of the device
0x23	16	MR-FSK Generic PHY Descriptor	Declares one MR-FSK Generic PHY Descriptor
0x24	3	Mode Switch Parameter Entry	Declares one Mode Switch Parameter Entry
0x25–0x3f	—	Reserved	—

Insert the following new subclauses (5.2.4.20a–5.2.4.20d) after 5.2.4.20:

5.2.4.20a Coexistence Specification IE

The Coexistence Specification IE shall be formatted as illustrated in Figure 48oo. The leftmost seven octets are information for a beacon-enabled network, and the rightmost six octets are information for a nonbeacon-enabled network.

The Beacon Order field, Superframe Order field, and Final CAP Slot field are as specified in 5.2.2.1.2.

The Enhanced Beacon Order field specifies the transmission interval of the EB frames. See 5.1.1.2a for an explanation of the relationship between EB order and EBI.

The Offset Time Slot field specifies the time offset between the periodic beacon and the following EB, as described in 5.1.1.2a.

The CAP Backoff Offset field specifies the actual slot position in which the EB is transmitted due to the backoff procedure in the CAP.

Bit #: 0–3	4–7	8–11	12–15	16–19	20–23	24–55	56–71
Beacon Order	Superframe Order	Final CAP Slot	Enhanced Beacon Order	Offset Time Slot	CAP Backoff Offset	Channel Page	NBPAN Enhanced Beacon Order

Figure 48oo—Format of the Coexistence Specification IE

The NBPAN Enhanced Beacon Order field specifies the transmission interval between consecutive EBs in the nonbeacon-enabled mode. The valid range for this field shall be 0–16383.

The Channel Page field shall contain a valid channel page value as defined in 8.1.2.10.

If the Beacon Order field is set to 15, the Superframe Order, Final CAP Slot, and Offset Time Slot fields shall be set to zero upon transmission and ignored upon reception. When generated in response to an EBR that contained a list of requested IEs, the content of the EB shall include the IEs corresponding to the requested IE IDs, as shown in Table 4j.

Table 4j— EBR IE per enabled attribute

PIB attribute	IE type	IEs to include
<i>macMPMIE</i>	MLME payload	Coexistence Specification IE (as defined in 5.2.4.20a)

5.2.4.20b SUN device capabilities IE

The SUN device capabilities IE, shown in Figure 48pp, declares which SUN features a device supports.

Octets: 1	2	Variable
SUN Features	Frequency Bands Supported	PHY Type Descriptor(s)

Figure 48pp—SUN device capabilities IE format

The SUN Features field is encoded as a bitmap in the first octet of the IE Content field, as illustrated in Figure 48pp with a detailed description in Figure 48qq. A bit set to one indicates the feature is supported. Otherwise, the feature is not supported.

The bits of the SUN Features field are defined as follows:

- Bit 0 indicates support for enhanced acknowledgment frames, as described in 5.1.6.4.2.
- Bit 1 indicates support for data whitening, as described in 18.1.3.
- Bit 2 indicates support for interleaving, as described in 18.1.2.5.

Octets: 1							
Bit #: 0	1	2	3	4	5	6	7
Enhanced ACK	Data Whitening	Interleaving	SFD G1	NRNSC FEC	RSCFEC	Mode Switch	Reserved

Figure 48qq—SUN Features field format

- Bit 3 indicates support for start-of-frame delimiter (SFD) Group 1, as described in 18.1.1.2.
- Bit 4 indicates support for nonrecursive and nonsystematic code (NRNSC) forward error correction (FEC), as described in 18.1.2.4.
- Bit 5 indicates support for recursive and systematic code (RSC) forward error correction (FEC), as described in 18.1.2.4.
- Bit 6 indicates support for the mode switch mechanism, as described in 18.1.4.

The Frequency Bands Supported field is a bitmap indexed by the frequency band identifier values given in Table 68f. The least significant bit of the bitmap corresponds to frequency band identifier zero. A bit set to one indicates that the device supports operation in that frequency band; otherwise, it does not.

The PHY Type Descriptor field is shown in Figure 48rr.

Octets: 2			2
Bit #: 0–3	4	5–15	0–15
PHY Type	All Frequency Bands	PHY Modes Supported (PHY Mode ID bitmap: $b_0 \dots b_{10}$)	Specific Frequency Bands (only present if All Frequency Bands = 0)

Figure 48rr—PHY Type Descriptor field format

The PHY Type field contains an unsigned integer whose value identifies a PHY Type defined in Table 4k.

The All Frequency Bands field indicates whether the optional Specific Frequency Bands field is present. If the All Frequency Bands field is set to one, the optional Specific Frequency Bands field is absent and the PHY Type is supported in all frequency bands declared in the Frequency Bands Supported field of the SUN device capabilities IE. If the All Frequency Bands field is set to zero, the optional Specific Frequency Bands field is present and the PHY Type is only supported in the frequency bands declared in the Specific Frequency Bands field of this PHY Type Descriptor.

The PHY Modes Supported field is a bitmap indicating which PHY modes are supported for the PHY Type. The PHY modes for each possible PHY Type are defined in Table 4l, Table 4m, Table 4n, Table 4o, Table 4p, and Table 4q. A bit set to one in bit b_n of the PHY Mode ID bitmap indicates that the PHY Mode with ID n in the table of PHY Modes corresponding to the PHY Type is supported; otherwise, it is not supported.

The optional Specific Frequency Bands field is encoded in the same manner as the Frequency Bands Supported field of the SUN device capabilities IE.

Table 4k—Modulation scheme encoding

PHY type	Modulation scheme
0	Filtered FSK-A
1	Filtered FSK-B
2	O-QPSK-A
3	O-QPSK-B
4	O-QPSK-C
5	OFDM Option 1
6	OFDM Option 2
7	OFDM Option 3
8	OFDM Option 4
9–15	Reserved

Filtered FSK PHY modes are defined in Table 4l and Table 4m. For additional information on Filtered FSK,

Table 4l—Filtered FSK-A PHY mode encoding

PHY Mode ID	Narrowband FSK PHY mode
0	4.8 kb/s; Filtered 2FSK; mod index = 1.0; channel spacing = 12.5 kHz
1	9.6 kb/s; Filtered 4FSK; mod index = 0.33; channel spacing = 12.5 kHz
2	10 kb/s; Filtered 2FSK; mod index = 0.5; channel spacing = 12.5 kHz
3	20 kb/s; Filtered 2FSK; mod index = 0.5; channel spacing = 12.5 kHz
4	40 kb/s; Filtered 2FSK; mod index = 0.5; channel spacing = 12.5 kHz
5	4.8 kb/s; Filtered 2FSK; mod index = 0.5; channel spacing = 12.5 kHz
6	2.4 kb/s; Filtered 2FSK; mod index = 2.0; channel spacing = 12.5 kHz
7	9.6 kb/s; Filtered 4FSK; mod index = 0.33; channel spacing = 12.5 kHz
8–10	Reserved

see 18.1.2.

O-QPSK PHY modes are defined in Table 4n, Table 4o, and Table 4p.

For each OFDM option, the supported MCSs are defined in Table 4q.

In each encoding of PHY modes in the PHY Type Descriptor field, a bit set to one in a bit position corresponding to a given modulation scheme in Table 4l, Table 4m, Table 4n, Table 4o, Table 4p, and Table 4q indicates the PHY mode for that modulation scheme is supported. A value of zero similarly indicates that the PHY mode is not supported.

Table 4m—Filtered FSK-B PHY mode encoding

PHY Mode ID	FSK PHY mode
0	50 kb/s; Filtered 2FSK; mod index = 1.0; channel spacing = 200 kHz
1	100 kb/s; Filtered 2FSK; mod index = 1.0; channel spacing = 400 kHz
2	150 kb/s; Filtered 2FSK; mod index = 0.5; channel spacing = 400 kHz
3	200 kb/s; Filtered 2FSK; mod index = 0.5; channel spacing = 400 kHz
4	200 kb/s; Filtered 4FSK; mod index = 0.33; channel spacing = 400 kHz
5	200 kb/s; Filtered 2FSK; mod index = 1.0; channel spacing = 600 kHz
6	400 kb/s; Filtered 4FSK; mod index = 0.33; channel spacing = 600 kHz
7–10	Reserved

Table 4n—O-QPSK-A PHY mode encoding

PHY Mode ID	Narrowband O-QPSK PHY mode
0	chip rate = 100 kchip/s; SpreadingMode = DSSS; RateMode = 0; data rate = 6.25 kb/s
1	chip rate = 100 kchip/s; SpreadingMode = DSSS; RateMode = 1; data rate = 12.5 kb/s
2	chip rate = 100 kchip/s; SpreadingMode = DSSS; RateMode = 2; data rate = 25 kb/s
3	chip rate = 100 kchip/s; SpreadingMode = DSSS; RateMode = 3; data rate = 50 kb/s
4–10	Reserved

Table 4o—O-QPSK-B PHY mode encoding

PHY Mode ID	O-QPSK PHY mode
0	chip rate = 1000 kchip/s; SpreadingMode = DSSS; RateMode = 0; data rate = 31.25 kb/s
1	chip rate = 1000 kchip/s; SpreadingMode = DSSS; RateMode = 1; data rate = 125 kb/s
2	chip rate = 1000 kchip/s; SpreadingMode = DSSS; RateMode = 2; data rate = 250 kb/s
3	chip rate = 1000 kchip/s; SpreadingMode = DSSS; RateMode = 3; data rate = 500 kb/s
4	chip rate = 1000 kchip/s; SpreadingMode = MDSSS; RateMode = 0; data rate = 62.5 kb/s
5	chip rate = 1000 kchip/s; SpreadingMode = MDSSS; RateMode = 1; data rate = 125 kb/s
6	chip rate = 1000 kchip/s; SpreadingMode = MDSSS; RateMode = 2; data rate = 250 kb/s
7	chip rate = 1000 kchip/s; SpreadingMode = MDSSS; RateMode = 3; data rate = 500 kb/s
8–10	Reserved

The value of the SUN PHY Capabilities IE length field is computed as follows:

$$Length = 1 + 2 + 2 \times NumPHYTypeAllFreq1 + 4 \times NumPHYTypeAllFreq0$$

Table 4p—O-QPSK-C PHY mode encoding

PHY Mode ID	O-QPSK PHY mode
0	chip rate = 2000 kchip/s; SpreadingMode = DSSS; RateMode = 0; data rate = 31.25 kb/s
1	chip rate = 2000 kchip/s; SpreadingMode = DSSS; RateMode = 1; data rate = 125 kb/s
2	chip rate = 2000 kchip/s; SpreadingMode = DSSS; RateMode = 2; data rate = 250 kb/s
3	chip rate = 2000 kchip/s; SpreadingMode = DSSS; RateMode = 3; data rate = 500 kb/s
4	chip rate = 2000 kchip/s; SpreadingMode = MDSSS; RateMode = 0; data rate = 62.5 kb/s
5	chip rate = 2000 kchip/s; SpreadingMode = MDSSS; RateMode = 1; data rate = 125 kb/s
6	chip rate = 2000 kchip/s; SpreadingMode = MDSSS; RateMode = 2; data rate = 250 kb/s
7	chip rate = 2000 kchip/s; SpreadingMode = MDSSS; RateMode = 3; data rate = 500 kb/s
8–10	Reserved

Table 4q—OFDM PHY mode encoding

PHY Mode ID	OFDM PHY modes (Option 1,2,3,4)
0	MCS0 supported
1	MCS1 supported
2	MCS2 supported
3	MCS3 supported
4	MCS4 supported
5	MCS5 supported
6	MCS6 supported
7–10	Reserved

where

$NumPHYTypeAllFreq1$ is the number of PHY Type Descriptor fields that have the All Frequency Bands field set to one

$NumPHYTypeAllFreq0$ is the number of PHY Type Descriptor fields that have the All Frequency Bands field set to zero

5.2.4.20c MR-FSK Generic PHY Descriptor IE

The Generic PHY Descriptor IE is encoded as shown in Figure 48ss.

The Modulation Order, Modulation Scheme, and MR-FSK Generic PHY Descriptor ID fields all contain unsigned integers, as defined in Table 71a.

The Modulation Index field is encoded as an unsigned integer with permissible values in the range 0–45. Values in the range 46–63 are undefined. The value of the modulation index (MI) for filtered 2FSK is computed using the value of the Modulation Index field in the following way:

Octets: 1			1		4	2	4	4
Bit #: 0–1	2–3	4–7	Bit #: 0–5	6–7	1 st Channel Center Frequency	Number of Channels	Channel Spacing	Symbol Rate
Modulation Order	Modulation Scheme	MR-FSK Generic PHY Descriptor ID	Modulation Index	BT				

Figure 48ss—MR-FSK Generic PHY Descriptor IE format

$$MI = 0.25 + \text{Modulation Index} \times 0.05$$

The *MI* for filtered 4FSK shall be one third of the value computed for filtered 2FSK.

The BT field is encoded as an unsigned integer, as defined in Table 4r.

Table 4r—BT Encoding

BT field	BT
0	0.5
1	1.0
2–3	Reserved

The 1st Channel Center Frequency field contains an unsigned integer whose value is the center frequency of the first channel in hertz.

The Number of Channels field contains an unsigned integer whose value is the number of channels for the Generic PHY.

The Channel Spacing field contains an unsigned integer whose value is the difference between adjacent channel center frequencies in hertz.

The Symbol Rate field contains an unsigned integer whose value is the number of symbols transmitted per second.

5.2.4.20d Mode Switch Parameter Entry IE

The Mode Switch Parameter Entry IE is encoded as shown in Table 48tt.

The Secondary FSK SFD field value is set to one if a secondary SFD is present; otherwise, it is set to zero, as described in Table 71b.

The Target Mode field contains an unsigned integer indicating the PHY Mode of the new mode PPDU. The values are as defined in Table 4k.

The Source Mode field contains the mode that is used to transmit the mode switch PPDU. It is set to zero for 2FSK or to one for 4FSK.

Octets: 1				1	1
Bit #: 0	1–4	5	6–7	Settling Delay	Secondary FSK Preamble Length
Secondary FSK SFD	Target Mode	Source Mode	Mode Switch Parameter Entry Index		

Figure 48tt—Mode Switch Parameter Entry IE format

The Mode Switch Parameter Entry Index field contains an unsigned integer whose value is the index into the *phyModeSwitchParameterEntries* PIB attribute array containing the Mode Switch Parameter Entry.

The Settling Delay field contains an unsigned integer whose value times two is the settling delay in microseconds (0–510 μ sec), as described in Table 71b.

The Secondary FSK Preamble Length field contains an unsigned integer whose value is the number of preamble repetitions for the secondary preamble when the new mode is MR-FSK, as described in Table 71b.

6. MAC services

6.2 MAC management service

6.2.4 Communications notification primitives

6.2.4.1 MLME-BEACON-NOTIFY.indication

Insert the following new parameter at the end of the list in 6.2.4.1 (before the closing parenthesis):

CoexSpecification

Insert the following new row at the end of Table 16:

Table 16—MLME-BEACON-NOTIFY.indication parameters

Name	Type	Valid Range	Description
CoexSpecification	Set of octets	As defined in 5.2.4.20a	The information on the multi-PHY management (MPM)

6.2.10 Primitives for channel scanning

6.2.10.1 MLME-SCAN.request

Insert the following new parameters at the end of the list in 6.2.10.1 (before the closing parenthesis):

MPMScanDurationBPAN,
MPMScanDurationNBPAN,
MPMScan,
MPMScanType

Insert the following new rows at the end of Table 30:

6.2.12 Primitives for updating the superframe configuration

6.2.12.1 MLME-START.request

Insert the following new parameters at the end of the list in 6.2.12.1 (before the closing parenthesis)

IEID,
EnhancedBeaconOrder,
OffsetTimeSlot,
NBPANEnhancedBeaconOrder

Change Table 34 (the entire table is not shown) as indicated. The description of the parameter BeaconOrder is reproduced here to assist the reader. No changes are made to this description.

Table 30—MLME-SCAN.request parameters

Name	Type	Valid range	Description
MPMScanDurationBPAN	Integer	0–14	The maximum time spent scanning for an EB in a beacon-enabled PAN on the channel is $[aBaseSuperframeDuration * 2^n]$ symbols, where symbol refers to the symbol time in the current PHY, and n is equal to MPMScanDurationBPAN. See 5.1.1.2a.
MPMScanDurationNBPAN	Integer	1–16383	The maximum time spent scanning for an EB in a nonbeacon-enabled PAN on the channel is $[aBaseSlotDuration * n]$ symbols, where symbol refers to the symbol time in the current PHY, and n is equal to MPMScanDurationNBPAN. See 5.1.1.2a.
MPMScan	Boolean	TRUE or FALSE	This parameter is only valid for SUN devices. When set to TRUE, an MPM scan is invoked and the ScanDuration parameter shall be ignored. When set to FALSE, the scan duration shall be set according to the ScanDuration parameter; the MPMScanType, MPMScanDurationBPAN, and MPMScanDurationNBPAN parameters shall be ignored.
MPMScanType	Enumeration	BPAN or NBPAN	This parameter is only valid for SUN devices. When the MPMScan parameter is set to TRUE and the MPMScanType parameter is set to BPAN, the scan duration shall be set according to the MPMScanDurationBPAN parameter. When the MPMScan parameter is set to TRUE and the MPMScanType parameter is set to NBPAN, the scan duration shall be set according to the MPMScanDurationNBPAN parameter.

Insert the following new paragraphs before the last paragraph of 6.2.12.1:

In a beacon-enabled PAN (BeaconOrder < 15), the MLME examines the OffsetTimeOrder parameter to determine the time to begin transmitting the EB following the periodic beacon. EB intervals are determined by the value of the EnhancedBeaconOrder parameter.

In a nonbeacon-enabled PAN (BeaconOrder = 15), the MLME examines the NBPANEnhancedBeaconOrder parameter to determine the interval between the start of two EBs.

See 5.1.1.2a for the description of EB timing.

Table 34—MLME-START.request primitives

Name	Type	Valid range	Description
BeaconOrder	Integer	0–15	Indicates the frequency with which the beacon is transmitted, as defined in 5.1.1.1.
<u>IEID</u>	<u>List of IEs</u>	<u>See Table 4d</u>	<u>Determines which IEs are sent in the EB.</u>
<u>EnhancedBeaconOrder</u>	<u>Integer</u>	<u>0–15</u>	<u>Indicates how often the EB is to be transmitted in a beacon-enabled PAN. A value of 15 indicates that no EB will be transmitted. See 5.1.1.2a.</u>
<u>OffsetTimeSlot</u>	<u>Integer</u>	<u>1–15</u>	<u>Indicates the time difference between the EB and the preceding periodic beacon. See 5.1.1.2a.</u>
<u>NBPANEnhancedBeaconOrder</u>	<u>Integer</u>	<u>0–16383</u>	<u>Indicates how often the EB is to be transmitted in a nonbeacon-enabled PAN (i.e., <i>macBeaconOrder</i> = 15). A value of 16383 indicates that no EB will be transmitted. See 5.1.1.2a.</u>

6.3 MAC data service

6.3.1 MCPS-DATA.request

Insert the following new parameters at the end of the list in 6.3.1 (before the closing parenthesis):

ModeSwitch,
NewModeSUNPage,
ModeSwitchParameterEntry

Change Table 46 (the entire table is not shown) as indicated:

Table 46—MCPS-DATA.request parameters

Name	Type	Valid range	Description
DataRate	Integer	0–48	Indicates the data rate. For CSS PHYs, a value of one indicates 250 kb/s, while a value of two indicates 1 Mb/s. For UWB PHYs, values 1-4 are valid and are defined in 14.2.6.1. For the MR-OFDM PHY, values 1–7 are valid; <u>each data rate value corresponds to the variable MCS{(data rate value)–1}, as described in Table 148. For the MR-O-QPSK PHY with SpreadingMode set to DSSS, values 1–4 are valid; each data rate value corresponds to the RateMode parameter plus one, as described in Table 166. For the MR-O-QPSK PHY with SpreadingMode set to MDSSS, values 5–8 are valid; each data rate value corresponds to the RateMode parameter plus five, as described in Table 167. For all other PHYs, the parameter is set to zero.</u>
<u>ModeSwitch</u>	Boolean	TRUE or FALSE	<p>A value of TRUE instructs the PHY entity to <u>send a mode switch PDU first and then a following PDU that contains the PSDU using the associated mode switch parameters. The mode switch PDU is transmitted using the PHY mode specified by phyCurrentSUNPageEntry. The PDU containing the PSDU is transmitted using the PHY mode specified by NewModeSUNPageEntry.</u></p> <p>A value of FALSE instructs the PHY to <u>send the PSDU in a single PDU using the PHY mode specified by phyCurrentSUNPageEntry on phyCurrentChannel.</u></p> <p><u>This parameter is only valid for MR-FSK PHY, as described in 18.1.1.4 and 18.1.4.</u></p>
<u>NewModeSUNPageEntry</u>	Bitmap	0x00000000–0xffffffff	The modulation scheme and particular PHY mode for the new mode as defined by the <u>channel page structure. The type and valid range are the same as defined for phyCurrentSUNPageEntry. This parameter is only valid if ModeSwitch = TRUE.</u>
<u>ModeSwitchParameterEntry</u>	Integer	0x00–0x03	The mode switch parameter entry specifies the <u>index in the phyModeSwitchParameterEntries array for the ModeSwitchDescriptor to be used for this PHY mode switch. This parameter is only valid if ModeSwitch = TRUE.</u>

6.3.3 MCPS-DATA.indication

Insert the following new parameter at the end of the list in 6.3.3 (before the closing parenthesis):

ModeSwitchPacketReceived

Insert the following new row at the end of Table 48:

Table 48—MCPS-DATA.indication parameters

Name	Type	Valid range	Description
ModeSwitchPacketReceived	Boolean	TRUE or FALSE	TRUE if a PHY mode switch packet is received.

6.4 MAC constants and PIB attributes

6.4.1 MAC constants

Change Table 51 (the entire table is not shown) as indicated. The descriptions of the constants $aBaseSlotDuration$, $aBaseSuperframeDuration$, and $aNumSuperframeSlots$ are reproduced here to assist the reader. No changes are made to these descriptions.

Table 51—MAC sublayer constants

Constant	Description	Value
$aBaseSlotDuration$	The number of symbols forming a superframe slot when the superframe order is equal to zero, as described in 5.1.1.1.	60
$aBaseSuperframeDuration$	The number of symbols forming a superframe when the superframe order is equal to zero.	$aBaseSlotDuration \times aNumSuperframeSlots$
$aNumSuperframeSlots$	The number of slots contained in any superframe.	16
$aUnitBackoffPeriod$	The number of symbols forming the basic time period used by the CSMA-CA algorithm.	20 For all PHYs except SUN PHYs operating in the 920 MHz band and the 950 MHz band, $aTurnaroundTime + aCCATime$. For SUN PHYs operating in the 920 MHz band or the 950 MHz band, $aTurnaroundTime + phyCCADuration$.

6.4.2 MAC PIB attributes

Change Table 52 (the entire table is not shown) as indicated:

Table 52—MAC PIB attributes

Attribute	Type	Range	Description	Default
<i>macSyncSymbolOffset</i> [†]	Integer	0x000–0x100 for the 2.4 GHz band 0x000–0x400 for the 868 MHz and 915 MHz bands, and the MR-FSK and MR-OFDM PHYs	The offset, measured in symbols, between the symbol boundary at which the MLME captures the timestamp of each transmitted or received frame, and the onset of the first symbol past the SFD, namely, the first symbol of the Length field.	Implementation specific
<i>macEnhancedBeaconOrder</i>	Integer	0–15	<u>Specification of how often the coordinator transmits an EB. If <i>macEnhancedBeaconOrder</i> = 15, no periodic EB will be transmitted.</u>	0
<i>macMPMIE</i>	Boolean	TRUE, FALSE	<u>An indication of whether the Coexistence Specification IE is to be included in the EB. If this value is TRUE, the EB will include the Coexistence Specification IE. If this value is FALSE, the EB will not include the Coexistence Specification IE. See Table 4j.</u>	FALSE
<i>macNBPANEnhancedBeaconOrder</i>	Integer	0–16383	<u>Specification of how often the coordinator transmits an EB in a nonbeacon-enabled PAN (i.e., <i>macBeaconOrder</i> = 15). If <i>macNBPANEnhancedBeaconOrder</i> = 16383, no EB will be transmitted.</u>	16383
<i>macOffsetTimeSlot</i>	Integer	1–15	<u>The offset between the start of the periodic beacon transmission and the start of the following EB transmission expressed in superframe time slots.</u>	15
<i>macFCSType</i>	Integer	0–1	<u>The type of the FCS. A value of zero indicates a 4-octet FCS, as specified in 5.2.1.9. A value of one indicates a 2-octet FCS, as specified in 5.2.1.9.</u> <u>This attribute is only valid for SUN PHYs.</u>	0

6.4.3 Calculating PHY dependent MAC PIB values

Change the first paragraph of 6.4.3 as indicated:

The read-only attribute *macAckWaitDuration* is dependent on a combination of constants and PHY PIB attributes. The PHY PIB attributes are listed in Table 71. The formula for relating the constants and attributes for all PHYs except the SUN PHYs is:

$$\begin{aligned} \textit{macAckWaitDuration} = \\ \textit{aUnitBackoffPeriod} + \textit{aTurnaroundTime} + \textit{phySHRDuration} + \text{ceiling}(6 \times \textit{phySymbolsPerOctet}) \end{aligned}$$

Insert the following new paragraphs after the first paragraph of 6.4.3:

The formula for relating the constants and attributes for the MR-FSK PHY is:

$$\begin{aligned} \textit{macAckWaitDuration} = \\ \textit{aUnitBackoffPeriod} + \textit{aTurnaroundTime} + \textit{phySHRDuration} + \text{ceiling}(9 \times \textit{phySymbolsPerOctet}) \end{aligned}$$

The formula for relating the constants and attributes for the MR-OFDM PHY is:

$$\begin{aligned} \textit{macAckWaitDuration} = \\ \textit{aUnitBackoffPeriod} + \textit{aTurnaroundTime} + \textit{phySHRDuration} + \textit{phyPHRDuration} + \text{ceiling}(6 \times \textit{phySymbolsPerOctet}) \end{aligned}$$

The formula for relating the constants and attributes for the MR-O-QPSK PHY is:

$$\begin{aligned} \textit{macAckWaitDuration} = \\ \textit{aUnitBackoffPeriod} + \textit{aTurnaroundTime} + \textit{phySHRDuration} + \textit{phyPHRDuration} + \textit{phyPSDUDuration}(\textit{LENGTH}) \end{aligned}$$

where LENGTH is the length, in octets, of the acknowledgment frame, and *phyPSDUDuration*(LENGTH) is given in 18.3.2.14.

8. General PHY requirements

8.1 General requirements and definitions

Insert the following items at the end of the second bulleted list in 8.1:

- **MR-FSK PHY:** multi-rate and multi-regional frequency shift keying (MR-FSK) PHY operating in multiple over-the-air data rates in support of SUN applications, as defined in 18.1.
- **MR-OFDM PHY:** multi-rate and multi-regional orthogonal frequency division multiplexing (MR-OFDM) PHY operating in multiple over-the-air data rates in support of SUN applications, as defined in 18.2.
- **MR-O-QPSK PHY:** multi-rate and multi-regional offset quadrature phase-shift keying (MR-O-QPSK) PHY operating in multiple over-the-air data rates in support of SUN applications, as defined in 18.3.

8.1.1 Operating frequency range

Insert the following new rows at the end of Table 66, and add the footnotes to the table as indicated:

Table 66—Frequency bands and data rates^a

PHY (MHz)	Frequency band (MHz)	Spreading parameters		Data parameters		
		Chip rate (kchip/s)	Modulation ^b	Bit rate (kb/s)	Symbol rate (ksymbol/s)	Symbols
169	169.400–169.475	—	Filtered 2FSK	4.8	4.8	Binary
			Filtered 2FSK	2.4	2.4	
			Filtered 4FSK	9.6	4.8	4-ary
450	450–470	—	Filtered 2FSK	4.8	4.8	Binary
			Filtered 4FSK	9.6	4.8	4-ary
470	470–510	—	Filtered 2FSK	50	50	Binary
				100	100	
			Filtered 4FSK	200	100	4-ary
		—	OFDM	As defined in 18.2		
		100	O-QPSK	6.25–50 (as defined in 18.3)	3.125	—
780	779–787	—	Filtered 2FSK	50	50	Binary
				100	100	
			Filtered 4FSK	200	100	4-ary
		—	OFDM	As defined in 18.2		
		1000	O-QPSK	31.25–500 (as defined in 18.3)	15.625	—

Table 66—Frequency bands and data rates^a (continued)

PHY (MHz)	Frequency band (MHz)	Spreading parameters		Data parameters		
		Chip rate (kchip/s)	Modulation ^b	Bit rate (kb/s)	Symbol rate (ksymbol/s)	Symbols
863	863–870	—	Filtered 2FSK	50	50	Binary
				100	100	
		—	OFDM	As defined in 18.2		
				Filtered 4FSK	200	100
868	868–870	100	O-QPSK	6.25–50 (as defined in 18.3)	3.125	—
896	896–901	—	Filtered 2FSK	10	10	Binary
				20	20	
				40	40	
901	901–902	—	Filtered 2FSK	10	10	Binary
				20	20	
				40	40	
915	902–928	—	Filtered 2FSK	50	50	Binary
			Filtered 2FSK	150	150	
			Filtered 2FSK	200	200	
		—	OFDM	As defined in 18.2		
				1000	O-QPSK	31.25–500 (as defined in 18.3)
917	917–923.5	—	Filtered 2FSK	50	50	Binary
			Filtered 2FSK	150	150	
			Filtered 2FSK	200	200	
		—	OFDM	As defined in 18.2		
				1000	O-QPSK	31.25–500 (as defined in 18.3)
920	920–928	—	Filtered 2FSK	50	50	Binary
			Filtered 2FSK	100	100	
			Filtered 2FSK	200	200	
			Filtered 4FSK	400		
		—	OFDM	As defined in 18.2		
				100	O-QPSK	6.25-50 (as defined in 18.3)

Table 66—Frequency bands and data rates^a (continued)

PHY (MHz)	Frequency band (MHz)	Spreading parameters		Data parameters		
		Chip rate (kchip/s)	Modulation ^b	Bit rate (kb/s)	Symbol rate (ksymbol/s)	Symbols
928	928–960 ^c	—	Filtered 2FSK	10	10	Binary
				20	20	
				40	40	
950	950–958	—	Filtered 2FSK	50	50	Binary
			Filtered 2FSK	100	100	
			Filtered 2FSK	200	200	
			Filtered 4FSK	400		
		—	OFDM	As defined in 18.2		
		100	O-QPSK	6.25–50 (as defined in 18.3)	3.125	—
1427	1427–1518 ^c	—	Filtered 2FSK	10	10	Binary
				20	20	
				40	40	
2450	2400–2483.5	—	Filtered 2FSK	50	50	Binary
			Filtered 2FSK	150	150	
			Filtered 2FSK	200	200	
		—	OFDM	As defined in 18.2		
		2000	O-QPSK	31.25–500 (as defined in 18.3)	15.625	—

^aData rates shown are over-the-air data rates.

^bSee 18.1.2 for more information on filtered FSK.

^cNoncontiguous.

8.1.2 Channel assignments

Insert the following new paragraphs after the last paragraph of 8.1.2:

The addition of the SUN PHY specifications requires a greater channel numbering capability. To address this issue, the definitions of channel pages nine and ten have been modified for the SUN PHYs to accommodate the larger number of channels, while maintaining consistency with the existing channel assignment schemes. See 8.1.2.10 for more information.

When *phyCurrentPage* is equal to nine or ten, *phyCurrentSUNPageEntry* shall specify the current frequency band, modulation scheme, and PHY mode of operation. The PIB attribute *phyNumSUNPageEntriesSupported* shall contain the number of SUN channel page entries supported, and *phySUNPageEntriesSupported* shall contain a complete list of the SUN channel page entries supported. The PHY PIB attributes are defined in 9.3.

8.1.2.1 Channel numbering for 780 MHz band

Insert the following new paragraph before the first paragraph of 8.1.2.1:

This subclause does not apply to the SUN PHY specifications. See 8.1.2.9 for an explanation of channel numbering for the SUN PHYs.

8.1.2.2 Channel numbering for 868 MHz, 915 MHz, and 2450 MHz bands

Insert the following new paragraph before the first paragraph of 8.1.2.2:

This subclause does not apply to the SUN PHY specifications. See 8.1.2.9 for an explanation of channel numbering for the SUN PHYs.

8.1.2.3 Channel numbering for 950 MHz PHYs

Insert the following new paragraph before the first paragraph of 8.1.2.3:

This subclause does not apply to the SUN PHY specifications. See 8.1.2.9 for an explanation of channel numbering for the SUN PHYs.

Insert the following new subclauses (8.1.2.9–8.1.2.10.2) after 8.1.2.8:

8.1.2.9 Channel numbering for SUN PHYs

The channel center frequency $ChanCenterFreq$ for all SUN PHYs, except the MR-O-QPSK PHY operating in the 868–870 MHz band, shall be derived as follows:

$$ChanCenterFreq = ChanCenterFreq_0 + NumChan \times ChanSpacing$$

where $ChanCenterFreq_0$ is the first channel center frequency in MHz, $ChanSpacing$ is the separation between adjacent channels in MHz, $NumChan$ is the channel number from 0 to $TotalNumChan-1$, and $TotalNumChan$ is the total number of channels for the available frequency band. The parameters $ChanSpacing$, $TotalNumChan$, and $ChanCenterFreq_0$ for different frequency bands and modulation schemes are specified in Table 68d.

Three channels are available for the MR-O-QPSK PHY operating in the 868–870 MHz band. The channel center frequency for each of these channels is shown in Table 68e.

8.1.2.10 Channel pages for SUN PHYs

Channel page nine is used to specify the standard-defined PHY operating modes, and channel page ten is used to specify the MR-FSK Generic-PHY-defined PHY modes. A device that implements more than one PHY operating mode, as described by channel page nine, may have multiple channel page nine entries in the $phySUNPageEntriesSupported$ table. The channels are defined by $phySUNChannelsSupported$. The PHY PIB attributes are defined in 9.3.

The structures of channel pages nine and ten are shown in Figure 64a.

8.1.2.10.1 Channel page structure for standard-defined PHY modes

Channel page nine specifies each standard-defined SUN PHY operating mode supported by the device.

Table 68d—Total number of channels and first channel center frequencies for SUN PHYs

Frequency band (MHz)	Modulation	ChanSpacing (MHz)	TotalNumChan	ChanCenterFreq ₀ (MHz)
169.400–169.475	MR-FSK operating mode #1 & #2 & #3	0.0125	6	169.40625
450–470	MR-FSK operating mode #1 & #2	0.0125	1599	450.00625
470–510	MR-FSK operating mode #1	0.2	199	470.2
	MR-FSK operating mode #2 & #3	0.4	99	470.4
	OFDM Option4	0.2	199	470.2
	O-QPSK	0.4	99	470.4
779–787	MR-FSK operating mode #1	0.2	39	779.2
	MR-FSK operating mode #2 & #3	0.4	19	779.4
	OFDM Option4	0.2	39	779.2
	OFDM Option3	0.4	19	779.4
	OFDM Option2	0.8	9	779.8
	OFDM Option1	1.2	6	780.2
	O-QPSK	2	4	780
863–870	MR-FSK operating mode #1	0.2	34	863.125
	MR-FSK operating mode #2 & #3	0.4	17	863.225
	OFDM Option4	0.2	34	863.125
	OFDM Option3	0.4	17	863.225
	OFDM Option2	0.8	8	863.425
	OFDM Option1	1.2	5	863.625
868–870	O-QPSK	As defined in Table 68e		
896–901	MR-FSK operating mode #1 ^a	0.0125	399	896.0125
	MR-FSK operating mode #2 ^b	0.0125	397	896.025
	MR-FSK operating mode #3 ^c	0.0125	393	896.05
901–902	MR-FSK operating mode #1 ^a	0.0125	79	901.0125
	MR-FSK operating mode #2 ^b	0.0125	77	901.025
	MR-FSK operating mode #3 ^c	0.0125	73	901.05

**Table 68d—Total number of channels and first channel center frequencies for SUN PHYs
(continued)**

Frequency band (MHz)	Modulation	ChanSpacing (MHz)	TotalNumChan	ChanCenterFreq ₀ (MHz)
902–928	MR-FSK operating mode #1	0.2	129	902.2
	MR-FSK operating mode #2 & #3	0.4	64	902.4
	OFDM Option4	0.2	129	902.2
	OFDM Option3	0.4	64	902.4
	OFDM Option2	0.8	31	902.8
	OFDM Option1	1.2	20	903.2
	O-QPSK	2	12	904
917–923.5	OFDM Option4	0.2	32	917.1
	OFDM Option3	0.4	16	917.3
	OFDM Option2	0.8	8	917.5
	OFDM Option1	1.2	5	917.9
	MR-FSK operating mode #1	0.2	32	917.1
	MR-FSK operating mode #2 & #3	0.4	16	917.3
	O-QPSK	2	3	918.1
920–928	MR-FSK operating mode #1	0.2	38	920.6
	MR-FSK operating mode #2	0.4	18	920.9
	MR-FSK operating mode #3 & #4	0.6	12	920.8
	OFDM Option4	0.2	39	920.2
	OFDM Option3	0.4	19	920.4
	OFDM Option2	0.8	9	920.8
	OFDM Option1	1.2	6	921.2
	O-QPSK	0.2	38	920.6
928–960	MR-FSK operating mode #1 ^a	0.0125	2559	928.0125
	MR-FSK operating mode #2 ^b	0.0125	2557	928.025
	MR-FSK operating mode #3 ^c	0.0125	2553	928.05
950–958	MR-FSK operating mode #1	0.2	33	951
	MR-FSK operating mode #2	0.4	16	951.1
	MR-FSK operating mode #3 & #4	0.6	11	951.2
	OFDM Option4	0.2	33	951
	OFDM Option3	0.4	16	951.1
	OFDM Option2	0.8	8	951.3
	O-QPSK	0.4	16	951.1

**Table 68d—Total number of channels and first channel center frequencies for SUN PHYs
(continued)**

Frequency band (MHz)	Modulation	ChanSpacing (MHz)	TotalNumChan	ChanCenterFreq ₀ (MHz)
1427–1518	MR-FSK operating mode #1 ^a	0.0125	7279	1427.0125
	MR-FSK operating mode #2 ^b	0.0125	7277	1427.025
	MR-FSK operating mode #3 ^c	0.0125	7273	1427.05
2400–2483.5	MR-FSK operating mode #1	0.2	416	2400.2
	MR-FSK operating mode #2 & #3	0.4	207	2400.4
	OFDM Option4	0.2	416	2400.2
	OFDM Option3	0.4	207	2400.4
	OFDM Option2	0.8	97	2400.8
	OFDM Option1	1.2	64	2401.2
	O-QPSK	5	16	2405

^aTwo adjacent *ChanSpacing*(s) are aggregated to form an overlapping channel with bandwidth of 25 kHz.

^bFour adjacent *ChanSpacing*(s) are aggregated to form an overlapping channel with bandwidth of 50 kHz.

^cEight adjacent *ChanSpacing*(s) are aggregated to form an overlapping channel with bandwidth of 100 kHz.

Table 68e—Center frequencies for the MR-O-QPSK PHY operating in the 868–870 MHz band

NumChan	ChanCenterFreq (MHz)
0	868.300
1	868.950
2	869.525

Channel page 9	Frequency band (Table 68f)	Modulation scheme = Filtered FSK (Table 68g)	List of FSK modes supported (Table 68h)	
		Modulation scheme = OFDM (Table 68g)	OFDM Option 1,2,3, or 4 (Table 68i)	MCS values supported (for selected Option) (Table 68j)
		Modulation scheme = O-QPSK (Table 68g)	Spreading mode (Table 68k)	Rate modes supported (Table 68k)
Channel page 10	MR-FSK Generic-PHY-defined PHY modes (as defined in 8.1.2.10.2)			

Figure 64a—Channel page structure for channel pages nine and ten

As shown in Figure 64a, channel page nine consists of the frequency band(s), modulation scheme(s), and PHY mode(s) to specify the SUN operating modes. The values used to define the frequency bands are the

frequency band identifiers shown in Table 68f. The values used to define the modulation schemes are shown in Table 68g. A device may support more than one standard-defined PHY mode.

Table 68f—SUN PHY frequency band definitions

Frequency band identifier	Frequency (MHz)	Designation
0	169.400–169.475 (Europe)	169 MHz band
1	450–470 (US FCC Part 22/90)	450 MHz band
2	470–510 (China)	470 MHz band
3	779–787 (China)	780 MHz band
4	863–870 (Europe)	863 MHz band
5	896–901 (US FCC Part 90)	896 MHz band
6	901–902 (US FCC Part 24)	901 MHz band
7	902–928 (US)	915 MHz band
8	917–923.5 (Korea)	917 MHz band
9	920–928 (Japan)	920 MHz band
10	928–960 (US, non-contiguous)	928 MHz band
11	950–958 (Japan)	950 MHz band
12	1427–1518 (US and Canada, non-contiguous)	1427 MHz band
13	2400–2483.5	2450 MHz band

Table 68g—SUN PHY modulation scheme representation

Modulation scheme identifier	Description
0	Filtered FSK
1	OFDM
2	O-QPSK
3	Reserved

The FSK modes supported for each of the supported frequency bands are defined in Table 68h. The operating modes for MR-FSK are defined in 18.1.2.

For the MR-OFDM PHY mode, the frequency band shall be set to one of the frequency bands identified in Table 66 for OFDM using the identifiers given in Table 68f. The OFDM option shall be set as indicated in Table 68i.

The MCS values-supported definition for the MR-OFDM PHY is defined in Table 68j.

For the MR-O-QPSK PHY mode, the allowed combinations of spreading modes, frequency bands, and PHY modes are defined in Table 68k.

Table 68h—FSK modes supported definition

Identifier	Description
0	Support for operating mode #1
1	Support for operating mode #2
2	Support for operating mode #3
3	Support for operating mode #4

Table 68i—OFDM option values for MR-OFDM PHY

Identifier	Option
0	1
1	2
2	3
3	4

Table 68j—MR-OFDM PHY MCS values supported

Identifier	Option 1	Option 2	Option 3	Option 4
0	MCS0	MCS0	MCS1	MCS2
1	MCS1	MCS1	MCS2	MCS3
2	MCS2	MCS2	MCS3	MCS4
3	MCS3	MCS3	MCS4	MCS5
4	Reserved	MCS4	MCS5	MCS6
5	Reserved	MCS5	MCS6	Reserved
6	Reserved	Reserved	Reserved	Reserved
7	Reserved	Reserved	Reserved	Reserved
8	Reserved	Reserved	Reserved	Reserved

Table 68k—Spreading mode and rate modes supported for MR-O-QPSK PHY

Band	Spreading mode	Chip rate (kchips/s)	Rate modes supported			
			Rate mode #3	Rate mode #2	Rate mode #1	Rate mode #0
470 MHz	DSSS	100	As defined in Table 166			
780 MHz	DSSS	1000	As defined in Table 166			
780 MHz	MDSSS	1000	As defined in Table 167			
868 MHz	DSSS	100	As defined in Table 166			

Table 68k—Spreading mode and rate modes supported for MR-O-QPSK PHY (continued)

Band	Spreading mode	Chip rate (kchips/s)	Rate modes supported			
			Rate mode #3	Rate mode #2	Rate mode #1	Rate mode #0
915 MHz	DSSS	1000	As defined in Table 166			
915 MHz	MDSSS	1000	As defined in Table 167			
917 MHz	DSSS	1000	As defined in Table 166			
917 MHz	MDSSS	1000	As defined in Table 167			
920 MHz	DSSS	100	As defined in Table 166			
950 MHz	DSSS	100	As defined in Table 166			
2450 MHz	DSSS	2000	As defined in Table 166			
2450 MHz	MDSSS	2000	As defined in Table 167			

8.1.2.10.2 Channel page structure for MR-FSK Generic PHY modes

For channel page ten, the available MR-FSK Generic-PHY-defined PHY modes are given by the *phySUNGenericPHYDescriptors* array, as described in Table 71 and Table 71a.

The structure of the MR-FSK Generic PHY descriptor is shown in Figure 64b. The *phySUNGenericPHYDescriptors* array consists of up to 16 MR-FSK Generic PHY descriptors. For an example of the use of the MR-FSK Generic PHY mechanism, refer to Annex K.

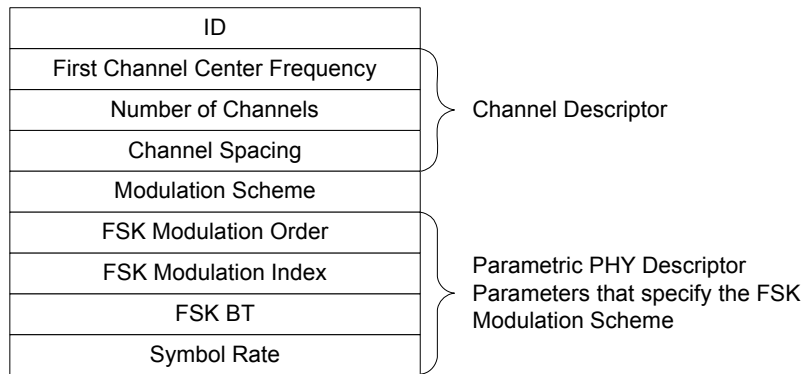

Figure 64b—MR-FSK Generic PHY descriptor

The Channel Descriptor consists of the following fields:

- First Channel Center Frequency is the center frequency, in hertz, of the lowest channel.
- Number of Channels is the number of contiguous channels starting at the first channel frequency.
- Channel Spacing is the spacing between adjacent channels in hertz.

The Modulation Scheme specifies the modulation method for the MR-FSK Generic PHY. The field indicates whether the modulation is FSK or Gaussian frequency shift keying (GFSK).

The Parametric PHY Descriptor fields associated with FSK are the following:

- FSK Modulation Order specifies the modulation order with 2-level or 4-level FSK defined.
- FSK Modulation Index specifies the modulation index ranging from 0.25 to 2.50.
- FSK BT is used only if the Modulation Scheme value is set to GFSK.
- Symbol Rate is the number of symbols per second transmitted over the air. The data rate can be derived from modulation order and symbol rate.

The bit-to-symbol mapping is specified in 18.1.2.2.

8.1.3 Minimum LIFS and SIFS periods

Change the first paragraph of 8.1.3 as indicated:

For all PHYs other than the UWB PHYs, the minimum LIFS period and SIFS period are:⁵

- *macLIFSPeriod* – 40 symbols
- *macSIFSPeriod* – 12 symbols

8.1.7 Receiver sensitivity definitions

Change Table 69 (the entire table is not shown) as indicated:

Table 69—Receiver sensitivity definitions

Term	Definition of term	Conditions
Receiver sensitivity	Lowest input power for which the PER conditions are met.	<ul style="list-style-type: none"> – PSDU length = <u>250 octets for SUN PHYs with data rates 50 kb/s and greater.</u> 20 octets <u>for all other PHYs.</u> – PER < 10% <u>for SUN PHYs.</u> – PER < 1% <u>for all other PHYs.</u> – Power measured at antenna terminals. – Interference not present.

Insert the following new subclause (8.1a) after 8.1.7:

8.1a Common signaling mode (CSM) for SUN PHY

The CSM is a common PHY mode specified to facilitate the multi-PHY management (MPM) scheme described in 5.1.13. A SUN device acting as a coordinator and with a duty cycle greater than 1% shall support CSM. The specification of CSM is given in Table 69a. The modulation and channel specification of CSM are given in 18.1.2.

The value of the SFD field, as described in 18.1.1.2, for CSM shall be that associated with a value of zero for the PIB attribute *phyMRFSKSFD*, as defined in 9.3.

⁵For the MR-OFDM PHY, the MAC symbol duration is defined in 5.1.

Table 69a—PHY Specification of the CSM for MPM scheme

Band (MHz)	Modulation	Modulation index	Channel spacing (kHz)	Data rate (kb/s)
470–510 779–787 863–870 902–928 917–923.5 920–928 950–958 2400–2483.5	Filtered 2FSK	1	200	50

8.2 General radio specifications

Insert the following new paragraph at the beginning of 8.2:

For the MR-FSK PHY, the meaning of a symbol duration for timing parameters is described in 5.1. For the MR-OFDM PHY, the meaning is described in 18.2. For the MR-O-QPSK PHY, the meaning is described in 18.3.2.14.

8.2.7 Clear channel assessment (CCA)

Insert the following new paragraph after the first paragraph of 8.2.7:

CCA mode 4 would typically be used in low duty cycle applications.

Change the third paragraph of 8.2.7 as indicated:

The PHY PIB attribute *phyCCAMode*, as described in 9.3, shall indicate the appropriate operation mode. The CCA parameters are subject to the following criteria:

- a) Except for the MR-O-QPSK PHY, the The ED threshold shall correspond to a received signal power of at most 10 dB greater than the specified receiver sensitivity for that PHY. For the MR-O-QPSK PHY, the ED threshold shall comply with the specification in 18.3.4.13.
- b) Except for the 920 MHz band PHYs and the 950 MHz band PHYs, the The CCA detection time shall be equal to *aCCATime*, as defined in Table 70. 8 symbol periods or For the 920 MHz band and the 950 MHz band PHYs, *phyCCADuration* symbol periods for the 950 MHz band PHY shall be used.

9. PHY services

9.2 PHY constants

Change Table 70 as indicated:

Table 70—PHY constants

Constant	Description	Value
<i>aMaxPHYPacketSize</i>	The maximum PSDU size (in octets) the PHY shall be able to receive.	<u>2047 for SUN PHYs</u> <u>127 for all other PHYs</u>
<i>aTurnaroundTime</i>	RX-to-TX or TX-to-RX turnaround time (in symbol periods), as defined in 8.2.1 and 8.2.2.	<u>For the SUN PHYs, the value is 1 ms expressed in symbol periods, rounded up to the next integer number of symbol periods using the ceiling() function.^a The value is 12 for all other PHYs.</u>
<i>aCCATime</i>	<u>The time required to perform CCA detection.</u>	<u>For the SUN PHYs other than MR-O-QPSK, the duration of 8 symbol periods, as defined in 5.1. For the MR-O-QPSK PHY, this value is defined in Table 188. For all other PHYs, the duration of 8 symbol periods.</u>
<i>aMRFSKPHRLength</i>	<u>The length of the PHR, in octets, for the MR-FSK PHY.</u>	<u>2</u>
<i>aMRFSKSFDLength</i>	<u>The length of the SFD, in octets, for the MR-FSK PHY.</u>	<u>2</u>
<i>aMROQPSKPHRLength</i>	<u>The length of the PHR, in octets, for the MR-O-QPSK PHY.</u>	<u>3</u>
<i>aMROQPSKSFDLength</i>	<u>The length of the SFD, in octets, for the MR-O-QPSK PHY.</u>	<u>2</u>

^aThe function ceiling() returns the smallest integer value greater than or equal to its argument value.

9.3 PHY PIB attributes

The first paragraph of 9.3 is reproduced here to assist the reader in understanding the notation used in Table 71. No changes are made to this paragraph.

The PHY PIB comprises the attributes required to manage the PHY of a device. The attributes contained in the PHY PIB are presented in Table 71. Attributes marked with a dagger (†) are read-only attributes (i.e., attribute can only be set by the PHY), which can be read by the next higher layer using the MLME-GET.request primitive. All other attributes can be read or written by the next higher layer using the MLME-GET.request or MLME-SET.request primitives, respectively.

Change Table 71 (the entire table is not shown) as indicated. The entries for `phyChannelsSupported`, `phyCurrentPage`, `phyMaxFrameDuration`, and `phySHRDuration` are reproduced here to assist the reader. No changes are made to these entries:

Table 71—PHY PIB attributes

Attribute	Type	Valid range	Description
<code>phyCurrentChannel</code>	Integer	As defined in 8.1.2.	The RF logical channel to use for all following transmissions and receptions, 8.1.2.
<code>phyChannelsSupported</code> [†]	List of channel descriptions	—	Each entry in the list consists of a channel page and a list of channel numbers supported for that channel page.
<code>phyCurrentPage</code>	Integer	Any valid channel page	This is the current PHY channel page. This is used in conjunction with <code>phyCurrentChannel</code> to uniquely identify the channel currently being used.
<code>phyMaxFrameDuration</code> [†]	Integer	—	The maximum number of symbols in a frame, as defined in 9.4.
<code>phySHRDuration</code> [†]	Integer	PHY dependent	The duration of the synchronization header (SHR) in symbols for the current PHY.
<code>phyCCADuration</code>	Integer	0–1000	The duration for CCA, specified in symbols. This attribute shall only be implemented with PHYs operating in <u>the 920 MHz band or the 950 MHz band</u> .
<code>phyCCATimeMethod</code>	Integer	0, 1	<u>This parameter determines how to calculate the time required to perform CCA detection for devices operating in the 920 MHz band or the 950 MHz band. A value of zero indicates that CCA detection time = symbol duration × phyCCADuration. A value of one indicates that CCA detection time = 2^{phyCCADuration}. CCA detection time is given in μs.</u>
<code>phySymbolsPerOctet</code> [†]	Float	0.4, 1.3, 1.6, 2, 4, 5.3, 8	The number of symbols per octet for the current PHY. For the UWB PHY this is defined in 14.2.3. For CSS PHY, 1.3 corresponds to 1 Mb/s, while 5.3 corresponds to 250 kb/s. <u>For the MR-OFDM PHY, see 18.2.3.3.</u> <u>This attribute is not used by the MR-O-OPSK PHY.</u>
<code>phyFSKFECEnabled</code>	Boolean	TRUE, FALSE	<u>A value of TRUE indicates that FEC is turned on. A value of FALSE indicates that FEC is turned off.</u> <u>This attribute is only valid for the MR-FSK PHY.</u>
<code>phyFSKFECInterleavingRSC</code>	Boolean	TRUE, FALSE	<u>A value of TRUE indicates that interleaving is enabled for RSC. A value of FALSE indicates that interleaving is disabled for RSC.</u> <u>This attribute is only valid for the MR-FSK PHY.</u>

Table 71—PHY PIB attributes (continued)

Attribute	Type	Valid range	Description
<i>phyFSKFECScheme</i>	Integer	0, 1	A value of zero indicates that a nonrecursive and nonsystematic code (NRNSC) is employed. A value of one indicates that a recursive and systematic code (RSC) is employed. See 18.1.2.4 for more information on FEC. This attribute is only valid for the MR-FSK PHY.
<i>phySUNChannelsSupported</i> [†]	List of channels	=	The list of channel numbers supported when <i>phyCurrentPage</i> = 7 or 8.
<i>phyMaxSUNChannel-Supported</i> [†]	Integer	0–65 535	The maximum channel number supported by the device. This attribute is only valid if <i>phyCurrentPage</i> equals 7 or 8.
<i>phyNumSUNPageEntries-Supported</i>	Integer	0–63	The number of SUN channel page entries supported by the device.
<i>phySUNPageEntries-Supported</i>	List of SUN PHY modes	As shown in Figure 64a	Each entry in the list contains the description of a frequency band, modulation scheme, and particular PHY mode implemented by the device. In the case of the channel page 9 entries, there may only be one entry for any given frequency band/modulation scheme pair. If the Generic PHY mechanism is supported, there is only one channel page 10 entry.
<i>phyCurrentSUNPageEntry</i>	SUN PHY mode	As shown in Figure 64a	Defines the current frequency band, modulation scheme, and particular PHY mode when <i>phyCurrentPage</i> = 7 or 8.
<i>phySUNNumGenericPHY-Descriptors</i>	Integer	0–16	The number of GenericPHYDescriptor entries supported by the device, as described in Table 71a.
<i>phySUNGenericPHY-Descriptors</i>	Array	An array sized by <i>phySUNNumGenericPHYDescriptors</i> . The size of each element is per the GenericPHYDescriptor entry, as described in Table 71a.	A table of GenericPHYDescriptor entries, where each entry is used to define a channel page 10 PHY mode.
<i>phyNumModeSwitchParameterEntries</i>	Integer	0–4	The number of current entries in <i>phyModeSwitchParameterEntries</i> .

Table 71—PHY PIB attributes (*continued*)

Attribute	Type	Valid range	Description
<u><i>phyModeSwitchParameterEntries</i></u>	<u>Array</u>	<u>RxS array of ModeSwitchDescriptor entries. R ranges from 1 to 4. S contains the elements of ModeSwitchDescriptor entry in Table 71b.</u>	<p>An array of up to four rows, where each row consists of a set of ModeSwitchDescriptor entries.</p> <p>This attribute is only valid for the MR-FSK PHY.</p>
<u><i>phyFSKPreambleLength</i></u>	<u>Integer</u>	<u>4–1000</u>	<p>The number of 1-octet patterns, as described in 18.1.1.1, in the preamble.</p> <p>This attribute is only valid for the MR-FSK PHY.</p>
<u><i>phyMRFKSFDF</i></u>	<u>Integer</u>	<u>0, 1</u>	<p>Determines which group of SFDs is used, as described in Table 131.</p> <p>This attribute is only valid for the MR-FSK PHY.</p>
<u><i>phyFSKScramblePSDU</i></u>	<u>Boolean</u>	<u>TRUE or FALSE</u>	<p>A value of FALSE indicates that data whitening of the PSDU is disabled. A value of TRUE indicates that data whitening of the PSDU is enabled.</p> <p>This attribute is only valid for the MR-FSK PHY.</p>
<u><i>phyOFDMInterleaving</i></u>	<u>Integer</u>	<u>0, 1</u>	<p>A value of zero indicates an interleaving depth of one symbol. A value of one indicates an interleaving depth of the number of symbols equal to the frequency domain spreading factor (SF).</p> <p>This attribute is only valid for the MR-OFDM PHY.</p>
<u><i>phyPHRDURATION</i></u>	<u>Integer</u>	<u>3, 4, 6, 8, or 15</u>	<p>The duration of the PHR, in symbols, for the current PHY.</p> <p>If the <u><i>phyOFDMInterleaving</i></u> attribute is zero, this attribute has a value of three for OFDM Option 1 and a value of six for OFDM Options 2, 3, and 4. If the <u><i>phyOFDMInterleaving</i></u> attribute is one, this attribute has a value of four for OFDM Option 1, a value of eight for OFDM Option 2, and a value of six for OFDM Options 3 and 4. For the MR-O-QPSK PHY, this attribute has a value of fifteen.</p> <p>This attribute is only valid for the MR-OFDM PHY and MR-O-QPSK PHY.</p>

Insert the following new tables (Table 71a, Table 71b) after Table 71:

Table 71a—Elements of GenericPHYDescriptor

Name	Type	Valid range	Description
GenericPHYID	Integer	0–15	The identifier of the MR-FSK Generic PHY mode. This ID corresponds to a bit position (0–15) in the channel page 10 channel page definition, as defined in 8.1.2.10.2.
FirstChannelCenterFrequency	Integer	1–2 485 000 000	Specifies the center frequency, in hertz, of the first channel in the list.
NumberOfChannels	Integer	0–65 535	The number of channels defined for the particular PHY mode. The actual channels supported by the device are defined by <i>phySUNChannelsSupported</i> .
ChannelSpacing	Integer	1–4 000 000	The distance between adjacent channel center frequencies in hertz.
ModulationScheme	Integer	0–3	The modulation scheme of the MR-FSK Generic PHY entry. This parameter can take one of the following values: 0 = FSK 1 = GFSK 2–3 = reserved The remaining parameters in this table are determined based on the value of the ModulationScheme parameter.
FSKModulationOrder	Integer	0–3	The modulation order if the value of the ModulationScheme parameter is 0 or 1. This parameter can take one of the following values: 0 = 2-level 1 = 4-level 2–3 = reserved
FSKModulationIndex	Float	0.25–2.50 (step size of 0.05)	The modulation index if the value of the ModulationScheme parameter is zero or one.
FSKBT	Integer	0–3	The BT value if the value of the ModulationScheme parameter is one. This parameter can take one of the following values: 0 = BT is 0.5 1 = BT is 1.0 2–3 = reserved
SymbolRate	Integer	1–2 000 000	The symbol rate in symbols per second.

Table 71b—Elements of ModeSwitchDescriptor

Name	Type	Valid range	Description
SettlingDelay	Integer	0–510	The settling delay, in μs , between the end of the final symbol of the PPDU initiating the mode switch and the start of the PPDU transmitted using the new PHY mode.
SecondaryFSKPreambleLength	Integer	0–16	The number of 1-octet patterns, as described in 18.1.1.1, in the secondary preamble if the new mode is MR-FSK. This parameter does not apply if the new mode is MR-OFDM or MR-O-QPSK
SecondaryFSKSFD	Boolean	TRUE or FALSE	If the new mode is MR-FSK, a value of TRUE indicates that a secondary SFD is transmitted. A value of FALSE indicates that a secondary SFD is not transmitted. This parameter does not apply if the new mode is MR-OFDM or MR-O-QPSK.

9.4 PHY PIB attribute values for *phyMaxFrameDuration* and *phySHRDuration*

Change the first paragraph of 9.4 as shown:

For PHYs other than CSS, ~~and UWB,~~ and the SUN PHYs, the attribute *phyMaxFrameDuration* is given by:

Insert the following three new paragraphs after the fourth paragraph of 9.4:

For the MR-FSK PHY, assuming uncoded frames, the attribute *phyMaxFrameDuration* is given by:

$$phyMaxFrameDuration = phySHRDuration + (aMRFSKPHRLength + aMaxPHYPacketSize) \times phySymbolsPerOctet$$

For the MR-OFDM PHY, the attribute *phyMaxFrameDuration* is dependent on the attribute *phyOFDMInterleaving*. If *phyOFDMInterleaving* = 0,

$$phyMaxFrameDuration = phySHRDuration + phyPHRDuration + ceiling[(aMaxPHYPacketSize + 1) \times phySymbolsPerOctet]$$

If *phyOFDMInterleaving* = 1,

$$phyMaxFrameDuration = phySHRDuration + phyPHRDuration + SF \times ceiling[(aMaxPHYPacketSize + 1) \times (phySymbolsPerOctet / SF)]$$

For the MR-O-QPSK PHY, the attribute *phyMaxFrameDuration* is defined in 18.3.2.14.

Change the last paragraph of 9.4 as indicated:

For PHYs other than the SUN PHYs, the PHY PIB attribute *phySHRDuration* is given by:

Insert the following three new paragraphs after the last paragraph of 9.4:

For the MR-FSK PHY, the attribute *phySHRDuration* is given by:

$$phySHRDuration = phySymbolsPerOctet \times (phyFSKPreableLength + aMRFSKSFDLength)$$

For the MR-O-QPSK PHY, the attribute *phySHRDuration* is defined in 18.3.2.14.

For the MR-OFDM PHY, the attribute *phySHRDuration* has the value six.

Insert after Clause 17 the following new clause (Clause 18):

18. SUN PHYs

Three PHYs are specified in order to support SUN applications: multi-rate and multi-regional frequency shift keying (MR-FSK), as described in 18.1, multi-rate and multi-regional orthogonal frequency division multiplexing (MR-OFDM), as described in 18.2, and multi-rate and multi-regional offset quadrature phase-shift keying (MR-O-QPSK), as described in 18.3.

A SUN device shall support the MR-FSK PHY, allowing MPM signaling utilizing the CSM.

18.1 MR-FSK PHY specification

The multi-rate and multi-regional frequency shift keying (MR-FSK) PHY is described in 18.1.1 through 18.1.5.

18.1.1 PDU format for MR-FSK

The MR-FSK PDU shall support the format shown in Figure 112 and may support the format shown in Figure 113 if mode switch is enabled.

The synchronization header (SHR), PHY header (PHR), and PHY payload components are treated as bit strings of length n , numbered b_0 on the left and b_{n-1} on the right. When transmitted, they are processed b_0 first to b_{n-1} last, without regard to their content or structure.

All reserved fields shall be set to zero upon transmission and shall be ignored upon reception.

		Octets	
		2	Variable
Preamble	SFD	As defined in 18.1.1.3	PSDU
SHR		PHR	PHY payload

Figure 112—Format of the MR-FSK PDU (without mode switch)

		Octets	
		2	
Preamble	SFD	As defined in 18.1.1.4	
SHR		PHR	

Figure 113—Format of the MR-FSK mode switch PDU

18.1.1.1 Preamble field

The Preamble field shall contain *phyFSKPreambleLength* (as defined in 9.3) multiples of the 8-bit sequence “01010101” for filtered 2FSK. The Preamble field shall contain *phyFSKPreambleLength* multiples of the 16-bit sequence “0111 0111 0111 0111” for filtered 4FSK.

18.1.1.2 SFD

The SFD for filtered 2FSK shall be a 2-octet sequence selected from the list of values shown in Table 131. The SFD for filtered 4FSK shall be a 4-octet sequence selected from the list of values shown in Table 132. Devices that do not support FEC shall support the SFD associated with uncoded (PHR + PSDU) and a value of zero for the PIB attribute *phyMRFSSKSF*, as defined in 9.3; these devices may also support the SFD associated with uncoded (PHR + PSDU) and a value of one for the PIB attribute *phyMRFSSKSF*. Devices that support FEC shall support both SFDs associated with a value of zero for the PIB attribute *phyMRFSSKSF*; these devices may additionally support both SFDs associated with a value of one for the PIB attribute *phyMRFSSKSF*.

The SFD is transmitted starting from the leftmost bit (i.e., starting with b_0).

Table 131—MR-FSK PHY SFD values for filtered 2FSK

	SFD value for coded (PHR + PSDU) (b_0 – b_{15})	SFD value for uncoded (PHR + PSDU) (b_0 – b_{15})
<i>phyMRFSSKSF</i> = 0	0110 1111 0100 1110	1001 0000 0100 1110
<i>phyMRFSSKSF</i> = 1	0110 0011 0010 1101	0111 1010 0000 1110

Table 132—MR-FSK PHY SFD values for filtered 4FSK

	SFD value for coded (PHR + PSDU) (b_0 – b_{31})	SFD value for uncoded (PHR + PSDU) (b_0 – b_{31})
<i>phyMRFSSKSF</i> = 0	0111 1101 1111 1111 0111 0101 1111 1101	1101 0111 0101 0101 0111 0101 1111 1101
<i>phyMRFSSKSF</i> = 1	0111 1101 0101 1111 0101 1101 1111 0111	0111 1111 1101 1101 0101 0101 1111 1101

18.1.1.3 PHR (without mode switch)

The format of the PHR is shown in Figure 114. All multi-bit fields are unsigned integers and shall be processed MSB first.

The Mode Switch field (MS) shall be set to zero, indicating that the entire packet shall be transmitted at a single data rate and using a single modulation scheme.

The FCS Type field (FCS) indicates the length of the FCS field described in 5.2.1.9 that is included in the MPDU. Table 133 shows the relationship between the contents of the FCS Type field and the length of the transmitted FCS.

Bit string index	0	1–2	3	4	5–15
Bit mapping	MS	R_1 – R_0	FCS	DW	L_{10} – L_0
Field name	Mode Switch	Reserved	FCS Type	Data Whitening	Frame Length

Figure 114—Format of the PHR (without mode switching) for MR-FSK

Table 133—Relationship between FCS Type field and transmitted FCS length

FCS Type field value	Transmitted FCS length
0	4-octets
1	2-octets

The Data Whitening field (DW) indicates whether data whitening of the PSDU is used upon transmission. When data whitening is used, the Data Whitening field shall be set to one. It shall be set to zero otherwise. Data whitening shall not be applied to the SHR or PHR.

The Frame Length field (L_{10} – L_0) specifies the total number of octets contained in the PSDU (prior to FEC encoding, if enabled). The most significant bit (leftmost) shall be transmitted first.

18.1.1.4 PHR for the mode switch packet

The format of the PHR is shown in Figure 115. All multi-bit fields are unsigned integers and shall be processed MSB first.

Bit string index	0	1–2	3	4–10	11–14	15
Bit mapping	MS	M_1 – M_0	FEC	As defined in Figure 116	B_3 – B_0	PC
Field name	Mode Switch	Mode Switch Parameter Entry	New Mode FEC	New Mode	Checksum	Parity Check

Figure 115—Format of the PHR for MR-FSK mode switching

The Mode Switch field (MS) shall be set to one, indicating that a mode switch shall occur. The mode of the next PPDU transmitted (i.e., the new mode PPDU) shall be as described by the remaining fields contained in the PHR in Figure 115. If the new mode is MR-FSK, the new mode PPDU is the same as Figure 112 except that the preamble and SFD are optional. For MR-OFDM, the new mode PPDU has the same format as Figure 128. If the new mode is MR-O-QPSK, the new mode PPDU is the same as Figure 140.

The Mode Switch Parameter Entry field (M_1 – M_0) is the index of the entry in the *phyModeSwitchParameterEntries* array, as described in Table 71, that defines the mode switch parameters to be used, as described in Table 71b. If the Mode Switch Parameter Entry field indicates an unsupported entry in the *phyModeSwitchParameterEntries* array of the receiver, the receiver shall discard the packet and remain in the present PHY mode.

The New Mode FEC field (FEC) specifies whether the packet following the mode switch PPDU is transmitted using FEC. A value of zero indicates that the new mode packet is transmitted without FEC, and a value of one indicates that it is transmitted with FEC. If the new mode packet has an SFD and, therefore, packet coding information, as described in 18.1.2.4, the SFD shall override the value of the New Mode FEC field.

The New Mode field is formatted as shown in Figure 116. The format of the new mode PPDU is determined by the New Mode field. The Page field (PAGE) shall be set to zero to indicate channel page nine or set to one to indicate channel page ten. The Modulation Scheme field (MOD₁–MOD₀) indicates the modulation scheme, as described in Table 68g, when *phyCurrentChannel* (as defined in 9.3) equals seven; when *phyCurrentChannel* equals eight, the Modulation Scheme field shall be set to zero upon transmission and ignored upon reception. The Mode field (MD₃–MD₀) specifies the new mode of operation. When the Page field is zero (channel page nine), the interpretation of the Mode field (MD₃–MD₀) is based on the modulation scheme:

- If the modulation scheme is filtered FSK, the integer value of MD₃–MD₀ is the integer value of the specific FSK mode in the FSK modes supported bitmap, as described in Figure 64a.
- If the modulation scheme is not filtered FSK, the bits (MD₃–MD₀) shall be set to zero upon transmission and ignored upon reception. The corresponding data rates are specified in the PHR of the new mode PPDU.

When the Page field is one (channel page ten), the Mode field selects one element (0–15) in the *phySUNGenericPHYDescriptors* (as defined in 9.3), and the new PHY mode is defined by the MR-FSK Generic PHY mechanism.

Bit string index	4	5–6	7–10
Bit mapping	PAGE	MOD ₁ –MOD ₀	MD ₃ –MD ₀
Field name	Page	Modulation Scheme	Mode

Figure 116—Format of the New Mode field

The Checksum field (B₃–B₀) is the checksum for the BCH(15,11) code. The generator polynomial for the Bose Chaudhuri Hocquenghem (BCH) code is as follows:

$$G(x) = 1 + x + x^4 .$$

The Parity Check (PC) field provides error detection for the mode switch PPDU. Its value is calculated from the following equation:

$$PC = MS \oplus M_0 \oplus M_1 \oplus FEC \oplus PAGE \oplus MOD_0 \oplus MOD_1 \oplus MD_0 \oplus MD_1 \oplus MD_2 \oplus MD_3$$

where \oplus is modulo-2 addition (addition over GF(2)). The combination of the BCH(15,11) code and one parity bit allows for the achievement of single error correction and double error detection over the 11 bits of information in the mode switch PPDU.

If the receiving device receives a PHR with the MS field set to one, it first performs the BCH calculation over the first 11 bits of the PHR. If the resulting checksum is valid, and the MS field is still set to one after error correction, a parity check using the PC field is performed. If the result of the parity check is valid, the

receiving device processes the mode switch and decodes the subsequent PPDU. If the result of the parity check is invalid, or if the MS field is set to zero after the error correction, the receiver terminates the receive procedure.

18.1.1.5 PSDU field

The PSDU field carries the data of the PPDU.

18.1.2 Modulation and coding for MR-FSK

The modulation for the MR-FSK PHY is either a 2- or a 4-level filtered FSK that meets the transmit spectral mask, as defined in 18.1.5.6. GFSK with a BT value of 0.5 should be used in the 920 MHz band and the 950 MHz band.

Table 134 shows the modulation and channel parameters for the standard-defined PHY operating modes for the 169 MHz, 450 MHz, 470 MHz, 863 MHz, 896 MHz, 901 MHz, 915 MHz, 928 MHz, 1427 MHz, and 2450 MHz bands. A device shall support operating mode #1 and may additionally support operating modes #2 and #3.

Table 134—MR-FSK modulation and channel parameters^a

Frequency band (MHz)	Parameter	Operating mode #1	Operating mode #2	Operating mode #3
169.400–169.475 (Europe)	Data rate (kb/s)	4.8	2.4	9.6
	Modulation	Filtered 2FSK	Filtered 2FSK	Filtered 4FSK
	Modulation index	0.5	2.0	0.33
	Channel spacing (kHz)	12.5	12.5	12.5
450–470 (U.S. FCC Part 22/90)	Data rate (kb/s)	9.6	4.8	—
	Modulation	Filtered 4FSK	Filtered 2FSK	—
	Modulation index	0.33	1.0	—
	Channel spacing (kHz)	12.5	12.5	—
470–510 (China)	Data rate (kb/s)	50	100	200
	Modulation	Filtered 2FSK	Filtered 2FSK	Filtered 4FSK
	Modulation index	1.0	1.0	0.33
	Channel spacing (kHz)	200	400	400
779–787 (China)	Data rate (kb/s)	50	100	200
	Modulation	Filtered 2FSK	Filtered 2FSK	Filtered 4FSK
	Modulation index	1.0	1.0	0.33
	Channel spacing (kHz)	200	400	400

Table 134—MR-FSK modulation and channel parameters^a (continued)

Frequency band (MHz)	Parameter	Operating mode #1	Operating mode #2	Operating mode #3
863–870 (Europe)	Data rate (kb/s)	50	100	200
	Modulation	Filtered 2FSK	Filtered 2FSK	Filtered 4FSK
	Modulation index	1.0	1.0	0.33
	Channel spacing (kHz)	200	400	400
896–901 (U.S. FCC Part 90)	Data rate (kb/s)	10	20	40
	Modulation	Filtered 2FSK	Filtered 2FSK	Filtered 2FSK
	Modulation index	0.5	0.5	0.5
	Channel spacing (kHz)	12.5	12.5	12.5
901–902 (U.S. FCC Part 24)	Data rate (kb/s)	10	20	40
	Modulation	Filtered 2FSK	Filtered 2FSK	Filtered 2FSK
	Modulation index	0.5	0.5	0.5
	Channel spacing (kHz)	12.5	12.5	12.5
902–928 (U.S. ISM)	Data rate (kb/s)	50	150	200
	Modulation	Filtered 2FSK	Filtered 2FSK	Filtered 2FSK
	Modulation index	1.0	0.5	0.5
	Channel spacing (kHz)	200	400	400
917–923.5 (Korea)	Data rate (kb/s)	50	150	200
	Modulation	Filtered 2FSK	Filtered 2FSK	Filtered 2FSK
	Modulation index	1.0	0.5	0.5
	Channel spacing (kHz)	200	400	400
928–960 ^b (U.S. FCC Part 22/24/90/101)	Data rate (kb/s)	10	20	40
	Modulation	Filtered 2FSK	Filtered 2FSK	Filtered 2FSK
	Modulation index	0.5	0.5	0.5
	Channel spacing (kHz)	25	25	25
1427–1518 ^b (U.S. FCC Part 90)/ (Canada SRSP 301.4)	Data rate (kb/s)	10	20	40
	Modulation	Filtered 2FSK	Filtered 2FSK	Filtered 2FSK
	Modulation index	0.5	0.5	0.5
	Channel spacing (kHz)	25	25	25
2400–2483.5 (Worldwide)	Data rate (kb/s)	50	150	200
	Modulation	Filtered 2FSK	Filtered 2FSK	Filtered 2FSK
	Modulation index	1.0	0.5	0.5
	Channel spacing (kHz)	200	400	400

^aData rates shown are over-the-air data rates (the data rate transmitted over the air regardless of whether the FEC is enabled).

^bNoncontiguous.

Table 135 shows the modulation and channel parameters for the standard-defined PHY operating modes for the 920 MHz and the 950 MHz Japanese bands. For these bands, a device shall support both operating modes #1 and #2 and may additionally support operating modes #3 and #4.

Table 135—MR-FSK modulation and channel parameters for Japanese band^a

Frequency band (MHz)	Parameter	Operating mode #1	Operating mode #2	Operating mode #3	Operating mode #4
920–928 (Japan)	Data rate (kb/s)	50	100	200	400
	Modulation	Filtered 2FSK	Filtered 2FSK	Filtered 2FSK	Filtered 4FSK
	Modulation index	1.0	1.0	1.0	0.33
	Channel spacing (kHz) ^b	200	400	600	600
950–958 (Japan)	Data rate (kb/s)	50	100	200	400
	Modulation	Filtered 2FSK	Filtered 2FSK	Filtered 2FSK	Filtered 4FSK
	Modulation index	1.0	1.0	1.0	0.33
	Channel spacing (kHz) ^b	200	400	600	600

^aData rates shown are over-the-air data rates (the data rate transmitted over the air regardless of whether the FEC is enabled).

^bChannel separation of 200 kHz is used. Channel spacing shows bundling of 200 kHz channels.

In addition to the standard-defined PHY operating modes, the MR-FSK PHY may support an MR-FSK Generic PHY mechanism, which enables the use of a broader set of data rates and PHY parameters to describe a PHY mode. The set of PHY operating mode parameters is defined by the MR-FSK Generic PHY Descriptor, as described in 8.1.2.10.2 and Table 71a. An example of the MR-FSK Generic PHY mechanism is given in Annex K.

18.1.2.1 Reference modulator diagram

The functional block diagram in Figure 117 is provided as a reference for specifying the MR-FSK PHY data flow processing functions. The subclause number in each block refers to the subclause that describes that function. Each bit shall be processed using the bit order rules defined in 18.1.1.

When FEC is enabled, the PHR and PSDU shall be processed for coding as a single block of data, as described in 18.1.2.4. When data whitening is enabled, the scrambling shall be only applied over the PSDU, as described in 18.1.3.

All fields in the PPDU shall use the same symbol rate and modulation order, unless otherwise specified elsewhere in this standard.

18.1.2.2 Bit-to-symbol mapping

The nominal frequency deviation, Δf , shall be

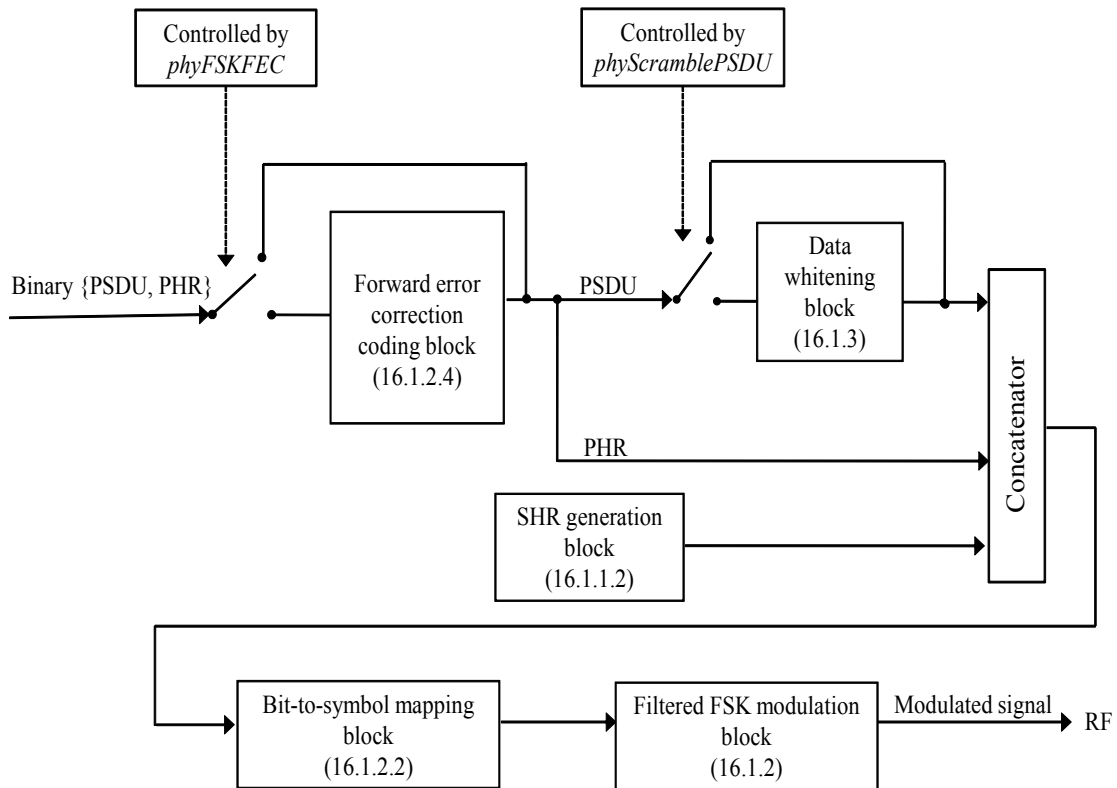

Figure 117—MR-FSK FEC, data whitening, and modulator functions

$$\left(\frac{\text{symbol rate} \times \text{modulation index}}{2} \right)$$

The symbol encoding for both filtered 2-level and 4-level FSK modulation is shown in Table 136, where the frequency deviation, f_{dev} , is equal to Δf for filtered 2FSK and is equal to $3 \times \Delta f$ for filtered 4FSK. For filtered 4FSK modulation, two bits shall be mapped to four frequency deviation levels for the PHR and PSDU. The SHR shall be encoded in the lowest ($-f_{\text{dev}}$) and the highest ($+f_{\text{dev}}$) frequency deviations. The symbol rate shall be the same for the entire PPDU.

18.1.2.3 Modulation quality

Modulation quality shall be measured by observing the frequency deviation tolerance and the zero crossing tolerance of the eye diagram caused by a PN9 sequence of length 511 bits.

18.1.2.3.1 Frequency deviation tolerance

Modulation frequency tolerance is measured as a percentage of the frequency deviation, f_{dev} , dictated by the modulation index. In the case of filtered 2FSK, the measured frequency deviation, f , at $T_s / 2$ shall be constrained to the range $70\% f_{\text{dev}} < |f| < 130\% f_{\text{dev}}$, as shown in Figure 118, where T_s is the symbol time. In the case of filtered 4FSK, the measured frequency deviation, f , at $T_s / 2$ shall be constrained to the range $8\% f_{\text{dev}} < |f| < 58\% f_{\text{dev}}$ for the inner levels and $75\% f_{\text{dev}} < |f| < 125\% f_{\text{dev}}$ for the outer levels, as shown in Figure 119.

Table 136—MR-FSK symbol encoding

2-level	
Symbol (binary)	Frequency deviation
0	$-f_{\text{dev}}$
1	$+f_{\text{dev}}$
4-level	
Symbol (binary)	Frequency deviation
01	$-f_{\text{dev}}$
00	$-f_{\text{dev}} / 3$
10	$+f_{\text{dev}} / 3$
11	$+f_{\text{dev}}$

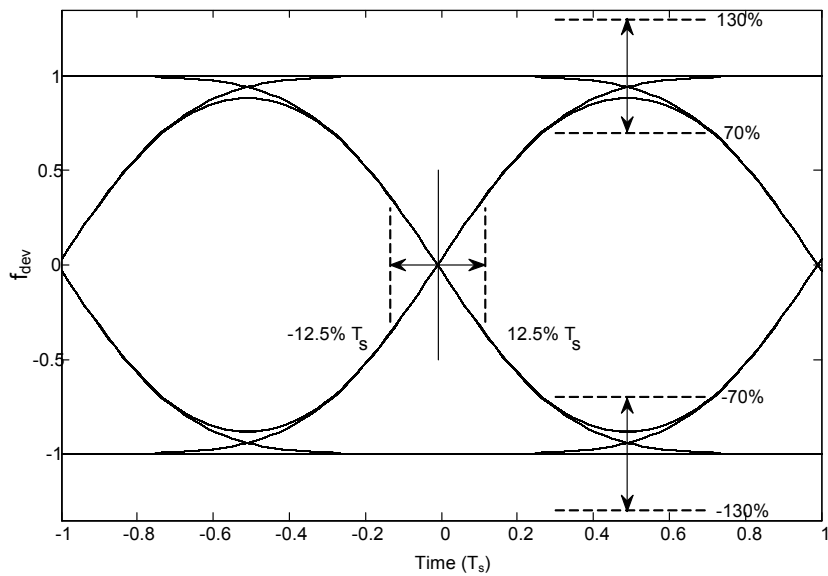

Figure 118—Eye diagram for filtered 2FSK

18.1.2.3.2 Zero crossing tolerance

In the case of filtered 2FSK, the excursions for the zero crossings for all trajectories of the eye diagram shall be constrained to within $\pm 12.5\%$ of the symbol time T_s , as shown in Figure 118. In the case of filtered 4FSK, the excursions for the zero crossings for all trajectories of the eye diagram shall be constrained to within $\pm 30\%$ of the symbol time T_s , as shown in Figure 119.

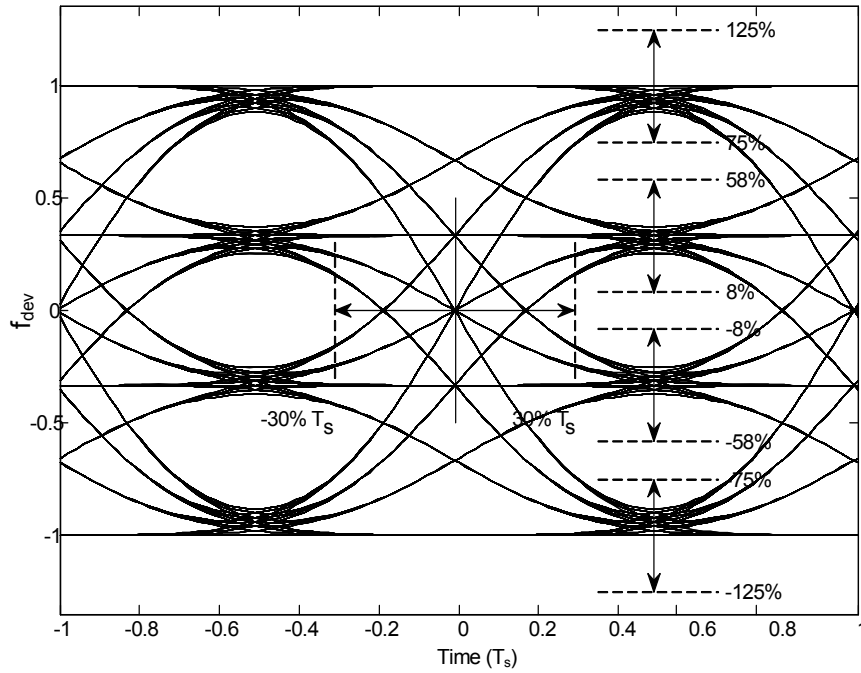

Figure 119—Eye diagram for filtered 4FSK

18.1.2.4 Forward error correction (FEC)

FEC is optional. If the SFD indicates that FEC is used, as described in Table 131, then the FEC is applied to the PHR and PSDU as a single block of data.

Two types of FEC may be applied: a recursive and systematic code (RSC) or a nonrecursive and nonsystematic code (NRNSC). The use of RSC or NRNSC coding shall be controlled by the PIB attribute *phyFSKFECScheme*, as defined in 9.3.

When the SFD value indicates a coded packet, FEC shall be employed on the PHR and PSDU bits, applying either a 1/2-rate systematic or nonsystematic convolution coding with constraint length $K = 4$, and using the following two generator polynomials:

$$G_0(x) = 1 + x + x^2 + x^3$$

$$G_1(x) = 1 + x^2 + x^3$$

The total number of bits to be encoded, N , is obtained by summing up the size of the PHR (L_{PHR}), the length of the PSDU (L_{PSDU} is equal to the content of the Frame Length field in Figure 114), the number of tail bits (L_{TAIL}), and the number of padding bits (L_{PAD}). N shall be computed as follows:

$$N = L_{PHR} + L_{PSDU} + L_{TAIL} + L_{PAD} \tag{5}$$

Note that L_{PSDU} is zero in the case of a mode switch packet.

Immediately after encoding the PHR and PSDU, a termination sequence with length $L_{TAIL} = 3$ bits shall be inserted into the encoder, as shown in Figure 120. The tail bits are required to return the encoder to the zero state.

PHR	PSDU	Tail bits ($T_0 T_1 T_2$)
-----	------	--------------------------------

Figure 120—Data block extension with tail bits prior to coding

The value of the tail bits are dependent on the coding scheme and shall be set as shown in Table 137.

Table 137—Tail bit pattern for the RSC and NRNSC encoders

Memory state (M_0 – M_2)	Tail bits	
	RSC ($T_0 T_1 T_2$)	NRNSC ($T_0 T_1 T_2$)
000	000	000
001	100	000
010	110	000
011	010	000
100	111	000
101	011	000
110	001	000
111	101	000

When interleaving is used in conjunction with convolutional coding, a padding sequence of L_{PAD} bits shall be further inserted into the encoder immediately after the tail bits. The padding bits are required to fill up the last interleaver buffer completely, as described in 18.1.2.5. L_{PAD} shall be computed as follows:

$$L_{PAD} = 5, \text{ when } \frac{L_{PHR} + L_{PSDU}}{8} \text{ is odd}$$

$$L_{PAD} = 13, \text{ when } \frac{L_{PHR} + L_{PSDU}}{8} \text{ is even}$$

Padding bit patterns should not contain a long series of ‘1’s or ‘0’s. Figure 121 and Figure 122 illustrate examples of such patterns. The RSC encoder is shown in Figure 123, and the NRNSC encoder is shown in Figure 124.

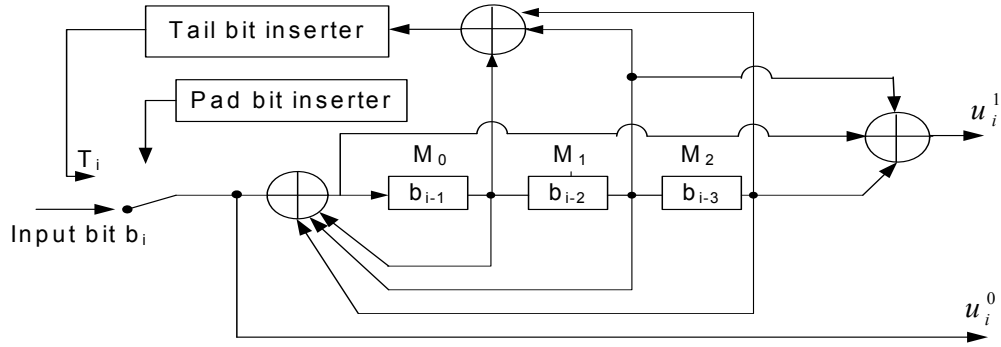

Figure 123—The recursive and systematic code (RSC) encoder

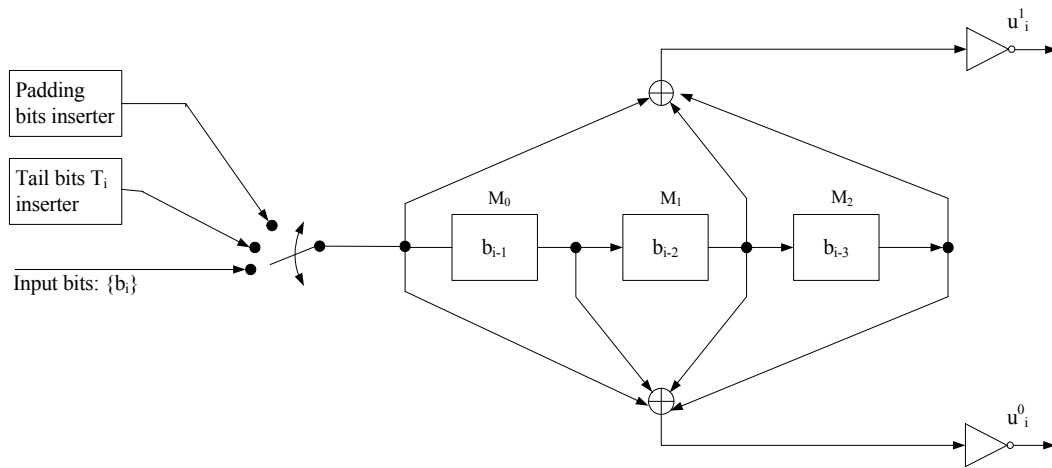

Figure 124—Non-recursive and non-systematic code (NRNSC) encoder

PHR	PSDU	Tail bits ($T_0 T_1 T_2$)	5-bit padding pattern 01011
-----	------	--------------------------------	--------------------------------

Figure 121—An example of extension with padding bits prior to encoding, when $(L_{PHR} + L_{PSDU})/8$ is odd

PHR	PSDU	Tail bits ($T_0 T_1 T_2$)	13-bit padding pattern 0 1011 0000 1011
-----	------	--------------------------------	--

Figure 122—An example of extension with padding bits prior to encoding, when $(L_{PHR} + L_{PSDU})/8$ is even

For an input sequence of bits with length N , $B = \{b_i, i \in [0, 1, 2, \dots, N-1]\}$, the i th input bit shall be represented as b_i and be fed into memory state M_0 , M_1 , and M_2 in that order. The tail bits T_i and the pad bits shall be inserted once the encoding of PHR and PSDU is complete. The output sequence S also comprises N code-symbols.

$$S = \{s(0), s(1), s(2), \dots, s(N-1)\} = \{u_0^1, u_0^0, \dots, u_i^1, u_i^0, u_{i+1}^1, u_{i+1}^0, \dots, u_{N-1}^1, u_{N-1}^0\}$$

Each code-symbol is denoted by $s(i) = \{u_i^1, u_i^0\}$, for all $i = 0, \dots, N-1$, where $s(i)$ is the i th output code-symbol due to the i th input bit and u_i^1 and u_i^0 indicate the first and second output bits of the convolutional encoder, respectively. The code-symbol $s(i)$ shall precede the code-symbol $s(i+1)$ and the code bit u_i^1 shall precede the code bit u_i^0 .

For the RSC encoder, the first and the second output bits of the encoder shall be generated in the following way:

$$u_i^1 = b_i \oplus (b_{i-1} \oplus b_{i-2} \oplus b_{i-3}) \oplus b_{i-2} \oplus b_{i-3}$$

$$u_i^0 = b_i$$

where \oplus stands for modulo-2 addition.

For the NRNSC encoder, the first and the second output bits of the encoder shall be generated in the following way:

$$u_i^1 = \overline{b_i \oplus b_{i-2} \oplus b_{i-3}}$$

$$u_i^0 = \overline{b_i \oplus b_{i-1} \oplus b_{i-2} \oplus b_{i-3}}$$

where the “overline” indicates the complement of the modulo-2 addition.

18.1.2.5 Code-symbol interleaving

Interleaving of code-bits shall be employed in conjunction with NRNSC coding, in order to improve robustness against burst errors and to break correlation of consecutive bits. Interleaving may also be employed with RSC coding. In the case of RSC coding, the use of the interleaver is controlled by the PIB attribute *phyFSKFECInterleavingRSC*, as defined in 9.3. No interleaving shall be employed if FEC is not enabled. The interleaver is defined by a permutation of code-symbols, where each permuted element contains exactly one code-symbol, i.e., a pair of two bits, as described in 18.1.2.4. The process of interleaving is illustrated in Figure 125.

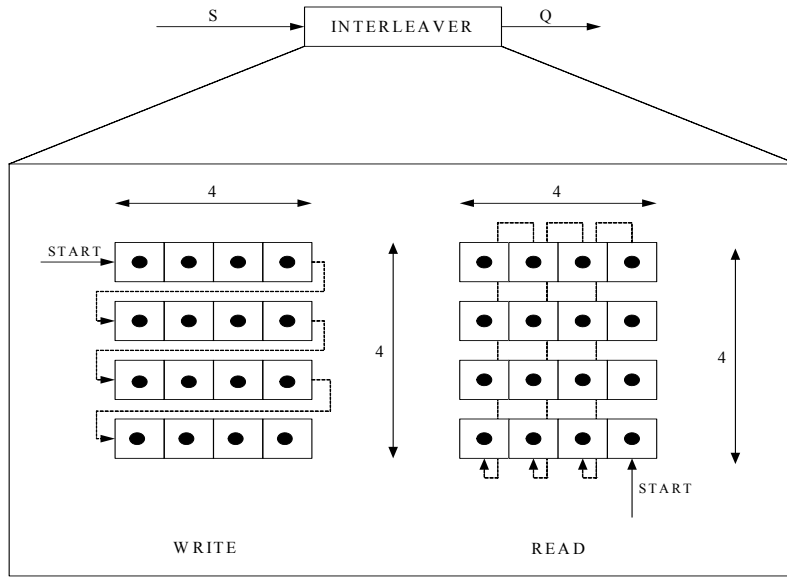

Figure 125—The interleaving block

The complete sequence of code-symbols $S = \{s(i)\}$, $0 \leq i \leq N-1$, is passed to the interleaver as N_{BLOCK} consecutive subsequences $A^{(p)}$, where $0 \leq p \leq N_{BLOCK}-1$, $N_{BLOCK} = N/16$, and N is a nonzero integer multiple of 16, as described in Equation (5). The subsequence $A^{(0)}$ shall be passed to the interleaver first in time, and the subsequence $A^{(N_{BLOCK}-1)}$ shall be passed to the interleaver last in time.

Each subsequence $A^{(p)} = \{a^{(p)}(j)\}$ contains exactly 16 code-symbols and shall be derived according to the following equation:

$$a^{(p)}(j) = s(p \times 16 + j)$$

where

$$0 \leq j \leq 15$$

For each subsequence $A^{(p)}$ passed to the interleaver, the corresponding subsequence $Q^{(p)} = \{q^{(p)}(k)\}$ exiting the interleaver shall be computed as follows:

$$q^{(p)}(k) = a^{(p)}(t)$$

where

$$0 \leq k \leq 15$$

$$t = 15 - 4 \times (k \bmod 4) - \left\lfloor \frac{k}{4} \right\rfloor$$

The function $\lfloor x \rfloor = \text{floor}(x)$ returns the largest integer value not greater than x .

The complete sequence of interleaved code-symbols is derived as $Q = \{Q^{(0)}, Q^{(1)}, \dots, Q^{(N_{BLOCK}-1)}\}$.

18.1.3 Data whitening for MR-FSK

Support for data whitening is optional.

When data whitening is enabled at the transmitter, the Data Whitening field of the PHR shall be set to one, as described in 18.1.1.3, and the whitened data shall be the exclusive or (XOR) of the PSDU with the PN9 sequence, as described by the following equation:

$$E_n = R_n \oplus \text{PN9}_n$$

where

- E_n is the whitened bit
- R_n is the data bit being whitened
- PN9_n is the PN9 sequence bit

For each packet transmitted with data whitening enabled, R_0 is the first bit of the PSDU and the index n increments for subsequent bits of the PSDU.

For packets received with the Data Whitening field of the PHR set to one, the receiver decodes the scrambled data in the following way:

$$R_n = RE_n \oplus \text{PN9}_n$$

where

- R_n is the PSDU bit after de-whitening
- RE_n is the PSDU bit at the output of the filtered FSK demodulator

The PN generator is defined by the schematic in Figure 126.

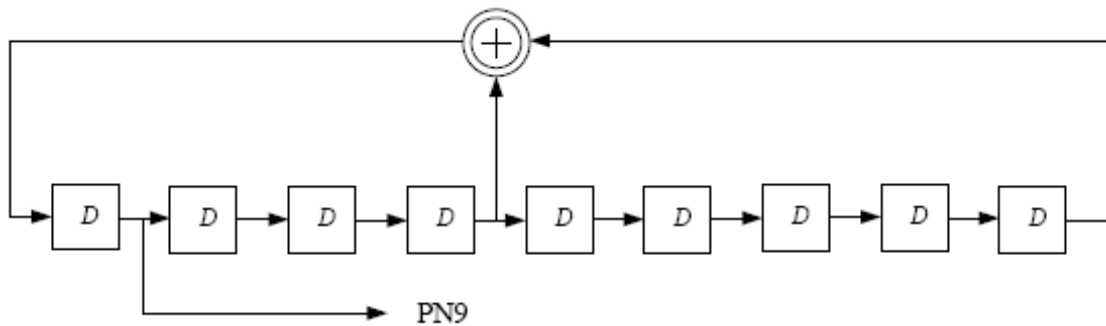

Figure 126—Schematic of the PN9 sequence generator

The seed in the PN9 generator shall be all ones: “11111111.” The PN9 generator shall be reinitialized to the seed after each packet (either transmit or receive).

The PN9 generator is clocked using the seed as the starting point and enabled after the first clock cycle. For example, the first 30 bits out of the PN9 generator, once it is enabled, would be as follows:

$$\text{PN9}_n = 0_0, 0_1, 0_2, 0_3, 1_4, 1_5, 1_6, 1_7, 0_8, 1_9, 1_{10}, 1_{11}, 0_{12}, 0_{13}, 0_{14}, 0_{15}, 1_{16}, 0_{17}, 1_{18}, 1_{19}, 0_{20}, 0_{21}, 1_{22}, 1_{23}, 0_{24}, 1_{25}, 1_{26}, 0_{27}, 1_{28}, 1_{29}$$

18.1.4 Mode switch mechanism for MR-FSK

The mode switch mechanism is optional.

The mode switch mechanism is enabled by setting the Mode Switch field to one. The MR-FSK mode switch PPDU is transmitted on *phyCurrentChannel*, as defined in 9.3, and the PPDU containing the PSDU is transmitted on the channel that corresponds to the same center frequency used for the MR-FSK mode switch PPDU. When an MR-FSK mode switch PPDU, as described in Figure 113, is received, a device that supports mode switching shall change its mode of operation to the new mode defined in the MR-FSK mode switch PPDU, in order to receive the following packet.

When changing from the current operating mode to the new mode, a settling delay may exist. If the modulation scheme of the new mode is FSK, the settling delay shall be in the range of zero to 100 μ s. If the modulation scheme of the new mode is not FSK, the settling delay shall be in the range of 200 μ s to 500 μ s. The settling delay value is part of a ModeSwitchDescriptor, as described in Table 71b. The value specified in the Mode Switch Parameter Entry field of the PHR, as described in Figure 115, is the index of the PIB attribute array *phyModeSwitchParameterEntries*, as defined in 9.3, which contains the elements of the ModeSwitchDescriptor. How the Mode Switch Parameter Entry field maps to ModeSwitchDescriptor is exemplified in Table 138. For the mode switch operation of FSK->FSK, the symbol rate is changed. For the mode switch operation of FSK->4FSK, the modulation order and/or the symbol rate is changed. The Mode Switch Parameter Entry table may be defined by the next higher layer.

Table 138—An example of mapping between *phyModeSwitchParameterEntries*[] and ModeSwitchDescriptor

<i>phyModeSwitchParameterEntries</i> []	Mode Switch Operation (Source mode -> Target mode)	ModeSwitchDescriptor		
		Settling Delay (μ s)	SecondaryFSK Preamble Length	Secondary FSKSFD
0	FSK->FSK	20	0	FALSE
1	FSK->4FSK	40	0	FALSE
2	FSK->OFDM	160	n/a	n/a
3	FSK->O-QPSK	80	n/a	n/a

Transmission of the new mode PPDU shall start SettlingDelay from the end of the mode switch PPDU. The SettlingDelay shall be the value indicated in the Mode Switch Parameter Entry field in the mode switch PPDU. The reception and rejection of the following packet follows the same mechanism described in 5.1.6.2. When the new mode PPDU has been received, the receiver shall return to the mode specified by *phyCurrentSUNPageEntry*, as defined in 9.3, within a SIFS or LIFS period based on the symbol duration of the new mode PPDU, depending on the received frame length, as described in 5.1.1.3. If the transmission of an ACK is requested by the transmitter, the ACK is transmitted using the PHY mode specified by *phyCurrentSUNPageEntry*.

The sequence of the MR-FSK mode switch PPDU, the optional settling delay, and the PPDU transmitted in the new PHY mode is shown in Figure 127.

Devices employing the mode switch mechanism shall meet the MAC timing requirements of 5.1.1.1.1 and 5.1.1.1.2, using the symbol duration of the PHY mode prior to the mode switch.

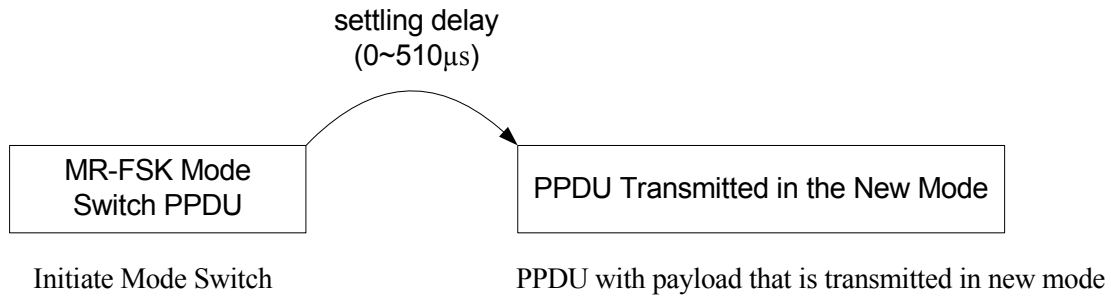

Figure 127—Transmitting sequence between MR-FSK mode switch PPDUs and the new mode PPDUs

The frequency band is not changed by the PHY mode switch mechanism. The center frequency of the channel is also not changed by a PHY mode switch, and channel center frequency alignment between the various modulation schemes support the mode switch mechanism. For example, the channel frequency alignment for the 915 MHz band is shown in Table 139.

Table 139—Channel alignment for 915 MHz band

FSK or OFDM (200 kHz channel spacing)	FSK or OFDM (400 kHz channel spacing)	OFDM (800 kHz channel spacing)	O-QPSK
902.2	—	—	—
902.4	902.4	—	—
902.6	—	—	—
902.8	902.8	902.8	—
903.0	—	—	—
903.2	903.2	—	—
903.4	—	—	—
903.6	903.6	903.6	—
903.8	—	—	—
904.0	904.0	—	904.0
904.2	—	—	—
904.4	904.4	904.4	—
904.6	—	—	—
904.8	904.8	—	—
905.0	—	—	—
905.2	905.2	905.2	—
905.4	—	—	—
905.6	905.6	—	—
905.8	—	—	—

Table 139—Channel alignment for 915 MHz band (continued)

FSK or OFDM (200 kHz channel spacing)	FSK or OFDM (400 kHz channel spacing)	OFDM (800 kHz channel spacing)	O-QPSK
906.0	906.0	906.0	906.0
906.2	—	—	—
906.4	906.4	—	—
906.6	—	—	—
906.8	906.8	906.8	—
907.0	—	—	—
907.2	907.2	—	—
907.4	—	—	—
907.6	907.6	907.6	—
907.8	—	—	—
908.0	908.0	—	908.0
908.2	—	—	—
908.4	908.4	908.4	—
908.6	—	—	—
908.8	908.8	—	—
909.0	—	—	—
909.2	909.2	909.2	—
909.4	—	—	—
909.6	909.6	—	—
909.8	—	—	—
910.0	910.0	910.0	910.0
⋮	⋮	⋮	⋮
etc.	etc.	etc.	etc.

18.1.5 MR-FSK PHY RF requirements**18.1.5.1 Operating frequency range**

The MR-FSK PHY operates in the bands given in Table 134 and Table 135.

18.1.5.2 Regulatory compliance

It is the responsibility of the implementer to verify and ensure that the device is in compliance with all regulatory requirements in the geographic region where the device is deployed or sold. Conformance with this standard does not guarantee compliance with the relevant regulatory requirements that may apply.

18.1.5.3 Radio frequency tolerance

The single-sided clock frequency tolerance T at the transmitter, in ppm, shall be as follows:

$$T \leq \min\left(\frac{T_0 \times R \times h \times F_0}{R_0 \times h_0 \times F}, 50 \text{ ppm}\right)$$

for all combinations of R , h , and F and for each mode supported by the device, where

R is the symbol rate in ksymbol/s

h is the modulation index

F is the carrier frequency in MHz

R_0 is 50 ksymbol/s

h_0 is 1

F_0 is 915 MHz

T_0 is 30 ppm for modes in all bands, except at 2450 MHz for which the value of T_0 is 40 ppm

18.1.5.4 Channel switch time

Channel switch time shall be less than or equal to 500 μ s. The channel switch time is defined as the time elapsed when changing to a new channel, including any required settling time.

18.1.5.5 Transmitter symbol rate

The transmitter symbol rate tolerance shall be less than or equal to ± 300 ppm. The peak transmitter symbol rate jitter shall be less than or equal to ± 40 ppm. Transmitted packets shall have symbol rates within the specified symbol rate tolerance, and all symbols within the packet shall be within the symbol rate tolerance relative to the average symbol rate of all the symbols in the packet. The symbol rate jitter is measured as the standard deviation of symbol edges from the nominal symbol edge position for the symbol rate used by the transmitter.

18.1.5.6 Transmit spectral mask

The transmit spectral content is the ratio of the total transmitted out-of-channel power to the total transmitted in-channel power in a given integration bandwidth.

The integration bandwidth shall be equal to $1.5 \times R$, where R is the symbol rate, expressed in units of hertz.

Out-of-channel power shall be measured at two offset frequencies relative to the carrier frequency. The offset frequencies M_1 and M_2 are defined as follows:

$$M_1 = 1.5 \times R \times (1 + h)$$

$$M_2 = 3 \times R \times (1 + h)$$

where h is the modulation index for 2-level modulation and three times the modulation index for 4-level modulation.

The transmit spectral content at M_1 and M_2 shall be less than -25 dB and -35 dB, respectively.

The modulated signal shall use a PN data pattern of 511 bits or longer.

The spectrum analyzer settings for this measurement shall be as follows: the resolution bandwidth is 1 kHz, the video bandwidth is 1 kHz or greater, and the detector is RMS.

18.1.5.7 Receiver sensitivity

The MR-FSK receiver sensitivity shall be better than S , where S , for binary modulation, is defined as follows:

$$S = \left(S_0 + 10 \log \left[\frac{R}{R_0} \right] \right) \text{ dBm}$$

where

- S_0 is -91 without FEC and -97 with FEC
- R_0 is 50 kb/s
- R is the bit rate in kb/s

See 8.1.7 for additional information on receiver sensitivity.

18.1.5.8 Receiver interference rejection

The adjacent designated channels are those on either side of the desired designated channel that are closest in frequency to the desired designated channel. The alternate designated channel is more than one removed from the desired designated channel in the operational frequency band.

The adjacent channel rejection shall be measured as follows: the desired signal shall be a compliant MR-FSK PHY signal, as defined in 18.1.2, of pseudo-random data at the center frequency of the desired channel. The desired signal is input to the receiver at a level 3 dB above the receiver sensitivity given in 18.1.5.7.

In either the adjacent or the alternate channel, an unmodulated carrier in the center of that channel is input at the following level relative to the level of the desired signal:

- The adjacent channel rejection shall be greater than or equal to 10 dB.
- The alternate channel rejection shall be greater than or equal to 30 dB.

The test shall be performed for only one interfering signal at a time. The receiver shall meet the error rate criteria defined in 8.1.7 under these conditions.

18.1.5.9 Tx-to-Rx turnaround time

The MR-FSK PHY shall meet the requirements for TX-to-RX turnaround time as defined in 8.2.1.

18.1.5.10 Rx-to-Tx turnaround time

The MR-FSK PHY shall meet the requirements for RX-to-TX turnaround time as defined in 8.2.2.

18.1.5.11 Transmit power

A transmitter shall be capable of transmitting at least -3 dBm. Devices should transmit lower power when possible in order to reduce interference to other devices and systems.

The maximum transmit power is limited by local regulatory bodies.

18.1.5.12 Receiver maximum input level of desired signal

The MR-FSK PHY shall have a receiver maximum input level greater than or equal to -20 dBm using the measurement defined in 8.2.4.

18.1.5.13 Receiver ED

The MR-FSK PHY shall provide the receiver ED measurement as described in 8.2.5.

18.1.5.14 Link quality indicator

The MR-FSK PHY shall provide the LQI measurement as described in 8.2.6.

18.1.5.15 Clear channel assessment (CCA)

The MR-FSK PHY shall use one of the CCA methods as described in 8.2.7.

18.2 MR-OFDM PHY specification

The multi-rate and multi-regional orthogonal frequency division multiplexing (MR-OFDM) PHY is RF band agnostic and supports data rates ranging from 50 kb/s to 800 kb/s. The subcarrier spacing is constant and is equal to $10416\frac{2}{3}$ Hz (or $31250\frac{3}{3}$ Hz).

The symbol rate is $8\frac{1}{3}$ ksymbol/s, which corresponds $(\frac{4}{5}) \times (31250\frac{3}{3})$ or 120 μ s per symbol. This symbol includes a quarter-duration cyclic prefix (CP; 24 μ s) and a base symbol (96 μ s).

This PHY includes four options, each one being characterized by the number of active tones during the PHR or PSDU. The total signal bandwidth for each option ranges from 1.2 MHz down to <200 kHz.

While the standard does not specify the actual DFT size implemented in the system, the standard does support the following baseline DFT size: 128, 64, 32, and 16.

Two examples of encoding a packet for the MR-OFDM PHY are given in Annex L and Annex M.

18.2.1 PPDU format for MR-OFDM

The MR-OFDM PPDU shall be formatted as illustrated in Figure 128.

The synchronization header (SHR), PHY header (PHR), and PHY payload components are treated as bit strings of length n , numbered b_0 on the left and b_{n-1} on the right. When transmitted, they are processed b_0 first to b_{n-1} last, without regard to their content or structure.

All reserved fields shall be set to zero upon transmission and shall be ignored upon reception.

Definitions are provided in the frequency domain for the Short Training field (STF) in 18.2.1.1 and for the Long Training field (LTF) in 18.2.1.2. In each case, a normative set of operations is specified to transform the frequency domain fields to the time domain and to insert prescribed repetitions or CPs of these time domain sequences.

The DATA field is composed of the PSDU, tail bits, and pad bits, as described in 18.2.3.4. The PPDU Tail Bit field (TAIL) is described in 18.2.3.9. The method for adding pad bits (PAD) is described in 18.2.3.10.

		Number of OFDM Symbols			
		Variable	Variable	6 bits	Variable
STF	LTF	As defined in 18.2.1.3	PSDU	TAIL	PAD
SHR		PHR	PHY payload		

Figure 128—Format of the MR-OFDM PPDU

18.2.1.1 Short Training field (STF)

Subclauses 18.2.1.1.1 through 18.2.1.1.4 describe the STF.

18.2.1.1.1 Frequency domain STF

The STF for the four scalable bandwidth OFDM options are defined by the following four tables. Table 140 shows the frequency domain representation of the STF for Option 1. The scaling factor used in the table is $\sqrt{104/12}$.

Table 140—Frequency domain representation of Option 1 STF_freq(0)

Tone#	Value	Tone#	Value	Tone#	Value	Tone#	Value
−64	0	−32	−2.9439	0	0	32	2.9439
−63	0	−31	0	1	0	33	0
−62	0	−30	0	2	0	34	0
−61	0	−29	0	3	0	35	0
−60	0	−28	0	4	0	36	0
−59	0	−27	0	5	0	37	0
−58	0	−26	0	6	0	38	0
−57	0	−25	0	7	0	39	0
−56	0	−24	2.9439	8	2.9439	40	−2.9439
−55	0	−23	0	9	0	41	0
−54	0	−22	0	10	0	42	0
−53	0	−21	0	11	0	43	0
−52	0	−20	0	12	0	44	0
−51	0	−19	0	13	0	45	0
−50	0	−18	0	14	0	46	0
−49	0	−17	0	15	0	47	0
−48	−2.9439	−16	2.9439	16	−2.9439	48	2.9439
−47	0	−15	0	17	0	49	0
−46	0	−14	0	18	0	50	0

Table 140—Frequency domain representation of Option 1 STF_freq(0) (continued)

Tone#	Value	Tone#	Value	Tone#	Value	Tone#	Value
-45	0	-13	0	19	0	51	0
-44	0	-12	0	20	0	52	0
-43	0	-11	0	21	0	53	0
-42	0	-10	0	22	0	54	0
-41	0	-9	0	23	0	55	0
-40	-2.9439	-8	2.9439	24	2.9439	56	0
-39	0	-7	0	25	0	57	0
-38	0	-6	0	26	0	58	0
-37	0	-5	0	27	0	59	0
-36	0	-4	0	28	0	60	0
-35	0	-3	0	29	0	61	0
-34	0	-2	0	30	0	62	0
-33	0	-1	0	31	0	63	0

Table 141 shows the frequency domain representation of the STF for Option 2. The scaling factor used in the table is $\sqrt{52/12}$.

Table 141—Frequency domain representation of Option 2 STF_freq(1)

Tone#	Value	Tone#	Value	Tone#	Value	Tone#	Value
-32	0	-16	-2.0817	0	0	16	2.0817
-31	0	-15	0	1	0	17	0
-30	0	-14	0	2	0	18	0
-29	0	-13	0	3	0	19	0
-28	0	-12	2.0817	4	2.0817	20	-2.0817
-27	0	-11	0	5	0	21	0

Table 141—Frequency domain representation of Option 2 STF_freq(1) (continued)

Tone#	Value	Tone#	Value	Tone#	Value	Tone#	Value
–26	0	–10	0	6	0	22	0
–25	0	–9	0	7	0	23	0
–24	–2.0817	–8	2.0817	8	–2.0817	24	2.0817
–23	0	–7	0	9	0	25	0
–22	0	–6	0	10	0	26	0
–21	0	–5	0	11	0	27	0
–20	–2.0817	–4	2.0817	12	2.0817	28	0
–19	0	–3	0	13	0	29	0
–18	0	–2	0	14	0	30	0
–17	0	–1	0	15	0	31	0

Table 142 shows the frequency domain representation of the STF for Option 3. The scaling factor used in the table is sqrt(26/6).

Table 142—Frequency domain representation of Option 3 STF_freq(2)

Tone#	Value	Tone#	Value	Tone#	Value	Tone#	Value
–16	0	–8	2.0817	0	0	8	2.0817
–15	0	–7	0	1	0	9	0
–14	0	–6	0	2	0	10	0
–13	0	–5	0	3	0	11	0
–12	2.0817	–4	2.0817	4	–2.0817	12	–2.0817
–11	0	–3	0	5	0	13	0
–10	0	–2	0	6	0	14	0
–9	0	–1	0	7	0	15	0

Table 143 shows the frequency domain representation of the STF for Option 4. The scaling factor used in the table is sqrt(14/6).

18.2.1.1.2 Time domain STF generation

Given a sequence of N samples $f(n)$, indexed by $n = 0, \dots, N - 1$, the discrete Fourier transform (DFT) is defined as $F(k)$, where $k = 0, \dots, N - 1$:

$$F(k) = \frac{1}{\sqrt{N}} \sum_{n=0}^{N-1} f(n) e^{-j2\pi kn/N}$$

Table 143—Frequency domain representation of Option 4 STF_freq(3)

Tone#	Value	Tone#	Value	Tone#	Value	Tone#	Value
−8	0	−4	1.5275	0	0	4	1.5275
−7	0	−3	0	1	0	5	0
−6	1.5275	−2	1.5275	2	−1.5275	6	−1.5275
−5	0	−1	0	3	0	7	0

The sequence $f(n)$ can be calculated from $F(k)$ using the inverse discrete Fourier transform (IDFT), where the k values numbered from 0 to $(N/2) - 1$ correspond to tones numbered from 0 to $(N/2) - 1$ and the k values numbered from $(N/2)$ to $(N - 1)$ correspond to tones numbered from $-(N/2)$ to -1 , respectively:

$$f(n) = \frac{1}{\sqrt{N}} \sum_{k=0}^{N-1} F(k) e^{j2\pi nk/N}$$

The time domain STF for Option- n ($n = 1, 2, 3, 4$) is obtained as follows:

$$\text{STF_time}(\text{Option-}n) = \text{IDFT}(\text{STF_freq}(\text{Option-}n))$$

The CP is then prepended to the OFDM symbol.

18.2.1.1.3 Time domain STF repetition

There are four STF OFDM symbols, and the last 1/2 of the fourth OFDM symbol is negated in the time domain. For Options 2, 3, and 4, the CP is 1/4 of the OFDM symbol. Therefore, for Options 2 and 3, there are 18 repetitions of the 1/4 STF symbol followed by the last 1/2 of the fourth OFDM symbol, which is negated in the time domain. For Option 4, there are nine repetitions of the 1/2 STF symbol followed by the last 1/2 of the fourth OFDM symbol, which is negated in the time domain.

For Option 1, the CP is also 1/4 symbol, and the STF repetition is eight times per STF symbol. Therefore, there are 36 repetitions of 1/8 STF symbol in the four STF symbols followed by the last 1/2 of the fourth OFDM symbol, which is negated in the time domain.

Figure 129 shows the STF structure for all four options. Each “s” in the figure represents one time-domain repetition of a subsequence of different length for MR-OFDM Option 1, Option 2 & 3, and Option 4.

18.2.1.1.4 STF normalization

The STF uses a lesser number of tones than the DATA field. Hence, normalization of the frequency domain STF is required to ensure that the STF power is the same as the rest of the packet. In order to have the same power as the DATA field, the normalization value is as follows:

$$\text{sqrt}(N_{\text{active}}/N_{\text{stf}})$$

where

- N_{active} is the number of used subcarriers in rest of the OFDM packet for the particular DFT option
- N_{stf} is the number of subcarriers used in the STF.

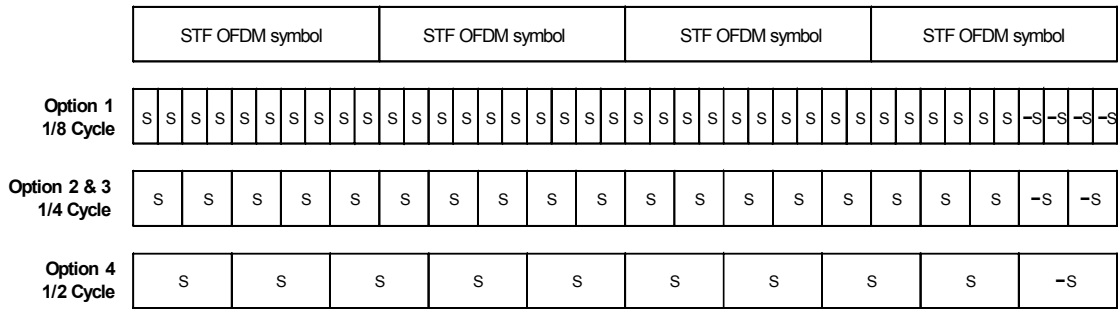

Figure 129—Structure of STF for MR-OFDM for Options 1, 2, 3, and 4

Power boosting shall be applied to the STF symbols in order to aid preamble detection. The boost should be a multiplication by 1.25, which is approximately 1.94 dB.

18.2.1.2 Long Training field (LTF)

The LTF structure in both the frequency and the time domain is described in 18.2.1.2.1 through 18.2.1.2.3.

18.2.1.2.1 Frequency domain LTF

The LTF for the four scalable bandwidth OFDM options are defined by the following four tables. Table 144 shows the frequency domain representation of the LTF for Option 1.

Table 144—Frequency domain representation of Option 1 LTF_freq(0)

Tone#	Value	Tone#	Value	Tone#	Value	Tone#	Value
-64	0	-32	-1	0	0	32	-1
-63	0	-31	-1	1	1	33	-1
-62	0	-30	-1	2	-1	34	-1
-61	0	-29	1	3	1	35	1
-60	0	-28	1	4	-1	36	1
-59	0	-27	-1	5	1	37	1
-58	0	-26	-1	6	1	38	1
-57	0	-25	-1	7	-1	39	1
-56	0	-24	-1	8	-1	40	1
-55	0	-23	-1	9	1	41	-1
-54	0	-22	1	10	-1	42	-1
-53	0	-21	1	11	1	43	-1
-52	-1	-20	-1	12	1	44	-1
-51	1	-19	1	13	1	45	-1

Table 144—Frequency domain representation of Option 1 LTF_freq(0) (continued)

Tone#	Value	Tone#	Value	Tone#	Value	Tone#	Value
-50	1	-18	-1	14	1	46	-1
-49	-1	-17	-1	15	-1	47	1
-48	-1	-16	1	16	1	48	-1
-47	-1	-15	-1	17	1	49	1
-46	-1	-14	1	18	1	50	1
-45	1	-13	1	19	1	51	-1
-44	1	-12	1	20	1	52	1
-43	-1	-11	1	21	-1	53	0
-42	-1	-10	-1	22	1	54	0
-41	1	-9	-1	23	-1	55	0
-40	1	-8	1	24	1	56	0
-39	1	-7	1	25	-1	57	0
-38	-1	-6	-1	26	1	58	0
-37	-1	-5	1	27	-1	59	0
-36	1	-4	1	28	1	60	0
-35	1	-3	-1	29	1	61	0
-34	-1	-2	1	30	-1	62	0
-33	-1	-1	1	31	1	63	0

Table 145 shows the frequency domain representation of the LTF for Option 2.

Table 145—Frequency domain representation of Option 2 LTF_freq(1)

Tone#	Value	Tone#	Value	Tone#	Value	Tone#	Value
-32	0	-16	1	0	0	16	1
-31	0	-15	-1	1	1	17	-1
-30	0	-14	1	2	-1	18	-1
-29	0	-13	1	3	1	19	-1
-28	0	-12	-1	4	1	20	-1
-27	0	-11	-1	5	-1	21	-1
-26	-1	-10	-1	6	1	22	1
-25	-1	-9	1	7	-1	23	-1
-24	-1	-8	1	8	-1	24	-1

Table 145—Frequency domain representation of Option 2 LTF_freq(1) (continued)

Tone#	Value	Tone#	Value	Tone#	Value	Tone#	Value
–23	–1	–7	–1	9	1	25	–1
–22	1	–6	1	10	–1	26	1
–21	1	–5	1	11	1	27	0
–20	1	–4	1	12	1	28	0
–19	–1	–3	–1	13	–1	29	0
–18	1	–2	–1	14	–1	30	0
–17	–1	–1	–1	15	1	31	0

Table 146 shows the frequency domain representation of the LTF for Option 3.

Table 146—Frequency domain representation of Option 3 LTF_freq(2)

Tone#	Value	Tone#	Value	Tone#	Value	Tone#	Value
–16	0	–8	1	0	0	8	–1
–15	0	–7	1	1	–1	9	1
–14	0	–6	1	2	–1	10	1
–13	1	–5	1	3	1	11	–1
–12	–1	–4	1	4	–1	12	–1
–11	1	–3	1	5	1	13	1
–10	–1	–2	1	6	1	14	0
–9	1	–1	–1	7	–1	15	0

Table 147 shows the frequency domain representation of the LTF for Option 4.

Table 147—Frequency domain representation of Option 4 LTF_freq(3)

Tone#	Value	Tone#	Value	Tone#	Value	Tone#	Value
–8	0	–4	1	0	0	4	1
–7	1	–3	–1	1	–1	5	–1
–6	–1	–2	1	2	1	6	–1
–5	1	–1	1	3	1	7	–1

18.2.1.2.2 Time domain LTF generation

The time domain LTF for Option-n ($n = 1, 2, 3, 4$) is obtained as follows:

$$\text{LTF_time}(\text{Option-n}) = \text{IDFT}(\text{LTF_freq}(\text{Option-n})).$$

A 1/2 symbol CP is prepended to two consecutive copies of the base symbol as shown in Figure 130. For more details, see 18.2.3.8.

The time-domain LTF structure is shown in Figure 130, and T_{DFT} is the duration of the base symbol.

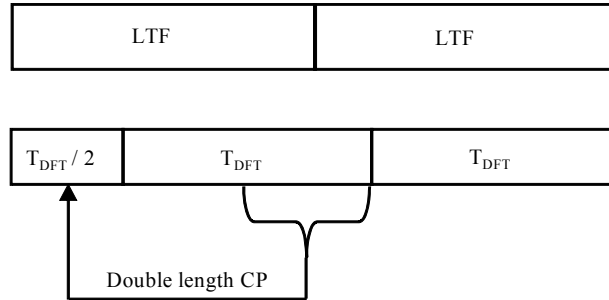

Figure 130—Structure of LTF for MR-OFDM

18.2.1.2.3 LTF normalization

Power boosting is not used by the LTF.

18.2.1.3 PHR

The PHR consists of the Frame Length field and frame control bits. The PHR structure shall be formatted as illustrated in Figure 131. All multi-bit fields are unsigned integers and shall be processed MSB first.

Bit string index	0–4	5	6–16	17–18	19–20	21	22–29	30–35
Bit mapping	RA ₄ –RA ₀	R	L ₁₀ –L ₀	R ₁ –R ₀	S ₁ –S ₀	R	H ₇ –H ₀	T ₅ –T ₀
Field name	Rate	Reserved	Frame Length	Reserved	Scrambler	Reserved	HCS	Tail

Figure 131—PHY header fields for MR-OFDM

When the PIB attribute *phyOFDMInterleaving*, as defined in 9.3, is zero (i.e., interleaving depth of one symbol), the PHR occupies three OFDM symbols for Option 1 and six OFDM symbols for Options 2, 3, and 4. When the PIB attribute *phyOFDMInterleaving* is one (i.e., interleaving depth of the number of symbols equal to the frequency domain spreading factor), the PHR occupies four OFDM symbols for Option 1, eight OFDM symbols for Option 2, and six OFDM symbols for Options 3 and 4. The PHR shall be transmitted using the lowest supported modulation and coding scheme (MCS) level, as described in Table 148, for the

option being used. It is sent to the convolutional encoder starting from the leftmost bit in Figure 131 to the rightmost bit.

The Rate field (RA_4 – RA_0) specifies the data rate of the payload and is equal to the numerical value of the MCS, as described in 18.2.3, expressed in binary format. The list of data rates for each OFDM bandwidth option can be found in 18.2.2.

The Frame Length field (L_{10} – L_0) specifies the total number of octets contained in the PSDU (prior to FEC encoding).

The Scrambler field (S_1 – S_0) specifies the scrambling seed, as described in 18.2.3.11.

The Header Check Sequence (HCS) field (H_7 – H_0) is an 8-bit CRC taken over the PHY header (PHR) fields.

The HCS shall be computed using the first 22 bits of the PHR. The HCS shall be calculated using the polynomial $G_8(x) = x^8 + x^2 + x + 1$.

The HCS is the one's complement of the modulo 2 sum of the two remainders in a) and b):

- a) The remainder resulting from $[x^k(x^7+x^6+\dots+1)]$ divided (modulo 2) by $G_8(x)$, where the value k is the number of bits in the calculation field.
- b) The remainder resulting from the calculation field contents, treated as a polynomial, multiplied by x^8 and then divided (modulo 2) by $G_8(x)$.

At the transmitter, the initial remainder of the division shall be preset to all ones and then be modified via division of the calculation field by the generator polynomial $G_8(x)$. The one's complement of this remainder is the HCS field. An example of HCS generation is given in L.3.1.

The Tail bit field (T_5 – T_0), which consists of all zeros, is for Viterbi decoder flushing, as described in 18.2.3.9.

18.2.1.4 PSDU field

The PSDU field carries the data of the PHY packet.

18.2.2 Data rates for MR-OFDM

There are four OFDM options, each with a different number of active tones. All devices supporting a particular option (1, 2, 3, or 4) shall support all BPSK and QPSK modulation and coding scheme (MCS) levels for that option. All 16 quadrature amplitude modulation (QAM) MCS levels are optional.

The various data rates are shown in Table 148. The nominal bandwidth is calculated by multiplying {the number of active tones + 1 for the DC tone} by {the subcarrier spacing}.

Table 148—Data Rates for MR-OFDM PHY

Parameter	OFDM Option 1	OFDM Option 2	OFDM Option 3	OFDM Option 4
Nominal bandwidth (kHz)	1094	552	281	156
Channel spacing (kHz)	1200	800	400	200
DFT size	128	64	32	16
Active tones	104	52	26	14
# Pilot tones	8	4	2	2
# Data tones	96	48	24	12
MCS0 (kb/s) (BPSK rate 1/2 with 4x frequency repetition)	100	50	—	—
MCS1 (kb/s) (BPSK rate 1/2 with 2x frequency repetition)	200	100	50	—
MCS2 (kb/s) (QPSK rate 1/2 and 2x frequency repetition)	400	200	100	50
MCS3 (kb/s) (QPSK rate 1/2)	800	400	200	100
MCS4 (kb/s) (QPSK rate 3/4)	—	600	300	150
MCS5 (kb/s) (16-QAM rate 1/2)	—	800	400	200
MCS6 (kb/s) (16-QAM rate 3/4)	—	—	600	300

18.2.3 Modulation and coding for MR-OFDM

18.2.3.1 Reference modulator diagram

The reference modulator diagram is shown in Figure 132.

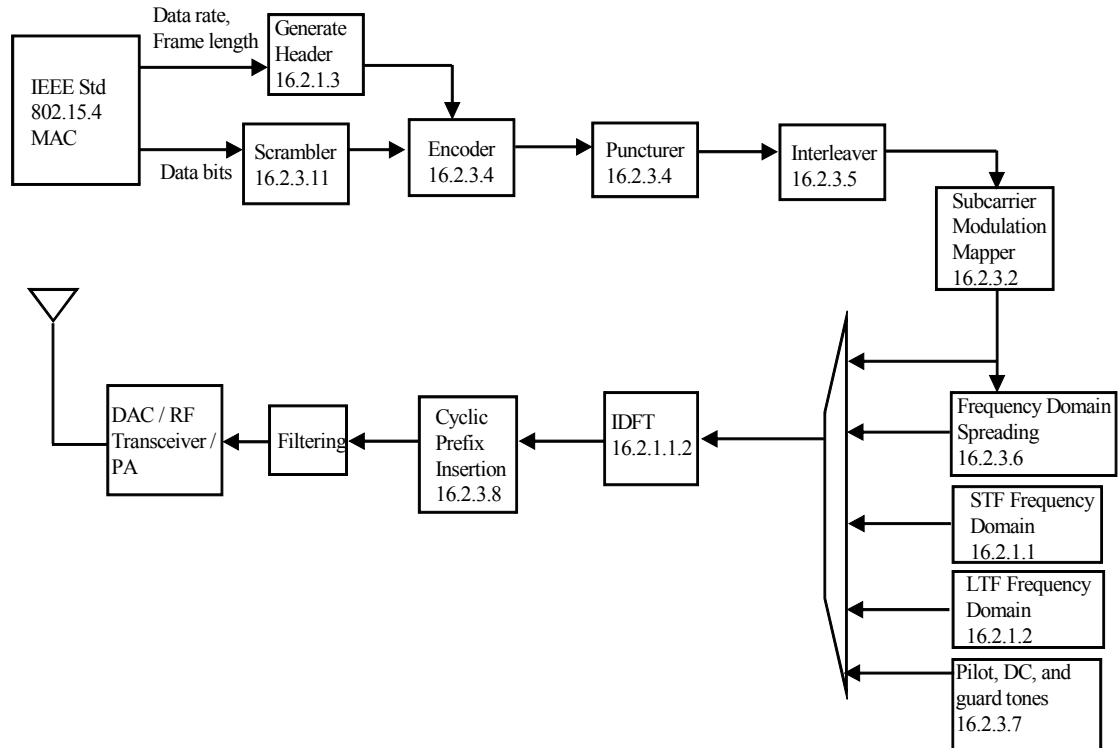

Figure 132—Reference modulator diagram for MR-OFDM

18.2.3.2 Bit-to-symbol mapping

Figure 133 shows the bit-to-symbol mapping for BPSK, QPSK, and 16-QAM.

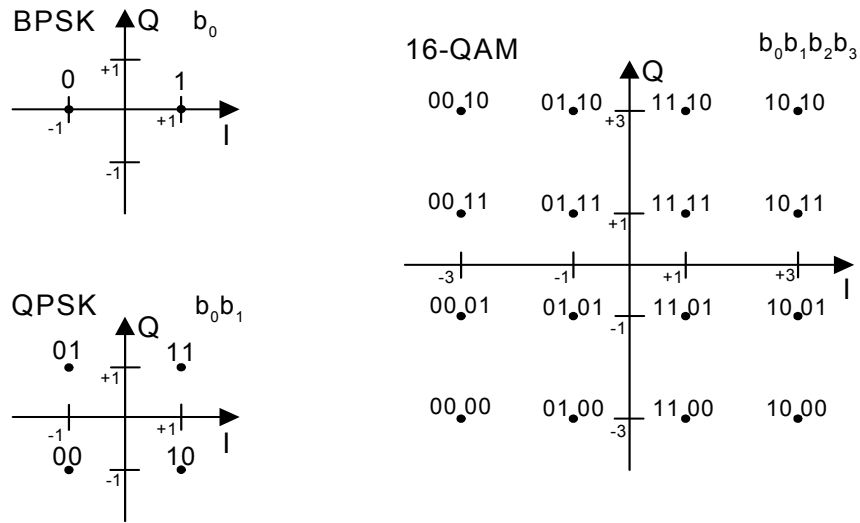

Figure 133—Bit-to-symbol mapping for MR-OFDM

The output values, d , are formed by multiplying the resulting $(I + jQ)$ value by a normalization factor K_{MOD} :

$$d = (I + jQ) \times K_{MOD}$$

The normalization factor, K_{MOD} , depends on the base modulation mode, as described in Table 149. The purpose of the normalization factor is to achieve the same average power for all mappings.

Table 149—Modulation-dependent normalization factor K_{MOD}

Modulation	K_{MOD}
BPSK	1
QPSK	$1/(\sqrt{2})$
16-QAM	$1/(\sqrt{10})$

18.2.3.3 PIB attribute values for *phySymbolsPerOctet*⁶

The number of symbols per octet depends on both the MCS level and the OFDM option, as represented in Table 150.

18.2.3.4 Forward error correction (FEC)

The DATA field shall be coded with a convolutional encoder of coding rate $R = 1/2$ or $3/4$, corresponding to the desired data rate. The convolutional encoder shall use the generator polynomials expressed in octal

⁶PHY PIB attributes are defined in 9.3.

Table 150—*phySymbolsPerOctet* values for MR-OFDM PHY

MCS level	OFDM Option			
	1	2	3	4
MCS0 (BPSK 1/2 rate coded and 4x frequency repetition)	2/3	4/3	—	—
MCS1 (BPSK 1/2 rate coded and 2x frequency repetition)	1/3	2/3	4/3	—
MCS2 (QPSK 1/2 rate coded and 2x frequency repetition)	1/6	1/3	2/3	4/3
MCS3 (QPSK 1/2 rate coded)	1/12	1/6	1/3	2/3
MCS4 (QPSK 3/4 rate coded)	—	1/9	2/9	4/9
MCS5 (16-QAM 1/2 rate coded)	—	1/12	1/6	1/3
MCS6 (16-QAM 3/4 rate coded)	—	—	1/9	2/9

representation, $g_0 = 133_8$ and $g_1 = 171_8$, of rate $R = 1/2$, as shown in Figure 134. The convolutional encoder shall be initialized to the all zeros state before encoding the PHR and then reset to the all zeros state before encoding the PSDU.

The device shall support also coding rates of $R = 3/4$, derived by puncturing, as shown in Figure 135.

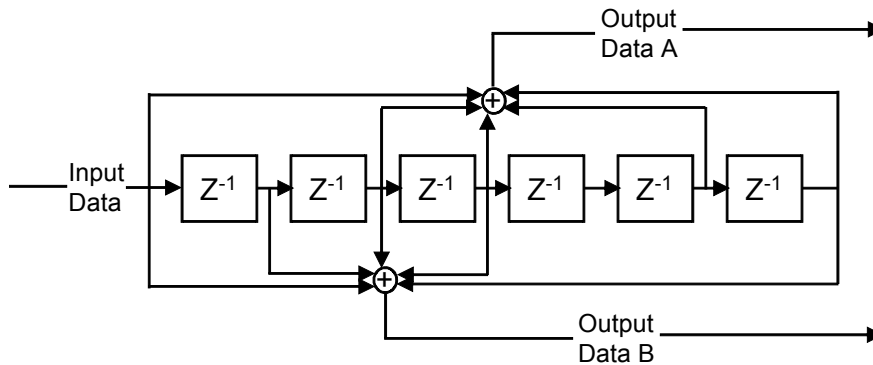

Convolutional Encoder: Rate $1/2$, constraint length $K=7$
Octal generator polynomials [133 , 171]

Figure 134—Rate 1/2 convolutional encoder

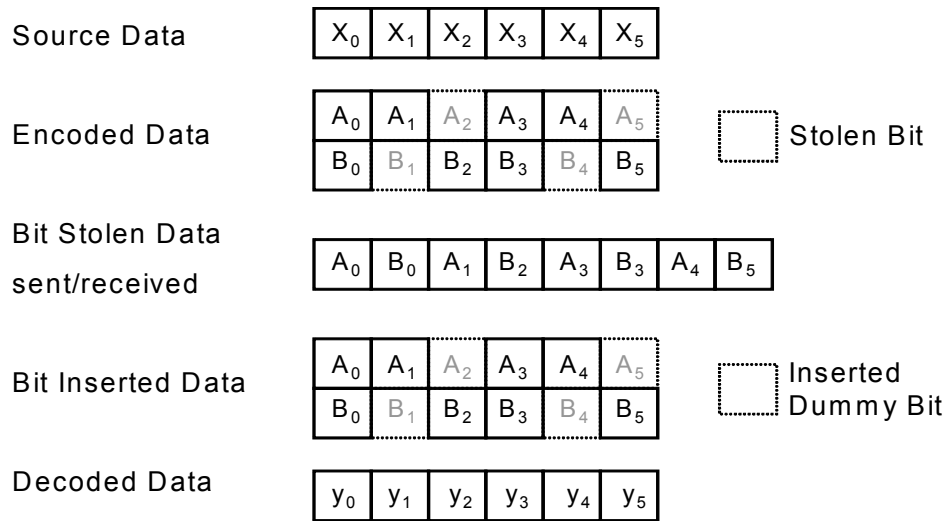

Figure 135—Puncturing for rate 3/4

18.2.3.5 Interleaver

The interleaving process consists of two permutations. The index of the coded bit before the first permutation shall be denoted as k ; i shall be the index after the first and before the second permutation; and j shall be the index after the second permutation, just prior to modulation mapping. The coded bits are written at the index given by j , and read out sequentially. The index i is defined as follows:

$$i = \left(\frac{N_{cbps}}{N_{row}} \right) \times [k \bmod(N_{row})] + \text{floor}\left(\frac{k}{N_{row}}\right)$$

where

N_{cbps} is the number of coded bits per symbol before any frequency spreading

k is 0, 1, 2, ..., ($N_{cbps} - 1$)

N_{row} is 12 when no frequency spreading is used or 12 / (spreading factor) when spreading is used

The index j is defined as follows:

$$j = s \times \text{floor}\left(\frac{i}{s}\right) + \left[i + N_{cbps} - \text{floor}\left(\frac{N_{row} \times i}{N_{cbps}}\right) \right] \bmod(s)$$

where

N_{cbps} is the number of coded bits per symbol before any frequency spreading

i is 0, 1, 2, ..., $N_{cbps} - 1$

N_{row} is 12 when no frequency spreading is used or 12 / (spreading factor) when spreading is used

and

$$s = \max\left(\frac{N_{bpsc}}{2}, 1\right)$$

where N_{bps} is the number of bits per subcarrier, and has the values 1, 2, and 4 for BPSK, QPSK, and 16-QAM, respectively.

Devices shall support an interleaving depth of one symbol, which is associated with a value of zero for the PIB attribute *phyOFDMInterleaving*, as defined in 9.3. The values for N_{cbps} with *phyOFDMInterleaving* set to zero are shown in Table 151. In this case, N_{cbps} is defined as follows: 24, 48, 96, or 192 bits for Option 1; 12, 24, 48, 96, or 192 bits for Option 2; 12, 24, 48, or 96 bits for Option 3; 12, 24, or 48 bits for Option 4.

Table 151— N_{cbps} for MR-OFDM with *phyOFDMInterleaving* = 0

MCS level	OFDM Option 1	OFDM Option 2	OFDM Option 3	OFDM Option 4
MCS0	24	12	—	—
MCS1	48	24	12	—
MCS2	96	48	24	12
MCS3	192	96	48	24
MCS4	—	96	48	24
MCS5	—	192	96	48
MCS6	—	—	96	48

Devices may support an interleaving depth of the number of symbols equal to the frequency domain spreading factor, which is associated with a value of one for the PIB attribute *phyOFDMInterleaving*. The frequency domain spreading factor can be one, two, or four. In this case, N_{cbps} is defined as follows: 96 bits for BPSK or 192 bits for QPSK in Option 1; 48 bits for BPSK, 96 bits for QPSK, or 192 bits for 16-QAM in Option 2; 24 bits for BPSK, 48 bits for QPSK, or 96 bits for 16-QAM in Option 3; 24 bits for QPSK or 48 bits for 16-QAM in Option 4.

18.2.3.6 Frequency spreading

Frequency spreading is a method of replicating PSK symbols on different carriers.

The DFT index 0 is the center of the channel, as defined in 8.1.2.9. The positive DFT indices are mapped to the higher frequencies:

$$\text{center} + N \times \text{tone spacing}$$

where N is the DFT index.

The negative DFT indices are mapped to the lower frequencies:

$$\text{center} - N \times \text{tone spacing}$$

18.2.3.6.1 Frequency spreading by 2x

The device shall offer the possibility to create a 2x repetition through frequency spreading.

The spreading is performed by first separating out the data tones from the pilot tones. The data tones are renumbered from $-N_d/2$ to -1 and 1 to $N_d/2$, where N_d is the number of data tones in an OFDM symbol. As an example with Option 3, there are two pilot tones and 24 data tones with indices from -13 to 13 excluding the DC tone. Therefore, the data tones are renumbered as $d_{-12}, d_{-11}, d_{-10}, d_{-9}, d_{-8}, d_{-7}, d_{-6}, d_{-5}, d_{-4}, d_{-3}, d_{-2}, d_{-1}$, and $d_1, d_2, d_3, d_4, d_5, d_6, d_7, d_8, d_9, d_{10}, d_{11}, d_{12}$. The DC tone is omitted since it is not used in any of the OFDM options.

The data tones to be transmitted in the OFDM symbol are placed into the positive data tones (numbered from 1 to $N_d/2$). Phase rotations are applied after copying the data tones to the negative frequencies, in order to reduce the peak-to-average power ratio of the OFDM symbol with frequency spreading. The data tones are given by

$$d_{(k-[N_d/2]-1)} = d_k e^{[j2\pi(2 \times k - 1)/4]}$$

where $k = 1, \dots, N_d/2$.

18.2.3.6.2 Frequency spreading by 4x

The device shall offer the possibility to create a 4x repetition through frequency spreading.

As with frequency spreading by 2x, the data tones are separated from the pilot tones and renumbered. The data tones to be transmitted in the OFDM symbol are placed into the lower half of the positive data tones (numbered from 1 to $N_d/4$). Phase rotations are applied after copying the data tones to the negative frequencies and upper half of the positive frequencies, in order to reduce the peak-to-average power ratio of the OFDM symbol with frequency spreading.

$$d_{(k+N_d/4)} = d_k e^{[j2\pi(k-1)/4]}$$

where $k = 1, \dots, N_d/4$.

$$d_{(k-[N_d/2]-1)} = d_k e^{[j2\pi(2 \times k - 1)/4]}$$

where $k = 1, \dots, N_d/4$.

$$d_{(k-[N_d/4]-1)} = d_k e^{[j2\pi(3 \times k - 1)/4]}$$

where $k = 1, \dots, N_d/4$.

18.2.3.6.3 No spreading

The device shall offer the possibility to map a symbol into tones without frequency spreading.

The data tones to be transmitted in the OFDM symbol are placed into the negative data tones (numbered from $-N_d/2$ to -1) followed by the positive data tones (numbered 1 to $N_d/2$).

18.2.3.7 Pilot tones / null tones

The number of pilot and null tones for each OFDM option are defined as shown in Table 152.

The pilot tones shall be transmitted with different shifts in the frequency domain, in order to enable channel estimation when the channel is changing due to Doppler. Immediately after the second LTF, the pilot shifts

Table 152—Number of pilot and null tones for MR-OFDM PHY

	OFDM Option 1	OFDM Option 2	OFDM Option 3	OFDM Option 4
Active tones	104	52	26	14
# Pilot tones	8	4	2	2
# Data tones	96	48	24 </td <td>12</td>	12
#DC null tones	1	1	1	1

change every OFDM symbol to the next set. For Options 1, 2, 3, and 4, there are 13, 7, 7, and 4 pilot sets, respectively. Figure 136 illustrates how the pilot sets cycle through the sets for Option 1. Figure 137 illustrates how the pilot sets cycle through the sets for Options 2 and 3. Figure 138 illustrates how the pilot sets cycle through the sets for Option 4. The pilot sets for each option are unique to that option. The long vertical lines show visually when each cycle through the pilots sets is complete.

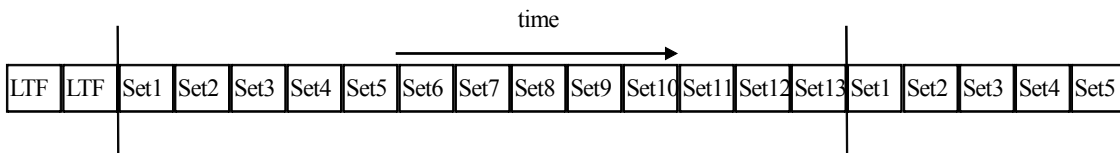

Figure 136—Pilot tone sets for Option 1

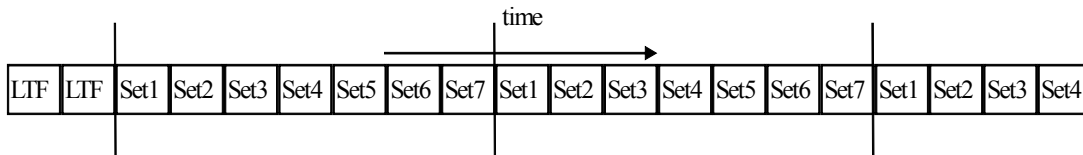

Figure 137—Pilot tone sets for Options 2 and 3

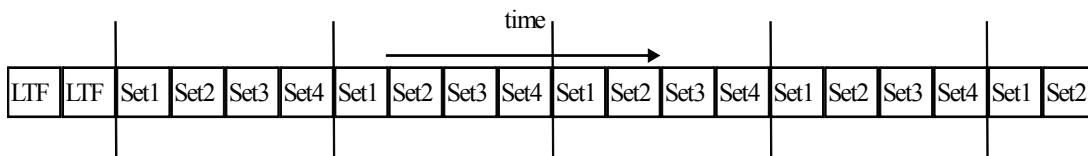

Figure 138—Pilot tone sets for Option 4

The DC tone is numbered as 0.

For Option 1, the device shall use the 13 sets of pilot tones consisting of the subcarriers shown in Table 153. The subcarriers for pilot and data are numbered as -52 to 52 with the DC tone unused.

Table 153—Pilot tones for Option 1

Pilot set 1	−38	−26	−14	−2	10	22	34	46
Pilot set 2	−46	−34	−22	−10	2	14	26	38
Pilot set 3	−42	−30	−18	−6	6	18	30	42
Pilot set 4	−50	−38	−26	−14	−2	10	22	50
Pilot set 5	−46	−34	−22	−10	2	14	34	46
Pilot set 6	−42	−30	−18	−6	6	18	26	38
Pilot set 7	−50	−38	−26	−14	−2	30	42	50
Pilot set 8	−46	−34	−22	−10	10	22	34	46
Pilot set 9	−42	−30	−18	−6	2	14	26	38
Pilot set 10	−50	−38	−26	6	18	30	42	50
Pilot set 11	−46	−34	−14	−2	10	22	34	46
Pilot set 12	−42	−30	−22	−10	2	14	26	38
Pilot set 13	−50	−18	−6	6	18	30	42	50

For Option 2, the device shall use the seven sets of pilot tones consisting of the subcarriers shown in Table 154. The subcarriers for pilot and data are numbered as −26 to 26 with the DC tone unused.

Table 154—Pilot tones for Option 2

Pilot set 1	−14	−2	10	22
Pilot set 2	−22	−10	2	14
Pilot set 3	−18	−6	6	18
Pilot set 4	−26	−14	−2	26
Pilot set 5	−22	−10	10	22
Pilot set 6	−18	−6	2	14
Pilot set 7	−26	6	18	26

For Option 3, the device shall use the seven sets of pilot tones consisting of the subcarriers shown in Table 155. The subcarriers for pilot and data are numbered as −13 to 13 with the DC tone unused.

For Option 4, the device shall use the four sets of pilot tones consisting of the subcarriers shown in Table 156. The subcarriers for pilot and data are numbered as −7 to 7 with the DC tone unused.

Table 155—Pilot tones for Option 3

Pilot set 1	−7	7
Pilot set 2	−11	3
Pilot set 3	−3	11
Pilot set 4	−9	5
Pilot set 5	−5	9
Pilot set 6	−13	1
Pilot set 7	−1	13

Table 156—Pilot tones for Option 4

Pilot set 1	−3	5
Pilot set 2	−7	1
Pilot set 3	−5	3
Pilot set 4	−1	7

The data carried on the pilot tones shall be determined by a pseudo-noise sequence PN9 with the seed “11111111”, as described in 18.1.3. The first output bit is assigned to the most negative index in Set 1. For example, for Option 3, the first output bit from the PN9 sequence is assigned to the pilot symbol with index −7 and the second output bit is assigned to the pilot symbol with index 7. Table 157 shows the mapping from PN9 bits to the pilot BPSK symbols for all OFDM options and MCS levels. Index n starts after the LTF from zero and is increased by one every pilot subcarrier.

Table 157—Mapping from PN9 sequence to pilot BPSK symbols

Input bit (PN9_n)	BPSK symbol
0	$-1 + (0 \times j)$
1	$1 + (0 \times j)$

18.2.3.8 Cyclic prefix (CP)

For the STF, the CP is defined in 18.2.1.1.3. For the LTF, the CP is defined in 18.2.1.2.2. For the remaining OFDM symbols, a CP shall be prepended to each base symbol. The duration of the CP (24 μ s) shall be 1/4 of the base symbol (96 μ s). The CP is a replication of the last 24 μ s of the base symbol. The CP is illustrated in

Figure 139. In Figure 139, N is the number of samples in the base symbol, while L is the length of the CP that is added to the base symbol.

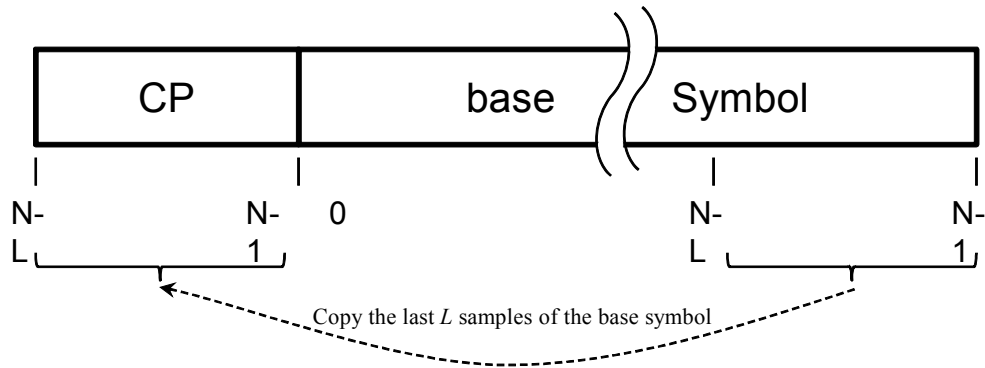

Figure 139—Cyclic prefix (CP)

18.2.3.9 PDU Tail Bit field (TAIL)

The PDU tail bit field shall be six bits of “0,” which are required to return the convolutional encoder to the “zero state.” This procedure reduces the error probability of the convolutional decoder, which relies on future bits when decoding and which may be not be available past the end of the message. The PDU tail bit field shall be produced by replacing six scrambled “zero” bits following the message end with six nonscrambled “zero” bits.

18.2.3.10 Pad bits (PAD)

The number of bits in the DATA field shall be a multiple of N_{cbps} . To achieve that, the length of the message is extended so that it becomes a multiple of N_{dbps} , the number of data bits per OFDM symbol; this case is associated with a value of zero for the PIB attribute *phyOFDMInterleaving*, as defined in 9.3. At least six bits are appended to the message, in order to accommodate the tail bits, as described in 18.2.3.9. The number of OFDM symbols, N_{SYM} ; the number of bits in the DATA field, N_{DATA} ; and the number of pad bits, N_{PAD} , are computed from the length, in octets, of the PSDU (LENGTH is equal to the content of the Frame Length field in Figure 131) as follows:

$$N_{SYM} = \text{ceiling}[(8 \times \text{LENGTH} + 6) / N_{dbps}]$$

$$N_{DATA} = N_{SYM} \times N_{dbps}$$

$$N_{PAD} = N_{DATA} - (8 \times \text{LENGTH} + 6) \tag{6}$$

The function ceiling() returns the smallest integer value greater than or equal to its argument value. The appended bits (i.e., pad bits) are set to “zeros” and are subsequently scrambled with the rest of the bits in the DATA field.

If a device supports an interleaving depth of the number of symbols equal to the frequency domain spreading factor (SF), which is associated with a value of one for the PIB attribute *phyOFDMInterleaving*, the length of the message is extended so that it becomes a multiple of N_{dbps} , the number of data bits per SF OFDM symbols, defined as $N_{dbps} = N_{cbps} \times \text{coding rate (R)}$, where N_{cbps} is the number of coded bits per SF OFDM symbols as in 18.2.3.5. The number of sets of SF OFDM symbols, N_{SYMSF} , and N_{DATA} are computed as follows:

$$N_{SYMSF} = SF \times \text{ceiling}[(8 \times \text{LENGTH} + 6) / N_{dbps}]$$

where SF may be 1, 2, or 4.

$$N_{DATA} = N_{SYMSF} \times N_{dbps} / SF$$

N_{PAD} is computed using Equation (6) as before. In the case of the PHR, 36 should be set instead of $(8 \times \text{LENGTH} + 6)$ as in 18.2.1.3.

18.2.3.11 Scrambler and scrambler seeds

The input to the scrambler is the data bits followed by tail bits and then pad bits. The scrambler uses a PN9 sequence that is shown in Figure 126. The PN9 scrambler is initialized by one of four seeds. The seed to be used for the scrambler is indicated by two bits in the PHR, as shown in Table 158. The leftmost value of the scrambling seed is placed into the leftmost delay element in Figure 126.

Table 158—Initial seeds to be used for PN9 scrambler

MSB scrambler (bit 19 of PHR) ^a	LSB scrambler (bit 20 of PHR) ^a	Scrambling seed
0	0	0 0 0 0 1 0 1 1 1
1	0	0 0 0 0 1 1 1 0 0
0	1	1 0 1 1 1 0 1 1 1
1	1	1 0 1 1 1 1 1 0 0

^aSee 18.2.1.3.

The scrambled bits are found using an XOR operation of each of the input bits with the PN9 sequence:

$$\text{bit}_n = (\text{input bit}_n) \text{ XOR } (\text{PN9}_n)$$

After scrambling, the tail bits are reset to all zeros.

18.2.4 MR-OFDM PHY RF requirements

18.2.4.1 Operating frequency range

The MR-OFDM PHY operates in the following bands:

- 470–510 MHz
- 779–787 MHz
- 863–870 MHz
- 902–928 MHz
- 917–923.5 MHz
- 920–928 MHz
- 950–958 MHz
- 2400–2483.5 MHz

18.2.4.2 Transmit power spectral density (PSD) mask

The MR-OFDM transmit PSD mask shall conform with local regulations.

18.2.4.3 Receiver sensitivity

The sensitivity requirements, as described in 8.1.7, for every Option and MCS level are shown in Table 159.

Table 159—Sensitivity requirements for OFDM options and MCS levels

	Option 1	Option 2	Option 3	Option 4
MCS0 (BPSK ½ rate coded and 4x frequency repetition)	−103 dBm	−105 dBm	—	—
MCS1 (BPSK ½ rate coded and 2x frequency repetition)	−100 dBm	−103 dBm	−105 dBm	—
MCS2 (QPSK ½ rate coded and 2x frequency repetition)	−97 dBm	−100 dBm	−103 dBm	−105 dBm
MCS3 (QPSK ½ rate coded)	−94 dBm	−97 dBm	−100 dBm	−103 dBm
MCS4 (QPSK ¾ rate coded)	—	−94 dBm	−97 dBm	−100 dBm
MCS5 (16-QAM ½ rate coded)	—	−91 dBm	−94 dBm	−97 dBm
MCS6 (16-QAM ¾ rate coded)	—	—	−91 dBm	−94 dBm

18.2.4.4 Adjacent channel rejection

The definition of an adjacent channel can be found in 11.3.5.

The adjacent channel rejection shall be measured as follows. The desired signal shall be a compliant MR-OFDM PHY signal of pseudo-random data, and the adjacent channel interferer shall be a compliant MR-OFDM PHY signal of pseudo-random data using the same MCS as the desired signal at a power level stronger than the desired signal, as indicated in Table 160 for each MCS. The desired signal is input to the receiver at a level 3 dB above the maximum allowed receiver sensitivity given in 18.2.4.3, and the PER shall be as defined in 8.1.7.

Table 160—MR-OFDM adjacent and alternate channel rejection

MCS level	Adjacent channel rejection (dB)	Alternate channel rejection (dB)
0	10	26
1	10	26
2	7	23
3	7	23
4	5	21
5	2	18
6	−2	14

18.2.4.5 Alternate channel rejection

The adjacent channels are those on either side of the desired channel that is closest in frequency to the desired channel. The alternate channel is more than one removed from the desired channel in the operational frequency band.

The alternate channel rejection shall be measured as follows. The desired signal shall be a compliant MR-OFDM PHY signal of pseudo-random data, and the alternate channel interferer shall be a compliant MR-OFDM PHY signal of pseudo-random data using the same MCS as the desired signal at a power level stronger than the desired signal, as indicated in Table 160, for each MCS. The desired signal is input to the receiver at a level 3 dB above the maximum allowed receiver sensitivity given in 18.2.4.3, and the PER shall be as defined in 8.1.7.

18.2.4.6 Tx-to-Rx turnaround time

The MR-OFDM PHY shall meet the requirements for TX-to-RX turnaround time as defined in 8.2.1.

18.2.4.7 Rx-to-Tx turnaround time

The MR-OFDM PHY shall meet the requirements for RX-to-TX turnaround time as defined in 8.2.2.

18.2.4.8 Error-vector magnitude (EVM) definition

The relative constellation RMS error averaged over subcarriers, symbols, and packets shall not exceed the values shown in Table 161.

Table 161—EVM requirements for MR-OFDM PHY

MCS	RMS error
MCS0	−10 dB
MCS1	−10 dB
MCS2	−10 dB
MCS3	−10 dB
MCS4	−13 dB
MCS5	−16 dB
MCS6	−19 dB

The transmit modulation accuracy test shall be performed by instrumentation capable of converting the transmitted signal into a stream of complex samples. The sampled signal shall be processed in a manner similar to an actual receiver, according to the following steps, or an equivalent procedure:

- a) Detect the start of packet.
- b) Detect the transition from STF to LTF, and establish fine timing (with one sample resolution).
- c) Estimate the coarse and fine frequency offsets.
- d) De-rotate the packet according to estimated frequency offset.
- e) Estimate the complex channel response coefficients for each of the subcarriers.

- f) For each data OFDM symbol, transform the symbol into subcarrier received values and divide each subcarrier value with the estimated channel response coefficient.
- g) For each N_d data-carrying subcarrier, find the closest constellation point and compute the squared Euclidean distance from it.
- h) Compute the RMS average of all errors in a packet. It is given by

$$\text{RMS}_{error} = 20\log_{10} \left(\frac{1}{N_f} \sum_{i=1}^{N_f} \sqrt{\frac{\sum_{j=1}^{N_{SYM}} \sum_{k \in U_D} \Delta(i, j, k)^2}{N_d \times N_{SYM} \times P_0}} \right)$$

with

$$\Delta(i, j, k)^2 = [I(i, j, k) - I_0(i, j, k)]^2 + [Q(i, j, k) - Q_0(i, j, k)]^2$$

where

N_{SYM}	is the number of OFDM symbols in the packet
N_f	is the number of packets used for the measurement
$U_D = \{-N_d/2, \dots, -1, 1, \dots, N_d/2\}$	is the index set of data tones
$[I_0(i, j, k), Q_0(i, j, k)]$	denotes the ideal symbol point of the i th packet, j th OFDM symbol of the packet, and k th subcarrier of the OFDM symbol in the complex plane
$[I(i, j, k), Q(i, j, k)]$	denotes the observed point of the i th packet, j th OFDM symbol of the packet, and k th tone of the OFDM symbol in the complex plane
P_0	is the average power of the constellation

The test shall be performed over at least $N_f=20$ packets. The payload of the packets under test shall contain $N_{SYM}=16$ OFDM symbols. Random data shall be used for the payload.

18.2.4.9 Transmit center frequency and symbol tolerance

The transmit center frequency tolerance shall be ± 20 ppm maximum. The symbol clock frequency tolerance shall also be ± 20 ppm maximum. The transmit center frequency and the symbol clock frequency shall be derived from the same reference oscillator.

18.2.4.10 Transmit power

A transmitter shall be capable of transmitting at least -3 dBm. Devices should transmit lower power when possible in order to reduce interference to other devices and systems.

The maximum transmit power is limited by local regulatory bodies.

18.2.4.11 Receiver maximum input level of desired signal

The MR-OFDM PHY shall have a receiver maximum input level greater than or equal to -20 dBm using the measurement defined in 8.2.4.

18.2.4.12 Receiver ED

The MR-OFDM PHY shall provide the receiver ED measurement as described in 8.2.5.

18.2.4.13 Link quality indicator

The MR-OFDM PHY shall provide the LQI measurement as described in 8.2.6.

18.2.4.14 Clear channel assessment (CCA)

The MR-OFDM PHY shall use one of the CCA methods as described in 8.2.7.

18.3 MR-O-QPSK PHY specification

The multi-rate and multi-regional offset quadrature phase-shift keying (MR-O-QPSK) PHY supports multiple PSDU data rates within each supported frequency band, as described in Table 66, employing a concatenation of outer FEC coding, interleaving, and spreading. Selection of the data rate is specified by the variable RateMode, as described in 18.3.2.4 and 18.3.2.5.

For all frequency bands, spreading is obtained by direct sequence spread spectrum (DSSS) applying various spreading factors. For the 780 MHz, 915 MHz, 917 MHz, and 2450 MHz frequency bands, the MR-O-QPSK PHY may support an alternative spreading mode for the PSDU, called multiplexed direct sequence spread spectrum (MDSSS). Selection of the spreading mode is specified by the variable SpreadingMode, which is further explained in 18.3.2.4 and 18.3.2.5.

For the 780 MHz, 915 MHz, and 2450 MHz frequency bands, the MR-O-QPSK PHY supports communication with legacy devices according to the specifications in Clause 10, as described in 18.3.3.

An MR-O-QPSK compliant device shall support at least one of the frequency bands designated in Table 66.

An example of encoding a packet for the MR-O-QPSK PHY is given in Annex N.

18.3.1 PPDU format for MR-O-QPSK

The MR-O-QPSK PPDU shall be formatted as illustrated in Figure 140.

The synchronization header (SHR), PHY header (PHR), and PHY payload components are treated as bit strings of length n , numbered b_0 on the left and b_{n-1} on the right. When transmitted, they are processed b_0 first to b_{n-1} last, without regard to their content or structure.

		Octets	
		3	Variable
Preamble	SFD	As defined in 18.3.1.3	PSDU
SHR		PHR	PHY payload

Figure 140—Format of the MR-O-QPSK PHY PPDU

18.3.1.1 Preamble field

The Preamble field shall contain a sequence of 56 bits, all zero, for the 780 MHz, 915 MHz, 917 MHz, and 2450 MHz frequency bands. It shall contain a sequence of 32 bits, all zero, for the 470 MHz, 868 MHz, 920 MHz, and 950 MHz frequency bands.

18.3.1.2 SFD

The SFD shall be the sequence described in Table 162.

Table 162—Format of the SFD field for the MR-O-QPSK PHY

SFD value (bits 0–15)
1 1 1 0 1 0 1 1 0 1 1 0 0 0 1 0

18.3.1.3 PHR

The format of the PHR is shown in Figure 141. All multi-bit fields are unsigned integers and shall be processed MSB first.

Bit string index	0	1	2	3	4	5–15	16–23
Bit mapping	SM	RM ₁	RM ₀	R ₁	R ₀	L ₁₀ –L ₀	H ₇ –H ₀
Field name	Spreading Mode	Rate Mode		Reserved		Frame Length	HCS

Figure 141—Format of the PHR for MR-O-QPSK

For the 780 MHz, 915 MHz, 917 MHz, and 2450 MHz frequency bands, the Spreading Mode (SM) field shall be set to one if MDSSS is used for PSDU spreading (variable SpreadingMode set to MDSSS, as described in 18.3.2.5). Otherwise, the SM field shall be set to zero if DSSS is used for PSDU spreading (variable SpreadingMode set to DSSS, as described in 18.3.2.4). For the 470 MHz, 868 MHz, 920 MHz, and 950 MHz frequency bands, the SM field shall be set to zero (MDSSS is not supported).

The MR-O-QPSK PHY supports up to four different PSDU rate modes within each frequency band, and the rate mode is given by the Rate Mode field (RM₁–RM₀). Table 163 shows the mapping of the bit values to the RateMode.

The Frame Length field (L₁₀–L₀) specifies the total number of octets contained in the PSDU (prior to FEC encoding).

Table 163—Rate mode mapping of the MR-O-QPSK PHY

(RM_1, RM_0)	RateMode
(0,0)	0
(0,1)	1
(1,0)	2
(1,1)	3

The Header Check Sequence (HCS) field (H_7 – H_0) is calculated over the first 16 PHR bits (b_0, b_1, \dots, b_{15}), where b_0 is the PHR bit at bit string index 0 and b_{15} is the PHR bit at bit string index 15, as described in Figure 141. The HCS field is defined as

$$(H_7, H_6, \dots, H_1, H_0) = (r_0, r_1, \dots, r_6, r_7) \tag{7}$$

for certain coefficients $r_0, r_1, \dots, r_6, r_7$. The computation of those coefficients is shown by the following algorithm.

The HCS shall be calculated using the following standard generator polynomial of degree 8:

$$G_8(x) = x^8 + x^2 + x + 1$$

The HCS shall be calculated as follows:

- Let $M(x) = b_0x^{15} + b_1x^{14} + \dots + b_{14}x + b_{15}$ be the polynomial representing the sequence of bits for which the checksum is to be computed.
- Multiply $M(x)$ by x^8 , giving the polynomial $x^8 \times M(x)$.
- Divide modulo 2 by the generator polynomial, $G_8(x)$, to obtain the remainder polynomial, $R(x) = r_0x^7 + r_1x^6 + \dots + r_6x + r_7$.

The HCS field is given by the coefficients of the remainder polynomial as shown in Equation (7). An example HCS is shown in Figure 142.

Bit string index	0	1	2	3	4	5–15	16–23
Bit mapping	SM	RM_1	RM_0	R_1	R_0	L_{10} – L_0	H_7 – H_0
Example value	0	0	1	0	0	00000101010	01111000

Figure 142—Example HCS for MR-O-QPSK

A typical implementation is depicted in Figure 143.

18.3.1.4 PSDU field

The PSDU field carries the payload data of the PHY packet.

CRC-8 Generator Polynomial: $G_8(x) = x^8 + x^2 + x + 1$

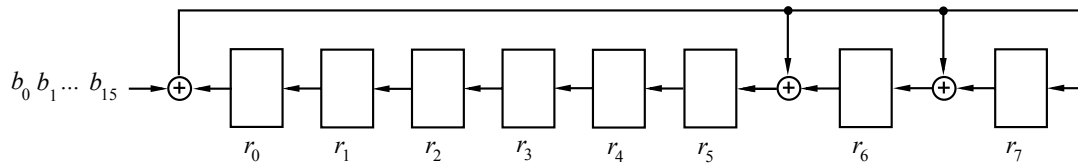

- 1) Initialize the remainder register $(r_0, r_1, \dots, r_6, r_7)$ to zero.
- 2) Shift the sequence b_0, b_1, \dots, b_{15} into the divider beginning with b_0 .
- 3) After the last bit, b_{15} , is shifted into the divider, the remainder register contains the HCS: $(r_0, r_1, \dots, r_6, r_7) = (H_7, H_6, \dots, H_0)$.

Figure 143—Typical HCS implementation for MR-O-QPSK

18.3.2 Modulation and coding for MR-O-QPSK

18.3.2.1 Reference modulator diagram

Figure 144 shows the reference modulator diagram for the MR-O-QPSK PHY.

The inputs to the reference modulator are the bit sequences of the SHR field, the PHR field, and the PSDU field. Processing of the SHR and PHR gives corresponding chip sequences c_{SHR} , as described in 18.3.2.2, and c_{PHR} , as described in 18.3.2.3, respectively. The bits of the PSDU field are processed by a dedicated signal flow depending on SpreadingMode, as described in 18.3.2.4 and 18.3.2.5. In either case, the corresponding chip sequences will be extended by pilots, as described in 18.3.2.12, resulting in a final PSDU chip sequence c_{PSDU} . The concatenated sequence of chips belonging to the PPDU

$$c_{PPDU} = \{c_{SHR}, c_{PHR}, c_{PSDU}\}$$

shall be O-QPSK modulated, as described in 18.3.2.13.

18.3.2.2 SHR coding and spreading

For the SHR bits, bit differential encoding (BDE), as described in 18.3.2.8, and subsequently $(N,1)$ -DSSS shall be applied, as described in 18.3.2.9. This shall result in an SHR chip sequence

$$c_{SHR} = \{c_0, c_1, \dots, c_{N \times (N_{\text{PREAMBLE}} + 16) - 1}\}$$

where N_{PREAMBLE} is the number of bits in the preamble, as defined in 18.3.1.1.

Table 164 shows the spreading parameters of $(N,1)$ -DSSS bit-to-chip mapping.

18.3.2.3 PHR coding and spreading

The PHR field, consisting of 24 information bits $b = \{b_0, b_1, \dots, b_{23}\}$, as described in Figure 141, shall be processed using FEC, as described in 18.3.2.6, and interleaving, as described in 18.3.2.7, resulting in 60 interleaved code-bits. For the interleaved PHR code-bits, BDE, as described in 18.3.2.8, and subsequently $(N,1)$ -DSSS shall be applied, as described in 18.3.2.9. This shall result in a PHR chip sequence:

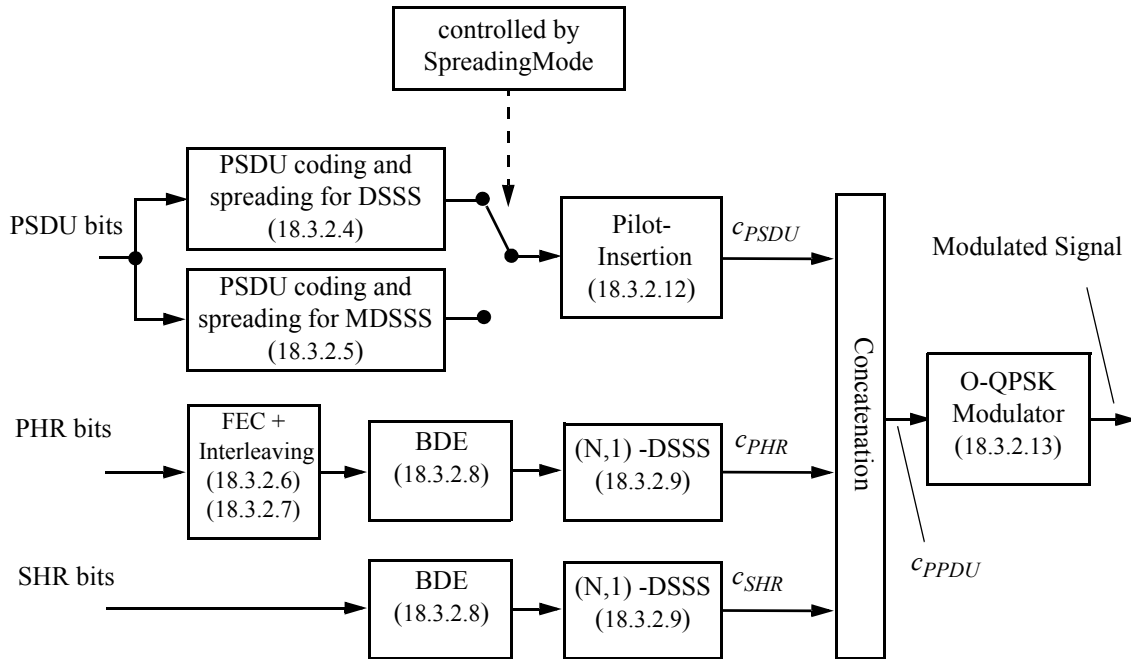

Figure 144—Reference modulator diagram

Table 164—SHR coding and spreading parameters

Frequency band (MHz)	Chip rate (kchip/s)	BDE	Spreading
470–510	100	yes	(32,1) ₀ -DSSS
779–787	1000	yes	(64,1)-DSSS
868–870	100	yes	(32,1) ₀ -DSSS
902–928	1000	yes	(64,1)-DSSS
917–923.5	1000	yes	(64,1)-DSSS
920–928	100	yes	(32,1) _{0/1} -DSSS
950–958	100	yes	(32,1) ₀ -DSSS
2400–2483.5	2000	yes	(128,1)-DSSS

$$c_{PHR} = \{c_0, c_1, \dots, c_{N \times 60 - 1}\}$$

Table 165 shows the spreading parameters of (N,1)-DSSS bit-to-chip mapping.

18.3.2.4 PSDU coding and spreading for DSSS

Figure 145 shows the signal flow when DSSS is applied to the PSDU (SpreadingMode set to DSSS).

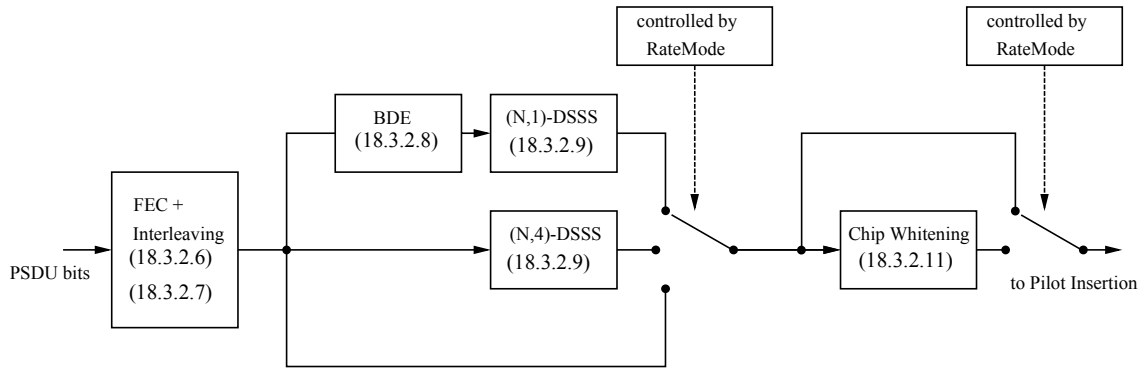

Figure 145—PSDU processing for DSSS

Table 165—PHR coding and spreading parameters

Frequency band (MHz)	Chip rate (kchip/s)	BDE	rate ½ FEC + interleaver	Spreading
470–510	100	yes	yes	(8,1) _{0/1} -DSSS
779–787	1000	yes	yes	(16,1) _{0/1} -DSSS
868–870	100	yes	yes	(8,1) _{0/1} -DSSS
902–928	1000	yes	yes	(16,1) _{0/1} -DSSS
917–923.5	1000	yes	yes	(16,1) _{0/1} -DSSS
920–928	100	yes	yes	(8,1) _{0/1} -DSSS
950–958	100	yes	yes	(8,1) _{0/1} -DSSS
2400–2483.5	2000	yes	yes	(32,1) _{0/1} -DSSS

The supported PSDU parameters for SpreadingMode DSSS are shown in Table 166. An MR-O-QPSK compliant device shall implement at least RateMode zero with SpreadingMode set to DSSS, as described in 18.3.2.4. All other possible combinations of RateMode and SpreadingMode, as described in 18.3.2.4 and 18.3.2.5, are optional.

The PSDU information bits, $b = \{b_0, b_1, \dots, b_{8 \times \text{LENGTH} - 1}\}$, with frame length of PSDU in octets (LENGTH) shall be first processed using FEC as described in 18.3.2.6, delivering a sequence of code-bits. The code-bits shall be interleaved as described in 18.3.2.7. Depending on the frequency band and RateMode, spreading by DSSS with different spreading factors shall be applied.

The first DSSS method applies BDE, as described in 18.3.2.8, to the interleaved code-bits and subsequently the (N,1)-bit-to-chip mapping as described in 18.3.2.9. The second DSSS method applies (N,4)-bit-to-chip mapping to the interleaved code-bits as described in 18.3.2.9. In this case, BDE shall not be applied, as described in Table 166. The highest PSDU data rate is obtained by bypassing BDE and spreading, as described in Figure 145 and Table 166.

Depending on the frequency band and RateMode, the output sequence of the bit-to-chip mapper shall be whitened, as described in 18.3.2.11.

Table 166—PSDU parameters for SpreadingMode DSSS

Frequency band (MHz)	Chip rate (kchip/s)	RateMode	BDE	Spreading	rate $\frac{1}{2}$ FEC + interleaver	Data rate (kb/s)
470–510	100	0	yes	(8,1) _{0/1} -DSSS	yes	6.25
		1	yes	(4,1)-DSSS	yes	12.5
		2	yes	(2,1)-DSSS	yes	25
		3	no	none	yes	50
779–787	1000	0	yes	(16,1) _{0/1} -DSSS	yes	31.25
		1	no	(16,4)-DSSS	yes	125
		2	no	(8,4)-DSSS	yes	250
		3	no	none	yes	500
868–870	100	0	yes	(8,1) _{0/1} -DSSS	yes	6.25
		1	yes	(4,1)-DSSS	yes	12.5
		2	yes	(2,1)-DSSS	yes	25
		3	no	none	yes	50
902–928	1000	0	yes	(16,1) _{0/1} -DSSS	yes	31.25
		1	no	(16,4)-DSSS	yes	125
		2	no	(8,4)-DSSS	yes	250
		3	no	none	yes	500
917–923.5	1000	0	yes	(16,1) _{0/1} -DSSS	yes	31.25
		1	no	(16,4)-DSSS	yes	125
		2	no	(8,4)-DSSS	yes	250
		3	no	none	yes	500
920–928	100	0	yes	(8,1) _{0/1} -DSSS	yes	6.25
		1	yes	(4,1)-DSSS	yes	12.5
		2	yes	(2,1)-DSSS	yes	25
		3	no	none	yes	50
950–958	100	0	yes	(8,1) _{0/1} -DSSS	yes	6.25
		1	yes	(4,1)-DSSS	yes	12.5
		2	yes	(2,1)-DSSS	yes	25
		3	no	none	yes	50
2400–2483.5	2000	0	yes	(32,1) _{0/1} -DSSS	yes	31.25
		1	no	(32,4)-DSSS	yes	125
		2	no	(16,4)-DSSS	yes	250
		3	no	(8,4)-DSSS	yes	500

The relationship between the RateMode and the DataRate parameter of the MCPS-DATA.request primitive is described in Table 46.

18.3.2.5 PSDU coding and spreading for MDSSS

Figure 146 shows the signal flow when MDSSS is applied to the PSDU (SpreadingMode set to MDSSS).

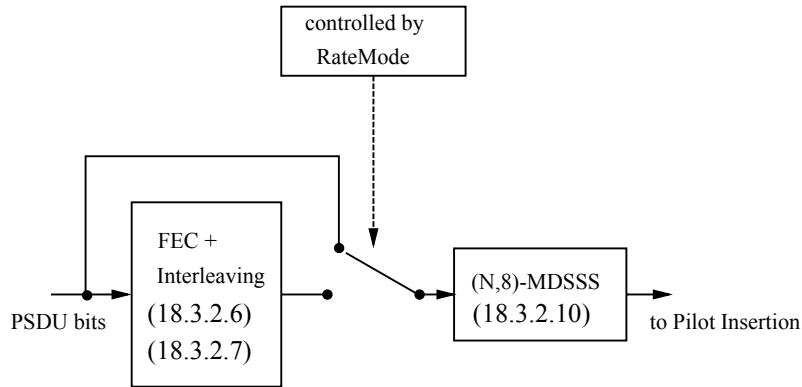

Figure 146—PSDU processing for MDSSS

The supported PSDU parameters for SpreadingMode MDSSS are shown in Table 167. The combinations of RateMode and SpreadingMode described in this subclause are optional.

The use of FEC depends on the rate mode chosen, as described in Table 167. When FEC is used, the PSDU information bits, $b = \{b_0, b_1, \dots, b_{8 \times \text{LENGTH} - 1}\}$, having a length (LENGTH) measured in octets, shall be first processed using FEC, as described in 18.3.2.6, delivering a sequence of code-bits. When FEC is enabled, the code-bits shall be interleaved, as described in 18.3.2.7; otherwise, interleaving is bypassed. The rate mode also determines which (N,8)-MDSSS spreading factor shall be used, as described in Table 167 and 18.3.2.10.

Table 167—PSDU parameters for SpreadingMode MDSSS

Frequency band (MHz)	Chip rate (kchip/s)	RateMode	BDE	Spreading	rate ½ FEC + interleaver	Data rate (kb/s)
470–510	not supported					
779–787	1000	0	no	(64,8)-MDSSS	yes	62.5
		1	no	(32,8)-MDSSS	yes	125
		2	no	(32,8)-MDSSS	no	250
		3	no	(16,8)-MDSSS	no	500
868–870	not supported					
902–928	1000	0	no	(64,8)-MDSSS	yes	62.5
		1	no	(32,8)-MDSSS	yes	125
		2	no	(32,8)-MDSSS	no	250
		3	no	(16,8)-MDSSS	no	500

Table 167—PSDU parameters for SpreadingMode MDSSS (continued)

Frequency band (MHz)	Chip rate (kchip/s)	RateMode	BDE	Spreading	rate ½ FEC + interleaver	Data rate (kb/s)
917–923.5	1000	0	no	(64,8)-MDSSS	yes	62.5
		1	no	(32,8)-MDSSS	yes	125
		2	no	(32,8)-MDSSS	no	250
		3	no	(16,8)-MDSSS	no	500
920–928	not supported					
950–958	not supported					
2400–2483.5	2000	0	no	(128,8)-MDSSS	yes	62.5
		1	no	(64,8)-MDSSS	yes	125
		2	no	(64,8)-MDSSS	no	250
		3	no	(32,8)-MDSSS	no	500

The relationship between the SpreadingMode variable and the DataRate parameter of the MCPS-DATA.request primitive is described in Table 46.

18.3.2.6 Forward error correction (FEC)

Forward error correction (FEC) shall be applied to the bits of the PHR field.

For SpreadingMode set to DSSS, FEC shall be applied to the PSDU bits, as described in Table 166. For SpreadingMode set to MDSSS, FEC is enabled depending on RateMode, as described in Table 167.

When used, FEC shall employ rate 1/2 convolutional coding with constraint length $K = 7$ using the following generator polynomials:

$$G_0(x) = 1 + x^2 + x^3 + x^5 + x^6$$

$$G_1(x) = 1 + x + x^2 + x^3 + x^6$$

The encoder is shown in Figure 147, where \oplus denotes modulo-2 addition.

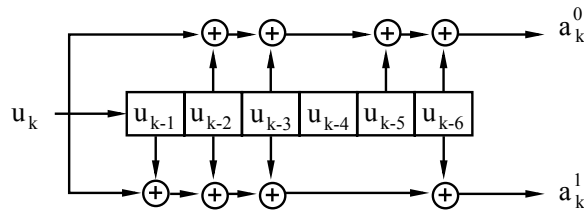

Figure 147—Convolutional encoder

Prior to convolutional encoding of the 24 PHR information bits $b = \{b_0, b_1, \dots, b_{23}\}$, as described in 18.3.1.3, the initial encoder state at $k = 0$ shall be set to

$$(u_{-1}, u_{-2}, \dots, u_{-6}) = (0, 0, 0, 0, 0, 0)$$

and the PHR information bit sequence shall be extended by a termination sequences of 6 zero bits as shown in Figure 148.

Prior to the convolutional encoding of the PSDU, the sequence of PSDU information bits $b = \{b_0, b_1, \dots, b_{8 \times \text{LENGTH} - 1}\}$, with its length (LENGTH) measured in octets, shall be extended by appending a termination sequence of six bits, all zero, and a sequence of additional bits (pad bits) as shown in Figure 148. The pad bits shall be set to zero and the number of pad bits, N_{PAD} , is computed from the number of blocks, N_B , the total number of uncoded bits, N_D , and the interleaver depth, N_{INTRLV} , as follows:

$$N_B = \text{ceiling}((8 \times \text{LENGTH} + 6) / (N_{\text{INTRLV}} / 2)) \quad (8)$$

$$N_D = N_B \times (N_{\text{INTRLV}} / 2) \quad (9)$$

$$N_{\text{PAD}} = N_D - (8 \times \text{LENGTH} + 6)$$

The function ceiling(.) is a function that returns the smallest integer value greater than or equal to its argument value.



Figure 148—PHR and PSDU extension prior to encoding

The sequence of extended information bits according to Figure 148 shall be passed to the convolutional encoder. The corresponding output sequence of code-bits, z , shall be generated as follows:

$$z = \{\dots a_k^0, a_k^1, a_{k+1}^0, a_{k+1}^1, a_{k+2}^0, a_{k+2}^1 \dots\} = \{z_0, z_1, \dots, z_{2N_D + 59}\}$$

i.e., a_k^0 is preceding sample a_k^1 . The first sample, z_0 , shall be passed to the interleaver first in time, and the last sample, $z_{2N_D + 59}$, shall be passed to the interleaver last in time.

The number of code-bits referring to a single interleaving block, N_{INTRLV} , is defined in 18.3.2.7.

18.3.2.7 Code-bit interleaving

Interleaving of PHR code-bits shall be employed and is separated from the interleaving of the PSDU code-bits. Since the PHR information bits are terminated, PHR code-bits and PSDU code-bits are independent code blocks.

Interleaving of PSDU code-bits shall be employed in conjunction with PSDU FEC, in order to improve robustness against burst errors and to break correlation of consecutive bits when applying $(N,4)$ or $(N,8)$ bit-to-chip mapping. No PSDU code-bit interleaving shall be employed if PSDU FEC is not used, as described in Table 167.

The sequence of PHR code-bits consists of a single sequence

$$z^0 = \{z_0^0, \dots, z_{N_{\text{INTRLV}}-1}^0\} = \{z_0, \dots, z_{59}\}$$

of length $N_{\text{INTRLV}} = 60$.

The sequence of PSDU code-bits consists of N_B subsequences

$$z^j = \{z_0^j, \dots, z_{N_{\text{INTRLV}}-1}^j\} = \{z_{(j-1)N_{\text{INTRLV}}+60}, \dots, z_{jN_{\text{INTRLV}}+59}\} \text{ for } j = 1, \dots, N_B$$

of length N_{INTRLV} , with N_B described in Equation (8) and N_{INTRLV} shown in Table 168.

In either case, the interleaver is defined by a permutation. The index of the code-bits before the permutation shall be denoted by k , where $k = 0$ refers to the first sample, z_0^j , and $k = N_{\text{INTRLV}} - 1$ refers to the last sample, $z_{N_{\text{INTRLV}}-1}^j$, passed to the interleaver for a given subsequence z^j . The index i shall be the index after the permutation. The permutation is defined by the rule

$$i = \frac{N_{\text{INTRLV}}}{\lambda} \times ((N_{\text{INTRLV}} - 1 - k) \bmod \lambda) + \text{floor}\left(\frac{N_{\text{INTRLV}} - 1 - k}{\lambda}\right) \quad k = 0, \dots, N_{\text{INTRLV}} - 1$$

where the degree λ is given in Table 168. The function floor(.) is a function that returns the largest integer value less than or equal to its argument value.

Table 168—Parameters of the interleaver

	Degree λ	Depth N_{INTRLV}
PHR	6	$10 \times 6 = 60$
PSDU	7	$7 \times 18 = 126$

The process of interleaving a subsequence is shown in Figure 149. The first subsequence, z^0 , shall be processed first in time and the last subsequence, z^{N_B} , shall be processed last in time.

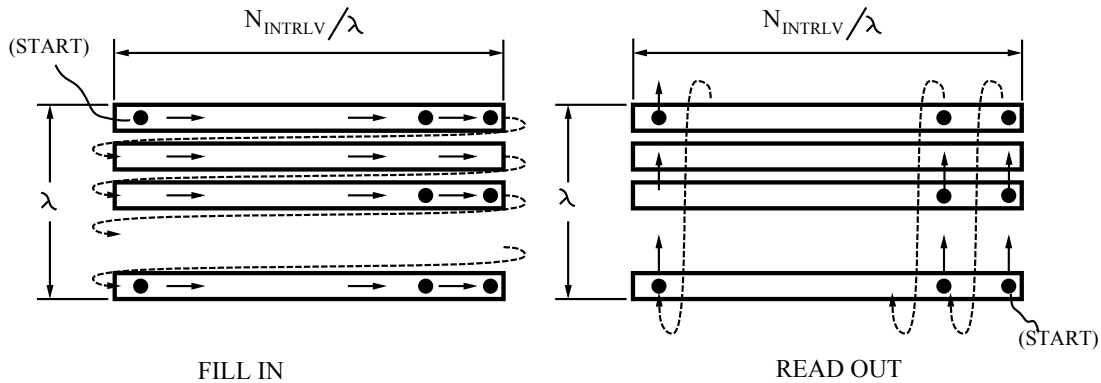

Figure 149—Interleaver

The deinterleaver, which performs the inverse relation, is defined by the rule

$$k = \lambda \times (N_{\text{INTRLV}} - 1 - i) - (N_{\text{INTRLV}} - 1) \times \text{floor}\left(\frac{\lambda \times (N_{\text{INTRLV}} - 1 - i)}{N_{\text{INTRLV}}}\right) \quad i = 0, \dots, N_{\text{INTRLV}} - 1$$

18.3.2.8 Bit differential encoding (BDE)

In conjunction with $(N,1)$ -DSSS, BDE supports noncoherent detection, which is beneficial for robust operation at low-chip SNR.

BDE is the modulo-2 addition of a raw bit with the previous encoded bit. This is performed by the transmitter and can be described by

$$E_n = R_n \oplus E_{n-1}$$

where

- R_n is the raw bit being encoded
- E_n is the corresponding differentially encoded bit
- E_{n-1} is the previous differentially encoded bit

BDE shall be applied to the bits of the SHR field resulting in a sequence $\{E_0^{\text{SHR}}, E_1^{\text{SHR}}, \dots, E_{N_{\text{SHR}}-1}^{\text{SHR}}\}$ of differentially encoded bits, where N_{SHR} is the total number of bits in the SHR, as defined in 18.3.1.1 and 18.3.1.2. The initial state, E_{-1}^{SHR} , shall be zero.

BDE shall be applied to the 60 interleaved PHR code-bits, resulting in a sequence $\{E_0^{\text{PHR}}, E_1^{\text{PHR}}, \dots, E_{59}^{\text{PHR}}\}$ of differentially encoded bits. The initial state, E_{-1}^{PHR} , is assumed to be $E_{N_{\text{SHR}}-1}^{\text{SHR}}$, assuring that during noncoherent differential detection, the very first interleaved PHR code-bit can be referenced to the last SHR bit.

If differential encoding is enabled, depending on the frequency band and RateMode, as described in Table 166, the sequence of differentially encoded PSDU bits shall be computed as follows. Let $R = \{R_0, R_1, \dots, R_{2N_D-1}\}$ be the sequence of interleaved PSDU code-bits obtained by FEC and interleaving, with N_D according to Equation (9). The pilot spacing ratio, M , is calculated using:

$$M = \frac{M_P}{N} \quad (10)$$

where

- M_P is the pilot spacing, as described in Table 182
- N is the parameter of $(N, 1)$ -DSSS, as described in Table 166

Note that M is always an integer value. Let E_n be defined as shown:

$$E_n = \begin{cases} R_n \oplus E_{n-1}, & (n \bmod M) \neq 0 \\ R_n \oplus 0, & (n \bmod M) = 0 \end{cases}$$

generating a sequence $\{E_0^{\text{PSDU}}, E_1^{\text{PSDU}}, \dots, E_{2N_D-1}^{\text{PSDU}}\}$ of differentially encoded PSDU bits.

Referencing to zero for $(n \bmod M) = 0$ assures that, during noncoherent differential detection, the very first interleaved PSDU code-bit subsequent to a pilot sequence p , as described in 18.3.2.13, can be referenced to the pilot sequence.

If BDE is not applied to the PSDU, the frequency band and RateMode, as described in Table 166 and Table 167, determine whether the sequence of interleaved PSDU code-bits (FEC is enabled) or the raw information PSDU bits (FEC is not enabled) remain unchanged.

18.3.2.9 DSSS bit-to-chip mapping

For $(N,1)$ -DSSS, a single bit is mapped to a sequences of N binary valued chips: $\{0, 1\}^1 \rightarrow \{0, 1\}^N$. The number of chips, N , depends on the frequency band and RateMode, as described in Table 166. This mapping defines a binary (N, x) block code with $x = 1$.

Table 169 through Table 175 show $(N,1)$ -DSSS used in the MR-O-QPSK PHY. For $N = 1$, the chip value is equal to the input bit value (no spreading).

Table 169—(2,1)-DSSS bit-to-chip mapping

Input bit	Chip values ($c_0 c_1$)
0	10
1	01

Table 170—(4,1)-DSSS bit-to-chip mapping

Input bit	Chip values ($c_0 c_1 \dots c_3$)
0	1010
1	0101

Table 171—(8,1)_k-DSSS bit-to-chip mapping

k	Input bit	Chip values ($c_0 c_1 \dots c_7$)
0	0	1011 0001
	1	0100 1110
1	0	0110 0011
	1	1001 1100

Table 172—(16,1)_k-DSSS bit-to-chip mapping

k	Input bit	Chip values ($c_0 c_1 \dots c_{15}$)
0	0	0010 0011 1101 0110
	1	1101 1100 0010 1001
1	0	0100 0111 1010 1100
	1	1011 1000 0101 0011

Table 173—(32,1)_k-DSSS bit-to-chip mapping

k	Input bit	Chip values (c ₀ c ₁ ... c ₃₁)
0	0	1101 1110 1010 0010 0111 0000 0110 0101
	1	0010 0001 0101 1101 1000 1111 1001 1010
1	0	1110 1111 0101 0001 0011 1000 0011 0010
	1	0001 0000 1010 1110 1100 0111 1100 1101

Table 174—(64,1)-DSSS bit-to-chip mapping

Input bit	Chip values (c ₀ c ₁ ... c ₆₃)
0	1011 0010 0010 0101 1011 0001 1101 0000
	1101 0111 0011 1101 1111 0000 0010 1010
1	0100 1101 1101 1010 0100 1110 0010 1111
	0010 1000 1100 0010 0000 1111 1101 0101

Table 175—(128,1)-DSSS bit-to-chip mapping

Input bit	Chip values (c ₀ c ₁ ... c ₁₂₇)
0	1001 1000 1000 1011 0100 1110 0100 0010
	0101 0010 0110 1101 1100 0111 1010 0000
	1101 0100 0110 0101 1101 1000 0111 0101
	1110 0111 1101 1111 1000 0000 1010 1011
1	0110 0111 0111 0100 1011 0001 1011 1101
	1010 1101 1001 0010 0011 1000 0101 1111
	0010 1011 1001 1010 0010 0111 1000 1010
	0001 1000 0010 0000 0111 1111 0101 0100

Note that for N greater than one, $(N,1)$ -DSSS is always preceded by differential encoding, supporting noncoherent detection of the interleaved code-bits, as described in Table 164, Table 165, and Table 166.

For N equal to 8, 16, and 32, two spreading codes are defined, denoted as $(N,1)_0$ -DSSS and $(N,1)_1$ -DSSS. For the SHR, only $(N,1)_0$ -DSSS is applied, as described in Table 164. When applied to either the PHR or the PSDU, the two spreading codes shall be applied in an alternating manner, denoted as $(N,1)_{0/1}$ -DSSS, as described in Table 165 and Table 166, respectively. The time variance of the spreading code improves spectral properties while preserving a robust and simple mechanism for carrier sense⁷.

⁷When applying chip whitening according to 18.3.2.11, the spectral properties can be improved as well but carrier sense is difficult to achieve. Since the chip signal-to-noise ratio (SNR) is low for modes applying (8,1)-DSSS, (16,1)-DSSS, or (32,1)-DSSS, a mechanism for carrier sense is beneficial for clear channel assessment (CCA). For the modes where chip whitening is applied, as described in 18.3.2.11, the SNR is larger implying that CCA based on energy-detect may suffice.

In particular, let $\{E_0^{PHR}, E_1^{PHR}, \dots, E_{59}^{PHR}\}$ be the sequence of differentially encoded PHR bits and $\{E_0^{PSDU}, E_1^{PSDU}, \dots, E_{2N_{D,X}-1}^{PSDU}\}$ be the sequence of differentially encoded PSDU bits, as described in 18.3.2.8. The even indexed bits, E_{2k}^X , shall be spread with $(N,1)_0$ -DSSS and the odd indexed bits, E_{2k+1}^X , shall be spread with $(N,1)_1$ -DSSS, where $X \in \{PHR, PSDU\}$.

In order to exploit the capabilities of a trellis-based decoder for the outer FEC code, as described in 18.3.2.6, it is recommended to compute a soft decision value of the detected information bits.

When applying $(N,4)$ -DSSS, a 4-tuple of bits is mapped to a sequence of N binary valued chips: $\{0, 1\}^4 \rightarrow \{0, 1\}^N$. This mapping defines a binary (N, x) block code with $x = 4$.

Table 176, Table 177, and Table 178 show $(N,4)$ -DSSS supported by the MR-O-QPSK PHY.

Table 176—(8,4)-DSSS bit-to-chip mapping

Input bits ($b_0 b_1 b_2 b_3$)	Chip values ($c_0 c_1 \dots c_7$)
0000	0000 0001
1000	1101 0000
0100	0110 1000
1100	1011 1001
0010	1110 0101
1010	0011 0100
0110	1000 1100
1110	0101 1101
0001	1010 0010
1001	0111 0011
0101	1100 1011
1101	0001 1010
0011	0100 0110
1011	1001 0111
0111	0010 1111
1111	1111 1110

Table 177—(16,4)-DSSS bit-to-chip mapping

Input bits ($b_0 b_1 b_2 b_3$)	Chip values ($c_0 c_1 \dots c_{15}$)
0000	0011 1110 0010 0101
1000	0100 1111 1000 1001
0100	0101 0011 1110 0010
1100	1001 0100 1111 1000

Table 177—(16,4)-DSSS bit-to-chip mapping (continued)

Input bits ($b_0 b_1 b_2 b_3$)	Chip values ($c_0 c_1 \dots c_{15}$)
0010	0010 0101 0011 1110
1010	1000 1001 0100 1111
0110	1110 0010 0101 0011
1110	1111 1000 1001 0100
0001	0110 1011 0111 0000
1001	0001 1010 1101 1100
0101	0000 0110 1011 0111
1101	1100 0001 1010 1101
0011	0111 0000 0110 1011
1011	1101 1100 0001 1010
0111	1011 0111 0000 0110
1111	1010 1101 1100 0001

Table 178—(32,4)-DSSS bit-to-chip mapping

Input bits ($b_0 b_1 b_2 b_3$)	Chip values ($c_0 c_1 \dots c_{31}$)
0000	1101 1001 1100 0011 0101 0010 0010 1110
1000	1110 1101 1001 1100 0011 0101 0010 0010
0100	0010 1110 1101 1001 1100 0011 0101 0010
1100	0010 0010 1110 1101 1001 1100 0011 0101
0010	0101 0010 0010 1110 1101 1001 1100 0011
1010	0011 0101 0010 0010 1110 1101 1001 1100
0110	1100 0011 0101 0010 0010 1110 1101 1001
1110	1001 1100 0011 0101 0010 0010 1110 1101
0001	1000 1100 1001 0110 0000 0111 0111 1011
1001	1011 1000 1100 1001 0110 0000 0111 0111
0101	0111 1011 1000 1100 1001 0110 0000 0111
1101	0111 0111 1011 1000 1100 1001 0110 0000
0011	0000 0111 0111 1011 1000 1100 1001 0110
1011	0110 0000 0111 0111 1011 1000 1100 1001
0111	1001 0110 0000 0111 0111 1011 1000 1100
1111	1100 1001 0110 0000 0111 0111 1011 1000

In order to exploit the capabilities of a trellis-based decoder for the outer FEC code, as described in 18.3.2.6, it is recommended to compute a soft decision value of each individual bit of the 4-tuple of information bits.⁸

For each codeword (c_0, \dots, c_{N-1}) , the first component, c_0 , shall be transmitted first in time, and the last component, c_{N-1} , shall be transmitted last in time.

18.3.2.10 MDSSS bit-to-chip mapping

The functional block diagram in Figure 150 is provided as a reference for specifying the MDSSS. Each bit in the PSDU shall be processed through the turbo product code (TPC) encoding and multiplexing module. For the horizontal code of the TPC, 3 bits are encoded into n bits with the $[n, 3]$ Hadamard code for $n = 4, 8, 16,$ and 32. The $[4, 3]$ single parity check (SPC) encoder is employed as the vertical code of the TPC.

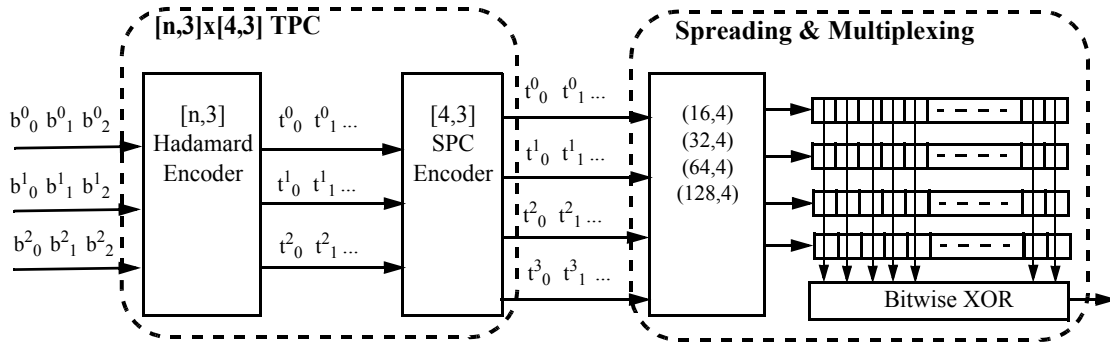

Figure 150—MDSSS signal flow

Each octet of the PSDU shall be mapped into three horizontal input rows, as specified in Table 179. The three LSBs (b_0, b_1, b_2) of each octet shall be mapped into the first horizontal input row (b^0_0, b^0_1, b^0_2), and the next three bits (b_3, b_4, b_5) of each octet shall be mapped into the second horizontal input row (b^1_0, b^1_1, b^1_2). The last horizontal input row (b^2_0, b^2_1, b^2_2) shall be mapped into the last two bits (b_6, b_7) of each octet and the reference value of the octet, which is provided by the following equation:

$$p = 0$$

Table 179—PSDU bit stream to horizontal code input mapping

Horizontal code input	b^0_0	b^0_1	b^0_2	b^1_0	b^1_1	b^1_2	b^2_0	b^2_1	b^2_2
PSDU bit stream	Bits:0	1	2	3	4	5	6	7	p

For the horizontal coding of the TPC, the three parallel bit streams (b^x_0, b^x_1, b^x_2 ; $x = 0, 1, 2$) are converted to the three parallel n -bit streams ($t^x_0, t^x_1, t^x_2, \dots, t^x_{n-1}$) through the $[n, 3]$ Hadamard encoder. An $[n, 3]$ Hadamard codeword set is given by $[h_0; h_1; h_2; h_3; h_3; h_2; h_1; h_0]$, where h_i is the i th row of the $n \times n$ Hadamard matrix and \bar{h}_i is the bitwise inversion of h_i .

⁸Since a binary $(N,4)$ block code consists of 16 codewords only, even a brute force estimate of the *a posteriori* probability (or some equivalent metric) of each information bit is feasible at low implementation cost.

For example, if $n = 4$, the $[4, 3]$ Hadamard codeword set is obtained from the (4×4) Hadamard matrix, $\bar{H}(4)$, given in the following equation, and the information bits to codeword mapping table is shown in Table 180.

$$\bar{H}(4) = \begin{bmatrix} 0 & 0 & 0 & 0 \\ 0 & 1 & 0 & 1 \\ 0 & 0 & 1 & 1 \\ 0 & 1 & 1 & 0 \end{bmatrix}$$

Table 180—Information bits to codeword mapping for $[4,3]$ Hadamard encoder

Information bits (b^x_0, b^x_1, b^x_2) ($x = 0,1,2$)	Codeword ($t^x_0, t^x_1, t^x_2, t^x_3$) ($x = 0,1,2$)
0 0 0	0 0 0 0
0 0 1	0 1 0 1
0 1 0	0 0 1 1
0 1 1	0 1 1 0
1 0 0	1 0 0 1
1 0 1	1 1 0 0
1 1 0	1 0 1 0
1 1 1	1 1 1 1

For the vertical coding of the TPC, the SPC encoder adds one n -bit parity stream ($t^3_x, x = 0,1,\dots,n-1$) to the original three parallel n -bit streams (t^0_x, t^1_x, t^2_x). For instance, if n equals four, the SPC encoder converts the three parallel 4-bit streams to four parallel 4-bit streams as shown:

$$T_{unit} = \begin{bmatrix} t^0_0 & t^0_1 & t^0_2 & t^0_3 \\ t^1_0 & t^1_1 & t^1_2 & t^1_3 \\ t^2_0 & t^2_1 & t^2_2 & t^2_3 \\ t^3_0 & t^3_1 & t^3_2 & t^3_3 \end{bmatrix}$$

where T_{unit} is the matrix of parallel bit streams and $t^3_i, i = 0, 1, 2, 3$ are obtained based on the following relationships:

$$t^3_0 = \overline{t^0_0 \oplus t^1_0 \oplus t^2_0}$$

$$t^3_1 = \overline{t^0_1 \oplus t^1_1 \oplus t^2_1}$$

$$t^3_2 = \overline{t^0_2 \oplus t^1_2 \oplus t^2_2}$$

$$t^3_3 = \overline{t^0_3 \oplus t^1_3 \oplus t^2_3}$$

As a result of [4,3] horizontal and [4,3] vertical coding with a parity bit per octet, the PSDU bit stream is transformed into a [4, 3] × [4, 3] TPC codeword matrix, forming (4 × 4) 2-dimensional data, as shown in Figure 151.

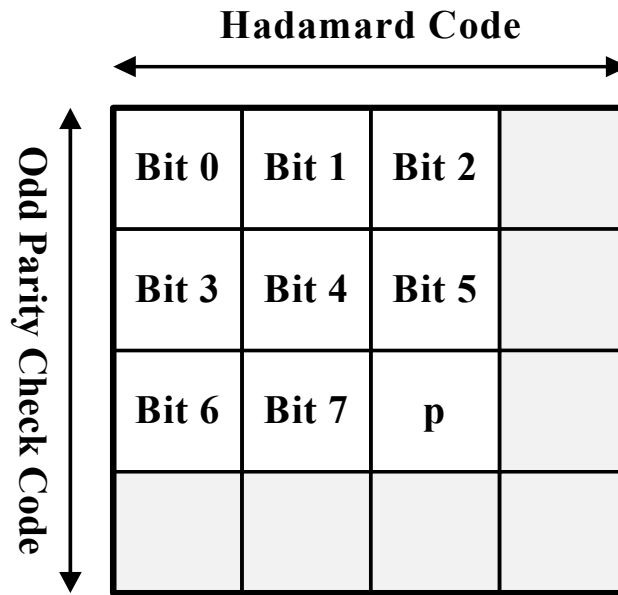

Figure 151—Structure of turbo product codeword

For $n = 8, 16,$ and $32,$ the TPC can be generated by the serial concatenations of T_{unit} .

$$T_{[n \times 4]} = \begin{cases} [T_{unit}] , n = 4 \\ [T_{unit} \ T_{unit}] , n = 8 \\ [T_{unit} \ T_{unit} \ T_{unit} \ T_{unit}] , n = 16 \\ [T_{unit} \ T_{unit} \ T_{unit} \ T_{unit} \ T_{unit} \ T_{unit} \ T_{unit} \ T_{unit}] , n = 32 \end{cases}$$

Each i th row of T_{unit} is spread with h_i ; i.e., the spread i th row of T_{unit} is given as follows:

$$s^i = [t^i_0 \oplus h_i \ t^i_1 \oplus h_i \ t^i_2 \oplus h_i \ t^i_3 \oplus h_i] , i = 0, 1, 2, 3$$

Then, the vertically multiplexed bit sequence \bar{c}_j of length 16 can be expressed as

$$\bar{c}_j = ((s^0_j \& s^1_j)|(s^2_j \& s^3_j)), (0 \leq j < 16)$$

$$\begin{aligned} \bar{c}_0 &= ((t^0_0 \& t^1_0)|(t^2_0 \& t^3_0)) \\ \bar{c}_1 &= ((t^0_0 \& \bar{t}^1_0)|(t^2_0 \& \bar{t}^3_0)) \\ \bar{c}_2 &= ((t^0_0 \& t^1_0)|(\bar{t}^2_0 \& \bar{t}^3_0)) \\ \bar{c}_3 &= ((t^0_0 \& \bar{t}^1_0)|(\bar{t}^2_0 \& t^3_0)) \\ \bar{c}_4 &= ((t^0_1 \& t^1_1)|(t^2_1 \& t^3_1)) \\ \bar{c}_5 &= ((t^0_1 \& \bar{t}^1_1)|(t^2_1 \& \bar{t}^3_1)) \\ \bar{c}_6 &= ((t^0_1 \& t^1_1)|(\bar{t}^2_1 \& \bar{t}^3_1)) \\ \bar{c}_7 &= ((t^0_1 \& \bar{t}^1_1)|(\bar{t}^2_1 \& t^3_1)) \\ \bar{c}_8 &= ((t^0_2 \& t^1_2)|(t^2_2 \& t^3_2)) \\ \bar{c}_9 &= ((t^0_2 \& \bar{t}^1_2)|(t^2_2 \& \bar{t}^3_2)) \\ \bar{c}_{10} &= ((t^0_2 \& t^1_2)|(\bar{t}^2_2 \& \bar{t}^3_2)) \\ \bar{c}_{11} &= ((t^0_2 \& \bar{t}^1_2)|(\bar{t}^2_2 \& t^3_2)) \\ \bar{c}_{12} &= ((t^0_3 \& t^1_3)|(t^2_3 \& t^3_3)) \\ \bar{c}_{13} &= ((t^0_3 \& \bar{t}^1_3)|(t^2_3 \& \bar{t}^3_3)) \\ \bar{c}_{14} &= ((t^0_3 \& t^1_3)|(\bar{t}^2_3 \& \bar{t}^3_3)) \\ \bar{c}_{15} &= ((t^0_3 \& \bar{t}^1_3)|(\bar{t}^2_3 \& t^3_3)) \end{aligned} \tag{11}$$

If n is greater than 4, the spread and multiplexed bit sequence \bar{c}_j of $T_{[nx4]}$ can also be expressed as the repeated form of Equation (11).

Then, the final output bit stream shall be bitwise XOR-ed by covering code for the chip and symbol synchronization. For each of (16,8), (32,8), (64,8), (128,8) MDSSS, the covering code shall be bit 0 of (16,1)₀-DSSS, (32,1)₀-DSSS, (64,1)-DSSS, (128,1)-DSSS code, which are described in Table 172, Table 173, Table 174, and Table 175, respectively.

The final output chip sequence, $c_0 \sim c_{4n-1}$ ($n = 4, 8, 16, 32$), of ($n,8$) MDSSS shall be described as follows:

$$c_i = \bar{c}_{\left(\left(i \bmod 4\right) + \text{floor}\left(\frac{i}{n}\right) \times 4\right)} \oplus m_i, (0 \leq i < 4n)$$

where m_i is the covering code.

18.3.2.11 Chip whitening

When SpreadingMode is set to DSSS, the PSDU chip sequence shall be whitened, depending on the frequency band and RateMode, as shown in Table 181. This improves spectral properties of modes with low spreading gain or insufficient spectral properties (i.e., notches) of the spreading codes. For all other modes, no chip whitening shall be applied.

Chip whitening is the modulo-2 addition of a chip of the PSDU at the output of the bit-to-chip mapper with the value of a cyclic m -sequence $S_{(k \bmod (2^m - 1))}$ of length $2^m - 1$ for $m = 9$. This shall be performed by the transmitter and is described by

$$c'_k = c_k \oplus S_{(k \bmod 511)}$$

Table 181—Chip Whitening for DSSS

Frequency band (MHz)	RateMode
470–510	1 and 2 and 3
779–787	2 and 3
868–870	1 and 2 and 3
902–928	2 and 3
917–923.5	2 and 3
920–928	1 and 2 and 3
950–958	1 and 2 and 3
2400–2483.5	3

where

- c_k is the raw PSDU chip being whitened
- c'_k is the whitened chip

Index k starts at 0, referring to the first chip of the PSDU at the output of the bit-to-chip mapper and is increased by one at every chip interval. Figure 152 shows the whitening process. At $k = 0$, the register shall be initialized with

$$(u_{k-1}, u_{k-2}, \dots, u_{k-9}) = (1, 0, 0, 0, 0, 0, 0, 0, 0)$$

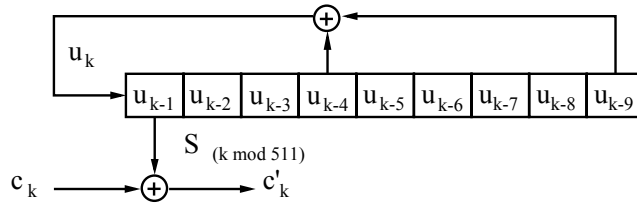

Figure 152—Chip whitening

18.3.2.12 Pilot insertion

Periodic insertion of known chip sequences (pilots) into the stream of PSDU chips shall be used to simplify symbol time, channel or phase tracking during receive, taking the finite coherence time of the radio channel into account. The pilot structure of this PHY is shown in Figure 153.

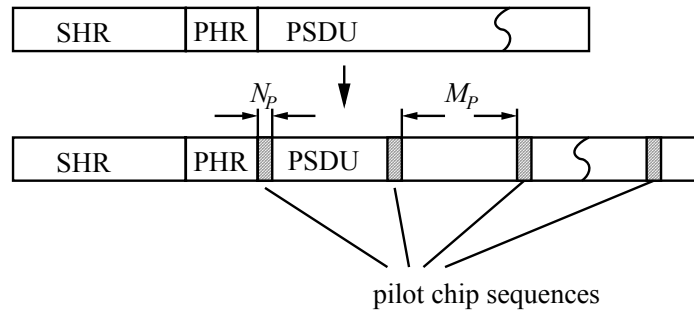

Figure 153—PSDU pilot insertion

Since the extended PSDU chip sequence always starts with a first pilot sequence, the complexity of PHR decoding can be also reduced.

The pilot length N_p (in number of chip samples), the pilot spacing M_p (in number of chip samples), and the pilot sequence $p = (p_0, p_1, \dots, p_{N_p-1})$ depend on the frequency band and are shown in Table 182.

Table 182—Pilot length, spacing and chip sequences

Frequency band (MHz)	Length N_p (# of chips)	Spacing M_p (# of chips)	Chip sequence $p = (p_0, p_1, \dots, p_{N_p-1})$
470–510	32	512	1101 1110 1010 0010 0111 0000 0110 0101
779–787	64	1024	1011 0010 0010 0101 1011 0001 1101 0000 1101 0111 0011 1101 1111 0000 0010 1010
868–870	32	512	1101 1110 1010 0010 0111 0000 0110 0101
902–928	64	1024	1011 0010 0010 0101 1011 0001 1101 0000 1101 0111 0011 1101 1111 0000 0010 1010
917–923.5	64	1024	1011 0010 0010 0101 1011 0001 1101 0000 1101 0111 0011 1101 1111 0000 0010 1010
920–928	32	512	1101 1110 1010 0010 0111 0000 0110 0101
950–958	32	512	1101 1110 1010 0010 0111 0000 0110 0101
2400–2483.5	128	2048	1001 1000 1000 1011 0100 1110 0100 0010 0101 0010 0110 1101 1100 0111 1010 0000 1101 0100 0110 0111 1101 1000 0111 0101 1110 0111 1101 1111 1000 0000 1010 1011

Let

$$u = \{u_0, u_1, \dots, u_{N_{PSDU}-1}\}$$

be the sequence of PSDU chips prior to pilot insertion, assuming the first PSDU chip sample, u_0 , is transmitted first in time, and the last PSDU chip sample, $u_{N_{PSDU}-1}$, is transmitted last in time. Depending on the frame length of PSDU in octets (LENGTH), the number N_{PSDU} can be computed by

$$N_{PSDU}(\text{LENGTH}) = \begin{cases} R_{spread} \times 2 \times N_D(\text{LENGTH}), & \text{if FEC is enabled} \\ R_{spread} \times 8 \times \text{LENGTH}, & \text{if FEC is disabled} \end{cases} \quad (12)$$

where the spreading rate, R_{spread} , is the ratio of number of output chips N to number of input bits x for (N, x) bit-to-chip mapping, as described in Table 166 and Table 167, and N_D as a function of LENGTH is defined in Equation (9).

Let L as a function of the variable LENGTH be defined as

$$L(\text{LENGTH}) = \text{ceiling}\left(\frac{N_{PSDU}(\text{LENGTH})}{M_p}\right) \quad (13)$$

Let u^j be the subsequences

$$u^j = \begin{cases} \{u_{jM_p}, u_{jM_p+1}, \dots, u_{(j+1)M_p-1}\} & \text{if } (j+1)M_p \leq N_{PSDU} \\ \{u_{jM_p}, u_{jM_p+1}, \dots, u_{N_{PSDU}-1}\} & \text{if } (j+1)M_p > N_{PSDU} \end{cases} \quad \text{for } j = 0, \dots, L-1$$

The pilot extended PSDU chip sequence is given by

$$c_{PSDU} = \{p, u^0, \dots, p, u^{L-1}\}$$

18.3.2.13 Modulation parameters for O-QPSK

A chip value shall be mapped into a binary real-valued symbol out of $\{-1, 1\}$ by the mapping

$$\zeta(c) = \begin{cases} -1, & c = 0 \\ 1, & c = 1 \end{cases} \quad (14)$$

In the 915 MHz and 2450 MHz bands, the half-sine pulse shape is used to represent each baseband chip and is given by

$$p(t) = \begin{cases} \sin\left(\frac{\pi t}{2T_c}\right), & \text{for } 0 \leq t \leq 2T_c \\ 0, & \text{otherwise} \end{cases}$$

where the chip duration T_c is the inverse of the chip rate, as described in Table 166 and Table 167.

In the 470 MHz, 868 MHz, 780 MHz, 917 MHz, 920 MHz, and 950 MHz bands, a raised cosine pulse shape with roll-off factor of $r = 0.8$ is used to represent each baseband symbol and is described by

$$v(t) = \begin{cases} \frac{\sin(\pi t/T_c)}{\pi t/T_c} \times \frac{\cos(r\pi t/T_c)}{1 - 4r^2 t^2/T_c^2}, & t \neq 0 \\ 1, & t = 0 \end{cases}$$

Let $c_{PPDU} = \{c_k\}_0^{N_{PPDU}-1}$ be the discrete-time sequence of consecutive chip samples of the PPDU, where the first sample, c_0 , is transmitted first in time and the last sample, $c_{N_{PPDU}-1}$, is transmitted last in time. The continuous-time, pulse-shaped complex baseband signal is given by:

$$y(t) = \sum_{k=0}^{N_{PPDU}/2-1} \zeta(c_{2k})p(t-2kT_c) + j\zeta(c_{2k+1})p(t-(2k+1)T_c)$$

with $j = \sqrt{-1}$ and ζ according to Equation (14).

18.3.2.14 PIB attribute values for *phySHRDuration*, *phyPHRDuration*, *phyPSDUDuration*, and *phyMaxFrameDuration*⁹

For the MR-O-QPSK PHY, the symbol rate is defined as the bit rate of the SHR. Table 183 summarizes the symbol rate, the symbol length, and the symbol duration for each supported frequency band.

Table 183—Symbol definition for MR-O-QPSK

Frequency band (MHz)	Symbol rate (ksymbol/s)	Symbol length N_S (# of chips)	Symbol duration T_S (μ s)
470–510	3.125	32	320
779–787	15.625	64	64
868–870	3.125	32	320
902–928	15.625	64	64
917–923.5	15.625	64	64
920–928	3.125	32	320
950–958	3.125	32	320
2400–2483.5	15.625	128	64

Since for a given frequency band the number of SHR bits is constant and there is only one spreading mode applied to the SHR, as described in 18.3.2.2, the attribute *phySHRDuration* (expressed in symbols) can be summarized according to Table 184. Similarly, the number of PHR code-bits is always 60 and there is a fixed spreading and coding scheme for a given frequency band, as described in 18.3.2.3. The attribute *phyPHRDuration* (expressed in symbols) is also given Table 184.

The PSDU duration depends on the PSDU length in octets (LENGTH), the variables RateMode and SpreadingMode, and the frequency band. For a given value LENGTH, the number of PSDU chip samples is

$$N_{PSDU}(\text{LENGTH}) = N_{PSDU}(\text{LENGTH}) + L(\text{LENGTH}) \times N_P$$

where N_{PSDU} is a function of LENGTH according to Equation (12). The value L as function of LENGTH is defined in Equation (13), and N_P is defined in Table 182.

⁹PHY PIB attributes are defined in 9.3.

Table 184—*phySHRDuration* and *phyPHRDuration* for MR-O-QPSK

Frequency band (MHz)	<i>phySHRDuration</i> (# of symbols)	<i>phyPHRDuration</i> (# of symbols)
470–510	48	15
779–787	72	15
868–870	48	15
902–928	72	15
917–923.5	72	15
920–928	48	15
950–958	48	15
2400–2483.5	72	15

Let *phyPSDUDuration* (expressed in symbols) be defined as

$$phyPSDUDuration(LENGTH) = \text{ceiling}\left(\frac{N_{PSDU}(LENGTH) + L(LENGTH) \times N_P}{N_S}\right)$$

where N_S is the symbol length according to Table 183. Since for a given frequency band, the length of the pilot symbol is always equal to the symbol length, viz. $N_S = N_P$, as described in Table 182 and Table 183, *phyPSDUDuration* can be expressed by

$$phyPSDUDuration(LENGTH) = \text{ceiling}\left(\frac{N_{PSDU}(LENGTH)}{N_S}\right) + \text{ceiling}\left(\frac{N_{PSDU}(LENGTH)}{M_P}\right) \quad (15)$$

with pilot spacing M_P according to Table 182. The attribute *phyMaxFrameDuration* is given by

$$phyMaxFrameDuration = phySHRDuration + phyPHRDuration + phyPSDUDuration(aMaxPHYPacketSize)$$

with *phyPSDUDuration* as a function of $LENGTH = aMaxPHYPacketSize$ according to Equation (15).

18.3.3 Support of legacy devices of the 780 MHz, 915 MHz, and 2450 MHz O-QPSK PHYs

When operating in the 779–787 MHz frequency band, a compliant device of the MR-O-QPSK PHY shall be able to communicate with devices of the 780 MHz band O-QPSK PHY within the specifications given in Clause 10.

When operating in the 902–928 MHz frequency band, a compliant device of the MR-O-QPSK PHY shall be able to communicate with devices of the 915 MHz band O-QPSK PHY within the specifications given in Clause 10.

When operating in the 2400–2483.5 MHz frequency band, a compliant device of the MR-O-QPSK PHY shall be able to communicate with devices of the 2450 MHz band O-QPSK PHY within the specifications given in Clause 10.

18.3.4 MR-O-QPSK PHY RF requirements

18.3.4.1 Operating frequency range

The MR-O-QPSK PHY operates in the following bands:

- 470–510 MHz
- 779–787 MHz
- 868–870 MHz
- 902–928 MHz
- 917–923.5 MHz
- 920–928 MHz
- 950–958 MHz
- 2400–2483.5 MHz

18.3.4.2 Transmit power spectral density (PSD) mask

The MR-O-QPSK transmit PSD mask shall conform with local regulations.

18.3.4.3 Receiver sensitivity

Under the conditions specified in 8.1.7, a compliant device shall be capable of achieving the sensitivity values given in Table 185 and Table 186 or better.

Table 185—Required receiver sensitivity for SpreadingMode DSSS [dBm]

Frequency band (MHz)	RateMode			
	0	1	2	3
470–510	–110	–105	–100	–95
779–787	–105	–100	–95	–90
868–870	–110	–105	–100	–95
902–928	–105	–100	–95	–90
917–923.5	–105	–100	–95	–90
920–928	–110	–105	–100	–95
950–958	–110	–105	–100	–95
2400–2483.5	–105	–100	–95	–90

18.3.4.4 Adjacent channel rejection

The interference-to-signal ratio (ISR) is the ratio of the signal power of an interferer relative to the signal power of the desired signal. The adjacent channel rejection shall be measured as follows: the desired signal shall be an MR-O-QPSK compliant signal of pseudo-random PSDU data. For a given RateMode, the desired signal is input to the receiver at a level 3 dB above the maximum allowed receiver sensitivity of Table 185 and Table 186.

Table 186—Required receiver sensitivity for SpreadingMode MDSSS [dBm]

Frequency band (MHz)	RateMode			
	0	1	2	3
470–510	not supported			
779–787	–105	–100	–95	–90
868–870	not supported			
902–928	–105	–100	–95	–90
917–923.5	–105	–100	–95	–90
920–928	not supported			
950–958	not supported			
2400–2483.5	–105	–100	–95	–90

The interfering signal shall be an MR-O-QPSK compliant signal with the following characteristics:

- Pseudo-random PSDU
- SpreadingMode set to either DSSS or MDSSS
- The same chip rate as the desired signal
- Chip-whitening enabled

The interferer is separated in frequency by $|\Delta f|$ from the carrier frequency of the desired channel with an ISR, as shown in Table 187. The test shall be performed for only one interfering signal at a time. The receiver shall meet the error rate criteria defined in 8.1.7 under these conditions.

Table 187—Minimum interference-to-signal ratio (ISR) requirements depending on $|\Delta f|$

Frequency band (MHz) 470–510	$ \Delta f $ (MHz)	0.4	0.8
	ISR (dB)	10	30
Frequency band (MHz) 779–787	$ \Delta f $ (MHz)	2.0	4.0
	ISR (dB)	10	30

**Table 187—Minimum interference-to-signal ratio (ISR) requirements depending on $|\Delta f|$
(continued)**

Frequency band (MHz) 868–870	$ \Delta f $ (MHz)	0.65	1.225
	ISR (dB)	10	30
Frequency band (MHz) 902–928	$ \Delta f $ (MHz)	2.0	4.0
	ISR (dB)	10	30
Frequency band (MHz) 920–928	$ \Delta f $ (MHz)	0.2	0.4
	ISR (dB)	10	30
Frequency band (MHz) 950–958	$ \Delta f $ (MHz)	0.4	0.8
	ISR (dB)	10	30
Frequency band (MHz) 2400–2483.5	$ \Delta f $ (MHz)	5.0	10.0
	ISR (dB)	10	30

18.3.4.5 Tx-to-Rx turnaround time

The MR-O-QPSK PHY shall meet the requirements for TX-to-RX turnaround time as defined in 8.2.1.

18.3.4.6 Rx-to-Tx turnaround time

The MR-O-QPSK PHY shall meet the requirements for RX-to-TX turnaround time as defined in 8.2.2.

18.3.4.7 Error-vector magnitude (EVM) definition

A transmitter shall have EVM values of less than 35% when measured for 1000 chips. The EVM measurement shall conform with 8.2.3.

18.3.4.8 Transmit center frequency and symbol tolerance

The transmit center frequency tolerance shall be ± 20 ppm maximum. When communicating with legacy devices, as described in 18.3.3, the receiver shall be capable of receiving signals with a center frequency offset tolerance of up to ± 40 ppm.

The symbol clock frequency tolerance shall be ± 20 ppm maximum. When communicating with legacy devices, as described in 18.3.3, the receiver shall be capable of receiving signals with a symbol clock frequency tolerance of up to ± 40 ppm.

The transmit center frequency and the symbol clock frequency shall be derived from the same reference oscillator.

18.3.4.9 Transmit power

A transmitter shall be capable of transmitting at least -3 dBm. Devices should transmit lower power when possible in order to reduce interference to other devices and systems.

The maximum transmit power is limited by local regulatory bodies.

18.3.4.10 Receiver maximum input level of desired signal

The MR-O-QPSK PHY shall have a receiver maximum input level greater than or equal to -20 dBm using the measurement defined in 8.2.4.

18.3.4.11 Receiver ED

The MR-O-QPSK PHY shall provide the receiver ED measurement as described in 8.2.5.

18.3.4.12 Link quality indicator

The MR-O-QPSK PHY shall provide the LQI measurement as described in 8.2.6.

18.3.4.13 Clear channel assessment (CCA)

The MR-O-QPSK PHY shall use one of the CCA methods as described in 8.2.7.

The detection time, $aCCATime$ (as defined in 9.2), for clear channel assessment (CCA) is shown in Table 188; see 8.2.7 for information on the 920 MHz band and the 950 MHz band. The ED threshold shall correspond to a received signal power of at most -90 dBm, when applying CCA Mode 1 or CCA Mode 3, as defined in 8.2.7.

Table 188—CCA duration for MR-O-QPSK PHY

Frequency band (MHz)	$aCCATime$ (# of symbols)
470–510	4
779–787	8
868–870	4
902–928	8
917–923.5	8
2400–2483.5	8

Annex A

(informative)

Bibliography

Insert the following new references at the end of the list in Annex A:

[B22] Examples of encoding a packet for the MR-FSK PHY— Part 1, Doc. IEEE 15-11-0726-07-004g, Nov. 2011.¹⁰

[B23] Examples of encoding a packet for the MR-FSK PHY— Part 2, Doc. IEEE 15-11-0759-03-004g, Nov. 2011.

¹⁰ IEEE publications are available from The Institute of Electrical and Electronics Engineers (<http://standards.ieee.org/>). This document is available at <https://mentor.ieee.org/802.15/documents>.

Annex D

(informative)

Protocol implementation conformance statement (PICS) proforma¹¹

Subclause D.2 is reproduced here to assist the reader in understanding the abbreviations and special symbols in this annex. No changes are made to D.2.

D.2 Abbreviations and special symbols

Notations for requirement status:

- M Mandatory
- O Optional
- O.n Optional, but support of at least one of the group of options labeled O.n is required.
- N/A Not applicable
- X Prohibited
- “item”: Conditional, status dependent upon the support marked for the “item”

For example, FD1: O.1 indicates that the status is optional but at least one of the features described in FD1 and FD2 is required to be implemented, if this implementation is to follow the standard to which this PICS proforma is part.

D.7 PICS proforma tables

D.7.1 Functional device types

Insert new row to end of Table D.1 (the rest of the table is not shown) as indicated:

Table D.1—Functional device types

Item number	Item description	Reference	Status	Support		
				N/A	Yes	No
<u>FD8</u>	<u>SUN PHY device</u>	<u>8.1</u>	<u>O.3</u>			
O.3: At least one of these features shall be is supported.						

¹¹Copyright release for PICS proformas: Users of this standard may freely reproduce the PICS proforma in this annex so that it can be used for its intended purpose and may further publish the completed PICS.

D.7.2 Major capabilities for the PHY

Insert the following new subclause (D.7.2.1a) after D.7.2.1:

D.7.2.1a PHY packet

The requirement for the PHY packet is described in Table D.2a.

Table D.2a—PHY packet

Item number	Item description	Reference	Status	Support		
				N/A	Yes	No
PLP1	PSDU size up to 2047 octets	9.2	FD6: M			

D.7.2.2 Radio frequency (RF)

Insert the following new rows at the end of Table D.3 (the rest of the table is not shown):

Table D.3—Radio frequency (RF)

Item number	Item description	Reference	Status	Support		
				N/A	Yes	No
RF12	SUN PHYs					
RF12.1	MR-FSK	18.1	FD6: M			
RF12.2	MR-OFDM	18.2	FD6: O			
RF12.3	MR-O-QPSK	18.3	FD6: O			
RF12.4	MR-FSK Generic PHY	8.1.2.10.2	RF10.1: O			
RF12.5	Transmit and receive enhanced beacons using CSM	8.1a	FD1, FD6, and MLF15: M			
RF12.6	At least one of the bands given in Table 66	8.1	FD6: M			
RF13	SUN PHY operating modes					
RF13.1	Operating mode #1 in one of the bands defined in Table 134	18.1	FD6: M			

Table D.3—Radio frequency (RF) (continued)

Item number	Item description	Reference	Status	Support		
				N/A	Yes	No
RF13.2	Operating mode #2 in bands defined in Table 134	18.1	FD6: O			
RF13.3	Operating mode #3 in bands defined in Table 134	18.1	FD6: O			
RF13.4	Operating mode #1 and #2 when operated in 920 MHz band	18.1	FD6: M			
RF13.5	Operating mode #3 and #4 in 920 MHz band	18.1	FD6: O			
RF13.6	Operating mode #1 and #2 when operated in 950 MHz band	18.1	FD6: M			
RF13.7	Operating mode #3 and #4 in 950 MHz band	18.1	FD6: O			
RF14	MR-FSK options					
RF14.1	MR-FSK FEC	18.1.2.4	RF10.1: O RF10.4: O			
RF14.2	MR-FSK inter-leaving	18.1.2.5	RF10.1: O RF10.4: O			
RF14.3	MR-FSK data whitening	18.1.3	RF10.1: O RF10.4: O			
RF14.4	MR-FSK mode switching	18.1.4	RF10.1: O RF10.4: O			
RF15	MR-OFDM operating modes					
RF15.1	Support for all BPSK and QPSK modes	18.2.2	RF10.2: M			
RF15.2	MR-OFDM frequency spreading	18.2.3.6	RF10.2: M			
RF16	MR-O-QPSK operating modes					
RF16.1	SpreadingMode DSSS	18.3.2.4	RF10.3: M			
RF16.2	RateMode zero	18.3	RF10.3: M			

D.7.3 Major capabilities for the MAC sublayer

D.7.3.1 MAC sublayer functions

Insert the following new row at the end of Table D.5 (the rest of the table is not shown):

Table D.5—MAC sublayer functions

Item number	Item description	Reference	Status	Support		
				N/A	Yes	No
MLF15	MPM for all coordinators when operating at more than 1% duty cycle	5.1.13	FD6: M			

D.7.3.2 MAC frames

Insert the following new row at the end of Table D.6 (the rest of the table is not shown):

Table D.6—MAC frames

Item number	Item description	Reference	Transmitter		Receiver	
			Status	Support N/A Yes No	Status	Support N/A Yes No
MF5	4-octet FCS	5.2.1.9	FD6: M		FD6: M	

Insert after Annex J the following new annex (Annex K):

Annex K

(informative)

Example usage of MR-FSK Generic PHY mechanism

K.1 Introduction

In addition to the standard-defined PHY modes specified in Table 134 and Table 135, as described in 18.1.2, an MR-FSK-compliant device may also support other modes derived using the MR-FSK Generic PHY descriptor. The MR-FSK Generic PHY descriptor provides the complete set of parameters necessary to define a FSK PHY mode, such as modulation type, symbol rate, modulation order, and modulation index for FSK operation, as described in Table 71a.

The PIB attribute *phyNumSUNPageEntriesSupported* contains the number of SUN operating modes supported by a device, and each supported mode is included in a table entry in the PIB attribute *phySUNPageEntriesSupported*. In addition, the PIB attribute *phyCurrentSUNPageEntry* specifies the current PHY mode of operation if *phyCurrentPage* equals seven or eight.

K.2 Example of SUN channel page usage for a device supporting MR-FSK Generic PHY modes

Table K.1 shows an example of a device supporting three MR-FSK Generic PHY modes. Each of the three MR-FSK Generic PHY descriptors is shown in Table K.1.

Table K.1—Example of MR-FSK Generic PHY descriptors for a device operating in the 915 MHz band

Name	PHY operating mode 0	PHY operating mode 1	PHY operating mode 2
GenericPHYID	0	1	2
FirstChannelFrequency	902.25 MHz	902.3 MHz	902.4 MHz
NumberOfChannels	52	85	64
ChannelSpacing	500 kHz	300 kHz	400 kHz
SymbolRate	76.8 ksymbol/s	100 ksymbol/s	142.222 ksymbol/s
ModulationScheme	FSK	FSK	FSK
FSKModulationOrder	2-level	2-level	2-level
FSKModulationIndex	1.0	0.5	1.0
FSKBT	n/a	n/a	n/a

K.3 Example of SUN channel page usage for a device supporting both standard-defined and MR-FSK Generic PHY modes

The example device supports three standard-defined PHY modes and one MR-FSK Generic PHY mode. The standard-defined PHY modes used in this example are the MR-FSK PHY mode for the 915 MHz band, the MR-FSK PHY mode for the 950 MHz band, and the MR-O-QPSK (DSSS) PHY mode for the 915 MHz band. If the current operating mode of the device is 915 MHz filtered FSK with a data rate of 200 kb/s, the device would have the following values for the PIB attributes:

- *phySUNNumGenericPHYDescriptors* = 1
- *phyNumSUNPageEntriesSupported* = 4
- *phySUNPageEntriesSupported*, as shown in Figure K.1
- *phyCurrentSUNPageEntry*, as shown in Figure K.2
- *phyMaxSUNChannelSupported* = 63
- *phySUNChannelsSupported* = the list of the channel numbers supported
- *phyCurrentChannel* = a unique value between 0 and *phyMaxSUNChannelSupported*
- *phyCurrentPage* = 7

Entry	Channel page	Frequency band	Modulation scheme	PHY mode
1	Page 9	915 MHz	Filtered FSK	Operating modes 1 and 3 supported
2	Page 9	950 MHz	Filtered FSK	Operating modes 1,2, and 3 supported
3	Page 10	915 MHz	O-QPSK	All four standard-defined modes supported
4	Page 10	reserved	reserved	One Generic PHY mode supported

Figure K.1—SUN page entries supported

Page 7	915 MHz	Filtered FSK	Operating mode 3 (200 kb/s) supported
--------	---------	--------------	---------------------------------------

Figure K.2—Current SUN page entry

Insert after new Annex K the following new annex (Annex L):

Annex L

(informative)

Example of encoding a packet for MR-OFDM PHY when PIB attribute *phyOFDMInterleaving* is zero

L.1 Introduction

The purpose of this annex is to show an example of encoding a packet for the MR-OFDM PHY, as described in 18.2. This example covers all the encoding details defined by this standard. The encoding illustration goes through the following stages:

- a) Generating the short training sequence section of the preamble.
- b) Generating the long preamble sequence section of the preamble.
- c) Generating the OFDM header and the corresponding HCS.
- d) Setting the six tail bits to zeros.
- e) Encoding the header with a convolutional encoder and puncturing.
- f) Interleaving the header.
- g) The PSDU from the MAC should already contain an FCS, which is assumed to be four bytes here. Six tail bits and PAD bits are appended to form the data field.
- h) Scrambling the data field.
- i) Resetting the six tail bits back to zeros.
- j) Encoding the data with a convolutional encoder and puncturing.
- k) Interleaving the data field.
- l) Mapping into complex symbols.
- m) Frequency spreading.
- n) Concatenating the preamble, the OFDM header, and the data field.
- o) Pilot, guard, and DC tone insertion.
- p) Transforming from frequency to time domain using the IFFT and adding a circular prefix.
- q) Concatenating the OFDM symbols into a single, time-domain signal.

In the description of time domain waveforms, a complex baseband signal at 666.666 ksample/s is used. This example uses the 400 kb/s data rate (QPSK 1/2-rate modulation), which corresponds to OFDM Option 2 and MCS level 3, and a message of 72 octets. The OFDM Header uses the 50 kb/s data rate (BPSK 1/2-rate coded with 4x frequency repetition), which corresponds to MCS level 0. This example also sets the PIB attribute value of *phyOFDMInterleaving* to zero.

L.2 The message

The message being encoded consists of the first 72 characters of the well-known poem “Ode to Joy” (“*An die Freude*”) by F. Schiller, in its original version (in German).

Freude, schöner Götterfunken,
Tochter aus Elysium,
Wir betreten feuertrunken,
Himmlische dein Heiligtum.

The message is converted to ASCII and a CRC32 is added, as defined in 5.2.1.9.

Note that the MAC header will not be included. It is assumed to be part of the message in this annex.

The resulting 76 octet PSDU is shown in Table L.1.

Table L.1—The message ^a

Octet #	Value (Hex)	Octet #	Value (Hex)	Octet #	Value (Hex)	Octet #	Value (Hex)
1	46	21	65	41	73	61	74
2	72	22	72	42	20	62	65
3	65	23	66	43	45	63	6E
4	75	24	75	44	6C	64	20
5	64	25	6E	45	79	65	66
6	65	26	6B	46	73	66	65
7	2C	27	65	47	69	67	75
8	20	28	6E	48	75	68	65
9	73	29	2C	49	6D	69	72
10	63	30	A	50	2C	70	74
11	68	31	54	51	A	71	72
12	F6	32	6F	52	57	72	75
13	6E	33	63	53	69	73	33
14	65	34	68	54	72	74	3C
15	72	35	74	55	20	75	69
16	20	36	65	56	62	76	7C
17	47	37	72	57	65	—	—
18	F6	38	20	58	74	—	—
19	74	39	61	59	72	—	—
20	74	40	75	60	65	—	—

^aTo extract the bit stream from this table, the octet is read LSB first.

L.3 Generation of the OFDM header

L.3.1 HCS and PAD bits insertion

In this example, the payload data has a size of 76 octets, and it will be encoded using QPSK modulation, 1/2-rate coding (Rate field value = 3). The scrambler index will be the first one (Scrambler ID = 0).

The corresponding OFDM header, including the HCS, is represented in Table L.2.

Table L.2—OFDM Header

Field Name	Bit #	Bit Value		Field Name	Bit #	Bit Value
Rate	1	0		Scrambler	20	0
	2	0			21	0
	3	0		RFU	22	0
	4	1			HCS	23
	5	1		24		1
RFU	6	0		25		1
	7	0		26		1
Length	8	0		27		1
	9	0		28		1
	10	0		29		0
	11	1		30		1
	12	0		Tail	31	0
	13	0			32	0
	14	1			33	0
	15	1			34	0
	16	0			35	0
	17	0			36	0
RFU	18	0			—	—
	19	0			—	—

In this configuration, no extra PAD bit is necessary. The size of the header will fill up exactly six OFDM symbols.

L.3.2 Convolutional encoding

After convolutional encoding of the OFDM header, the size is now doubled and the corresponding bits are represented in Table L.3. No puncturing is applied in this configuration.

Table L.3—OFDM Header after convolutional encoding

Bit #	Bit Value	Bit #	Bit Value	Bit #	Bit Value	Bit #	Bit Value
1	0	19	0	37	1	55	0
2	0	20	1	38	0	56	0
3	0	21	0	39	0	57	0
4	0	22	0	40	1	58	0
5	0	23	0	41	1	59	1
6	0	24	1	42	1	60	0
7	1	25	1	43	0	61	1
8	1	26	1	44	0	62	1
9	1	27	0	45	1	63	1
10	0	28	0	46	1	64	0
11	1	29	1	47	1	65	1
12	0	30	0	48	0	66	0
13	0	31	0	49	0	67	1
14	0	32	0	50	1	68	1
15	1	33	1	51	1	69	1
16	1	34	1	52	0	70	0
17	1	35	1	53	1	71	1
18	0	36	1	54	0	72	1

L.3.3 Interleaving

A two-step interleaver is applied to the data, as defined in 18.2.3.5. The resulting data is represented in Table L.4.

Table L.4—OFDM Header after interleaving

Bit #	Bit Value	Bit #	Bit Value	Bit #	Bit Value	Bit #	Bit Value
1	0	19	1	37	1	55	0
2	0	20	0	38	1	56	1
3	1	21	1	39	0	57	1
4	0	22	0	40	1	58	0
5	0	23	0	41	0	59	0
6	0	24	1	42	1	60	0
7	1	25	1	43	0	61	1

Table L.4—OFDM Header after interleaving (continued)

Bit #	Bit Value	Bit #	Bit Value	Bit #	Bit Value	Bit #	Bit Value
8	1	26	0	44	1	62	0
9	0	27	0	45	0	63	1
10	0	28	1	46	1	64	0
11	1	29	1	47	1	65	1
12	0	30	1	48	0	66	1
13	0	31	0	49	0	67	1
14	1	32	1	50	0	68	1
15	0	33	0	51	0	69	1
16	0	34	0	52	0	70	0
17	0	35	1	53	1	71	1
18	1	36	1	54	1	72	1

L.3.4 Bit mapping

The 72 bits are split into six OFDM symbols. The bit mapping for the OFDM header in this example is BPSK. Therefore, Q is always zero. The I value is mapped as defined in Table L.5.

Table L.5—Bit mapping for the OFDM Header

	Symbol 1		Symbol 2		Symbol 3		Symbol 4		Symbol 5		Symbol 6	
	I	Q	I	Q	I	Q	I	Q	I	Q	I	Q
1	-1	0	-1	0	1	0	1	0	-1	0	1	0
2	-1	0	1	0	-1	0	1	0	-1	0	-1	0
3	1	0	-1	0	-1	0	-1	0	-1	0	1	0
4	-1	0	-1	0	1	0	1	0	-1	0	-1	0
5	-1	0	-1	0	1	0	-1	0	1	0	1	0
6	-1	0	1	0	1	0	1	0	1	0	1	0
7	1	0	1	0	-1	0	-1	0	-1	0	1	0
8	1	0	-1	0	1	0	1	0	1	0	1	0
9	-1	0	1	0	-1	0	-1	0	1	0	1	0
10	-1	0	-1	0	-1	0	1	0	-1	0	-1	0
11	1	0	-1	0	1	0	1	0	-1	0	1	0
12	-1	0	1	0	1	0	-1	0	-1	0	1	0

L.3.5 Frequency spreading

In this example, a frequency spreading of four is applied to the OFDM header. The original 12 bits in each symbol (Bin # 25 through 36 in Table L.6) are duplicated within the same symbol. The resulting symbols have 48 data bits each. The duplicated bits have a phase rotation, as defined in 18.2.3.6.

Table L.6—OFDM Header in the frequency domain

	Symbol 1		Symbol 2		Symbol 3		Symbol 4		Symbol 5		Symbol 6	
	I	Q	I	Q	I	Q	I	Q	I	Q	I	Q
1	0	-1	0	-1	0	1	0	1	0	-1	0	1
2	0	1	0	-1	0	1	0	-1	0	1	0	1
3	0	1	0	-1	0	-1	0	-1	0	-1	0	1
4	0	1	0	1	0	-1	0	-1	0	1	0	1
5	0	-1	0	-1	0	1	0	-1	0	1	0	1
6	0	1	0	-1	0	-1	0	-1	0	-1	0	-1
7	0	1	0	1	0	-1	0	-1	0	-1	0	1
8	0	-1	0	1	0	-1	0	-1	0	-1	0	-1
9	0	-1	0	1	0	-1	0	-1	0	1	0	1
10	0	1	0	1	0	1	0	-1	0	1	0	1
11	0	1	0	-1	0	1	0	1	0	-1	0	1
12	0	1	0	-1	0	-1	0	1	0	1	0	-1
13	1	0	1	0	-1	0	-1	0	1	0	-1	0
14	0	-1	0	1	0	-1	0	1	0	-1	0	-1
15	1	0	-1	0	-1	0	-1	0	-1	0	1	0
16	0	1	0	1	0	-1	0	-1	0	1	0	1
17	1	0	1	0	-1	0	1	0	-1	0	-1	0
18	0	-1	0	1	0	1	0	1	0	1	0	1
19	1	0	1	0	-1	0	-1	0	-1	0	1	0
20	0	-1	0	1	0	-1	0	-1	0	-1	0	-1
21	1	0	-1	0	1	0	1	0	-1	0	-1	0
22	0	-1	0	-1	0	-1	0	1	0	-1	0	-1
23	1	0	-1	0	1	0	1	0	-1	0	1	0
24	0	1	0	-1	0	-1	0	1	0	1	0	-1
25	-1	0	-1	0	1	0	1	0	-1	0	1	0
26	-1	0	1	0	-1	0	1	0	-1	0	-1	0
27	1	0	-1	0	-1	0	-1	0	-1	0	1	0

Table L.6—OFDM Header in the frequency domain (continued)

	Symbol 1		Symbol 2		Symbol 3		Symbol 4		Symbol 5		Symbol 6	
	I	Q	I	Q	I	Q	I	Q	I	Q	I	Q
28	-1	0	-1	0	1	0	1	0	-1	0	-1	0
29	-1	0	-1	0	1	0	-1	0	1	0	1	0
30	-1	0	1	0	1	0	1	0	1	0	1	0
31	1	0	1	0	-1	0	-1	0	-1	0	1	0
32	1	0	-1	0	1	0	1	0	1	0	1	0
33	-1	0	1	0	-1	0	-1	0	1	0	1	0
34	-1	0	-1	0	-1	0	1	0	-1	0	-1	0
35	1	0	-1	0	1	0	1	0	-1	0	1	0
36	-1	0	1	0	1	0	-1	0	-1	0	1	0
37	-1	0	-1	0	1	0	1	0	-1	0	1	0
38	0	-1	0	1	0	-1	0	1	0	-1	0	-1
39	-1	0	1	0	1	0	1	0	1	0	-1	0
40	0	1	0	1	0	-1	0	-1	0	1	0	1
41	-1	0	-1	0	1	0	-1	0	1	0	1	0
42	0	-1	0	1	0	1	0	1	0	1	0	1
43	-1	0	-1	0	1	0	1	0	1	0	-1	0
44	0	-1	0	1	0	-1	0	-1	0	-1	0	-1
45	-1	0	1	0	-1	0	-1	0	1	0	1	0
46	0	-1	0	-1	0	-1	0	1	0	-1	0	-1
47	-1	0	1	0	-1	0	-1	0	1	0	-1	0
48	0	1	0	-1	0	-1	0	1	0	1	0	-1

L.4 Generation of the data symbols

L.4.1 PAD insertion and data scrambling

The original 76 octets of data, as defined in Table L.1, are concatenated with six zero tail bits and 10 pad bits (as calculated by the formulas in 18.2.3.10). The six tail bits are forced to zero after scrambling. The resulting 624 bits are represented in Table L.7 (first and last 48 bits only).

Table L.7—First and last 48 bits after pad insertion and scrambling

Bit #	Bit Value	Bit #	Bit Value	Bit #	Bit Value	Bit #	Bit Value
1	1	25	0	577	0	601	1
2	0	26	0	578	0	602	0
3	0	27	0	579	1	603	0
4	0	28	0	580	0	604	0
5	0	29	0	581	0	605	0
6	1	30	0	582	1	606	0
7	0	31	0	583	1	607	0
8	0	32	1	584	0	608	0
9	0	33	0	585	0	609	0
10	1	34	0	586	1	610	0
11	0	35	0	587	1	611	0
12	1	36	0	588	0	612	0
13	1	37	0	589	1	613	0
14	1	38	0	590	1	614	0
15	0	39	1	591	0	615	0
16	0	40	1	592	0	616	0
17	1	41	0	593	1	617	0
18	0	42	1	594	0	618	0
19	0	43	1	595	1	619	0
20	0	44	0	596	1	620	1
21	1	45	1	597	1	621	1
22	1	46	0	598	1	622	0
23	0	47	0	599	0	623	1
24	1	48	0	600	0	624	1

L.4.2 Convolutional encoding and puncturing

After convolutional encoding of the payload, the size is now doubled and the corresponding bits are represented in Table L.8. No puncturing is applied in this configuration.

L.4.3 Interleaving

A two-step interleaver is applied to the data, as defined in 18.2.3.5. The resulting data (first and last 48 bits only) is represented in Table L.9.

Table L.8—First and last 48 bits after convolutional encoding

Bit #	Bit Value	Bit #	Bit Value	Bit #	Bit Value	Bit #	Bit Value
1	1	25	0	1201	0	1225	0
2	1	26	1	1202	1	1226	0
3	0	27	0	1203	0	1227	0
4	1	28	1	1204	0	1228	0
5	1	29	1	1205	1	1229	0
6	1	30	1	1206	0	1230	0
7	1	31	1	1207	0	1231	0
8	1	32	1	1208	0	1232	0
9	0	33	1	1209	0	1233	0
10	0	34	0	1210	0	1234	0
11	0	35	0	1211	1	1235	0
12	1	36	0	1212	0	1236	0
13	1	37	1	1213	1	1237	0
14	0	38	0	1214	1	1238	0
15	1	39	0	1215	0	1239	1
16	1	40	0	1216	0	1240	1
17	1	41	1	1217	0	1241	1
18	1	42	1	1218	0	1242	0
19	1	43	0	1219	0	1243	1
20	1	44	0	1220	0	1244	0
21	1	45	0	1221	0	1245	1
22	1	46	1	1222	0	1246	1
23	1	47	1	1223	0	1247	0
24	1	48	1	1224	0	1248	1

Table L.9—First and last 48 bits after interleaving

Bit #	Bit Value	Bit #	Bit Value	Bit #	Bit Value	Bit #	Bit Value
1	1	25	1	1201	0	1225	0
2	1	26	1	1202	0	1226	0
3	0	27	1	1203	0	1227	1
4	1	28	0	1204	0	1228	0
5	1	29	1	1205	0	1229	0

Table L.9—First and last 48 bits after interleaving (continued)

Bit #	Bit Value	Bit #	Bit Value	Bit #	Bit Value	Bit #	Bit Value
6	0	30	1	1206	0	1230	0
7	1	31	1	1207	0	1231	0
8	0	32	0	1208	1	1232	1
9	1	33	1	1209	0	1233	1
10	0	34	1	1210	0	1234	1
11	1	35	1	1211	1	1235	1
12	0	36	1	1212	0	1236	1
13	0	37	1	1213	0	1237	1
14	0	38	0	1214	0	1238	0
15	0	39	1	1215	0	1239	0
16	1	40	1	1216	0	1240	0
17	0	41	1	1217	1	1241	1
18	1	42	1	1218	0	1242	1
19	0	43	1	1219	1	1243	1
20	0	44	1	1220	1	1244	0
21	0	45	0	1221	0	1245	0
22	1	46	1	1222	0	1246	0
23	1	47	1	1223	0	1247	0
24	0	48	0	1224	1	1248	1

L.4.4 Bit mapping

The bit mapping for the OFDM header in this example is QPSK (two data bits per vector). The I and Q vectors are mapped as defined in Figure 133. The resulting data is represented in Table L.10 (first two and last two symbols).

Table L.10—Bit mapping for the OFDM payload

Vector #	I	Q	Vector #	I	Q	Vector #	I	Q	Vector #	I	Q
1	0.707	0.707	49	0.707	-0.707	529	-0.707	-0.707	577	-0.707	0.707
2	-0.707	0.707	50	-0.707	0.707	530	-0.707	0.707	578	-0.707	-0.707
3	0.707	-0.707	51	-0.707	-0.707	531	-0.707	0.707	579	-0.707	0.707
4	0.707	-0.707	52	0.707	-0.707	532	-0.707	-0.707	580	-0.707	-0.707
5	0.707	-0.707	53	0.707	-0.707	533	-0.707	0.707	581	0.707	-0.707
6	0.707	-0.707	54	-0.707	0.707	534	-0.707	0.707	582	-0.707	0.707

Table L.10—Bit mapping for the OFDM payload (continued)

Vector #	I	Q	Vector #	I	Q	Vector #	I	Q	Vector #	I	Q
7	-0.707	-0.707	55	-0.707	-0.707	535	0.707	0.707	583	0.707	0.707
8	-0.707	0.707	56	0.707	-0.707	536	-0.707	0.707	584	-0.707	-0.707
9	-0.707	0.707	57	0.707	-0.707	537	-0.707	-0.707	585	-0.707	-0.707
10	-0.707	-0.707	58	0.707	0.707	538	-0.707	-0.707	586	-0.707	0.707
11	-0.707	0.707	59	0.707	-0.707	539	0.707	0.707	587	-0.707	-0.707
12	0.707	-0.707	60	-0.707	-0.707	540	-0.707	0.707	588	-0.707	0.707
13	0.707	0.707	61	-0.707	-0.707	541	0.707	0.707	589	-0.707	-0.707
14	0.707	-0.707	62	0.707	-0.707	542	-0.707	-0.707	590	0.707	-0.707
15	0.707	0.707	63	0.707	-0.707	543	-0.707	0.707	591	-0.707	-0.707
16	0.707	-0.707	64	-0.707	-0.707	544	-0.707	0.707	592	-0.707	0.707
17	0.707	0.707	65	-0.707	0.707	545	-0.707	0.707	593	0.707	0.707
18	0.707	0.707	66	-0.707	-0.707	546	-0.707	-0.707	594	-0.707	-0.707
19	0.707	-0.707	67	-0.707	0.707	547	-0.707	0.707	595	0.707	-0.707
20	0.707	0.707	68	0.707	0.707	548	0.707	0.707	596	-0.707	0.707
21	0.707	0.707	69	-0.707	0.707	549	0.707	0.707	597	-0.707	0.707
22	0.707	0.707	70	0.707	0.707	550	0.707	-0.707	598	-0.707	0.707
23	-0.707	0.707	71	0.707	0.707	551	0.707	-0.707	599	-0.707	-0.707
24	0.707	-0.707	72	0.707	0.707	552	-0.707	0.707	600	-0.707	-0.707
25	0.707	0.707	73	0.707	-0.707	553	-0.707	-0.707	601	-0.707	-0.707
26	0.707	-0.707	74	-0.707	-0.707	554	0.707	0.707	602	-0.707	-0.707
27	0.707	0.707	75	0.707	-0.707	555	0.707	0.707	603	-0.707	-0.707
28	0.707	-0.707	76	0.707	0.707	556	0.707	0.707	604	-0.707	0.707
29	0.707	0.707	77	-0.707	-0.707	557	-0.707	-0.707	605	-0.707	-0.707
30	0.707	-0.707	78	0.707	0.707	558	-0.707	0.707	606	0.707	-0.707
31	0.707	0.707	79	0.707	0.707	559	-0.707	0.707	607	-0.707	-0.707
32	-0.707	0.707	80	-0.707	0.707	560	0.707	0.707	608	-0.707	-0.707
33	-0.707	0.707	81	0.707	-0.707	561	-0.707	-0.707	609	0.707	-0.707
34	0.707	-0.707	82	-0.707	0.707	562	-0.707	-0.707	610	0.707	0.707
35	0.707	0.707	83	0.707	-0.707	563	-0.707	-0.707	611	-0.707	-0.707
36	0.707	-0.707	84	0.707	0.707	564	-0.707	-0.707	612	-0.707	0.707
37	-0.707	0.707	85	-0.707	0.707	565	0.707	0.707	613	-0.707	-0.707
38	-0.707	0.707	86	0.707	0.707	566	0.707	0.707	614	0.707	-0.707
39	-0.707	0.707	87	-0.707	0.707	567	-0.707	0.707	615	-0.707	-0.707
40	-0.707	0.707	88	-0.707	0.707	568	-0.707	-0.707	616	-0.707	0.707
41	-0.707	0.707	89	-0.707	0.707	569	0.707	0.707	617	0.707	0.707

Table L.10—Bit mapping for the OFDM payload (*continued*)

Vector #	I	Q	Vector #	I	Q	Vector #	I	Q	Vector #	I	Q
42	-0.707	0.707	90	0.707	0.707	570	-0.707	-0.707	618	0.707	0.707
43	0.707	-0.707	91	-0.707	-0.707	571	-0.707	-0.707	619	0.707	-0.707
44	0.707	0.707	92	-0.707	0.707	572	0.707	0.707	620	-0.707	-0.707
45	0.707	0.707	93	-0.707	0.707	573	0.707	-0.707	621	0.707	0.707
46	-0.707	0.707	94	0.707	0.707	574	0.707	-0.707	622	0.707	-0.707
47	0.707	-0.707	95	-0.707	0.707	575	0.707	0.707	623	-0.707	-0.707
48	0.707	-0.707	96	-0.707	-0.707	576	0.707	-0.707	624	-0.707	0.707

L.4.5 Frequency spreading

In this example, no frequency spreading is applied to the OFDM payload. The vectors from Table L.10 are mapped directly into the frequency domain. The next paragraphs illustrate the mapping in the frequency domain, taking into account the pilot tones, the DC tone, and the guard tones.

L.5 Conversion from frequency domain to time domain

L.5.1 Pilot, DC, and guard tone insertion

The following steps are applied to both the OFDM header and the OFDM payload. Before going to the next steps, Table L.6 and Table L.10 should be appended, resulting in 19 symbols of 48 bins in the frequency domain. The 48 bins are mapped in the frequency domain by inserting pilot tones, guard tones, and a DC tone, as defined in 18.2.3.7, and the first and last three symbols of the complete packet in the frequency domain are given in Table L.11.

Table L.11—Complete packet in the frequency domain (first and last three symbols)

Subcarrier	Symbol 1	Symbol 2	Symbol 3	Symbol 17	Symbol 18	Symbol 19
-32	0 + 0i	0 + 0i	0 + 0i	0 + 0i	0 + 0i	0 + 0i
-31	0 + 0i	0 + 0i	0 + 0i	0 + 0i	0 + 0i	0 + 0i
-30	0 + 0i	0 + 0i	0 + 0i	0 + 0i	0 + 0i	0 + 0i
-29	0 + 0i	0 + 0i	0 + 0i	0 + 0i	0 + 0i	0 + 0i
-28	0 + 0i	0 + 0i	0 + 0i	0 + 0i	0 + 0i	0 + 0i
-27	0 + 0i	0 + 0i	0 + 0i	0 + 0i	0 + 0i	0 + 0i
-26	0 - 1i	0 - 1i	0 + 1i	-0.707 + 0.707i	1 + 0i	-0.707 + 0.707i
-25	0 + 1i	0 - 1i	0 + 1i	-0.707 - 0.707i	-0.707 - 0.707i	-0.707 - 0.707i
-24	0 + 1i	0 - 1i	0 - 1i	0.707 + 0.707i	-0.707 + 0.707i	-0.707 + 0.707i

**Table L.11—Complete packet in the frequency domain (first and last three symbols)
(continued)**

Subcarrier	Symbol 1	Symbol 2	Symbol 3	Symbol 17	Symbol 18	Symbol 19
-23	$0 + 1i$	$0 + 1i$	$0 - 1i$	$0.707 - 0.707i$	$-0.707 + 0.707i$	$-0.707 - 0.707i$
-22	$0 - 1i$	$1 + 0i$	$0 + 1i$	$0.707 - 0.707i$	$-0.707 - 0.707i$	$1 + 0i$
-21	$0 + 1i$	$0 - 1i$	$0 - 1i$	$0.707 - 0.707i$	$-0.707 + 0.707i$	$0.707 - 0.707i$
-20	$0 + 1i$	$0 - 1i$	$0 - 1i$	$-0.707 - 0.707i$	$-0.707 + 0.707i$	$-0.707 + 0.707i$
-19	$0 - 1i$	$0 + 1i$	$0 - 1i$	$-0.707 - 0.707i$	$0.707 + 0.707i$	$0.707 + 0.707i$
-18	$0 - 1i$	$0 + 1i$	$-1 + 0i$	$1 + 0i$	$-0.707 + 0.707i$	$-0.707 - 0.707i$
-17	$0 + 1i$	$0 + 1i$	$0 - 1i$	$0.707 + 0.707i$	$-0.707 - 0.707i$	$-0.707 - 0.707i$
-16	$0 + 1i$	$0 + 1i$	$0 + 1i$	$-0.707 - 0.707i$	$-0.707 - 0.707i$	$-0.707 + 0.707i$
-15	$0 + 1i$	$0 - 1i$	$0 + 1i$	$0.707 + 0.707i$	$0.707 + 0.707i$	$-0.707 - 0.707i$
-14	$-1 + 0i$	$0 - 1i$	$0 - 1i$	$0.707 - 0.707i$	$1 + 0i$	$-0.707 + 0.707i$
-13	$1 + 0i$	$1 + 0i$	$-1 + 0i$	$-0.707 - 0.707i$	$-0.707 + 0.707i$	$-0.707 - 0.707i$
-12	$0 - 1i$	$0 + 1i$	$0 - 1i$	$-0.707 + 0.707i$	$0.707 + 0.707i$	$0.707 - 0.707i$
-11	$1 + 0i$	$-1 + 0i$	$-1 + 0i$	$-0.707 - 0.707i$	$-0.707 - 0.707i$	$-0.707 - 0.707i$
-10	$0 + 1i$	$1 + 0i$	$0 - 1i$	$0.707 + 0.707i$	$-0.707 + 0.707i$	$-1 + 0i$
-9	$1 + 0i$	$0 + 1i$	$-1 + 0i$	$-0.707 - 0.707i$	$-0.707 + 0.707i$	$-0.707 + 0.707i$
-8	$0 - 1i$	$1 + 0i$	$0 + 1i$	$0.707 + 0.707i$	$-0.707 + 0.707i$	$0.707 + 0.707i$
-7	$1 + 0i$	$0 + 1i$	$-1 + 0i$	$0.707 + 0.707i$	$-0.707 - 0.707i$	$-0.707 - 0.707i$
-6	$0 - 1i$	$1 + 0i$	$1 + 0i$	$-1 + 0i$	$-0.707 + 0.707i$	$0.707 - 0.707i$
-5	$1 + 0i$	$0 + 1i$	$0 - 1i$	$0.707 + 0.707i$	$0.707 + 0.707i$	$-0.707 + 0.707i$
-4	$0 - 1i$	$-1 + 0i$	$1 + 0i$	$-0.707 + 0.707i$	$0.707 + 0.707i$	$-0.707 + 0.707i$
-3	$1 + 0i$	$0 - 1i$	$0 - 1i$	$0.707 - 0.707i$	$0.707 - 0.707i$	$-0.707 + 0.707i$
-2	$-1 + 0i$	$-1 + 0i$	$1 + 0i$	$0.707 - 0.707i$	$-1 + 0i$	$-0.707 - 0.707i$
-1	$0 + 1i$	$0 - 1i$	$0 - 1i$	$0.707 + 0.707i$	$0.707 - 0.707i$	$-0.707 - 0.707i$
0	$0 + 0i$	$0 + 0i$	$0 + 0i$	$0 + 0i$	$0 + 0i$	$0 + 0i$
1	$-1 + 0i$	$-1 + 0i$	$1 + 0i$	$-0.707 + 0.707i$	$-0.707 + 0.707i$	$-0.707 - 0.707i$
2	$-1 + 0i$	$1 + 0i$	$-1 + 0i$	$0.707 - 0.707i$	$-0.707 - 0.707i$	$-0.707 - 0.707i$
3	$1 + 0i$	$1 + 0i$	$-1 + 0i$	$0.707 + 0.707i$	$0.707 + 0.707i$	$-0.707 - 0.707i$
4	$-1 + 0i$	$-1 + 0i$	$1 + 0i$	$-0.707 + 0.707i$	$0.707 + 0.707i$	$-0.707 + 0.707i$
5	$-1 + 0i$	$-1 + 0i$	$1 + 0i$	$-0.707 - 0.707i$	$0.707 + 0.707i$	$-0.707 - 0.707i$
6	$-1 + 0i$	$-1 + 0i$	$1 + 0i$	$1 + 0i$	$-0.707 - 0.707i$	$0.707 - 0.707i$
7	$1 + 0i$	$1 + 0i$	$1 + 0i$	$0.707 + 0.707i$	$-0.707 + 0.707i$	$-0.707 - 0.707i$
8	$1 + 0i$	$1 + 0i$	$-1 + 0i$	$-0.707 - 0.707i$	$-0.707 + 0.707i$	$-0.707 - 0.707i$

**Table L.11—Complete packet in the frequency domain (first and last three symbols)
(continued)**

Subcarrier	Symbol 1	Symbol 2	Symbol 3	Symbol 17	Symbol 18	Symbol 19
9	$-1 + 0i$	$-1 + 0i$	$1 + 0i$	$-0.707 - 0.707i$	$0.707 + 0.707i$	$0.707 - 0.707i$
10	$-1 + 0i$	$1 + 0i$	$-1 + 0i$	$0.707 + 0.707i$	$0.707 - 0.707i$	$-1 + 0i$
11	$-1 + 0i$	$-1 + 0i$	$-1 + 0i$	$0.707 - 0.707i$	$-0.707 - 0.707i$	$0.707 + 0.707i$
12	$1 + 0i$	$-1 + 0i$	$1 + 0i$	$-0.707 - 0.707i$	$-0.707 - 0.707i$	$-0.707 - 0.707i$
13	$-1 + 0i$	$1 + 0i$	$1 + 0i$	$0.707 - 0.707i$	$-0.707 - 0.707i$	$-0.707 + 0.707i$
14	$-1 + 0i$	$1 + 0i$	$1 + 0i$	$0.707 + 0.707i$	$0.707 + 0.707i$	$-0.707 - 0.707i$
15	$0 - 1i$	$-1 + 0i$	$0 - 1i$	$0.707 + 0.707i$	$0.707 + 0.707i$	$0.707 - 0.707i$
16	$-1 + 0i$	$0 + 1i$	$1 + 0i$	$0.707 + 0.707i$	$-0.707 + 0.707i$	$-0.707 - 0.707i$
17	$0 + 1i$	$1 + 0i$	$0 - 1i$	$0.707 - 0.707i$	$-0.707 - 0.707i$	$-0.707 + 0.707i$
18	$-1 + 0i$	$0 + 1i$	$1 + 0i$	$1 + 0i$	$0.707 + 0.707i$	$0.707 + 0.707i$
19	$0 - 1i$	$-1 + 0i$	$1 + 0i$	$-0.707 + 0.707i$	$-0.707 - 0.707i$	$0.707 + 0.707i$
20	$-1 + 0i$	$0 + 1i$	$0 + 1i$	$0.707 - 0.707i$	$-0.707 - 0.707i$	$0.707 - 0.707i$
21	$0 - 1i$	$-1 + 0i$	$1 + 0i$	$-0.707 - 0.707i$	$0.707 + 0.707i$	$-0.707 - 0.707i$
22	$-1 + 0i$	$0 + 1i$	$0 - 1i$	$-0.707 - 0.707i$	$0.707 - 0.707i$	$1 + 0i$
23	$-1 + 0i$	$1 + 0i$	$-1 + 0i$	$0.707 + 0.707i$	$0.707 - 0.707i$	$0.707 + 0.707i$
24	$0 - 1i$	$0 - 1i$	$0 - 1i$	$0.707 - 0.707i$	$0.707 + 0.707i$	$0.707 - 0.707i$
25	$-1 + 0i$	$1 + 0i$	$-1 + 0i$	$0.707 + 0.707i$	$0.707 - 0.707i$	$-0.707 - 0.707i$
26	$0 + 1i$	$0 - 1i$	$0 - 1i$	$-0.707 + 0.707i$	$-1 + 0i$	$-0.707 + 0.707i$
27	<i>$0 + 0i$</i>	<i>$0 + 0i$</i>	<i>$0 + 0i$</i>	<i>$0 + 0i$</i>	<i>$0 + 0i$</i>	<i>$0 + 0i$</i>
28	<i>$0 + 0i$</i>	<i>$0 + 0i$</i>	<i>$0 + 0i$</i>	<i>$0 + 0i$</i>	<i>$0 + 0i$</i>	<i>$0 + 0i$</i>
29	<i>$0 + 0i$</i>	<i>$0 + 0i$</i>	<i>$0 + 0i$</i>	<i>$0 + 0i$</i>	<i>$0 + 0i$</i>	<i>$0 + 0i$</i>
30	<i>$0 + 0i$</i>	<i>$0 + 0i$</i>	<i>$0 + 0i$</i>	<i>$0 + 0i$</i>	<i>$0 + 0i$</i>	<i>$0 + 0i$</i>
31	<i>$0 + 0i$</i>	<i>$0 + 0i$</i>	<i>$0 + 0i$</i>	<i>$0 + 0i$</i>	<i>$0 + 0i$</i>	<i>$0 + 0i$</i>

NOTE—In Table L.11, the pilot tones are represented in **bold text** and the DC/guard tones are represented in *italic text*.

L.5.2 Time domain OFDM header and payload

The data from Table L.11 is converted by an IFFT of size 64. Most IFFTs require a reordering of the data. Typically, the order of the frequencies within each symbol should be as follows:

$$0, 1, 2, \dots, 31, -32, -31, \dots, -1$$

After the IFFT, each symbol is extended by a CP of 16 samples. Each OFDM symbol then has a size of 80 samples (64 + 16).

The resulting data in the time domain has 1520 samples (19×80) and is represented in L.7 (complete packet).

L.6 Generation of the preamble

L.6.1 Generation of the STF

As defined in 18.2.1.1, the STF consists of 4 symbols. The resulting STF is equivalent to 20 repetitions of the 16-sample time domain pattern given in Table L.12.

Table L.12—STF time domain pattern

Sample #	I	Q
1	0.6505	0
2	1.0989	0.6505
3	0.46	-1.301
4	-0.9531	-0.6505
5	0	0
6	0.9531	0.6505
7	-0.46	1.301
8	-1.0989	-0.6505
9	-0.6505	0
10	-1.0989	0.6505
11	-0.46	-1.301
12	0.9531	-0.6505
13	0	0
14	-0.9531	0.6505
15	0.46	1.301
16	1.0989	-0.6505

NOTE—The last 2 repetitions are negated.

L.6.2 Generation of the LTF

As defined in 18.2.1.2, the LTF consists of the time domain pattern given in Table L.13.

The samples 1 through 32 are part of the CP for the LTF. They are simply a copy of samples 65 through 96. The samples 97 through 160 are a repetition of samples 33 through 96.

Table L.13—LTF in time domain

Sample #	I	Q	Sample #	I	Q
33	-0.75	0	65	1.25	0
34	0.5069	-0.5395	66	-0.3216	-0.5171
35	0.147	0.178	67	-0.564	-0.4328
36	-0.5541	0.4205	68	0.8594	0.5478
37	0.2817	-0.9077	69	0.0111	-0.4458
38	-0.5326	0.3518	70	-0.9756	-0.4563
39	-0.3165	1.0258	71	-1.1903	0.3727
40	-0.5391	0.207	72	-0.7761	-0.0741
41	-0.6036	1.1339	73	0.1036	-0.6339
42	0.8113	0.6423	74	0.2871	-1.2165
43	-0.6222	-0.3373	75	0.4219	-0.6784
44	-0.4653	-0.3832	76	0.8836	-0.4284
45	1.1802	0.4189	77	0.5269	0.2276
46	0.0015	1.1597	78	-0.6312	0.5158
47	0.4623	0.2948	79	-0.3382	-0.9638
48	1.0998	-0.4827	80	0.3459	0.1333
49	0.25	-1.25	81	0.25	1.25
50	0.3459	-0.1333	82	1.0998	0.4827
51	-0.3382	0.9638	83	0.4623	-0.2948
52	-0.6312	-0.5158	84	0.0015	-1.1597
53	0.5269	-0.2276	85	1.1802	-0.4189
54	0.8836	0.4284	86	-0.4653	0.3832
55	0.4219	0.6784	87	-0.6222	0.3373
56	0.2871	1.2165	88	0.8113	-0.6423
57	0.1036	0.6339	89	-0.6036	-1.1339
58	-0.7761	0.0741	90	-0.5391	-0.207
59	-1.1903	-0.3727	91	-0.3165	-1.0258
60	-0.9756	0.4563	92	-0.5326	-0.3518
61	0.0111	0.4458	93	0.2817	0.9077
62	0.8594	-0.5478	94	-0.5541	-0.4205
63	-0.564	0.4328	95	0.147	-0.178
64	-0.3216	0.5171	96	0.5069	0.5395

L.7 The entire packet

The complete packet in the time domain is represented in Table L.14. The STF is from sample 1 to 320. The LTF is from sample 321 to 480. The OFDM header and payload are from sample 481 to 2000.

Table L.14—Complete packet

Sample	I	Q	Sample	I	Q	Sample	I	Q	Sample	I	Q
1	0.6505	0	501	-0.3152	-0.0032	1001	-0.2589	0.125	1501	1.0879	-0.1802
2	1.0989	0.6505	502	-0.7019	0.7465	1002	0.0957	-0.0742	1502	0.5504	-1.0303
3	0.46	-1.301	503	0.3034	-0.3115	1003	1.3264	-0.645	1503	-0.353	-1.0804
4	-0.9531	-0.6505	504	0.2617	-0.0489	1004	0.3176	-0.1546	1504	-0.1305	0.2871
5	0	0	505	-0.4053	0.6553	1005	0.3753	-0.1902	1505	0.0732	0.7071
6	0.9531	0.6505	506	0.9183	-0.0648	1006	0.1755	0.693	1506	-0.1505	0.1106
7	-0.46	1.301	507	0.4545	0.023	1007	-0.1535	1.4903	1507	0.7487	-0.2539
8	-1.0989	-0.6505	508	-0.1544	0.4795	1008	0.2928	-0.4478	1508	0.5702	-0.3195
9	-0.6505	0	509	-0.865	0.7468	1009	0.3536	-0.8839	1509	0.2407	-0.4889
10	-1.0989	0.6505	510	-0.4766	0.1583	1010	0.3706	0.447	1510	1.4049	0.235
11	-0.46	-1.301	511	0.7769	-0.9179	1011	-1.0583	0.5522	1511	0.267	0.8823
12	0.9531	-0.6505	512	-0.3158	-0.6323	1012	0.014	0.5397	1512	-0.1098	0.5457
13	0	0	513	1	-0.5	1013	0.6459	-0.24	1513	0	0.4571
14	-0.9531	0.6505	514	1.1294	-0.9673	1014	-1.6167	-1.0935	1514	-1.0648	0.1166
15	0.46	1.301	515	-0.475	-0.0292	1015	-0.6615	-0.6868	1515	-0.1968	0.4275
16	1.0989	-0.6505	516	0.7496	1.1095	1016	-0.4196	-0.3639	1516	-0.2262	0.5005
17	0.6505	0	517	0.2962	-0.2072	1017	-0.9053	0.3321	1517	-0.1371	-0.9889
18	1.0989	0.6505	518	0.61	-1.2555	1018	-0.5822	0.2493	1518	0.9962	-0.8207
19	0.46	-1.301	519	0.9438	0.2525	1019	-0.9506	-0.6197	1519	0.7019	0.0296
20	-0.9531	-0.6505	520	-0.3988	0.1504	1020	0.4131	0.1353	1520	-0.2743	0.2598
21	0	0	521	0.125	-0.5821	1021	-0.2272	0.0676	1521	0.6036	0
22	0.9531	0.6505	522	0.2185	0.1985	1022	-0.5896	-0.5819	1522	-0.7102	0.0582
23	-0.46	1.301	523	0.723	-0.2595	1023	0.7024	0.5376	1523	-0.8069	0.0666
24	-1.0989	-0.6505	524	0.7028	0.3073	1024	-0.9078	0.6814	1524	0.7677	0.5468
25	-0.6505	0	525	-0.1721	1.0608	1025	-0.8839	0.3536	1525	0.2524	0.3515
26	-1.0989	0.6505	526	0.1245	-0.6063	1026	-0.0336	0.8687	1526	0.0091	1.0895
27	-0.46	-1.301	527	-0.0681	-0.9558	1027	-0.7799	0.1728	1527	-0.0781	1.2938
28	0.9531	-0.6505	528	0.0339	-0.7114	1028	0.1891	-0.6159	1528	0.2749	0.1756
29	0	0	529	-1.25	-0.75	1029	0.6734	-0.4006	1529	0.4268	-0.7071
30	-0.9531	0.6505	530	-1.6118	0.2379	1030	0.2461	0.05	1530	-0.6077	-1.4293
31	0.46	1.301	531	0.1999	0.4937	1031	1.184	0.4273	1531	0.563	-0.6991
32	1.0989	-0.6505	532	-0.5909	0.2326	1032	0.4654	0.1181	1532	0.8327	-0.8248
33	0.6505	0	533	-0.6419	-0.6004	1033	-1.5089	-0.125	1533	-0.4415	-1.0406

Table L.14—Complete packet (continued)

Sample	I	Q	Sample	I	Q	Sample	I	Q	Sample	I	Q
34	1.0989	0.6505	534	0.3993	-0.7404	1034	-0.2443	-0.146	1534	-0.1301	-0.7419
35	0.46	-1.301	535	0.1517	0.8183	1035	0.7714	-0.6208	1535	-0.196	-1.2772
36	-0.9531	-0.6505	536	0.3911	0.5603	1036	-0.6118	-0.675	1536	0.6182	0.3049
37	0	0	537	0.6553	-0.4053	1037	-0.8753	-0.5169	1537	0.8107	0.3536
38	0.9531	0.6505	538	0.2064	0.0022	1038	-0.5449	-0.4082	1538	-0.257	-1.3845
39	-0.46	1.301	539	-0.1681	-0.023	1039	0.4193	0.2374	1539	0.5271	-0.5753
40	-1.0989	-0.6505	540	0.6483	-0.2591	1040	1.6786	0.8281	1540	-0.0303	0.2553
41	-0.6505	0	541	0.115	0.1496	1041	-1.3839	-0.1768	1541	-0.6329	-0.3224
42	-1.0989	0.6505	542	-0.2533	0.6345	1042	-0.6704	0.5355	1542	0.3853	-0.5783
43	-0.46	-1.301	543	1.0385	-0.2063	1043	0.5092	-0.4634	1543	0.2062	1.2063
44	0.9531	-0.6505	544	0.207	-0.7164	1044	-0.9994	0.5225	1544	0.5346	1.3008
45	0	0	545	0.75	0.75	1045	0.1117	0.5856	1545	0.7803	-0.3964
46	-0.9531	0.6505	546	0.7478	0.8804	1046	0.6351	0.1888	1546	0.1151	0.3834
47	0.46	1.301	547	-1.8473	0.0292	1047	-0.6357	-0.2362	1547	-0.634	0.429
48	1.0989	-0.6505	548	-1.0324	0.3448	1048	-0.1339	0.1905	1548	-0.6766	0.0394
49	0.6505	0	549	0.1609	0.3108	1049	-0.7286	0.9786	1549	0.7144	0.1713
50	1.0989	0.6505	550	0.1388	-0.4451	1050	-0.7351	-0.3456	1550	-0.0891	-0.0131
51	0.46	-1.301	551	-0.106	-1.0522	1051	0.1451	-0.4809	1551	-0.4727	0.2019
52	-0.9531	-0.6505	552	-0.8661	-0.2156	1052	-0.1864	0.2875	1552	1.1123	-0.8002
53	0	0	553	0.125	0.8321	1053	0.0341	0.222	1553	-0.1036	-0.3536
54	0.9531	0.6505	554	0.1346	0.4	1054	-0.7802	-0.3408	1554	0.1428	0.8731
55	-0.46	1.301	555	-0.5951	0.2595	1055	-0.2768	-0.5178	1555	0.6424	0.5755
56	-1.0989	-0.6505	556	-0.1195	0.4088	1056	1.9581	0.5282	1556	-1.5436	0.1857
57	-0.6505	0	557	-0.5779	0.5428	1057	0.5	0.3536	1557	-0.2095	-0.9551
58	-1.0989	0.6505	558	-0.255	0.5079	1058	-0.7115	0.0462	1558	0.6815	-0.8154
59	-0.46	-1.301	559	0.9598	0.3728	1059	0.7485	0.6712	1559	-0.7935	0.195
60	0.9531	-0.6505	560	-0.313	1.1997	1060	1.0929	0.5474	1560	0.0674	0.3238
61	0	0	561	-0.5	0.5	1061	1.014	-0.4339	1561	-0.0732	-0.2071
62	-0.9531	0.6505	562	-0.0269	0.5835	1062	0.7941	-1.4585	1562	-0.3058	-0.3181
63	0.46	1.301	563	0.3762	0.8987	1063	0.2306	-1.0711	1563	1.041	1.3381
64	1.0989	-0.6505	564	-0.3916	-0.3543	1064	0.234	-0.4601	1564	0.2113	0.5691
65	0.6505	0	565	-1.6311	0.0394	1065	0.0214	-0.125	1565	-1.0156	-0.77
66	1.0989	0.6505	566	-0.1295	0.5707	1066	-0.3034	0.1486	1566	-0.5914	-0.0458
67	0.46	-1.301	567	0.8723	-0.5243	1067	0.1528	0.2707	1567	-0.4842	-0.3492
68	-0.9531	-0.6505	568	0.4785	-0.803	1068	0.3789	0.3591	1568	-0.6408	0.3395
69	0	0	569	0.7286	-0.625	1069	-0.2942	-0.6443	1569	0.1036	0.7071
70	0.9531	0.6505	570	0.4153	0.5426	1070	-0.142	-0.377	1570	0.8656	-0.1366

Table L.14—Complete packet (continued)

Sample	I	Q	Sample	I	Q	Sample	I	Q	Sample	I	Q
71	-0.46	1.301	571	0.4098	-0.5751	1071	0.2126	0.3483	1571	0.3444	-0.3598
72	-1.0989	-0.6505	572	0.3124	-1.6609	1072	-0.2751	0.0058	1572	-1.0004	-0.398
73	-0.6505	0	573	-0.2547	0.4696	1073	0.3839	0.1768	1573	-0.8242	0.2188
74	-1.0989	0.6505	574	-0.4437	-0.331	1074	0.7601	-0.1322	1574	0.7306	0.0209
75	-0.46	-1.301	575	-0.8561	-0.5979	1075	-0.3385	0.5893	1575	-0.0417	0.0119
76	0.9531	-0.6505	576	-0.1274	0.6406	1076	-0.1832	0.437	1576	-0.9181	0.3307
77	0	0	577	0.25	0.25	1077	0.7418	-0.5856	1577	0.2803	0.6036
78	-0.9531	0.6505	578	-0.3854	0.0544	1078	0.3944	1.0648	1578	-0.2429	1.5395
79	0.46	1.301	579	0.2915	-1.0776	1079	-0.0763	1.0342	1579	-0.263	0.6391
80	1.0989	-0.6505	580	-0.1043	-0.2086	1080	0.6077	-0.1183	1580	0.4391	0.0407
81	0.6505	0	581	-0.7177	0.1911	1081	0.0214	-0.2714	1581	-0.6715	-0.482
82	1.0989	0.6505	582	0.0456	-0.867	1082	-1.594	-0.9907	1582	0.004	-1.3302
83	0.46	-1.301	583	-0.6118	0.5262	1083	-0.5865	-0.3521	1583	0.4458	0.1316
84	-0.9531	-0.6505	584	-0.5278	0.3099	1084	0.2947	0.8838	1584	-0.0485	0.4391
85	0	0	585	1.0518	0.5518	1085	-0.1805	0.278	1585	0.6036	0
86	0.9531	0.6505	586	0.4187	0.5543	1086	0.4864	-0.6731	1586	-0.7102	0.0582
87	-0.46	1.301	587	-0.9184	-0.3628	1087	0.3354	0.9681	1587	-0.8069	0.0666
88	-1.0989	-0.6505	588	-0.2459	1.5139	1088	0.206	0.9803	1588	0.7677	0.5468
89	-0.6505	0	589	-0.1882	0.3201	1089	0.5	-1.0607	1589	0.2524	0.3515
90	-1.0989	0.6505	590	-1.2673	-1.1614	1090	-0.3908	-0.0033	1590	0.0091	1.0895
91	-0.46	-1.301	591	-0.1584	0.0777	1091	-0.4192	-0.0042	1591	-0.0781	1.2938
92	0.9531	-0.6505	592	0.4695	-0.3782	1092	-0.7392	-0.0292	1592	0.2749	0.1756
93	0	0	593	-0.75	-0.25	1093	-1.1604	0.4339	1593	0.4268	-0.7071
94	-0.9531	0.6505	594	-0.1427	-0.3528	1094	0.0053	-1.2729	1594	-0.6077	-1.4293
95	0.46	1.301	595	0.36	-1.2903	1095	-0.0186	-0.5198	1595	0.563	-0.6991
96	1.0989	-0.6505	596	0.3983	-0.2296	1096	-0.6952	-0.0583	1596	0.8327	-0.8248
97	0.6505	0	597	0.7346	1.2106	1097	-0.7286	0.125	1597	-0.4415	-1.0406
98	1.0989	0.6505	598	-0.5309	-0.1371	1098	-0.769	0.3274	1598	-0.1301	-0.7419
99	0.46	-1.301	599	-0.4358	-1.3615	1099	-0.2115	-1.6448	1599	-0.196	-1.2772
100	-0.9531	-0.6505	600	0.3291	-0.1385	1100	0.756	-0.5939	1600	0.6182	0.3049
101	0	0	601	0.0214	-0.625	1101	1.1477	0.1443	1601	0.3536	0.7071
102	0.9531	0.6505	602	0.7796	-0.5223	1102	0.1926	0.4544	1602	-0.3547	0.6356
103	-0.46	1.301	603	0.1606	0.2373	1103	0.2288	1.4085	1603	0.0026	-0.5089
104	-1.0989	-0.6505	604	-0.6509	-0.4224	1104	0.5126	-0.6539	1604	0.4591	-0.9793
105	-0.6505	0	605	0.1512	0.9875	1105	-1.3839	-0.1768	1605	0.0269	-0.2041
106	-1.0989	0.6505	606	-0.5091	0.6844	1106	-0.6704	0.5355	1606	-1.055	0.1967
107	-0.46	-1.301	607	-0.5042	-0.4761	1107	0.5092	-0.4634	1607	0.5081	0.1146

Table L.14—Complete packet (continued)

Sample	I	Q	Sample	I	Q	Sample	I	Q	Sample	I	Q
108	0.9531	-0.6505	608	0.795	0.3131	1108	-0.9994	0.5225	1608	1.3278	-0.1783
109	0	0	609	0.5	0	1109	0.1117	0.5856	1609	-0.7803	-0.6036
110	-0.9531	0.6505	610	-0.315	0.1515	1110	0.6351	0.1888	1610	0.0162	-0.7913
111	0.46	1.301	611	-0.3206	-0.2379	1111	-0.6357	-0.2362	1611	-0.0462	-0.069
112	1.0989	-0.6505	612	-0.3389	-0.1851	1112	-0.1339	0.1905	1612	0.1889	0.9928
113	0.6505	0	613	-0.8858	1.0589	1113	-0.7286	0.9786	1613	0.9413	0.1226
114	1.0989	0.6505	614	0.0198	0.3796	1114	-0.7351	-0.3456	1614	-1.4154	-0.4991
115	0.46	-1.301	615	1.5895	0.3596	1115	0.1451	-0.4809	1615	-0.5254	0.8781
116	-0.9531	-0.6505	616	1.0805	0.6855	1116	-0.1864	0.2875	1616	-0.0592	0.0519
117	0	0	617	0.6982	0.1982	1117	0.0341	0.222	1617	-0.3536	-1.4142
118	0.9531	0.6505	618	0.6706	0.4031	1118	-0.7802	-0.3408	1618	1.2199	-0.1272
119	-0.46	1.301	619	-0.359	0.4077	1119	-0.2768	-0.5178	1619	-0.1617	0.5988
120	-1.0989	-0.6505	620	-0.3933	0.1329	1120	1.9581	0.5282	1620	0.1019	0.3871
121	-0.6505	0	621	0.7917	-0.2772	1121	1.3107	0.7071	1621	0.4889	0.3932
122	-1.0989	0.6505	622	1.4009	-0.5524	1122	0.4326	0.6513	1622	-0.3196	0.2501
123	-0.46	-1.301	623	0.1046	-0.0037	1123	-1.0584	0.2543	1623	0.4854	0.711
124	0.9531	-0.6505	624	-1.0834	0.785	1124	0.0874	0.4525	1624	-0.6103	0.0647
125	0	0	625	-0.5	0.5	1125	1.3684	0.2468	1625	-0.6768	-0.6036
126	-0.9531	0.6505	626	-0.0269	0.5835	1126	0.3107	0.0857	1626	-0.1627	0.5331
127	0.46	1.301	627	0.3762	0.8987	1127	-0.3262	0.6729	1627	-0.4069	0.0439
128	1.0989	-0.6505	628	-0.3916	-0.3543	1128	-0.4839	0.6139	1628	0.1342	-0.7233
129	0.6505	0	629	-1.6311	0.0394	1129	-1.125	1.2286	1629	-0.2881	0.4492
130	1.0989	0.6505	630	-0.1295	0.5707	1130	-0.324	-0.0743	1630	0.4181	0.5584
131	0.46	-1.301	631	0.8723	-0.5243	1131	0.4623	-0.8069	1631	0.8552	0.0761
132	-0.9531	-0.6505	632	0.4785	-0.803	1132	-0.1397	1.1748	1632	0.3919	-0.0307
133	0	0	633	0.7286	-0.625	1133	-0.7499	-0.6194	1633	0.7071	-0.7071
134	0.9531	0.6505	634	0.4153	0.5426	1134	-0.1972	-0.7251	1634	0.2109	-1.4097
135	-0.46	1.301	635	0.4098	-0.5751	1135	0.9637	0.5971	1635	0.268	-1.4598
136	-1.0989	-0.6505	636	0.3124	-1.6609	1136	0.4623	-0.5046	1636	0.9103	0.0464
137	-0.6505	0	637	-0.2547	0.4696	1137	0.2803	1.2374	1637	0.6802	0.9112
138	-1.0989	0.6505	638	-0.4437	-0.331	1138	1.0275	0.5272	1638	-0.5451	-0.4129
139	-0.46	-1.301	639	-0.8561	-0.5979	1139	0.0113	-0.9355	1639	-0.2787	-0.9936
140	0.9531	-0.6505	640	-0.1274	0.6406	1140	-0.6204	0.7613	1640	1.0654	-1.368
141	0	0	641	0.25	-0.5	1141	-0.89	0.3108	1641	-0.2803	-1.1036
142	-0.9531	0.6505	642	0.403	-0.2371	1142	-1.2452	-0.4992	1642	-0.6351	1.079
143	0.46	1.301	643	1.0226	-0.1746	1143	-0.3086	-1.0016	1643	0.3168	0.6773
144	1.0989	-0.6505	644	-0.1153	0.1551	1144	-0.1656	-0.5035	1644	0.2175	-0.7115

Table L.14—Complete packet (continued)

Sample	I	Q	Sample	I	Q	Sample	I	Q	Sample	I	Q
145	0.6505	0	645	0.4778	-0.134	1145	0.2714	0.625	1645	0.5587	0.5845
146	1.0989	0.6505	646	0.4828	-0.8943	1146	0.4795	0.083	1646	-0.004	0.698
147	0.46	-1.301	647	0.2801	0.123	1147	-0.6645	-0.1462	1647	-0.2452	-0.1038
148	-0.9531	-0.6505	648	-0.0148	1.1609	1148	-0.0025	-0.0595	1648	-0.2382	0.1114
149	0	0	649	-0.375	0.7286	1149	-0.1067	0.7151	1649	-0.7071	0
150	0.9531	0.6505	650	0.7524	0.5096	1150	-0.852	0.3955	1650	0.0234	0.1846
151	-0.46	1.301	651	-0.8567	0.3234	1151	0.5795	-0.6363	1651	-0.1089	-0.3372
152	-1.0989	-0.6505	652	-0.7367	-0.2166	1152	0.8012	0.0835	1652	-0.4989	-1.0441
153	-0.6505	0	653	1.2458	-0.0193	1153	0.25	0.3536	1653	0.2183	0.3139
154	-1.0989	0.6505	654	0.2994	0.2395	1154	0.3127	0.5918	1654	0.1714	0.7904
155	-0.46	-1.301	655	0.4325	-0.1663	1155	0.4818	-0.2727	1655	0.2852	-0.1249
156	0.9531	-0.6505	656	0.5498	-1.1755	1156	0.6819	-0.8599	1656	1.272	0.3506
157	0	0	657	0.5	-1.25	1157	-0.2648	-0.3504	1657	0.3232	0.8964
158	-0.9531	0.6505	658	0.3124	0.9187	1158	-0.2811	-1.3707	1658	-0.7321	0.3101
159	0.46	1.301	659	-0.3425	0.7625	1159	0.148	-0.1343	1659	0.1363	-0.3594
160	1.0989	-0.6505	660	0.5529	-1.2669	1160	0.0583	0.9129	1660	-1.0988	-0.3824
161	0.6505	0	661	-0.0529	-0.1736	1161	1.125	-0.0214	1661	-1.2119	0.2579
162	1.0989	0.6505	662	-0.4119	-0.0433	1162	0.6191	-0.3148	1662	0.3354	0.8325
163	0.46	-1.301	663	-0.5436	-0.9554	1163	-0.077	-1.3215	1663	-1.0846	0.8567
164	-0.9531	-0.6505	664	-1.8697	0.0768	1164	0.1305	-0.7331	1664	-0.7351	0.5842
165	0	0	665	-0.5518	-0.3018	1165	-1.2679	-0.4841	1665	0.3536	0.7071
166	0.9531	0.6505	666	1.1419	-0.446	1166	-0.4491	-0.5243	1666	-0.3547	0.6356
167	-0.46	1.301	667	0.8086	0.1402	1167	0.8201	0.9034	1667	0.0026	-0.5089
168	-1.0989	-0.6505	668	-0.1808	-0.1731	1168	-0.92	-0.1987	1668	0.4591	-0.9793
169	-0.6505	0	669	0.3092	0.347	1169	-1.1339	-0.1768	1669	0.0269	-0.2041
170	-1.0989	0.6505	670	0.7407	-0.2839	1170	-0.1195	1.1895	1670	-1.055	0.1967
171	-0.46	-1.301	671	-0.4095	-0.6668	1171	0.0654	0.0396	1671	0.5081	0.1146
172	0.9531	-0.6505	672	0.324	0.6626	1172	0.1217	-0.6245	1672	1.3278	-0.1783
173	0	0	673	0	0.75	1173	-0.2135	-0.2072	1673	-0.7803	-0.6036
174	-0.9531	0.6505	674	-0.8544	0.7334	1174	-0.0551	-0.0275	1674	0.0162	-0.7913
175	0.46	1.301	675	0.5255	0.2195	1175	0.4011	-0.037	1675	-0.0462	-0.069
176	1.0989	-0.6505	676	-0.2896	-0.4108	1176	-0.0622	-0.37	1676	0.1889	0.9928
177	0.6505	0	677	-0.5814	0.384	1177	-0.9786	-1.125	1677	0.9413	0.1226
178	1.0989	0.6505	678	0.7117	0.4746	1178	-0.4279	-0.6538	1678	-1.4154	-0.4991
179	0.46	-1.301	679	-0.2389	0.6096	1179	0.7792	0.3604	1679	-0.5254	0.8781
180	-0.9531	-0.6505	680	-0.8804	0.3611	1180	-0.259	-0.1115	1680	-0.0592	0.0519
181	0	0	681	-0.375	0.0214	1181	-0.7039	0.3885	1681	-0.6036	-1.0607

Table L.14—Complete packet (continued)

Sample	I	Q	Sample	I	Q	Sample	I	Q	Sample	I	Q
182	0.9531	0.6505	682	-0.8699	0.7716	1182	0.7688	0.6657	1682	-0.1873	1.0237
183	-0.46	1.301	683	-0.5328	-0.715	1183	0.5509	-0.3642	1683	0.8265	-0.1228
184	-1.0989	-0.6505	684	0.5481	-1.3786	1184	0.3098	-0.0335	1684	0.222	-0.2516
185	-0.6505	0	685	-0.8493	0.7693	1185	1.3107	0.7071	1685	-0.5957	1.0412
186	-1.0989	0.6505	686	-1.1144	1.3178	1186	0.4326	0.6513	1686	-0.63	-0.2629
187	-0.46	-1.301	687	0.374	1.0109	1187	-1.0584	0.2543	1687	-0.7386	-0.1001
188	0.9531	-0.6505	688	0.1823	0.6881	1188	0.0874	0.4525	1688	-0.468	-0.2202
189	0	0	689	0.75	0.5	1189	1.3684	0.2468	1689	-0.1036	-0.2803
190	-0.9531	0.6505	690	0.3684	0.0626	1190	0.3107	0.0857	1690	0.2743	0.6838
191	0.46	1.301	691	-0.4985	-1.1002	1191	-0.3262	0.6729	1691	-0.2272	0.1516
192	1.0989	-0.6505	692	0.5538	-0.1209	1192	-0.4839	0.6139	1692	-0.5012	0.4163
193	0.6505	0	693	0.6564	0.4236	1193	-1.125	1.2286	1693	0.3932	-0.3853
194	1.0989	0.6505	694	0.3707	-0.3974	1194	-0.324	-0.0743	1694	0.1315	-1.2505
195	0.46	-1.301	695	-0.4976	0.2228	1195	0.4623	-0.8069	1695	-0.5593	0.524
196	-0.9531	-0.6505	696	-0.9433	-0.0313	1196	-0.1397	1.1748	1696	-0.7824	0.5917
197	0	0	697	-0.1982	0.0518	1197	-0.7499	-0.6194	1697	-0.1036	-0.7071
198	0.9531	0.6505	698	-0.2538	0.1013	1198	-0.1972	-0.7251	1698	0.139	-0.4854
199	-0.46	1.301	699	-0.1261	-1.4557	1199	0.9637	0.5971	1699	-0.4307	0.0293
200	-1.0989	-0.6505	700	0.0817	-0.4166	1200	0.4623	-0.5046	1700	0.9426	0.3115
201	-0.6505	0	701	0.7944	0.403	1201	0.5303	0.7071	1701	0.3774	1.1601
202	-1.0989	0.6505	702	-0.0791	-0.8272	1202	0.5446	-0.1371	1702	-0.9614	0.8328
203	-0.46	-1.301	703	-1.397	-0.1778	1203	-0.3343	-0.8645	1703	0.323	-0.0744
204	0.9531	-0.6505	704	0.2378	0.0857	1204	-0.2946	-1.1975	1704	-0.0895	0.6163
205	0	0	705	0.25	-0.5	1205	-0.6705	-1.132	1705	-0.6036	0.8232
206	-0.9531	0.6505	706	0.403	-0.2371	1206	-0.1481	-1.0283	1706	-0.2894	1.1625
207	0.46	1.301	707	1.0226	-0.1746	1207	0.131	0.3293	1707	-0.1444	1.1149
208	1.0989	-0.6505	708	-0.1153	0.1551	1208	-0.7444	1.1245	1708	0.3446	0.0746
209	0.6505	0	709	0.4778	-0.134	1209	-0.7803	-0.5303	1709	0.1495	0.9302
210	1.0989	0.6505	710	0.4828	-0.8943	1210	-0.5906	0.1619	1710	0.2154	0.3807
211	0.46	-1.301	711	0.2801	0.123	1211	-0.055	1.2353	1711	-0.7559	-1.4073
212	-0.9531	-0.6505	712	-0.0148	1.1609	1212	0.1562	-0.4363	1712	-0.5459	-1.1724
213	0	0	713	-0.375	0.7286	1213	0.0415	-0.8234	1713	0.8107	-0.7071
214	0.9531	0.6505	714	0.7524	0.5096	1214	0.1156	0.2344	1714	-0.2192	-0.0629
215	-0.46	1.301	715	-0.8567	0.3234	1215	0.7563	0.3465	1715	0.3062	-0.1527
216	-1.0989	-0.6505	716	-0.7367	-0.2166	1216	0.7471	-0.388	1716	0.5388	-0.5619
217	-0.6505	0	717	1.2458	-0.0193	1217	-0.8839	-0.3536	1717	-0.4043	-0.0412
218	-1.0989	0.6505	718	0.2994	0.2395	1218	0.6253	0.7563	1718	0.4096	-0.0019

Table L.14—Complete packet (continued)

Sample	I	Q	Sample	I	Q	Sample	I	Q	Sample	I	Q
219	−0.46	−1.301	719	0.4325	−0.1663	1219	1.4158	0.9756	1719	0.3353	0.2709
220	0.9531	−0.6505	720	0.5498	−1.1755	1220	−1.0077	−0.2102	1720	0.0644	−0.1024
221	0	0	721	1.25	0.25	1221	−0.0912	−0.6343	1721	−0.6036	−1.2803
222	−0.9531	0.6505	722	0.5896	−0.4771	1222	0.776	−0.2064	1722	−0.8985	−0.4891
223	0.46	1.301	723	0.2416	−0.9515	1223	0.7189	−0.2537	1723	−0.1401	−0.0391
224	1.0989	−0.6505	724	−0.3164	−0.4676	1224	0.8175	0.1801	1724	−0.4531	−1.2599
225	0.6505	0	725	−0.1213	−0.4968	1225	−0.6339	−0.0732	1725	0.3139	−0.1147
226	1.0989	0.6505	726	−0.3094	−0.3462	1226	−0.0827	−0.1695	1726	0.6945	1.0481
227	0.46	−1.301	727	−0.6124	0.3067	1227	0.7858	1.0051	1727	0.5799	0.3413
228	−0.9531	−0.6505	728	0.6017	0.2498	1228	0.751	0.3911	1728	1.0788	0.9706
229	0	0	729	0.0518	0.0518	1229	0.5034	0.1723	1729	−0.1036	−0.3536
230	0.9531	0.6505	730	0.0178	−0.737	1230	0.1235	0.1924	1730	−0.1203	−0.9216
231	−0.46	1.301	731	−0.0622	−0.5425	1231	0.8943	−0.8946	1731	0.798	1.1604
232	−1.0989	−0.6505	732	−0.5637	0.8328	1232	0.212	0.0454	1732	0.3737	−0.9757
233	−0.6505	0	733	1.3807	0.4445	1233	−0.1768	0.3536	1733	−0.0845	−1.453
234	−1.0989	0.6505	734	−0.006	−0.3219	1234	−0.1183	−0.3198	1734	0.1046	0.9097
235	−0.46	−1.301	735	−0.6906	0.0269	1235	−0.6102	0.1182	1735	0.5803	0.4036
236	0.9531	−0.6505	736	1.3586	0.0224	1236	0.9278	−0.0763	1736	−0.119	0.1525
237	0	0	737	−0.25	−0.25	1237	0.524	−0.7822	1737	−0.1036	−0.6768
238	−0.9531	0.6505	738	−0.2619	0.8775	1238	−0.3646	−0.0952	1738	0.3015	−0.4968
239	0.46	1.301	739	1.06	1.1668	1239	0.3261	1.6188	1739	−0.9883	0.6868
240	1.0989	−0.6505	740	0.1949	−0.9882	1240	−0.7508	0.5659	1740	−0.4675	−0.1675
241	0.6505	0	741	−0.2424	−0.2928	1241	−0.2803	−0.5303	1741	1.2647	0.2769
242	1.0989	0.6505	742	−0.0352	1.424	1242	0.289	0.222	1742	1.0357	0.7582
243	0.46	−1.301	743	0.426	0.1328	1243	−1.2309	−0.5937	1743	0.2353	0.042
244	−0.9531	−0.6505	744	0.2041	0.185	1244	−0.7569	−0.1461	1744	−0.1384	−1.2503
245	0	0	745	−0.125	0.2286	1245	0.3121	−0.0908	1745	−0.6036	−1.0607
246	0.9531	0.6505	746	−0.1434	−0.1718	1246	0.4104	−0.9669	1746	−0.1873	1.0237
247	−0.46	1.301	747	−0.1389	0.8722	1247	0.2008	−0.5516	1747	0.8265	−0.1228
248	−1.0989	−0.6505	748	−0.2277	−0.2568	1248	−0.9587	−1.3755	1748	0.222	−0.2516
249	−0.6505	0	749	−0.0731	−0.5227	1249	−0.8839	0	1749	−0.5957	1.0412
250	−1.0989	0.6505	750	0.4728	1.0489	1250	0.1017	0.8539	1750	−0.63	−0.2629
251	−0.46	−1.301	751	−1.0327	0.1196	1251	0.0287	−1.0222	1751	−0.7386	−0.1001
252	0.9531	−0.6505	752	−0.7737	−1.0561	1252	1.1451	0.1721	1752	−0.468	−0.2202
253	0	0	753	1	−0.5	1253	0.9448	1.1343	1753	−0.1036	−0.2803
254	−0.9531	0.6505	754	−0.6231	0.6482	1254	−1.0338	0.5594	1754	0.2743	0.6838
255	0.46	1.301	755	−0.7036	−0.0845	1255	−0.2618	0.5126	1755	−0.2272	0.1516

Table L.14—Complete packet (continued)

Sample	I	Q	Sample	I	Q	Sample	I	Q	Sample	I	Q
256	1.0989	-0.6505	756	0.2741	-1.1065	1256	-0.4757	0.5893	1756	-0.5012	0.4163
257	0.6505	0	757	-0.3358	0.1004	1257	-1.1339	0.4268	1757	0.3932	-0.3853
258	1.0989	0.6505	758	-0.3413	-0.6247	1258	0.231	-0.3677	1758	0.1315	-1.2505
259	0.46	-1.301	759	0.0041	-1.0841	1259	0.0001	0.5604	1759	-0.5593	0.524
260	-0.9531	-0.6505	760	0.4098	0.3478	1260	0.079	0.5031	1760	-0.7824	0.5917
261	0	0	761	-0.3018	-0.3018	1261	-0.1499	-0.6723	1761	-1.4874	0.3536
262	0.9531	0.6505	762	-0.3041	-0.3038	1262	-0.879	0.3107	1762	-0.8989	0.4187
263	-0.46	1.301	763	0.2536	-0.6519	1263	0.0628	0.3068	1763	0.2643	-0.3137
264	-1.0989	-0.6505	764	0.1863	-1.3532	1264	0.1529	0.2583	1764	-0.5084	0.1167
265	-0.6505	0	765	0.7835	0.6591	1265	0.5303	0.7071	1765	-1.0687	0.403
266	-1.0989	0.6505	766	-0.1615	1.0382	1266	0.5446	-0.1371	1766	0.4622	-0.2318
267	-0.46	-1.301	767	-0.3543	0.444	1267	-0.3343	-0.8645	1767	-0.2149	0.7697
268	0.9531	-0.6505	768	-0.2568	0.0816	1268	-0.2946	-1.1975	1768	0.2876	0.3284
269	0	0	769	-1.5	-1	1269	-0.6705	-1.132	1769	0.9786	0.4482
270	-0.9531	0.6505	770	-0.8579	-0.0613	1270	-0.1481	-1.0283	1770	-0.2033	0.4965
271	0.46	1.301	771	-0.5981	-0.1308	1271	0.131	0.3293	1771	0.1658	-1.2037
272	1.0989	-0.6505	772	0.2936	-1.3118	1272	-0.7444	1.1245	1772	0.3518	-0.0415
273	0.6505	0	773	1.1995	-0.8108	1273	-0.7803	-0.5303	1773	0.5608	0.7043
274	1.0989	0.6505	774	-0.0847	-0.282	1274	-0.5906	0.1619	1774	0.1553	0.1143
275	0.46	-1.301	775	-0.1105	0.9376	1275	-0.055	1.2353	1775	-0.9012	0.4369
276	-0.9531	-0.6505	776	-0.279	0.9434	1276	0.1562	-0.4363	1776	0.328	-0.1142
277	0	0	777	-0.125	-0.4786	1277	0.0415	-0.8234	1777	0.9571	-0.1768
278	0.9531	0.6505	778	0.583	-0.1889	1278	0.1156	0.2344	1778	0.0343	0.6611
279	-0.46	1.301	779	-0.0524	0.3223	1279	0.7563	0.3465	1779	0.132	0.6966
280	-1.0989	-0.6505	780	-0.2553	0.8228	1280	0.7471	-0.388	1780	0.6536	-0.5701
281	-0.6505	0	781	-0.5911	0.9192	1281	0.1768	-0.1768	1781	0.2659	-0.4157
282	-1.0989	0.6505	782	-0.5347	0.4778	1282	1.1994	-0.1394	1782	-0.2429	0.4121
283	-0.46	-1.301	783	0.3705	1.1166	1283	0.7883	-0.8558	1783	-0.6262	-0.9135
284	0.9531	-0.6505	784	1.1496	1.0545	1284	0.1254	0.2224	1784	-0.4221	-0.1994
285	0	0	785	1.25	0.25	1285	0.4199	0.2061	1785	0.8321	0.8018
286	-0.9531	0.6505	786	0.5896	-0.4771	1286	-0.3473	-0.5966	1786	-0.1098	-0.7883
287	0.46	1.301	787	0.2416	-0.9515	1287	-0.5288	0.0012	1787	-1.0394	-0.4287
288	1.0989	-0.6505	788	-0.3164	-0.4676	1288	0.125	-0.0038	1788	0.2617	0.396
289	-0.6505	0	789	-0.1213	-0.4968	1289	0.6036	0.0732	1789	-0.0032	0.0409
290	-1.0989	-0.6505	790	-0.3094	-0.3462	1290	0.5678	0.2475	1790	-0.1526	0.7973
291	-0.46	1.301	791	-0.6124	0.3067	1291	-0.2018	-0.1097	1791	-0.4093	0.7031
292	0.9531	0.6505	792	0.6017	0.2498	1292	-1.002	0.4166	1792	-1.1569	-0.862

Table L.14—Complete packet (continued)

Sample	I	Q	Sample	I	Q	Sample	I	Q	Sample	I	Q
293	0	0	793	0.0518	0.0518	1293	-0.3908	-0.0597	1793	-0.0732	-0.3536
294	-0.9531	-0.6505	794	0.0178	-0.737	1294	0.7756	-1.0674	1794	0.1982	0.7375
295	0.46	-1.301	795	-0.0622	-0.5425	1295	-0.0966	-0.7552	1795	0.8536	-0.3871
296	1.0989	0.6505	796	-0.5637	0.8328	1296	0.0332	-1.0148	1796	1.4144	-0.5498
297	0.6505	0	797	1.3807	0.4445	1297	0.1768	-0.5303	1797	-0.742	0.347
298	1.0989	-0.6505	798	-0.006	-0.3219	1298	-1.6795	0.7331	1798	-0.9928	0.1588
299	0.46	1.301	799	-0.6906	0.0269	1299	-0.4548	0.078	1799	0.3296	-0.3776
300	-0.9531	0.6505	800	1.3586	0.0224	1300	0.7439	-0.3402	1800	-0.2746	-0.6705
301	0	0	801	-0.75	-0.5	1301	-0.6905	0.2827	1801	-0.2714	-0.3018
302	0.9531	-0.6505	802	0.6925	0.3787	1302	-0.4462	0.4112	1802	0.4763	0.146
303	-0.46	-1.301	803	0.49	-0.5588	1303	0.7675	0.3631	1803	0.3728	0.4649
304	-1.0989	0.6505	804	0.0296	-0.6947	1304	0.4473	-0.4132	1804	0.689	-0.3914
305	-0.6505	0	805	0.1239	0.7468	1305	-0.3964	-0.8839	1805	0.0428	-1.6614
306	-1.0989	-0.6505	806	0.4302	0.821	1306	-0.1079	0.2809	1806	-0.7666	-0.9068
307	-0.46	1.301	807	-0.7965	0.3	1307	-0.1765	0.7073	1807	0.0539	-0.3132
308	0.9531	0.6505	808	-0.7702	-0.1656	1308	0.3647	-0.481	1808	-0.3577	-0.0858
309	0	0	809	1.4053	0.4053	1309	0.3369	-0.6744	1809	-0.1036	0.1768
310	-0.9531	-0.6505	810	0.3555	1.2629	1310	-1.3011	0.5666	1810	0.1887	-0.0331
311	0.46	-1.301	811	-0.3756	1.0032	1311	-0.1621	0.5236	1811	-0.7499	-0.2029
312	1.0989	0.6505	812	-0.1669	0.606	1312	-0.0199	-0.1658	1812	0.7596	-0.8572
313	0.6505	0	813	-0.3919	-0.4857	1313	0.1768	0.8839	1813	0.1306	0.3728
314	1.0989	-0.6505	814	0.4783	-0.7561	1314	1.8818	1.1359	1814	-1.0869	0.9801
315	0.46	1.301	815	-0.8041	-0.0645	1315	0.1176	-0.1622	1815	1.0115	-0.2715
316	-0.9531	0.6505	816	-1.2097	-0.5419	1316	0.3212	-0.0358	1816	1.1933	0.0638
317	0	0	817	-0.25	0	1317	0.0372	0.3974	1817	0.5821	-0.9482
318	0.9531	-0.6505	818	-1.1991	0.684	1318	-1.2523	-0.096	1818	-0.0997	-1.2243
319	-0.46	-1.301	819	-0.5867	0.0665	1319	1.1261	-0.0446	1819	0.0008	-0.0396
320	-1.0989	0.6505	820	0.5047	0.4712	1320	0.5525	0.0939	1820	0.7925	-0.5169
321	1.25	0	821	-0.7581	0.5428	1321	0.1036	-0.4268	1821	-0.6004	0.2091
322	-0.3216	-0.5171	822	-1.1718	-0.626	1322	0.5888	-0.4527	1822	0.2101	1.0901
323	-0.564	-0.4328	823	0.1328	-1.1049	1323	-0.2422	0.2831	1823	0.7565	1.3804
324	0.8594	0.5478	824	-0.2339	-0.215	1324	0.5516	0.0729	1824	-1.1835	1.1254
325	0.0111	-0.4458	825	-0.125	1.0821	1325	-0.7734	-0.251	1825	-1.4874	0.3536
326	-0.9756	-0.4563	826	1.4165	0.6882	1326	-0.8906	0.9211	1826	-0.8989	0.4187
327	-1.1903	0.3727	827	0.4663	-0.5682	1327	-0.0387	0.827	1827	0.2643	-0.3137
328	-0.7761	-0.0741	828	-0.1519	-0.5003	1328	-1.2934	-0.1539	1828	-0.5084	0.1167
329	0.1036	-0.6339	829	0.5462	-0.2839	1329	-0.5303	0.5303	1829	-1.0687	0.403

Table L.14—Complete packet (continued)

Sample	I	Q	Sample	I	Q	Sample	I	Q	Sample	I	Q
330	0.2871	-1.2165	830	0.65	-0.3209	1330	0.0983	0.4014	1830	0.4622	-0.2318
331	0.4219	-0.6784	831	0.7639	0.6421	1331	0.5489	-0.06	1831	-0.2149	0.7697
332	0.8836	-0.4284	832	0.444	0.8517	1332	0.6161	0.3291	1832	0.2876	0.3284
333	0.5269	0.2276	833	0.5	-0.25	1333	0.2334	-0.1792	1833	0.9786	0.4482
334	-0.6312	0.5158	834	-0.4142	-0.2127	1334	0.5457	0.8712	1834	-0.2033	0.4965
335	-0.3382	-0.9638	835	-1.0935	0.0763	1335	-1.3648	2.0945	1835	0.1658	-1.2037
336	0.3459	0.1333	836	0.3203	0.1346	1336	-1.0836	0.0399	1836	0.3518	-0.0415
337	0.25	1.25	837	0.8332	0.1496	1337	1.1036	-0.8839	1837	0.5608	0.7043
338	1.0998	0.4827	838	0.6291	-1.301	1338	0.4514	0.2075	1838	0.1553	0.1143
339	0.4623	-0.2948	839	0.3588	-0.9125	1339	-0.3796	0.1194	1839	-0.9012	0.4369
340	0.0015	-1.1597	840	0.3187	0.544	1340	-0.7208	-0.5982	1840	0.328	-0.1142
341	1.1802	-0.4189	841	0.3447	-0.6553	1341	-0.5869	-1.1363	1841	0	0.1768
342	-0.4653	0.3832	842	0.5711	-0.6582	1342	-0.0839	-0.5959	1842	-0.0727	0.2687
343	-0.6222	0.3373	843	0.4791	0.0914	1343	0.2974	-0.1812	1843	0.7228	0.96
344	0.8113	-0.6423	844	-1.2386	-0.0474	1344	0.2389	-0.7964	1844	1.0263	1.2571
345	-0.6036	-1.1339	845	-0.0652	0.3821	1345	0.1768	-0.1768	1845	-0.2117	-0.4154
346	-0.5391	-0.207	846	0.6937	-0.5667	1346	1.1994	-0.1394	1846	-0.7483	-0.1364
347	-0.3165	-1.0258	847	-1.1061	-0.7109	1347	0.7883	-0.8558	1847	0.1785	0.1946
348	-0.5326	-0.3518	848	0.1804	-0.3041	1348	0.1254	0.2224	1848	0.7065	-0.5663
349	0.2817	0.9077	849	0	-0.75	1349	0.4199	0.2061	1849	-0.4053	0.4786
350	-0.5541	-0.4205	850	-0.8096	1.0641	1350	-0.3473	-0.5966	1850	-1.661	-0.0392
351	0.147	-0.178	851	-0.0168	0.916	1351	-0.5288	0.0012	1851	-0.4411	-0.4487
352	0.5069	0.5395	852	-0.4307	-0.4111	1352	0.125	-0.0038	1852	1.1159	0.2276
353	-0.75	0	853	0.301	1.0608	1353	0.6036	0.0732	1853	0.5193	-0.6912
354	0.5069	-0.5395	854	0.4539	0.1917	1354	0.5678	0.2475	1854	0.4769	-0.3546
355	0.147	0.178	855	0.5119	-1.1968	1355	-0.2018	-0.1097	1855	0.6412	0.4537
356	-0.5541	0.4205	856	0.5681	-0.6634	1356	-1.002	0.4166	1856	-0.8383	-0.039
357	0.2817	-0.9077	857	-0.125	-0.3321	1357	-0.3908	-0.0597	1857	-0.8839	0.7071
358	-0.5326	0.3518	858	0.3873	0.6213	1358	0.7756	-1.0674	1858	0.4013	0.8995
359	-0.3165	1.0258	859	-0.3628	-0.0264	1359	-0.0966	-0.7552	1859	0.3356	-0.6632
360	-0.5391	0.207	860	0.1335	-0.5583	1360	0.0332	-1.0148	1860	0.2511	0.149
361	-0.6036	1.1339	861	0.4109	0.8874	1361	-0.1036	-0.1768	1861	0.3074	0.3488
362	0.8113	0.6423	862	-1.1636	0.7296	1362	-0.5071	1.4348	1862	-0.4222	-1.3687
363	-0.6222	-0.3373	863	-0.0609	0.0475	1363	-0.2218	0.3474	1863	-0.667	-0.3525
364	-0.4653	-0.3832	864	-0.2974	-0.5057	1364	-0.4394	-0.5773	1864	-0.4294	-0.4603
365	1.1802	0.4189	865	-0.75	-0.5	1365	0.1678	-0.3457	1865	-0.5518	-0.375
366	0.0015	1.1597	866	0.6925	0.3787	1366	-0.0687	-0.7158	1866	-0.8671	1.2446

Table L.14—Complete packet (continued)

Sample	I	Q	Sample	I	Q	Sample	I	Q	Sample	I	Q
367	0.4623	0.2948	867	0.49	-0.5588	1367	0.1659	-0.3205	1867	-0.8479	-0.3663
368	1.0998	-0.4827	868	0.0296	-0.6947	1368	0.4969	-0.1672	1868	-0.3676	-1.0043
369	0.25	-1.25	869	0.1239	0.7468	1369	-0.2803	0.0732	1869	-0.153	-0.4651
370	0.3459	-0.1333	870	0.4302	0.821	1370	-0.4692	0.361	1870	0.4652	0.0878
371	-0.3382	0.9638	871	-0.7965	0.3	1371	-0.5611	-0.1364	1871	1.4612	0.7954
372	-0.6312	-0.5158	872	-0.7702	-0.1656	1372	-0.4332	-0.3624	1872	0.6684	0.2049
373	0.5269	-0.2276	873	1.4053	0.4053	1373	0.4743	-0.5845	1873	0	0.8839
374	0.8836	0.4284	874	0.3555	1.2629	1374	0.4699	-0.1637	1874	1.0586	-0.3127
375	0.4219	0.6784	875	-0.3756	1.0032	1375	-0.4154	-0.188	1875	0.2661	-0.7956
376	0.2871	1.2165	876	-0.1669	0.606	1376	-0.1374	-0.3935	1876	-1.3694	0.2729
377	0.1036	0.6339	877	-0.3919	-0.4857	1377	-0.25	0.5303	1877	-0.5383	-1.3953
378	-0.7761	0.0741	878	0.4783	-0.7561	1378	-0.8872	0.0904	1878	0.399	0.2903
379	-1.1903	-0.3727	879	-0.8041	-0.0645	1379	0.1095	-0.6144	1879	0.2723	0.6389
380	-0.9756	0.4563	880	-1.2097	-0.5419	1380	0.1946	-0.3511	1880	0.0775	-1.3992
381	0.0111	0.4458	881	0	0	1381	-0.0558	0.1274	1881	-0.6553	0.2286
382	0.8594	-0.5478	882	-0.7224	-1.061	1382	0.7378	1.0306	1882	-0.7675	0.0927
383	-0.564	0.4328	883	0.0986	-0.2501	1383	0.1524	0.7855	1883	0.2387	-0.1194
384	-0.3216	0.5171	884	-0.6047	1.2378	1384	-0.7686	-0.1897	1884	0.5741	-0.1968
385	1.25	0	885	-0.3547	-0.028	1385	-1.0303	-0.0732	1885	-0.2693	-0.8265
386	-0.3216	-0.5171	886	0.4239	-0.645	1386	-0.9171	0.8333	1886	-1.3383	0.3229
387	-0.564	-0.4328	887	0.3278	-0.6477	1387	-0.3681	1.1834	1887	-1.2295	-0.1181
388	0.8594	0.5478	888	-0.3022	-0.2338	1388	-0.1581	0.2614	1888	-0.4267	0.1254
389	0.0111	-0.4458	889	0.4053	1.0089	1389	-0.6118	-0.6114	1889	-0.5303	0.3536
390	-0.9756	-0.4563	890	1.3666	0.6059	1390	-0.1488	0.3559	1890	-0.3639	-0.3556
391	-1.1903	0.3727	891	0.1337	-0.0563	1391	1.1808	0.7177	1891	0.3827	-0.2084
392	-0.7761	-0.0741	892	0.882	-0.3037	1392	0.3623	-1.1271	1892	0.3752	-0.6378
393	0.1036	-0.6339	893	0.4167	-0.2635	1393	0.25	-0.8839	1893	0.4426	0.7547
394	0.2871	-1.2165	894	-0.7497	-0.0026	1394	1.396	-0.5758	1894	0.4059	0.7148
395	0.4219	-0.6784	895	0.8389	-1.3511	1395	0.1183	-1.1766	1895	-0.0767	-0.7739
396	0.8836	-0.4284	896	-0.0407	-1.4127	1396	-1.0588	0.6119	1896	0.2352	0.6192
397	0.5269	0.2276	897	0.75	0.25	1397	-1.5214	-0.1543	1897	0.1982	0.375
398	-0.6312	0.5158	898	1.3445	0.4739	1398	-0.3341	-0.3884	1898	-0.142	-0.7982
399	-0.3382	-0.9638	899	-0.8199	0.3431	1399	0.9788	1.7396	1899	0.7575	0.2273
400	0.3459	0.1333	900	-0.0429	0.0252	1400	-0.6621	-0.1632	1900	0.8086	0.9322
401	0.25	1.25	901	-0.5296	-0.3943	1401	-0.7803	-0.9268	1901	-0.097	-0.1385
402	1.0998	0.4827	902	-0.1959	-0.2655	1402	-0.8951	0.2553	1902	0.3477	-0.5561
403	0.4623	-0.2948	903	0.7708	-0.1596	1403	-0.9663	0.1538	1903	0.8342	0.5761

Table L.14—Complete packet (continued)

Sample	I	Q	Sample	I	Q	Sample	I	Q	Sample	I	Q
404	0.0015	-1.1597	904	-1.1196	0.2988	1404	0.9929	0.0152	1904	0.421	0.5152
405	1.1802	-0.4189	905	0.4786	0.2286	1405	0.5864	-0.1226	1905	0	0.1768
406	-0.4653	0.3832	906	1.8203	-0.2119	1406	0.0592	0.814	1906	-0.0727	0.2687
407	-0.6222	0.3373	907	0.0559	0.1768	1407	-0.4049	-0.4701	1907	0.7228	0.96
408	0.8113	-0.6423	908	-0.7192	0.4991	1408	-0.8584	-1.1959	1908	1.0263	1.2571
409	-0.6036	-1.1339	909	-0.6297	-0.1409	1409	0.8107	0.5303	1909	-0.2117	-0.4154
410	-0.5391	-0.207	910	0.2035	-0.9139	1410	0.5755	-0.5129	1910	-0.7483	-0.1364
411	-0.3165	-1.0258	911	-0.3151	0.0227	1411	-0.213	-0.0564	1911	0.1785	0.1946
412	-0.5326	-0.3518	912	-1.3792	0.8238	1412	0.6503	0.7214	1912	0.7065	-0.5663
413	0.2817	0.9077	913	-0.25	0.25	1413	1.4093	-0.3345	1913	-0.4053	0.4786
414	-0.5541	-0.4205	914	0.6563	0.5325	1414	0.7772	0.1274	1914	-1.661	-0.0392
415	0.147	-0.178	915	-0.3756	0.2564	1415	-0.0901	-0.2903	1915	-0.4411	-0.4487
416	0.5069	0.5395	916	-0.6222	-0.3347	1416	0.6632	0.3901	1916	1.1159	0.2276
417	-0.75	0	917	0.3547	0.028	1417	-0.0303	0.9268	1917	0.5193	-0.6912
418	0.5069	-0.5395	918	-0.1308	0.2017	1418	-0.2958	-0.4719	1918	0.4769	-0.3546
419	0.147	0.178	919	-0.7871	1.1608	1419	0.6884	0.2991	1919	0.6412	0.4537
420	-0.5541	0.4205	920	-0.7915	0.6192	1420	0.2517	0.2667	1920	-0.8383	-0.039
421	0.2817	-0.9077	921	-0.6553	-0.7589	1421	0.9654	-0.8028	1921	-0.1768	0.7071
422	-0.5326	0.3518	922	-0.3077	0.685	1422	0.5076	0.3542	1922	0.0188	0.0162
423	-0.3165	1.0258	923	0.1051	0.4707	1423	-0.1534	0.8546	1923	-0.0149	0.0996
424	-0.5391	0.207	924	0.765	-1.2526	1424	0.9041	-0.5678	1924	0.0536	0.6254
425	-0.6036	1.1339	925	-0.5632	-0.5901	1425	-0.1036	-0.1768	1925	1.2606	0.0549
426	0.8113	0.6423	926	-0.9437	-0.1152	1426	-0.5071	1.4348	1926	0.5406	-0.1999
427	-0.6222	-0.3373	927	0.4703	-0.3946	1427	-0.2218	0.3474	1927	-0.6483	0.1982
428	-0.4653	-0.3832	928	-0.1704	-0.2313	1428	-0.4394	-0.5773	1928	0.4289	-1.1884
429	1.1802	0.4189	929	0.5	0.5	1429	0.1678	-0.3457	1929	-0.0214	-0.8018
430	0.0015	1.1597	930	0.8652	1.0323	1430	-0.0687	-0.7158	1930	0.2803	0.4548
431	0.4623	0.2948	931	-0.1102	0.8577	1431	0.1659	-0.3205	1931	0.7002	-0.3675
432	1.0998	-0.4827	932	0.7064	1.19	1432	0.4969	-0.1672	1932	-1.0376	-0.2012
433	0.25	-1.25	933	0.5296	0.3943	1433	-0.2803	0.0732	1933	-0.8039	-0.074
434	0.3459	-0.1333	934	0.1419	-0.6515	1434	-0.4692	0.361	1934	-0.3884	0.1453
435	-0.3382	0.9638	935	0.1885	0.5606	1435	-0.5611	-0.1364	1935	-0.6539	0.3117
436	-0.6312	-0.5158	936	-0.1471	0.7344	1436	-0.4332	-0.3624	1936	-1.1651	-1.1555
437	0.5269	-0.2276	937	-0.2286	-0.4786	1437	0.4743	-0.5845	1937	-1.7678	-0.8839
438	0.8836	0.4284	938	-0.1944	-0.6425	1438	0.4699	-0.1637	1938	-0.7176	0.0897
439	0.4219	0.6784	939	-0.0877	-0.7983	1439	-0.4154	-0.188	1939	0.1292	-0.3738
440	0.2871	1.2165	940	-0.95	-1.0612	1440	-0.1374	-0.3935	1940	0.8451	-0.1536

Table L.14—Complete packet (continued)

Sample	I	Q	Sample	I	Q	Sample	I	Q	Sample	I	Q
441	0.1036	0.6339	941	-0.2238	-0.0056	1441	0.0732	0.7071	1941	-0.0497	0.0946
442	-0.7761	0.0741	942	0.4224	0.9778	1442	-0.1505	0.1106	1942	-0.8163	-0.3697
443	-1.1903	-0.3727	943	-0.494	-0.1912	1443	0.7487	-0.2539	1943	0.712	-0.1527
444	-0.9756	0.4563	944	0.5364	-0.5984	1444	0.5702	-0.3195	1944	-0.2692	0.0432
445	0.0111	0.4458	945	0	0	1445	0.2407	-0.4889	1945	-0.4786	-0.1982
446	0.8594	-0.5478	946	-0.7224	-1.061	1446	1.4049	0.235	1946	0.9743	-0.3294
447	-0.564	0.4328	947	0.0986	-0.2501	1447	0.267	0.8823	1947	0.9417	-0.7351
448	-0.3216	0.5171	948	-0.6047	1.2378	1448	-0.1098	0.5457	1948	0.5535	-0.3754
449	1.25	0	949	-0.3547	-0.028	1449	0	0.4571	1949	-1.1141	-0.4582
450	-0.3216	-0.5171	950	0.4239	-0.645	1450	-1.0648	0.1166	1950	-0.3284	-0.1895
451	-0.564	-0.4328	951	0.3278	-0.6477	1451	-0.1968	0.4275	1951	0.7145	1.911
452	0.8594	0.5478	952	-0.3022	-0.2338	1452	-0.2262	0.5005	1952	-1.0893	0.7769
453	0.0111	-0.4458	953	0.4053	1.0089	1453	-0.1371	-0.9889	1953	0.1768	-0.3536
454	-0.9756	-0.4563	954	1.3666	0.6059	1454	0.9962	-0.8207	1954	1.2181	0.7631
455	-1.1903	0.3727	955	0.1337	-0.0563	1455	0.7019	0.0296	1955	-0.4021	-0.3447
456	-0.7761	-0.0741	956	0.882	-0.3037	1456	-0.2743	0.2598	1956	-0.923	0.2865
457	0.1036	-0.6339	957	0.4167	-0.2635	1457	-0.7803	0.3536	1957	-0.2606	0.6522
458	0.2871	-1.2165	958	-0.7497	-0.0026	1458	0.2517	-0.5182	1958	0.692	-0.9556
459	0.4219	-0.6784	959	0.8389	-1.3511	1459	-0.5378	-0.1761	1959	0.3486	-0.0292
460	0.8836	-0.4284	960	-0.0407	-1.4127	1460	-1.694	-0.1293	1960	0.3173	0.7422
461	0.5269	0.2276	961	-0.8839	0.3536	1461	-0.4844	-0.6802	1961	0.7286	0.4482
462	-0.6312	0.5158	962	-0.0336	0.8687	1462	-0.9842	0.2458	1962	-0.3733	-0.2533
463	-0.3382	-0.9638	963	-0.7799	0.1728	1463	-1.1416	-0.1229	1963	-0.4999	-0.1482
464	0.3459	0.1333	964	0.1891	-0.6159	1464	-0.0986	0.3233	1964	0.0756	0.04
465	0.25	1.25	965	0.6734	-0.4006	1465	-0.25	0.6036	1965	0.0968	-1.1331
466	1.0998	0.4827	966	0.2461	0.05	1466	-0.5928	-1.5937	1966	0.9873	0.4546
467	0.4623	-0.2948	967	1.184	0.4273	1467	-0.1564	-0.3116	1967	0.7369	1.2041
468	0.0015	-1.1597	968	0.4654	0.1181	1468	0.4498	1.6195	1968	-0.7251	0.0654
469	1.1802	-0.4189	969	-1.5089	-0.125	1469	-0.0273	0.4731	1969	0.3536	0.5303
470	-0.4653	0.3832	970	-0.2443	-0.146	1470	0.5568	-0.6178	1970	1.1877	-0.4863
471	-0.6222	0.3373	971	0.7714	-0.6208	1471	0.3324	-0.8678	1971	-0.005	-0.7952
472	0.8113	-0.6423	972	-0.6118	-0.675	1472	-0.7073	0.476	1972	-0.224	0.1656
473	-0.6036	-1.1339	973	-0.8753	-0.5169	1473	0.4268	0	1973	-0.9503	0.6125
474	-0.5391	-0.207	974	-0.5449	-0.4082	1474	-0.4977	-0.9329	1974	-0.7091	0.6012
475	-0.3165	-1.0258	975	0.4193	0.2374	1475	-0.6901	1.2402	1975	0.2949	-0.6021
476	-0.5326	-0.3518	976	1.6786	0.8281	1476	0.7908	0.7534	1976	-0.8776	0.0204
477	0.2817	0.9077	977	1.4142	0.8839	1477	0.32	-0.2183	1977	-0.2286	0.5518

Table L.14—Complete packet (continued)

Sample	I	Q	Sample	I	Q	Sample	I	Q	Sample	I	Q
478	-0.5541	-0.4205	978	0.5174	0.1582	1478	1.0434	0.7155	1978	0.8257	-0.2548
479	0.147	-0.178	979	0.9204	-0.7007	1479	0.4069	-0.0239	1979	0.5651	-0.1633
480	0.5069	0.5395	980	0.9337	-0.233	1480	-1.1428	0.3316	1980	1.2426	-0.3872
481	0.75	0.75	981	-1.1459	0.74	1481	0	0.4571	1981	0.407	0.2511
482	0.7478	0.8804	982	0.0935	0.3738	1482	0.7672	-0.3292	1982	-0.5633	0.5135
483	-1.8473	0.0292	983	1.4272	-0.6626	1483	0.1381	-0.0534	1983	-0.0903	-0.0125
484	-1.0324	0.3448	984	-0.8333	-0.0067	1484	-0.4874	-0.8099	1984	-0.0342	0.6959
485	0.1609	0.3108	985	-0.1553	1.0821	1485	-0.2164	-0.7183	1985	-0.1768	0.7071
486	0.1388	-0.4451	986	-0.1296	-0.1823	1486	-0.243	-0.2394	1986	0.0188	0.0162
487	-0.106	-1.0522	987	-0.6472	-1.0287	1487	-0.1813	-0.2886	1987	-0.0149	0.0996
488	-0.8661	-0.2156	988	0.8176	-0.0763	1488	-0.3657	0.4548	1988	0.0536	0.6254
489	0.125	0.8321	989	0.0201	-0.0676	1489	-1.1339	-0.3536	1989	1.2606	0.0549
490	0.1346	0.4	990	0.0225	0.0677	1490	0.3331	-0.3613	1990	0.5406	-0.1999
491	-0.5951	0.2595	991	-0.0539	0.6489	1491	0.9791	0.397	1991	-0.6483	0.1982
492	-0.1195	0.4088	992	-0.2031	0.0917	1492	0.7792	-0.7507	1992	0.4289	-1.1884
493	-0.5779	0.5428	993	0.5303	-0.3536	1493	0.6308	-0.0269	1993	-0.0214	-0.8018
494	-0.255	0.5079	994	-0.4082	-0.3206	1494	-0.9103	1.0976	1994	0.2803	0.4548
495	0.9598	0.3728	995	0.4178	0.0615	1495	-0.0323	0.0574	1995	0.7002	-0.3675
496	-0.313	1.1997	996	0.3409	0.0797	1496	0.4147	-0.264	1996	-1.0376	-0.2012
497	-1	0	997	-0.8805	-0.8065	1497	0.25	0.6036	1997	-0.8039	-0.074
498	0.6711	-1.687	998	-0.2006	-0.1009	1498	1.3681	1.0939	1998	-0.3884	0.1453
499	-0.2918	-0.4937	999	-0.0355	0.8364	1499	-0.2849	0.1445	1999	-0.6539	0.3117
500	-1.2035	-0.2092	1000	0.3413	0.0992	1500	-0.5966	-0.4497	2000	-1.1651	-1.1555

Insert after new Annex L the following new annex (Annex M):

Annex M

(informative)

Example of encoding a packet for MR-OFDM PHY when PIB attribute *phyOFDMInterleaving* is one

M.1 Introduction

The purpose of this annex is to show an example of encoding a packet for the MR-OFDM PHY, as described in 18.2. This example covers all the encoding details defined by this standard. The encoding illustration is outlined in L.1.

In the description of time domain waveforms, a complex baseband signal at 666.666 ksample/s is used. This example uses the 400 kb/s data rate (QPSK 1/2-rate modulation), which corresponds to OFDM Option 2 and MCS level 3, and a message of 72 octets. The OFDM Header uses the 50 kb/s data rate (BPSK 1/2-rate coded with 4x frequency repetition), which corresponds to MCS level 0. This example also sets the PIB attribute value of *phyOFDMInterleaving* to one.

M.2 The message

The message being encoded is given in L.2.

M.3 Generation of the OFDM header

M.3.1 HCS and PAD bits insertion

In this example, the payload data has a size of 76 octets, and it will be encoded using QPSK modulation, 1/2-rate coding (Rate field value = 3). The scrambler index will be the first one (Scrambler ID = 0).

The corresponding OFDM header, including the HCS, is represented in Table M.1.

In this configuration, 12 PAD bit are necessary. The size of the header will fill up exactly eight OFDM symbols.

M.3.2 Convolutional encoding

After convolutional encoding of the OFDM header, the size is now doubled and the corresponding bits are represented in Table M.2. No puncturing is applied in this configuration.

Table M.1—OFDM Header

Field Name	Bit #	Bit Value		Field Name	Bit #	Bit Value	
Rate	1	0		HCS	23	1	
	2	0			24	1	
	3	0			25	1	
	4	1			26	1	
	5	1			27	1	
RFU	6	0			28	1	
	7	0			29	0	
Length	8	0			30	1	
	9	0			Tail	31	0
	10	0				32	0
	11	1		33		0	
	12	0		34		0	
	13	0		35		0	
	14	1		36		0	
	15	1		Pad		37	0
	16	0				38	0
	17	0			39	0	
RFU	18	0			40	0	
	19	0			41	0	
Scrambler	20	0			42	0	
	21	0			43	0	
RFU	22	0			44	0	
			45		0		
			46		0		
			47	0			
			48	0			

Table M.2—OFDM Header after convolutional encoding

Bit #	Bit Value	Bit #	Bit Value	Bit #	Bit Value	Bit #	Bit Value
1	0	25	1	49	0	73	0
2	0	26	1	50	1	74	0
3	0	27	0	51	1	75	0
4	0	28	0	52	0	76	0
5	0	29	1	53	1	77	0
6	0	30	0	54	0	78	0
7	1	31	0	55	0	79	0
8	1	32	0	56	0	80	0
9	1	33	1	57	0	81	0
10	0	34	1	58	0	82	0
11	1	35	1	59	1	83	0
12	0	36	1	60	0	84	0
13	0	37	1	61	1	85	0
14	0	38	0	62	1	86	0
15	1	39	0	63	1	87	0
16	1	40	1	64	0	88	0
17	1	41	1	65	1	89	0
18	0	42	1	66	0	90	0
19	0	43	0	67	1	91	0
20	1	44	0	68	1	92	0
21	0	45	1	69	1	93	0
22	0	46	1	70	0	94	0
23	0	47	1	71	1	95	0
24	1	48	0	72	1	96	0

M.3.3 Interleaving

A two-step interleaver is applied to the data, as defined in 18.2.3.5. In this case, N_{cbps} is defined as 48 and N_{row} is 3. The corresponding bits are represented in Table M.3.

Table M.3—OFDM Header after interleaving

Bit #	Bit Value	Bit #	Bit Value	Bit #	Bit Value	Bit #	Bit Value
1	0	25	1	49	0	73	0
2	0	26	1	50	0	74	0
3	1	27	0	51	0	75	0
4	0	28	1	52	0	76	0
5	0	29	0	53	1	77	0
6	1	30	1	54	0	78	0
7	0	31	0	55	1	79	0
8	0	32	1	56	0	80	0
9	1	33	0	57	0	81	1
10	0	34	0	58	0	82	0
11	0	35	1	59	0	83	0
12	1	36	0	60	0	84	0
13	1	37	1	61	0	85	1
14	1	38	0	62	0	86	0
15	0	39	0	63	0	87	1
16	1	40	1	64	0	88	1
17	0	41	0	65	1	89	0
18	0	42	0	66	1	90	0
19	1	43	1	67	0	91	0
20	1	44	1	68	1	92	0
21	0	45	0	69	1	93	0
22	1	46	1	70	1	94	0
23	1	47	1	71	1	95	0
24	0	48	0	72	1	96	0

M.3.4 Bit mapping

The 96 bits are split into eight OFDM symbols. The bit mapping for the OFDM header in this example is BPSK. Therefore, Q is always zero. The I value is mapped as defined in Table M.4.

Table M.4—Bit mapping for the OFDM Header

	Symbol 1		Symbol 2		Symbol 3		Symbol 4		Symbol 5		Symbol 6		Symbol 7		Symbol 8	
	I	Q	I	Q	I	Q	I	Q	I	Q	I	Q	I	Q	I	Q
1	-1	0	1	0	1	0	1	0	-1	0	-1	0	-1	0	1	0
2	-1	0	1	0	1	0	-1	0	-1	0	-1	0	-1	0	-1	0
3	1	0	-1	0	-1	0	-1	0	-1	0	-1	0	-1	0	1	0
4	-1	0	1	0	1	0	1	0	-1	0	-1	0	-1	0	1	0
5	-1	0	-1	0	-1	0	-1	0	1	0	1	0	-1	0	-1	0
6	1	0	-1	0	1	0	-1	0	-1	0	1	0	-1	0	-1	0
7	-1	0	1	0	-1	0	1	0	1	0	-1	0	-1	0	-1	0
8	-1	0	1	0	1	0	1	0	-1	0	1	0	-1	0	-1	0
9	1	0	-1	0	-1	0	-1	0	-1	0	1	0	1	0	-1	0
10	-1	0	1	0	-1	0	1	0	-1	0	1	0	-1	0	-1	0
11	-1	0	1	0	1	0	1	0	-1	0	1	0	-1	0	-1	0
12	1	0	-1	0	-1	0	-1	0	-1	0	1	0	-1	0	-1	0

M.3.5 Frequency spreading

In this example, a frequency spreading of four is applied to the OFDM header. The original 12 bits in each symbol (Bin # 25 through 36 in Table M.5) are duplicated within the same symbol. The resulting symbols have 48 data bits each. The duplicated bits have a phase rotation, as defined in 18.2.3.6.

Table M.5—OFDM Header in the frequency domain

	Symbol 1		Symbol 2		Symbol 3		Symbol 4		Symbol 5		Symbol 6		Symbol 7		Symbol 8	
	I	Q	I	Q	I	Q	I	Q	I	Q	I	Q	I	Q	I	Q
1	0	-1	0	1	0	1	0	1	0	-1	0	-1	0	-1	0	1
2	0	1	0	-1	0	-1	0	1	0	1	0	1	0	1	0	1
3	0	1	0	-1	0	-1	0	-1	0	-1	0	-1	0	-1	0	1
4	0	1	0	-1	0	-1	0	-1	0	1	0	1	0	1	0	-1
5	0	-1	0	-1	0	-1	0	-1	0	1	0	1	0	-1	0	-1
6	0	-1	0	1	0	-1	0	1	0	1	0	-1	0	1	0	1

Table M.5—OFDM Header in the frequency domain (continued)

	Symbol 1		Symbol 2		Symbol 3		Symbol 4		Symbol 5		Symbol 6		Symbol 7		Symbol 8	
	I	Q	I	Q	I	Q	I	Q	I	Q	I	Q	I	Q	I	Q
7	0	-1	0	1	0	-1	0	1	0	1	0	-1	0	-1	0	-1
8	0	1	0	-1	0	-1	0	-1	0	1	0	-1	0	1	0	1
9	0	1	0	-1	0	-1	0	-1	0	-1	0	1	0	1	0	-1
10	0	1	0	-1	0	1	0	-1	0	1	0	-1	0	1	0	1
11	0	-1	0	1	0	1	0	1	0	-1	0	1	0	-1	0	-1
12	0	-1	0	1	0	1	0	1	0	1	0	-1	0	1	0	1
13	1	0	-1	0	-1	0	-1	0	1	0	1	0	1	0	-1	0
14	0	-1	0	1	0	1	0	-1	0	-1	0	-1	0	-1	0	-1
15	1	0	-1	0	-1	0	-1	0	-1	0	-1	0	-1	0	1	0
16	0	1	0	-1	0	-1	0	-1	0	1	0	1	0	1	0	-1
17	1	0	1	0	1	0	1	0	-1	0	-1	0	1	0	1	0
18	0	1	0	-1	0	1	0	-1	0	-1	0	1	0	-1	0	-1
19	-1	0	1	0	-1	0	1	0	1	0	-1	0	-1	0	-1	0
20	0	1	0	-1	0	-1	0	-1	0	1	0	-1	0	1	0	1
21	-1	0	1	0	1	0	1	0	1	0	-1	0	-1	0	1	0
22	0	-1	0	1	0	-1	0	1	0	-1	0	1	0	-1	0	-1
23	-1	0	1	0	1	0	1	0	-1	0	1	0	-1	0	-1	0
24	0	-1	0	1	0	1	0	1	0	1	0	-1	0	1	0	1
25	-1	0	1	0	1	0	1	0	-1	0	-1	0	-1	0	1	0
26	-1	0	1	0	1	0	-1	0	-1	0	-1	0	-1	0	-1	0
27	1	0	-1	0	-1	0	-1	0	-1	0	-1	0	-1	0	1	0
28	-1	0	1	0	1	0	1	0	-1	0	-1	0	-1	0	1	0
29	-1	0	-1	0	-1	0	-1	0	1	0	1	0	-1	0	-1	0
30	1	0	-1	0	1	0	-1	0	-1	0	1	0	-1	0	-1	0
31	-1	0	1	0	-1	0	1	0	1	0	-1	0	-1	0	-1	0
32	-1	0	1	0	1	0	1	0	-1	0	1	0	-1	0	-1	0
33	1	0	-1	0	-1	0	-1	0	-1	0	1	0	1	0	-1	0
34	-1	0	1	0	-1	0	1	0	-1	0	1	0	-1	0	-1	0
35	-1	0	1	0	1	0	1	0	-1	0	1	0	-1	0	-1	0
36	1	0	-1	0	-1	0	-1	0	-1	0	1	0	-1	0	-1	0
37	-1	0	1	0	1	0	1	0	-1	0	-1	0	-1	0	1	0
38	0	-1	0	1	0	1	0	-1	0	-1	0	-1	0	-1	0	-1

Table M.5—OFDM Header in the frequency domain (continued)

	Symbol 1		Symbol 2		Symbol 3		Symbol 4		Symbol 5		Symbol 6		Symbol 7		Symbol 8	
	I	Q	I	Q	I	Q	I	Q	I	Q	I	Q	I	Q	I	Q
39	-1	0	1	0	1	0	1	0	1	0	1	0	1	0	-1	0
40	0	1	0	-1	0	-1	0	-1	0	1	0	1	0	1	0	-1
41	-1	0	-1	0	-1	0	-1	0	1	0	1	0	-1	0	-1	0
42	0	1	0	-1	0	1	0	-1	0	-1	0	1	0	-1	0	-1
43	1	0	-1	0	1	0	-1	0	-1	0	1	0	1	0	1	0
44	0	1	0	-1	0	-1	0	-1	0	1	0	-1	0	1	0	1
45	1	0	-1	0	-1	0	-1	0	-1	0	1	0	1	0	-1	0
46	0	-1	0	1	0	-1	0	1	0	-1	0	1	0	-1	0	-1
47	1	0	-1	0	-1	0	-1	0	1	0	-1	0	1	0	1	0
48	0	-1	0	1	0	1	0	1	0	1	0	-1	0	1	0	1

M.4 Generation of the data symbols

M.4.1 PAD insertion and data scrambling

The original 76 octets of data, as defined in Table L.1, are concatenated with six zero tail bits and 10 pad bits (as calculated by the formulas in 18.2.3.10). The six tail bits are forced to zero after scrambling. The resulting 624 bits are represented in Table M.6 (first and last 48 bits only).

Table M.6—First and last 48 bits after pad insertion and scrambling

Bit #	Bit Value	Bit #	Bit Value	Bit #	Bit Value	Bit #	Bit Value
1	1	25	0	577	0	601	1
2	0	26	0	578	0	602	0
3	0	27	0	579	1	603	0
4	0	28	0	580	0	604	0
5	0	29	0	581	0	605	0
6	1	30	0	582	1	606	0
7	0	31	0	583	1	607	0
8	0	32	1	584	0	608	0
9	0	33	0	585	0	609	0
10	1	34	0	586	1	610	0
11	0	35	0	587	1	611	0
12	1	36	0	588	0	612	0

Table M.6—First and last 48 bits after pad insertion and scrambling (*continued*)

Bit #	Bit Value	Bit #	Bit Value	Bit #	Bit Value	Bit #	Bit Value
13	1	37	0	589	1	613	0
14	1	38	0	590	1	614	0
15	0	39	1	591	0	615	0
16	0	40	1	592	0	616	0
17	1	41	0	593	1	617	0
18	0	42	1	594	0	618	0
19	0	43	1	595	1	619	0
20	0	44	0	596	1	620	1
21	1	45	1	597	1	621	1
22	1	46	0	598	1	622	0
23	0	47	0	599	0	623	1
24	1	48	0	600	0	624	1

M.4.2 Convolutional encoding and puncturing

After convolutional encoding of the payload, the size is now doubled and the corresponding bits are represented in Table M.7. No puncturing is applied in this configuration.

Table M.7—First and last 48 bits after convolutional encoding

Bit #	Bit Value	Bit #	Bit Value	Bit #	Bit Value	Bit #	Bit Value
1	1	25	0	1201	0	1225	0
2	1	26	1	1202	1	1226	0
3	0	27	0	1203	0	1227	0
4	1	28	1	1204	0	1228	0
5	1	29	1	1205	1	1229	0
6	1	30	1	1206	0	1230	0
7	1	31	1	1207	0	1231	0
8	1	32	1	1208	0	1232	0
9	0	33	1	1209	0	1233	0
10	0	34	0	1210	0	1234	0
11	0	35	0	1211	1	1235	0
12	1	36	0	1212	0	1236	0
13	1	37	1	1213	1	1237	0

Table M.7—First and last 48 bits after convolutional encoding (continued)

Bit #	Bit Value	Bit #	Bit Value	Bit #	Bit Value	Bit #	Bit Value
14	0	38	0	1214	1	1238	0
15	1	39	0	1215	0	1239	1
16	1	40	0	1216	0	1240	1
17	1	41	1	1217	0	1241	1
18	1	42	1	1218	0	1242	0
19	1	43	0	1219	0	1243	1
20	1	44	0	1220	0	1244	0
21	1	45	0	1221	0	1245	1
22	1	46	1	1222	0	1246	1
23	1	47	1	1223	0	1247	0
24	1	48	1	1224	0	1248	1

M.4.3 Interleaving

A two-step interleaver is applied to the data, as defined in 18.2.3.5. In this case, N_{cbps} is defined as 96 and N_{row} is 12. The resulting data (first and last 48 bits only) is represented in Table M.8.

Table M.8—First and last 48 bits after interleaving

Bit #	Bit Value	Bit #	Bit Value	Bit #	Bit Value	Bit #	Bit Value
1	1	25	1	1201	0	1225	0
2	1	26	1	1202	0	1226	0
3	0	27	1	1203	0	1227	1
4	1	28	0	1204	0	1228	0
5	1	29	1	1205	0	1229	0
6	0	30	1	1206	0	1230	0
7	1	31	1	1207	0	1231	0
8	0	32	0	1208	1	1232	1
9	1	33	1	1209	0	1233	1
10	0	34	1	1210	0	1234	1
11	1	35	1	1211	1	1235	1
12	0	36	1	1212	0	1236	1

Table M.8—First and last 48 bits after interleaving (continued)

Bit #	Bit Value	Bit #	Bit Value	Bit #	Bit Value	Bit #	Bit Value
13	0	37	1	1213	0	1237	1
14	0	38	0	1214	0	1238	0
15	0	39	1	1215	0	1239	0
16	1	40	1	1216	0	1240	0
17	0	41	1	1217	1	1241	1
18	1	42	1	1218	0	1242	1
19	0	43	1	1219	1	1243	1
20	0	44	1	1220	1	1244	0
21	0	45	0	1221	0	1245	0
22	1	46	1	1222	0	1246	0
23	1	47	1	1223	0	1247	0
24	0	48	0	1224	1	1248	1

M.4.4 Bit mapping

The bit mapping for the OFDM header in this example is QPSK (two data bits per vector). The I and Q vectors are mapped as defined in Figure 133. The resulting data are represented in Table M.9 (first two and last two symbols).

Table M.9—Bit mapping for the OFDM payload

Vector #	I	Q	Vector #	I	Q	Vector #	I	Q	Vector #	I	Q
1	0.707	0.707	49	0.707	-0.707	529	-0.707	-0.707	577	-0.707	0.707
2	-0.707	0.707	50	-0.707	0.707	530	-0.707	0.707	578	-0.707	-0.707
3	0.707	-0.707	51	-0.707	-0.707	531	-0.707	0.707	579	-0.707	0.707
4	0.707	-0.707	52	0.707	-0.707	532	-0.707	-0.707	580	-0.707	-0.707
5	0.707	-0.707	53	0.707	-0.707	533	-0.707	0.707	581	0.707	-0.707
6	0.707	-0.707	54	-0.707	0.707	534	-0.707	0.707	582	-0.707	0.707
7	-0.707	-0.707	55	-0.707	-0.707	535	0.707	0.707	583	0.707	0.707
8	-0.707	0.707	56	0.707	-0.707	536	-0.707	0.707	584	-0.707	-0.707

Table M.9—Bit mapping for the OFDM payload (*continued*)

Vector #	I	Q	Vector #	I	Q	Vector #	I	Q	Vector #	I	Q
9	-0.707	0.707	57	0.707	-0.707	537	-0.707	-0.707	585	-0.707	-0.707
10	-0.707	-0.707	58	0.707	0.707	538	-0.707	-0.707	586	-0.707	0.707
11	-0.707	0.707	59	0.707	-0.707	539	0.707	0.707	587	-0.707	-0.707
12	0.707	-0.707	60	-0.707	-0.707	540	-0.707	0.707	588	-0.707	0.707
13	0.707	0.707	61	-0.707	-0.707	541	0.707	0.707	589	-0.707	-0.707
14	0.707	-0.707	62	0.707	-0.707	542	-0.707	-0.707	590	0.707	-0.707
15	0.707	0.707	63	0.707	-0.707	543	-0.707	0.707	591	-0.707	-0.707
16	0.707	-0.707	64	-0.707	-0.707	544	-0.707	0.707	592	-0.707	0.707
17	0.707	0.707	65	-0.707	0.707	545	-0.707	0.707	593	0.707	0.707
18	0.707	0.707	66	-0.707	-0.707	546	-0.707	-0.707	594	-0.707	-0.707
19	0.707	-0.707	67	-0.707	0.707	547	-0.707	0.707	595	0.707	-0.707
20	0.707	0.707	68	0.707	0.707	548	0.707	0.707	596	-0.707	0.707
21	0.707	0.707	69	-0.707	0.707	549	0.707	0.707	597	-0.707	0.707
22	0.707	0.707	70	0.707	0.707	550	0.707	-0.707	598	-0.707	0.707
23	-0.707	0.707	71	0.707	0.707	551	0.707	-0.707	599	-0.707	-0.707
24	0.707	-0.707	72	0.707	0.707	552	-0.707	0.707	600	-0.707	-0.707
25	0.707	0.707	73	0.707	-0.707	553	-0.707	-0.707	601	-0.707	-0.707
26	0.707	-0.707	74	-0.707	-0.707	554	0.707	0.707	602	-0.707	-0.707
27	0.707	0.707	75	0.707	-0.707	555	0.707	0.707	603	-0.707	-0.707
28	0.707	-0.707	76	0.707	0.707	556	0.707	0.707	604	-0.707	0.707
29	0.707	0.707	77	-0.707	-0.707	557	-0.707	-0.707	605	-0.707	-0.707
30	0.707	-0.707	78	0.707	0.707	558	-0.707	0.707	606	0.707	-0.707
31	0.707	0.707	79	0.707	0.707	559	-0.707	0.707	607	-0.707	-0.707
32	-0.707	0.707	80	-0.707	0.707	560	0.707	0.707	608	-0.707	-0.707
33	-0.707	0.707	81	0.707	-0.707	561	-0.707	-0.707	609	0.707	-0.707
34	0.707	-0.707	82	-0.707	0.707	562	-0.707	-0.707	610	0.707	0.707
35	0.707	0.707	83	0.707	-0.707	563	-0.707	-0.707	611	-0.707	-0.707
36	0.707	-0.707	84	0.707	0.707	564	-0.707	-0.707	612	-0.707	0.707

Table M.9—Bit mapping for the OFDM payload (*continued*)

Vector #	I	Q	Vector #	I	Q	Vector #	I	Q	Vector #	I	Q
37	-0.707	0.707	85	-0.707	0.707	565	0.707	0.707	613	-0.707	-0.707
38	-0.707	0.707	86	0.707	0.707	566	0.707	0.707	614	0.707	-0.707
39	-0.707	0.707	87	-0.707	0.707	567	-0.707	0.707	615	-0.707	-0.707
40	-0.707	0.707	88	-0.707	0.707	568	-0.707	-0.707	616	-0.707	0.707
41	-0.707	0.707	89	-0.707	0.707	569	0.707	0.707	617	0.707	0.707
42	-0.707	0.707	90	0.707	0.707	570	-0.707	-0.707	618	0.707	0.707
43	0.707	-0.707	91	-0.707	-0.707	571	-0.707	-0.707	619	0.707	-0.707
44	0.707	0.707	92	-0.707	0.707	572	0.707	0.707	620	-0.707	-0.707
45	0.707	0.707	93	-0.707	0.707	573	0.707	-0.707	621	0.707	0.707
46	-0.707	0.707	94	0.707	0.707	574	0.707	-0.707	622	0.707	-0.707
47	0.707	-0.707	95	-0.707	0.707	575	0.707	0.707	623	-0.707	-0.707
48	0.707	-0.707	96	-0.707	-0.707	576	0.707	-0.707	624	-0.707	0.707

M.4.5 Frequency spreading

In this example, no frequency spreading is applied to the OFDM payload. The vectors from Table M.9 are mapped directly into the frequency domain. Subclause M.5 illustrates the mapping in the frequency domain, taking into account the pilot tones, the DC tone, and the guard tones.

M.5 Conversion from frequency domain to time domain

M.5.1 Pilot, DC, and guard tone insertion

The following steps are applied to both the OFDM header and the OFDM payload. Before going to the next steps, Table M.5 and Table M.9 should be appended, resulting in 21 symbols of 48 bins in the frequency domain. The 48 bins are mapped in the frequency domain by inserting pilot tones, guard tones, and a DC tone, as defined in 18.2.3.7, and the first and last three symbols of the complete packet in the frequency domain are given in Table M.10.

M.5.2 Time domain OFDM header and payload

The data from Table M.10 is converted by an IFFT of size 64. Most IFFTs require a reordering of the data. Typically, the order of the frequencies within each symbol should be as follows:

0, 1, 2, ..., 31, -32, -31, ..., -1

Table M.10—Complete Packet in the frequency domain (first and last three symbols)

Subcarrier	Symbol 1	Symbol 2	Symbol 3	Symbol 19	Symbol 20	Symbol 21
-32	0	0	0	0	0	0
-31	0	0	0	0	0	0
-30	0	0	0	0	0	0
-29	0	0	0	0	0	0
-28	0	0	0	0	0	0
-27	0	0	0	0	0	0
-26	$-0 - 1i$	$0 + 1i$	$0 + 1i$	$-0.707 + 0.707i$	$-0.707 - 0.707i$	-1
-25	$0 + 1i$	$-0 - 1i$	$-0 - 1i$	$-0.707 - 0.707i$	$-0.707 + 0.707i$	$-0.707 + 0.707i$
-24	$0 + 1i$	$-0 - 1i$	$-0 - 1i$	$0.707 + 0.707i$	$-0.707 + 0.707i$	$-0.707 - 0.707i$
-23	$0 + 1i$	$-0 - 1i$	$-0 - 1i$	$0.707 - 0.707i$	$-0.707 - 0.707i$	$-0.707 + 0.707i$
-22	$-0 - 1i$	1	$-0 - 1i$	1	$-0.707 + 0.707i$	$-0.707 - 0.707i$
-21	$-0 - 1i$	$-0 - 1i$	$-0 - 1i$	$0.707 - 0.707i$	$-0.707 + 0.707i$	$0.707 - 0.707i$
-20	$0 - 1i$	$0 + 1i$	$0 - 1i$	$0.707 - 0.707i$	$0.707 + 0.707i$	$-0.707 + 0.707i$
-19	$0 + 1i$	$-0 + 1i$	$-0 - 1i$	$-0.707 - 0.707i$	$-0.707 + 0.707i$	$0.707 + 0.707i$
-18	$-0 + 1i$	$-0 - 1i$	-1	$-0.707 - 0.707i$	-1	$-0.707 - 0.707i$
-17	$0 + 1i$	$0 - 1i$	$0 - 1i$	$0.707 + 0.707i$	$-0.707 - 0.707i$	$-0.707 - 0.707i$
-16	$0 - 1i$	$-0 - 1i$	$0 + 1i$	$-0.707 - 0.707i$	$-0.707 - 0.707i$	$-0.707 + 0.707i$
-15	$-0 - 1i$	$-0 + 1i$	$-0 + 1i$	$0.707 + 0.707i$	$0.707 + 0.707i$	$-0.707 - 0.707i$
-14	-1	$0 + 1i$	$0 + 1i$	$0.707 - 0.707i$	$-0.707 + 0.707i$	$-0.707 + 0.707i$
-13	$1 - 0i$	$-1 + 0i$	$-1 + 0i$	$-0.707 - 0.707i$	$0.707 + 0.707i$	$-0.707 - 0.707i$
-12	$-0 - 1i$	$0 + 1i$	$0 + 1i$	$-0.707 + 0.707i$	$-0.707 - 0.707i$	$0.707 - 0.707i$
-11	$1 - 0i$	$-1 + 0i$	$-1 + 0i$	$-0.707 - 0.707i$	$-0.707 + 0.707i$	$-0.707 - 0.707i$
-10	$0 + 1i$	1	$-0 - 1i$	-1	$-0.707 + 0.707i$	$-0.707 + 0.707i$
-9	$1 - 0i$	$-0 - 1i$	$1 - 0i$	$0.707 + 0.707i$	$-0.707 + 0.707i$	$0.707 + 0.707i$
-8	$-0 + 1i$	$1 - 0i$	$-0 + 1i$	$-0.707 - 0.707i$	$-0.707 - 0.707i$	$-0.707 - 0.707i$
-7	$-1 + 0i$	$0 - 1i$	$-1 + 0i$	$0.707 + 0.707i$	$-0.707 + 0.707i$	$0.707 - 0.707i$
-6	$0 + 1i$	$1 - 0i$	1	$0.707 + 0.707i$	1	$-0.707 + 0.707i$
-5	$-1 - 0i$	$-0 - 1i$	$-0 - 1i$	$0.707 + 0.707i$	$0.707 + 0.707i$	$-0.707 + 0.707i$
-4	$0 - 1i$	$1 + 0i$	$1 + 0i$	$-0.707 + 0.707i$	$0.707 + 0.707i$	$-0.707 + 0.707i$
-3	$-1 + 0i$	$-0 + 1i$	$0 - 1i$	$0.707 - 0.707i$	$0.707 - 0.707i$	$-0.707 - 0.707i$
-2	-1	$1 - 0i$	$1 - 0i$	$0.707 - 0.707i$	$0.707 - 0.707i$	$-0.707 - 0.707i$
-1	$-0 - 1i$	$0 + 1i$	$0 + 1i$	$0.707 + 0.707i$	$-0.707 + 0.707i$	$-0.707 - 0.707i$

Table M.10—Complete Packet in the frequency domain (first and last three symbols)

Subcarrier	Symbol 1	Symbol 2	Symbol 3	Symbol 19	Symbol 20	Symbol 21
0	0	0	0	0	0	0
1	-1	1	1	$-0.707 + 0.707i$	$-0.707 - 0.707i$	$-0.707 - 0.707i$
2	-1	1	1	$0.707 - 0.707i$	1	$-0.707 - 0.707i$
3	1	1	-1	$0.707 + 0.707i$	$0.707 + 0.707i$	$-0.707 + 0.707i$
4	-1	-1	1	$-0.707 + 0.707i$	$0.707 + 0.707i$	$-0.707 - 0.707i$
5	-1	1	-1	$-0.707 - 0.707i$	$0.707 + 0.707i$	$0.707 - 0.707i$
6	1	-1	1	$0.707 + 0.707i$	$-0.707 - 0.707i$	-1
7	-1	-1	1	$-0.707 - 0.707i$	$-0.707 + 0.707i$	$-0.707 - 0.707i$
8	-1	1	-1	$-0.707 - 0.707i$	$-0.707 + 0.707i$	$-0.707 - 0.707i$
9	1	1	1	$0.707 + 0.707i$	$0.707 + 0.707i$	$0.707 - 0.707i$
10	-1	-1	-1	-1	$-0.707 - 0.707i$	$0.707 + 0.707i$
11	-1	1	-1	$0.707 - 0.707i$	$-0.707 - 0.707i$	$-0.707 - 0.707i$
12	-1	1	1	$-0.707 - 0.707i$	$-0.707 - 0.707i$	$-0.707 + 0.707i$
13	1	-1	-1	$0.707 - 0.707i$	$-0.707 - 0.707i$	$-0.707 - 0.707i$
14	-1	1	1	$0.707 + 0.707i$	1	$0.707 - 0.707i$
15	$-0 - 1i$	1	$0 + 1i$	$0.707 + 0.707i$	$0.707 + 0.707i$	$-0.707 - 0.707i$
16	$-1 + 0i$	$0 + 1i$	$1 - 0i$	$0.707 + 0.707i$	$0.707 + 0.707i$	$-0.707 + 0.707i$
17	$0 + 1i$	$1 - 0i$	$-0 - 1i$	$0.707 - 0.707i$	$-0.707 + 0.707i$	$0.707 + 0.707i$
18	$-1 + 0i$	$-0 - 1i$	1	$-0.707 + 0.707i$	$-0.707 - 0.707i$	1
19	$0 + 1i$	$-1 + 0i$	$-1 + 0i$	$0.707 - 0.707i$	$0.707 + 0.707i$	$0.707 + 0.707i$
20	$1 - 0i$	$-0 - 1i$	$0 + 1i$	$-0.707 - 0.707i$	$-0.707 - 0.707i$	$0.707 - 0.707i$
21	$0 + 1i$	$-1 + 0i$	$1 - 0i$	$-0.707 - 0.707i$	$-0.707 - 0.707i$	$-0.707 - 0.707i$
22	-1	$-0 - 1i$	$-0 - 1i$	1	$0.707 + 0.707i$	$0.707 + 0.707i$
23	$1 - 0i$	$-1 + 0i$	$-1 + 0i$	$0.707 + 0.707i$	$0.707 - 0.707i$	$0.707 - 0.707i$
24	$-0 - 1i$	$0 + 1i$	$-0 - 1i$	$0.707 - 0.707i$	$0.707 - 0.707i$	$-0.707 - 0.707i$
25	$1 - 0i$	$-1 + 0i$	$-1 + 0i$	$0.707 + 0.707i$	$0.707 + 0.707i$	$-0.707 + 0.707i$
26	$-0 - 1i$	$0 + 1i$	$0 + 1i$	$-0.707 + 0.707i$	$0.707 - 0.707i$	1
27	0	0	0	0	0	0
28	0	0	0	0	0	0
29	0	0	0	0	0	0
30	0	0	0	0	0	0
31	0	0	0	0	0	0

After the IFFT, each symbol is extended by a CP of 16 samples. Each OFDM symbol then has a size of 80 samples (64 +16).

The resulting data in the time domain has 1680 samples (21×80).

M.6 The entire packet

The complete packet in the time domain is represented in Table M.11. The STF is from sample 1 to 320. The LTF is from sample 321 to 480. The OFDM header and payload are from sample 481 to 2160.

Table M.11—Complete packet

Sample	I	Q	Sample	I	Q	Sample	I	Q
1	0.6505	0.0000	721	1.2500	0.2500	1441	0.2500	-0.3536
2	1.0989	0.6505	722	0.8614	-0.4695	1442	0.1638	0.5643
3	0.4600	-1.3010	723	-0.2908	-0.2253	1443	0.7775	0.6229
4	-0.9531	-0.6505	724	0.5001	0.3738	1444	0.9942	0.7243
5	0.0000	0.0000	725	1.1311	-0.9157	1445	0.6081	1.1384
6	0.9531	0.6505	726	-0.4053	-0.2634	1446	0.3631	0.0038
7	-0.4600	1.3010	727	-0.6643	0.4820	1447	-0.4662	0.1814
8	-1.0989	-0.6505	728	1.0328	-0.5564	1448	0.2806	0.4162
9	-0.6505	0.0000	729	0.3750	-0.3750	1449	0.9053	0.0947
10	-1.0989	0.6505	730	-0.0528	-0.5851	1450	0.2529	0.6731
11	-0.4600	-1.3010	731	-0.1631	-0.2493	1451	0.1342	0.4139
12	0.9531	-0.6505	732	-0.8028	1.0475	1452	-1.1735	0.4862
13	0.0000	0.0000	733	0.3377	1.0436	1453	-0.6809	0.1824
14	-0.9531	0.6505	734	0.1681	0.9115	1454	0.8025	-0.7485
15	0.4600	1.3010	735	0.4341	0.3737	1455	0.0997	-0.3608
16	1.0989	-0.6505	736	0.6505	-0.1614	1456	0.3491	-0.7509
17	0.6505	0.0000	737	-0.5000	-0.5000	1457	-0.0732	-0.5303
18	1.0989	0.6505	738	0.5418	-0.1548	1458	-1.3972	0.5182
19	0.4600	-1.3010	739	-0.0330	1.1371	1459	-0.2265	-0.3269
20	-0.9531	-0.6505	740	-0.9736	-0.5277	1460	0.6019	-0.3736

Table M.11—Complete packet (continued)

Sample	I	Q	Sample	I	Q	Sample	I	Q
21	0.0000	0.0000	741	0.2177	-1.2005	1461	-0.9452	0.2922
22	0.9531	0.6505	742	0.2514	1.0265	1462	-0.5092	-0.0185
23	-0.4600	1.3010	743	0.0867	0.3962	1463	0.7862	-0.2370
24	-1.0989	-0.6505	744	0.3458	-0.0062	1464	-0.3930	-0.6599
25	-0.6505	0.0000	745	0.5518	0.3018	1465	-0.2589	-0.3018
26	-1.0989	0.6505	746	-0.1912	0.0665	1466	-0.2738	0.5548
27	-0.4600	-1.3010	747	0.0960	1.0100	1467	-0.3484	-0.1781
28	0.9531	-0.6505	748	0.8195	-0.5387	1468	0.9250	-0.9967
29	0.0000	0.0000	749	-0.8187	-1.0658	1469	-0.6667	-0.0867
30	-0.9531	0.6505	750	-0.2341	0.9365	1470	-0.9835	0.5927
31	0.4600	1.3010	751	0.4301	0.0436	1471	-0.2062	-0.1478
32	1.0989	-0.6505	752	-0.4539	-0.3529	1472	-0.0100	-0.1180
33	0.6505	0.0000	753	0.5000	0.5000	1473	1.3107	0.0000
34	1.0989	0.6505	754	0.0498	0.2651	1474	-0.4684	-0.4770
35	0.4600	-1.3010	755	-0.8625	0.1513	1475	-0.6153	0.7666
36	-0.9531	-0.6505	756	-1.0981	-0.0971	1476	0.4219	1.2002
37	0.0000	0.0000	757	-1.2346	-0.1272	1477	-0.7545	-0.2242
38	0.9531	0.6505	758	-0.1915	-0.8806	1478	0.7262	0.0117
39	-0.4600	1.3010	759	0.3108	-1.2437	1479	0.9370	0.1976
40	-1.0989	-0.6505	760	0.5270	-0.2394	1480	0.2246	-1.4293
41	-0.6505	0.0000	761	0.3750	-0.3750	1481	0.1553	-1.6553
42	-1.0989	0.6505	762	-0.4575	-0.2182	1482	-0.5419	-0.0881
43	-0.4600	-1.3010	763	-0.6075	-0.6365	1483	0.4107	-0.0603
44	0.9531	-0.6505	764	0.5883	-1.4165	1484	-0.3997	-0.6063
45	0.0000	0.0000	765	0.4730	0.4135	1485	-1.0868	0.3176
46	-0.9531	0.6505	766	-1.4108	0.5658	1486	-0.3842	0.3305
47	0.4600	1.3010	767	-0.0805	-0.6480	1487	-0.5168	0.1986

Table M.11—Complete packet (continued)

Sample	I	Q	Sample	I	Q	Sample	I	Q
48	1.0989	-0.6505	768	0.5965	0.1067	1488	0.0383	0.4729
49	0.6505	0.0000	769	-0.7500	0.2500	1489	-0.7803	-0.5303
50	1.0989	0.6505	770	0.1145	0.0399	1490	-0.8118	-0.4881
51	0.4600	-1.3010	771	0.1863	-0.0630	1491	0.7714	-0.3555
52	-0.9531	-0.6505	772	0.7113	-0.9023	1492	1.0368	-0.1270
53	0.0000	0.0000	773	0.3858	-1.2566	1493	0.3846	1.6220
54	0.9531	0.6505	774	-1.2982	-0.2526	1494	-0.2460	0.4268
55	-0.4600	1.3010	775	-0.4403	1.0725	1495	0.4500	-0.8491
56	-1.0989	-0.6505	776	-0.4279	0.5726	1496	-0.6705	0.7903
57	-0.6505	0.0000	777	0.1982	-0.0518	1497	-1.5089	0.4482
58	-1.0989	0.6505	778	0.9624	0.6417	1498	0.6622	-0.2571
59	-0.4600	-1.3010	779	-0.3254	0.8758	1499	0.5106	0.5316
60	0.9531	-0.6505	780	-0.1588	1.0610	1500	0.0076	0.6929
61	0.0000	0.0000	781	-0.4920	1.1086	1501	0.3132	-0.4133
62	-0.9531	0.6505	782	-0.7080	0.3704	1502	-0.1831	-1.5986
63	0.4600	1.3010	783	-0.0765	-0.4764	1503	0.3303	-0.3971
64	1.0989	-0.6505	784	0.1435	-0.3630	1504	0.5951	0.2786
65	0.6505	0.0000	785	1.2500	0.2500	1505	0.2500	-0.3536
66	1.0989	0.6505	786	0.8614	-0.4695	1506	0.1638	0.5643
67	0.4600	-1.3010	787	-0.2908	-0.2253	1507	0.7775	0.6229
68	-0.9531	-0.6505	788	0.5001	0.3738	1508	0.9942	0.7243
69	0.0000	0.0000	789	1.1311	-0.9157	1509	0.6081	1.1384
70	0.9531	0.6505	790	-0.4053	-0.2634	1510	0.3631	0.0038
71	-0.4600	1.3010	791	-0.6643	0.4820	1511	-0.4662	0.1814
72	-1.0989	-0.6505	792	1.0328	-0.5564	1512	0.2806	0.4162
73	-0.6505	0.0000	793	0.3750	-0.3750	1513	0.9053	0.0947
74	-1.0989	0.6505	794	-0.0528	-0.5851	1514	0.2529	0.6731

Table M.11—Complete packet (continued)

Sample	I	Q	Sample	I	Q	Sample	I	Q
75	-0.4600	-1.3010	795	-0.1631	-0.2493	1515	0.1342	0.4139
76	0.9531	-0.6505	796	-0.8028	1.0475	1516	-1.1735	0.4862
77	0.0000	0.0000	797	0.3377	1.0436	1517	-0.6809	0.1824
78	-0.9531	0.6505	798	0.1681	0.9115	1518	0.8025	-0.7485
79	0.4600	1.3010	799	0.4341	0.3737	1519	0.0997	-0.3608
80	1.0989	-0.6505	800	0.6505	-0.1614	1520	0.3491	-0.7509
81	0.6505	0.0000	801	-0.5000	-0.2500	1521	-0.2803	-0.3536
82	1.0989	0.6505	802	-0.0317	0.8648	1522	-0.6641	0.9523
83	0.4600	-1.3010	803	-0.9607	0.0501	1523	-1.1246	-0.2387
84	-0.9531	-0.6505	804	0.7640	-0.2991	1524	0.2415	-0.5844
85	0.0000	0.0000	805	1.1961	0.6546	1525	0.5901	-0.5569
86	0.9531	0.6505	806	0.2388	0.2248	1526	-0.4015	-0.2023
87	-0.4600	1.3010	807	0.0467	0.4232	1527	0.5738	-0.7872
88	-1.0989	-0.6505	808	-0.0033	-0.2475	1528	0.7747	-0.7146
89	-0.6505	0.0000	809	0.3750	-0.8750	1529	-0.3018	0.7714
90	-1.0989	0.6505	810	-0.6716	1.0428	1530	-0.3357	-0.4211
91	-0.4600	-1.3010	811	-0.6920	1.1976	1531	-0.2209	-0.3889
92	0.9531	-0.6505	812	-0.3902	-0.1775	1532	-0.1251	0.0314
93	0.0000	0.0000	813	-0.6083	0.2576	1533	0.3591	-0.8211
94	-0.9531	0.6505	814	0.7307	0.7500	1534	0.1504	0.0247
95	0.4600	1.3010	815	0.0267	0.1909	1535	-0.3983	-0.2610
96	1.0989	-0.6505	816	-1.3111	0.2567	1536	-0.0178	-0.2952
97	0.6505	0.0000	817	-0.7500	0.5000	1537	-0.2500	0.5303
98	1.0989	0.6505	818	-0.4114	-0.5356	1538	-0.8138	0.0300
99	0.4600	-1.3010	819	-0.4178	-0.6116	1539	0.0210	-0.6510
100	-0.9531	-0.6505	820	0.0996	0.3420	1540	-0.0351	-0.6107
101	0.0000	0.0000	821	0.4202	-0.2297	1541	-0.1409	0.2153

Table M.11—Complete packet (continued)

Sample	I	Q	Sample	I	Q	Sample	I	Q
102	0.9531	0.6505	822	-0.8027	-0.7097	1542	1.2834	0.4578
103	-0.4600	1.3010	823	-1.0913	-0.4436	1543	1.0654	1.0381
104	-1.0989	-0.6505	824	-0.1646	-0.3029	1544	-0.2934	0.6271
105	-0.6505	0.0000	825	0.0518	0.4482	1545	-0.6553	-0.2286
106	-1.0989	0.6505	826	0.1405	0.6933	1546	-0.4317	1.7310
107	-0.4600	-1.3010	827	0.1632	-0.2845	1547	0.2617	1.7355
108	0.9531	-0.6505	828	0.8089	-0.6057	1548	0.6881	0.2490
109	0.0000	0.0000	829	0.1654	0.3787	1549	0.0901	0.1012
110	-0.9531	0.6505	830	-0.4424	0.8356	1550	-0.3210	-0.5197
111	0.4600	1.3010	831	1.4504	0.7296	1551	0.6630	-0.6271
112	1.0989	-0.6505	832	1.1508	0.7681	1552	0.1507	-0.7894
113	0.6505	0.0000	833	-0.2500	-0.5000	1553	-1.6945	-0.3536
114	1.0989	0.6505	834	0.5813	-1.2438	1554	-0.3474	-0.1794
115	0.4600	-1.3010	835	0.9020	-0.0004	1555	0.8746	-0.8199
116	-0.9531	-0.6505	836	-0.1068	0.2798	1556	0.1357	0.9088
117	0.0000	0.0000	837	0.4075	-0.4046	1557	0.2635	1.6175
118	0.9531	0.6505	838	0.9756	-0.4730	1558	-0.3064	0.1162
119	-0.4600	1.3010	839	-1.0831	-0.3735	1559	0.4625	0.1133
120	-1.0989	-0.6505	840	-0.8955	-0.8044	1560	1.6210	-0.0821
121	-0.6505	0.0000	841	0.3750	-0.8750	1561	-0.0518	-0.9786
122	-1.0989	0.6505	842	0.2269	-0.2881	1562	0.1806	0.3627
123	-0.4600	-1.3010	843	0.9039	-0.8235	1563	1.1242	0.9063
124	0.9531	-0.6505	844	-0.4775	-0.0295	1564	0.3398	-0.6203
125	0.0000	0.0000	845	-0.2024	1.6995	1565	0.4944	-0.0325
126	-0.9531	0.6505	846	1.1315	0.2718	1566	0.2677	-0.2664
127	0.4600	1.3010	847	-0.6849	-0.3580	1567	0.0108	-0.2596
128	1.0989	-0.6505	848	-0.3707	0.1709	1568	-0.1347	1.6860

Table M.11—Complete packet (continued)

Sample	I	Q	Sample	I	Q	Sample	I	Q
129	0.6505	0.0000	849	0.0000	-0.2500	1569	-0.6036	0.1768
130	1.0989	0.6505	850	-0.3453	0.4325	1570	-0.0350	-0.9562
131	0.4600	-1.3010	851	-0.0236	-0.6453	1571	-0.2710	-0.7903
132	-0.9531	-0.6505	852	-0.5497	-1.1470	1572	-0.4057	-0.4843
133	0.0000	0.0000	853	0.4762	0.4797	1573	-0.0056	0.8454
134	0.9531	0.6505	854	0.7955	-0.7143	1574	-0.5120	-0.6011
135	-0.4600	1.3010	855	0.2134	-0.8132	1575	-0.1875	0.1358
136	-1.0989	-0.6505	856	-0.1436	0.6381	1576	-0.2419	1.3229
137	-0.6505	0.0000	857	-0.3018	0.8018	1577	-0.4053	-0.9786
138	-1.0989	0.6505	858	0.0971	1.4484	1578	0.0331	-0.5193
139	-0.4600	-1.3010	859	-0.8752	0.1175	1579	-0.6650	0.2471
140	0.9531	-0.6505	860	0.2660	-0.7771	1580	-0.4250	0.1105
141	0.0000	0.0000	861	1.1453	0.1642	1581	-0.2365	0.0452
142	-0.9531	0.6505	862	-0.2126	-0.5995	1582	-0.5748	-0.0093
143	0.4600	1.3010	863	0.1219	-0.3554	1583	0.6388	0.6477
144	1.0989	-0.6505	864	-0.6760	-0.0647	1584	0.5556	-0.7546
145	0.6505	0.0000	865	-0.5000	-0.2500	1585	-0.2803	-0.3536
146	1.0989	0.6505	866	-0.0317	0.8648	1586	-0.6641	0.9523
147	0.4600	-1.3010	867	-0.9607	0.0501	1587	-1.1246	-0.2387
148	-0.9531	-0.6505	868	0.7640	-0.2991	1588	0.2415	-0.5844
149	0.0000	0.0000	869	1.1961	0.6546	1589	0.5901	-0.5569
150	0.9531	0.6505	870	0.2388	0.2248	1590	-0.4015	-0.2023
151	-0.4600	1.3010	871	0.0467	0.4232	1591	0.5738	-0.7872
152	-1.0989	-0.6505	872	-0.0033	-0.2475	1592	0.7747	-0.7146
153	-0.6505	0.0000	873	0.3750	-0.8750	1593	-0.3018	0.7714
154	-1.0989	0.6505	874	-0.6716	1.0428	1594	-0.3357	-0.4211
155	-0.4600	-1.3010	875	-0.6920	1.1976	1595	-0.2209	-0.3889

Table M.11—Complete packet (continued)

Sample	I	Q	Sample	I	Q	Sample	I	Q
156	0.9531	-0.6505	876	-0.3902	-0.1775	1596	-0.1251	0.0314
157	0.0000	0.0000	877	-0.6083	0.2576	1597	0.3591	-0.8211
158	-0.9531	0.6505	878	0.7307	0.7500	1598	0.1504	0.0247
159	0.4600	1.3010	879	0.0267	0.1909	1599	-0.3983	-0.2610
160	1.0989	-0.6505	880	-1.3111	0.2567	1600	-0.0178	-0.2952
161	0.6505	0.0000	881	-0.2500	0.2500	1601	-0.5303	0.3536
162	1.0989	0.6505	882	-0.4951	-0.6501	1602	0.0362	0.1951
163	0.4600	-1.3010	883	0.7030	0.1442	1603	1.5894	-0.2734
164	-0.9531	-0.6505	884	-0.6414	-0.3636	1604	1.1743	-0.7905
165	0.0000	0.0000	885	-0.4358	-1.3977	1605	0.0957	-0.2037
166	0.9531	0.6505	886	1.0506	0.2340	1606	0.7194	1.0870
167	-0.4600	1.3010	887	0.0779	-0.1987	1607	-0.4588	0.9484
168	-1.0989	-0.6505	888	-0.6380	-0.1150	1608	-0.7891	-0.1564
169	-0.6505	0.0000	889	-0.2286	0.4786	1609	-0.4268	-0.2197
170	-1.0989	0.6505	890	0.4263	-0.0201	1610	-1.0270	-0.3090
171	-0.4600	-1.3010	891	0.7092	0.9469	1611	0.0165	0.0962
172	0.9531	-0.6505	892	0.6284	0.5555	1612	0.1871	0.3372
173	0.0000	0.0000	893	0.5090	-0.1824	1613	0.3932	-0.8887
174	-0.9531	0.6505	894	-0.5295	0.0510	1614	0.9380	-0.8866
175	0.4600	1.3010	895	-1.0252	-0.5532	1615	0.2672	-0.2544
176	1.0989	-0.6505	896	-0.0839	-1.1538	1616	-0.2780	0.2540
177	0.6505	0.0000	897	0.2500	-0.2500	1617	-0.5303	0.3536
178	1.0989	0.6505	898	-0.5004	1.3005	1618	0.2614	-0.5484
179	0.4600	-1.3010	899	-0.5908	0.6231	1619	-0.8440	0.4400
180	-0.9531	-0.6505	900	0.0577	-0.2707	1620	-1.9533	0.4834
181	0.0000	0.0000	901	-0.1218	-0.4305	1621	-0.2310	-0.6656
182	0.9531	0.6505	902	0.3491	-1.1041	1622	-0.6724	0.7313

Table M.11—Complete packet (continued)

Sample	I	Q	Sample	I	Q	Sample	I	Q
183	-0.4600	1.3010	903	0.9989	-0.6519	1623	-1.0910	0.6826
184	-1.0989	-0.6505	904	-0.4581	0.2200	1624	0.3620	0.3533
185	-0.6505	0.0000	905	-0.3018	0.4053	1625	0.0732	0.6768
186	-1.0989	0.6505	906	1.3908	-0.6853	1626	-1.2539	-0.9391
187	-0.4600	-1.3010	907	0.3587	-1.0781	1627	-0.4299	-0.3482
188	0.9531	-0.6505	908	-0.6375	0.0748	1628	1.1011	0.7877
189	0.0000	0.0000	909	-0.0486	-0.0867	1629	-0.2041	0.2646
190	-0.9531	0.6505	910	-0.6249	-0.0633	1630	-0.3363	0.0068
191	0.4600	1.3010	911	-1.0181	0.3954	1631	0.6177	-0.6401
192	1.0989	-0.6505	912	-0.2391	0.0433	1632	0.3011	0.0302
193	0.6505	0.0000	913	-1.0000	-0.5000	1633	0.1768	0.0000
194	1.0989	0.6505	914	-1.7777	-0.6477	1634	-1.5594	-0.5893
195	0.4600	-1.3010	915	-0.4418	0.0534	1635	-0.4155	0.6856
196	-0.9531	-0.6505	916	0.0513	0.0869	1636	1.9024	-0.2646
197	0.0000	0.0000	917	0.0822	0.0442	1637	-0.0957	-0.8570
198	0.9531	0.6505	918	0.2833	0.1666	1638	-0.2773	-0.1770
199	-0.4600	1.3010	919	-0.6388	0.5428	1639	0.3621	-1.1312
200	-1.0989	-0.6505	920	-0.0179	0.7491	1640	-0.4501	-0.2002
201	-0.6505	0.0000	921	0.4786	-0.2286	1641	0.0732	0.2803
202	-1.0989	0.6505	922	-0.4198	0.6797	1642	0.3684	-0.1857
203	-0.4600	-1.3010	923	0.7210	-0.0705	1643	-0.2665	0.8520
204	0.9531	-0.6505	924	1.2626	-2.0318	1644	-0.3789	0.4118
205	0.0000	0.0000	925	-0.0090	-0.3176	1645	0.3139	0.0352
206	-0.9531	0.6505	926	-0.4956	0.0872	1646	-0.2635	-0.1559
207	0.4600	1.3010	927	0.1654	0.3233	1647	-0.1704	-0.1578
208	1.0989	-0.6505	928	1.0042	0.6618	1648	0.9103	1.4900
209	0.6505	0.0000	929	0.0000	-0.5000	1649	0.1768	0.7071

Table M.11—Complete packet (continued)

Sample	I	Q	Sample	I	Q	Sample	I	Q
210	1.0989	0.6505	930	-0.0522	0.2679	1650	0.1668	-0.3766
211	0.4600	-1.3010	931	1.1226	0.3863	1651	0.1701	0.3549
212	-0.9531	-0.6505	932	0.2618	0.1109	1652	0.3542	-0.2571
213	0.0000	0.0000	933	0.4754	-0.2159	1653	0.2310	-0.3950
214	0.9531	0.6505	934	0.4427	0.0502	1654	-1.5540	-0.2712
215	-0.4600	1.3010	935	-0.5238	1.8078	1655	-0.3123	-0.7069
216	-1.0989	-0.6505	936	0.4607	0.5063	1656	0.4310	0.0159
217	-0.6505	0.0000	937	0.0518	-0.6553	1657	-0.4268	0.6768
218	-1.0989	0.6505	938	0.0141	-0.2449	1658	0.5933	0.3388
219	-0.4600	-1.3010	939	0.4182	-0.0054	1659	0.1799	-0.3929
220	0.9531	-0.6505	940	-0.9829	0.4238	1660	0.0273	-0.2936
221	0.0000	0.0000	941	0.5486	-0.4133	1661	0.9112	-0.1181
222	-0.9531	0.6505	942	0.9385	0.5784	1662	1.0318	-0.7486
223	0.4600	1.3010	943	-1.0362	1.3345	1663	0.7856	-0.1548
224	1.0989	-0.6505	944	-0.0279	0.5026	1664	-0.0730	0.6274
225	0.6505	0.0000	945	-0.2500	0.2500	1665	-0.5303	0.3536
226	1.0989	0.6505	946	-0.4951	-0.6501	1666	0.0362	0.1951
227	0.4600	-1.3010	947	0.7030	0.1442	1667	1.5894	-0.2734
228	-0.9531	-0.6505	948	-0.6414	-0.3636	1668	1.1743	-0.7905
229	0.0000	0.0000	949	-0.4358	-1.3977	1669	0.0957	-0.2037
230	0.9531	0.6505	950	1.0506	0.2340	1670	0.7194	1.0870
231	-0.4600	1.3010	951	0.0779	-0.1987	1671	-0.4588	0.9484
232	-1.0989	-0.6505	952	-0.6380	-0.1150	1672	-0.7891	-0.1564
233	-0.6505	0.0000	953	-0.2286	0.4786	1673	-0.4268	-0.2197
234	-1.0989	0.6505	954	0.4263	-0.0201	1674	-1.0270	-0.3090
235	-0.4600	-1.3010	955	0.7092	0.9469	1675	0.0165	0.0962
236	0.9531	-0.6505	956	0.6284	0.5555	1676	0.1871	0.3372

Table M.11—Complete packet (continued)

Sample	I	Q	Sample	I	Q	Sample	I	Q
237	0.0000	0.0000	957	0.5090	-0.1824	1677	0.3932	-0.8887
238	-0.9531	0.6505	958	-0.5295	0.0510	1678	0.9380	-0.8866
239	0.4600	1.3010	959	-1.0252	-0.5532	1679	0.2672	-0.2544
240	1.0989	-0.6505	960	-0.0839	-1.1538	1680	-0.2780	0.2540
241	0.6505	0.0000	961	0.2500	0.0000	1681	0.1036	0.3536
242	1.0989	0.6505	962	-1.1885	-0.0517	1682	0.0422	0.3606
243	0.4600	-1.3010	963	0.1997	-1.4317	1683	-1.2262	0.7068
244	-0.9531	-0.6505	964	0.9695	-0.3270	1684	0.1929	-0.2507
245	0.0000	0.0000	965	-0.9360	0.8515	1685	0.8657	-1.2428
246	0.9531	0.6505	966	-0.2959	0.2999	1686	0.7129	-0.2952
247	-0.4600	1.3010	967	-0.1250	-0.3056	1687	1.0229	0.8315
248	-1.0989	-0.6505	968	0.4167	-0.1605	1688	0.4230	0.3020
249	-0.6505	0.0000	969	0.4268	0.7500	1689	0.3232	-0.8536
250	-1.0989	0.6505	970	-0.1728	0.7154	1690	-0.7755	-0.8068
251	-0.4600	-1.3010	971	0.3569	0.0708	1691	-0.3816	-0.4457
252	0.9531	-0.6505	972	-0.7639	0.0450	1692	0.0679	-0.9573
253	0.0000	0.0000	973	-0.2207	-0.2286	1693	-1.1094	-0.9405
254	-0.9531	0.6505	974	0.5312	0.1754	1694	-0.4555	-0.9108
255	0.4600	1.3010	975	-1.0181	0.6869	1695	-0.3856	-1.1829
256	1.0989	-0.6505	976	-1.4411	0.1403	1696	0.7023	0.1252
257	0.6505	0.0000	977	-1.2500	0.2500	1697	1.3107	0.3536
258	1.0989	0.6505	978	-0.9559	-0.0985	1698	0.0255	-1.3087
259	0.4600	-1.3010	979	-0.8175	-0.9460	1699	0.7765	-0.4359
260	-0.9531	-0.6505	980	-0.2337	0.1601	1700	-0.0586	0.7280
261	0.0000	0.0000	981	0.1268	0.8224	1701	-0.7558	-0.4427
262	0.9531	0.6505	982	-0.2803	-0.2552	1702	0.1002	0.0806
263	-0.4600	1.3010	983	0.0969	-0.5384	1703	-0.2591	1.4714

Table M.11—Complete packet (continued)

Sample	I	Q	Sample	I	Q	Sample	I	Q
264	-1.0989	-0.6505	984	-0.0805	-0.1178	1704	0.0863	0.9655
265	-0.6505	0.0000	985	0.5303	0.0000	1705	0.3232	0.3964
266	-1.0989	0.6505	986	0.8753	-0.1257	1706	-0.2649	0.0028
267	-0.4600	-1.3010	987	-0.3567	-0.3233	1707	-1.1503	-0.1233
268	0.9531	-0.6505	988	-0.0433	0.0131	1708	0.0217	0.5336
269	0.0000	0.0000	989	0.1060	0.4786	1709	0.5121	0.3163
270	-0.9531	0.6505	990	0.3252	0.1889	1710	-1.3346	-0.1750
271	0.4600	1.3010	991	1.3422	0.0824	1711	0.9100	-0.0053
272	1.0989	-0.6505	992	0.8683	0.2341	1712	1.0668	0.1259
273	0.6505	0.0000	993	-0.2500	-1.0000	1713	-1.3107	0.7071
274	1.0989	0.6505	994	-1.0738	-1.5594	1714	0.0408	0.5515
275	0.4600	-1.3010	995	-1.2715	0.2426	1715	-0.2901	-0.5218
276	-0.9531	-0.6505	996	-0.6137	0.6195	1716	0.2180	0.0159
277	0.0000	0.0000	997	0.8325	-0.4551	1717	0.9450	0.4928
278	0.9531	0.6505	998	1.0492	-0.2092	1718	-0.6200	-0.4164
279	-0.4600	1.3010	999	-0.1345	0.0873	1719	0.5315	-0.0546
280	-1.0989	-0.6505	1000	0.0236	0.4803	1720	0.5828	0.5182
281	-0.6505	0.0000	1001	0.0732	0.7500	1721	-0.6768	-0.3536
282	-1.0989	0.6505	1002	-0.4676	0.1059	1722	-0.3057	-0.4615
283	-0.4600	-1.3010	1003	-0.4764	0.2335	1723	0.0217	0.3982
284	0.9531	-0.6505	1004	-0.3806	-0.1207	1724	0.4884	0.4527
285	0.0000	0.0000	1005	-0.0293	-0.2286	1725	0.0058	-0.0166
286	-0.9531	0.6505	1006	0.8367	1.1749	1726	0.0099	0.1568
287	0.4600	1.3010	1007	0.8917	-0.0067	1727	0.8659	0.6512
288	1.0989	-0.6505	1008	-0.5262	-0.7515	1728	-0.3226	0.4648
289	-0.6505	-0.0000	1009	0.7500	1.2500	1729	-0.8107	0.0000
290	-1.0989	-0.6505	1010	1.4752	-0.0334	1730	0.4962	-0.5399

Table M.11—Complete packet (continued)

Sample	I	Q	Sample	I	Q	Sample	I	Q
291	-0.4600	1.3010	1011	-0.5249	-1.2791	1731	-0.1744	-0.9562
292	0.9531	0.6505	1012	0.8557	0.5252	1732	-0.7985	0.3671
293	0.0000	-0.0000	1013	0.4767	0.2812	1733	0.3594	1.8998
294	-0.9531	-0.6505	1014	-0.9603	-0.3229	1734	0.5597	1.0772
295	0.4600	-1.3010	1015	0.4555	0.0495	1735	0.6190	-0.0412
296	1.0989	0.6505	1016	-0.4136	-0.2559	1736	-0.1555	-0.3080
297	0.6505	0.0000	1017	-0.5303	-0.0000	1737	-0.6768	-0.6036
298	1.0989	-0.6505	1018	0.0939	-0.3668	1738	0.3272	-0.2122
299	0.4600	1.3010	1019	0.8905	-0.5668	1739	-0.4040	-0.0363
300	-0.9531	0.6505	1020	1.6244	0.4992	1740	0.2824	-0.4751
301	0.0000	-0.0000	1021	-0.3560	0.4786	1741	0.5914	-0.0663
302	0.9531	-0.6505	1022	0.2086	0.3624	1742	-1.3867	0.0687
303	-0.4600	-1.3010	1023	0.4913	-0.0555	1743	-0.4761	-0.2558
304	-1.0989	0.6505	1024	-0.2614	-0.9833	1744	0.0312	0.2206
305	-0.6505	-0.0000	1025	0.2500	0.0000	1745	0.1036	0.3536
306	-1.0989	-0.6505	1026	-1.1885	-0.0517	1746	0.0422	0.3606
307	-0.4600	1.3010	1027	0.1997	-1.4317	1747	-1.2262	0.7068
308	0.9531	0.6505	1028	0.9695	-0.3270	1748	0.1929	-0.2507
309	0.0000	-0.0000	1029	-0.9360	0.8515	1749	0.8657	-1.2428
310	-0.9531	-0.6505	1030	-0.2959	0.2999	1750	0.7129	-0.2952
311	0.4600	-1.3010	1031	-0.1250	-0.3056	1751	1.0229	0.8315
312	1.0989	0.6505	1032	0.4167	-0.1605	1752	0.4230	0.3020
313	0.6505	0.0000	1033	0.4268	0.7500	1753	0.3232	-0.8536
314	1.0989	-0.6505	1034	-0.1728	0.7154	1754	-0.7755	-0.8068
315	0.4600	1.3010	1035	0.3569	0.0708	1755	-0.3816	-0.4457
316	-0.9531	0.6505	1036	-0.7639	0.0450	1756	0.0679	-0.9573
317	0.0000	-0.0000	1037	-0.2207	-0.2286	1757	-1.1094	-0.9405

Table M.11—Complete packet (continued)

Sample	I	Q	Sample	I	Q	Sample	I	Q
318	0.9531	−0.6505	1038	0.5312	0.1754	1758	−0.4555	−0.9108
319	−0.4600	−1.3010	1039	−1.0181	0.6869	1759	−0.3856	−1.1829
320	−1.0989	0.6505	1040	−1.4411	0.1403	1760	0.7023	0.1252
321	1.2500	0.0000	1041	−0.5000	−0.5000	1761	0.1036	−0.0000
322	−0.3216	−0.5171	1042	0.0433	0.7037	1762	0.4724	−0.3751
323	−0.5640	−0.4328	1043	−0.5993	−0.3057	1763	0.4547	−0.3261
324	0.8594	0.5478	1044	0.9108	0.4501	1764	−0.7287	−1.4610
325	0.0111	−0.4458	1045	0.4606	1.1643	1765	−0.3515	−1.0093
326	−0.9756	−0.4563	1046	−1.5315	−0.4208	1766	−0.6190	0.7051
327	−1.1903	0.3727	1047	−0.2740	0.3948	1767	0.1962	0.3589
328	−0.7761	−0.0741	1048	−0.3143	0.3605	1768	0.9643	−0.2994
329	0.1036	−0.6339	1049	−0.4786	0.0214	1769	−0.9268	0.3964
330	0.2871	−1.2165	1050	0.7603	−0.2186	1770	−0.1563	0.0105
331	0.4219	−0.6784	1051	0.2119	−0.6767	1771	0.0111	−0.3584
332	0.8836	−0.4284	1052	−0.1467	0.2008	1772	0.1242	0.6776
333	0.5269	0.2276	1053	0.1926	−0.4572	1773	1.0518	0.0182
334	−0.6312	0.5158	1054	0.7408	0.3306	1774	−0.8214	−0.4763
335	−0.3382	−0.9638	1055	0.6994	1.4749	1775	−0.3751	0.9155
336	0.3459	0.1333	1056	−0.4134	0.3684	1776	−0.1545	−0.1655
337	0.2500	1.2500	1057	−0.2500	−0.2500	1777	−0.1036	−1.4142
338	1.0998	0.4827	1058	−0.1028	−0.9568	1778	1.1645	0.1040
339	0.4623	−0.2948	1059	−0.1297	−0.2738	1779	−0.2115	0.6640
340	0.0015	−1.1597	1060	0.3845	0.2946	1780	0.6315	0.6276
341	1.1802	−0.4189	1061	0.3089	0.1433	1781	0.6759	0.6535
342	−0.4653	0.3832	1062	1.0026	0.5946	1782	−0.7752	0.1427
343	−0.6222	0.3373	1063	0.5689	0.1112	1783	0.2895	0.4695
344	0.8113	−0.6423	1064	−0.7639	0.4389	1784	−0.1689	−0.4675

Table M.11—Complete packet (continued)

Sample	I	Q	Sample	I	Q	Sample	I	Q
345	-0.6036	-1.1339	1065	-0.0947	0.0518	1785	-0.2197	-1.3536
346	-0.5391	-0.2070	1066	-0.1534	0.1638	1786	-0.2627	0.1115
347	-0.3165	-1.0258	1067	-0.6016	1.1947	1787	-0.4182	-0.0851
348	-0.5326	-0.3518	1068	-0.1063	-0.3402	1788	0.3393	-0.5796
349	0.2817	0.9077	1069	0.2883	-0.2532	1789	-1.0518	0.5245
350	-0.5541	-0.4205	1070	1.3605	0.0830	1790	-0.6281	0.0242
351	0.1470	-0.1780	1071	1.3150	-0.8342	1791	0.8118	-0.1118
352	0.5069	0.5395	1072	0.0962	-0.1351	1792	0.1943	0.5782
353	-0.7500	0.0000	1073	-0.2500	-0.7500	1793	0.1036	-0.3536
354	0.5069	-0.5395	1074	-0.2277	-1.2176	1794	0.2662	-0.9852
355	0.1470	0.1780	1075	0.2906	-0.0769	1795	0.0390	-0.5212
356	-0.5541	0.4205	1076	0.2231	0.2429	1796	0.1288	0.4527
357	0.2817	-0.9077	1077	-0.7106	0.6463	1797	0.9551	0.7593
358	-0.5326	0.3518	1078	-0.5849	1.4918	1798	0.5840	-0.5119
359	-0.3165	1.0258	1079	0.1879	0.9461	1799	0.4888	-1.0148
360	-0.5391	0.2070	1080	0.6471	0.2784	1800	1.6653	-0.9633
361	-0.6036	1.1339	1081	0.2286	0.7286	1801	0.5732	-0.6036
362	0.8113	0.6423	1082	-0.6522	-0.4000	1802	-0.1919	0.9974
363	-0.6222	-0.3373	1083	-0.2499	-0.2472	1803	-0.4793	0.4731
364	-0.4653	-0.3832	1084	0.7008	1.4607	1804	-0.6392	-0.9603
365	1.1802	0.4189	1085	0.0574	0.0608	1805	1.0518	-0.0611
366	0.0015	1.1597	1086	-1.1170	-0.4262	1806	0.1206	-0.0270
367	0.4623	0.2948	1087	-0.1905	0.4146	1807	-1.2084	-0.6095
368	1.0998	-0.4827	1088	1.3676	-0.5382	1808	0.1610	0.2443
369	0.2500	-1.2500	1089	0.5000	-1.0000	1809	0.6036	0.3536
370	0.3459	-0.1333	1090	-1.2488	-0.0071	1810	-0.0330	-0.3208
371	-0.3382	0.9638	1091	-0.5616	0.6565	1811	-0.4893	-0.3168

Table M.11—Complete packet (continued)

Sample	I	Q	Sample	I	Q	Sample	I	Q
372	-0.6312	-0.5158	1092	0.7246	-0.2170	1812	-0.2124	0.2686
373	0.5269	-0.2276	1093	-0.5589	-0.4539	1813	0.1347	0.3036
374	0.8836	0.4284	1094	-0.5808	-0.8052	1814	-0.7848	-0.4480
375	0.4219	0.6784	1095	0.8101	-1.1592	1815	-1.1817	-0.3136
376	0.2871	1.2165	1096	-0.9704	0.0755	1816	0.8236	0.1532
377	0.1036	0.6339	1097	-1.1553	-0.3018	1817	1.2803	0.1464
378	-0.7761	0.0741	1098	0.5812	-0.4817	1818	-0.6734	0.4578
379	-1.1903	-0.3727	1099	-0.3604	-0.2708	1819	-0.3207	0.4704
380	-0.9756	0.4563	1100	-0.2767	-1.0919	1820	-0.2293	0.9744
381	0.0111	0.4458	1101	-0.0383	-0.8504	1821	-1.0518	1.6397
382	0.8594	-0.5478	1102	-0.2899	-0.4336	1822	-0.4903	0.5912
383	-0.5640	0.4328	1103	0.8831	0.6518	1823	-0.4354	0.3058
384	-0.3216	0.5171	1104	-0.0630	0.1516	1824	-0.0709	0.9201
385	1.2500	0.0000	1105	-0.5000	-0.5000	1825	0.1036	-0.0000
386	-0.3216	-0.5171	1106	0.0433	0.7037	1826	0.4724	-0.3751
387	-0.5640	-0.4328	1107	-0.5993	-0.3057	1827	0.4547	-0.3261
388	0.8594	0.5478	1108	0.9108	0.4501	1828	-0.7287	-1.4610
389	0.0111	-0.4458	1109	0.4606	1.1643	1829	-0.3515	-1.0093
390	-0.9756	-0.4563	1110	-1.5315	-0.4208	1830	-0.6190	0.7051
391	-1.1903	0.3727	1111	-0.2740	0.3948	1831	0.1962	0.3589
392	-0.7761	-0.0741	1112	-0.3143	0.3605	1832	0.9643	-0.2994
393	0.1036	-0.6339	1113	-0.4786	0.0214	1833	-0.9268	0.3964
394	0.2871	-1.2165	1114	0.7603	-0.2186	1834	-0.1563	0.0105
395	0.4219	-0.6784	1115	0.2119	-0.6767	1835	0.0111	-0.3584
396	0.8836	-0.4284	1116	-0.1467	0.2008	1836	0.1242	0.6776
397	0.5269	0.2276	1117	0.1926	-0.4572	1837	1.0518	0.0182
398	-0.6312	0.5158	1118	0.7408	0.3306	1838	-0.8214	-0.4763

Table M.11—Complete packet (continued)

Sample	I	Q	Sample	I	Q	Sample	I	Q
399	-0.3382	-0.9638	1119	0.6994	1.4749	1839	-0.3751	0.9155
400	0.3459	0.1333	1120	-0.4134	0.3684	1840	-0.1545	-0.1655
401	0.2500	1.2500	1121	0.4268	0.0000	1841	-0.1768	-0.1768
402	1.0998	0.4827	1122	0.9942	0.2744	1842	0.2057	0.2223
403	0.4623	-0.2948	1123	0.8211	0.9934	1843	1.2373	-0.9499
404	0.0015	-1.1597	1124	-0.5579	-0.7145	1844	0.2553	0.7366
405	1.1802	-0.4189	1125	0.5426	-0.8084	1845	-0.7106	0.7312
406	-0.4653	0.3832	1126	0.0999	0.2365	1846	-0.2716	0.5028
407	-0.6222	0.3373	1127	0.6684	-0.2380	1847	0.0209	0.2484
408	0.8113	-0.6423	1128	0.9068	-0.3356	1848	-0.2528	-0.9689
409	-0.6036	-1.1339	1129	-1.0089	0.6250	1849	0.0214	0.4786
410	-0.5391	-0.2070	1130	-0.6357	0.4815	1850	0.3021	0.5310
411	-0.3165	-1.0258	1131	-0.0194	-0.6036	1851	-0.5490	0.3853
412	-0.5326	-0.3518	1132	-0.3315	-0.4134	1852	-0.2408	0.9165
413	0.2817	0.9077	1133	-1.1746	-0.0325	1853	0.6625	-0.6419
414	-0.5541	-0.4205	1134	-1.1141	-0.1848	1854	-0.1478	-0.8287
415	0.1470	-0.1780	1135	0.4767	0.3437	1855	-0.8396	0.4183
416	0.5069	0.5395	1136	1.4635	0.9359	1856	-0.9431	0.5037
417	-0.7500	0.0000	1137	1.1642	0.8839	1857	-0.3536	-0.7071
418	0.5069	-0.5395	1138	0.2222	-0.1226	1858	-0.0471	-0.4611
419	0.1470	0.1780	1139	1.2852	-0.7261	1859	-0.8091	0.2708
420	-0.5541	0.4205	1140	0.2144	0.1598	1860	0.2917	-0.0909
421	0.2817	-0.9077	1141	-1.8866	0.4675	1861	0.5589	1.0515
422	-0.5326	0.3518	1142	0.8386	-0.0904	1862	-1.0034	0.7154
423	-0.3165	1.0258	1143	0.8794	-0.2545	1863	-0.4469	-0.3087
424	-0.5391	0.2070	1144	-0.9852	0.0991	1864	-0.3645	0.5322
425	-0.6036	1.1339	1145	-0.4482	0.1250	1865	-0.8321	0.6250

Table M.11—Complete packet (continued)

Sample	I	Q	Sample	I	Q	Sample	I	Q
426	0.8113	0.6423	1146	-0.3526	-0.6340	1866	-0.0434	1.0456
427	-0.6222	-0.3373	1147	0.5120	-0.6626	1867	0.0346	0.9160
428	-0.4653	-0.3832	1148	0.3663	-0.0058	1868	-0.1049	0.0397
429	1.1802	0.4189	1149	0.1012	0.3988	1869	-0.1071	0.4109
430	0.0015	1.1597	1150	0.0250	0.1928	1870	0.4521	0.3763
431	0.4623	0.2948	1151	-1.0216	-0.4521	1871	0.2505	-0.8598
432	1.0998	-0.4827	1152	0.2780	-0.0794	1872	-0.9069	-1.6128
433	0.2500	-1.2500	1153	0.4268	0.0000	1873	0.5303	-0.8839
434	0.3459	-0.1333	1154	-0.8237	0.0886	1874	0.9339	-0.2754
435	-0.3382	0.9638	1155	0.2687	0.9754	1875	-0.0903	0.4024
436	-0.6312	-0.5158	1156	0.9688	-0.2707	1876	1.1442	0.0882
437	0.5269	-0.2276	1157	0.1039	-0.7523	1877	0.4606	-0.9812
438	0.8836	0.4284	1158	-0.4116	0.4042	1878	-0.3106	0.5294
439	0.4219	0.6784	1159	-0.2857	-0.3069	1879	1.1006	0.4852
440	0.2871	1.2165	1160	-0.9435	-0.3838	1880	0.3853	-0.4966
441	0.1036	0.6339	1161	-0.7589	-0.1250	1881	-0.7286	0.2286
442	-0.7761	0.0741	1162	0.2256	0.0617	1882	-0.6466	-0.9123
443	-1.1903	-0.3727	1163	-0.1973	0.9191	1883	-0.1899	-0.8948
444	-0.9756	0.4563	1164	-0.2651	-0.4020	1884	0.1959	0.1607
445	0.0111	0.4458	1165	-0.3860	-0.8211	1885	-0.2054	-0.3152
446	0.8594	-0.5478	1166	-0.5318	0.3122	1886	0.2126	0.4633
447	-0.5640	0.4328	1167	0.4471	0.1473	1887	0.6165	1.4357
448	-0.3216	0.5171	1168	0.6556	0.7202	1888	0.6900	0.4237
449	1.2500	0.0000	1169	-0.6036	0.5303	1889	0.7071	-0.3536
450	-0.3216	-0.5171	1170	-1.4825	-0.2403	1890	-0.7636	0.1854
451	-0.5640	-0.4328	1171	-0.9608	0.4645	1891	-0.5450	-0.9304
452	0.8594	0.5478	1172	-0.7596	0.3665	1892	0.6692	-1.0943

Table M.11—Complete packet (continued)

Sample	I	Q	Sample	I	Q	Sample	I	Q
453	0.0111	-0.4458	1173	-0.1741	-0.3211	1893	-0.3089	0.6127
454	-0.9756	-0.4563	1174	-0.3101	-0.5504	1894	-0.3160	0.1540
455	-1.1903	0.3727	1175	-1.2621	0.0923	1895	0.5325	-0.2178
456	-0.7761	-0.0741	1176	0.4985	0.3137	1896	0.2097	-1.0443
457	0.1036	-0.6339	1177	0.8018	-0.6250	1897	-0.5821	-0.6250
458	0.2871	-1.2165	1178	0.4383	0.0908	1898	-1.3552	1.0788
459	0.4219	-0.6784	1179	1.1190	0.0542	1899	-0.5029	-0.6137
460	0.8836	-0.4284	1180	-0.2210	-0.7201	1900	1.2036	-0.1707
461	0.5269	0.2276	1181	0.0452	0.4548	1901	1.0642	0.5462
462	-0.6312	0.5158	1182	-0.0100	-0.3203	1902	-0.0295	-0.4982
463	-0.3382	-0.9638	1183	0.0977	-0.7461	1903	0.1797	0.2128
464	0.3459	0.1333	1184	1.5405	0.7300	1904	0.5965	-0.7512
465	0.2500	1.2500	1185	0.4268	0.0000	1905	-0.1768	-0.1768
466	1.0998	0.4827	1186	0.9942	0.2744	1906	0.2057	0.2223
467	0.4623	-0.2948	1187	0.8211	0.9934	1907	1.2373	-0.9499
468	0.0015	-1.1597	1188	-0.5579	-0.7145	1908	0.2553	0.7366
469	1.1802	-0.4189	1189	0.5426	-0.8084	1909	-0.7106	0.7312
470	-0.4653	0.3832	1190	0.0999	0.2365	1910	-0.2716	0.5028
471	-0.6222	0.3373	1191	0.6684	-0.2380	1911	0.0209	0.2484
472	0.8113	-0.6423	1192	0.9068	-0.3356	1912	-0.2528	-0.9689
473	-0.6036	-1.1339	1193	-1.0089	0.6250	1913	0.0214	0.4786
474	-0.5391	-0.2070	1194	-0.6357	0.4815	1914	0.3021	0.5310
475	-0.3165	-1.0258	1195	-0.0194	-0.6036	1915	-0.5490	0.3853
476	-0.5326	-0.3518	1196	-0.3315	-0.4134	1916	-0.2408	0.9165
477	0.2817	0.9077	1197	-1.1746	-0.0325	1917	0.6625	-0.6419
478	-0.5541	-0.4205	1198	-1.1141	-0.1848	1918	-0.1478	-0.8287
479	0.1470	-0.1780	1199	0.4767	0.3437	1919	-0.8396	0.4183

Table M.11—Complete packet (continued)

Sample	I	Q	Sample	I	Q	Sample	I	Q
480	0.5069	0.5395	1200	1.4635	0.9359	1920	-0.9431	0.5037
481	0.7500	-0.2500	1201	-0.3536	0.3536	1921	-0.8839	-0.0000
482	0.0030	0.0383	1202	-0.6225	0.5404	1922	-0.5281	0.5001
483	-0.4024	0.3583	1203	-0.1716	-0.2718	1923	-0.0039	0.6801
484	1.1517	0.1295	1204	-1.1936	0.9375	1924	-0.5595	0.8308
485	-0.3571	-0.3694	1205	0.0378	0.0018	1925	-0.7917	0.7297
486	-0.7863	0.3638	1206	0.6464	-1.0822	1926	0.0089	-0.0110
487	1.0069	-0.1142	1207	-0.3420	-0.3460	1927	-0.3694	0.3613
488	-0.5347	-0.4360	1208	-0.1094	0.6579	1928	1.2119	-0.1508
489	-0.3750	0.6250	1209	-0.7071	0.9268	1929	0.9786	0.1982
490	1.1394	0.9180	1210	-0.5974	0.1001	1930	-0.9843	0.0442
491	0.4178	-0.2132	1211	-0.1627	0.0859	1931	0.3119	-1.3171
492	0.5319	-1.1776	1212	-0.4667	-0.1517	1932	0.4241	0.2268
493	-0.1049	-0.8631	1213	0.0621	-0.1260	1933	0.2341	0.8348
494	-0.7085	-0.4467	1214	-0.8100	-0.1574	1934	0.5149	0.4050
495	-0.2948	0.2850	1215	-0.1639	-0.7336	1935	-0.5881	0.7871
496	-0.9447	0.4838	1216	1.8775	0.1407	1936	0.1107	-0.0131
497	-1.0000	0.0000	1217	0.0000	0.3536	1937	0.7071	-0.1768
498	-0.9515	-0.5292	1218	-0.8706	0.3725	1938	-0.2172	0.4891
499	-0.2478	-0.8458	1219	0.7309	0.9490	1939	0.3772	0.5686
500	0.3843	0.4523	1220	0.9331	0.5853	1940	1.1447	-0.7164
501	-0.9125	0.2151	1221	1.2651	-0.0004	1941	0.1512	-0.9046
502	-0.1435	-0.6271	1222	1.0011	-0.8286	1942	-0.1850	0.3940
503	0.3474	0.3114	1223	0.1323	-1.1359	1943	-0.4407	-0.6066
504	-0.8656	0.3428	1224	0.4767	-0.4300	1944	-1.0693	-0.4243
505	0.3018	-0.0518	1225	0.3536	0.1768	1945	0.4786	1.1982
506	0.2228	-0.7921	1226	-0.1387	-0.3935	1946	0.2871	-0.0292

Table M.11—Complete packet (continued)

Sample	I	Q	Sample	I	Q	Sample	I	Q
507	-0.5604	0.4037	1227	0.1789	-0.2136	1947	-1.0934	-0.9223
508	0.4847	1.2827	1228	0.1915	0.6976	1948	0.0522	0.1653
509	-0.1467	-1.2331	1229	0.1001	-0.5542	1949	0.2151	0.5092
510	-0.3911	-0.5139	1230	0.3944	-0.5866	1950	0.2336	0.1295
511	0.7517	0.6241	1231	-0.3075	0.0715	1951	0.0364	0.4178
512	0.6166	-0.4875	1232	-0.4025	-0.1733	1952	-1.0535	0.0147
513	0.0000	-0.5000	1233	1.0607	0.7071	1953	-0.1768	-0.7071
514	-0.9321	-0.9455	1234	0.5718	-0.3410	1954	-0.0343	0.0856
515	-1.0664	-0.7119	1235	-0.4817	-0.6970	1955	-0.4263	0.1259
516	0.4203	-0.4174	1236	-0.1156	0.7601	1956	0.3872	-0.6964
517	0.8142	-0.2341	1237	-0.3913	0.3517	1957	0.1882	0.0203
518	0.3200	-0.3035	1238	0.1652	0.3614	1958	0.0580	1.1376
519	0.6083	-0.3635	1239	0.8420	0.8783	1959	0.8377	0.1773
520	0.1902	1.3675	1240	-0.4186	0.5227	1960	0.8912	-1.1723
521	-0.3750	0.6250	1241	-0.7071	-0.5732	1961	-0.2714	-0.5518
522	0.2095	-0.1602	1242	0.4162	-0.5313	1962	-1.4707	-0.1450
523	-0.1435	0.5668	1243	0.4333	0.4464	1963	-0.7802	-0.2215
524	-0.8200	0.1545	1244	-0.5802	-0.0762	1964	0.9120	-0.4707
525	-0.3522	0.4667	1245	-0.2085	0.0653	1965	0.3694	-0.8777
526	0.1479	-0.5213	1246	0.6231	0.3207	1966	-0.1358	-0.4220
527	0.7156	0.2688	1247	-0.3361	-0.2352	1967	1.0183	-0.5932
528	-0.0925	1.3591	1248	-0.4128	-0.9630	1968	-0.0851	-0.1486
529	-1.2500	-0.7500	1249	0.0000	-0.7071	1969	-1.0607	0.1768
530	0.1279	0.2831	1250	-0.4614	1.0275	1970	-0.6981	-0.5970
531	1.0095	0.4922	1251	-0.0777	0.3126	1971	-0.1541	0.1253
532	0.6112	-1.0248	1252	-1.0066	0.7308	1972	1.3468	0.2628
533	-0.0446	-0.1115	1253	-1.6186	1.7681	1973	-0.2547	0.1546

Table M.11—Complete packet (continued)

Sample	I	Q	Sample	I	Q	Sample	I	Q
534	-1.4091	-0.2039	1254	0.1112	-0.6989	1974	-0.7423	0.3398
535	-0.9626	-0.2479	1255	0.3677	-1.1035	1975	1.1795	-0.4320
536	0.0253	0.2034	1256	0.1275	-0.5023	1976	-0.2495	-1.0368
537	-0.0518	0.3018	1257	0.3536	0.1768	1977	0.2286	-1.5518
538	0.5953	0.1876	1258	-0.2974	-0.1890	1978	1.2315	0.0664
539	0.9932	-0.0501	1259	-0.4495	-2.0258	1979	0.3546	0.9608
540	1.0643	0.1866	1260	0.2381	-0.0692	1980	0.7067	-0.0164
541	1.1038	0.1295	1261	0.7534	-0.0923	1981	-0.1115	0.9479
542	0.5564	1.2525	1262	-0.1313	-0.7426	1982	-0.1665	0.4414
543	-0.1725	1.2363	1263	-0.1925	1.1902	1983	-0.2595	-0.1117
544	-0.2230	-0.4189	1264	0.8617	0.1615	1984	-1.3421	0.5170
545	0.7500	-0.2500	1265	-0.3536	0.3536	1985	-0.8839	-0.0000
546	0.0030	0.0383	1266	-0.6225	0.5404	1986	-0.5281	0.5001
547	-0.4024	0.3583	1267	-0.1716	-0.2718	1987	-0.0039	0.6801
548	1.1517	0.1295	1268	-1.1936	0.9375	1988	-0.5595	0.8308
549	-0.3571	-0.3694	1269	0.0378	0.0018	1989	-0.7917	0.7297
550	-0.7863	0.3638	1270	0.6464	-1.0822	1990	0.0089	-0.0110
551	1.0069	-0.1142	1271	-0.3420	-0.3460	1991	-0.3694	0.3613
552	-0.5347	-0.4360	1272	-0.1094	0.6579	1992	1.2119	-0.1508
553	-0.3750	0.6250	1273	-0.7071	0.9268	1993	0.9786	0.1982
554	1.1394	0.9180	1274	-0.5974	0.1001	1994	-0.9843	0.0442
555	0.4178	-0.2132	1275	-0.1627	0.0859	1995	0.3119	-1.3171
556	0.5319	-1.1776	1276	-0.4667	-0.1517	1996	0.4241	0.2268
557	-0.1049	-0.8631	1277	0.0621	-0.1260	1997	0.2341	0.8348
558	-0.7085	-0.4467	1278	-0.8100	-0.1574	1998	0.5149	0.4050
559	-0.2948	0.2850	1279	-0.1639	-0.7336	1999	-0.5881	0.7871
560	-0.9447	0.4838	1280	1.8775	0.1407	2000	0.1107	-0.0131

Table M.11—Complete packet (continued)

Sample	I	Q	Sample	I	Q	Sample	I	Q
561	0.5000	0.0000	1281	0.8839	0.5303	2001	-0.4268	0.3536
562	-0.3085	-0.2892	1282	0.5424	-0.0022	2002	-1.0574	-0.1440
563	-0.1437	-0.2565	1283	-0.5860	-0.5003	2003	-0.7470	0.4266
564	-0.1802	0.2279	1284	0.4166	0.2304	2004	0.3722	1.3037
565	0.2839	-0.2244	1285	1.3276	-0.4516	2005	-0.1084	0.3042
566	-0.8160	-0.8546	1286	0.1451	-0.7357	2006	-1.1934	-0.5430
567	-1.6074	0.3079	1287	0.3228	0.1189	2007	-0.3996	-0.1660
568	0.7877	-0.1511	1288	-0.6096	0.6574	2008	0.6821	-0.6570
569	0.3750	-0.8321	1289	-1.0303	0.7071	2009	-0.1768	-0.3232
570	-0.9921	-0.2920	1290	0.1291	-1.0814	2010	-1.9805	0.3039
571	-0.0893	-0.4812	1291	0.2828	-0.7487	2011	-1.1431	-0.8739
572	-0.1895	0.4323	1292	-0.0971	0.7849	2012	1.0910	-0.3047
573	0.3314	1.4226	1293	-0.8863	-0.8433	2013	0.7119	0.0045
574	0.4784	0.5251	1294	0.2760	-0.4223	2014	0.5305	-0.1432
575	0.1954	-0.1440	1295	1.1043	0.1005	2015	1.1243	0.7097
576	1.1669	0.2835	1296	0.0984	-0.8117	2016	-0.4017	-0.5379
577	0.7500	-0.2500	1297	0.5303	1.2374	2017	-0.6339	0.7071
578	0.7536	0.0435	1298	0.6691	0.9030	2018	0.8179	1.2678
579	0.5296	0.7304	1299	0.0706	-0.6003	2019	0.7275	-1.0177
580	-0.6150	-1.1478	1300	-0.4665	0.5808	2020	0.4730	0.1557
581	0.4857	-0.2386	1301	-0.9180	0.2603	2021	0.1622	-0.3311
582	0.3202	1.5452	1302	-1.1723	-0.3012	2022	-0.6697	-0.8676
583	-0.0228	0.2686	1303	-0.9438	-0.5155	2023	-0.6594	0.1583
584	1.5213	0.2369	1304	-0.0858	-0.4900	2024	-0.4641	-0.8158
585	0.4053	0.0518	1305	0.0732	0.6464	2025	-0.6768	0.5732
586	-0.7148	0.3455	1306	0.4904	0.5272	2026	-0.8257	1.1738
587	0.0196	0.6050	1307	-0.3957	0.3213	2027	-0.6350	-0.2757

Table M.11—Complete packet (continued)

Sample	I	Q	Sample	I	Q	Sample	I	Q
588	-0.0255	-0.6389	1308	-0.9791	0.1224	2028	-0.5510	-0.6712
589	-0.1971	0.1324	1309	0.3974	-0.0552	2029	-0.4413	-0.4395
590	-0.3794	0.3976	1310	-0.9349	0.8005	2030	0.8945	0.4371
591	0.1334	-0.3895	1311	-0.6716	0.3852	2031	1.3260	0.3028
592	0.3540	-0.6079	1312	1.0813	0.1325	2032	0.1681	0.5123
593	-0.7500	0.2500	1313	0.5303	0.5303	2033	0.2803	0.0000
594	-0.2563	1.2112	1314	0.8554	0.2168	2034	-0.1132	0.0082
595	0.2901	-0.0178	1315	-0.3734	-0.1593	2035	-1.0167	1.3556
596	-0.9078	0.3924	1316	-0.8737	-0.7140	2036	0.2982	-0.4010
597	-0.8874	0.1815	1317	0.4830	0.2016	2037	0.8155	-0.1577
598	-0.0706	-1.4117	1318	0.0811	0.1980	2038	0.2434	0.3889
599	0.4541	-0.2286	1319	0.2158	-1.1283	2039	0.8186	-1.3076
600	1.2821	0.3947	1320	-0.0028	0.3368	2040	0.4914	0.0773
601	0.3750	0.5821	1321	-0.0303	0.7071	2041	-0.1768	0.1768
602	-0.7421	-0.0435	1322	0.4445	0.1774	2042	0.3101	-0.5701
603	0.9429	-0.2804	1323	0.1025	0.5099	2043	0.4566	-0.3089
604	1.0435	0.7421	1324	0.4375	-1.5122	2044	-0.0392	-0.4203
605	-0.7278	-0.6726	1325	-0.4244	-1.1139	2045	-0.2119	0.8491
606	-0.2412	0.0818	1326	-1.4370	1.1767	2046	0.5225	0.9202
607	-0.4248	1.2592	1327	-0.5277	0.3932	2047	0.7947	0.2765
608	-0.6098	0.2982	1328	0.2555	0.4147	2048	0.0461	-0.4595
609	1.0000	0.5000	1329	-0.5303	1.2374	2049	0.0732	-1.0607
610	0.3883	-0.6949	1330	-0.7963	0.6254	2050	0.1815	-0.1955
611	-0.3832	-1.1632	1331	0.3888	0.0528	2051	0.1220	0.0283
612	0.2529	-1.0497	1332	-0.1884	-0.1511	2052	0.7169	-0.0711
613	-0.3821	-1.2185	1333	-0.1855	-0.0103	2053	0.5449	-0.5224
614	-0.5456	0.0679	1334	0.5994	0.3515	2054	0.2181	0.5755

Table M.11—Complete packet (continued)

Sample	I	Q	Sample	I	Q	Sample	I	Q
615	0.1761	-0.3479	1335	-0.0948	0.3178	2055	0.1546	1.5224
616	0.0176	-0.5926	1336	0.1211	-0.9407	2056	-0.2317	-0.8476
617	-0.6553	-0.3018	1337	-0.4268	-1.3536	2057	0.3232	-0.4268
618	-0.1281	-0.2806	1338	-0.3345	0.0480	2058	0.2530	0.5701
619	0.8339	0.8637	1339	0.5104	-0.2895	2059	-0.5927	-0.7486
620	-0.2068	1.0417	1340	-0.2493	-0.7555	2060	0.0531	-0.0054
621	-0.9064	0.6176	1341	0.2061	0.5981	2061	-0.0587	0.2930
622	-0.7457	-0.3512	1342	0.4426	0.3467	2062	-0.9602	-0.3537
623	-0.9040	-0.7257	1343	0.5950	-1.0860	2063	-0.3308	-0.0820
624	0.3086	0.1382	1344	1.1419	-0.7133	2064	0.1240	0.3139
625	0.5000	0.0000	1345	0.8839	0.5303	2065	-0.4268	0.3536
626	-0.3085	-0.2892	1346	0.5424	-0.0022	2066	-1.0574	-0.1440
627	-0.1437	-0.2565	1347	-0.5860	-0.5003	2067	-0.7470	0.4266
628	-0.1802	0.2279	1348	0.4166	0.2304	2068	0.3722	1.3037
629	0.2839	-0.2244	1349	1.3276	-0.4516	2069	-0.1084	0.3042
630	-0.8160	-0.8546	1350	0.1451	-0.7357	2070	-1.1934	-0.5430
631	-1.6074	0.3079	1351	0.3228	0.1189	2071	-0.3996	-0.1660
632	0.7877	-0.1511	1352	-0.6096	0.6574	2072	0.6821	-0.6570
633	0.3750	-0.8321	1353	-1.0303	0.7071	2073	-0.1768	-0.3232
634	-0.9921	-0.2920	1354	0.1291	-1.0814	2074	-1.9805	0.3039
635	-0.0893	-0.4812	1355	0.2828	-0.7487	2075	-1.1431	-0.8739
636	-0.1895	0.4323	1356	-0.0971	0.7849	2076	1.0910	-0.3047
637	0.3314	1.4226	1357	-0.8863	-0.8433	2077	0.7119	0.0045
638	0.4784	0.5251	1358	0.2760	-0.4223	2078	0.5305	-0.1432
639	0.1954	-0.1440	1359	1.1043	0.1005	2079	1.1243	0.7097
640	1.1669	0.2835	1360	0.0984	-0.8117	2080	-0.4017	-0.5379
641	-0.2500	0.0000	1361	0.6036	0.1768	2081	-0.5303	-0.3536

Table M.11—Complete packet (continued)

Sample	I	Q	Sample	I	Q	Sample	I	Q
642	0.0992	-0.0286	1362	0.3992	-1.0879	2082	-0.2412	-1.2369
643	0.2191	-0.0721	1363	-0.5504	-0.9586	2083	0.0325	0.1695
644	-0.0967	-0.3706	1364	-0.7227	-0.5638	2084	0.4862	1.0950
645	-0.3298	-0.5272	1365	-0.6228	-0.5814	2085	0.9334	0.8104
646	-0.5840	-1.1713	1366	0.1130	-0.5003	2086	0.0086	0.4289
647	-0.5644	0.3122	1367	0.2416	0.7555	2087	-0.1074	0.2087
648	0.1361	0.8877	1368	-0.4563	0.7879	2088	0.3809	-0.8744
649	0.4053	0.4053	1369	-0.8750	-1.1553	2089	0.1982	-0.6250
650	0.4374	0.4681	1370	-1.1105	-0.0629	2090	1.0224	0.4850
651	-0.4830	-0.3086	1371	-0.1102	0.8284	2091	0.4970	-0.5663
652	-0.6867	0.3758	1372	0.3078	-0.6422	2092	-0.6378	-0.5282
653	1.2357	0.8089	1373	0.1150	-0.2262	2093	-0.3108	-0.2804
654	0.7685	-0.3674	1374	0.4227	0.4172	2094	-0.6898	0.0300
655	-0.0880	-0.0741	1375	0.8959	0.2667	2095	-0.6495	0.5202
656	0.9866	0.1074	1376	0.5364	0.2204	2096	-1.0067	-1.4767
657	0.2500	-0.5000	1377	-1.1339	-0.3536	2097	-1.7678	-0.8839
658	0.2423	0.7199	1378	0.4379	0.1646	2098	-0.6350	0.3694
659	1.0962	0.1399	1379	1.5486	1.1206	2099	-0.0401	-0.7119
660	0.0096	-1.6950	1380	-0.7839	-0.2537	2100	0.3445	-0.1592
661	-0.3425	0.7375	1381	-0.1530	-1.0100	2101	0.1146	0.2084
662	0.0573	1.0281	1382	0.8392	0.0443	2102	-0.9477	-0.1312
663	-0.1529	-0.8073	1383	0.7233	-0.1368	2103	0.4526	-0.3851
664	-0.4811	0.2484	1384	0.5130	0.0888	2104	0.5693	-0.0263
665	0.0821	-0.1250	1385	-0.4786	-0.0518	2105	-0.9053	0.2714
666	0.9896	0.6340	1386	0.3072	-0.5150	2106	-0.1578	-0.6136
667	-0.0324	1.0040	1387	0.7393	1.2424	2107	0.3078	-0.5199
668	-0.1874	-0.4979	1388	0.6595	0.9815	2108	-0.1159	-0.4045

Table M.11—Complete packet (continued)

Sample	I	Q	Sample	I	Q	Sample	I	Q
669	1.0339	0.9606	1389	0.2244	-0.1961	2109	-0.9539	0.0764
670	0.0446	0.6331	1390	-0.3663	0.4254	2110	-0.3503	0.3097
671	-0.5489	-0.5532	1391	0.9627	-0.3578	2111	1.8126	0.2959
672	0.2882	-0.0798	1392	0.5409	-1.1903	2112	0.7345	1.2949
673	0.0000	0.2500	1393	0.2500	-0.1768	2113	-0.1768	0.0000
674	-0.3759	0.6592	1394	0.6212	0.6789	2114	0.7882	-0.3846
675	0.1053	-0.3486	1395	-0.7450	-0.2470	2115	-0.3143	-0.2344
676	0.0885	0.0458	1396	-0.0148	-0.2338	2116	-0.0822	-0.2293
677	-0.2738	0.0701	1397	0.1657	0.4778	2117	0.8773	2.0609
678	0.6387	-0.2059	1398	-0.7455	-0.3693	2118	-0.1874	-0.0983
679	0.6885	1.4272	1399	-0.0076	0.6541	2119	-0.0570	-1.3096
680	-0.7073	-0.2506	1400	0.3384	0.9275	2120	0.2189	1.0353
681	-0.6553	-0.6553	1401	0.8750	-0.4053	2121	-0.5518	-0.3750
682	-0.9597	0.3345	1402	0.1610	0.0387	2122	-0.2132	-0.4174
683	-1.1480	-1.3066	1403	-1.4526	-0.3014	2123	0.3005	0.6567
684	0.2966	-0.9211	1404	-1.1354	-0.0623	2124	0.1283	0.5511
685	0.3679	-0.0589	1405	-0.8650	-0.1702	2125	0.2072	0.2375
686	0.0273	0.5144	1406	-0.1794	-1.4749	2126	0.1004	-0.7112
687	-0.1122	0.2945	1407	0.9121	-1.0485	2127	-0.2475	-0.0472
688	-0.0229	-0.5413	1408	-0.0716	-0.5569	2128	-0.1488	-0.0826
689	1.5000	0.7500	1409	-0.4268	0.3536	2129	-0.3536	0.5303
690	1.1877	0.5099	1410	0.4655	0.2444	2130	-0.2946	1.2521
691	-0.0064	-0.7191	1411	0.0398	-0.2079	2131	0.0289	-0.9302
692	0.3178	-0.5477	1412	0.1386	0.5101	2132	-0.3657	-0.7065
693	0.4461	0.2196	1413	-0.0970	-0.3007	2133	0.9032	0.4558
694	0.6586	0.4125	1414	-0.8240	0.8253	2134	2.0504	-0.1994
695	-0.2642	-0.2250	1415	0.1640	1.4343	2135	0.4189	-0.2211

Table M.11—Complete packet (continued)

Sample	I	Q	Sample	I	Q	Sample	I	Q
696	-1.7320	0.2993	1416	-0.3190	-0.4976	2136	-0.2454	-0.1345
697	-1.3321	-0.1250	1417	-0.2286	0.1982	2137	-0.1553	0.0214
698	-0.6206	-0.8828	1418	0.7183	0.5393	2138	-0.2687	0.5459
699	0.2492	-0.3888	1419	-0.8835	-0.0622	2139	0.6018	0.7224
700	0.6725	-0.2177	1420	-0.4492	0.2642	2140	0.2427	0.3816
701	-0.1374	-0.2106	1421	-0.1815	0.5925	2141	-0.3567	0.6736
702	-0.6110	-1.2578	1422	-1.2597	0.6324	2142	0.0158	0.3715
703	-0.9579	-0.3743	1423	0.3506	-0.1533	2143	-0.2085	-0.4761
704	-0.8819	1.1574	1424	0.9181	0.2202	2144	-0.5029	0.2644
705	-0.2500	0.0000	1425	0.6036	0.1768	2145	-0.5303	-0.3536
706	0.0992	-0.0286	1426	0.3992	-1.0879	2146	-0.2412	-1.2369
707	0.2191	-0.0721	1427	-0.5504	-0.9586	2147	0.0325	0.1695
708	-0.0967	-0.3706	1428	-0.7227	-0.5638	2148	0.4862	1.0950
709	-0.3298	-0.5272	1429	-0.6228	-0.5814	2149	0.9334	0.8104
710	-0.5840	-1.1713	1430	0.1130	-0.5003	2150	0.0086	0.4289
711	-0.5644	0.3122	1431	0.2416	0.7555	2151	-0.1074	0.2087
712	0.1361	0.8877	1432	-0.4563	0.7879	2152	0.3809	-0.8744
713	0.4053	0.4053	1433	-0.8750	-1.1553	2153	0.1982	-0.6250
714	0.4374	0.4681	1434	-1.1105	-0.0629	2154	1.0224	0.4850
715	-0.4830	-0.3086	1435	-0.1102	0.8284	2155	0.4970	-0.5663
716	-0.6867	0.3758	1436	0.3078	-0.6422	2156	-0.6378	-0.5282
717	1.2357	0.8089	1437	0.1150	-0.2262	2157	-0.3108	-0.2804
718	0.7685	-0.3674	1438	0.4227	0.4172	2158	-0.6898	0.0300
719	-0.0880	-0.0741	1439	0.8959	0.2667	2159	-0.6495	0.5202
720	0.9866	0.1074	1440	0.5364	0.2204	2160	-1.0067	-1.4767

Insert after new Annex M the following new annex (Annex N):

Annex N

(informative)

Example of encoding a packet for MR-O-QPSK PHY

N.1 Introduction

The purpose of this annex is to show an example of encoding a packet for the MR-QPSK PHY, as described in 18.3. In particular, generation of the PPDU chip sequence, c_{PPDU} , is described in detail.

The frequency band used in this example is the 470 MHz band, implying a chip rate of 100 kchip/s. This example uses RateMode zero, which corresponds to a PSDU data rate of 6.25 kb/s.

The encoding illustration goes through the following stages:

- a) Generating the bit sequence of the SHR
- b) Applying BDE to the bit sequence
- c) Applying $(32,1)_0$ -DSSS to the bit sequence to obtain the chip sequences c_{SHR}
- d) Generating the bit sequence of the PHR
- e) Extending the bit sequence by appending six, zero bits
- f) Encoding the bit sequence of the PHR with a rate 1/2 convolutional encoder
- g) Interleaving of the code-bit sequence
- h) Applying BDE to the code-bit sequence
- i) Applying $(8,1)_{0/1}$ -DSSS to the code-bit sequence to obtain c_{PHR}
- j) Generating the bit sequence of the PSDU
- k) Extending the bit sequence by appending six, zero bits and pad bits
- l) Encoding the bit sequence of the PSDU with a rate 1/2 convolutional encoder
- m) Interleaving of the code-bit sequence
- n) Applying BDE to the code-bit sequence
- o) Applying $(8,1)_{0/1}$ -DSSS to the code-bit sequence
- p) Insertion of pilot sequences to the chip sequence of the PSDU section, obtaining the chip sequence c_{PSDU}
- q) Concatenation $c_{PPDU} = \{c_{SHR}, c_{PHR}, c_{PSDU}\}$

In this example, all binary sequences of length n are treated as bit strings:

$b_0 b_1 \dots b_{n-1}$

The corresponding entries are processed b_0 first to b_{n-1} last.

N.2 The message

The example payload of 7 octets is shown in Table N.1. It constitutes an acknowledgment frame with a 3-octet MHR and a 4-octet FCS, as defined in 5.2.1.9.

Table N.1—The message

Octet #	Value (Hex)	Octet #	Value (Hex)	Octet #	Value (Hex)	Octet #	Value (Hex)
0	02	2	6A	4	94	6	14
1	00	3	BA	5	5F		

N.3 Generation of the SHR

The fixed bit sequence of the SHR, consisting of four, zero preamble octets and two SFD octets, is given as

0000 0000 0000 0000 0000 0000 0000 0000 1110 1011 0110 0010

After BDE, this sequence changes to the following:

$$b_{SHR}^{BDE} = 0000\ 0000\ 0000\ 0000\ 0000\ 0000\ 0000\ 0000\ 1011\ 0010\ 0100\ 0011 \quad (L.1)$$

Each bit of the sequence b_{SHR}^{BDE} is mapped to the corresponding chip sequence with regard to (32,1)₀-DSSS. The final sequence of chips, c_{SHR} , is shown in Table N.2.

Table N.2—Chip sequence c_{SHR}

Chip #	Chip value	Chip #	Chip value	Chip #	Chip value	Chip #	Chip value
0	1	384	1	768	1	1152	1
1	1	385	1	769	1	1153	1
2	0	386	0	770	0	1154	0
3	1	387	1	771	1	1155	1
4	1	388	1	772	1	1156	1
5	1	389	1	773	1	1157	1
6	1	390	1	774	1	1158	1
7	0	391	0	775	0	1159	0
8	1	392	1	776	1	1160	1
9	0	393	0	777	0	1161	0
10	1	394	1	778	1	1162	1
11	0	395	0	779	0	1163	0
12	0	396	0	780	0	1164	0
13	0	397	0	781	0	1165	0

Table N.2—Chip sequence c_{SHR} (continued)

Chip #	Chip value	Chip #	Chip value	Chip #	Chip value	Chip #	Chip value
14	1	398	1	782	1	1166	1
15	0	399	0	783	0	1167	0
16	0	400	0	784	0	1168	0
17	1	401	1	785	1	1169	1
18	1	402	1	786	1	1170	1
19	1	403	1	787	1	1171	1
20	0	404	0	788	0	1172	0
21	0	405	0	789	0	1173	0
22	0	406	0	790	0	1174	0
23	0	407	0	791	0	1175	0
24	0	408	0	792	0	1176	0
25	1	409	1	793	1	1177	1
26	1	410	1	794	1	1178	1
27	0	411	0	795	0	1179	0
28	0	412	0	796	0	1180	0
29	1	413	1	797	1	1181	1
30	0	414	0	798	0	1182	0
31	1	415	1	799	1	1183	1
32	1	416	1	800	1	1184	1
33	1	417	1	801	1	1185	1
34	0	418	0	802	0	1186	0
35	1	419	1	803	1	1187	1
36	1	420	1	804	1	1188	1
37	1	421	1	805	1	1189	1
38	1	422	1	806	1	1190	1
39	0	423	0	807	0	1191	0
40	1	424	1	808	1	1192	1
41	0	425	0	809	0	1193	0
42	1	426	1	810	1	1194	1
43	0	427	0	811	0	1195	0
44	0	428	0	812	0	1196	0
45	0	429	0	813	0	1197	0
46	1	430	1	814	1	1198	1

Table N.2—Chip sequence c_{SHR} (continued)

Chip #	Chip value	Chip #	Chip value	Chip #	Chip value	Chip #	Chip value
47	0	431	0	815	0	1199	0
48	0	432	0	816	0	1200	0
49	1	433	1	817	1	1201	1
50	1	434	1	818	1	1202	1
51	1	435	1	819	1	1203	1
52	0	436	0	820	0	1204	0
53	0	437	0	821	0	1205	0
54	0	438	0	822	0	1206	0
55	0	439	0	823	0	1207	0
56	0	440	0	824	0	1208	0
57	1	441	1	825	1	1209	1
58	1	442	1	826	1	1210	1
59	0	443	0	827	0	1211	0
60	0	444	0	828	0	1212	0
61	1	445	1	829	1	1213	1
62	0	446	0	830	0	1214	0
63	1	447	1	831	1	1215	1
64	1	448	1	832	1	1216	0
65	1	449	1	833	1	1217	0
66	0	450	0	834	0	1218	1
67	1	451	1	835	1	1219	0
68	1	452	1	836	1	1220	0
69	1	453	1	837	1	1221	0
70	1	454	1	838	1	1222	0
71	0	455	0	839	0	1223	1
72	1	456	1	840	1	1224	0
73	0	457	0	841	0	1225	1
74	1	458	1	842	1	1226	0
75	0	459	0	843	0	1227	1
76	0	460	0	844	0	1228	1
77	0	461	0	845	0	1229	1
78	1	462	1	846	1	1230	0
79	0	463	0	847	0	1231	1

Table N.2—Chip sequence c_{SHR} (continued)

Chip #	Chip value	Chip #	Chip value	Chip #	Chip value	Chip #	Chip value
80	0	464	0	848	0	1232	1
81	1	465	1	849	1	1233	0
82	1	466	1	850	1	1234	0
83	1	467	1	851	1	1235	0
84	0	468	0	852	0	1236	1
85	0	469	0	853	0	1237	1
86	0	470	0	854	0	1238	1
87	0	471	0	855	0	1239	1
88	0	472	0	856	0	1240	1
89	1	473	1	857	1	1241	0
90	1	474	1	858	1	1242	0
91	0	475	0	859	0	1243	1
92	0	476	0	860	0	1244	1
93	1	477	1	861	1	1245	0
94	0	478	0	862	0	1246	1
95	1	479	1	863	1	1247	0
96	1	480	1	864	1	1248	1
97	1	481	1	865	1	1249	1
98	0	482	0	866	0	1250	0
99	1	483	1	867	1	1251	1
100	1	484	1	868	1	1252	1
101	1	485	1	869	1	1253	1
102	1	486	1	870	1	1254	1
103	0	487	0	871	0	1255	0
104	1	488	1	872	1	1256	1
105	0	489	0	873	0	1257	0
106	1	490	1	874	1	1258	1
107	0	491	0	875	0	1259	0
108	0	492	0	876	0	1260	0
109	0	493	0	877	0	1261	0
110	1	494	1	878	1	1262	1
111	0	495	0	879	0	1263	0
112	0	496	0	880	0	1264	0

Table N.2—Chip sequence c_{SHR} (continued)

Chip #	Chip value	Chip #	Chip value	Chip #	Chip value	Chip #	Chip value
113	1	497	1	881	1	1265	1
114	1	498	1	882	1	1266	1
115	1	499	1	883	1	1267	1
116	0	500	0	884	0	1268	0
117	0	501	0	885	0	1269	0
118	0	502	0	886	0	1270	0
119	0	503	0	887	0	1271	0
120	0	504	0	888	0	1272	0
121	1	505	1	889	1	1273	1
122	1	506	1	890	1	1274	1
123	0	507	0	891	0	1275	0
124	0	508	0	892	0	1276	0
125	1	509	1	893	1	1277	1
126	0	510	0	894	0	1278	0
127	1	511	1	895	1	1279	1
128	1	512	1	896	1	1280	1
129	1	513	1	897	1	1281	1
130	0	514	0	898	0	1282	0
131	1	515	1	899	1	1283	1
132	1	516	1	900	1	1284	1
133	1	517	1	901	1	1285	1
134	1	518	1	902	1	1286	1
135	0	519	0	903	0	1287	0
136	1	520	1	904	1	1288	1
137	0	521	0	905	0	1289	0
138	1	522	1	906	1	1290	1
139	0	523	0	907	0	1291	0
140	0	524	0	908	0	1292	0
141	0	525	0	909	0	1293	0
142	1	526	1	910	1	1294	1
143	0	527	0	911	0	1295	0
144	0	528	0	912	0	1296	0
145	1	529	1	913	1	1297	1

Table N.2—Chip sequence c_{SHR} (continued)

Chip #	Chip value	Chip #	Chip value	Chip #	Chip value	Chip #	Chip value
146	1	530	1	914	1	1298	1
147	1	531	1	915	1	1299	1
148	0	532	0	916	0	1300	0
149	0	533	0	917	0	1301	0
150	0	534	0	918	0	1302	0
151	0	535	0	919	0	1303	0
152	0	536	0	920	0	1304	0
153	1	537	1	921	1	1305	1
154	1	538	1	922	1	1306	1
155	0	539	0	923	0	1307	0
156	0	540	0	924	0	1308	0
157	1	541	1	925	1	1309	1
158	0	542	0	926	0	1310	0
159	1	543	1	927	1	1311	1
160	1	544	1	928	1	1312	0
161	1	545	1	929	1	1313	0
162	0	546	0	930	0	1314	1
163	1	547	1	931	1	1315	0
164	1	548	1	932	1	1316	0
165	1	549	1	933	1	1317	0
166	1	550	1	934	1	1318	0
167	0	551	0	935	0	1319	1
168	1	552	1	936	1	1320	0
169	0	553	0	937	0	1321	1
170	1	554	1	938	1	1322	0
171	0	555	0	939	0	1323	1
172	0	556	0	940	0	1324	1
173	0	557	0	941	0	1325	1
174	1	558	1	942	1	1326	0
175	0	559	0	943	0	1327	1
176	0	560	0	944	0	1328	1
177	1	561	1	945	1	1329	0
178	1	562	1	946	1	1330	0

Table N.2—Chip sequence c_{SHR} (continued)

Chip #	Chip value	Chip #	Chip value	Chip #	Chip value	Chip #	Chip value
179	1	563	1	947	1	1331	0
180	0	564	0	948	0	1332	1
181	0	565	0	949	0	1333	1
182	0	566	0	950	0	1334	1
183	0	567	0	951	0	1335	1
184	0	568	0	952	0	1336	1
185	1	569	1	953	1	1337	0
186	1	570	1	954	1	1338	0
187	0	571	0	955	0	1339	1
188	0	572	0	956	0	1340	1
189	1	573	1	957	1	1341	0
190	0	574	0	958	0	1342	1
191	1	575	1	959	1	1343	0
192	1	576	1	960	1	1344	1
193	1	577	1	961	1	1345	1
194	0	578	0	962	0	1346	0
195	1	579	1	963	1	1347	1
196	1	580	1	964	1	1348	1
197	1	581	1	965	1	1349	1
198	1	582	1	966	1	1350	1
199	0	583	0	967	0	1351	0
200	1	584	1	968	1	1352	1
201	0	585	0	969	0	1353	0
202	1	586	1	970	1	1354	1
203	0	587	0	971	0	1355	0
204	0	588	0	972	0	1356	0
205	0	589	0	973	0	1357	0
206	1	590	1	974	1	1358	1
207	0	591	0	975	0	1359	0
208	0	592	0	976	0	1360	0
209	1	593	1	977	1	1361	1
210	1	594	1	978	1	1362	1
211	1	595	1	979	1	1363	1

Table N.2—Chip sequence c_{SHR} (continued)

Chip #	Chip value	Chip #	Chip value	Chip #	Chip value	Chip #	Chip value
212	0	596	0	980	0	1364	0
213	0	597	0	981	0	1365	0
214	0	598	0	982	0	1366	0
215	0	599	0	983	0	1367	0
216	0	600	0	984	0	1368	0
217	1	601	1	985	1	1369	1
218	1	602	1	986	1	1370	1
219	0	603	0	987	0	1371	0
220	0	604	0	988	0	1372	0
221	1	605	1	989	1	1373	1
222	0	606	0	990	0	1374	0
223	1	607	1	991	1	1375	1
224	1	608	1	992	1	1376	1
225	1	609	1	993	1	1377	1
226	0	610	0	994	0	1378	0
227	1	611	1	995	1	1379	1
228	1	612	1	996	1	1380	1
229	1	613	1	997	1	1381	1
230	1	614	1	998	1	1382	1
231	0	615	0	999	0	1383	0
232	1	616	1	1000	1	1384	1
233	0	617	0	1001	0	1385	0
234	1	618	1	1002	1	1386	1
235	0	619	0	1003	0	1387	0
236	0	620	0	1004	0	1388	0
237	0	621	0	1005	0	1389	0
238	1	622	1	1006	1	1390	1
239	0	623	0	1007	0	1391	0
240	0	624	0	1008	0	1392	0
241	1	625	1	1009	1	1393	1
242	1	626	1	1010	1	1394	1
243	1	627	1	1011	1	1395	1
244	0	628	0	1012	0	1396	0

Table N.2—Chip sequence c_{SHR} (continued)

Chip #	Chip value	Chip #	Chip value	Chip #	Chip value	Chip #	Chip value
245	0	629	0	1013	0	1397	0
246	0	630	0	1014	0	1398	0
247	0	631	0	1015	0	1399	0
248	0	632	0	1016	0	1400	0
249	1	633	1	1017	1	1401	1
250	1	634	1	1018	1	1402	1
251	0	635	0	1019	0	1403	0
252	0	636	0	1020	0	1404	0
253	1	637	1	1021	1	1405	1
254	0	638	0	1022	0	1406	0
255	1	639	1	1023	1	1407	1
256	1	640	1	1024	0	1408	1
257	1	641	1	1025	0	1409	1
258	0	642	0	1026	1	1410	0
259	1	643	1	1027	0	1411	1
260	1	644	1	1028	0	1412	1
261	1	645	1	1029	0	1413	1
262	1	646	1	1030	0	1414	1
263	0	647	0	1031	1	1415	0
264	1	648	1	1032	0	1416	1
265	0	649	0	1033	1	1417	0
266	1	650	1	1034	0	1418	1
267	0	651	0	1035	1	1419	0
268	0	652	0	1036	1	1420	0
269	0	653	0	1037	1	1421	0
270	1	654	1	1038	0	1422	1
271	0	655	0	1039	1	1423	0
272	0	656	0	1040	1	1424	0
273	1	657	1	1041	0	1425	1
274	1	658	1	1042	0	1426	1
275	1	659	1	1043	0	1427	1
276	0	660	0	1044	1	1428	0
277	0	661	0	1045	1	1429	0

Table N.2—Chip sequence c_{SHR} (continued)

Chip #	Chip value	Chip #	Chip value	Chip #	Chip value	Chip #	Chip value
278	0	662	0	1046	1	1430	0
279	0	663	0	1047	1	1431	0
280	0	664	0	1048	1	1432	0
281	1	665	1	1049	0	1433	1
282	1	666	1	1050	0	1434	1
283	0	667	0	1051	1	1435	0
284	0	668	0	1052	1	1436	0
285	1	669	1	1053	0	1437	1
286	0	670	0	1054	1	1438	0
287	1	671	1	1055	0	1439	1
288	1	672	1	1056	1	1440	1
289	1	673	1	1057	1	1441	1
290	0	674	0	1058	0	1442	0
291	1	675	1	1059	1	1443	1
292	1	676	1	1060	1	1444	1
293	1	677	1	1061	1	1445	1
294	1	678	1	1062	1	1446	1
295	0	679	0	1063	0	1447	0
296	1	680	1	1064	1	1448	1
297	0	681	0	1065	0	1449	0
298	1	682	1	1066	1	1450	1
299	0	683	0	1067	0	1451	0
300	0	684	0	1068	0	1452	0
301	0	685	0	1069	0	1453	0
302	1	686	1	1070	1	1454	1
303	0	687	0	1071	0	1455	0
304	0	688	0	1072	0	1456	0
305	1	689	1	1073	1	1457	1
306	1	690	1	1074	1	1458	1
307	1	691	1	1075	1	1459	1
308	0	692	0	1076	0	1460	0
309	0	693	0	1077	0	1461	0
310	0	694	0	1078	0	1462	0

Table N.2—Chip sequence c_{SHR} (continued)

Chip #	Chip value	Chip #	Chip value	Chip #	Chip value	Chip #	Chip value
311	0	695	0	1079	0	1463	0
312	0	696	0	1080	0	1464	0
313	1	697	1	1081	1	1465	1
314	1	698	1	1082	1	1466	1
315	0	699	0	1083	0	1467	0
316	0	700	0	1084	0	1468	0
317	1	701	1	1085	1	1469	1
318	0	702	0	1086	0	1470	0
319	1	703	1	1087	1	1471	1
320	1	704	1	1088	0	1472	0
321	1	705	1	1089	0	1473	0
322	0	706	0	1090	1	1474	1
323	1	707	1	1091	0	1475	0
324	1	708	1	1092	0	1476	0
325	1	709	1	1093	0	1477	0
326	1	710	1	1094	0	1478	0
327	0	711	0	1095	1	1479	1
328	1	712	1	1096	0	1480	0
329	0	713	0	1097	1	1481	1
330	1	714	1	1098	0	1482	0
331	0	715	0	1099	1	1483	1
332	0	716	0	1100	1	1484	1
333	0	717	0	1101	1	1485	1
334	1	718	1	1102	0	1486	0
335	0	719	0	1103	1	1487	1
336	0	720	0	1104	1	1488	1
337	1	721	1	1105	0	1489	0
338	1	722	1	1106	0	1490	0
339	1	723	1	1107	0	1491	0
340	0	724	0	1108	1	1492	1
341	0	725	0	1109	1	1493	1
342	0	726	0	1110	1	1494	1
343	0	727	0	1111	1	1495	1

Table N.2—Chip sequence c_{SHR} (continued)

Chip #	Chip value	Chip #	Chip value	Chip #	Chip value	Chip #	Chip value
344	0	728	0	1112	1	1496	1
345	1	729	1	1113	0	1497	0
346	1	730	1	1114	0	1498	0
347	0	731	0	1115	1	1499	1
348	0	732	0	1116	1	1500	1
349	1	733	1	1117	0	1501	0
350	0	734	0	1118	1	1502	1
351	1	735	1	1119	0	1503	0
352	1	736	1	1120	0	1504	0
353	1	737	1	1121	0	1505	0
354	0	738	0	1122	1	1506	1
355	1	739	1	1123	0	1507	0
356	1	740	1	1124	0	1508	0
357	1	741	1	1125	0	1509	0
358	1	742	1	1126	0	1510	0
359	0	743	0	1127	1	1511	1
360	1	744	1	1128	0	1512	0
361	0	745	0	1129	1	1513	1
362	1	746	1	1130	0	1514	0
363	0	747	0	1131	1	1515	1
364	0	748	0	1132	1	1516	1
365	0	749	0	1133	1	1517	1
366	1	750	1	1134	0	1518	0
367	0	751	0	1135	1	1519	1
368	0	752	0	1136	1	1520	1
369	1	753	1	1137	0	1521	0
370	1	754	1	1138	0	1522	0
371	1	755	1	1139	0	1523	0
372	0	756	0	1140	1	1524	1
373	0	757	0	1141	1	1525	1

Table N.2—Chip sequence c_{SHR} (continued)

Chip #	Chip value	Chip #	Chip value	Chip #	Chip value	Chip #	Chip value
374	0	758	0	1142	1	1526	1
375	0	759	0	1143	1	1527	1
376	0	760	0	1144	1	1528	1
377	1	761	1	1145	0	1529	0
378	1	762	1	1146	0	1530	0
379	0	763	0	1147	1	1531	1
380	0	764	0	1148	1	1532	1
381	1	765	1	1149	0	1533	0
382	0	766	0	1150	1	1534	1
383	1	767	1	1151	0	1535	0

N.4 Generation of the PHR

The Spreading Mode (SM) field is set to zero (DSSS applied to the PSDU), the Rate Mode field (R_1 , R_0) is set to (0,0) corresponding to RateMode zero, the Reserved field entries are set to (0,0), and the Length field entries are set to the binary representation of “7,” corresponding to the PSDU length of the frame. The complete PHR field including the HCS field (H_7 – H_0) is shown in Table N.3.

Table N.3—PHR for MR-O-QPSK

Bit #	0	1	2	3	4	5–15	16–23
Bit mapping	SM	RM_1	RM_0	R_1	R_0	L_{10} – L_0	H_7 – H_0
value	0	0	0	0	0	0 0 0 0 0 0 0 0 1 1 1	00010101

After padding the 24 information bits by 6 additional zero termination bits, the sequence of the 60 code-bits at the output of convolutional encoding is given as follows:

0000 0000 0000 0000 0000 0000 0011 1001 0100 0110 0011 1000 0000 0111 1011

The sequences after 10×6 interleaving is given as

1000 0010 1100 0011 0010 0100 1000 0011 0000 1110 0001 0000 0010 0000 0000

After BDE, the code-bit sequence changes to

0000 0011 0111 1101 1100 0111 0000 0010 0000 1011 1110 0000 0011 1111 1111

Note that for bit-differential encoding of the PHR code-bits, the first reference value is the last sample of b_{SHR}^{BDE} , which is equal to one, as described in Equation (L.1).

Each bit of the code-bit sequence is mapped to the corresponding chip sequence with regard to $(8,1)_{0/1}$ -DSSS. The final PHR chip sequence, c_{PHR} , is shown in Table N.4.

Table N.4—Chip sequence c_{PHR}

Chip #	Chip value	Chip #	Chip value	Chip #	Chip value	Chip #	Chip value
0	1	120	1	240	0	360	0
1	0	121	0	241	1	361	1
2	1	122	0	242	0	362	1
3	1	123	1	243	0	363	0
4	0	124	1	244	1	364	0
5	0	125	1	245	1	365	0
6	0	126	0	246	1	366	1
7	1	127	0	247	0	367	1
8	0	128	0	248	0	368	1
9	1	129	1	249	1	369	0
10	1	130	0	250	1	370	1
11	0	131	0	251	0	371	1
12	0	132	1	252	0	372	0
13	0	133	1	253	0	373	0
14	1	134	1	254	1	374	0
15	1	135	0	255	1	375	1
16	1	136	1	256	1	376	0
17	0	137	0	257	0	377	1
18	1	138	0	258	1	378	1
19	1	139	1	259	1	379	0
20	0	140	1	260	0	380	0
21	0	141	1	261	0	381	0
22	0	142	0	262	0	382	1
23	1	143	0	263	1	383	1
24	0	144	1	264	0	384	1
25	1	145	0	265	1	385	0
26	1	146	1	266	1	386	1
27	0	147	1	267	0	387	1
28	0	148	0	268	0	388	0
29	0	149	0	269	0	389	0
30	1	150	0	270	1	390	0

Table N.4—Chip sequence c_{PHR} (continued)

Chip #	Chip value	Chip #	Chip value	Chip #	Chip value	Chip #	Chip value
31	1	151	1	271	1	391	1
32	1	152	0	272	1	392	0
33	0	153	1	273	0	393	1
34	1	154	1	274	1	394	1
35	1	155	0	275	1	395	0
36	0	156	0	276	0	396	0
37	0	157	0	277	0	397	0
38	0	158	1	278	0	398	1
39	1	159	1	279	1	399	1
40	0	160	1	280	0	400	0
41	1	161	0	281	1	401	1
42	1	162	1	282	1	402	0
43	0	163	1	283	0	403	0
44	0	164	0	284	0	404	1
45	0	165	0	285	0	405	1
46	1	166	0	286	1	406	1
47	1	167	1	287	1	407	0
48	0	168	1	288	0	408	1
49	1	169	0	289	1	409	0
50	0	170	0	290	0	410	0
51	0	171	1	291	0	411	1
52	1	172	1	292	1	412	1
53	1	173	1	293	1	413	1
54	1	174	0	294	1	414	0
55	0	175	0	295	0	415	0
56	1	176	0	296	0	416	0
57	0	177	1	297	1	417	1
58	0	178	0	298	1	418	0
59	1	179	0	299	0	419	0
60	1	180	1	300	0	420	1
61	1	181	1	301	0	421	1
62	0	182	1	302	1	422	1
63	0	183	0	303	1	423	0

Table N.4—Chip sequence c_{PHR} (continued)

Chip #	Chip value	Chip #	Chip value	Chip #	Chip value	Chip #	Chip value
64	1	184	1	304	0	424	1
65	0	185	0	305	1	425	0
66	1	186	0	306	0	426	0
67	1	187	1	307	0	427	1
68	0	188	1	308	1	428	1
69	0	189	1	309	1	429	1
70	0	190	0	310	1	430	0
71	1	191	0	311	0	431	0
72	1	192	1	312	1	432	0
73	0	193	0	313	0	433	1
74	0	194	1	314	0	434	0
75	1	195	1	315	1	435	0
76	1	196	0	316	1	436	1
77	1	197	0	317	1	437	1
78	0	198	0	318	0	438	1
79	0	199	1	319	0	439	0
80	0	200	0	320	0	440	1
81	1	201	1	321	1	441	0
82	0	202	1	322	0	442	0
83	0	203	0	323	0	443	1
84	1	204	0	324	1	444	1
85	1	205	0	325	1	445	1
86	1	206	1	326	1	446	0
87	0	207	1	327	0	447	0
88	1	208	1	328	1	448	0
89	0	209	0	329	0	449	1
90	0	210	1	330	0	450	0
91	1	211	1	331	1	451	0
92	1	212	0	332	1	452	1
93	1	213	0	333	1	453	1
94	0	214	0	334	0	454	1
95	0	215	1	335	0	455	0
96	0	216	0	336	0	456	1

Table N.4—Chip sequence c_{PHR} (continued)

Chip #	Chip value	Chip #	Chip value	Chip #	Chip value	Chip #	Chip value
97	1	217	1	337	1	457	0
98	0	218	1	338	0	458	0
99	0	219	0	339	0	459	1
100	1	220	0	340	1	460	1
101	1	221	0	341	1	461	1
102	1	222	1	342	1	462	0
103	0	223	1	343	0	463	0
104	1	224	1	344	0	464	0
105	0	225	0	345	1	465	1
106	0	226	1	346	1	466	0
107	1	227	1	347	0	467	0
108	1	228	0	348	0	468	1
109	1	229	0	349	0	469	1
110	0	230	0	350	1	470	1
111	0	231	1	351	1	471	0
112	1	232	0	352	1	472	1
113	0	233	1	353	0	473	0
114	1	234	1	354	1	474	0
115	1	235	0	355	1	475	1
116	0	236	0	356	0	476	1
117	0	237	0	357	0	477	1
118	0	238	1	358	0	478	0
119	1	239	1	359	1	479	0

N.5 Generation of the PSDU

The bit sequence of the example PSDU is

$$b_{PSDU} = 0100\ 0000\ 0000\ 0000\ 0101\ 0110\ 0101\ 1101\ 0010\ 1001\ 1111\ 1010\ 0010\ 1000$$

Note that for each message octet given in Table N.1, the least significant bit is processed first in time.

Prior to convolutional encoding, this bit sequence needs to be extended by six, zero termination bits and one additional zero pad bit, such that the overall length is $N_{INTRLV}/2 = 63$.

$$b_{PSDU}^{ext} = 0100\ 0000\ 0000\ 0000\ 0101\ 0110\ 0101\ 1101\ 0010\ 1001\ 1111\ 1010\ 0010\ 1000\ 0000\ 000$$

The corresponding sequence of 126 code-bits would be the following:

0011 0111 1100 1011 0000 0000 0000 0000 0011 0100 1000 1101 1011 1101 1001 1100 0010 0110 1001
1110 0111 0110 0000 1011 1010 0011 1110 1101 1110 1100 0000 00

The sequences after 18×7 interleaving is

0000 1100 1011 1001 0110 1011 0101 0110 0000 1011 0100 1010 0001 0000 1010 1011 1001 0100 0100
1111 1001 1111 0011 1101 0010 1000 1010 1001 1001 1001 0100 00

For BDE, computation of M according to Equation (10) is required. For the example, this yields $M = 512/8 = 64$. Hence, the reference value is zero for the computation of E_n at index $n = 0$ and $n = 64$, and E_{n-1} for all other indices. Accordingly, the bit-differentially encoded code-bit sequence is

0000 1000 1101 0001 1011 0010 0110 0100 0000 1101 1000 1100 0001 1111 0011 0010 1110 0111 1000
1010 1110 1010 0010 1001 1100 1111 0011 0001 0001 0001 1000 00

Each bit of the code-bit sequence needs to be mapped to the corresponding chip sequence with regard to $(8,1)_{0/1}$ -DSSS, delivering a chip sequence $u = \{u_0, \dots, u_{126 \times 8 - 1}\}$. In order to obtain the final PSDU chip sequence, $L = \text{ceil}(126/M) = 2$ instances of the pilot sequence

1101 1110 1010 0010 0111 0000 0110 0101

need to be inserted into the sequence u . The first pilot instance is preceding sample u_0 , and the second instance is to be inserted between samples u_{511} and u_{512} . The PSDU chip sequence including the pilots, c_{PSDU} , is shown in Table N.5.

Table N.5—Chip sequence c_{PSDU}

Chip #	Chip value	Chip #	Chip value	Chip #	Chip value	Chip #	Chip value
0	1	268	1	536	0	804	1
1	1	269	1	537	1	805	1
2	0	270	0	538	1	806	1
3	1	271	0	539	0	807	0
4	1	272	1	540	0	808	0
5	1	273	0	541	0	809	1
6	1	274	1	542	1	810	1
7	0	275	1	543	1	811	0
8	1	276	0	544	1	812	0
9	0	277	0	545	1	813	0
10	1	278	0	546	0	814	1
11	0	279	1	547	1	815	1
12	0	280	0	548	1	816	1
13	0	281	1	549	1	817	0
14	1	282	1	550	1	818	1

Table N.5—Chip sequence c_{PSDU} (continued)

Chip #	Chip value	Chip #	Chip value	Chip #	Chip value	Chip #	Chip value
15	0	283	0	551	0	819	1
16	0	284	0	552	1	820	0
17	1	285	0	553	0	821	0
18	1	286	1	554	1	822	0
19	1	287	1	555	0	823	1
20	0	288	1	556	0	824	1
21	0	289	0	557	0	825	0
22	0	290	1	558	1	826	0
23	0	291	1	559	0	827	1
24	0	292	0	560	0	828	1
25	1	293	0	561	1	829	1
26	1	294	0	562	1	830	0
27	0	295	1	563	1	831	0
28	0	296	0	564	0	832	0
29	1	297	1	565	0	833	1
30	0	298	1	566	0	834	0
31	1	299	0	567	0	835	0
32	1	300	0	568	0	836	1
33	0	301	0	569	1	837	1
34	1	302	1	570	1	838	1
35	1	303	1	571	0	839	0
36	0	304	1	572	0	840	1
37	0	305	0	573	1	841	0
38	0	306	1	574	0	842	0
39	1	307	1	575	1	843	1
40	0	308	0	576	0	844	1
41	1	309	0	577	1	845	1
42	1	310	0	578	0	846	0
43	0	311	1	579	0	847	0
44	0	312	0	580	1	848	1
45	0	313	1	581	1	849	0
46	1	314	1	582	1	850	1
47	1	315	0	583	0	851	1

Table N.5—Chip sequence c_{PSDU} (continued)

Chip #	Chip value	Chip #	Chip value	Chip #	Chip value	Chip #	Chip value
48	1	316	0	584	1	852	0
49	0	317	0	585	0	853	0
50	1	318	1	586	0	854	0
51	1	319	1	587	1	855	1
52	0	320	0	588	1	856	0
53	0	321	1	589	1	857	1
54	0	322	0	590	0	858	1
55	1	323	0	591	0	859	0
56	0	324	1	592	0	860	0
57	1	325	1	593	1	861	0
58	1	326	1	594	0	862	1
59	0	327	0	595	0	863	1
60	0	328	1	596	1	864	0
61	0	329	0	597	1	865	1
62	1	330	0	598	1	866	0
63	1	331	1	599	0	867	0
64	0	332	1	600	0	868	1
65	1	333	1	601	1	869	1
66	0	334	0	602	1	870	1
67	0	335	0	603	0	871	0
68	1	336	1	604	0	872	1
69	1	337	0	605	0	873	0
70	1	338	1	606	1	874	0
71	0	339	1	607	1	875	1
72	0	340	0	608	1	876	1
73	1	341	0	609	0	877	1
74	1	342	0	610	1	878	0
75	0	343	1	611	1	879	0
76	0	344	1	612	0	880	0
77	0	345	0	613	0	881	1
78	1	346	0	614	0	882	0
79	1	347	1	615	1	883	0
80	1	348	1	616	1	884	1

Table N.5—Chip sequence c_{PSDU} (continued)

Chip #	Chip value	Chip #	Chip value	Chip #	Chip value	Chip #	Chip value
81	0	349	1	617	0	885	1
82	1	350	0	618	0	886	1
83	1	351	0	619	1	887	0
84	0	352	0	620	1	888	1
85	0	353	1	621	1	889	0
86	0	354	0	622	0	890	0
87	1	355	0	623	0	891	1
88	0	356	1	624	0	892	1
89	1	357	1	625	1	893	1
90	1	358	1	626	0	894	0
91	0	359	0	627	0	895	0
92	0	360	0	628	1	896	1
93	0	361	1	629	1	897	0
94	1	362	1	630	1	898	1
95	1	363	0	631	0	899	1
96	0	364	0	632	1	900	0
97	1	365	0	633	0	901	0
98	0	366	1	634	0	902	0
99	0	367	1	635	1	903	1
100	1	368	1	636	1	904	0
101	1	369	0	637	1	905	1
102	1	370	1	638	0	906	1
103	0	371	1	639	0	907	0
104	1	372	0	640	0	908	0
105	0	373	0	641	1	909	0
106	0	374	0	642	0	910	1
107	1	375	1	643	0	911	1
108	1	376	0	644	1	912	0
109	1	377	1	645	1	913	1
110	0	378	1	646	1	914	0
111	0	379	0	647	0	915	0
112	1	380	0	648	0	916	1
113	0	381	0	649	1	917	1

Table N.5—Chip sequence c_{PSDU} (continued)

Chip #	Chip value	Chip #	Chip value	Chip #	Chip value	Chip #	Chip value
114	1	382	1	650	1	918	1
115	1	383	1	651	0	919	0
116	0	384	0	652	0	920	1
117	0	385	1	653	0	921	0
118	0	386	0	654	1	922	0
119	1	387	0	655	1	923	1
120	1	388	1	656	1	924	1
121	0	389	1	657	0	925	1
122	0	390	1	658	1	926	0
123	1	391	0	659	1	927	0
124	1	392	1	660	0	928	1
125	1	393	0	661	0	929	0
126	0	394	0	662	0	930	1
127	0	395	1	663	1	931	1
128	1	396	1	664	0	932	0
129	0	397	1	665	1	933	0
130	1	398	0	666	1	934	0
131	1	399	0	667	0	935	1
132	0	400	1	668	0	936	0
133	0	401	0	669	0	937	1
134	0	402	1	670	1	938	1
135	1	403	1	671	1	939	0
136	0	404	0	672	0	940	0
137	1	405	0	673	1	941	0
138	1	406	0	674	0	942	1
139	0	407	1	675	0	943	1
140	0	408	0	676	1	944	1
141	0	409	1	677	1	945	0
142	1	410	1	678	1	946	1
143	1	411	0	679	0	947	1
144	1	412	0	680	0	948	0
145	0	413	0	681	1	949	0
146	1	414	1	682	1	950	0

Table N.5—Chip sequence c_{PSDU} (continued)

Chip #	Chip value	Chip #	Chip value	Chip #	Chip value	Chip #	Chip value
147	1	415	1	683	0	951	1
148	0	416	1	684	0	952	1
149	0	417	0	685	0	953	0
150	0	418	1	686	1	954	0
151	1	419	1	687	1	955	1
152	1	420	0	688	0	956	1
153	0	421	0	689	1	957	1
154	0	422	0	690	0	958	0
155	1	423	1	691	0	959	0
156	1	424	0	692	1	960	1
157	1	425	1	693	1	961	0
158	0	426	1	694	1	962	1
159	0	427	0	695	0	963	1
160	0	428	0	696	0	964	0
161	1	429	0	697	1	965	0
162	0	430	1	698	1	966	0
163	0	431	1	699	0	967	1
164	1	432	1	700	0	968	0
165	1	433	0	701	0	969	1
166	1	434	1	702	1	970	1
167	0	435	1	703	1	971	0
168	0	436	0	704	0	972	0
169	1	437	0	705	1	973	0
170	1	438	0	706	0	974	1
171	0	439	1	707	0	975	1
172	0	440	1	708	1	976	1
173	0	441	0	709	1	977	0
174	1	442	0	710	1	978	1
175	1	443	1	711	0	979	1
176	0	444	1	712	1	980	0
177	1	445	1	713	0	981	0
178	0	446	0	714	0	982	0
179	0	447	0	715	1	983	1

Table N.5—Chip sequence c_{PSDU} (continued)

Chip #	Chip value	Chip #	Chip value	Chip #	Chip value	Chip #	Chip value
180	1	448	0	716	1	984	1
181	1	449	1	717	1	985	0
182	1	450	0	718	0	986	0
183	0	451	0	719	0	987	1
184	1	452	1	720	0	988	1
185	0	453	1	721	1	989	1
186	0	454	1	722	0	990	0
187	1	455	0	723	0	991	0
188	1	456	1	724	1	992	1
189	1	457	0	725	1	993	0
190	0	458	0	726	1	994	1
191	0	459	1	727	0	995	1
192	1	460	1	728	0	996	0
193	0	461	1	729	1	997	0
194	1	462	0	730	1	998	0
195	1	463	0	731	0	999	1
196	0	464	0	732	0	1000	0
197	0	465	1	733	0	1001	1
198	0	466	0	734	1	1002	1
199	1	467	0	735	1	1003	0
200	0	468	1	736	0	1004	0
201	1	469	1	737	1	1005	0
202	1	470	1	738	0	1006	1
203	0	471	0	739	0	1007	1
204	0	472	1	740	1	1008	1
205	0	473	0	741	1	1009	0
206	1	474	0	742	1	1010	1
207	1	475	1	743	0	1011	1
208	0	476	1	744	0	1012	0
209	1	477	1	745	1	1013	0
210	0	478	0	746	1	1014	0
211	0	479	0	747	0	1015	1
212	1	480	1	748	0	1016	1

Table N.5—Chip sequence c_{PSDU} (continued)

Chip #	Chip value	Chip #	Chip value	Chip #	Chip value	Chip #	Chip value
213	1	481	0	749	0	1017	0
214	1	482	1	750	1	1018	0
215	0	483	1	751	1	1019	1
216	0	484	0	752	0	1020	1
217	1	485	0	753	1	1021	1
218	1	486	0	754	0	1022	0
219	0	487	1	755	0	1023	0
220	0	488	0	756	1	1024	0
221	0	489	1	757	1	1025	1
222	1	490	1	758	1	1026	0
223	1	491	0	759	0	1027	0
224	1	492	0	760	0	1028	1
225	0	493	0	761	1	1029	1
226	1	494	1	762	1	1030	1
227	1	495	1	763	0	1031	0
228	0	496	0	764	0	1032	0
229	0	497	1	765	0	1033	1
230	0	498	0	766	1	1034	1
231	1	499	0	767	1	1035	0
232	1	500	1	768	1	1036	0
233	0	501	1	769	0	1037	0
234	0	502	1	770	1	1038	1
235	1	503	0	771	1	1039	1
236	1	504	1	772	0	1040	1
237	1	505	0	773	0	1041	0
238	0	506	0	774	0	1042	1
239	0	507	1	775	1	1043	1
240	0	508	1	776	0	1044	0
241	1	509	1	777	1	1045	0
242	0	510	0	778	1	1046	0
243	0	511	0	779	0	1047	1
244	1	512	1	780	0	1048	0
245	1	513	0	781	0	1049	1

Table N.5—Chip sequence c_{PSDU} (continued)

Chip #	Chip value	Chip #	Chip value	Chip #	Chip value	Chip #	Chip value
246	1	514	1	782	1	1050	1
247	0	515	1	783	1	1051	0
248	0	516	0	784	0	1052	0
249	1	517	0	785	1	1053	0
250	1	518	0	786	0	1054	1
251	0	519	1	787	0	1055	1
252	0	520	0	788	1	1056	1
253	0	521	1	789	1	1057	0
254	1	522	1	790	1	1058	1
255	1	523	0	791	0	1059	1
256	1	524	0	792	0	1060	0
257	0	525	0	793	1	1061	0
258	1	526	1	794	1	1062	0
259	1	527	1	795	0	1063	1
260	0	528	0	796	0	1064	0
261	0	529	1	797	0	1065	1
262	0	530	0	798	1	1066	1
263	1	531	0	799	1	1067	0
264	1	532	1	800	0	1068	0
265	0	533	1	801	1	1069	0
266	0	534	1	802	0	1070	1
267	1	535	0	803	0	1071	1

Insert after new Annex N the following new annex (Annex O):

Annex O

(informative)

Example of encoding a packet for MR-FSK PHY

O.1 Introduction

This annex provides six examples of how the MR-FSK PHY would encode a sample PSDU received from the MAC sublayer. The list of examples with parameters is given in Table O.1. For additional examples, see “Examples of encoding a packet for the MR-FSK PHY– Part 1” [B22] and “Examples of encoding a packet for the MR-FSK PHY– Part 2” [B23]; the most recent versions of these documents should be referenced.

Table O.1—Encoding examples for MR-FSK PHY

Example	Modulation	Data whitening	FEC	Interleaving	<i>phyMRFSKSF</i> D	Subclause number
1	Filtered 2FSK	Disabled	Disabled	Disabled	0	O.2
2	Filtered 2FSK	Enabled	Disabled	Disabled	0	O.3
3	Filtered 2FSK	Enabled	RSC	Enabled	0	O.4
4	Filtered 2FSK	Disabled	NRNSC	Enabled	1	O.5
5	Filtered 4FSK	Disabled	Disabled	Disabled	1	O.6
6	Filtered 4FSK	Enabled	RSC	Enabled	0	O.7

In all examples, the message encoded is a PSDU that is 7 octets in length. The message constitutes an acknowledgment frame with a 3-octet MHR and a 4-octet FCS, as defined in 5.2.1.9. The bit sequence of the example PSDU is: 0100 0000 0000 0000 0101 0110 0101 1101 0010 1001 1111 1010 0010 1000.

The encoding illustration goes through the following stages:

- a) Generating the bit sequence of the SHR
- b) Generating the bit sequence of the PHR
- c) Concatenating the PHR, PSDU, and when FEC is enabled, tail bits and pad bits
- d) Encoding of the concatenated bit sequence with the specified FEC code when FEC is enabled
- e) Interleaving of the code-bit sequence when interleaving is enabled (requires FEC also enabled)
- f) Data whitening of the PSDU when data whitening is enabled
- g) Concatenation to form the PPDU

For each example, the settings of the PIB attributes are also shown.

O.2 Example 1

O.2.1 Settings

For this example, selected PIB attributes are set as follows:

- *phyFSKPreambleLength* = 4
- *phyMRFSKSFD* = 0
- *phyFSKFECEnabled* = FALSE
- *phyFSKFECScheme* = N/A
- *phyFSKScramblePSDU* = FALSE

O.2.2 Generation of the SHR

The bit sequence of the SHR, consisting of four preamble octets and two SFD octets, is given as:

0101 0101 0101 0101 0101 0101 0101 0101 1001 0000 0100 1110

O.2.3 Generation of the PHR

The Mode Switch (MS) field is set to zero (no mode switch), the reserved field entries are both set to zero, the FCS Type (FCS) field is set to zero corresponding to a 4-octet FCS, the Data Whitening (DW) field is set to zero (data whitening is not used), and the Frame Length field entries are set to the binary representation of “7,” corresponding to the PSDU length of the packet. The complete PHR field is shown in Figure O.1.

Bit string index	0	1–2	3	4	5–15
Bit mapping	MS	R ₁ –R ₀	FCS	DW	L ₁₀ –L ₀
Field name	Mode Switch	Reserved	FCS Type	Data Whitening	Frame Length
Value	0	00	0	0	00000000111

Figure O.1—PHR for the MR-FSK PHY packet when data whitening is disabled

O.2.4 Concatenating the SHR with the PHR and PSDU

The bit sequence for the PPDU is given as:

0101 0101 0101 0101 0101 0101 0101 0101 1001 0000 0100 1110 0000 0000 0000 0111 0100 0000 0000
0000 0101 0110 0101 1101 0010 1001 1111 1010 0010 1000

O.3 Example 2

O.3.1 Settings

For this example, selected PIB attributes are set as follows:

- *phyFSKPreambleLength* = 4
- *phyMRFSKSFD* = 0

- *phyFSKFECEnabled* = FALSE
- *phyFSKFECScheme* = N/A
- *phyFSKScramblePSDU* = TRUE

O.3.2 Generation of the SHR

The bit sequence of the SHR, consisting of four preamble octets and two SFD octets, is given as:

0101 0101 0101 0101 0101 0101 0101 0101 1001 0000 0100 1110

O.3.3 Generation of the PHR

The Mode Switch (MS) field is set to zero (no mode switch), the reserved field entries are both set to zero, the FCS Type (FCS) field is set to zero corresponding to a 4-octet FCS, the Data Whitening (DW) field is set to one (data whitening is used), and the Frame Length field entries are set to the binary representation of “7,” corresponding to the PSDU length of the packet. The complete PHR field is shown in Figure O.2.

Bit string index	0	1–2	3	4	5–15
Bit mapping	MS	R ₁ –R ₀	FCS	DW	L ₁₀ –L ₀
Field name	Mode Switch	Reserved	FCS Type	Data Whitening	Frame Length
Value	0	00	0	1	00000000111

Figure O.2—PHR for the MR-FSK PHY packet when data whitening is enabled

O.3.4 Bit sequence after data whitening of the PSDU and concatenation with PHR

Data whitening of the PSDU is performed as described in 18.1.3. The bit sequence of the PHR and PSDU after data whitening is given as:

0000 1000 0000 0111 0100 1111 0111 0000 1110 0101 0011 0010 0110 1010 0110 0010 0110 0000

O.3.5 Concatenating the SHR with the PHR and PSDU

The bit sequence for the PPDU is given as:

0101 0101 0101 0101 0101 0101 0101 0101 1001 0000 0100 1110 0000 1000 0000 0111 0100 1111 0111
0000 1110 0101 0011 0010 0110 1010 0110 0010 0110 0000

O.4 Example 3

O.4.1 Settings

For these examples, selected PIB attributes are set as follows:

- *phyFSKPreambleLength* = 4
- *phyMRFSKSFD* = 0

- *phyFSKFECEnabled* = TRUE
- *phyFSKFECScheme* = 1
- *phyFSKScramblePSDU* = TRUE
- *phyFSKFECInterleavingRSC* = TRUE

O.4.2 Generation of the SHR

The bit sequence of the SHR, consisting of four preamble octets and two SFD octets, is given as:

```
0101 0101 0101 0101 0101 0101 0101 0101 0110 1111 0100 1110
```

O.4.3 Generation of the PHR

The bit sequence of the PHR is generated as in Figure O.2 and is:

```
0000 1000 0000 0111
```

O.4.4 Concatenating the PHR, PSDU, tail bits, and pad bits

Concatenation of the PHR, PSDU, tail bits, and pad bits is performed as described in 18.1.2.4. After concatenation, the bit sequence is given as:

```
0000 1000 0000 0111 0100 0000 0000 0000 0101 0110 0101 1101 0010 1001 1111 1010 0010 1000 0100  
1011
```

O.4.5 Encoding of the bit sequence

Convolutional coding is performed as described in 18.1.2.4. The bit sequence after convolutional coding is given as:

```
0000 0000 1110 1000 0010 1000 0001 1111 0011 1010 0000 1010 0000 1010 0000 1010 0011 0011 1001  
0100 0001 0001 0101 0011 0000 1110 0110 1001 1101 0101 1110 1100 1010 1110 1100 1010 0011 0000  
1110 0101
```

O.4.6 Interleaving of the bit sequence

Interleaving is performed as described in 18.1.2.5. The bit sequence after interleaving is given as:

```
1100 0000 1110 1000 0110 1000 0000 1100 1010 1010 1010 1010 0000 0011 0000 0000 1101 0011 0000  
0100 0101 0111 0100 1000 0001 0110 1101 1011 1001 1000 1111 0100 0100 1010 0100 1011 1011 0010  
1100 1110
```

O.4.7 Bit sequence after data whitening of the PSDU

Data whitening of the PSDU is performed as described in 18.1.3. The bit sequence after data whitening is given as:

```
1100 0000 1110 1000 0110 1000 0000 1100 1010 0101 1101 1010 1011 0000 0110 1111 1001 0000 1001
1100 0001 1111 1110 0110 1010 1010 0100 1100 1010 0000 1110 1001 1001 1001 1001 1111 0001 0010
1001 1011
```

O.4.8 Concatenating the SHR with the PHR and PSDU

The bit sequence for the PPDU is given as:

```
0101 0101 0101 0101 0101 0101 0101 0101 0110 1111 0100 1110 1100 0000 1110 1000 0110 1000 0000
1100 1010 0101 1101 1010 1011 0000 0110 1111 1001 0000 1001 1100 0001 1111 1110 0110 1010 1010
0100 1100 1010 0000 1110 1001 1001 1001 1001 1111 0001 0010 1001 1011
```

O.5 Example 4

For this example, selected PIB attributes are set as follows:

- *phyFSKFECEnabled* = TRUE
- *phyFSKFECScheme* = 0
- *phyFSKScramblePSDU* = FALSE
- *phyMRFSKSFD* = 1

O.5.1 Generation of the SHR

The bit sequence of the SHR, consisting of four preamble octets and two SFD octets, is given as:

```
0101 0101 0101 0101 0101 0101 0101 0101 0110 0011 0010 1101
```

O.5.2 Generation of the PHR

The bit sequence of the PHR is generated as in Figure O.1 and is:

```
0000 0000 0000 0111
```

O.5.3 Concatenating the PHR, PSDU, tail bits, and pad bits

Concatenation of the PHR, PSDU, tail bits, and pad bits is performed as described in 18.1.2.4. After concatenation, the bit sequence is given as:

```
0000 0000 0000 0111 0100 0000 0000 0000 0101 0110 0101 1101 0010 1001 1111 1010 0010 1000 0000
1011
```

O.5.4 Encoding of the bit sequence

Convolutional coding is performed as described in 18.1.2.4. The bit sequence after convolutional coding is given as:

```
1111 1111 1111 1111 1111 1111 1100 0110 1000 0100 0011 1111 1111 1111 1111 1111 1100 1011 0111
1001 1111 1011 1010 1000 0100 1110 1101 0011 0110 0101 0110 0001 0000 0010 1101 0000 1111 1111
0010 1110
```

O.5.5 Interleaving of the bit sequence

Interleaving is performed as described in 18.1.2.5. The bit sequence after interleaving is given as:

```
1011 1111 0111 1111 0011 1111 1111 1111 1111 1100 1111 1101 1111 1100 1111 0010 0011 0111 1010
1010 1011 1100 1011 0111 0101 1110 0001 0011 1010 0100 0101 1101 1011 0010 1111 0000 1011 0100
0011 1100
```

O.5.6 Concatenating the SHR with the PHR and PSDU

The bit sequence for the PPDU is given as:

```
0101 0101 0101 0101 0101 0101 0101 0101 0110 0011 0010 1101 1011 1111 0111 1111 0011 1111 1111
1111 1111 1100 1111 1101 1111 1100 1111 0010 0011 0111 1010 1010 1011 1100 1011 0111 0101 1110
0001 0011 1010 0100 0101 1101 1011 0010 1111 0000 1011 0100 0011 1100
```

O.6 Example 5

For this example, selected PIB attributes are set as follows:

- *phyFSKFECEnabled* = FALSE
- *phyFSKFECScheme* = 0
- *phyFSKScramblePSDU* = FALSE
- *phyMRFSKSFD* = 1

O.6.1 Generation of the SHR

The preamble consists of *phyFSKPreambleLength* (which is four in these examples) multiples of the 16-bit sequence:

```
0111 0111 0111 0111
```

The SFD bit sequence is:

```
0111 1111 1101 1101 0101 0101 1111 1101
```

The bit sequence of the SHR is given as:

```
0111 0111 0111 0111 0111 0111 0111 0111 0111 0111 0111 0111 0111 0111 0111 0111 0111 1111 1101
1101 0101 0101 1111 1101
```

O.6.2 Generation of the PHR

The bit sequence of the PHR is generated as in Figure O.1 and is:

```
0000 0000 0000 0111
```

O.6.3 Generation of the PSDU

The bit sequence of the PSDU is:

```
0100 0000 0000 0000 0101 0110 0101 1101 0010 1001 1111 1010 0010 1000
```

O.6.4 Concatenating the SHR with the PHR and PSDU

The bit sequence for the PPDU is given as:

```
0111 0111 0111 0111 0111 0111 0111 0111 0111 0111 0111 0111 0111 0111 0111 0111 0111 0111 1111 1101  
1101 0101 0101 1111 1101 0000 0000 0000 0111 0100 0000 0000 0000 0101 0110 0101 1101 0010 1001  
1111 1010 0010 1000
```

O.7 Example 6

O.7.1 Settings

For this example, selected PIB attributes are set as follows:

- *phyFSKPreambleLength* = 4
- *phyMRFSKSFD* = 0
- *phyFSKFECEnabled* = TRUE
- *phyFSKFECScheme* = 1
- *phyFSKScramblePSDU* = TRUE
- *phyFSKFECInterleavingRSC* = TRUE

O.7.2 Generation of the SHR

The bit sequence of the SHR, consisting of eight preamble octets and four SFD octets, is given as:

```
0111 0111 0111 0111 0111 0111 0111 0111 0111 0111 0111 0111 0111 0111 0111 0111 1101 1111  
1111 0111 0101 1111 1101
```

O.7.3 Generation of the PHR

The bit sequence of the PHR is generated as in Figure O.2 and is:

```
0000 1000 0000 0111
```

O.7.4 Concatenating the PHR, PSDU, tail bits, and pad bits

Concatenation of the PHR, PSDU, tail bits, and pad bits is performed as described in 18.1.2.4. After concatenation, the bit sequence is given as:

```
0000 1000 0000 0111 0100 0000 0000 0000 0101 0110 0101 1101 0010 1001 1111 1010 0010 1000 0100  
1011
```

O.7.5 Encoding of the bit sequence

Convolutional coding is performed as described in 18.1.2.4. The bit sequence after convolutional coding is given as:

```
0000 0000 1110 1000 0010 1000 0001 1111 0011 1010 0000 1010 0000 1010 0000 1010 0011 0011 1001  
0100 0001 0001 0101 0011 0000 1110 0110 1001 1101 0101 1110 1100 1010 1110 1100 1010 0011 0000  
1110 0101
```

O.7.6 Interleaving of the bit sequence

Interleaving is performed as described in 18.1.2.5. The bit sequence after interleaving is given as:

```
1100 0000 1110 1000 0110 1000 0000 1100 1010 1010 1010 1010 0000 0011 0000 0000 1101 0011 0000  
0100 0101 0111 0100 1000 0001 0110 1101 1011 1001 1000 1111 0100 0100 1010 0100 1011 1011 0010  
1100 1110
```

O.7.7 Bit sequence after data whitening of the PSDU

Data whitening of the PSDU is performed as described in 18.1.3. The bit sequence after data whitening is given as:

```
1100 0000 1110 1000 0110 1000 0000 1100 1010 0101 1101 1010 1011 0000 0110 1111 1001 0000 1001  
1100 0001 1111 1110 0110 1010 1010 0100 1100 1010 0000 1110 1001 1001 1001 1001 1111 0001 0010  
1001 1011
```

O.7.8 Concatenating the SHR with the PHR and PSDU

The bit sequence for the PPDU is given as:

```
0111 0111 0111 0111 0111 0111 0111 0111 0111 0111 0111 0111 0111 0111 0111 0111 0111 0111 1101 1111  
1111 0111 0101 1111 1101 1100 0000 1110 1000 0110 1000 0000 1100 1010 0101 1101 1010 1011 0000  
0110 1111 1001 0000 1001 1100 0001 1111 1110 0110 1010 1010 0100 1100 1010 0000 1110 1001 1001  
1001 1001 1111 0001 0010 1001 1011
```