

PVC Network-to-Network Interface (NNI) Implementation Agreement

FRF.2.2

**Frame Relay Forum Technical Committee
March 2002**

Note: The user's attention is called to the possibility that implementation of the frame relay implementation agreement contained herein may require the use of inventions covered by patent rights held by third parties. By publication of this frame relay implementation agreement the Frame Relay Forum makes no representation that the implementation of the specification will not infringe on any third party rights. The Frame Relay Forum take no position with respect to any claim that has been or may be asserted by any third party, the validity of any patent rights related to any such claims, or the extent to which a license to use any such rights may not be available.

Editors:

Claude Kawa
Nortel Networks
David Sinicrope
Formerly with Lucent Technologies

For more information contact:

The Frame Relay Forum

Suite 307
39355 California Street
Fremont, CA 94538 USA

Phone: +1 (510) 608-5920
FAX: +1 (510) 608-5917
E-Mail: frf@frforum.com
WWW: <http://www.frforum.com>

Copyright © Frame Relay Forum 2002. All Rights Reserved.

This document and translations of it may be copied and furnished to others, and works that comment on or otherwise explain it or assist in its implementation may be prepared, copied, published and distributed, in whole or in part, without restriction of any kind, provided that the above copyright notice and this paragraph are included on all such copies and derivative works. However, this document itself may not be modified in any way, such as by removing the copyright notice or references to the Frame Relay Forum, except as needed for the purpose of developing Frame Relay standards (in which case the procedures for copyrights defined by the Frame Relay Forum must be followed), or as required to translate it into languages other than English.

This document and the information contained herein is provided on an "AS IS" basis and THE FRAME RELAY FORUM DISCLAIMS ALL WARRANTIES, EXPRESS OR IMPLIED, INCLUDING BUT NOT LIMITED TO ANY WARRANTY THAT THE USE OF THE INFORMATION HEREIN WILL NOT INFRINGE ANY RIGHTS OR ANY IMPLIED WARRANTIES OF MERCHANTABILITY OR FITNESS FOR A PARTICULAR PURPOSE.

Table of Contents

1	INTRODUCTION	5
1.1	PURPOSE	5
1.2	DEFINITIONS.....	5
1.3	ACRONYM LIST	6
1.4	RELEVANT STANDARDS.....	6
2	IMPLEMENTATION AGREEMENTS	6
2.1	PHYSICAL LAYER INTERFACE GUIDELINES	6
2.1.1	Data Transfer	6
2.1.2	Interframe Time Fill	7
2.1.3	Frame Relay Information Field (Q.922 Annex A §A.2.5 & §A.5.1).....	7
2.1.4	Address Field Variables.....	7
2.2	CONGESTION MANAGEMENT.....	7
2.2.1	Consolidated Link Layer Management (CLLM) Message (Q.922 Annex A §A.7)	8
2.3	CONTROL (SIGNALLING) PROCEDURES.....	8
2.3.1	Permanent Virtual Connection (PVC) Procedures	8
2.3.2	Switched Virtual Connection (SVC) Procedures	8
2.4	NETWORK PERFORMANCE PARAMETERS	8
2.4.1	PVC Parameter Coordination.....	9
3	APPLICATION OF BIDIRECTIONAL PROCEDURES FOR USE AT THE NNI	9
3.1	BIDIRECTIONAL NETWORK PROCEDURES AND MULTI-NETWORK PVCs.....	9
3.2	POLLING REQUIREMENTS OF NETWORK-TO-NETWORK INTERFACES.....	11
3.3	INITIAL NNI STATUS	12
3.4	MULTI-NETWORK PVC ACTIVE STATUS CRITERIA	13
3.5	ADDING A MULTI-NETWORK PVC	13
3.6	DELETING A MULTI-NETWORK PVC	13
3.7	RESPONSE TO UNI FAILURE	14
3.8	RESPONSE TO PVC SEGMENT FAILURE	14
3.9	RESPONSE TO NNI FAILURE.....	14
3.10	EXAMPLES OF MULTI-NETWORK PVC STATUS SIGNALLING	14
3.10.1	Generic example comments.....	14
3.10.2	Nomenclature.....	15
3.10.3	Example of adding a multi-network PVC.....	16
3.10.4	Example of deleting a multi-network PVC.....	17
3.10.5	Example of UNI failure and restoration.....	18
3.10.6	Example of PVC segment failure and restoration	20
3.10.7	Example of NNI failure and restoration.....	20
	APPENDIX 1: HANDLING OF PHYSICAL LAYER LOOPBACK CONDITIONS WHEN USING FRAME RELAY PVC BI-DIRECTIONAL PROCEDURES	22

List of Tables

Table 1 NNI system parameters.....12

List of Figures

Figure 1 Multi-network PVC.....10
Figure 2 NNI bi-directional procedures.....11
Figure 3 Example Multi-network PVC.....15
Figure 4 Configuration of a multi-network PVC.....17
Figure 5 Deletion of a multi-network PVC.....18
Figure 6 UNI failure and restoration.....19
Figure 7 PVC segment failure and restoration.....20
Figure 8 NNI failure and restoration.....21

Revision History

Version	Change	Date
FRF.2	First release of NNI Implementation Agreement FRF.2	August 26, 1992
FRF.2.1	Second release of NNI Implementation Agreement FRF.2.1. Modified to include high speed interfaces, optional 4 octet DLCIs, international standards are referenced wherever possible, informative Appendix describing loop detect procedures, and normative Annex describing optional event driven procedures to provide many more PVCs per interface, faster reporting of status changes and failure cause information	July 10, 1995
FRF.2.2	Third release of NNI Implementation Agreement FRF.2.2. Modified to include: <ul style="list-style-type: none"> - replacement of Physical Layer Interface Guidelines with reference to Physical Layer Interface Implementation Agreement - updated with consistent Address Field Variable section for consistent wording throughout the implementation agreements. Alignment of DLCI ranges for backward compatibility between 2 and 4 octet address formats - enhanced LMI for large scale NNIs - removal of the event driven procedures 	January 15, 2002

This Page Left Blank Intentionally

1 Introduction

1.1 Purpose

This document is a frame relay permanent virtual connection (PVC) Network-to-Network Interface (NNI) implementation agreement. The agreements herein were reached in the Frame Relay Forum, and are based on the relevant frame relay standards referenced in Section 1.3. They address the optional parts of these standards, and document agreements reached among vendors/suppliers of frame relay network products and services regarding the options to be implemented.

The default NNI PVC management procedures are as defined in Q.933 Annex A bidirectional procedures. Refer to Section 3.0, Application of Bidirectional Procedures for Use at the Network-to-Network Interface, of this implementation agreement.

Except as noted, these agreements will form the basis of conformance test suites produced by the Frame Relay Forum.

This document may be submitted to different bodies involved in ratification of implementation agreements and conformance testing to facilitate multi-vendor interoperability.

1.2 Definitions

Must, Shall, or Mandatory — the item is an absolute requirement of the implementation agreement.

Should — the item is highly desirable.

May or Optional — the item is not compulsory and may be followed or ignored according to the needs of the implementor.

- Network-to-Network Interface (NNI) - the Network-to-Network Interface is concerned with the transfer of C-Plane and U-Plane information between two network nodes belonging to two different frame relay networks.
- Must, Shall, or Mandatory - the item is an absolute requirement of this implementation agreement.
- Should - the item is highly desirable.
- May or Optional - the item is not compulsory, and may be followed or ignored according to the needs of the implementor.
- Not Applicable - the item is outside the scope of this implementation agreement.
- PVC segment - A PVC in a single network that is a component of a multi-network PVC.
- Multi-network PVC - A concatenation of two or more PVC segments.

1.3 Acronym List

DLCI	Data Link Connection Identifier
NNI	Network-to-Network Interface
PVC	Permanent Virtual Circuit
UNI	User-Network-INterface

1.4 Relevant Standards

The following is a list of standards and implementation agreements on which this frame relay NNI implementation agreement is based:

1. CCITT Recommendation I.233.1 - Frame Relay Bearer Services, 1991.
2. CCITT Recommendation I.370 - Congestion Management for the ISDN Frame Relaying Bearer Service, 1991.
3. ITU-T Recommendation I.372 - Frame Relaying Bearer Service Network-to-Network Interface Requirements, 1993.
4. CCITT Recommendation Q.922 - ISDN Data Link Layer Specification for Frame Mode Bearer Services, 1992.
5. ITU-T Implementor's Guide for Recommendation Q.922, December 2000.
6. ITU-T Recommendation E.164 / I.331 – The International Public Telecommunication Numbering Plan, 1997.
7. ITU-T Recommendation X.121 - International Numbering Plan for Public Data Networks, 1996.
8. ITU-T Recommendation Q.933 - ISDN Digital Subscriber Signalling System No. 1 (DSS 1) - Signalling Specifications for Frame Mode Switched and Permanent Virtual Connection Control and Status Monitoring, 1995.
9. ITU-T I.555 - Frame Relaying Bearer Service Interworking, 1997.
10. Frame Relay Forum Implementation Agreement FRF.1.2 - Frame Relay User-to-Network Implementation Agreement, 2000.
11. Frame Relay Forum Implementation Agreement FRF.5 - Frame Relay/ATM Network Interworking Implementation Agreement, 1994.
12. Frame Relay Forum Implementation Agreement FRF.14 - Physical Layer Interface Implementation Agreement, 1999.

2 Implementation Agreements

2.1 Physical Layer Interface Guidelines

The recommended physical layer Network-to-Networks Interfaces (NNIs) are listed in [11].

2.1.1 Data Transfer

This section is intended to be used for Frame Relay conformance testing. Implementations for the Frame Relay NNI U-plane shall be based on CCITT Q.922 Annex A. Implementation agreements on the optional parts of Q.922 Annex A are as follows:

2.1.2 Interframe Time Fill

Interframe time fill shall be accomplished by transmitting one or more contiguous HDLC flags with the bit pattern 01111110 when the data link layer has no frames to send. All equipment shall be able to receive, as a minimum, consecutive frames separated by 1 flag.

2.1.3 Frame Relay Information Field (Q.922 Annex A §A.2.5 & §A.5.1)

A maximum frame relay information field size of 1600 octets shall be supported by networks. In addition, maximum information field sizes less than or greater than 1600 octets may be agreed to between networks by bilateral agreement during PVC provisioning.

2.1.4 Address Field Variables

- Note: On a given NNI, the address field and DLCI described below shall be configured as either 2 octets or 4 octets but not both.
- Length of Address Field (Q.922 Annex A §A.3.3.1)
- An address field of 2 octets shall be supported as the default. All frames using an address field of 2 octets must have the EA bit set to 0 in the first octet of the address field and the EA bit set to 1 in the second octet of the address field.
- The 3 octet address format is outside the scope of this implementation agreement.
- An address field of 4 octets may optionally be supported. All frames using an address field of 4 octets must have the EA bit set to 0 in the first, second and third octet of the address field and the EA bit set to 1 in the fourth octet of the address field.
- Data Link Connection Identifier (DLCI) (Q.922 Annex A §A.3.3.6):
- The 2 octet address format shall be supported with DLCI values as defined in Table 1 (for 10 bit DLCIs) of Q.922.
- The 4 octet address format may optionally be supported with DLCI values as defined in Table 1 of Q.922 and the Implementor's Guide to Q.922 [4, 5], except that the range 1-15 is reserved rather than 1-131071, and virtual circuit identification begins at DLCI 16. The 17 bit DLCI format with DL-CORE control is not supported.
- DLCI on the D-channel (Q.922 Annex A §A.3.3.6): The descriptions in Q.922 Table 1 and §3.3.6 related to DLCI assignment on the D-channel are not applicable to PVCs.
- DLCI or DL-CORE Control Indicator (D/C) (Q.922 Annex A §A.3.3.7): This section is applicable to an address field of 4 octets. This implementation agreement does not use the DL-CORE control (D/C bit set to 1).

Note: Other address structure variables (i.e., the command/response (C/R), discard eligibility indicator (DE), forward explicit congestion notification (FECN), and backward explicit congestion notification (BECN) bits) and their usage are as specified in Q.922 Annex A.

2.2 Congestion Management

Congestion management and control is described in CCITT I.370. The mandatory procedures of this recommendation shall be implemented.

Additional congestion management principles applicable to the NNI are as follows:

- Each network should generate forward explicit congestion notification (FECN), backward explicit congestion notification (BECN), and support rate enforcement using the DE indicator in accordance with CCITT I.370.
- Each Network is responsible for protecting itself against congestion scenarios at the network-to- Network Interface (e.g., a given network should not rely solely on the prior network's setting of the DE bit).
- Under normal operating conditions, every effort should be made not to discard Bc committed data at the NNI. One method to assure this, is to limit the sum of the subscribed CIRs (egress from the network) of all PVCs on a given NNI to be less than the NNI access rate.
- The committed information rate (CIR), committed burst size (Bc), and excess burst size (Be) values are administratively coordinated at the NNI. To provide a consistent service along the multi-network PVC, the same CIR value should be configured on all PVC segments (see Section 3.1 for definitions of multi-network PVC and PVC segment). CIR, Bc, and Be may be uniquely defined in both the forward and backward directions.
- The access rate (AR) of all NNIs involved in a multi-network PVC do not have to be equal. The access rate at one NNI may be substantially higher than at another NNI. Therefore, continuous input of Be frames at one NNI may lead to persistent congestion of the network buffers at another NNI, and a substantial amount of the input Be data may be discarded.

The relationships of CIR, Bc and Be are illustrated in Table 1/I.372. These constraints shall apply to selection of parameters at the NNI.

2.2.1 Consolidated Link Layer Management (CLLM) Message (Q.922 Annex A §A.7)

Use of the CLLM message is outside the scope of this implementation agreement.

2.3 Control (Signalling) Procedures

2.3.1 Permanent Virtual Connection (PVC) Procedures

The default NNI PVC management procedures are as defined in Q.933 Annex A bidirectional procedures. In addition, the segmentation of the PVC STATUS message defined in [10] is optional at the NNI. If used at the NNI both sides can segment the PVC STATUS message.

Refer to Section 3.0, Application of Bidirectional Procedures for Use at the NNI, of this implementation agreement.

2.3.2 Switched Virtual Connection (SVC) Procedures

Procedures for SVCs are not applicable to this implementation agreement.

2.4 Network Performance Parameters

Frame relay quality of service refers to service performance from the end-user standpoint. Network performance, when considered between two User-to-Network Interfaces, is closely tied to, and directly impacts the quality of service. Network performance parameters apply at different interfaces in the network. For a multi-network frame relay service, the values of performance parameters at the NNI contribute to the service performance from the end-user standpoint.

The performance parameters applicable to frame relay network-to-network service include those specified in Annex A of CCITT Recommendation I.233.1.

2.4.1 PVC Parameter Coordination

The parameter values that shall be administratively coordinated at the NNI include maximum frame size per PVC segment, originating DLCI and terminating DLCI of a PVC segment, and CIR in each direction per PVC segment. Additional parameters that should be coordinated include Bc and Be in each direction per PVC segment.

3 Application of Bidirectional Procedures for Use at the NNI

This section defines the unique NNI and User-to-Network Interactions when the bidirectional procedures are implemented at the NNI. Specific scenarios of how the PVC status information element status bits shall be interpreted in a multi-network environment are described. These scenarios include:

- addition of a multi-network PVC
- deletion of a multi-network PVC
- failure and restoration of a multi-network PVC

3.1 Bidirectional network procedures and multi-network PVCs

- When a permanent virtual connection (PVC) between two users involves more than one network, the portion of the PVC provided by each Network is termed a "PVC segment". A multi-network PVC is a concatenation of two or more PVC segments. This is depicted in Figure 1.

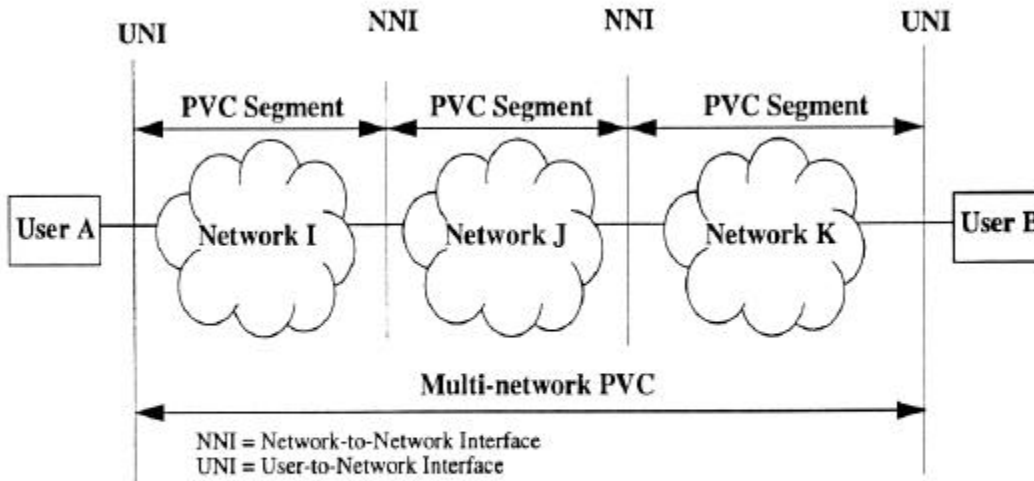

Figure 1
Multi-network PVC

The bidirectional network procedures shall be used to communicate status between networks. Each network at the NNI shall support both user side procedures and network side procedures simultaneously. In effect, there are two distinct user-to-network procedures taking place where each side of the NNI supports both user side and network side procedures concurrently. This is depicted in Figure 2.

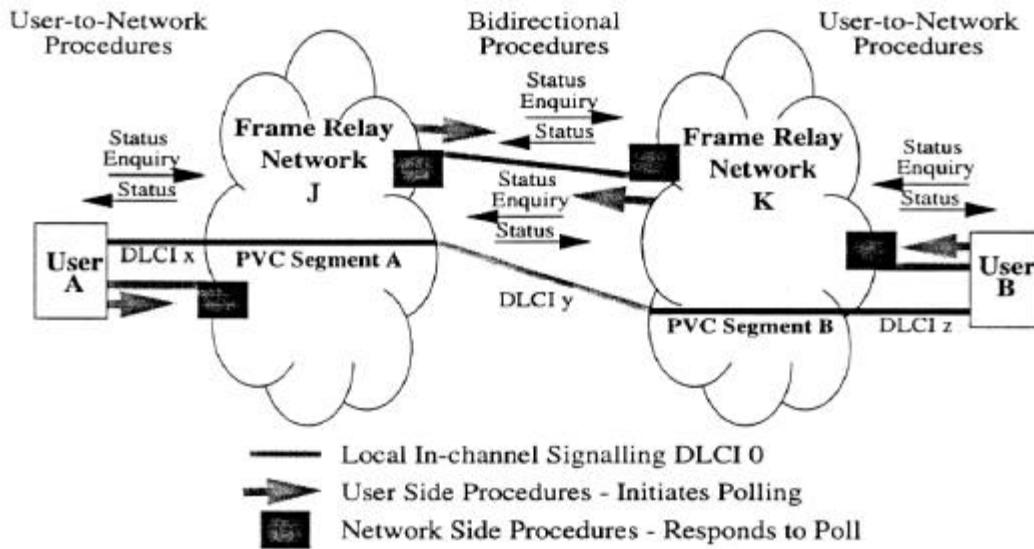

Figure 2
NNI Bidirectional Procedures

3.2 Polling requirements of network-to-network interfaces

Two sets of sequence numbers and local in-channel signalling parameters are administered for the NNI as shown below; see Table 1 for parameter ranges and default values.

- user side procedures - T391, N391, N392, and N393
- network side procedures - T392, N392, and N393

Table 1 summarizes the acceptable values when using bidirectional procedures at the NNI. The default values in Table 1 should be used as the actual system parameter values. Parameter values other than the default values may be selected by bilateral agreements between network operators. Procedures for starting and stopping T391 and T392 are described in Q.933 Annex A.

Name	Range	Default	Units	Definition
N391	1-255	6	Polling Cycles	Full status (status of all PVCs) polling cycles.
N392	1-10 ¹	3	Errors	Number of errors during N393 monitored events which cause the channel/user side procedures to be declared inactive. This number may also be used by the user side procedures as the number of errors during N393 monitored events which cause the network side procedures to be declared inactive.
N393	1-10 ²	4	Events	Monitored events count.
T391	5-30	10	Seconds	Link integrity verification polling timer.
T392	5-30 ³	15	Seconds	Timer for verification of polling cycle.

¹N392 should be less than or equal to N393.

²If N393 is set to a value much less than N391, then the link could go in and out of an error condition without the user side procedures or network side procedures being notified.

³T392 should be set greater than T391.

Table 1 - NNI system parameters

Both networks are required to initiate status enquiry messages based on T391. A full status report is requested each N391 (default 6) polling cycles. Both networks shall have the same values for T391, T392, N392, and N393 for both user side procedures and network side procedures; N391 is not required to have the same value in both networks.

PVC status information from full status reports and optionally from single PVC asynchronous status reports shall be propagated towards the user-to-network Interface (UNI) of the multi-network PVC. The PVC status information element active bit state signaled at the NNI is independent of the PVC status information element active bit state signaled in the other direction at the same NNI.

In addition, when a PVC segment's active/inactive status has changed, or a PVC segment has been newly added or deleted, the network should respond to any poll (i.e., status enquiry) with a full status report. Alternatively, the network may generate a single PVC asynchronous status report to convey the PVC segment's status change.

3.3 Initial NNI status

The NNI access channel shall be considered non-operational when the user side procedures or network side procedures are first activated.

- The NNI access channel should be considered non-operational until N393 consecutive valid polling cycles occur.
- As an alternative, if the first polling cycle constitutes a valid exchange of sequence numbers, then the respective NNI access channel shall be considered operational. If the first polling cycle results in an error, then the respective NNI shall be considered non-operational until N393 consecutive valid polling cycles occur.

3.4 Multi-network PVC active status criteria

The network shall report a multi-network PVC as “active” (i.e., active bit =1) at the UNI only if all the following criteria are met:

1. All PVC segments are configured.
2. Link integrity verification is successful at all UNIs and NNIs that are associated with the multi-network PVC (N393 consecutive valid polling cycles, or as defined in Section 4.3 above).
3. All UNIs and NNIs associated with the multi-network PVC are operational (i.e., no service affecting conditions).
4. All PVC segments within the multi-network PVC are operational (i.e., no service affecting conditions).
5. The remote user equipment, when supporting bidirectional procedures at the UNI, reports that the PVC is active by setting the active bit = 1 in a PVC status information element.

Whenever these criteria are not fully met, the active bit indication propagated toward the UNIs shall be set to 0.

Only a network with a PVC terminating at a UNI may set the active bit to 1 towards the remote UNI (considered the “target UNI”). Each succeeding network along the multi-network PVC may either pass the active bit unchanged or set the active bit to 0. If any PVC segment is not active along the multi-network PVC, an inactive status is propagated (when possible) to the target UNI.

See Sections 3.5 - 3.10 for further details.

3.5 Adding a multi-network PVC

Since a multi-network PVC consists of a number of PVC segments, each managed by a different network, all PVC segments in a multi-network PVC cannot be added simultaneously. The PVCs can be thought as being added one at a time in an arbitrary order.

The presence or absence of a PVC status information element in a full status report at either the User-to-Network Interface or at the NNI indicates only the presence or absence of a particular PVC segment within the multi-network PVC.

As each PVC segment is added to a multi-network PVC, the NNI(s) and the user device (if applicable) are notified that the PVC segment has been added (i.e., new bit set to 1). The active status in a multi-network PVC is set according to the criteria given in Section 4.4 and propagated towards the target UNI.

See Section 3.10.3 for an example of adding a multi-network PVC.

3.6 Deleting a multi-network PVC

Since a multi-network PVC consists of a number of concatenated PVC segments each managed by a different network, the PVC segments in a multi-network PVC cannot be deleted simultaneously. The PVC segments can be thought of as being deleted one at a time in an arbitrary order.

A multi-network PVC is considered to be deleted when the PVC status information element in the full status report has been deleted at every associated UNI and NNI.

The presence or absence of the PVC status information element at either the User-to-Network Interface or the NNI indicates only the presence or absence of a particular PVC segment within the multi-network PVC. As a PVC segment is deleted from a multi-network PVC, the adjacent network-to- Network Interface(s) and/or adjacent user

device (if applicable) are notified by the deletion of the PVC status information element that its associated PVC segment has been deleted.

An inactive status is propagated towards the target UNI whenever the deletion of a PVC segment is detected at the NNI.

See Section 3.10.4 for an example of deleting a multi-network PVC.

3.7 Response to UNI failure

When a network detects that the User-to-Network Interface is inoperative, it notifies users of the multi-network PVCs associated with the failed UNI that the multi-network PVCs are inactive. The PVC status changes are propagated through the adjacent network(s) to the remote users.

See Section 3.10.5 for an example of response to UNI failure.

3.8 Response to PVC segment failure

When a network determines that a PVC segment has become inoperative, it notifies the adjacent network(s) and/or UNI that the multi-network PVC is inactive. The PVC status change is propagated through the adjacent network(s) to the remote user(s).

See Section 3.10.6 for an example of PVC segment failure.

3.9 Response to NNI failure

When a network detects that a NNI is inoperative, each network notifies users of the PVCs associated with the NNI that the multi-network PVCs are inactive. The PVC status changes are propagated through the adjacent network(s) to the remote users.

See Section 3.10.7 for an example of response to NNI failure.

3.10 Examples of multi-network PVC status signalling

This section provides examples of multi-network permanent virtual connection (PVC) status signalling at the User-to-Network Interface (UNI) and NNI (NNI). It contains examples of multi-network PVC status signalling in the following scenarios:

- adding a multi-network PVC (See Section 3.10.3)
- deleting a multi-network PVC (See Section 3.10.4)
- UNI failure & restoration (See Section 3.10.5)
- PVC segment failure & restoration (See Section 3.10.6)
- NNI failure & restoration (See Section 3.10.7)

3.10.1 Generic example comments

Status enquiry/status report exchanges occur at all UNIs and NNIs to indicate that the interface is operational. The status enquiry/status report exchanges are shown only when a change in link integrity verification state occurs or when multi-network PVC status signalling is affected. The PVC status information elements are only shown when the associated PVC segment has a status change.

The flows throughout this section show only the use of full status reports to signal a change in multi-network PVCs. Alternatively, the single PVC asynchronous status reports may be used to convey multi-network PVC active and inactive status changes.

All examples deal with the following multi-network PVC consisting of two PVC segments as illustrated in Figure 3:

- PVC segment in Network I interfaces to User A with DLCI 16 and Network J with DLCI 32.
- PVC segment in Network J interfaces to Network I with DLCI 32 and User B with DLCI 48.

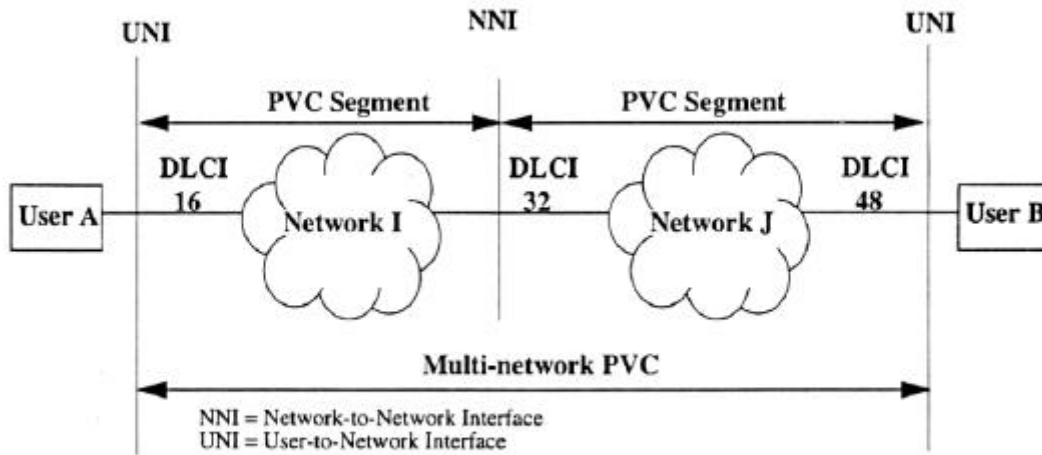

Figure 3
Example Multi-network PVC

Note that the default values of 3 errors for N392 and 4 monitored events for N393 are used throughout the examples.

3.10.2 Nomenclature

Notation	Meaning
SE	This is the status enquiry message as described in Q.933 Annex A, Section A.1.2. The request for a full status report need not be present.
S	This is the link integrity verification status report as described in Q.933 Annex A, Section A.1.1.
FS(16,N,I)	This is a full status report as described in Q.933 Annex A, Section A.1.1. A full status report request is not necessary for a full status report response. In this case, DLCI 16 reported the status of “new” and “inactive” for the PVC segment.
FS()	This is a full status report as described in Q.933 Annex A, Section A.1.1. A full status report request is not necessary for a full status report response. In this case, the PVC segment of interest is not present (e.g., no longer configured).

I->J	This indicates the status generated by Network I as seen by Network J.
A ₁₆ -I-J ₃₂	This designates a PVC segment from User A through Network I to Network J. At the User A to Network I UNI, DLCI 16 is used. At the Network I to Network J NNI, DLCI 32 is used.
C	The “C” status for a particular PVC segment indicates that the PVC is configured and the PVC status information element is present in the full status report.
Not C	The “Not C” status for a particular PVC segment indicates that the PVC is not configured and the PVC status information element is not present in the full status report.
N	The “N” status for a particular PVC segment indicates that the “new” bit is set to 1 in the PVC status information element at the indicated interface. (The absence of an “N” in the diagrams indicates that the “new” bit is set to 0.)
A	The “A” status for a particular PVC segment indicates that the “active” bit is set to 1 in the PVC status information element at the indicated interface.
I	The “I” status for a particular PVC segment indicates that the “active” bit is set to 0 in the PVC status information element at the indicated interface.
ChanI	The “ChanI” indicates that the channel is inactive at the UNI or NNI due to link integrity verification failure, or other network determined UNI or NNI service affecting condition (e.g., data set signals down).

3.10.3 Example of adding a multi-network PVC

When configuring a multi-network PVC, each PVC segment must be added through its associated network management system. Figure 4 shows the addition of the multi-network PVC:

- Network I to User A using DLCI 16
- Network I to Network J using DLCI 32
- Network J to User B using DLCI 48

Simultaneous configuration of both PVC segments in the multi-network PVC is virtually impossible. After the PVC segment is configured in Network I and before the PVC segment in Network J is configured, Network I may detect that the PVC segment in Network J is not present and informs User A with a full status report indicating that the PVC segment is inactive. Note that the PVC segment has been configured locally and is therefore present (on the user interface to User A) but inactive because it is not configured on the remote network (Network J). As far as User B is concerned, the entire multi-network PVC has not been configured until the PVC segment is configured on its local network (Network J).

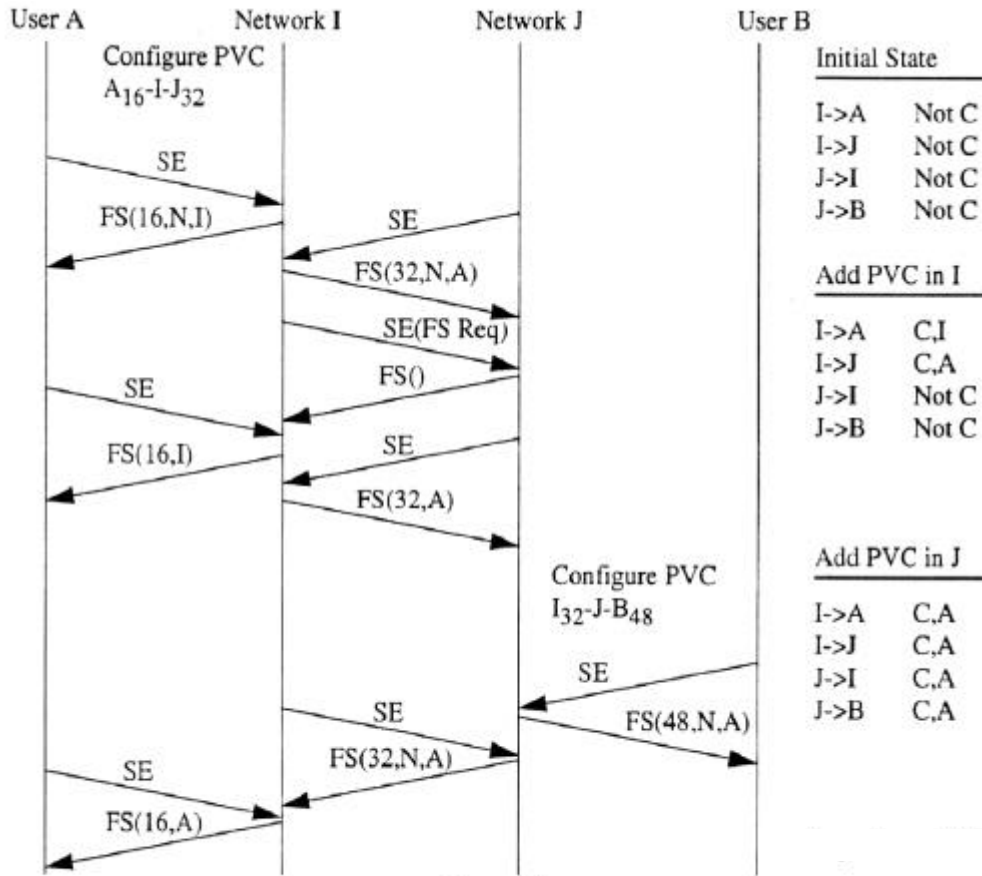

Figure 4
Configuration of a multi-network PVC

3.10.4 Example of deleting a multi-network PVC

When deleting a multi-network PVC, each PVC segment must be deleted through its associated network management system. Figure 5 shows the deletion of the multi-network PVC:

- Network I to User A using DLCI 16
- Network I to Network J using DLCI 32
- Network J to User B using DLCI 48

Simultaneous deletion of both PVC segments in the multi-network PVC is virtually impossible. User A receives a full status report with DLCI 16 deleted (absent) from Network I. After the PVC segment is deleted in Network I and before the PVC segment in Network J is deleted, Network J detects that the PVC segment in Network I is not present and informs User B with a full status report indicating that the PVC segment is inactive. Note that the PVC segment on Network J has not been deleted locally and is therefore present (on the user interface to User B) but

inactive because it is not configured on the remote network (Network I). As far as User B is concerned, the multi-network PVC is not deleted until the PVC segment is deleted on its local network (Network J).

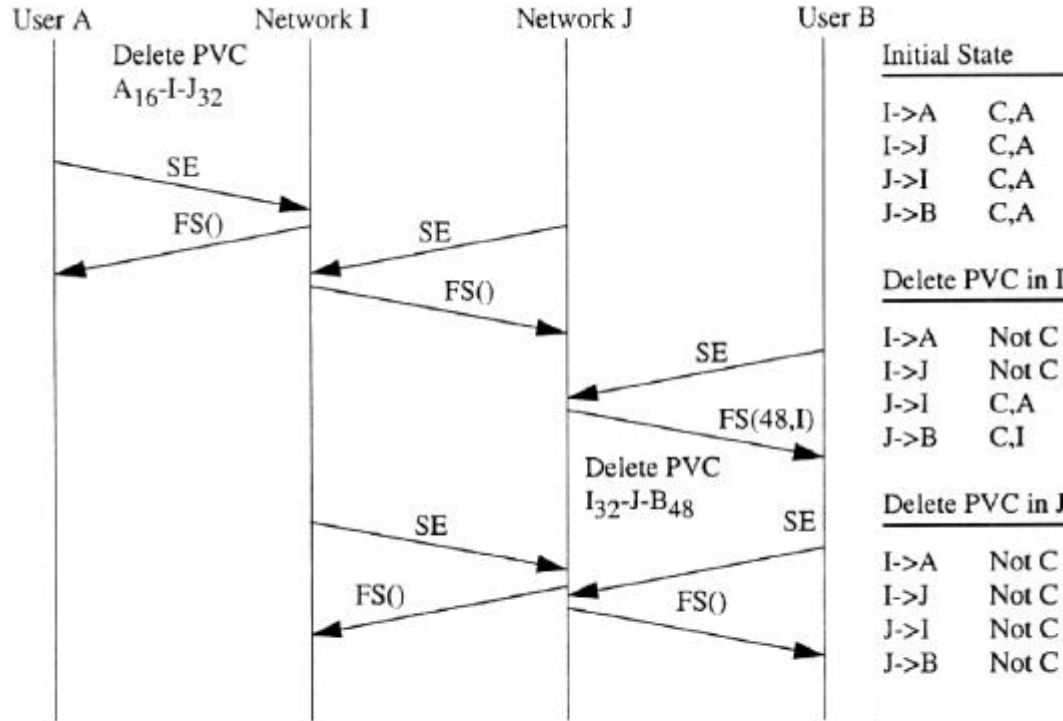

Figure 5
Deletion of a multi-network PVC

3.10.5 Example of UNI failure and restoration

Figure 6 shows the detection of an inactive channel (UNI channel) between User A and Network I (N393 valid polling cycles have not occurred). Network I notifies Network J that DLCI 32 is inactive. The inactive indication is forwarded to the PVC endpoint (User B) on Network J. The active/inactive indication from Network I to Network J is independent of the active/inactive indication from Network J to Network I. If the active bit is still set to 1 in the PVC Status Information Element for DLCI 32 in the full status reports sent from Network J to Network I.

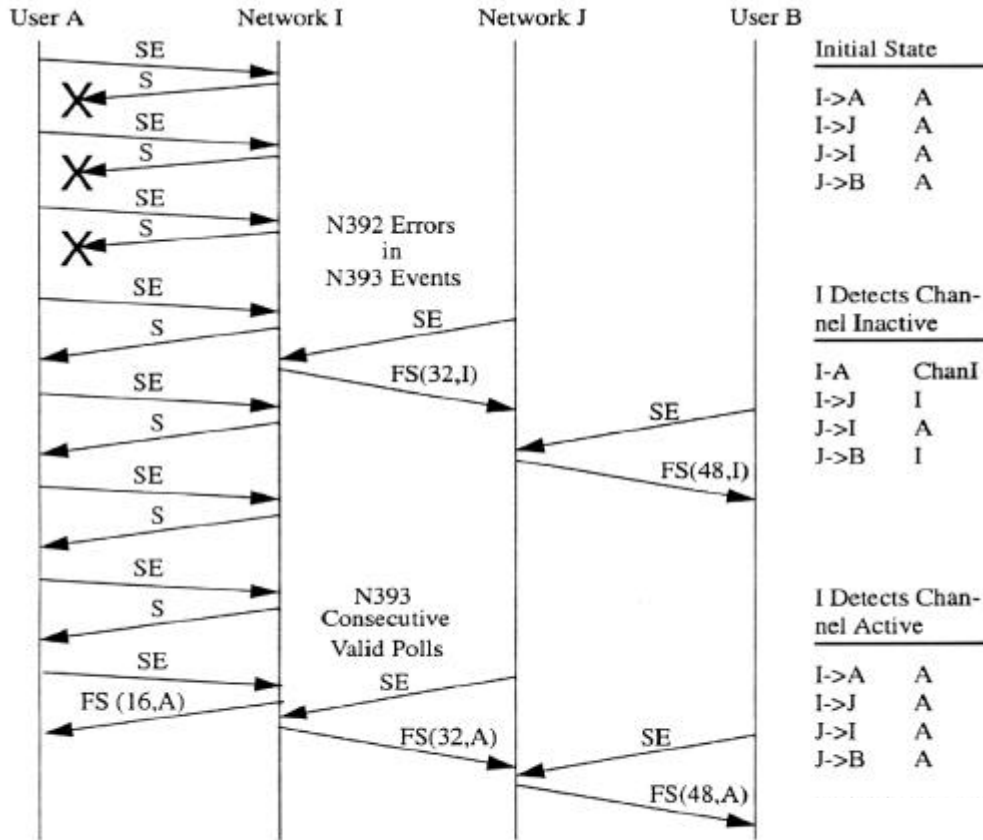

Figure 6
UNI failure and restoration

Figure 6 also shows the detection of an active channel (UNI restoration) between User A and Network I. Network I notifies Network J that DLCI 32 is active. The active indication is forwarded to the PVC endpoint (User B) on Network J. The active/inactive indication from Network I to Network J is independent of the active/inactive indication from Network J to Network I.

3.10.6 Example of PVC segment failure and restoration

Figure 7 shows the failure of a PVC segment in Network I. Network I notifies Network J that DLCI 32 is inactive. The inactive indication is forwarded to the PVC endpoint (User B) on Network J. The active/inactive indication from Network I to Network J is independent of the active/inactive indication from Network J to Network I. In Figure 7 the active bit is still set to 1 in the PVC status information element for DLCI 32 in the full status reports sent from Network J to Network I.

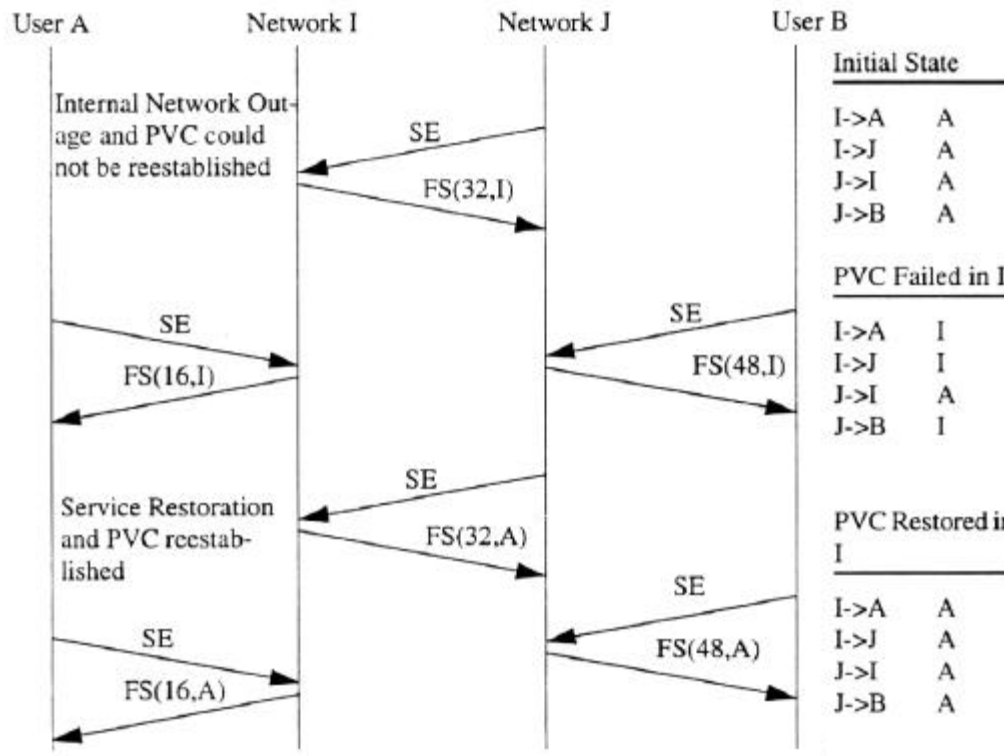

Figure 7
PVC segment failure and restoration

Figure 7 also shows the notification of a PVC segment becoming operational in Network I. Network I notifies Network J that DLCI 32 is active. The active indication is forwarded to the PVC endpoint (User B) on Network J. The active/inactive indication from Network I to Network J is independent of the active/inactive indication from Network J to Network I.

3.10.7 Example of NNI failure and restoration

Figure 8 shows the detection of an inactive channel (NNI failure) between Network I and Network J. Network I notifies the User A that DLCI 16 is inactive. Network J notifies the User B that DLCI 48 is inactive.

Figure 8 also shows the detection of an active channel (after N393 valid polling cycles) between Network I and Network J. Network I notifies the User A that DLCI 16 is active. Network J notifies the User B that DLCI 48 is active.

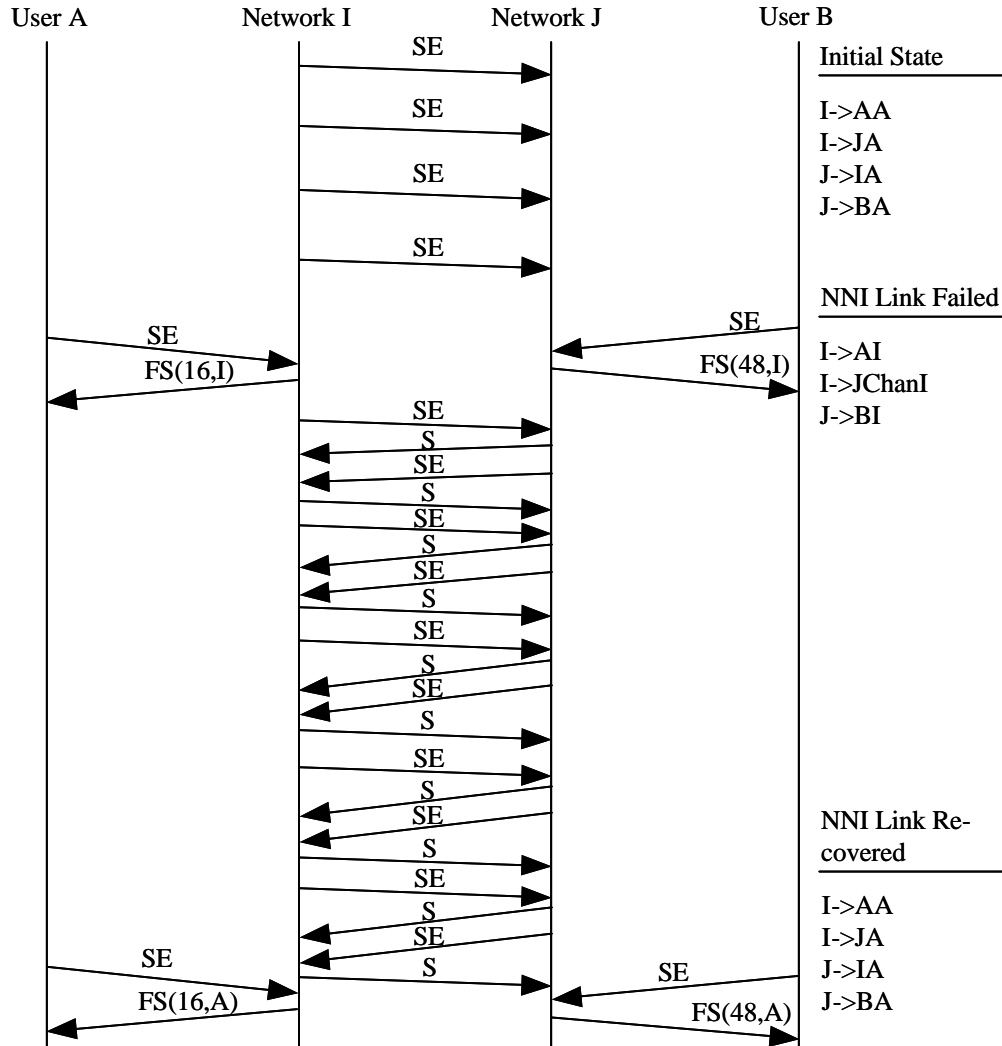

Figure 8
NNI failure and restoration

Appendix 1: Handling of physical layer loopback conditions when using frame relay PVC bi-directional procedures

(informative)

A. Recommended procedures for equipment that can detect loopback at the physical layer:

Frame relay equipment that can detect physical layer loopback conditions should internally remove the interface from service during a physical layer loopback condition. It is strongly recommended that the equipment declare a service affecting condition at the frame relay interface for the duration of the loopback condition.

B. Recommended procedures for equipment that cannot detect loopback at the physical layer:

Frame relay equipment that cannot detect loopback at the physical layer may do the following sequence number processing at the frame relay layer to handle a loopback condition.

One property of the Q.933 Annex A bidirectional procedures is its capability to operate on a transaction basis. The send sequence number has an initial value of zero but it can be incremented by any value from 1 to 255 inclusive. This property can be exploited advantageously to detect accidental loopback.

Note: The frame relay procedures cannot detect that the loopback is occurring at the physical layer. They only detect that there is a loopback condition somewhere on the interface.

The equipment suspects a loopback condition exists if the send sequence number on a message received by a procedure is equal to the send sequence count of the opposite procedure, (i.e. if the send sequence number of a received STATUS is equal to the send sequence count of the equipment's network procedures, or if the send sequence number of a received STATUS ENQUIRY is equal to the send sequence count of the equipment's user procedures). A message meeting this condition is discarded. The equipment then attempts to confirm the loopback condition.

Note: Both devices on an interface starting with the same send sequence number produces an initial false loopback condition. It is strongly recommended that the send sequence counts for the user and network procedures of both devices be initialized to unique values. This significantly reduces the probability of an initial false loopback condition.

The procedure that suspects a loopback condition confirms it by incrementing its send sequence count by a value that may be fixed or randomly generated (as opposed to incrementing by one) before it sends the next message, (i.e. If the user procedures suspect loopback, the send sequence number of the next STATUS ENQUIRY is incremented by this value. If the network procedures suspect loopback, the send sequence number of the STATUS response is incremented by this value.) A bilateral agreement should be reached to ensure that both devices on the interface do not use the same fixed value or same random number. If the next message received by the procedure opposite the one suspecting the loopback condition contains a send sequence number that matches the incremented send sequence count, the loopback condition is confirmed. The message with the matching send sequence number is discarded.

Once the loopback condition is confirmed, each message received that meets the loopback condition is discarded. This results in a service affecting condition until the loopback condition is cleared.

The equipment detects that the loopback has been cleared when it receives N392 consecutive messages where the send sequence number of the received message does not match the send sequence count of the opposite procedures. At this point it goes back to incrementing by one.