

Frame Relay/ATM PVC Network Interworking Implementation Agreement

December 20, 1994

Editor: Doug O'Leary, Bell Atlantic
Tel: 215.466.2386
Fax: 215.564.2540
Internet: douglas.g.oleary@bell-atl.com

Secretariat

Frame Relay Forum

**The Frame Relay Forum
Document Number FRF.5**

Abstract

This Implementation Agreement provides the functional requirements configurations across interfaces for network interworking between the Frame Relaying Bearer Service and B-ISDN Permanent Virtual Connection Services.

**Frame Relay / ATM Network Interworking
Implementation Agreement**

1.0 Introduction

1.1 Purpose

This document is an implementation agreement on Permanent Virtual Connection (PVC) network interworking between Frame Relay and Asynchronous Transfer Mode (ATM) technologies. The agreements herein were reached jointly by the Frame Relay and the ATM Forums and are based on the relevant standards referenced in section 2.0. These agreements address the optional parts of these standards, and document agreements reached among vendors and suppliers of frame relay and ATM products and services.

Except as noted, these agreements will form the basis of conformance test suites produced by the Frame Relay Forum and the ATM Forum.

This document may be submitted to other bodies involved in ratification of implementation agreements and conformance testing to facilitate multi-vendor interoperability.

This document does not cover Q.933/Q.2931 protocol mapping.

1.2 Overview

Section 3 provides a description of the various interworking scenarios. Section 4 provides implementation agreements with respect to the protocol interworking functions needed to support ITU-T I.555 Interworking Scenarios 1 and 2. The material in sections 3, 4, and 5 was jointly developed by the ATM Forum and the Frame Relay Forum. This document does not cover service interworking.

1.3 Definitions

The first two definitions are according to ITU-T I.555:

Protocol encapsulation occurs when the conversions in the network or in the terminals are such that the protocols used to provide one service make use of the layer service provided by another protocol. This means that at the interworking point, the two protocols are stacked. When encapsulation is performed by the terminal, this scenario is also called interworking by port access.

Protocol mapping occurs when the network performs conversions in such a way that within a common layer service, the protocol information of one protocol is extracted and mapped on protocol information of another protocol. This means that each communication terminal supports different protocols. The common layer service provided in this interworking scenario is defined by the functions which are common to the two protocols.

Must, Shall or Mandatory - the item is an absolute requirement of this implementation agreement.

Should - the item is highly desirable.

May or Optional - the item is not compulsory, and may be followed or ignored according to the needs of the implementor.

Not Applicable - the item is outside the scope of this implementation agreement.

1.4 Acronyms

AAL	ATM Adaptation Layer
ATM	Asynchronous Transfer Mode
Bc	Committed Burst
Be	Excess Burst
BECN	Backward Explicit Congestion Notification
B-ICI	Broadband Inter Carrier Interface
B-ISDN	Broadband Integrated Services Digital Network
B-TE	T-ISDN Terminal Equipment
CDV	Cell Delay Variance
CI	Congestion Indication
CIR	Committed Information Rate
CLP	Cell Loss Priority
CPE	Customer Premises Equipment
CPCS	Common Part Convergence Sub-layer
CRC	Cyclic Redundancy Check
C/R	Command/Response bit
CSU	Channel Service Unit
DE	Discard Eligibility
DLCI	Data Link Connection Identifier
DSAP	Destination Service Access Point
DSU	Data Service Unit
DTE	Data Terminal Equipment
DTP	Data Transfer Protocol
DXI	Data Exchange Interface
EA	Address Extension bit
EFCI	Explicit Forward Congestion Indicator
FECN	Forward Explicit Congestion Notification
FFS	For Further Study
FMBS	Frame Mode Bearer Service
FR	Frame Relaying
FRBS	Frame Relaying Bearer Service
FR-SSCS	Frame Relaying - Service Specific Convergence Sub-layer
FRS	Frame Relaying Service
FSBS	Frame Switching Bearer Service
GCRA	Generic Cell Rate Algorithm
IE	Information Element
IETF	Internet Engineering Task Force
ILMI	Interim Local Management Interface
ITU	International Telecommunication Union
ITU-T	ITU Telecommunications Sector
IWF	InterWorking Function
LAN	Local Area Network
LAPB	Link Access Procedure Balanced
LLC case of LAN)	Lower Layer Compatibility (in the case of ISDN) or Logical Link Control (in the
LP	Loss Priority
MAC	Media Access Control
MBS	Maximum Burst Size

MIB	Management Information Base
NLPID	Network Layer Protocol Identifier
NNI	Network to Network Interface
NPC	Network Parameter Control
OAM	Operation, Administration and Maintenance
PDU	Protocol Data Unit
PCI	Protocol Control Information
PCR	Peak Cell Rate
PLP	Packet Level Procedures
PSPDN	Packet Switched Public Data Network
PVC	Permanent Virtual Connection
QoS	Quality of Service
RFC	Request for Comments
SAP	Service Access Point
SAPI	Service Access Point Identifier
SAR	Segmentation and Reassembly
SCR	Sustainable Cell Rate
SNMP	Simple Network Management Protocol
SDU	Service Data Unit
SSAP	Source Service Access Point
SSCS	Service Specific Convergence Sub-layer
SVC	Switched Virtual Connection
TA	Terminal Adapter
TE	Terminal Equipment
U-Plane	User Plane
UNI	User to Network Interface
UPC	Usage Parameter Control
VC	Virtual Connection
VCC	Virtual Channel Connection
VCI	Virtual Channel Identifier
VPC	Virtual Path Connection
VPI	Virtual Path Identifier
WAN	Wide Area Network

2.0 Relevant Standards

The following is a list of standards and recommendations upon which this Frame Relay/ATM Interworking Agreement is based:

- ANSI T1.606 - Frame Relay Bearer Service - Architectural Framework and Service Description, American National Standards Institute, Inc., 1990.
- ANSI T1.606a - "Congestion Management" - Frame Relaying Bearer Service - Architectural Framework and Service Description, American National Standards Institute, Inc., 1991.
- ANSI T1.606b - "Network to Network Interface Requirements" - Frame Relaying Bearer Service - Architectural Framework and Service Description, August 1992.
- ANSI T1.617 - DSS1 - Signalling Specification for Frame Relay Bearer Service, American National Standards Institute, Inc., 1991.
- ANSI T1.617a - Frame Relay Bearer Service for DSS1 (protocol encapsulation and PICS).
- ANSI T1.618 - DSS1 - Core Aspects of Frame Protocol for Use with Frame Relay Bearer Service, American National Standards Institute, Inc., 1991.
- ANSI T1.633 - Frame relaying Bearer Service Interworking.
- ATM Forum - B-ICI Specification Document (Version 1.0), August 1993.

ATM Forum - UNI Specification Document (Version 3.0), August 1993.
 FRF.1 - Frame Relay User-to-Network Implementation Agreement, January 1992.
 FRF.2 - Frame Relay Network-to-Network Interface Phase 1 Implementation Agreement, August 1992.
 FRF.3 - Multiprotocol Encapsulation Over Frame Relaying Networks Implementation Agreement, July 1993.
 IETF RFC 1483 - Multiprotocol Encapsulation over ATM Adaptation Layer 5, July 1993.
 IETF RFC 1490 - Multiprotocol Interconnect over Frame Relay, July 1993.
 ISO/IEC TR 9577 - Protocol Identification in the Network Layer, October 1990.
 ITU-T AAL Type 5, Recommendation Text for Section 6 of I.363, TD-10, SG13 January 1993, Geneva.
 ITU-T I.122 - Framework for Providing Additional Packet Mode Bearer Service, ITU, Geneva, 1988.
 ITU-T I.233.1 - Frame Relaying Bearer Services, 1991.
 ITU-T I.365.1 - Frame Relaying Service Specific Convergence Sublayer (FR-SSCS), 1993.
 ITU-T I.370 - Congestion Management in Frame Relaying Networks, 1991.
 ITU-T I.372 - Frame Mode Bearer Service, Network to Network Interface Requirements, 1992.
 ITU-T I.555 - Frame Relaying Bearer Service Interworking, Com 13 R2-E, July 1994.
 ITU-T I.610 - B-ISDN Operations and Maintenance Principles and Maintenance - Proposed Text on the Loopback Capability, 1993.
 ITU-T Q.922 - ISDN Data Link Layer Specifications for Frame Mode Bearer Services, 1992.
 ITU-T Q.933 - DSS1 Signalling Specifications for Frame Mode Basic Call Control, ITU, Geneva, 1992.

3.0 Frame Relay/ATM Interworking Scenarios

This section describes Frame Relay Service (FRS) specific functions including the FR/B-ISDN Interworking Function (IWF) which is required to support carriage of the permanent virtual connection (PVC) frame relay service across a B-ISDN. This IWF conforms to ITU-T Recommendations I.555 (Frame Relaying Bearer Service Interworking) and I.365.1 (Frame Relay Service Specific Convergence Sublayer, FR-SSCS).

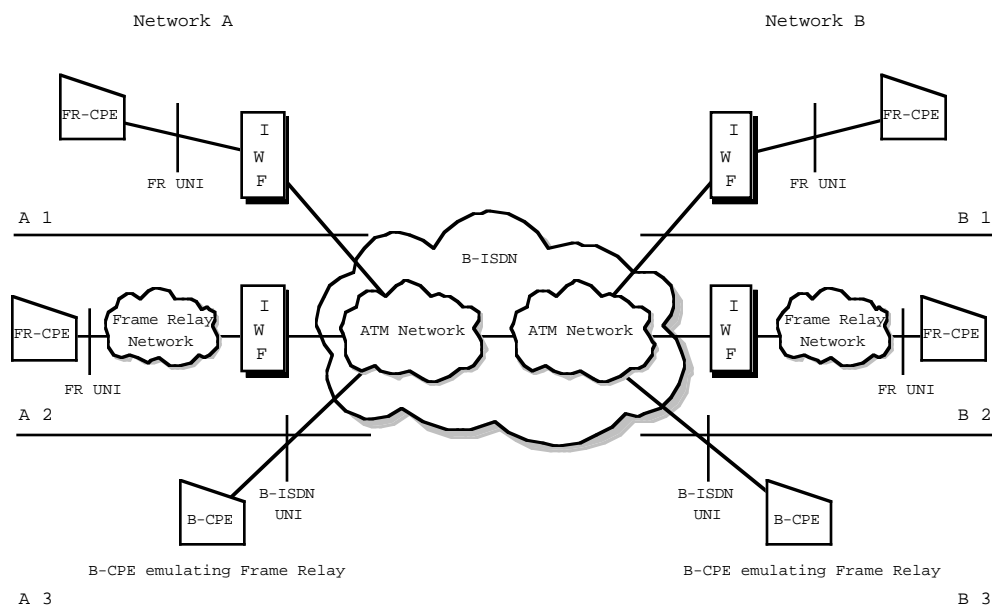

Figure 1: FRS Support on an ATM-based Multi-Service Interface

Figure 1 illustrates three FRS access configurations labeled A1 through A3 (or B1 through B3). Interconnection between any of the access configurations shall be supported. These interconnections lead to six possible reference configurations. A complete list of reference configurations is:

- | | |
|--------------|--------------|
| 1 - A1 to B1 | 4 - A2 to B2 |
| 2 - A1 to B2 | 5 - A2 to B3 |
| 3 - A1 to B3 | 6 - A3 to B3 |

Figure 1 does not imply any particular physical location for an IWF. Three examples of where the IWF may be implemented are illustrated in Figure 2.

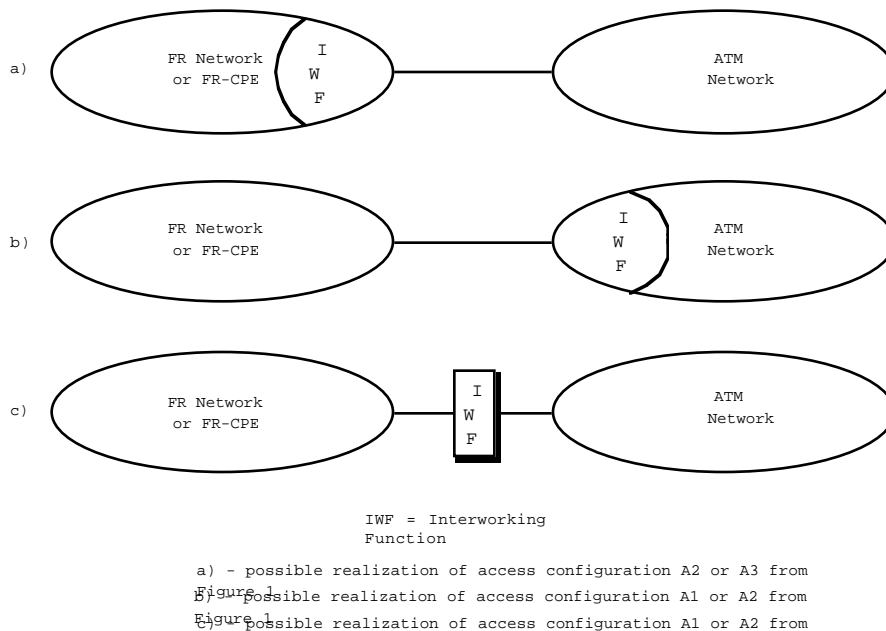

Figure 2: Example of Realizations of IWF which are Equivalent

3.1 Network Interworking Scenarios 1 and 2

There are two Network Interworking Scenarios defined in ITU-T Recommendation I.555, Section 7. Scenario 1 connects two Frame Relay Networks/CPE using B-ISDN. Scenario 2 connects a Frame Relay Network/CPE with a B-ISDN/CPE using B-ISDN. These two scenarios cover the six reference configurations described above. The two scenarios described in the following sections are based on the ATM Forum B-ICI specification.

3.1.1 Network Interworking Scenario 1

The use of the B-ISDN network by two FR Networks/CPE is not visible to the end users. The end user protocol suites remain intact. The IWF provides all mapping and encapsulation functions necessary to ensure that the service provided to the FR-TE is unchanged by the presence of an

ATM transport. See I.555 for more details. The reference configurations that are supported by Network Interworking Scenario 1 are: A1-B1, A1-B2, and A2-B2 as listed in Figure 1.

Note: Scenario 1 is also referred to as Frame Relay Transport over ATM.

The User-plane protocols associated with high speed interconnection based on ATM between two FR Network/CPE are shown in Figure 3.

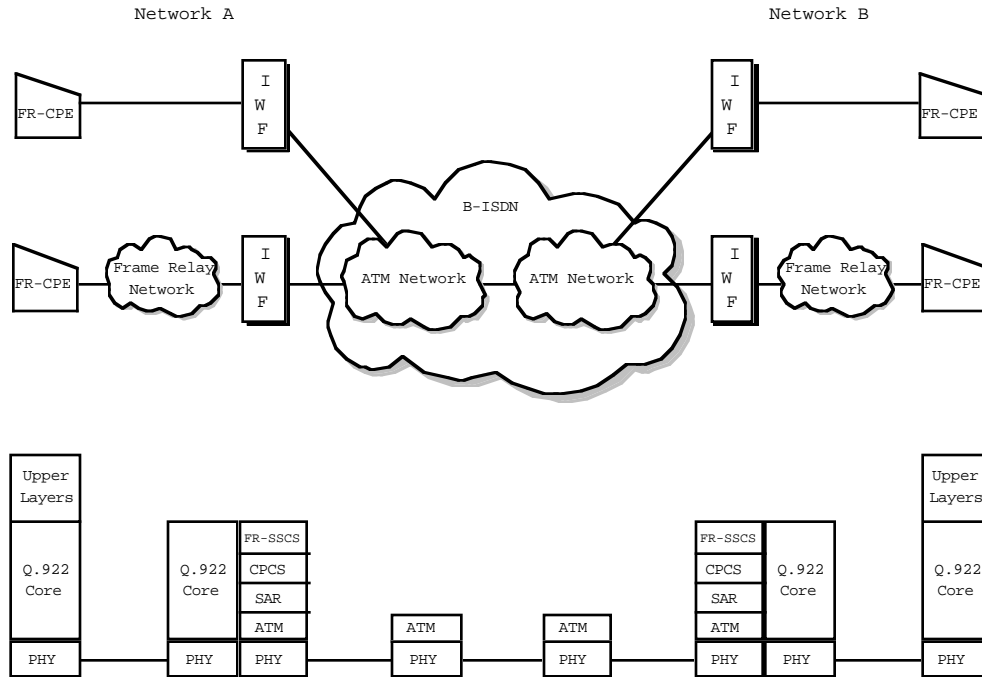

Figure 3: Network Interworking between FRBS and B-ISDN

3.1.2 Network Interworking Scenario 2

The use of the B-ISDN by a FR Network/CPE and a B-ISDN CPE is not visible to the FR end user. The B-ISDN CPE must support the FR Service Specific Convergence Sublayer (FR-SSCS) in its protocol stack. The IWF provides all functions necessary to ensure that the service provided to the FR-CPE is unchanged by the presence of an ATM transport.

The IWF is the same as that described for Network Interworking Scenario 1.

The reference configurations that are supported by Network Interworking Scenario 2 are: A1-B3 and A2-B3 as shown in Figure 1. Reference configuration (A3-B3), B-CPE to B-CPE, is not explicitly covered by I.555 Network Interworking Scenarios. No IWF exists in the network for this configuration.

The U-plane protocols associated with interconnection between FR Network/CPE and a B-ISDN CPE are shown in Figure 4.

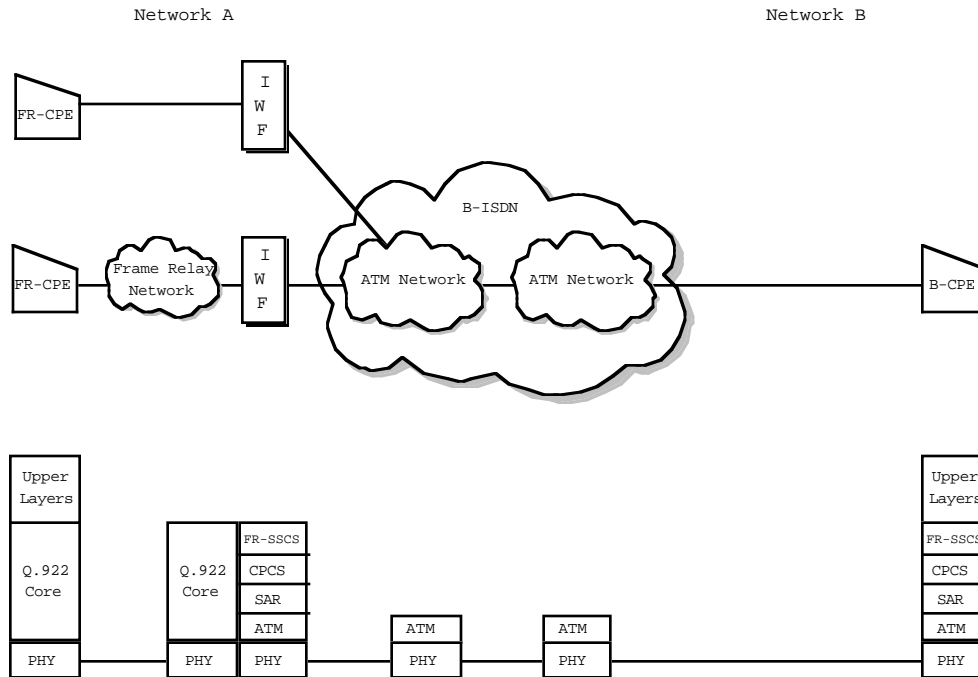

Figure 4: Network Interworking between FRBS and B-ISDN (I.555 Scenario 2)

4.0 Detailed Network Interworking Functions

The text for this section is based on the ATM Forum B-ICI specification. The IWF provides functional mapping between FRS functions and B-ISDN functions. FRS features to be supported include:

1. Variable length PDU formatting and delimiting
2. Error detection
3. Connection multiplexing
4. Loss Priority Indication
5. Congestion Indication (Forward and Backward)
6. PVC Status Management

Figure 5 illustrates the internal protocol architecture of the FR/B-ISDN IWF. The B-ISDN sublayers and the support of the above FRS features by these sublayers are described in this section.

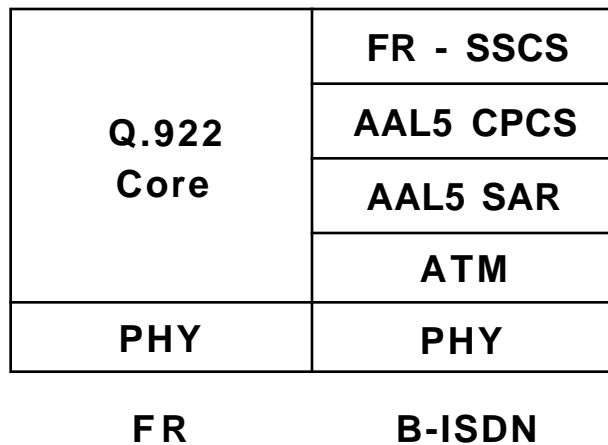

Figure 5: I.555 FR/ATM IWF Internal Architecture

4.1 Frame Formatting and Delimiting

The Frame Relay Service Specific Convergence Sublayer (FR-SSCS) uses a PDU format identical to Q.922 Core minus the CRC-16, FLAGS and zero bit insertion. The FR/ATM IWF shall use the FR-SSCS described in ITU-T I.365.1 and a PDU format structured as shown in Figure 6.

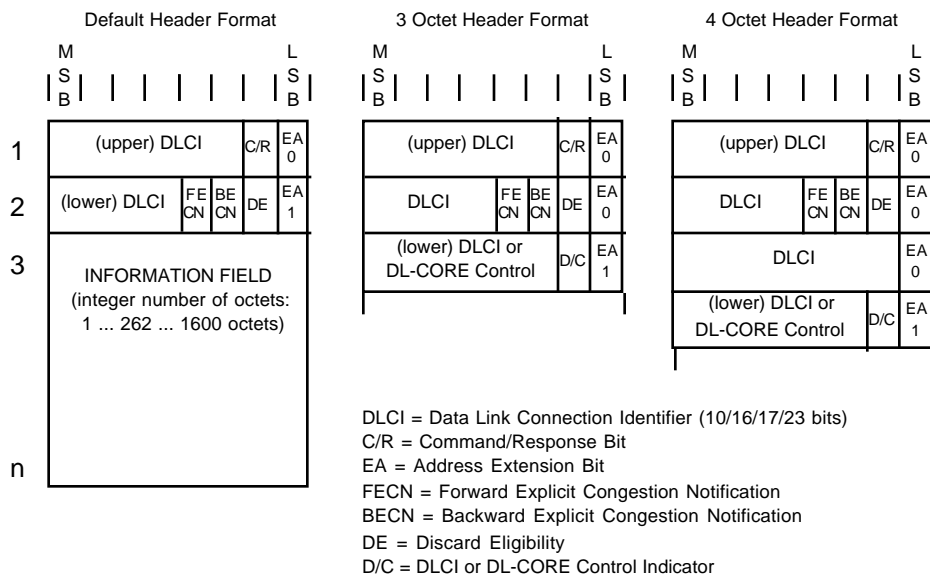

Figure 6: Structure of the FR-CS-PDU

The support of the default (2 octet) address field format is mandatory. Support of the 4 octet address field format is optional and the use of the 3 octet address field format is for further study.

The Segmentation and Reassembly (SAR) and Common Part Convergence Sublayer (CPCS) of ATM Adaptation Layer 5 in conjunction with the ATM-layer ATM_user_to_user Indication (end of PDU) provides segmentation and reassembly (frame delimiting) for FR-SSCS PDUs. The Common Part AAL-5 PDU Formats are shown in Figure 7.

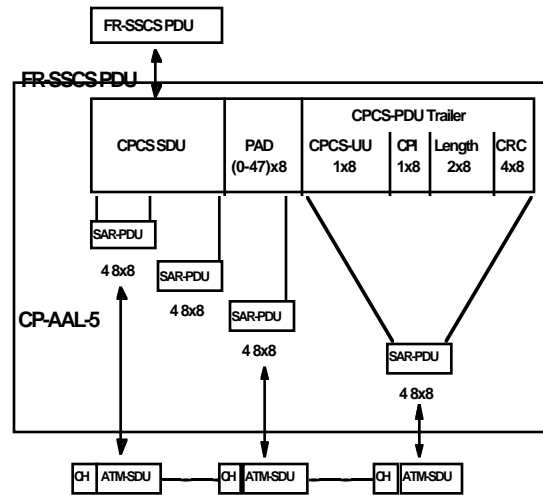

Figure 7: Common Part AAL-5 PDU Formats

The FR/ATM IWF shall utilize the AAL-5 CPCS and SAR as specified in ITU-T Recommendation I.363.

4.2 Error Detection

The AAL-5 CPCS CRC-32 provides error detection over the FR-SSCS PDU.

4.3 Connection Multiplexing

The FR-SSCS can support connection multiplexing using the Data Link Connection Identifier (DLCI) field. In addition, the ATM layer supports connection multiplexing using its VPI/VCI. ITU-T Recommendation I.555 identifies two methods of multiplexing FR connections over B-ISDN.

1. One-to-One: Each FR logical connection is mapped to a single ATM VCC. Multiplexing is performed at the ATM-layer using VPI/VCI. The IWF shall support One-to-One multiplexing. The FR-SSCS DLCI value (in the range of 16-991) used for user plane traffic should be agreed upon between the two ATM end systems (e.g., ATM end users or IWFs) or a default value of 1022 must be used. When an optional three or four octet address format is used, the address shall be formatted according to ITU-T Q.922, and the FR-SSCS DLCI value used for user plane traffic must be agreed upon between the two ATM end systems; there is no default value.

2. Many-to-One: Multiple FR logical connections are multiplexed into a single ATM Virtual Channel Connection (VCC). Multiplexing is accomplished at the FR-SSCS

sublayer using DLCIs. The Many-to-One method may be used only for FR PVCs that terminate on the same ATM-based end systems (e.g., ATM end users of IWFs). The IWF should support Many-to-One multiplexing. The FR-SSCS DLCI value(s) used shall be agreed upon between the two ATM end systems (e.g., ATM end users or IWFs).

An objective is that many-to-one and one-to-one multiplexing schemes should interoperate.

4.4 Discard Eligibility and Cell Loss Priority Mapping

4.4.1 Frame Relay to B-ISDN Direction

The network provider can select between two modes of operation for loss priority mapping in the FR to B-ISDN direction. IWF equipment shall support both of the following two modes, selectable for each ATM connection. See Figure 8 for the exact DE/CLP mapping.

Mode 1: The Discard Eligibility (DE) field in the Q.922 core frame shall be copied unchanged into the DE field in the FR-SSCS PDU header and mapped to the ATM Cell Loss Priority (CLP) of every ATM cell generated by the segmentation process of that frame.

Mode 2: The DE field in the Q.922 core frame shall be copied unchanged into the DE field in the FR-SSCS PDU header and the ATM Cell Loss Priority of every ATM cell generated by the segmentation process of that frame shall be set to a constant value (either 0 or 1). The value is decided when the connection is set up, and is used for all cells generated from the segmentation process of every frame, until the ATM connection characteristics are changed. This is not intended to restrict any actions that UPC/NPC might take resulting in changing the CLP.

4.4.2 B-ISDN to Frame Relay Direction

The network provider can select between two modes of operation for loss priority mapping in the B-ISDN to FR direction. IWF equipment shall support both of the following two modes, selectable for each ATM connection. See Figure 8 for the the exact DE/CLP mapping.

Mode 1: If one or more ATM cells belonging to a frame has its CLP field set to one or if the DE field of the FR-SSCS PDU is set to one, the IWF shall set the DE field of the Q.922 core frame.

Mode 2: No mapping is performed from the ATM layer to Q.922 core layer. The FR-SSCS PDU DE field is copied unchanged to the Q.922 core frame DE field, independent of CLP indications(s) received at the ATM layer.

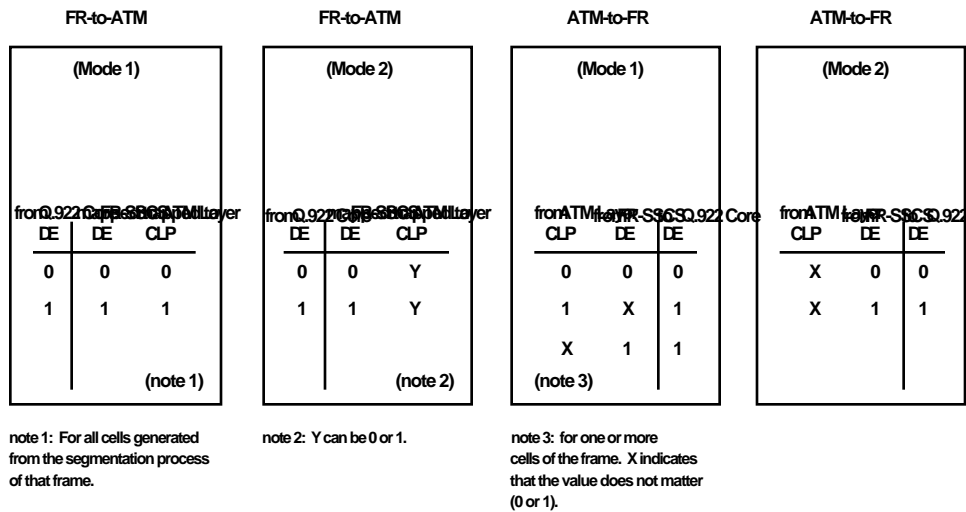

Figure 8: DE/CLP Mapping

4.5 Congestion Indication

4.5.1 Congestion Indication (Forward)

Forward congestion indication is supported at the frame level with Forward Explicit Congestion Notification (FECN) and at the cell level with Explicit Forward Congestion Indication (EFCI).

4.5.1.1 Frame Relay to B-ISDN Direction

Frame level FECN is not mapped to cell level EFCI (see Figure 9).

The FECN Field of the Q.922 core Frame shall be copied unchanged into the FECN field in the FR-SSCS PDU. The EFCI field of all ATM cells shall always be set to congestion not experienced.

4.5.1.2 B-ISDN to Frame Relay Direction

Cell level EFCI is mapped to frame level FECN (see Figure 9).

If the EFCI field in the last ATM cell of a segmented frame received is set to 'congestion experienced', or if the FECN field of the received FR-SSCS PDU is set to 'congestion experienced', then the IWF shall set the FECN of the Q.922 core frame.

FR-to-ATM			ATM-to-FR		
Q.922 FECN	SSCS FECN	ATM EFCI	ATM EFCI	SSCS FECN	Q.922 FECN
0	0	0	0	0	0
1	1	0	X	1	1
			1	X	1

NOTE: 0 indicates congestion not experienced
 1 indicates congestion experienced
 x indicates that the value does not matter (0 or 1)

Figure 9: FECN/EFCI Mapping

4.5.2 Congestion Indication (Backward)

Backward congestion indication is supported only at the frame level by the Backward Explicit Congestion Notification (BECN) field.

4.5.2.1 B-ISDN to Frame Relay Direction

The BECN field in the FR-SSCS PDU shall be copied unchanged into the BECN field of the Q.922 core frame.

4.5.2.2 Frame Relay to B-ISDN Direction

The BECN field in the FR-SSCS PDU shall be set to 'congestion experienced' by the IWF if either of the following two conditions is met:

1. BECN is set in the Q.922 core frame relayed in the FR to B-ISDN direction, or
2. EFCI was set to 'congestion experienced' in the last ATM cell of the last segmented frame received in the B-ISDN to FR direction for this bi-directional connection (i.e., EFCI set to 'congestion experienced' due to FECN mapping was performed by the IWF in the B-ISDN to FR direction).

A mechanism may be needed to exit the congestion state depending on the traffic activity of the ATM virtual channel. For example, as shown in the congestion state diagram in Figure 10, a timer can be used to reset the congestion state (condition 2 described above) after a time period T if no new congestion information is received in the B-ISDN to Frame Relay direction. If the EFCI of the last cell of the next frame received is not set, the congestion state is cleared. Otherwise, the timer is restarted. The value of the FECN received in the FR-SSCS PDU is not mapped to the BECN of the FR-SSCS PDU in the opposite direction.

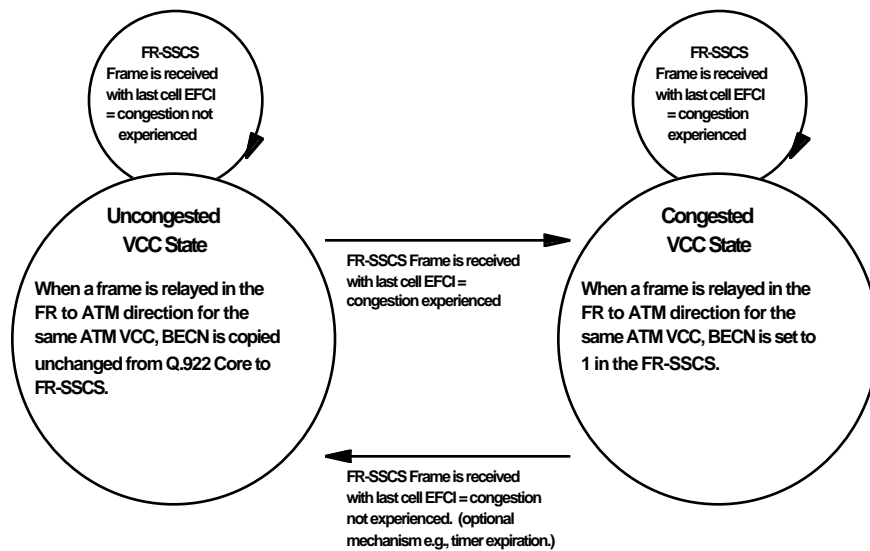

Figure 10: Congestion State Diagram for VCC

5.0 Additional FR-ATM Interworking Aspects

5.1 Traffic Management

The ATM Forum FR-ATM traffic management work, in Appendix A of the ATM Forum B-ICI Specification, provides guidelines for conversion of Frame Relay traffic conformance parameters (Throughput, Committed Burst Size, Excess Burst Size, Access Rate) to ATM traffic conformance parameters (PCR, CDV, SCR, MBS) using the GCRA (Generic Cell Rate Algorithm) configurations for Frame Relay interworking described in Examples 2a and 2b of section 3.6 of the ATM UNI Specification version (3.0).

The ATM traffic conformance parameter determination guidelines from Frame Relay traffic conformance parameters for one-to-one mapping, as described in Appendix A of the ATM Forum B-ICI Specification shall be used by network providers for FR-ATM Interworking traffic management. Two methods are provided in the appendix for determination of ATM traffic conformance parameters from Frame Relay traffic conformance parameters. The first method provides accurate representation of FR traffic parameters in an ATM network. The selection of one of the two methods shall be decided by bilateral agreement between networks.

5.2 PVC Management

The text for this section is based on the ATM Forum B-ICI specification. The management of the ATM layer and the FR PVC Status Management of the FR-SSCS layer can operate independently. Each layer has its own responsibility for the layer management (e.g., some functions of the management in the ATM layer will be performed by usage of the OAM cell flows). The PVC status from the ATM Layer shall be used by the FR-SSCS layer when determining the status of the FR PVCs.

The management of FR PVCs for FR UNI and FR NNI will remain unchanged. The PVC management procedures described here only covers the management of the FR PVCs carried by the ATM network (i.e., FR-SSCS management). The protocol stacks of the IWF and the FRS supporting B-CPE with status management are shown in Figure 11.

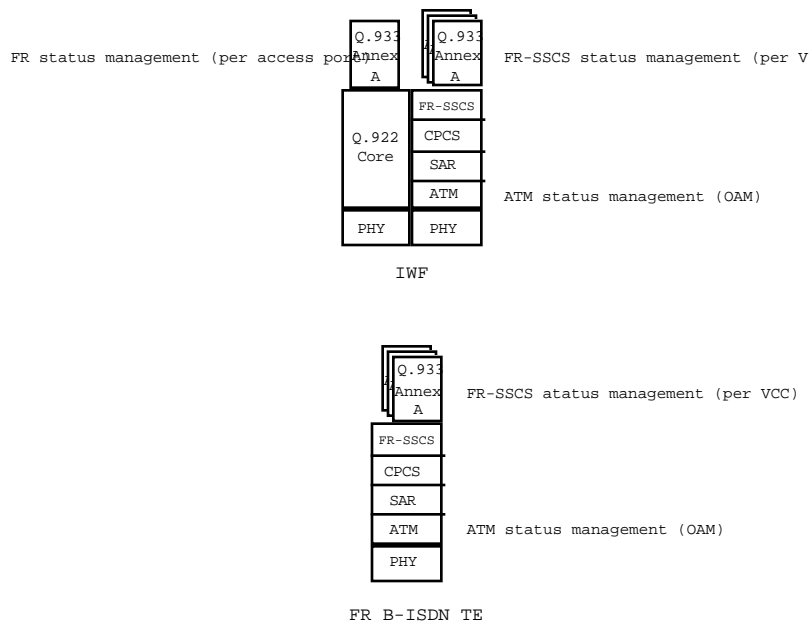

Figure 11: PVC Status Management Interworking Protocol Stack

The management of the FR-SSCS layer shall be performed by bi-directional (symmetric) PVC management procedures adopted from the ITU-T Recommendation Q.933 Annex A. Selection of specific options within the Q.933 Annex A shall be aligned with FRF.2 - Frame Relay Network-to-Network Interface Implementation Agreement.

Note: This applies for the B-CPE emulating FR (Figure 1). This allows all six connection possibilities of Figure 1 including the A3 to B3 case.

For FR PVC Status Management of FR connection(s) carried by an ATM VCC, DLCI = 0 is used

to exchange PVC status management between IWF(s) and/or B-CPE emulating FR.

In the case of one-to-one multiplexing, the procedures described in ITU-T Q.933 Recommendation Annex A apply with the following changes:

1. The N391 Full Status Polling counter default is set to 1.
2. The T391 Link Integrity Verification Polling timer and the T392 Polling Verification timer default values are set to 180 and 200 seconds respectively.
3. The use of the Frame Relay asynchronous message as specified in Q.933 Annex A is recommended.

Link Integrity Verification of ATM VCCs is provided by ATM OAM F5 flows. The ATM VCC status obtained by the OAM F5 flow is conveyed to the Q.933 Annex A entity.

5.3 Description of Upper Layer User Protocol Encapsulation Methods

Higher-layer protocols may be conveyed between TEs using the Frame Relay Forum Multiprotocol Encapsulation Implementation Agreement (FRF.3). Multiprotocol encapsulation procedures shall be used only when explicitly configured or agreed during connection establishment.

The Frame Relay Forum Multiprotocol Encapsulation Implementation Agreement is based on IETF RFC 1490 and ANSI T1.617a Annex F. The key element of this method is the identification of the encapsulated higher-layer protocol using NLPID (Network Layer Protocol ID, as defined in ISO/IEC TR 9577). This method has been adopted for encapsulation over Frame Relay.

The B-TE has to implement NLPID encapsulation when using ATM-FR network interworking. The Frame Relay TE implements NLPID encapsulation.

5.4 Operations and Maintenance

The text for this section is based on the ATM Forum B-ICI specification. This Section provides the AAL Type 5 operations above the ATM layer. Operations for layers above the AAL are not discussed in this Version. Section 5.4.1 discusses operations for the common part of the AAL Type 5.

5.4.1 Operations for the Common Part of the AAL Type 5

This Section specifies performance measurements needed to monitor errors for the common part of the AAL Type 5. Figure 12 shows the format of the common part of the AAL Type 5 PDU (I.363). In this Figure, the CPCS-UU is the Common Part Convergence Sublayer - User-to-User indication field. It is used to transfer user-to-user information, and so is not monitored by the network.

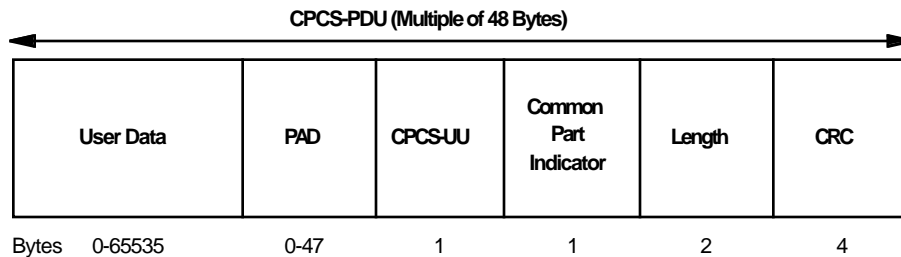

Figure 12: Format of the Common Part of the AAL Type 5 PDU (I.363)

The following error conditions may occur at the receiving point:

- Invalid format of Common Part Indicator (CPI) field. The only valid value currently defined for the CPI field is all zeros.
- Length violation. An error occurs when the Length, which is measured in bytes, is not consistent with the length of the CPCS-PDU. If the length of the CPCS-PDU in bytes minus the value of the Length field is not in the range 8-55 (PAD plus the remaining eight octets), the two are not consistent. One exception is when the Length field has a value of zero, which is an indication of a forward abort. This case shall not be counted as a length violation.
- Oversized Received Service Data Unit (SDU): This error condition occurs if a partial or whole CPCS-PDU is received in which the SDU (i.e., User Data) exceeds the maximum allowed length.
- CRC violation.
- If the receiving entity implements a reassembly timer (which is optional, as specified in I.363), then the number of timer expirations shall be counted.

Network equipment at a B-ICI terminating the AAL Type 5 common part shall count the occurrences of the listed errors at the receiving point.

A typical value for a measurement interval could be fifteen minutes, and a least eight hours of history should be kept. The measurement interval and amount of history data will be established by bilateral agreements between carriers.