



**E**UROPEAN  
**T**ELECOMMUNICATION  
**S**TANDARD

**ETS 300 407**

March 1997

---

Source: ETSI TC-TM

Reference: DE/TM-04006

ICS: 33.020

**Key words:** DRRS, radio, digital, analogue, video, transmission

**Transmission and Multiplexing (TM);  
Parameters for Digital Radio Relay Systems (DRRS)  
for the transmission of digital signals and analogue  
video signals operating around 55 GHz**

**ETSI**

European Telecommunications Standards Institute

**ETSI Secretariat**

**Postal address:** F-06921 Sophia Antipolis CEDEX - FRANCE

**Office address:** 650 Route des Lucioles - Sophia Antipolis - Valbonne - FRANCE

**X.400:** c=fr, a=atlas, p=etsi, s=secretariat - **Internet:** secretariat@etsi.fr

Tel.: +33 4 92 94 42 00 - Fax: +33 4 93 65 47 16

---

**Copyright Notification:** No part may be reproduced except as authorized by written permission. The copyright and the foregoing restriction extend to reproduction in all media.

© European Telecommunications Standards Institute 1997. All rights reserved.



## Contents

Foreword .....	5
1 Scope .....	7
2 Normative references .....	7
3 Abbreviations .....	8
4 General characteristics .....	8
4.1 Frequency bands and channel arrangements .....	8
4.1.1 Frequency band .....	8
4.1.2 Co-polar channel spacing .....	9
4.1.3 Transmit/receive centre gap .....	9
4.1.4 Transmit/receive duplex frequency separation .....	9
4.2 Compatibility requirements between systems .....	9
4.3 Types of installation .....	9
4.3.1 Environmental conditions .....	9
4.3.1.1 Equipment within weather protected locations .....	9
4.3.1.2 Equipment for non-weather protected locations .....	9
4.3.2 Electromagnetic compatibility .....	10
4.4 Block diagram .....	10
4.5 General characteristics .....	10
4.6 Transmission Management Network (TMN) interface .....	10
4.7 Branching/feeder/antenna requirements .....	10
4.8 Mechanical requirements .....	12
4.9 Power supply .....	12
5 Parameters for digital systems .....	12
5.1 Transmission capacity .....	12
5.2 Applications .....	12
5.3 Baseband parameters .....	12
5.3.1 2 Mbit/s to 140 Mbit/s baseband interfaces .....	12
5.3.2 Synchronous Digital Hierarchy (SDH) baseband interface .....	13
5.4 Transmitter characteristics .....	13
5.4.1 Transmitter power range .....	13
5.4.2 Transmitter output power tolerance .....	13
5.4.3 RF spectrum mask .....	13
5.4.3.1 SRL formula .....	13
5.4.3.2 Residual carrier test .....	13
5.4.4 Spurious emissions .....	14
5.4.5 RF frequency tolerance .....	14
5.5 Receiver characteristics .....	14
5.5.1 Input level range .....	14
5.5.2 Spurious emissions .....	14
5.6 System performance .....	14
5.6.1 BER performance .....	14
5.6.2 Equipment background BER .....	15
5.6.3 Interference sensitivity .....	15
5.6.4 Distortion sensitivity .....	15
6 Parameters for wideband analogue systems .....	16
6.1 Transmit/receive capacity .....	16
6.2 Applications .....	16
6.3 Baseband parameters .....	16
6.3.1 Video interfaces .....	16
6.3.2 Audio interface (if applicable) .....	16
6.3.3 Digital interface (if applicable) .....	16

6.3.4	Intermediate Frequency (IF) interface (if applicable) .....	17
6.3.5	Baseband performance .....	17
6.4	Transmitter characteristics .....	17
6.4.1	Transmitter power range .....	17
6.4.2	Transmitter output power tolerance .....	17
6.4.3	Radiated spectrum .....	17
6.4.3.1	Spectrum masks .....	17
6.4.3.2	Frequency deviation .....	18
6.4.4	Spurious emissions .....	18
6.4.5	RF frequency tolerance .....	18
6.5	Receiver characteristics .....	19
6.5.1	Input level range .....	19
6.5.2	Spurious emissions .....	19
6.5.3	Noise figure .....	19
6.6	Transmit/receive performance .....	19
6.6.1	Receiver threshold .....	19
6.6.2	Interference sensitivity .....	19
Annex A (informative):	Additional information .....	28
A.1	Performance prediction and objectives .....	28
History	.....	29

## Foreword

This European Telecommunication Standard (ETS) has been produced by the Transmission and Multiplexing (TM) Technical Committee of the European Telecommunications Standards Institute (ETSI).

This ETS specifies the minimum performance parameters for radio equipment operating at frequencies around 55 GHz, as specified in the scope. Other standards cover radiocommunications equipment not listed in clause 1.

<b>Transposition dates</b>	
Date of adoption:	21 February 1997
Date of latest announcement of this ETS (doa):	30 June 1997
Date of latest publication of new National Standard or endorsement of this ETS (dop/e):	31 December 1997
Date of withdrawal of any conflicting National Standard (dow):	31 December 1997

Blank page

## 1 Scope

This ETS covers the minimum performance requirements for terrestrial fixed services radiocommunications equipment, as given below, at frequencies around 55 GHz.

This ETS specifies the performance criteria for the different equipment groups. The equipment groups are:

- digital signals;
- analogue video signals.

## 2 Normative references

This ETS incorporates by dated and undated reference, provisions from other publications. These normative references are cited at the appropriate places in the text and the publications are listed hereafter. For dated references, subsequent amendments to or revisions of any of these publications apply to this ETS only when incorporated in it by amendment or revision. For undated references the latest edition of the publication referred to applies.

- [1] ETS 300 132-1: "Equipment Engineering (EE); Power supply interface at the input to telecommunications equipment; Part 1: Operated by alternating current (ac) derived from direct current (dc) sources".
- [2] ETS 300 132-2: "Equipment Engineering (EE); Power supply interface at the input to telecommunications equipment; Part 2: Operated by direct current (dc)".
- [3] ETS 300 019: "Equipment Engineering (EE); Environmental conditions and environmental tests for telecommunications equipment".
- [4] CCITT Recommendation G.703: "Physical/electrical characteristics of hierarchical digital interfaces".
- [5] ITU-T Recommendation G.707: "Synchronous digital hierarchy bit rates".
- [6] ITU-T Recommendation G.708: "Network node interface for the synchronous digital hierarchy".
- [7] ITU-T Recommendation G.709: "Synchronous multiplexing structure".
- [8] CCITT Recommendation G.781: "Structure of Recommendations on multiplexing equipment for the synchronous digital hierarchy (SDH)".
- [9] CCITT Recommendation G.782: "Types and general characteristics of synchronous digital hierarchy (SDH) multiplexing equipment".
- [10] CCITT Recommendation G.783: "Characteristics of synchronous digital hierarchy (SDH) multiplexing equipment functional blocks".
- [11] CCITT Recommendation G.784: "Synchronous digital hierarchy (SDH) management".
- [12] ITU-R Recommendation 403: "Intermediate-frequency characteristics for the interconnection of analogue radio-relay systems".
- [13] ETS 300 385: "Radio Equipment and Systems (RES); ElectroMagnetic Compatibility (EMC) standard for digital fixed radio links and ancillary equipment with data rates at around 2 Mbit/s and above".
- [14] ITU-T Recommendation G.773: "Protocol suites for Q-interfaces for management of transmission systems".

- [15] ITU-R Recommendation F.696-1: "Error performance and availability objectives for hypothetical reference digital sections utilizing digital radio-relay systems forming part or all of the medium-grade portion of an ISDN connection".
- [16] ITU-R Recommendation F.697-1: "Error performance and availability objectives for the local-grade portion at each end of an ISDN connection utilizing digital radio-relay systems".
- [17] CCIR Report 338: "Propagation data and prediction methods required for terrestrial line-of-sight systems".
- [18] CCIR Report 563: "Radiometeorological data".
- [19] CCIR Report 721: "Attenuation by hydrometers, in particular precipitation, and other atmospheric particles".
- [20] CCIR Report 1053: "Error performance and availability objectives for digital radio-relay systems used in the local-grade portion of an ISDN connection".

### 3 Abbreviations

For the purposes of this ETS, the following abbreviations apply:

ac	alternating current
BER	Bit Error Ratio
C/I	Carrier/Interference
dc	direct current
IF	Intermediate Frequency
FM	Frequency Modulation
ppm	parts per million
PAL	Phase Alternation Line
RF	Radio Frequency
RSL	Receiver Signal Level
SDH	Synchronous Digital Hierarchy
SRL	Spectrum Reference Level

### 4 General characteristics

#### 4.1 Frequency bands and channel arrangements

##### 4.1.1 Frequency band

The frequency band is 54,25 GHz to 57,2 GHz.

NOTE: The frequency band values considered are provisional.

The channel plan is constructed on a basic raster of 14 MHz.



#### 4.1.2 Co-polar channel spacing

Table 1: Digital systems

Minimum system rate (Mbit/s)	Maximum channel spacing (MHz)
2	14
8	28
34	56
140/155	140

Table 2: Analogue systems

Video baseband (MHz)	< 3,5	< 6	< 10	< 14
Channel spacing (MHz)	42	70	70	70

#### 4.1.3 Transmit/receive centre gap

The centre gap shall be taken as a multiple of the basic raster distance of 14 MHz, and shall not be greater than 70 MHz.

#### 4.1.4 Transmit/receive duplex frequency separation

The transmitter receiver duplex frequency separation shall not be less than 500 MHz. (Typical separations will be around 1 000 MHz.)

### 4.2 Compatibility requirements between systems

In order to provide compatibility between systems there should be no requirement to operate transmitting equipment from one manufacturer with receiving equipment from another.

### 4.3 Types of installation

The equipment may comprise both radio relay units in weather protected locations, and outdoor units with the Radio Frequency (RF) assemblies located close to the antenna in order to minimize feeder losses.

#### 4.3.1 Environmental conditions

The equipment shall be required to meet the environmental conditions set out in ETS 300 019 [3], which defines weather protected and outdoor environmental classes and test severities.

##### 4.3.1.1 Equipment within weather protected locations

Equipment intended for operation within temperature controlled locations or partially temperature controlled locations shall meet the requirements of ETS 300 019 [3] classes 3.1 and 3.2 respectively.

Optionally, the more stringent requirements of ETS 300 019 [3] classes 3.3 (non-temperature controlled locations), 3.4 (sites with heat trap) and 3.5 (sheltered locations) may be applied.

##### 4.3.1.2 Equipment for non-weather protected locations

Equipment intended for operation within non-weather protected locations shall meet the requirements of ETS 300 019 [3], class 4.1 or 4.1E

Class 4.1 applies to many European countries and class 4.1E applies to all European countries.

Weather protected equipment conforming to classes 3.3, 3.4 and 3.5, together with an enclosure or

cabinet may fulfil the requirements of operating in a non-weather protected environment, but this is outside the scope of this ETS.

#### 4.3.2 Electromagnetic compatibility

Equipment shall operate under the conditions specified in ETS 300 385 [13].

#### 4.4 Block diagram

The RF block diagram is shown in figure 1.

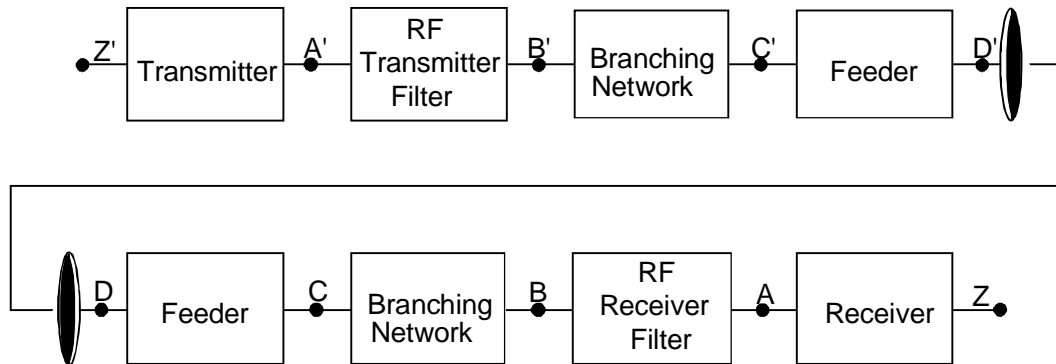

NOTE 1: For the purpose of defining the measurement points, the branching network does not include a hybrid.

NOTE 2: Points B, C, D, and B, C, D, D' may coincide.

Figure 1: RF block diagram

#### 4.5 General characteristics

The following characteristics are desirable:

- tuning facilities;
- flexibility for location of systems;
- wayside traffic facilities;
- transmitter identification;
- maintenance facilities;
- performance monitoring facilities.

#### 4.6 Transmission Management Network (TMN) interface

Any TMN interface required should follow CCITT Recommendation G.784 [11] and ITU-T Recommendation G.773 [14]. This subject is also under study in ETSI TM 2 and TM 3.

#### 4.7 Branching/feeder/antenna requirements

- a) the minimum recommended antenna radiation pattern envelope is shown in figure 2, element 2A. It may be necessary to use a higher performance antenna pattern as shown in figure 2, element 2B;
- b) antenna flange/equipment feeder flange. When flanges are required, IEC type R620 should be used.

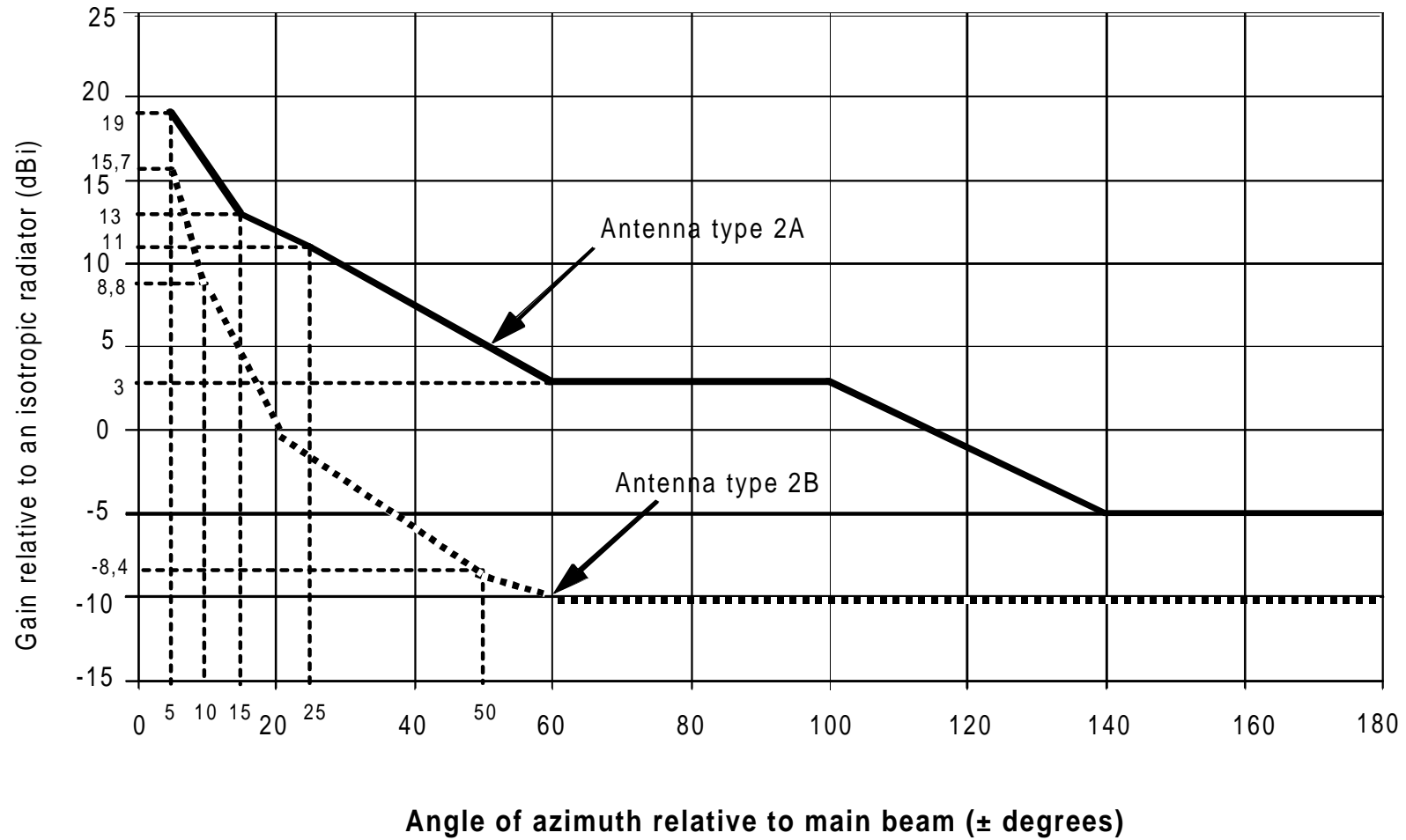

Figure 2: Limits of antenna gain for angles greater than 5° from the main beam axis

#### 4.8 Mechanical requirements

The following parameters should be taken into account in the design of equipment incorporating an external unit:

- a) maximum weight of external unit;
- b) size of external unit for wind loading considerations;
- c) maximum weight of replaceable units;
- d) ease of access to replaceable units.

#### 4.9 Power supply

The equipment shall operate from any of the primary supplies within the ranges specified in ETS 300 132-1 [1] and ETS 300 132-2 [2].

**Table 3: ETS 300 132-1 [1] and ETS 300 132-2 [2] voltage tolerances**

Nominal voltage	Tolerance
48 V dc	40,5 V to 57 V
60 V dc	50 V to 72 V
230 V ac	207 V to 253 V (50 Hz $\pm$ 2 Hz)

For dc systems, the positive pole of the battery should be earthed.

NOTE: Some countries may require the use of a primary supply of 24 V.

### 5 Parameters for digital systems

#### 5.1 Transmission capacity

Bit rates: 2 Mbit/s, 8 Mbit/s, 34 Mbit/s, 140 Mbit/s and 155 Mbit/s (STM-1).  
System rates configured as n x 2 Mbit/s are also considered.

#### 5.2 Applications

2 Mbit/s to 155 Mbit/s point-to-point local and regional networks, mobile base station connections, subscriber access links (including transportable and off-shore use).

#### 5.3 Baseband parameters

##### 5.3.1 2 Mbit/s to 140 Mbit/s baseband interfaces

**Table 4: Baseband interfaces for 2 Mbit/s to 140 Mbit/s**

Parameter	Bit rate (Mbit/s) - plesiochronous			
	2	8	34	140
Electrical interface	G.703	G.703	G.703	G.703
Service channels (optional)	64 kbit/s	64 kbit/s	64 kbit/s	64 kbit/s
Wayside traffic (optional)	-	-	704 kbit/s or 2,048 Mbit/s	704 kbit/s or 2,048 Mbit/s

NOTE: G.703 refers to CCITT Recommendation G.703 [4].

### 5.3.2 Synchronous Digital Hierarchy (SDH) baseband interface

The SDH baseband interface shall be in accordance with ITU-T Recommendations G.703 [4], G.707 [5], G.708 [6], G.709 [7], G.781 [8], G.782 [9], G.783 [10] and G.784 [11]. This subject is also under study in ETSI TM 3.

### 5.4 Transmitter characteristics

#### 5.4.1 Transmitter power range

Maximum output power up to 0 dBW referred to point D' of the RF block diagram given in figure 1.

#### 5.4.2 Transmitter output power tolerance

The output power tolerance shall be within:

±4 dB: classes 3.3 to 3.5 (defined in subclause 4.3.1.1); and  
 all classes defined in subclause 4.3.1.2;

±3 dB: classes 3.1 and 3.2 (defined in subclause 4.3.1.1).

#### 5.4.3 RF spectrum mask

The equipment shall comply with the digital RF power spectrum mask given in figures 3 to 6. The 0 dB Spectrum Reference Level (SRL) shown on the spectrum masks shall be set to the level calculated by the formula in subclause 5.4.3.1.

Due to the modulation process spectrum peaks may reach a value up to 6 dB above the SRL given in figures 3 to 6, between 0 MHz and the first break-point of the mask (shown as a dotted line). All spectrum masks include the allowance for frequency tolerance given in subclause 5.4.5.

**Table 5: Spectrum analyser settings for RF power spectrum measurements**

Bit rate	(Mbit/s)	2	8	34	140 and 155 (STM-1)
Channel spacing	(MHz)	14	28	56	140
Resolution bandwidth	(kHz)	30	100	100	300
Total sweep width	(MHz)	As appropriate			
Video bandwidth	(kHz)	0,1	0,1	1	1

##### 5.4.3.1 SRL formula

The SRL shall be calculated using the following formula:

$$0 \text{ dB SRL} = \text{carrier power} - 10 \log_{10} \left( \frac{\text{Symbol rate (Baud)}}{\text{analyser resolution bandwidth (Hz)}} \right) \text{ dBW}$$

##### 5.4.3.2 Residual carrier test

The residual carrier level shall not exceed -10 dB relative to the level of the unmodulated carrier.

#### 5.4.4 Spurious emissions

The transmitter shall be unmodulated, and the level of each spurious emission in the frequency range 1 GHz to 120 GHz, shall not exceed:

$\geq 1$  GHz and  $< 21,2$  GHz: -90 dBW;

$\geq 21,2$  GHz and  $< 80$  GHz: -60 dBW;

$\geq 80$  GHz and  $\leq 120$  GHz: -50 dBW.

NOTE 1: All levels should be measured at point D'.

NOTE 2: Spurious emissions are emissions at frequencies which are outside the necessary bandwidth and the level of which may be reduced without affecting the corresponding transmission of information. Spurious emissions include harmonic emissions, parasitic emissions, inter-modulation products and frequency conversion products, but exclude emissions which result from the modulation process. The necessary bandwidth is defined as twice the transmitted symbol rate.

NOTE 3: Definitions and methods of measurement for integrated equipment are under study.

#### 5.4.5 RF frequency tolerance

RF frequency tolerances are included in the spectrum masks (see figures 3 to 6). The maximum allowable RF frequency tolerance shall not exceed  $\pm 100$  ppm.

### 5.5 Receiver characteristics

#### 5.5.1 Input level range

The input level range for a BER  $< 10^{-3}$  shall extend from the upper limit of -60 dBW to the lower threshold for BER =  $10^{-3}$ , measured at point C.

#### 5.5.2 Spurious emissions

The frequency range in which the spurious emissions specifications apply is 1 GHz to 120 GHz. The limit values measured at point D' are:

$\geq 1$  GHz and  $< 21,2$  GHz: -90 dBW;

$\geq 21,2$  GHz and  $< 80$  GHz: -60 dBW;

$\geq 80$  GHz and  $\leq 120$  GHz: -50 dBW.

NOTE: See notes in subclause 5.4.4.

### 5.6 System performance

#### 5.6.1 BER performance

BER versus receive signal power level referred to point C of the RF block diagram given in figure 1.

See figure 7 for BER performance requirements.

### 5.6.2 Equipment background BER

The equipment background BER level range under simulated operating conditions without interference is measured with a signal level at point C which is between 15 dB and 40 dB above the level which gives  $BER = 10^{-3}$ . The measurement period shall be not less than 15 hours.

For systems less than 34 Mbit/s:  $BER < 10^{-10}$ .

For systems of 34 Mbit/s and above:  $BER < 10^{-11}$ .

All measurements are made at the system bit rate.

### 5.6.3 Interference sensitivity

All receive signals levels and Carrier/Interference (C/I) measurements should be referred to point C of the RF block diagram given in figure 1:

#### a) co-channel interference:

For a receiver operating at the  $10^{-6}$  BER threshold given in figure 7 for system rates of 2 Mbit/s to 155 Mbit/s introduction of a like-modulated co-channel interferer at C/I of 23 dB shall not result in a BER greater than  $10^{-5}$ ;

#### b) adjacent channel interference:

For a receiver operating at the  $10^{-6}$  BER threshold given in figure 7, introduction of a like-modulated adjacent channel interferer at the level and frequency separation given in table 6 shall not result in a BER greater than  $10^{-5}$ ;

#### c) continuous wave spurious interference:

For a receiver operating at the  $10^{-6}$  BER threshold given in figure 7, introduction of a continuous wave interferer at a level of +24 dB or +27 dB, with respect to the "wanted" signal and at any frequency in the range 1 GHz to 120 GHz, excluding frequencies either side of the "wanted" frequency by up to twice the relevant co-polar channel spacing, shall not result in a BER greater than  $10^{-5}$ .

This test is designed to identify specific frequencies at which the receiver may have a spurious response; e.g. image frequency, harmonics of the receive filter, etc. The test is not intended to imply a relaxed specification at all out-of-band frequencies.

**Table 6: Adjacent channel separation and interference levels**

Bit rate (Mbit/s)	Separation of wanted and unwanted signal (MHz)	Carrier/Interference level (dB)
2	14	0
8	28	0
34	56	0
140/155	140	0

### 5.6.4 Distortion sensitivity

Distortion sensitivity is not likely to be significant for short hop operation. Signatures for systems are not required.

## 6 Parameters for wideband analogue systems

### 6.1 Transmit/receive capacity

The following video baseband bandwidths may be used:

- a) up to 3,5 MHz for one hop surveillance, TV or radar;
- b) up to 10 MHz with wide deviation for distribution of broadcast TV;
- c) up to 10 MHz with ITU-R deviation for multi-hop trunks, TV or radar;
- d) up to 14 MHz with ITU-R deviation for multi-hop trunks, TV or radar.

These may have sub-carriers associated with them.

It is recognized that sub-carriers will be used to carry four distinct traffic types:

- continuous wave (e.g. continuity pilot);
- low frequency analogue (e.g. audio);
- wideband analogue (e.g. secondary video);
- data (e.g. 2 Mbit/s).

### 6.2 Applications

The following applications are identified:

- point-to-point television (broadcast quality);
- point-to-point television (surveillance quality);
- point-to-point wideband video (radar remoting).

### 6.3 Baseband parameters

#### 6.3.1 Video interfaces

Level: Nominally 1 V peak-to-peak.

Impedance: 75  $\Omega$  unbalanced.

Minimum return loss: 26 dB.

#### 6.3.2 Audio interface (if applicable)

Level: 0 dBr to 6 dBr (peak level +9 dBm to +15 dBm).

Impedance: Input: 600  $\Omega$  symmetric;  
Output: < 50  $\Omega$  symmetric;  
Minimum return loss: 20 dB.

#### 6.3.3 Digital interface (if applicable)

For CCITT bit rates the interface should conform to the relevant CCITT Recommendation (for example, 2 Mbit/s should conform to CCITT Recommendation G.703 [4]).



**6.3.4 Intermediate Frequency (IF) interface (if applicable)**

The characteristics for any IF interface shall be in accordance with CCIR Recommendation 403 [12].

**6.3.5 Baseband performance**

In view of varied and numerous potential applications for analogue links it is not practical to specify the overall performance characteristics for individual applications.

As an example some sample performance parameters are given in table 7, applicable to an analogue link carrying a Phase Alternate Line (PAL) video signal together with an audio channel.

**Table 7: An example of some performance parameters for a video and an audio channel**

Video:	
Signal to noise - continuous weighted	60 dB
Noise - periodic	-60 dB
Baseband frequency response	±1 dB
Baseband group delay	20 ns
Differential phase	±2°
Differential gain	±2 %
Linear waveform distortion	2 %
Audio:	
Frequency response	±1 dB
Total harmonic distortion	0,5 %
Noise - weighted	60 dBqOps
NOTE:	All measurements made at 40 dB above the receive threshold as defined in subclause 6.6.1.

The absolute performance characteristics for broadcast quality video and audio channels are available in the relevant ITU-T Recommendations (particularly from Study Group 9).

**6.4 Transmitter characteristics**

**6.4.1 Transmitter power range**

Maximum output power up to 0 dBW at point C' of the RF block diagram given in figure 1.

**6.4.2 Transmitter output power tolerance**

The output power tolerance shall be within:

±4 dB: classes 3.3 to 3.5 (defined in subclause 4.3.1.1); and  
(all classes defined in subclause 4.3.1.2);

±3 dB: classes 3.1 and 3.2 (defined in subclause 4.3.1.1).

**6.4.3 Radiated spectrum**

**6.4.3.1 Spectrum masks**

The equipment shall comply with the RF power spectrum masks given in figures 8 and 9. The 0 dB reference level shown on the spectrum masks relates to the peak of the modulated spectrum, and shall be set to the level of the unmodulated carrier. All spectrum masks include an allowance for frequency stability.

**Table 8: Spectrum analyser settings for RF power spectrum measurements**

Video bandwidth (MHz)		< 3,5 MHz	< 14 MHz
Resolution bandwidth	(kHz)	30	30
Total sweep width	(MHz)	50	100
Video filter bandwidth	(kHz)	0,3	0,3
Recommended scan time	(s)	20	40

**6.4.3.2 Frequency deviation**

Frequency deviation is defined in table 9, for:

**a) primary video:**

the primary video may be defined as that traffic not carried on a sub-carrier. No limit applies to the frequency deviation of the primary traffic;

**b) sub-carrier deviation of the main carrier:**

the maximum sub-carrier deviation for each type of traffic is given in table 9 and these limits apply both when the sub-carrier is modulated or unmodulated.

**Table 9: Transmitter characteristics maximum frequency deviations of the main carrier**

Video baseband	< 3,5 MHz	< 6 MHz	< 10 MHz	< 14 MHz
Channel spacing	42 MHz	70 MHz	70 MHz	70 MHz
<b>Maximum frequency deviation of the main carrier</b>				
Primary video	No limit	No limit	No limit	No limit
<b>Sub-carriers:</b>				
- continuous wave (pilot)	0,6 MHz	1 MHz	1 MHz	-
- narrow band analogue (audio)	0,6 MHz	2 MHz	2 MHz	-
- wideband analogue (video)	-	4 MHz	4 MHz	-
- digital	-	2 MHz	2 MHz	-
Spectrum mask	figure 8	figure 9	figure 9	figure 9

**6.4.4 Spurious emissions**

The transmitter shall be unmodulated, and the level of each spurious emission in the frequency range 1 GHz to 120 GHz, shall not exceed:

≥ 1 GHz and < 21,2 GHz: -90 dBW;

≥ 21,2 GHz and < 80 GHz: -60 dBW;

≥ 80 GHz and ≤ 120 GHz: -50 dBW.

NOTE: See notes in subclause 5.4.4.

**6.4.5 RF frequency tolerance**

RF frequency tolerances are included in the spectrum masks (see figures 8 and 9). The maximum allowable RF frequency tolerance shall not exceed ±100 ppm.

## 6.5 Receiver characteristics

All levels refer to point C on block diagram.

### 6.5.1 Input level range

From -50 dBW to receive threshold as defined in subclause 6.6.1.

### 6.5.2 Spurious emissions

The frequency range in which the spurious emissions specifications apply is 1 GHz to 120 GHz. The limit values are:

≥ 1 GHz and < 21,2 GHz: -90 dBW;

≥ 21,2 GHz and < 80 GHz: -60 dBW;

≥ 80 GHz and ≤ 120 GHz: -50 dBW.

NOTE: See notes in subclause 5.4.4.

### 6.5.3 Noise figure

The receiver noise figure shall not exceed 15 dB.

## 6.6 Transmit/receive performance

### 6.6.1 Receiver threshold

The receiver threshold is defined as the receive signal level (referred to point C of the RF block diagram given in figure 1 at which a certain minimum performance is reached. In view of the wide variety of equipment types to be found in practice it is not proposed to state limits for this parameter. However in order to specify meaningful interference limits it is necessary to use the measured receiver threshold as a baseline.

The receiver threshold is defined in terms of the Frequency Modulation (FM) threshold of the equipment. The signal/unweighted noise ratio shall be measured at each output port (video, audio, etc.) as a function of receive signal level. The receiver threshold shall be defined as the receiver level at which the relationship between the receive signal level and the output signal/noise ratio deviates by 3 dB. It is recognized that for a composite video signal (incorporating modulated sub-carriers) the threshold will be different for each output signal, the receiver threshold in this case should be taken as the highest receive signal level at which any of the output signals reaches the FM threshold.

### 6.6.2 Interference sensitivity

#### a) Co-channel interference:

For planning purposes it should be assumed that the level of co-channel interference into the wideband analogue channel should not exceed -125 dBW. It should be recognized that the degradation in performance caused by this interference will depend on a number of equipment characteristics (e.g. deviation, receiver noise performance, etc.) and, therefore, it is not proposed to set limits on this parameter. However, it is desirable to measure and record the co-channel interference level;

#### b) adjacent channel interference:

For a receiver operating with a "wanted" signal whose level is 9 dB above the receiver threshold measured in subclause 6.6.1, the introduction at point C of a like modulated interferer at the level and frequency separation given in table 10 shall not result in a degradation of the output signal/noise ratio of more than 1 dB.

Table 10: Adjacent channel separation and interference levels

Video bandwidth (MHz)	Separation of wanted and interfering signal (MHz)	Carrier/Interference level (dB)
< 3,5 MHz	42	0
< 6 MHz	70	0
< 10 MHz	70	0
< 14 MHz	70	0

**c) continuous wave spurious interference:**

For a receiver operating with a "wanted" signal whose level is 9 dB above the receiver threshold measured in subclause 6.6.1, the introduction at point C of a continuous wave interferer at a level of +30 dB with respect to the "wanted" signal and at any frequency from 1 GHz to 120 GHz, excluding frequencies either side of the wanted signal by up to twice the relevant co-polar spacing, shall not result in a degradation of any output signal/noise ratio of more than 1 dB.

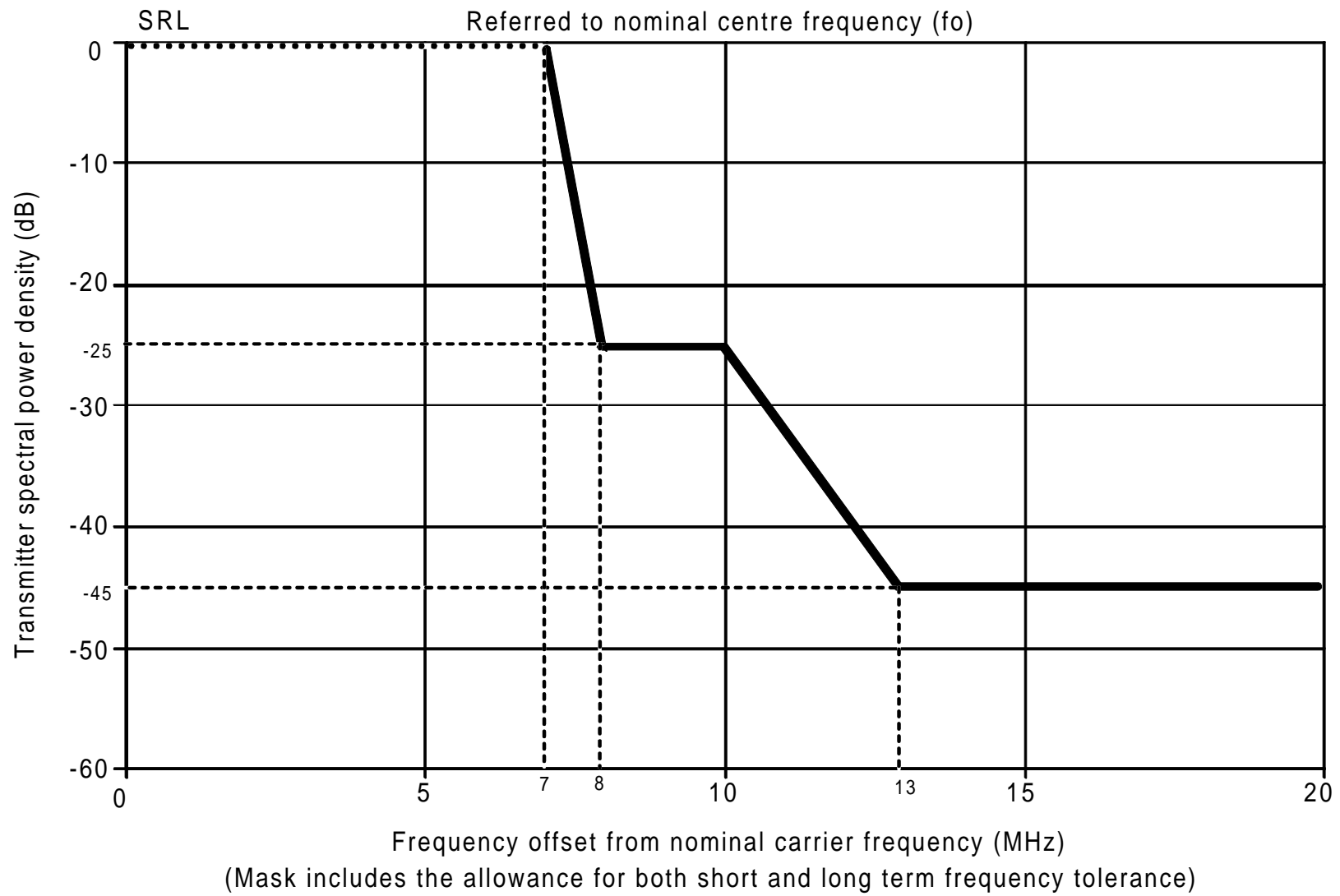

Figure 3: Limits of spectral power density for minimum system rate of 2 Mbit/s using channel spacing of 14 MHz

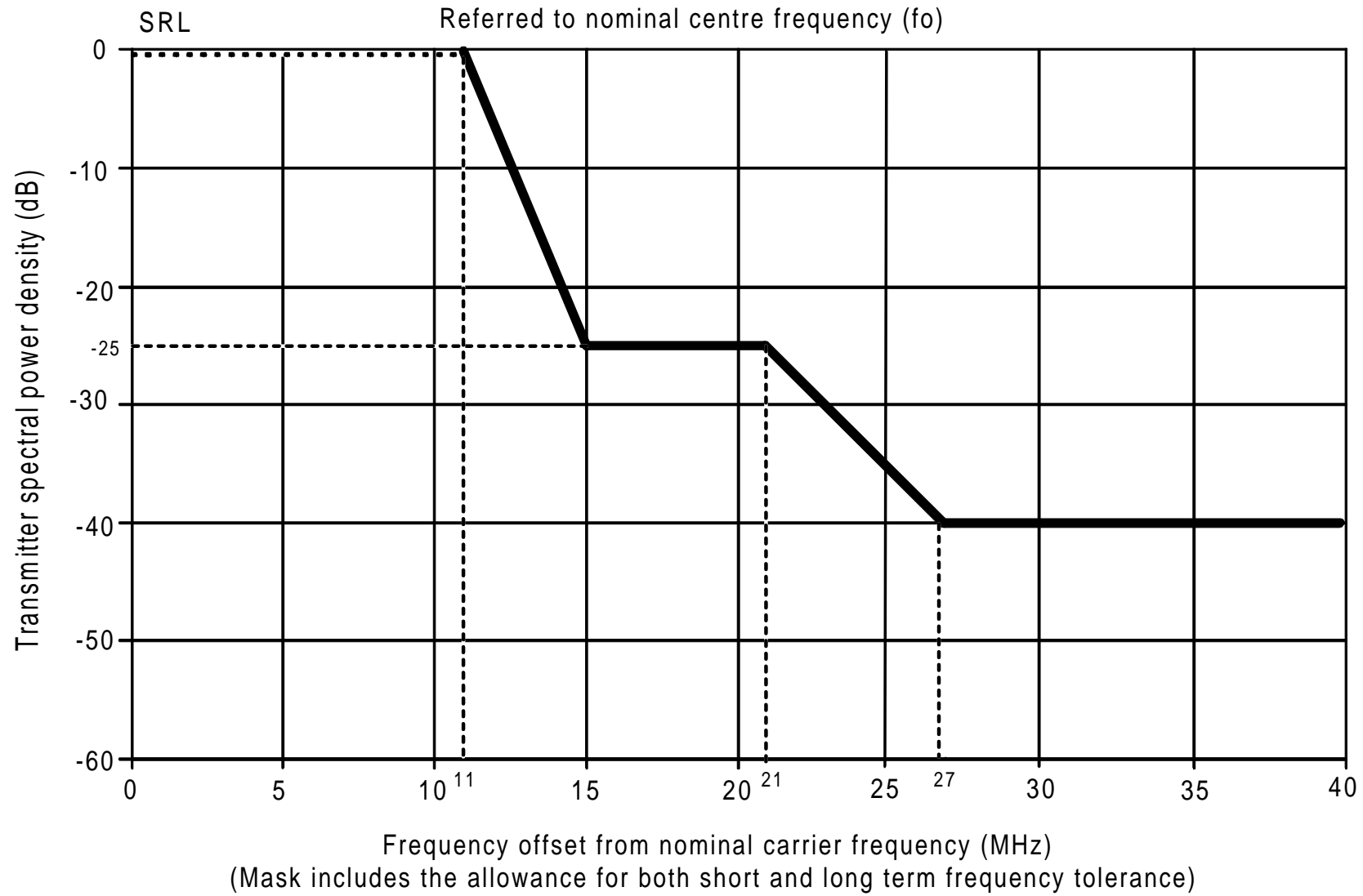

Figure 4: Limits of spectral power density for minimum system rate of 8 Mbit/s using channel spacing of 28 MHz

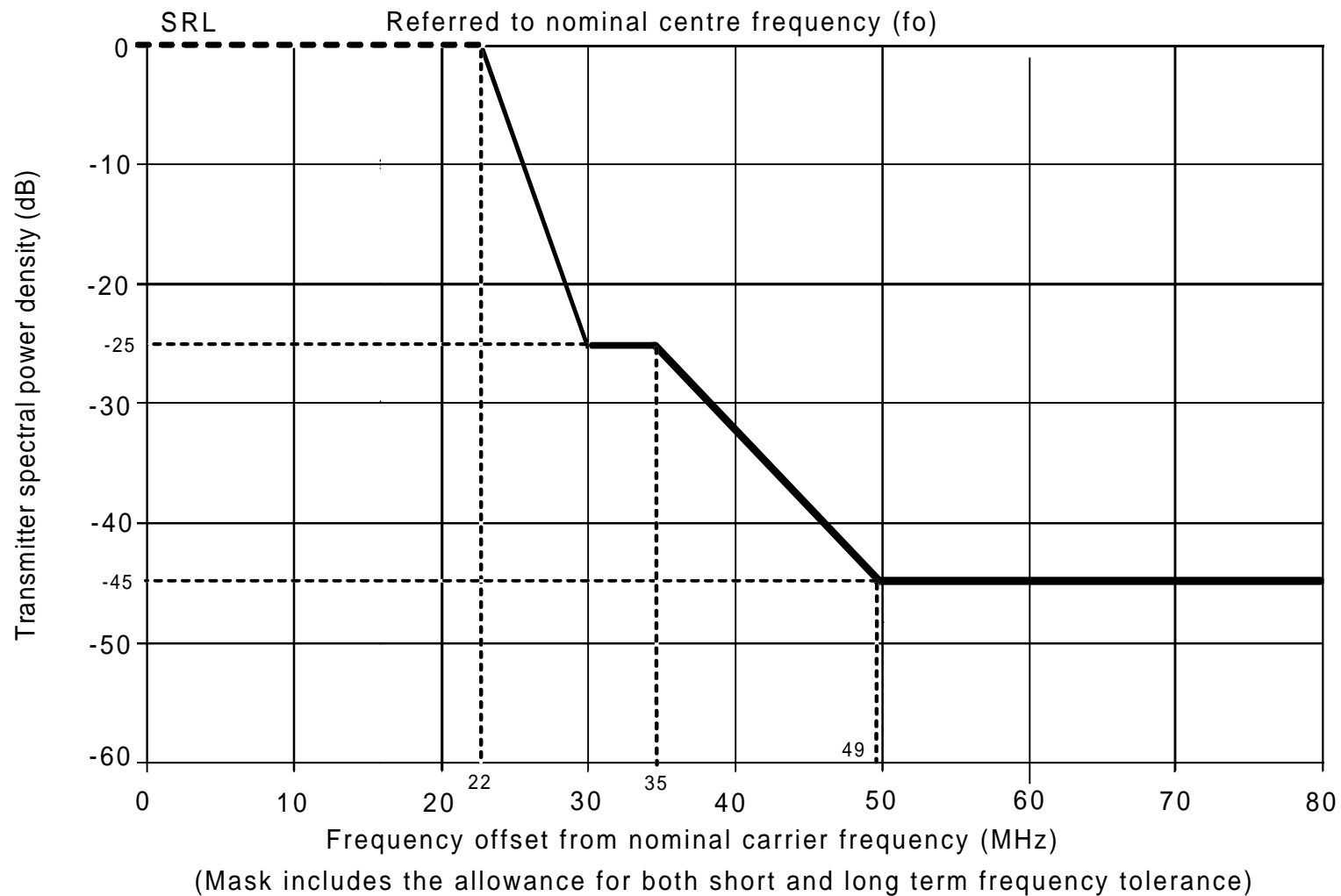

Figure 5: Limits of spectral power density for minimum system rate of 34 Mbit/s using channel spacing of 56 MHz

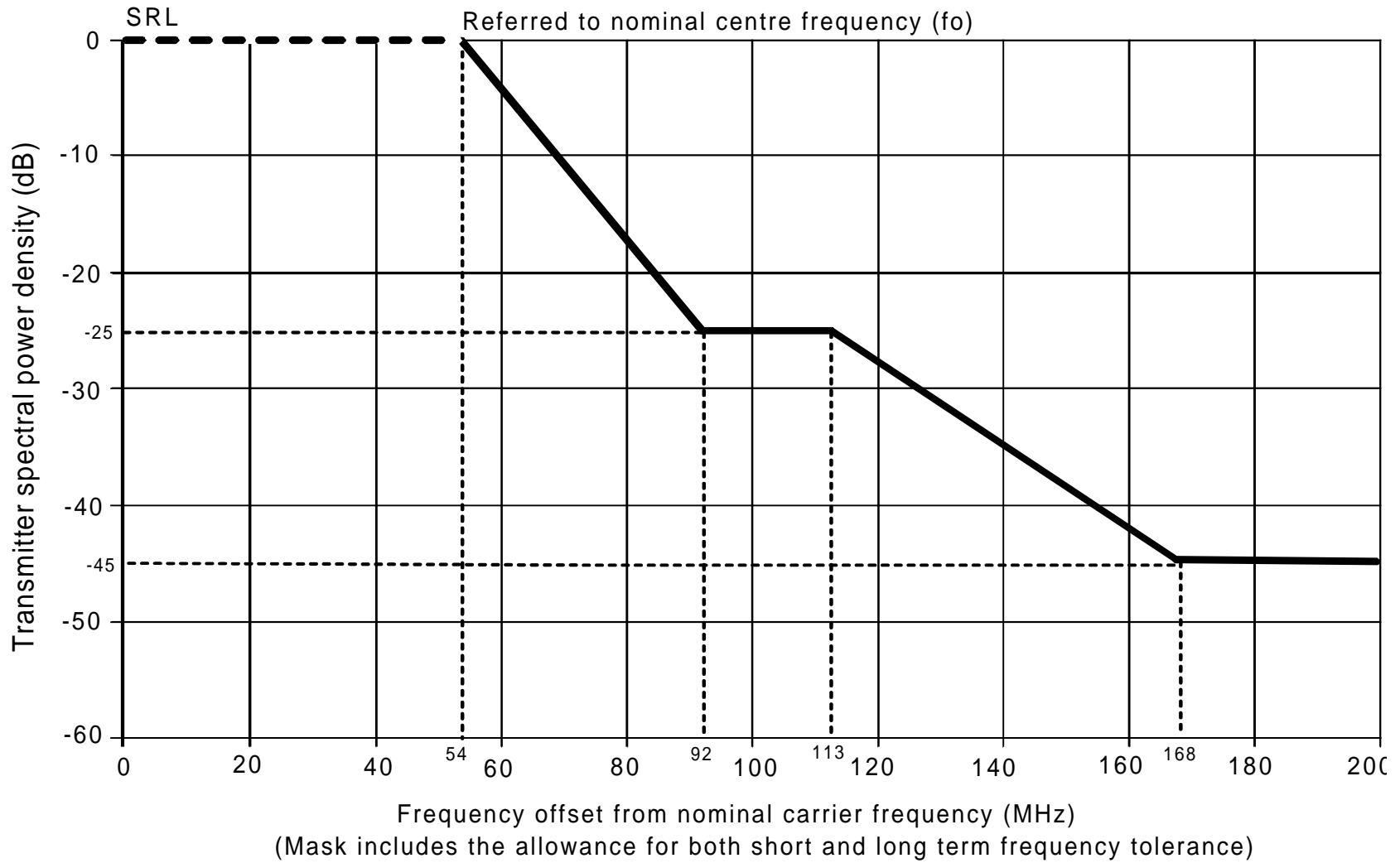
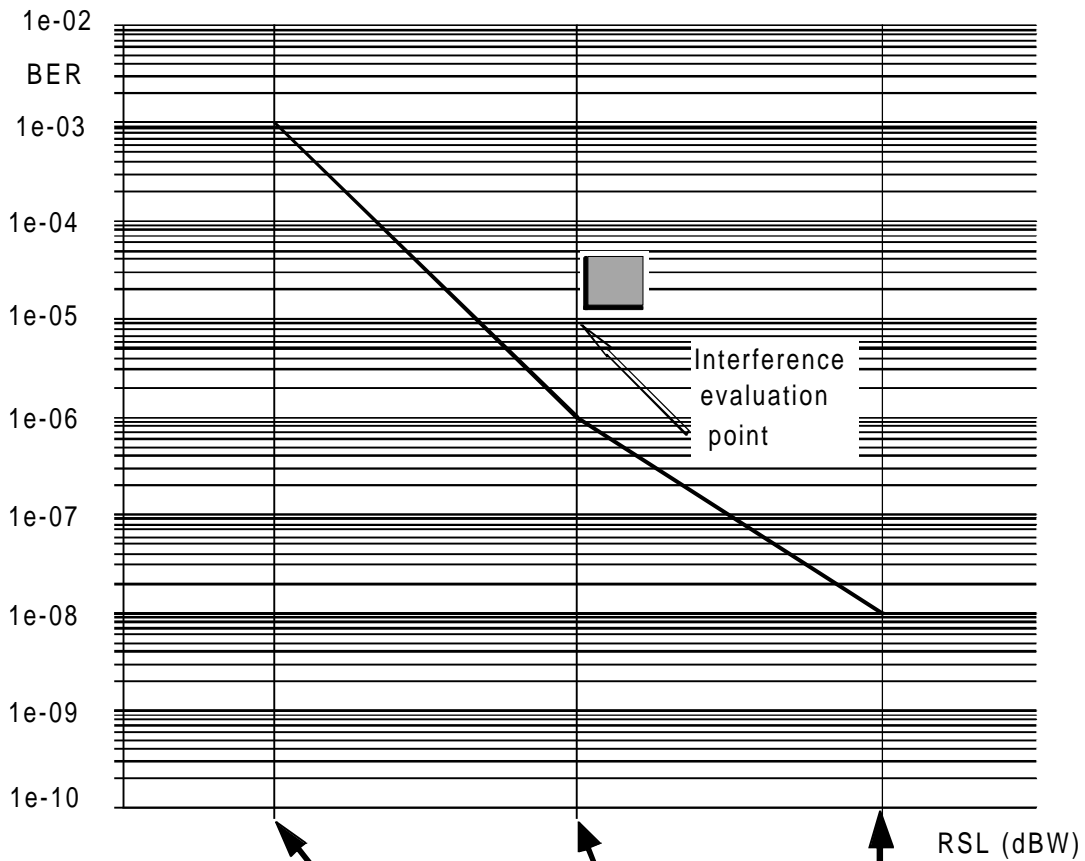

Figure 6: Limits of spectral power density for minimum system rate of 140/155 Mbit/s using channel spacing of 140 MHz





	BER 1e-3	BER 1e-6	BER 1e-8
2 Mbit/s	- 79	- 75	- 72
8 Mbit/s	- 73	- 69	- 66
34 Mbit/s	- 64 (NOTE)	- 60 (NOTE)	- 57 (NOTE)
140/155 Mbit/s	- 58 (NOTE)	- 54 (NOTE)	- 51 (NOTE)

NOTE: In the future, it may be necessary to review these levels, due to advances in technology.

**Figure 7: Bit Error Rate (BER) versus Receiver Signal Level (RSL)**

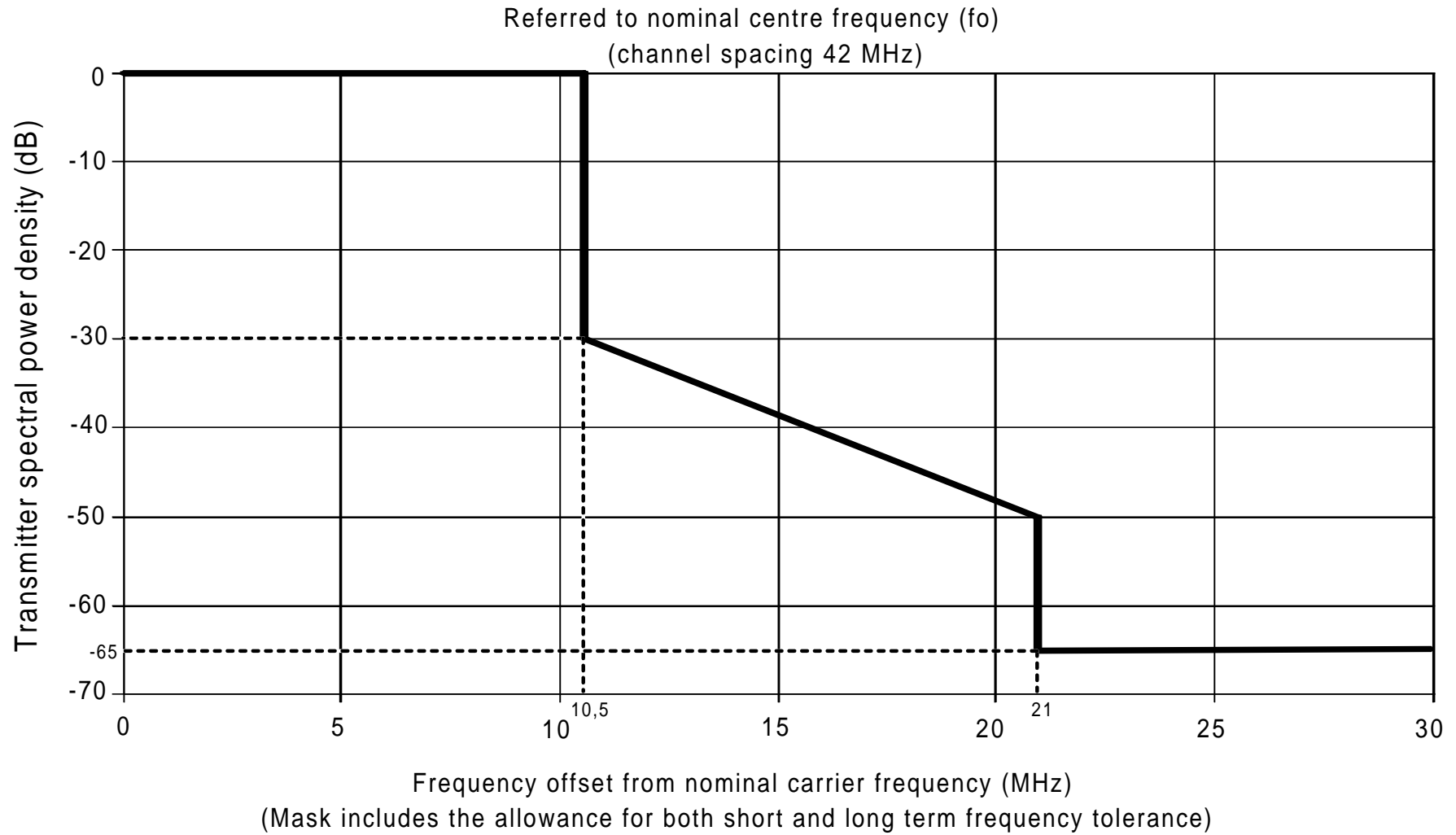
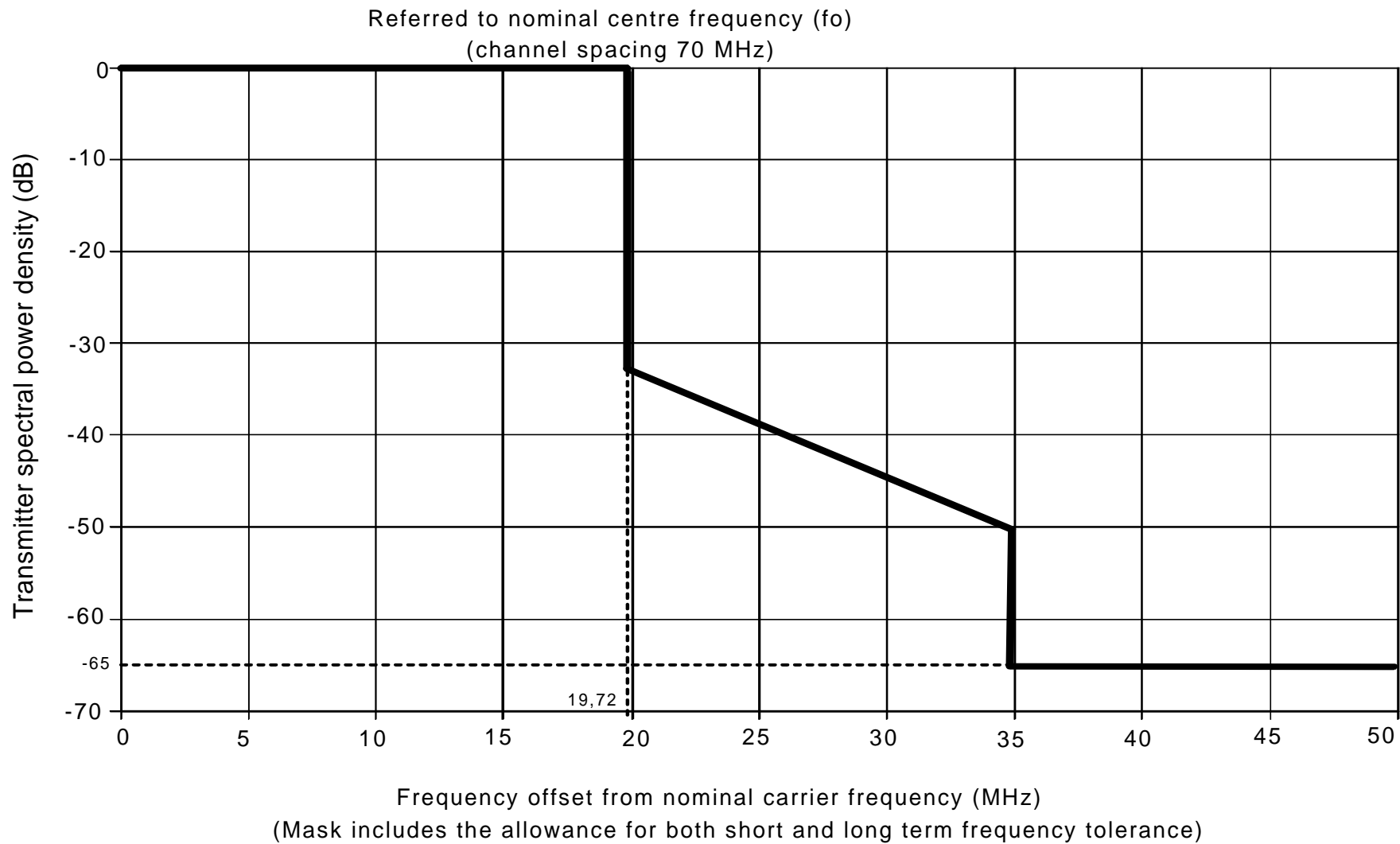

Figure 8: Limits of spectral power density for video basebands up to 3,5 MHz



**Figure 9: Limits of spectral power density for video basebands up to 14 MHz**

## **Annex A (informative): Additional information**

### **A.1 Performance prediction and objectives**

For medium grade performance the objectives should be to comply with class 4 digital section ITU-R Recommendation F.696-1 [15].

For local grade performance reference should be made to ITU-R Recommendation F.697-1 [16] and CCIR Report 1053 [20].

The dominant fading mechanism is rain attenuation; performance prediction methods should be based on the following documents:

- for calculation of rain attenuation and outage:
  - CCIR Report 338 [17];
  - CCIR Report 721 [19];
- for rain rates:
  - CCIR Report 563 [18].

NOTE: This information should be considered as preliminary.

## History

Document history			
March 1994	Public Enquiry	PE 59:	1994-03-21 to 1994-08-12
December 1996	Vote	V 117:	1996-12-23 to 1997-02-14
March 1997	First Edition		