

<i>BLUETOOTH</i> DOC	Date / Year-Month-Day 2007-04-16	Approved Adopted	Revision V12	Document No AVDTP_SPEC
Prepared Audio Video WG	e-mail address avv-feedback@bluetooth.org			N.B.

AUDIO/VIDEO DISTRIBUTION TRANSPORT PROTOCOL SPECIFICATION

Abstract

This protocol defines A/V stream negotiation, establishment, and transmission procedures. Also specified are the message formats that are exchanged between such devices to transport their A/V streaming in A/V distribution applications.

Revision History

Revision	Date	Comments
Draft 0.95a	February 2002	Updated with Internal Feedback
Draft 0.95b	March 2002	Release after Adoption Review
Draft 1.00	May 2002	Release for Voting Draft
Draft 1.00b	February 2003	Release for Voting Draft
Version 1.0	May 2003	Updated title and header
Version 1.1	August 2003	Updated for Bluetooth v1.2
Version 1.1 RC2	October 2003	Update after Review Included Approved Errata (only editorial or clarifying changes)
D12r00	15 Aug 2005	Updated for core release v1.2 or later
D12r01	13 Sept 2005	Editorial updates
D12r02	27 Oct 2005	Editorial updates
D12r03	10 Nov 2005	Editorial updates
D12r04	30 Nov 2005	Editorial updates

Contributors

Name	Company
Morgan Lindqvist	Ericsson
Michael Andre	Intel
Tsuyoshi Okada	Matsushita
Billy Brackenridge	Microsoft
Jurgen Schnitzler	Nokia
Kalervo Kontola	Nokia
Vesa Lunden	Nokia
Christian Bouffieux	Philips
Emmanuel Mellery	Philips
Geert Knapen	Philips
Marc Vauclair	Philips
Olivier Hus	Philips
Rob J. Davies	Philips
Shaun Barrett	Philips
Harumi Kawamura	Sony
Masakazu Hattori	Sony
Ruediger Mosig	Sony
Ichiro Tomoda	Toshiba
Junko Ami	Toshiba
Takeshi Saito	Toshiba
Yoshiaki Takabatake	Toshiba

Disclaimer and Copyright Notice

The copyright in this specification is owned by the Promoter Members of *Bluetooth*® Special Interest Group (SIG), Inc. ("*Bluetooth* SIG"). Use of these specifications and any related intellectual property (collectively, the "Specification"), is governed by the Promoters Membership Agreement among the Promoter Members and *Bluetooth* SIG (the "Promoters Agreement"), certain membership agreements between *Bluetooth* SIG and its Adopter and Associate Members (the "Membership Agreements") and the *Bluetooth* Specification Early Adopters Agreements (1.2 Early Adopters Agreements) among Early Adopter members of the unincorporated *Bluetooth* SIG and the Promoter Members (the "Early Adopters Agreement"). Certain rights and obligations of the Promoter Members under the Early Adopters Agreements have been assigned to *Bluetooth* SIG by the Promoter Members.

Use of the Specification by anyone who is not a member of *Bluetooth* SIG or a party to an Early Adopters Agreement (each such person or party, a "Member"), is prohibited. The legal rights and obligations of each Member are governed by their applicable Membership Agreement, Early Adopters Agreement or Promoters Agreement. No license, express or implied, by estoppel or otherwise, to any intellectual property rights are granted herein.

Any use of the Specification not in compliance with the terms of the applicable Membership Agreement, Early Adopters Agreement or Promoters Agreement is prohibited and any such prohibited use may result in termination of the applicable Membership Agreement or Early Adopters Agreement and other liability permitted by the applicable agreement or by applicable law to *Bluetooth* SIG or any of its members for patent, copyright and/or trademark infringement.

THE SPECIFICATION IS PROVIDED "AS IS" WITH NO WARRANTIES WHATSOEVER, INCLUDING ANY WARRANTY OF MERCHANTABILITY, NONINFRINGEMENT, FITNESS FOR ANY PARTICULAR PURPOSE, SATISFACTORY QUALITY, OR REASONABLE SKILL OR CARE, OR ANY WARRANTY ARISING OUT OF ANY COURSE OF DEALING, USAGE, TRADE PRACTICE, PROPOSAL, SPECIFICATION OR SAMPLE.

Each Member hereby acknowledges that products equipped with the *Bluetooth* technology ("*Bluetooth* products") may be subject to various regulatory controls under the laws and regulations of various governments worldwide. Such laws and regulatory controls may govern, among other things, the combination, operation, use, implementation and distribution of *Bluetooth* products. Examples of such laws and regulatory controls include, but are not limited to, airline regulatory controls, telecommunications regulations, technology transfer controls and health and safety regulations. Each Member is solely responsible for the compliance by their *Bluetooth* Products with any such laws and regulations and for obtaining any and all required authorizations, permits, or licenses for their *Bluetooth* products related to such regulations within the applicable jurisdictions. Each Member acknowledges that nothing in the Specification provides any information or assistance in connection with securing such compliance, authorizations or licenses. **NOTHING IN THE SPECIFICATION CREATES ANY WARRANTIES, EITHER EXPRESS OR IMPLIED, REGARDING SUCH LAWS OR REGULATIONS.**

ALL LIABILITY, INCLUDING LIABILITY FOR INFRINGEMENT OF ANY INTELLECTUAL PROPERTY RIGHTS OR FOR NONCOMPLIANCE WITH LAWS, RELATING TO USE OF THE SPECIFICATION IS EXPRESSLY DISCLAIMED. BY USE OF THE SPECIFICATION, EACH MEMBER EXPRESSLY WAIVES ANY CLAIM AGAINST *BLUETOOTH* SIG AND ITS PROMOTER MEMBERS RELATED TO USE OF THE SPECIFICATION.

Bluetooth SIG reserve the right to adopt any changes or alterations to the Specification as it deems necessary or appropriate.

Copyright © 2001 –2007. *Bluetooth* SIG Inc. All copyrights in the Bluetooth Specifications themselves are owned by Agere Systems Inc., Ericsson AB, Lenovo, Intel Corporation, Microsoft Corporation, Motorola, Inc., Nokia Corporation and Toshiba Corporation. *Other third-party brands and names are the property of their respective owners.

Document Terminology

The Bluetooth SIG has adopted Section 13.1 of the IEEE Standards Style Manual, which dictates use of the words ``shall'', ``should'', ``may'', and ``can'' in the development of documentation, as follows:

- The word *shall* is used to indicate mandatory requirements strictly to be followed in order to conform to the standard and from which no deviation is permitted (*shall* equals *is required to*).
- The use of the word *must* is deprecated and shall not be used when stating mandatory requirements; *must* is used only to describe unavoidable situations.
- The use of the word *will* is deprecated and shall not be used when stating mandatory requirements; *will* is only used in statements of fact.
- The word *should* is used to indicate that among several possibilities one is recommended as particularly suitable, without mentioning or excluding others; or that a certain course of action is preferred but not necessarily required; or that (in the negative form) a certain course of action is deprecated but not prohibited (*should* equals *is recommended that*).
- The word *may* is used to indicate a course of action permissible within the limits of the standard (*may* equals *is permitted*).

The word *can* is used for statements of possibility and capability, whether material, physical, or causal (*can* equals *is able to*).

Contents

1	General Description	10
1.1	Overview	10
1.2	Operation between Devices	11
2	A/V Distribution Stack Overview	12
2.1	Architectural Functionality	12
2.2	Architectural Interfaces	13
3	Functional Requirements	14
4	Terminology and Definitions	15
4.1	Stream	15
4.2	Source (SRC) and Sink (SNK)	15
4.3	Initiator (INT) and Acceptor (ACP)	15
4.4	Application and Transport Service Capabilities	15
4.5	Services, Service Categories, and Service Parameters	16
4.6	Media Packets, Recovery Packets, and Reporting Packets	16
4.7	Stream End Point (SEP)	16
4.8	Stream Context (SC)	16
4.9	Stream Handle (SH)	17
4.10	Stream End Point Identifier (SEID)	17
4.11	Stream End Point State	17
4.12	Transport Session	17
4.13	Transport Session Identifier (TSID)	18
4.14	Transport Channel	18
4.15	Transport Channel Identifier (TCID)	18
4.16	Reserved for Future Additions (RFA)	19
4.17	Reserved for Future Definitions (RFD)	19
4.18	Forbidden (F)	19
5	Architecture	20
5.1	Block Functionality	20
5.1.1	Stream Manager	20
5.1.2	Recovery	21
5.1.3	Adaptation Layer	21
5.2	Interface Functionality	21
5.3	Stream End Point Architecture	22
5.4	Transport Services	23
5.4.1	Basic Service	23
5.4.2	Recovery Service	24
5.4.3	Reporting Service	25
5.4.4	Adaptation Service – Multiplexing	26
5.4.5	Adaptation Service – Robust Header Compression	27
5.4.6	Transport and Signaling Channel Establishment	28
6	Signaling Procedures	29
6.1	General Requirements	29
6.2	Transaction Model	29
6.3	Stream Management Signaling Overview	30
6.4	Signal Command Set	32
6.5	State Machine Overview	32
6.6	Stream End Point Discovery	33
6.7	Get capabilities	33
6.8	Stream Configuration	33
6.9	Stream Get Configuration	34
6.10	Stream Establishment	35
6.11	Stream Start	36
6.12	Stream Release	37

Audio/Video Distribution Transport Protocol (AVDTP)

6.13	Stream Suspend.....	37
6.14	Stream Reconfigure.....	38
6.15	Security Control.....	39
6.16	Abort.....	39
6.17	General Reject.....	40
7	Transport Procedures.....	41
7.1	General Requirements.....	41
7.2	Basic Service.....	41
7.2.1	Media Packet Format.....	41
7.3	Reporting Service.....	44
7.3.1	Sender Report Reporting packet (SR).....	44
7.3.2	Receiver report packet (RR).....	47
7.3.3	Source description packet (SDS).....	47
7.3.4	Reporting Feedback.....	48
7.4	Recovery Service.....	48
7.4.1	Scope.....	48
7.4.2	Overview.....	49
7.4.3	Recovery transport channel.....	50
7.4.4	RTP payload type.....	50
7.4.5	Session Description Protocol (SDP) requirements.....	50
7.4.6	Real Time Streaming Protocol (RTSP) requirements.....	50
7.4.7	Parity codes.....	50
7.4.8	Recovery Window.....	51
7.4.9	Recovery SEP capabilities.....	51
7.4.10	Applicable coding schemes.....	51
7.4.11	Unsystematic coding schemes.....	52
7.5	Multiplexing Service.....	52
7.5.1	Adaptation Layer PDU packet format.....	52
7.5.2	Adaptation Layer Header format.....	53
7.5.3	Adaptation Layer Fragmentation.....	54
7.6	Robust Header Compression Service.....	55
7.6.1	CRC Calculation.....	55
7.6.2	Per-Channel Parameters.....	55
7.6.3	Feedback Channel.....	55
7.6.4	Packet Types.....	55
8	Signaling Messages.....	56
8.1	Stream Configuration Procedure.....	56
8.2	Signaling Message format.....	56
8.3	Signal Fragmentation.....	57
8.4	Signal command and response headers.....	58
8.4.1	Transaction Label.....	58
8.4.2	Packet Type.....	59
8.4.3	Message Type.....	59
8.4.4	Signal Identifier.....	59
8.4.5	Packet size requirements.....	59
8.4.6	Message integrity verification at receiver side.....	60
8.5	Signaling command set.....	60
8.6	Stream End Point Discovery.....	61
8.6.1	Stream End Point Discovery Command.....	61
8.6.2	Stream End Point Discovery Response.....	61
8.6.3	Stream End Point Discovery Reject.....	61
8.7	Get Capabilities.....	61
8.7.1	Get Capabilities Command.....	61
8.7.2	Get Capabilities Response.....	62
8.7.3	Get Capabilities Reject.....	62
8.8	Stream Configuration.....	62

8.8.1	Set Configuration Command.....	62
8.8.2	Set Configuration Response.....	63
8.8.3	Set Configuration Reject.....	63
8.9	Get Stream configuration.....	63
8.9.1	Get Configuration Command.....	63
8.9.2	Get Configuration Response.....	64
8.9.3	Get Configuration Reject.....	64
8.10	Stream Reconfigure.....	64
8.10.1	Reconfigure Command.....	64
8.10.2	Reconfigure Response.....	65
8.10.3	Reconfigure Reject.....	65
8.11	Stream Establishment.....	65
8.11.1	Open Stream Command.....	66
8.11.2	Open Stream Response.....	66
8.11.3	Open Stream Reject.....	66
8.12	Stream Start.....	67
8.12.1	Start Stream Command.....	67
8.12.2	Start Stream Response.....	67
8.12.3	Start Stream Reject.....	67
8.13	Stream Release.....	68
8.13.1	Close Stream Command.....	68
8.13.2	Close Stream Response.....	68
8.13.3	Close Stream Reject.....	68
8.14	Stream Suspend.....	69
8.14.1	Suspend Command.....	69
8.14.2	Suspend Response.....	69
8.14.3	Suspend Reject.....	69
8.15	Abort.....	70
8.15.1	Abort Command.....	70
8.15.2	Abort Response.....	70
8.16	Security Control.....	70
8.16.1	Security Control Command.....	70
8.16.2	Security Control Response.....	70
8.16.3	Security Control Reject.....	71
8.17	General Reject.....	71
8.18	Information Elements.....	71
8.18.1	Stream End-point IDentifier (SEID, INT SEID, ACP SEID).....	71
8.18.2	Length of Service Capability (LOSC).....	72
8.18.3	Stream End-point Type, Source or Sink (TSEP).....	72
8.18.4	Number of Signal Packets (NOSP).....	72
8.18.5	Stream End Point in Use (In Use).....	72
8.18.6	Signaling Errors (ERROR_CODE).....	72
8.19	Service Capabilities.....	78
8.19.1	Generic Service Capabilities information elements.....	78
8.19.2	Media Transport Capabilities.....	79
8.19.3	Reporting Capabilities.....	80
8.19.4	Recovery Capabilities.....	80
8.19.5	Media Codec Capabilities.....	81
8.19.6	Content Protection Capabilities.....	81
8.19.7	Header Compression Capabilities.....	81
8.19.8	Multiplexing Capabilities.....	82
9	State Diagrams.....	85
9.1	State Definitions.....	85
9.2	Collect Capabilities.....	85
9.3	Stream Configuration.....	86
9.4	Connection Establishment.....	87

9.5	Start Streaming.....	88
9.5.1	INT is a SNK Device	88
9.5.2	INT is a SRC Device	88
9.6	Connection Release - Open/Streaming.....	89
9.7	Stream Suspend.....	90
9.8	Stream Change Parameters.....	91
9.9	Abort Stream.....	92
9.10	Content Security	93
9.11	INT/ACP State Inconsistency	93
10	References.....	94
11	List of Figures.....	95
12	List of Tables.....	98
13	APPENDIX A – AVDTP Upper Interface.....	99
13.1	Signaling Interface.....	99
13.1.1	Event Registration service call.....	99
13.1.2	Connect Request	105
13.1.3	Connect Response.....	106
13.1.4	Disconnect Request.....	107
13.1.5	Stream Discover Request.....	107
13.1.6	Stream Discover Response	108
13.1.7	Stream Get Capabilities Request.....	108
13.1.8	Stream Get Capabilities Response.....	109
13.1.9	Set Configuration Request.....	109
13.1.10	Set Configuration Response	110
13.1.11	Get Configuration Request	111
13.1.12	Get Configuration Response.....	111
13.1.13	Open Stream Request	112
13.1.14	Open Stream Response	113
13.1.15	Close Stream Request.....	113
13.1.16	Close Stream Response	114
13.1.17	Start Stream Request	114
13.1.18	Start Stream Response.....	115
13.1.19	Suspend Request.....	115
13.1.20	Suspend Response.....	116
13.1.21	Reconfigure Request	116
13.1.22	Reconfigure Response	117
13.1.23	Security Control Request	118
13.1.24	Security Control Response	118
13.1.25	Abort Request	119
13.1.26	Abort Response	120
13.2	Media Transport service interface	120
13.2.1	Write Stream Data.....	120
13.2.2	Read Stream Data	121
14	APPENDIX B – Multiplexing Service Example (informative)	123
14.1	Packetisation in Basic Service Mode	123
14.2	Packetisation in Multiplexing Mode	123
15	APPENDIX C – Content Protection Procedure (informative).....	125
16	APPENDIX D – Transport and Streaming Considerations (informative)	126
16.1	Synchronisation Definitions	126
16.1.1	Clock Synchronization	126
16.1.2	Intra-Stream Synchronization	126
16.1.3	Inter-Stream Synchronization	127
16.1.4	Indirect Inter-Stream Synchronization.....	128
16.2	Different clocks and Synchronisation	128
16.3	RTP timestamp and Sequence Numbers.....	128
16.4	Jitter Calculations	128

16.5	Media Stream Service Interface	129
17	APPENDIX E - Acronyms and Abbreviations	130

1 General Description

1.1 Overview

This document specifies the transport protocol for audio and/or video distribution connections and streaming of audio or video media over the Bluetooth air interface. Audio and video data streams require isochronous data transmission capability.

The transport mechanism and message formats of the A/V Distribution Transport Protocol (hereinafter referred to as AVDTP) are based on RTP defined in [3], which consists of two major protocols: RTP Data Transfer Protocol (RTP) and RTP Control Protocol (RTCP). This document, A/V Distribution Transport Protocol Specification, defines the RTP protocol usage mechanism on ACL links that apply to L2CAP connections.

Commands and responses for executing the stream set-up procedures are defined as Bluetooth specific. AVDTP defines the binary transactions between Bluetooth devices for stream set-up and media streaming for audio and video using L2CAP.

A/V streaming and stream set-up signaling are transported via L2CAP packets. A dedicated Protocol/Service Multiplexer (PSM) value is used to identify L2CAP packets that are intended for AVDTP.

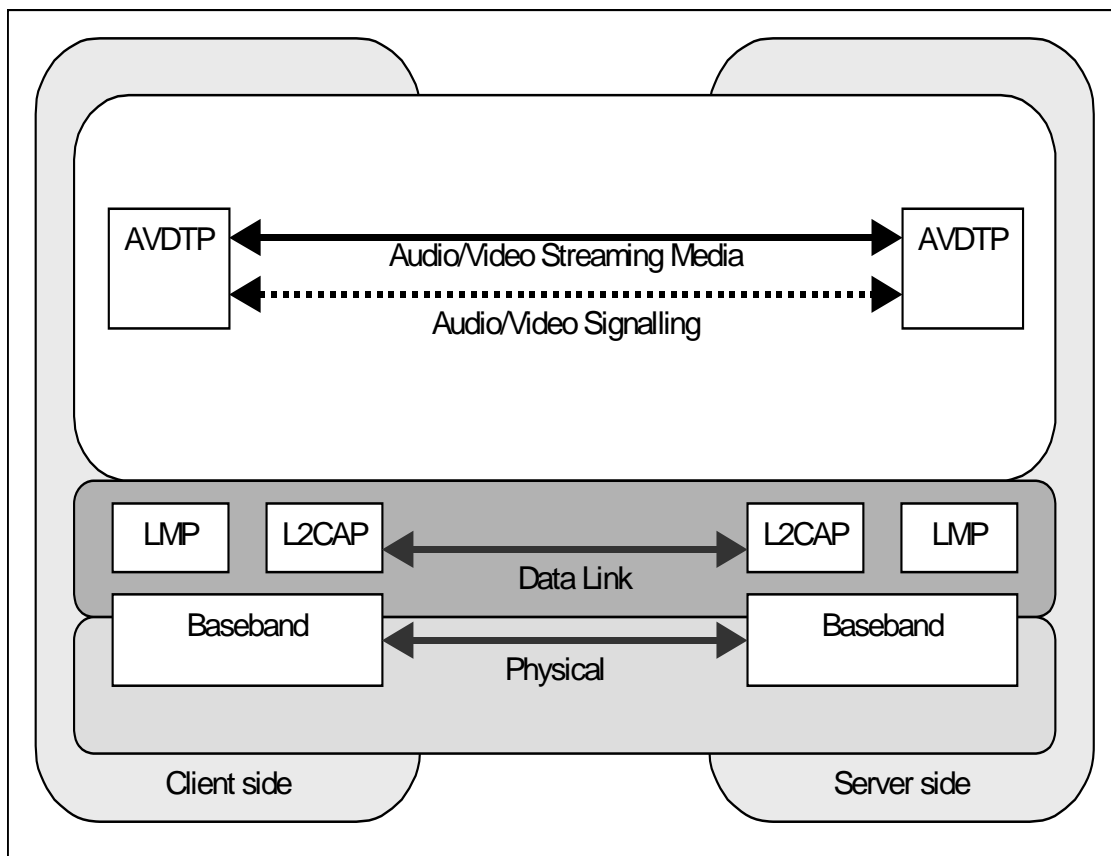

Figure 1.1: AVDTP and Bluetooth Protocol Stack

1.2 Operation between Devices

AVDTP applies point-to-point signaling over a connection-oriented L2CAP channel. The L2CAP channel is set up in advance, between two devices participating in A/V stream data distribution. L2CAP channels are best suited for the support of A/V stream data distribution links. This is because L2CAP channels **can** be flexibly configured to enable bandwidth to be shared between A/V content streams. A/V streams are transported in pseudo-isochronous L2CAP channels. A/V signaling is also transported via L2CAP channels. Signaling provides stream discovery, configuration, establishment, and transfer control.

2 A/V Distribution Stack Overview

Figure 2.1 shows how AVDTP, Bluetooth protocol stack, and upper layer integrate together. AVDTP exposes three interfaces to the upper layer and two interfaces to the Bluetooth protocol stack. In order to retrieve A/V device details the upper layer uses the SDP interface, provided by the Bluetooth protocol stack. Architectural interfaces are described in Section 2.2 and architectural functionality is described in Section 2.1.

When A/V applications transport audio and/or video streams over Bluetooth links, AVDTP performs A/V parameter negotiation. Based on the result of this negotiation, A/V applications transport audio and/or video content.

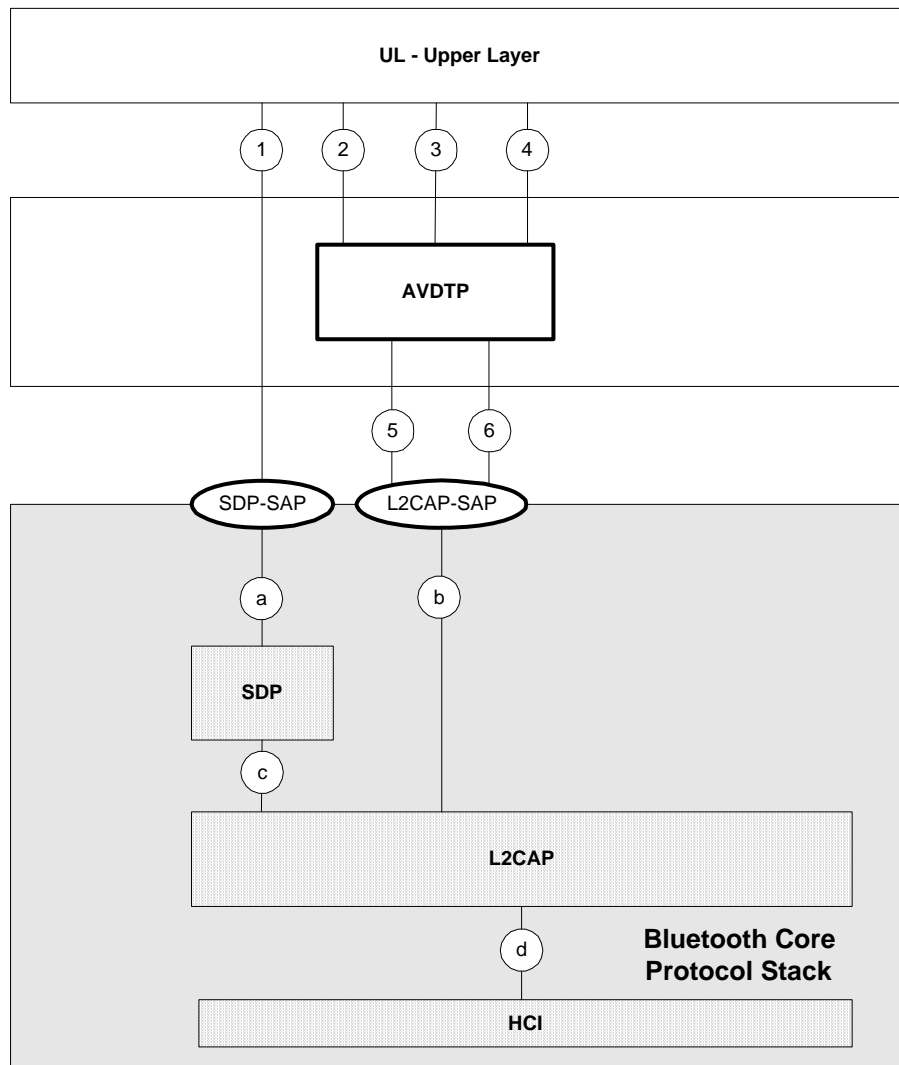

Figure 2.1: A/V Architecture Block Diagram

2.1 Architectural Functionality

With reference to Figure 2.1, the A/V architecture consists of the following architectural blocks:

Block	Description
Upper Layer	Upper Layer requiring AVDTP services
AVDTP	Audio Video Distribution Transport Protocol
SDP	Service Discovery Protocol [1]
Bluetooth Protocol Stack	See [1]

Table 2.1: A/V Architectural Functionality

2.2 Architectural Interfaces

With reference to Figure 2.1, the A/V architecture exposes the following interfaces:

Interface	Description
1	Service Discovery Protocol (SDP) message interface used to discover the Bluetooth attributes from a distant device.
2	Application interface used to exchange Reporting packets of the stream between two interconnected devices (QoS reporting).
3	Interface that is used to exchange signaling messages between two interconnected devices for stream set-up phases, reconfiguring and tear down streams. The purpose of this channel is to provide channel negotiation in A/V distribution applications.
4	A/V elementary media packets that transport the audio/video content over one or several L2CAP connection-oriented channels during an A/V distribution session between two Bluetooth devices. The media packet format is defined at profile level.
5	L2CAP channel allocated for AVDTP signaling. L2CAP channels are distinguished by the first level of protocol routing PSM value = AVDTP.
6	L2CAP channels allocated for AVDTP transport of Media packets, Recovery packets, and Reporting packets. L2CAP channels are distinguished by the first level of protocol routing PSM value = AVDTP.
a to d	See [1]

Table 2.2: A/V Architectural Interfaces

3 Functional Requirements

The following capabilities have been identified as requirements of the A/V Distribution Transport Protocol.

1. **AVDTP shall** provide the means to discover the capabilities of the devices, as well as the means to negotiate for A/V stream set up.
2. **AVDTP shall** provide the mechanism to establish and tear down a stream.
3. **AVDTP shall** provide for the mechanism and the message formats for real-time streams, which are:
 - Mechanisms to minimize the transmission delay
 - Mechanisms to attach data that provides timing information required for playback of media streams on the receiver side
 - Mechanisms for reporting the Quality of Service and status of transport of Media packets to application level
 - Mechanisms to optimize the use of available bandwidth
4. **AVDTP shall** be flexible by its independent functions for use on devices of limited complexity.
5. **AVDTP shall** provide recovery mechanisms.
6. **AVDTP shall** provide mechanisms to reduce the overhead of the headers in the transport protocol

4 Terminology and Definitions

4.1 Stream

A **stream** (Bluetooth A/V Stream) represents the logical end-to-end connection of streaming media data (audio or video) between two A/V devices. Stream data is interfaced with the upper layer. The A/V transport layer provides this stream connection to the application. More strictly, streaming data is source-encoded data, as the audio or video encoder and decoder conceptually reside in the upper layer.

In a multimedia application context, a stream typically corresponds to a single media channel. Exceptions apply where multiple media channels are encoded to an aggregate bit stream; e.g., in case of joint stereo encoding.

Although a streaming connection is unidirectional, bi-directional use of the transport channel is possible in case the transport layer exchanges feedback information. A stream handle (see Section 4.9) is used to uniquely distinguish one stream.

4.2 Source (SRC) and Sink (SNK)

As the stream represents unidirectional media data, the peer devices explicitly assume the roles of either a **SRC** or a **SNK**, depending on the application.

4.3 Initiator (INT) and Acceptor (ACP)

The device that initiates a procedure is considered as the INT of this procedure. The device addressed is the procedure's ACP.

The role of INT/ACP of a stream is independent of a device's role as SRC/SNK. The INT and ACP roles in the A/V transport protocol are not to be confused with the corresponding roles in the underlying L2CAP layer.

4.4 Application and Transport Service Capabilities

The A/V transport protocol represents a scalable architecture with different support levels of mechanisms used in the transport, or services provided to the upper layer. The support levels are described by a variable set of capabilities. The ACP typically exposes its capabilities to the INT that selects a configuration. The support of certain capabilities **may** also be mandated by a profile.

Application Service Capabilities correspond to services provided to the application layer. These comprise of, for example, the negotiation and configuration of source codecs, content protection systems and support of media synchronization.

Transport Service Capabilities correspond to more specifically transport-related "services" inside the transport layer. These comprise, for example, framing and segmentation, encapsulation, reporting of delivery performance, packet loss detection, packet recovery, robust header compression, and multiplexing transport sessions to transport channels.

4.5 Services, Service Categories, and Service Parameters

These terms are related to the transactions during the negotiation phase of the stream set-up procedure. To simplify the specification of transactions, the term **service may** refer to both Application Service Capabilities and Transport Service Capabilities, which are thus treated equally during the negotiation.

The description of services is organized in a hierarchy of Service Categories and Service Parameters. The **Service Category** represents the top-level structuring element. Examples of Service Categories are media transport, reporting, media recovery, media codec, content protection, robust header compression, and multiplexing mode.

Each Service Category **can** comprise of one or multiple **Service Parameters**, which **may** apply various options. For example, the Service Category audio streaming **may** imply Service Parameter as "SBC" and its options like "Sampling Frequency" and "Channel Mode".

An implementation **may** not support all Service Categories, or all Service Parameters within a Service Category, or all options of a Service Parameter. A stream handle (see Section 4.9) is used to refer to a stream context.

4.6 Media Packets, Recovery Packets, and Reporting Packets

The A/V transport layer interfaces streaming media with a packet-oriented bearer. Different AVDTP packet categories **can** occur. Streaming media is encapsulated in **Media** packets (RTP packet format defined by [3]). Media packets travel downstream; i.e., from the SRC to the SNK device.

Exception: when robust header compression is used then compression-related feedback packets **can** also travel upstream.

Depending on the supported services, the peer AVDTP entities **can** exchange further information. If packet recovery is used, **Recovery** packets containing recovery data are sent by the SRC. Recovery packet format is specified by [4]. If QoS reporting is used, information is encapsulated in **reporting** packets. RTCP packet format is specified by [3]. Reporting packets containing sender reports travel downstream, whereas those containing receiver reports travel upstream.

4.7 Stream End Point (SEP)

The Stream End-Point (SEP) is a concept to expose available Transport Services and AV capabilities of the Application in order to negotiate a stream. The Application registers its SEPs in AVDTP in order to allow other devices to discover and connect to them. A more detailed description **can** be found in § 5.3

4.8 Stream Context (SC)

In the course of a stream set-up procedure, both peer devices attain a common understanding of the configuration of the streaming, including the selected services, parameters, and the transport channel assignment.

Conceptually, a **stream context** exists in both end-points of a stream. Being associated to a single stream, the stream context, which could be seen as a kind of table, serves to collect and maintain all of this information. It is important that the stream contexts in both devices remain consistent and synchronized.

4.9 Stream Handle (SH)

A **Stream Handle** (SH) represents a top-level reference to a stream. The stream handle is exposed to the application layer, especially on the Upper Streaming Interface and the Reporting Interface. Moreover, the stream handle refers to the stream context associated with that stream.

The stream handle is a device-local identifier. It is independently assigned by the AVDTP entities of the INT and the ACP during the establishment of the stream connection. The scope of the stream handle is not local to a connection to a specific peer device (not connection-local). The stream handle is never exchanged on the air interface.

4.10 Stream End Point Identifier (SEID)

In contrast to the stream handle, the **Stream End-Point Identifier** (SEID) represents a cross-device reference to a specific stream. This reference is used in the signaling transactions; i.e., on the air interface, between the peer AVDTP entities.

A SEID is assigned at application level, of a device that responds to a stream discovery procedure. Here, the responding device exposes its basic stream end-points and basic capabilities, audio/video, SNK/SRC, and assigns the SEID as a unique reference for the further transactions. To prevent conflicts, the scope of the SEID **shall** be both device-local and connection-local. The application is responsible for assigning a SEID, which is not in use on the connection to the same peer device.

In the course of a stream set-up procedure, both AVDTP entities create the association between the local SEID and the local Stream Handle and typically store it in the Stream Context. Both SEID and Stream Handle appear on the Upper Signaling Interface.

Note: A unique mapping exists in each AVDTP entity between the Stream Handle and the pair of remote device address and SEID.

4.11 Stream End Point State

Various operations and transactions apply to a stream. A state machine is related to each stream and serves to control these operations. Aspects influencing the Stream State are, for example, if the negotiation procedure is in progress or complete, if transport channels are being established and assigned, if applications are expected to send or receive data on an available stream connection.

4.12 Transport Session

Internally to the A/V transport layer, a stream **can** be decomposed into one, two, or three transport sessions, which exist between the peer AVDTP entities. Each transport

session **can** be used for only one AVDTP packet category, which means Media, Recovery, or Reporting packets.

Thus, each stream connection comprises at least one-transport session containing Media packets. If packet recovery (RTP-FEC) is supported on a stream connection, another transport session contains the recovery packets. If QoS reporting (RTCP) is supported on a stream connection, another transport session contains the Reporting packets. A Transport Session Identifier (TSID, see Section 4.13) is used to refer to a transport session.

4.13 Transport Session Identifier (TSID)

The **Transport Session Identifier** (TSID) represents a reference to a Transport Session. Only in case of the Multiplexing Mode, the TSID is exchanged on the air interface (as part of the Media, Recovery, or Reporting packet header). In other terms, if the Multiplexing Mode is not configured on a stream connection, the TSID is not explicitly used.

The TSID is a cross-device reference, though its scope is connection-local. It is assigned by the AVDTP entity of the INT and **shall** be adopted by the AVDTP entity of the ACP.

The association of the contents type of a specific Transport Session (Media, Recovery, or Reporting packets) is signaled by the INT during the stream establishment procedure. After that, the association is maintained in the Stream Context of both devices.

4.14 Transport Channel

The notion of a **Transport Channel** means an abstraction of the bearer underlying the A/V transport layer. For the time being, a transport channel always corresponds to an L2CAP channel (with a PSM indicating AVDTP).

If the AVDTP Multiplexing Mode is not supported, a transport channel carries packets of only one transport session. If Multiplexing Mode is configured, a transport channel **can** carry packets belonging to different transport sessions (of the same or different streams). A Transport Channel Identifier (TCID, see Section 4.15) is used to refer to a Transport Channel.

4.15 Transport Channel Identifier (TCID)

The **Transport Channel Identifier** (TCID) represents a reference to a Transport Channel. Only in the case of the Multiplexing Mode, the TCID is exchanged on the air interface (during the stream establishment transactions). In other terms, if the Multiplexing Mode is not configured on a stream connection, the TCID is not explicitly used.

The TCID is uniquely related to one underlying L2CAP channel and its local channel identifier (LCID) of the connected L2CAP channel. In contrast to the LCID though, the TCID is a cross-device reference, though connection-local.

In the Multiplexing Mode, the TCID **shall** be used during the stream configuration transaction to signal the mapping of Transport Sessions to Transport Channels.

4.16 Reserved for Future Additions (RFA)

Bits with this designation **shall** be set to zero. Receivers **shall** ignore these bits.

4.17 Reserved for Future Definitions (RFD)

These bit value combinations or bit values are not allowed in the current specification but **may** be used in future versions. The receiver **shall** check that unsupported bit value combination is not used.

4.18 Forbidden (F)

This bit field combination is not allowed in the specification. The receiver **shall** check that this bit field combination is not used.

5 Architecture

Figure 5.1 shows the internal architecture of the AVDTP. The architecture includes block and interface functionality. This scope of this specification only deals with the shaded blocks highlighted in Figure 5.1.

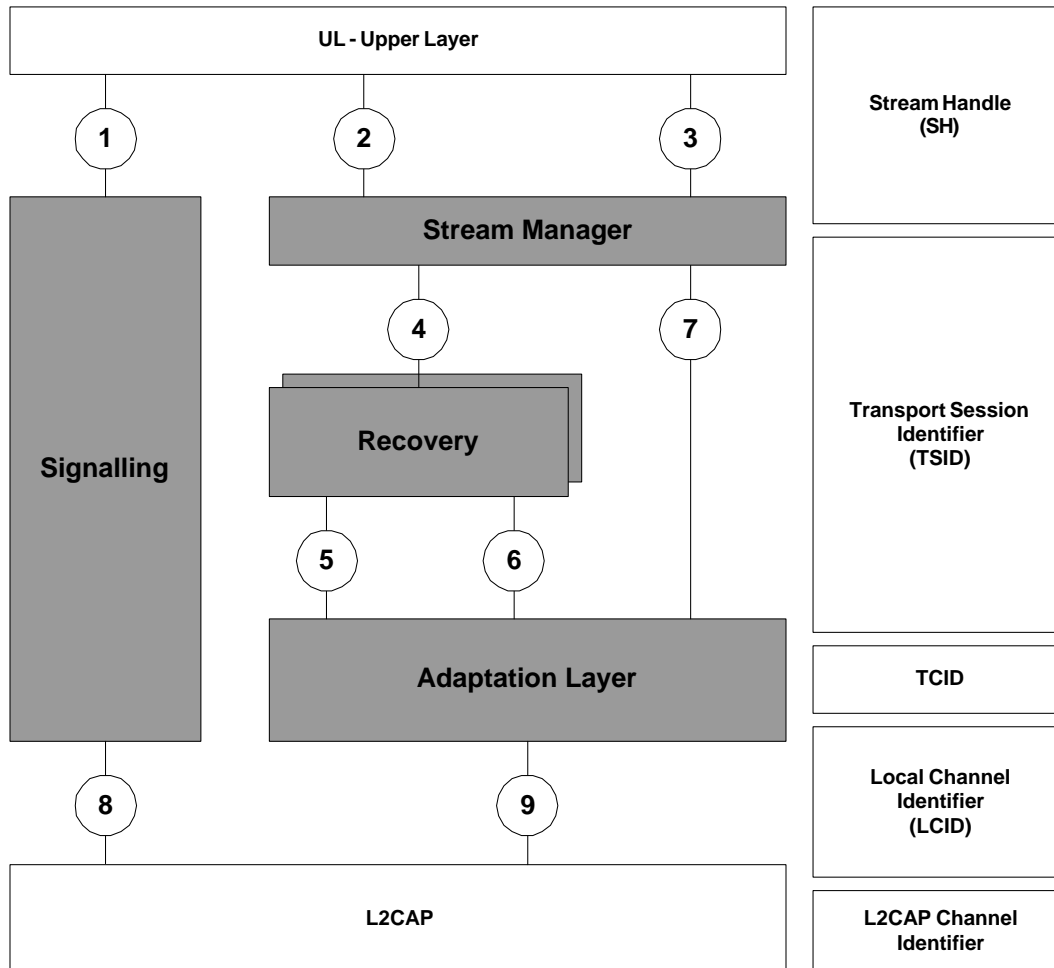

Figure 5.1: AVDTP Architecture

5.1 Block Functionality

5.1.1 Stream Manager

The stream manager provides the following functionality:

- Streaming
- Media framing
- Time stamp management
- Media packet sequence numbering
- Reporting of packet loss to peer and to higher layer

- Jitter calculation

5.1.2 Recovery

Recovery is based on [4] and offers the following options:

- No FEC
- Equal FEC

5.1.3 Adaptation Layer

Adaptation layer offers the following functionality:

- Header Compression using Robust Header Compression [5]
- Multiplexing mode to allow several transport sessions (TSID) to be multiplexed on one transport channel (TCID)

5.2 Interface Functionality

Interface	Description
1	Provides: <ul style="list-style-type: none">• Application Service Capabilities Discovery• Transport Service Capabilities Discovery• Stream Negotiation• Stream Establishment• Stream Destruction• Stream Suspend and Resume
2	Provides: <ul style="list-style-type: none">• Media Streaming• Timing information relative to streams
3	Provides: <ul style="list-style-type: none">• Quos reporting for media streams
4	Provides, if the stream is SRC: <ul style="list-style-type: none">• Media payload plus timing information• Primitives to report packet loss Provides, if the stream is SNK: <ul style="list-style-type: none">• Media payload plus sent and received timing information
5	Media transport framing
6	Recovery transport framing
7	Reporting
8	L2CAP channel for signaling entity
9	L2CAP channels for transport entity

Sections 5.4.1 to 5.4.5 show the configuration modes of the AVDTP. Configuration options are negotiated at set up time of an A/V service.

5.3 Stream End Point Architecture

An A/V device **may** provide one or several streaming resources, which means sources or sinks of media streams. Conceptually an end-point (source or sink) of a stream connection resides in the application layer of a device. However, end-points are represented in the AVDTP layer for negotiating and operating a stream. As shown in [Figure 5.2](#), AVDTP uses the concept of abstract **Stream End Points (SEPs)** that represent the resources and capabilities of a device.

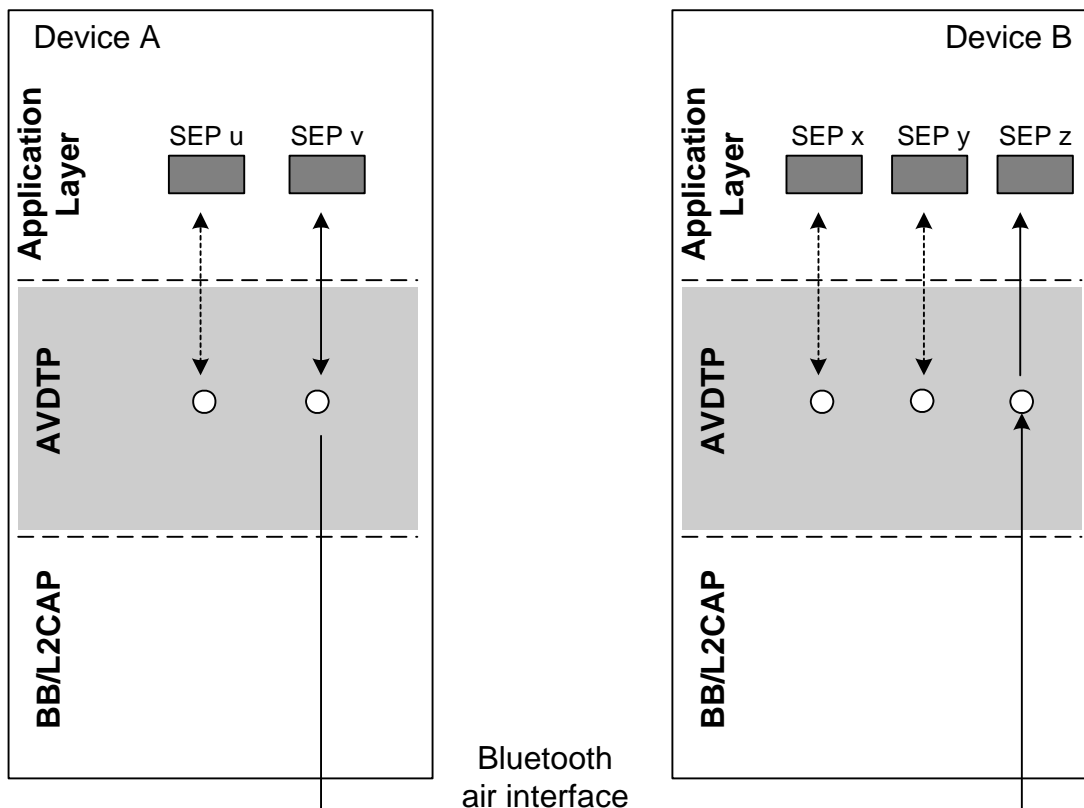

Figure 5.2: Stream End Point Architecture

Assume for example that device A has 2 SEPs labeled u and v, where SEP u represents a video sink, SEP v an audio sink. Device B has three SEPs labeled x, y, and z, which represent audio sources. Device A is supposed to set up an audio stream connection with one of the audio sources in Device B.

Both Device A and Device B maintain local **Stream End Point Identifiers (SEID)**, see section 4.10) for their SEPs, respectively. First Device A uses an AVDTP service to discover the resources of the peer device. From this procedure, Device A learns the (Device B local) SEIDs and type of media (here: audio sources) for the three SEPs in Device B. In the sequel, Device A uses another AVDTP service to collect the **Application and Transport Service Capabilities** for one of the remote SEPs, say for SEP z. During this transaction, Device B refers to SEP z by the SEID that Device B presented before. After knowing all the capabilities, which B has exposed, and comparing it to its own local capabilities, Device A **can** use yet another AVDTP service to configure the stream connection. Note that the assessment and decision how to

select the services occurs in the application layer of Device A, thus outside AVDTP. The existence of a local SEP *v* (with own local SEID), which has matching capabilities and thus **can** be connected with Device B's SEP *z*, is implicitly assumed. Consequently, the AVDTP entity of Device A does not need to know the capabilities of local SEP *v*. By starting the configuration procedure though, Device A implicitly acknowledges that it has matching capabilities in a local SEP and maps the local SEP *v* (with local SEID) to the remote SEP *z* (with remote SEID), such that both devices know the respectively remote SEID for future mutual reference. On successful termination of the configuration procedure, resources in both Device A and Device B **shall** be allocated (locked), and neither SEP *v* in Device A nor SEP *z* in Device B could be configured for another stream connection e.g. by a third device.

Note that although both devices conceptually have SEPs, their relation follows an asymmetrical client-server model, where the application uses AVDTP services to manage streaming resources in the remote device. Device B exposes all of its capabilities to Device A, but Device A does not expose its capabilities to Device B. In subsequent signaling procedures, the stream connection **shall** be referenced by the SEID of the remote Device. In Device A, a local SEP (resource) necessarily exists and has capabilities that are sufficient to establish an interoperable streaming connection.

A state machine belongs to each Stream Endpoint and is present within the AVDTP layer. All state changes that are significant to the application **shall** be exposed through the upper interface.

Each codec supported by the application **shall** use a separate Stream End Point, but there **can** be multiple Stream End Points for the same codec.

5.4 Transport Services

5.4.1 Basic Service

When AVDTP is configured for Basic Service, Signaling and Stream Manager are the only active entities, as shown in [Figure 5.3](#).

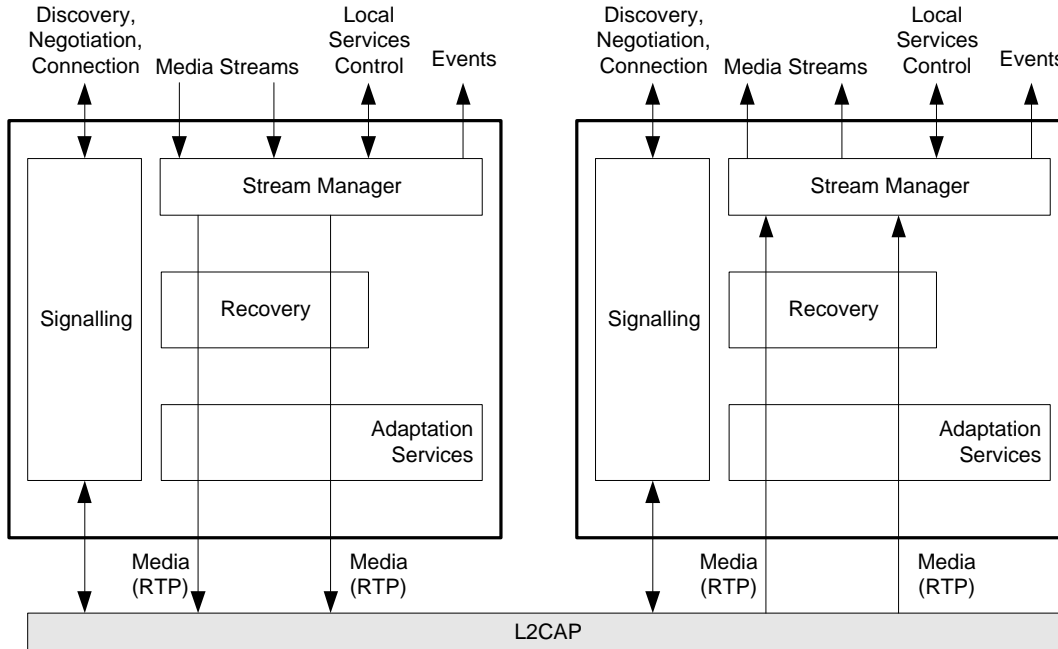

Figure 5.3: AVDTP Basic Service

The AVDTP basic service ensures the transport of Media packets of each session over individual transport channels. The service offers an appropriate interface that enables applications to stream in/out packet units that fit the maximum size requirements of the transport channel. This packet size limitation is returned to the application when the channel has been successfully configured.

5.4.2 Recovery Service

When AVDTP is configured to use Recovery Service, the recovery entity becomes active in addition to Basic Service and other configured services, shown in [Figure 5.4](#).

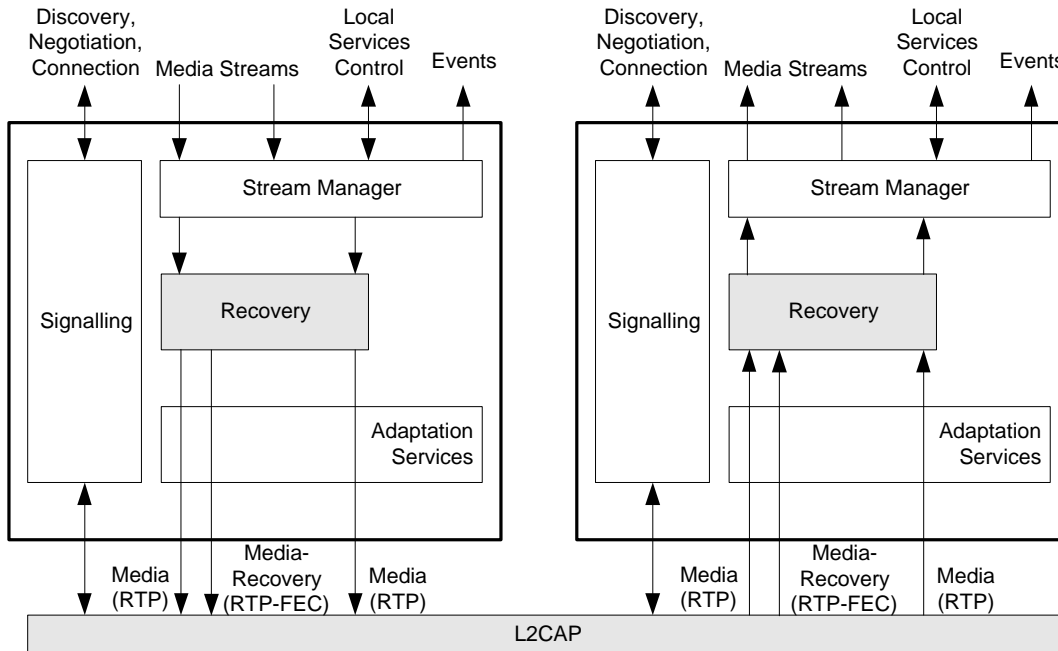

Figure 5.4: AVDTP Recovery Service

The recovery service uses media packets of one transport session at the SRC side to generate additional coded packets; these recovery packets **can** be used at the SNK side to reconstruct original Media packets that have been lost on the air transmission path.

This service is specifically useful in applications that have huge bandwidth requirements and limited retransmission capabilities. In contrast to the Baseband FEC, the recovery service implements a flexible on-demand error correction mechanism: applications get full control of service operation with respect to the channel condition and **can** decide to only cover the most sensible parts of the media stream. The service performs independently of the Baseband packet type and is selectable for each active transport session.

To combat interference efficiently all Recovery packets are conveyed through a separate transport channel.

5.4.3 Reporting Service

When AVDTP is configured to use Reporting Service, the reporting interface becomes active in addition to Basic Service and other configured services, shown in [Figure 5.5](#).

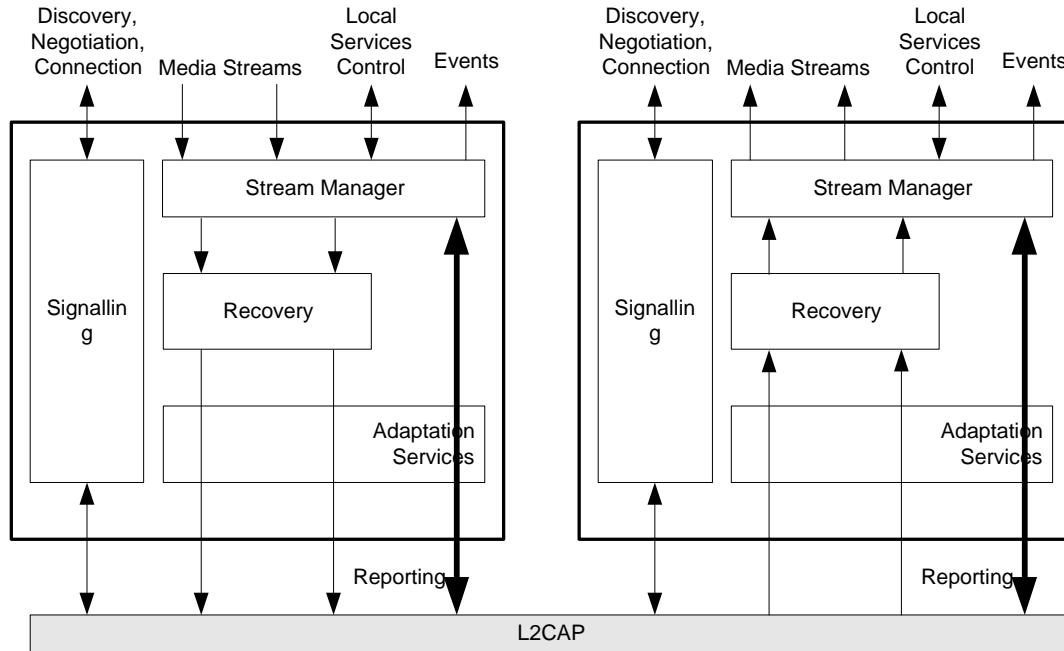

Figure 5.5: AVDTP Reporting Service

When switched on, the reporting service provides statistical information to the local application and to the remote device about time alignment of the media streams and packet losses. These reports are used to achieve appropriate media streams synchronization and/or to adapt the error concealment strategy of the applications.

The reporting service **can** be configured one-way (from SNK to SRC or SRC to SNK) or both-ways, depending on application requirements. The service interface allows the application to adjust the periodicity of the reports and to activate/deactivate the service according to the context.

The reporting service **can** use an independent transport channel to transmit Report packets to the remote side.

5.4.4 Adaptation Service – Multiplexing

In the Multiplexing Mode, multiple transport sessions, belonging to the same or to a different stream, **can** share a common transport (L2CAP) channel. Moreover, an L2CAP packet **can** contain multiple packets belonging to the same or different transport sessions. An encapsulation header is therefore needed for each Media/Reporting/Recovery packet. A TSID contained in this header allows for correct routing of the packet at the SNK device.

During the **Stream Configuration** procedure, the INT has assigned TSIDs and TCIDs and communicated them to the ACP. To avoid conflicts in a multi-device configuration and to reduce its width, the scope of the TSID and TCID is restricted to the connection between a pair of devices. The **Stream Establishment** procedure does not necessarily open a new transport (L2CAP) channel. Instead, it **can** map a new transport session to an existing L2CAP channel. This is achieved by referencing an existing TCID.

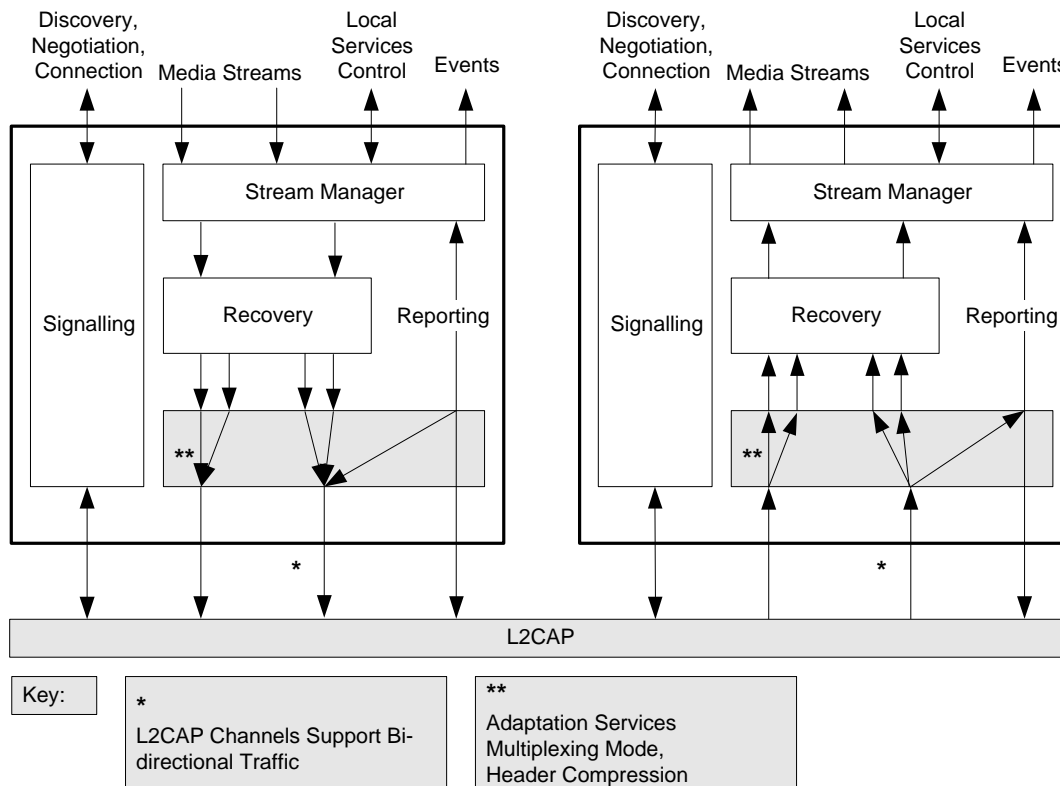

Figure 5.6: AVDTP Adaptation Service Option

The Multiplexing Mode functionality resides in the Adaptation Services layer of AVDTP. It takes effect only at the time the stream is established, and does not affect the Stream End-point concept and the organization of stream and session as exposed to the upper layer.

In the case the Media packet size exceeds the MTU requirement of the transport channel the Multiplexing mode **can** be configured with an optional fragmentation service to transmit the Media packet into smaller chunks to fit the transport channel requirements. If the fragmentation service of the Multiplexing mode is supported on the stream connection, the INT **may** select this feature as an alternative to the Media packet fragmentation at application level. The Media packet fragmentation performs automatically during the streaming provided it has been configured before the stream is open.

5.4.5 Adaptation Service – Robust Header Compression

Robust Header Compression is a Transport Service that reduces the overhead that the headers of the Media packets and Recovery packets introduce. This mechanism is fully selectable by the application, but the same configuration **shall** be set-up at both sides of the connection for each stream to be established. The **Robust Header Compression** mechanism allows the use of a feedback channel, which is negotiated at the time the media stream is configured.

5.4.6 Transport and Signaling Channel Establishment

Up to four L2CAP channels **can** be required between two devices participating in a streaming connection. Because L2CAP signaling does not provide the correct information to distinguish which L2CAP channel is intended for a specific transport channel, rules are set out as to the L2CAP channel establishment order.

Figure 5.7, shows the priority order of establishment for L2CAP channels. The numbers represent the priority order of the channel establishment.

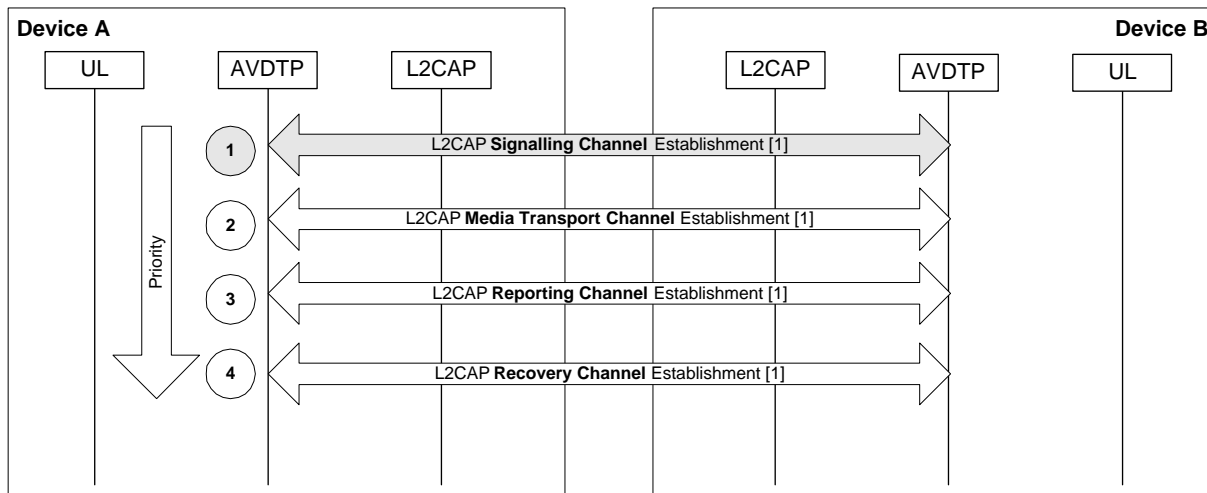

Figure 5.7: Transport and Signaling Channel Establishment

The signaling channel (1) is only established once between two streaming devices. Media, Reporting and Recovery Transport channels are established on a per stream basis. The priority order of the channel establishment is depicted in Figure 5.7. The numbers dictate the order of priority. If a stream only requires Media and Reporting services, and the Signaling channel is already established, the Media Transport (Basic Service) **shall** be the first Transport Channel to be established and the next one **shall** be the Reporting Transport Channel. Similarly, if a stream only requires Media Transport (Basic Service) and Recovery Service then the order of channel establishment **shall** start with the Media Transport Channel then the Recovery Transport Channel **shall** be established. If however, the Signaling Channel is not established, and a stream requires all Transport Services, the first channel to be established **shall** be the Signaling Channel followed by the Media Transport Channel the Reporting Transport Channel and then the Recovery Transport Channel.

6 Signaling Procedures

6.1 General Requirements

Signaling procedures require an ACL link between a pair of interconnected devices. Transactions are performed on a connection-oriented channel established between communicating devices, and consist of bi-directional asynchronous message exchanges.

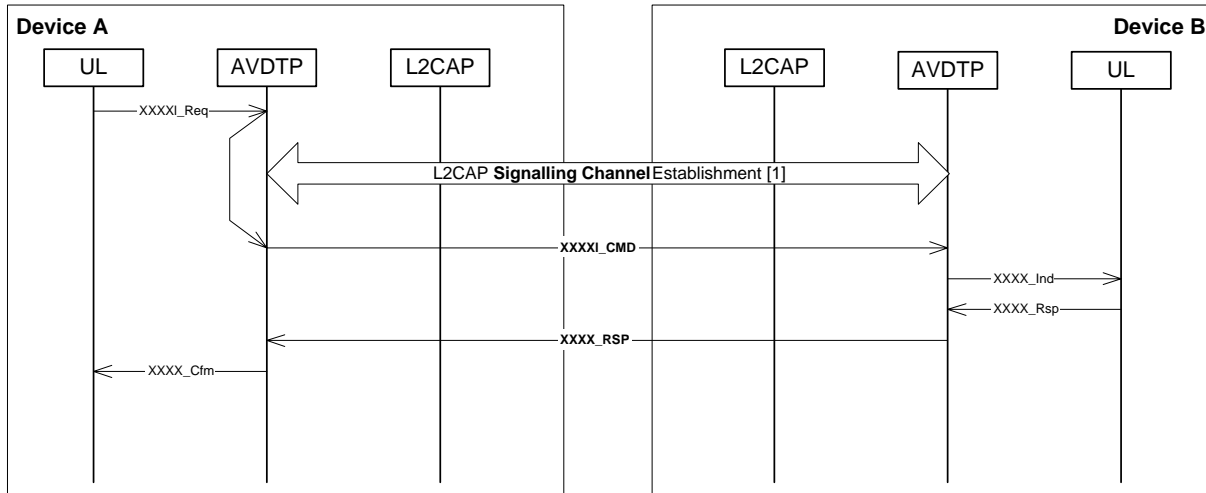

Figure 6.1: Signaling Channel Establishment Procedure

An L2CAP channel is used for signaling and is established and released by L2CAP signaling commands. A specific Protocol/Service Multiplexer (PSM) value is allocated for AVDTP transactions handled by L2CAP.

6.2 Transaction Model

AVDTP follows the transaction model defined in L2CAP (see Section 3 of L2CAP in the Bluetooth Core Specification).

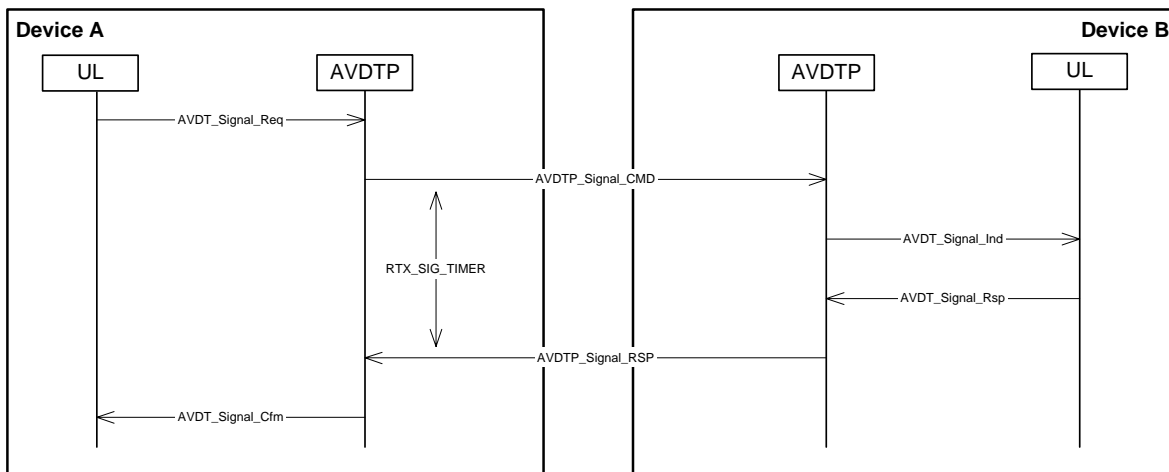

Figure 6.2: Transaction Model of AVDTP Command/Response

Figure 6.2 shows a message sequence chart (MSC) to illustrate the normal sequence for signaling events. The two outer vertical lines represent AVDTP signaling entities within the INT and the ACP. When AVDT_Signal_Req is sent from the upper layer (UL), the AVDTP of the INT sends AVDTP_SIGNAL_CMD to the AVDTP of the ACP. After receiving AVDTP_SIGNAL_CMD, the AVDTP of the ACP passes AVDT_Signal_Ind to its upper layer (UL). When the upper layer has dealt with AVDT_Signal_Ind, an AVDT_Signal_Rsp is sent back to AVDTP layer. This produces an AVDTP_SIGNAL_RSP back to the AVDTP of the INT. After receiving AVDTP_SIGNAL_RSP, the AVDTP of the INT signals back to the upper layer in the form of an AVDT_Signal_Cfm.

- AVDT_Signal_Req: from upper layer to a remote device
- AVDT_Signal_Cfm: confirm the request from a remote device to upper layer
- AVDT_Signal_Ind: indicate the request has been received from a remote device to upper layer
- AVDT_Signal_Rsp: respond from upper layer to a remote device.

A Response Timeout eXpired (RTX_SIG_TIMER, specified by Profiles) timer is used to terminate the signaling when the remote side is unresponsive to the signaling request.

6.3 Stream Management Signaling Overview

Figure 6.3 shows an overall procedure to manage a stream connection. Either or both devices **may** initiate a stream, consisting of the **Stream Configuration** procedure, **Stream Establishment** procedure, and the **Stream Start** procedure.

The **Stream End Point Discovery** procedure, marked as optional here, serves to return the type and identifier (SEID) for one stream end-point, or jointly for multiple stream end-points. Since the SEID is needed as a reference in the following procedures, the Discovery procedure **shall** have been triggered before hand. However, the **Discovery** procedure is not needed for each individual stream end-point, or for example, repeated configuration attempts.

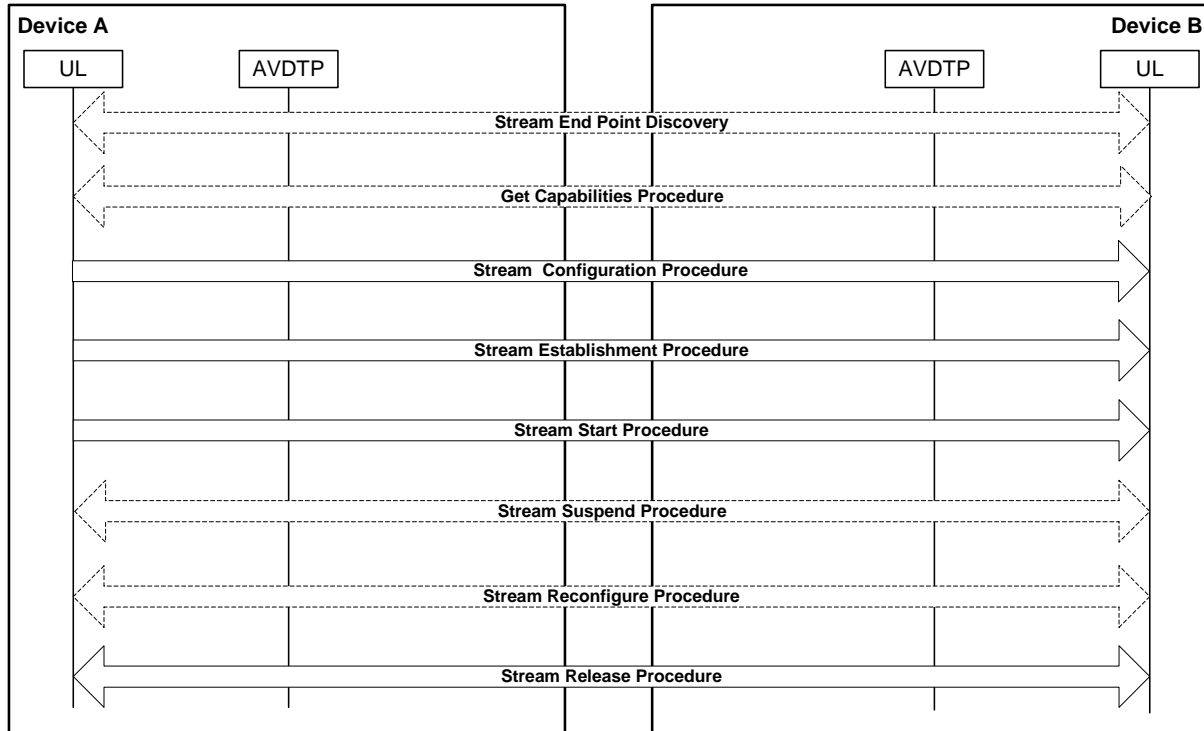

Figure 6.3: Stream End-point Discovery to Stream Release

The **Get Capabilities** procedure is also optional, as an INT **may** “guess” the capabilities of an ACP and directly try the **Stream Configuration** procedure. The **Get Capabilities** procedure **can** be triggered by any of the devices and is without effect on the stream end-point states. Nevertheless, since prior to the **Stream Configuration** there does not exist any resource reservation, and thus relation between peer stream end-points, the device triggering the **Get Capabilities** procedure **shall** have triggered a Discovery procedure to retrieve a SEID for reference earlier. Moreover, because of the **Stream Configuration** procedure, both devices know the mapping of the local and remote SEP by the corresponding pair of local and remote SEIDs and there exists a dedicated relationship between peer stream end-points in both devices.

Only the INT of a **Stream Configuration** procedure **may** be the INT of the **Establishment and Start** procedures that normally follow to perform streaming over the configured SEP. After the **Start** procedure has completed however, both devices **may** trigger any of the **Stream Suspend**, **Stream Reconfigure**, or **Stream Release** procedures. In those transactions, the initiating device refers to the SEID of the remote SEP, which means that the SEID used in the signaling messages depends on which device is the INT of the procedure.

A regular termination of a stream always involves a **Stream Release** procedure. The use of the **Stream Suspend** and the **Stream Reconfigure** procedure depends on the application. However, a **Stream Suspend** procedure **shall** precede a **Stream Reconfigure** procedure.

A **Security Control** procedure is also defined for content protection. How to use this procedure is defined by each control protection method.

6.4 Signal Command Set

The following table shows the signaling command set defined for AVDTP. Details for information elements **can** be found in section 8.

Command	Description
AVDTP_DISCOVER	Discover Stream End-points supported within a device.
AVDTP_GET_CAPABILITIES	Get the capabilities of a Stream End-point (SEP).
AVDTP_SET_CONFIGURATION	Set the Configuration of a SEP.
AVDTP_GET_CONFIGURATION	Get the current Configuration of a SEP.
AVDTP_RECONFIGURE	Request that a SEP be Reconfigured.
AVDTP_OPEN	After successful configuration of a SEP, this signal is used to open the stream.
AVDTP_START	This signal has two purposes, these are: <ul style="list-style-type: none"> Once a stream has been opened, this signal is used to start the streaming. When a stream has been suspended, this signal is used to restart the streaming.
AVDTP_CLOSE	Request the closure of a SEP.
AVDTP_SUSPEND	Request that a SEP be suspended.
AVDTP_SECURITY_CONTROL	Exchange content protection control data.
AVDTP_ABORT	The abort signal is used to recover from error conditions.

6.5 State Machine Overview

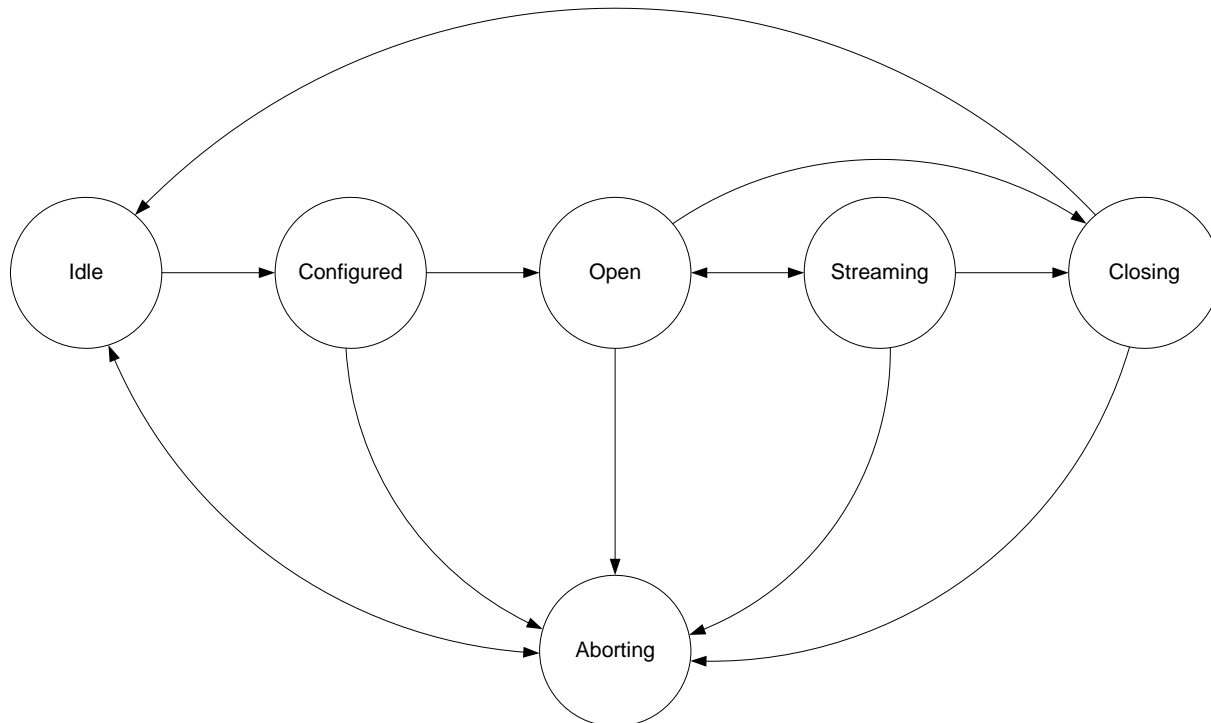

Figure 6.4 : AVDTP State Machine Overview

This section provides an overview of the Stream End Point State Machine. For a definition and detailed description of the different states see section 9.

When the ACP rejects an INT command, it **shall** complete the procedure by falling back to the initial state of this (local) procedure. On receipt of a reject from the ACP side the INT shall complete the procedure by falling back to the initial state of this (local) procedure.

6.6 Stream End Point Discovery

An A/V stream on a Bluetooth link is sent or received by Bluetooth devices via an abstract **Stream End Point (SEP)**, which is referenced by a **Stream End Point Identifier (SEID)**. A device **can** discover the SEPs of the remote device; i.e., potential SRC(s) and/or SNK(s) of streaming connections, by the **Stream End Point Discovery procedure**. The result of this procedure provides a list of SEPs along with the media types that the remote device supports.

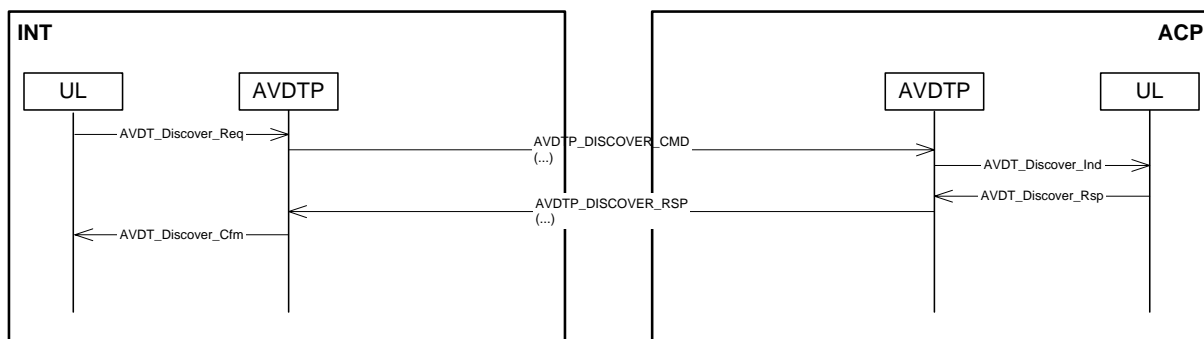

Figure 6.5: Stream End Point Discovery Procedure

6.7 Get capabilities

Using the SEID as a reference, the local device **can** query the service capabilities of the remote SEP using the **Get Capabilities Procedure**. If a SEP is already in use by another stream connection, the **Discovery** and **Get Capabilities** procedures **may** or **may** not yield valid entries for this SEP.

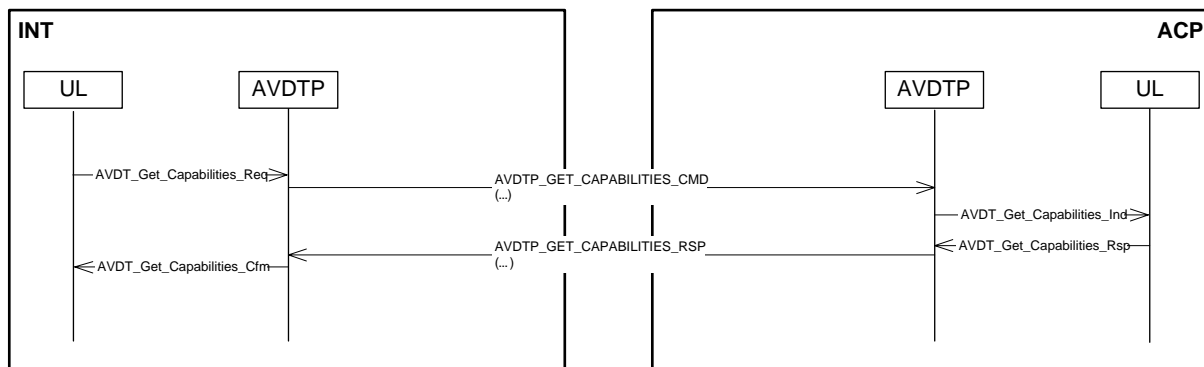

Figure 6.6: Get Capabilities Procedure

6.8 Stream Configuration

By referencing both the local and the remote SEID, the local device (the INT) configures the SEP of the remote device (the ACP) using the **Set Configuration** procedure. If a

SEP is in use by another stream connection, the configuration procedure **shall** fail and yield an error indication. After a successful configuration, the stream connection **can** be established.

The INT configures a remote SEP by conceptually creating one, two, or three **transport sessions** associated with this SEP. The first transport session is always used for transporting Media packets of the stream. If the reporting (recovery) option is configured for this stream, another transport session is opened for Reporting (Recovery) packets. A transport session **shall** be referenced by a **Transport Session Identifier (TSID)** if the Stream End Point is also configured to operate in multiplexing mode.

Especially for the AVDTP service interface, it is impractical to refer to a stream connection by the pair of a remote device address and the (connection-local) SEID. A device-local Stream Handle is assigned by AVDTP instead and, in each device, this local Stream Handle is returned to the application during the **Stream Configuration** procedure.

When the multiplexing mode is configured, explicit **Transport Channels Identifiers (TCIDs)** are associated to the **Transport Sessions Identifiers (TSIDs)** for an appropriate channel mapping during the **Stream Establishment** procedure.

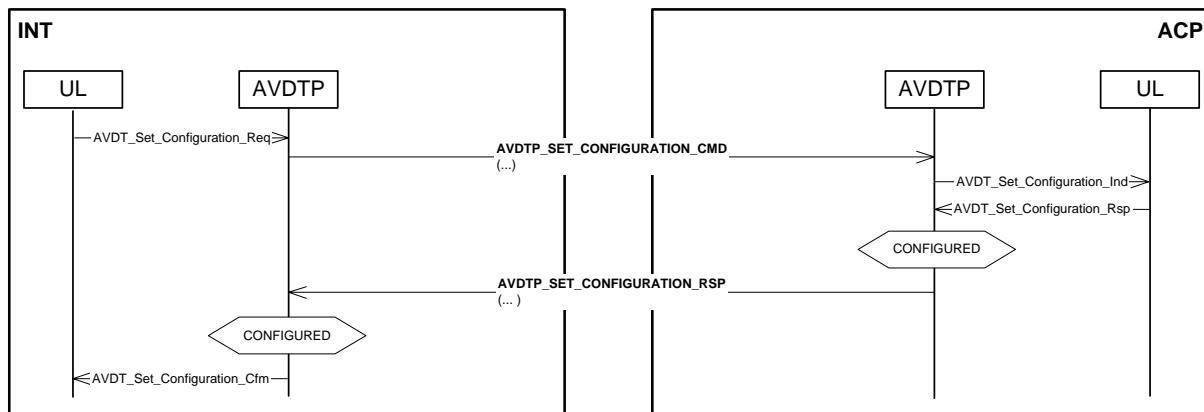

Figure 6.7: Stream Configuration Procedure

6.9 Stream Get Configuration

A device **can** initiate a **Stream Get Configuration** procedure to retrieve the last capabilities settings performed by the remote device on the SEP identified by the addressed SEID. The addressed Stream End Point **shall** have been previously configured for streaming between the peer devices. Hence, the procedure **shall** fail when the addressed SEP is in **Idle**, **Closing** or **Aborting** state.

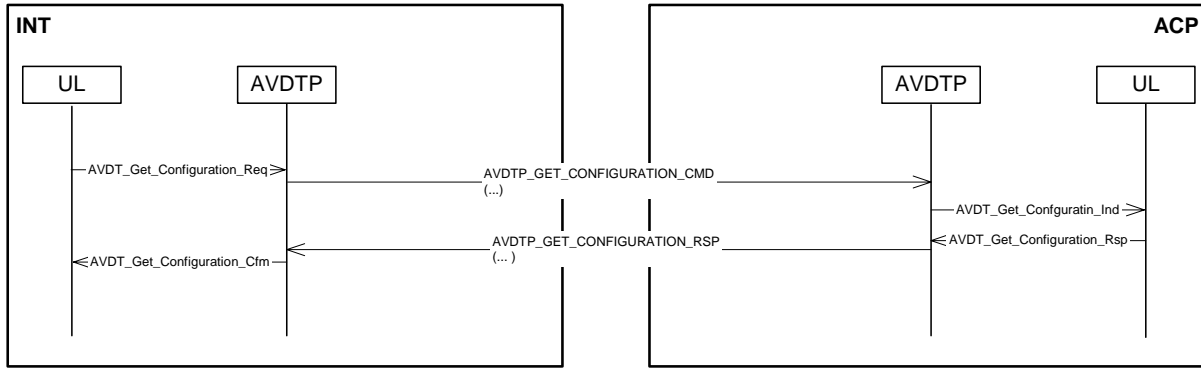

Figure 6.8: Stream Get Configuration Procedure

6.10 Stream Establishment

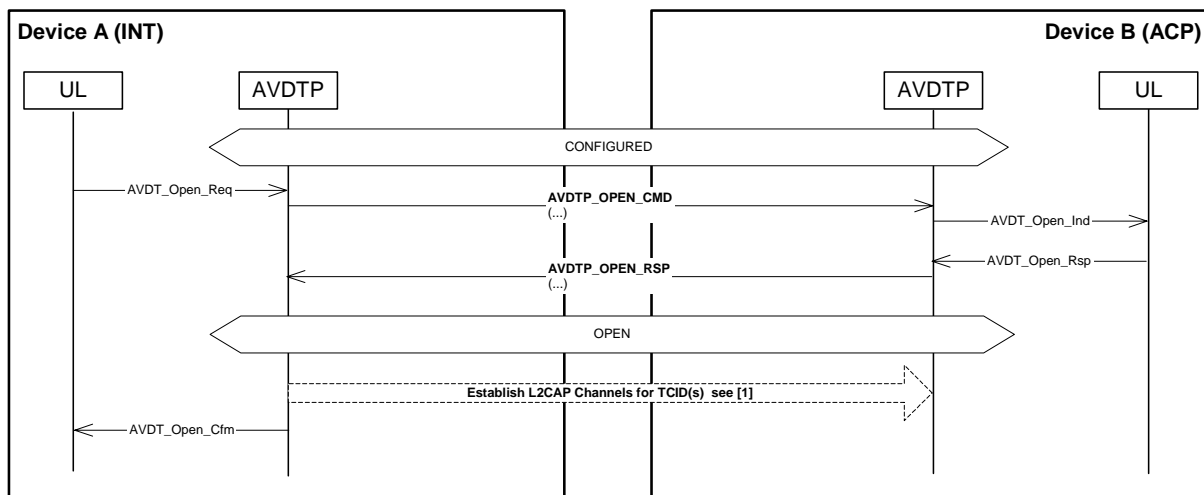

Figure 6.9: Stream Establishment Procedure

The opening of a transport session, while referencing the remote SEID, includes, if necessary, the establishment of a new **Transport Channel**.

When the multiplexing mode is not configured, a new L2CAP channel is always established and uniquely mapped to that transport session. In this mode neither **Transport Session Identifiers (TSIDs)** nor **Transport Channel Identifiers (TCIDs)** are explicitly needed to establish the connection: each device **can** unambiguously and implicitly associate each transport session to its own transport (L2CAP) channel according to the rules of section 5.4.6.

When the multiplexing mode is configured, explicit **Transport Channels Identifiers (TCIDs)** have already been associated to the **Transport Sessions Identifiers (TSIDs)** during the **Stream Configuration** procedure. In case a transport channel does not yet exist, new L2CAP channel(s) is (are) established and associated with the relevant TCIDs.

For the establishment of multiple transport sessions, the Stream Establishment Procedure for one session, including all related L2CAP channel establishments, **shall**

be completed before the Stream Establishment Procedure for the next session is initiated.

6.11 Stream Start

After the Stream Establishment is complete, the **Start Streaming** procedure causes the streaming to start; i.e., Media (Reporting, Recovery) packets **can** be exchanged. The **Start Streaming** procedure **can** be initiated by either device participating in a streaming connection.

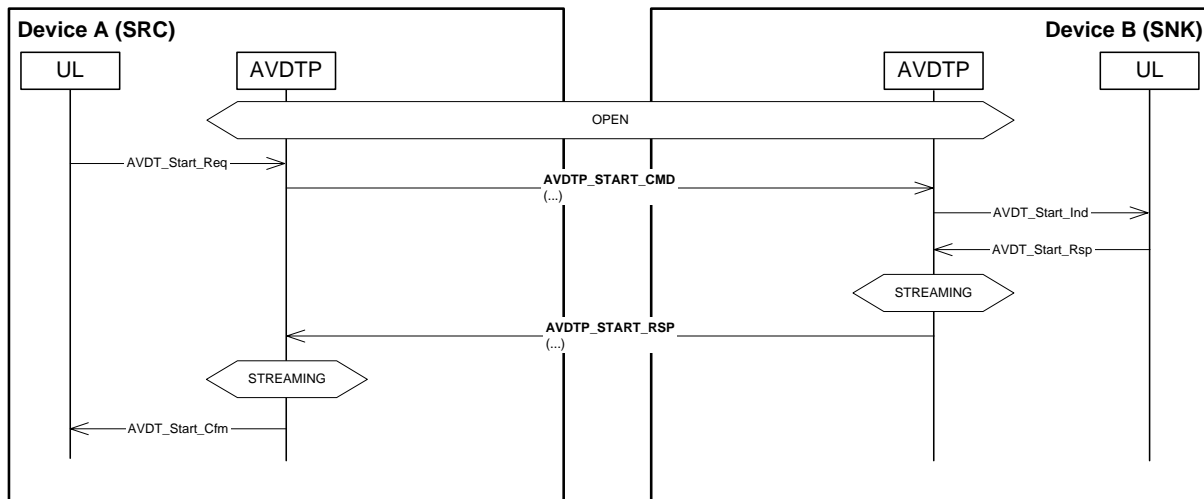

Figure 6.10: Stream Start Procedure, Device A is a Source Device

Figure 6.10 and Figure 6.11 show the **Start Streaming** procedure. The state of the SEP is dependent upon whether the device is SNK or SRC.

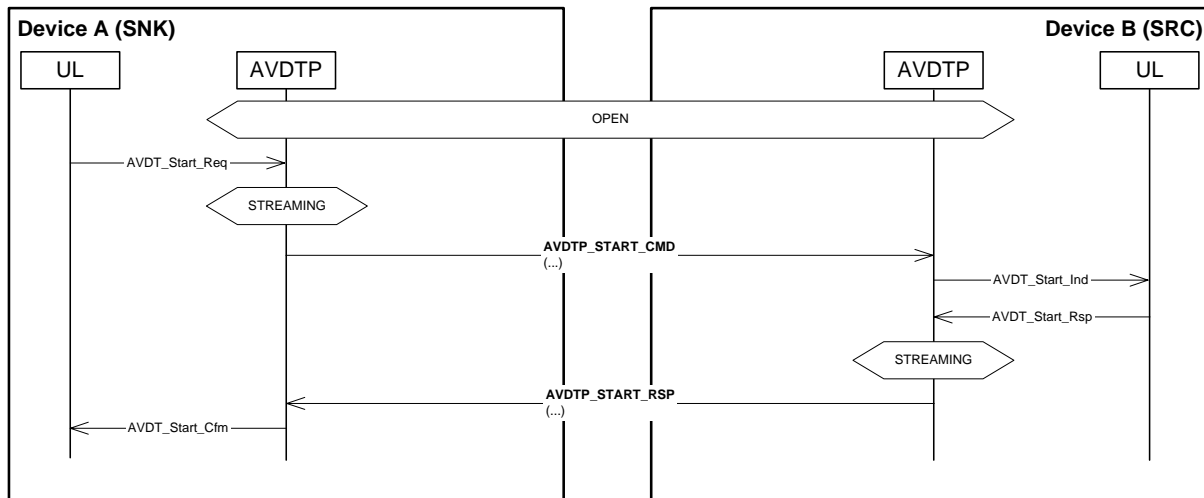

Figure 6.11: Stream Start Procedure, Device A is a Sink Device

6.12 Stream Release

Stream release is initiated by the upper layer within a device; a signal is sent indicating that a stream end-point be closed. The stream end-point is identified by its remote SEID.

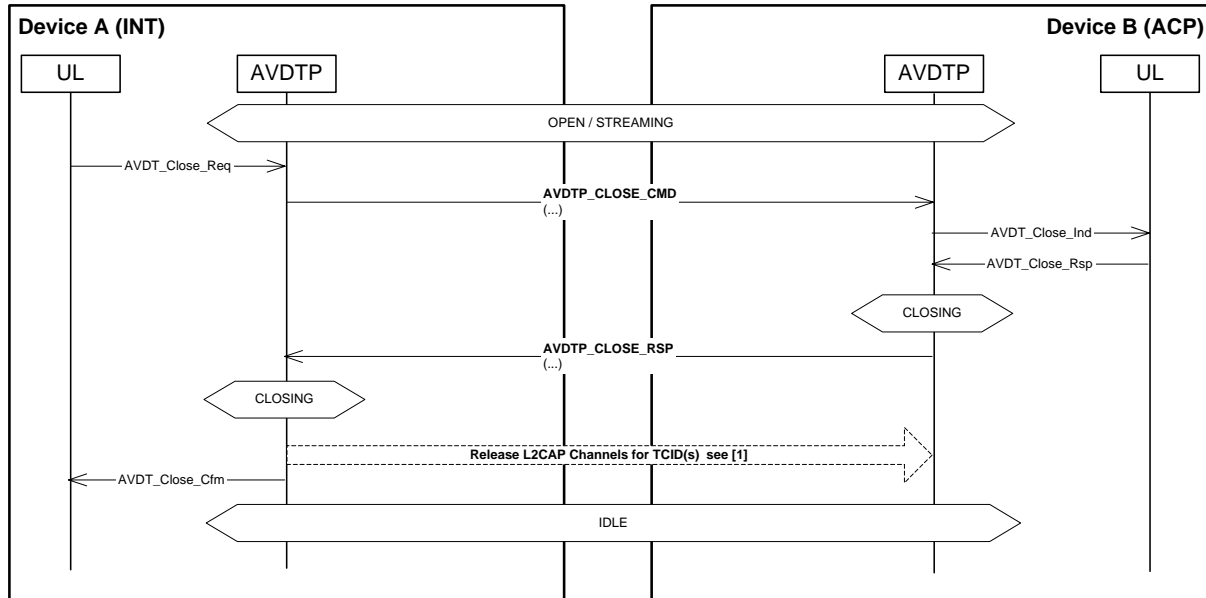

Figure 6.12: Stream Release Procedure

The device that initiates the stream release becomes the INT of the procedure. When the ACP receives the indication that a stream end-point is to be released, the ACP releases all the resources allocated to the stream end-point. This includes buffer resources, etc. After the INT receives a confirmation that the stream end-point has been released, the INT releases all the transport channels and resources allocated to the stream end-point.

6.13 Stream Suspend

Figure 6.13 shows the stream suspend procedure. The device that initiates the procedure becomes the INT.

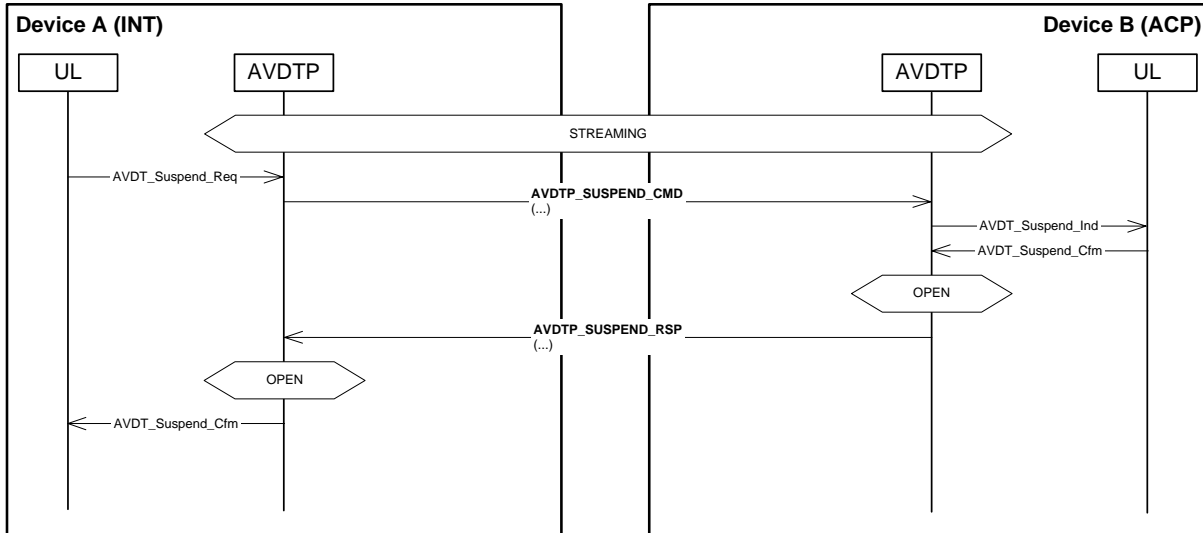

Figure 6.13: Stream Suspend Procedure

Assume the upper layer within the INT requests that a stream (given e.g. by a stream handle) is to be suspended; A command is sent to the ACP referencing the remote SEID for that stream. After the ACP has suspended its SEP, a response is sent back to the INT, which in turn suspends its SEP.

6.14 Stream Reconfigure

Figure 6.14 shows the procedure to reconfigure a stream. The first step is to perform a **Suspend Streaming Procedure**. When the stream is successfully suspended, a reconfigure command is used to change current capability settings. When the stream is successfully reconfigured, the stream is restarted using the **Start Streaming Procedure**.

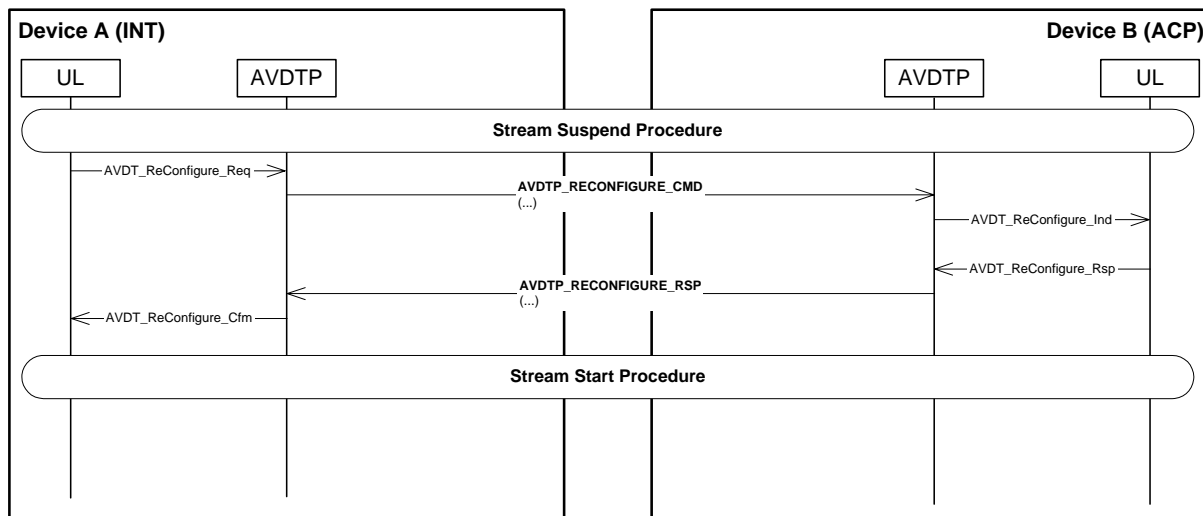

Figure 6.14: Stream Reconfigure Procedure

6.15 Security Control

If AV data transmitted over a Bluetooth link requires protection, a content protection method **can** be invoked. Several content protection methods are available and AVDTP signaling has a capability of negotiating content protection type. The procedure of exchanging content protection control data is composed of the following.

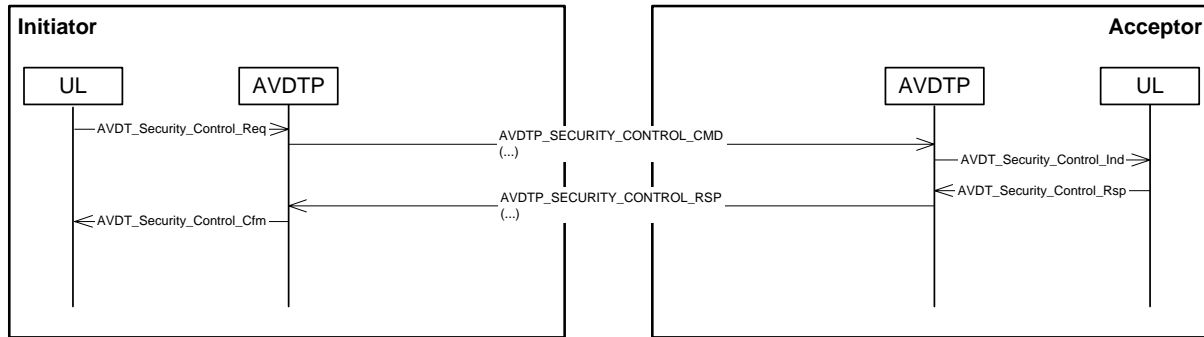

Figure 6.15: Content Security Control Procedure

6.16 Abort

Because AVDTP is typically used on unreliable channels, signaling messages **can** be lost due to L2CAP Flush Timeouts. To react to inconsistencies between the INT and ACP states, the Abort Command **may** be used. From Figure 6.16, INT and ACP SEP state progresses to <IDLE> independent of the current SEP state. All associated Transport Channels **shall** be closed. Only in case Transport Channels **shall** be closed, <ABORTING> state **shall** be used as depicted in Figure 6.16.

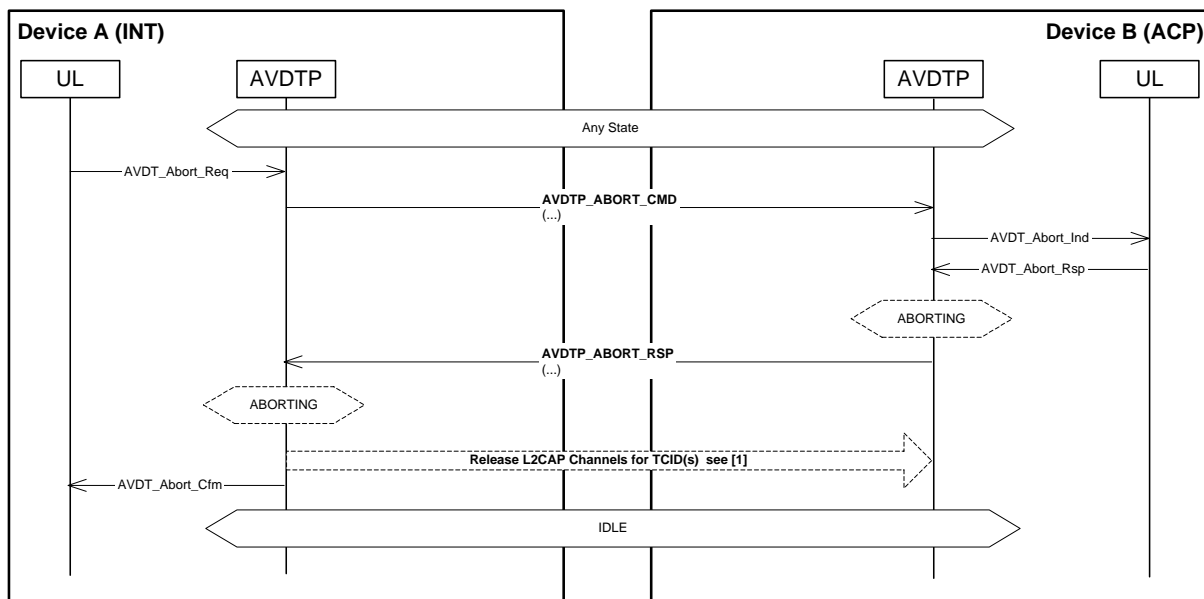

Figure 6.16: Abort Procedure

6.17 General Reject

The General Reject message **shall** be used by an ACP to respond to a command message that contains an invalid Signal Identifier.

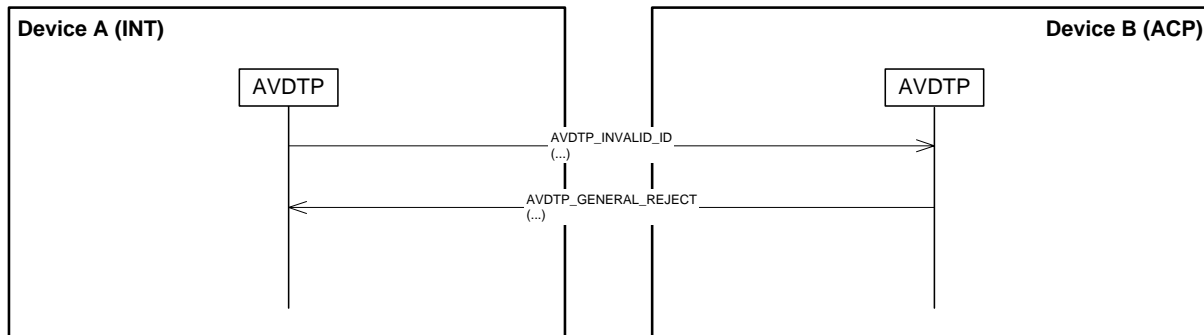

Figure 6.17: General Reject Procedure

7 Transport Procedures

7.1 General Requirements

Transport procedures require an ACL link that has been formerly established between a pair of interconnected devices. Transactions are performed on a connection-oriented channel available on the link between communicating devices.

L2CAP channels are used for media streaming. Establishment of the L2CAP channels, used for media streaming, is initiated by the Upper Layers and are set up and released as specified in [1] by AVDTP. A specific Protocol/Service Multiplexer (PSM) value is allocated for the service of AVDTP transactions on such channels [6].

7.2 Basic Service

The basic service offered to the upper layer by AVDTP provides only signaling and media streaming. Figure 7.1 shows the configuration of AVDTP and L2CAP. Two lower interfaces are exposed to L2CAP; these two interfaces carry signaling packets and media transport packets.

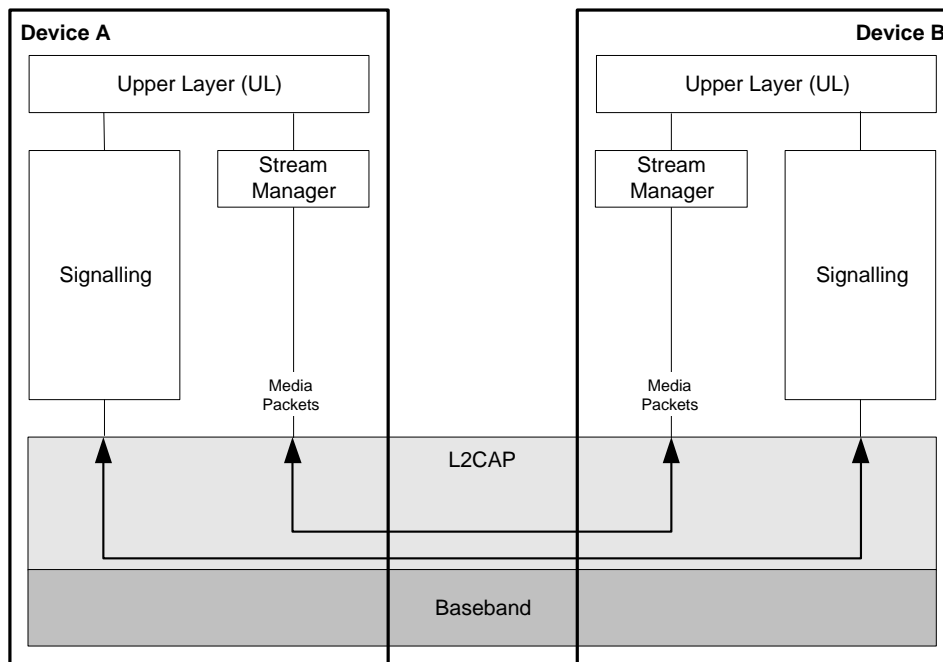

Figure 7.1: Transport Channels for Media Transport

To establish a stream, the upper layer requests the signaling entity to discover, configure, and establish streams. When a stream is established, the upper layer **can** send or receive streaming media, depending on whether the stream is SRC or SNK.

7.2.1 Media Packet Format

This chapter defines the structure of the media transport packets and defines the function and information contents of each packet.

Figure 7.2, shows media packet header format, which is described in [3]. The media packet header has 12 bytes mandatory field (with SSRC field) and optional field (CSRC). SSRC field is only used for multicast application, because SSRC field identifies the source-node ID on the specific Media transport session.

The order of transmission of the header and data described in this document is resolved to the octet level. Whenever a diagram shows a group of octets, the order of transmission of those octets is the normal order in which they are read in English. For example, in Figure 7.2 the octets are transmitted in the order they are numbered.

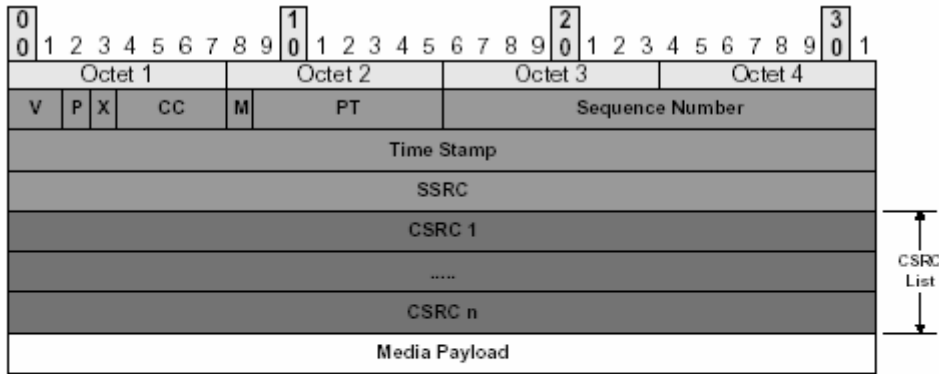

Figure 7.2: Media Packet Format

The information elements are described in Table 7.1.

Information Element	Description	Length
Version (V)	Version of the RTP implementation	2 Bits
Padding (P)	If the padding bit is set, the packet contains one or more additional padding octets at the end, which are not parts of the payload. The last octet of the padding contains a count of how many padding octets should be ignored.	1 Bit
Extension (X)	If the extension bit is set, the fixed header is followed by exactly one header extension.	1 Bit
CSRC count (CC)	The CSRC count contains the number of CSRC identifiers that follow the fixed header.	4 Bits
Marker (M)	The interpretation of the marker is defined by a profile. It is intended to allow significant events such as frame boundaries to be marked in the packet stream.	1 Bit
Payload Type (PT)	This field identifies the format of the RTP payload and determines its interpretation by the application. A profile specifies default static mapping of payload type codes to payload formats.	7 Bits
Sequence Number	The sequence number increments by one for each media packet sent, and may be used by the receiver to detect packet loss and to restore packet sequence.	16 Bits
Time Stamp	The Time Stamp reflects the sampling instant of the first octet in the media packet.	32 Bits
SSRC	The SSRC field identifies the synchronization source. This identifier is chosen randomly, with the intent that no two-synchronization sources, within the same media transport session, shall have the same SSRC identifier.	32 Bits
CSRC list	The CSRC list identifies the contributing sources for the payload contained in this packet.	0 to 15 items, 32 Bits each

Table 7.1: Media Packet Information Elements (taken from [3])

7.3 Reporting Service

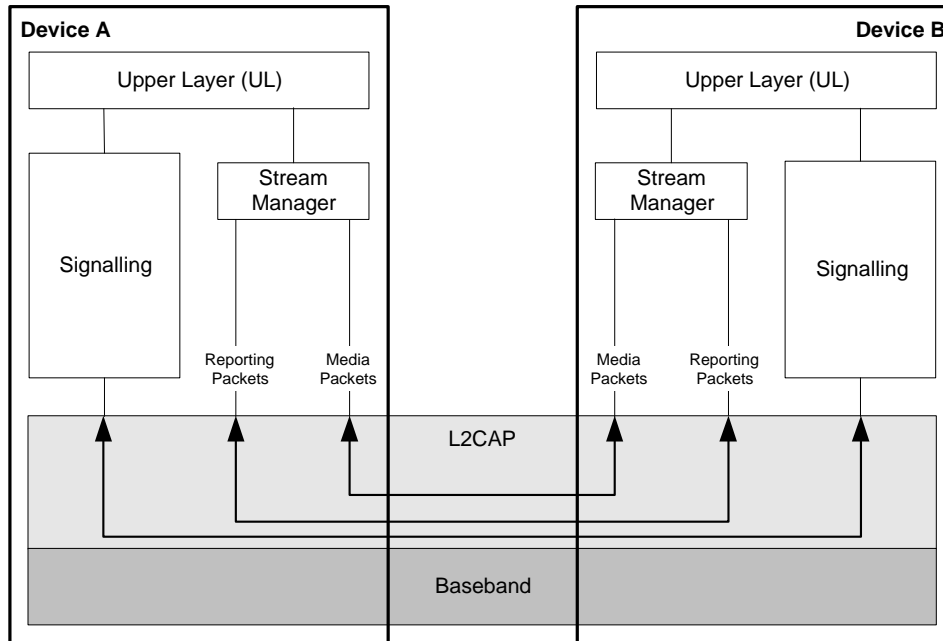

Figure 7.3: Transport Channels for Media Transport and Reporting

Media and Reporting use L2CAP directly. RTP realizes transport of the A/V data stream on L2CAP, and RTCP monitors the Quality of Service and conveys necessary information about the participants in the ongoing transport session.

This solution makes use of different transport sessions for reporting and media transport. Each channel carries different packet formats depending on the different type of transport sessions (audio, video, etc.). Different media transport sessions **may** be opened for the same single video application; each stream corresponds to one of the media streams (object, enhancement layer, etc.). For each opened media transport session, a reporting channel **shall** be associated. Therefore, a stream session **shall** include two transport channels, one for Media packets and the other one for Reporting packets.

In AVDTP, only SR, RR and SDES **shall** be used. They are described in the following sections. For more information, see RFC1889 [3].

7.3.1 Sender Report Reporting packet (SR)

Figure 7.4 shows Sender Report packet. It consists of three sections, possibly followed by a fourth profile-specific extension section if defined. The first section, the header, is eight octets long.

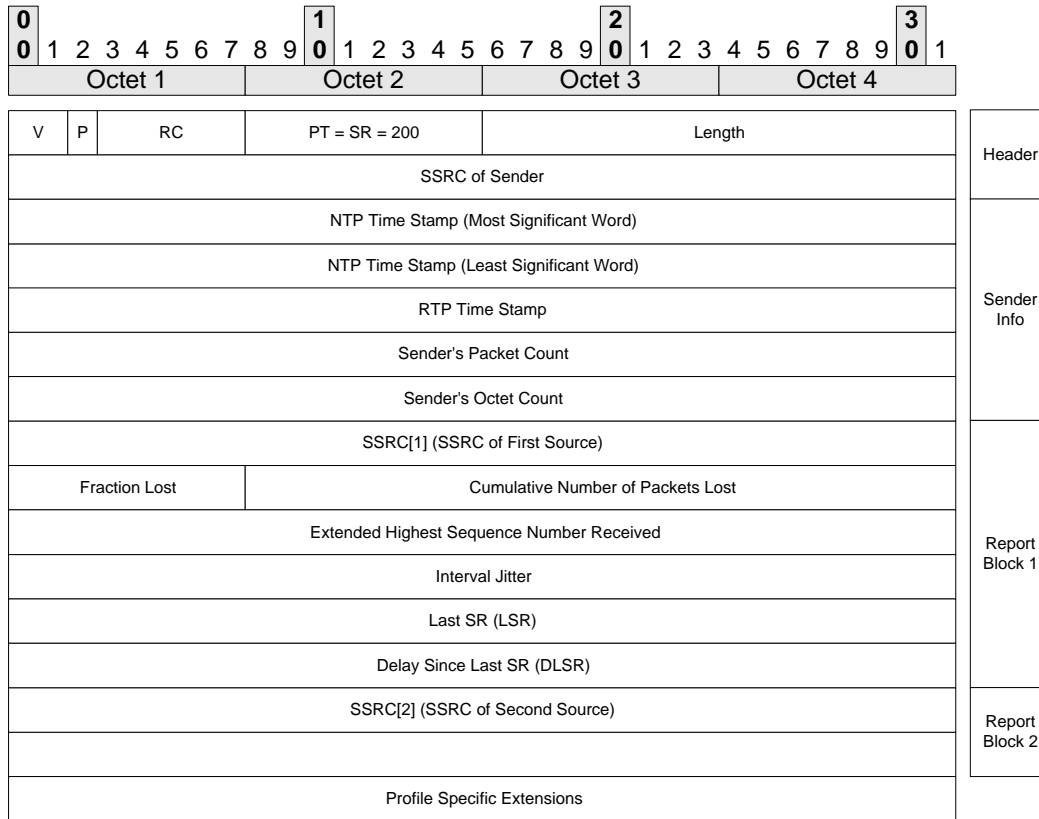

Figure 7.4: SR Reporting packet Format

The information elements are described in [Table 7.2](#).

Information Element	Description	Length
Version (V)	See Table 7.1	
Padding (P)	See Table 7.1	
Reception Report Count (RC)	The number of reception report blocks contained in this packet.	5 Bits
Packet Type (PT)	Contains the constant 200 to identify this as an RTCP SR packet.	8 Bits
Length	The length of this RTCP packet in 32-bit words minus one, including the header and any padding.	16 Bits
SSRC	See Table 7.1	
NTP Time Stamp	Indicates the wall clock time when this report was sent so that it may be used in combination with timestamps returned in reception reports from other receivers to measure round-trip propagation to those receivers.	64 Bits
RTP Time Stamp	Corresponds to the same time as the NTP timestamp (above), but in the same units and with the same random offset as the RTP timestamps in data packets.	32 Bits
Sender's Packet Count	The total number of RTP data packets transmitted by the sender since starting transmission up until the time this SR packet was generated.	32 Bits
Sender's Octet Count	The total number of payload octets (i.e., not including header or padding) transmitted in RTP data packets by the sender since starting transmission up until the time this SR packet was generated.	32 Bits
SSRC_n (Source Identifier)	The SSRC identifier of the source to which the information in this reception report block pertains.	32 Bits
Fraction Lost	The fraction of RTP data packets from source SSRC_n lost since the previous SR or RR packet was sent, expressed as a fixed-point number with the binary point at the left edge of the field.	8 Bits
Cumulative Number of Packets Lost	The total number of RTP data packets from source SSRC_n that have been lost since the beginning of reception.	24 Bits
Extended Highest Sequence Number Received	The low 16 bits contain the highest sequence number received in an RTP data packet from source SSRC_n, and the most significant 16 bits extend that sequence number with the corresponding count of sequence number cycles.	32 Bits
Inter-arrival Jitter	An estimate of the statistical variance of the RTP data packet inter arrival time, measured in timestamp units and expressed as an unsigned integer.	32 Bits
Last SR Timestamp (LSR)	The middle 32 bits out of 64 in the NTP timestamp received as part of the most recent RTCO sender report (SR) packet from source SSRC_n.	32 Bits

Delay since Last SR (DLSR)	The delay, expressed in units of 1/65536 seconds, between receiving the last SR packet from source SSRC_n and sending this reception report block.	32 Bits
----------------------------	--	---------

Table 7.2: Reporting Packets Information Elements (taken from [3])

7.3.2 Receiver report packet (RR)

The format of the Receiver Report (RR) packet is the same as that of the SR packet except that the Packet Type (PT) field contains the constant 201 and the five words of sender information are omitted.

7.3.3 Source description packet (SDES)

Each chunk consists of an SSRC or a CSRC identifier followed by a list of zero or more items, which carry information about the SSRC or CSRC.

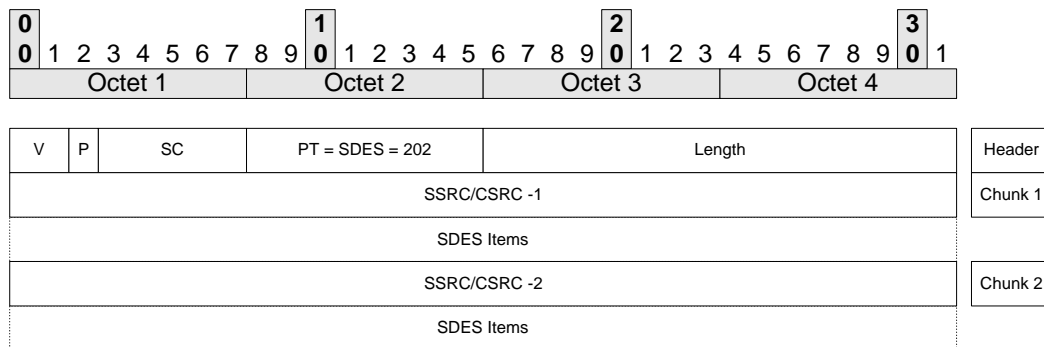

Figure 7.5: SDES reporting packet format

Information Element	Description	Length
Version (V)	See Table 7.1	
Padding (P)	See Table 7.1	
Source Count (SC)	The number of SRC/CSRC chunks contained in this SDES packet.	5 Bits
Packet Type (PT)	Contains the constant 202 to identify this as a Reporting SDES packet.	8 Bits
Length	See Table 7.2	
SSRC_n (Source Identifier)	See Table 7.2	

Table 7.3: SDES Reporting Packets Information Elements (taken from [3])

There are eight SDES items currently defined by RFC1889 [3]. Figure 7.6 is the CNAME item (the Canonical end-point identifier SDES item) as one example from the SDES items. Because the randomly allocated SSRC identifier **may** change if a conflict is discovered or if a program is restarted, the CNAME item is required to provide the binding from the SSRC identifier to an identifier for the source that remains constant.

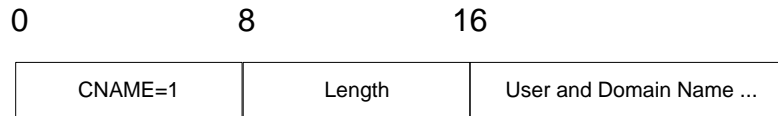

Figure 7.6: CNAME - Canonical end-point identifier SDES item

7.3.4 Reporting Feedback

RTP senders and receivers provide reception quality feedback using report packets, Sender Report packets (SR) or Receiver Report packets (RR).

Let SSRC_r denote the receiver issuing this receiver report. Source SSRC_n **can** compute the round propagation delay to SSRC_r by recording the time A when his reception report block in the SR or RR is received. It calculates the total round-trip time A - LSR using the last SR timestamp (LSR) field in the report block, and then subtracting the delay since last SR (DLSR) field in the same report block to leave the round-trip propagation delay as (A - LSR - DLSR). This **can** be used as an approximate measure of distance to cluster receivers, although some links have very asymmetric delays.

7.4 Recovery Service

7.4.1 Scope

ACL links provide a selectable error correction service (FEC 2/3) in the baseband. This protection scheme **can** correct a single bit error in every 10-bits sequence used to generate the additional parity code. In principle baseband, FEC is always usable for the protection of AV stream data as well.

The baseband FEC is intended to limit the number of retransmissions needed in adverse radio transmissions: in the case that significant burst errors this feature does not help very much since the affected baseband packets are lost. In addition, the baseband FEC service is not selectable for each logical channel separately.

Usually the retransmission of the corrupted baseband packets is required to recover a lost media packet completely.

When retransmission is neither desirable nor applicable, a forward error correction scheme that protects media packets directly in the AV transport layer **can** be selected as an alternate recovery mechanism. An example of use is in configurations where the sink device operates in a lower power mode than the source device: here the piggybacked acknowledgement of the receiver could fail while the reception of the media packet itself by the same device was actually successful and retransmission is simply squandering.

One additional benefit of the recovery service is to provide the means for applications to differentiate the protection according to the media packet types or contents. For instance, an application **can** decide to protect either video packets or audio packets depending on their respective error-resilience capability or to limit the protection to some vulnerable parts of the stream.

The recovery service **shall** perform independently of the type of media packet to be protected and the underlying transport features.

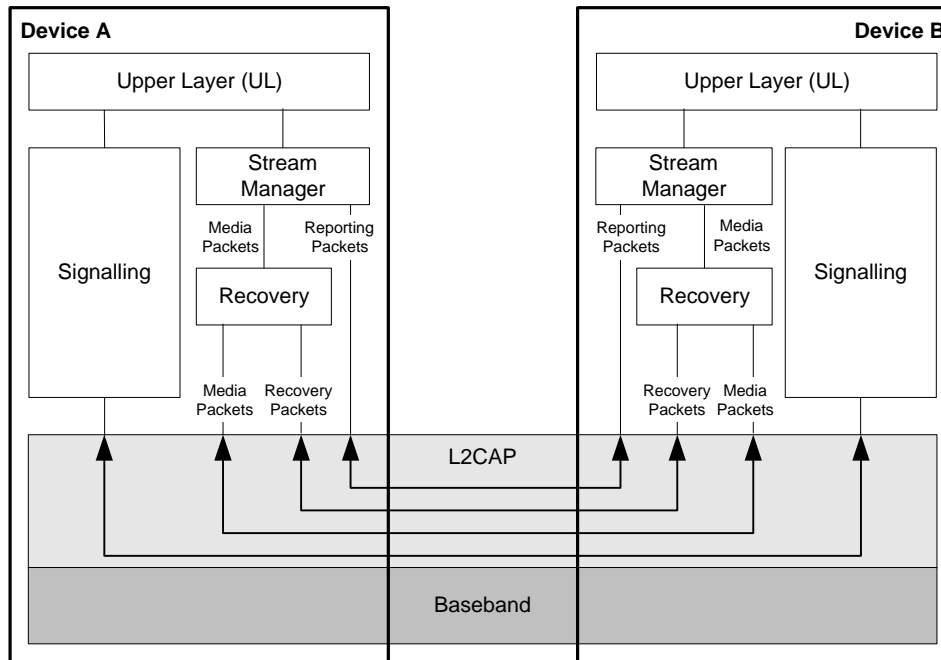

Figure 7.7: Transport Channels for Media Transport, Recovery, and Reporting

7.4.2 Overview

The recovery service is based on RFC2733 “An RTP Payload Format for Generic Error Correction” [4]. This document provides a complete specification of the packet format to be adopted for generation and encapsulation of the recovery service packets. It also mandates the procedures to be used for media packet reconstruction at the receiving side.

The recovery service operates independently of the other AVDTP services in a dedicated transport session. Once configured the service is permanently available to handle application requests for media packet protection in the following way:

- At the source side, the service is active on application demand through a specific interface. Recovery packets are generated from the set of media packets to be protected: generation rules are found in [4]. Then the generated recovery packets are automatically filed onto the associated transport channel without additional intervention of the application.
- At the sink side the service is directly triggered by the stream manager entity each time a missing media packet is detected in a protected transport session: the detection of a lost media packet is based on the sequence number control. The recovery service attempts to restore the missing packet using one or several subsequent recovery packets, which have the missing media packet in scope. If the original media packet is successfully reconstructed the recovery service calls a stream manager function back to insert the media packet at the stream output interface. If the recovery fails, the missing media packet is

signaled to the application and no data is streamed out for the lost packet. No intervention of the application is required during the active recovery phase. A complete specification of the procedure for the reconstruction of missing media packets **can** be found in [4].

7.4.3 Recovery transport channel

Conformant L2CAP implementations guarantee that subsequent L2CAP packets never share the same baseband payload even when fragmentation is applied: therefore the loss of a single baseband packet only affects a single transported L2CAP packet in the sequence.

To reduce the probability of simultaneous loss of media and recovery packets AVDTP **shall** encapsulate those packets as payload of individual L2CAP packets. This requirement is actually met when the transport channels are not configured for multiplexing. Implementations that combine multiplexing and recovery services in a source device require additional session and transport management to achieve it.

7.4.4 RTP payload type

The IETF document [4] leaves it up to the referring specification to require the transport of media and recovery packets in common or separate streams.

AVDTP requires that media and recovery packets be transported in separate sessions and/or channels. In the destination device, each payload is identified by its transport session and/or channel ID without the need of a distinct RTP payload type in the packet header.

For compliance with [4] a RTP payload type has to be selected and used for the transmission of the recovery packets between Bluetooth conformant devices: in AVDTP the RTP PT value of each recovery packet shall be set to the one of the source Media stream packet.

7.4.5 Session Description Protocol (SDP) requirements

All sections of [4] that refer to the Session Description Protocol (SDP) [8] are not applicable for this specification.

7.4.6 Real Time Streaming Protocol (RTSP) requirements

All sections of [4] that refer to the Real Time Streaming Protocol (RTSP) [7] are not applicable for this specification.

7.4.7 Parity codes

According to [4], the recovery packet payload includes an additional FEC header that provides identification of the protected media packet sequence through a base sequence number and a mask. This identification method extends the coverage window over 24 media packets starting from the indicated base packet.

The combination of a set of media packets used to generate the recovery packet(s) is called a parity code. Any parity code **can** be used: by means of the base sequence

number and the mask information in the recovery packet header the sink device **can** always reconstruct one or more lost packets depending on the used parity code.

As the parity code information is contained in the recovery packet headers, no signaling or configuration of the channel for a peculiar parity code usage is required. A source device **can** dynamically adapt the parity code to the channel condition without the use of additional out of band signals. Selection of the best suitable parity codes, depend on the measured traffic conditions and is left to the application.

7.4.8 Recovery Window

Depending on the used parity code, the generation of a single recovery packet is achieved at the source side by picking some media packets up from the sequence and generating a primary parity packet from this covered set.

Depending on the complexity of the coding scheme the reconstruction of any original media packet at the sink side requires some combination of recovery packets and media packets and follows the recovery procedures specified in [4]. As cascaded operations **can** be required to recover some media packet the length of the packet sequence needed to recover a single media packet loss at the sink side **can** be larger than the number of original packets used to generate the recovery packet at the source side.

The recovery window size is the number of media packets the sink device **can** buffer to guarantee the reconstruction of any single packet of the covered sequence.

INT and ACP **shall** negotiate the maximum recovery window size during the SEP configuration procedure. During streaming the source device **can** only select coding schemes that are compatible with the configured value.

Limiting the window size tends also to reduce the potential latency and jittering effects when a corrupted packet needs to be recovered.

7.4.9 Recovery SEP capabilities

In order to cope with possible resource limitations of the source and sink devices the following capabilities are exposed and configured in the context of the recovery service:

- Maximum size of the recovery window, the sink side **shall** allocate to ensure the reconstruction of any single media packet. The range is 1...24
- Maximum number of media packets that **can** be used to compute a recovery packet. The range is 1 to 24. A value of 1 means that the service actually operates as an on-demand packet retransmission service.

To serve the sink device correctly with respect to the negotiated recovery window the source device is mandated to schedule each recovery packet transmission immediately after the last original packet used in the parity code generation.

7.4.10 Applicable coding schemes

All coding schemes in [4] that are compatible with the stream end-point capabilities **can** be used by the source device. Selection of an optimal coding scheme depends on

application strategies and device capabilities. Criteria of selection **can** also vary along the session.

- The lower the number of media packets used to generate a single recovery packet, results in a higher probability of a lost media packet. The reason is that the service fails to reconstruct the original packets, if multiple packet loss occurs in a covered set.
- Applying sporadic coding scheme or changing schemes on the fly can be used to modulate the packet protection in a selective way. This is useful to reduce the total overhead and is more specifically applicable when the source of the media stream uses encoding methods that perform bit classification.

One of the suggested schemes [parity code scheme 2 in [4], sec. 4] makes it possible for encoding and transmitting of recovery packets only. This scheme allows for recovery of single packet losses and some consecutive packet losses with a minimum overhead at the expense of additional processing power. Using such scheme requires that each media packet – corrupted or not - **shall** be reconstructed from some subsequent recovery packets.

7.4.11 Unsystematic coding schemes

Unsystematic coding schemes are those where the receiver generates parity packets that enable the receiver to reconstruct all the original media packets. No media transport is negotiated and the receiver **shall** decode the parity packets to derive the media packets. Therefore unsystematic coding schemes are applicable if and only if a recovery session has been successfully configured while the INT did not request a media session at stream configuration time.

7.5 Multiplexing Service

The Multiplexing Service, which is conceptually located in the Adaptation Layer of AVDTP (AVDTP-AL), is characterized by a more flexible usage of the underlying transport channels (L2CAP channels) and its packets (L2CAP packets). It is possible to improve the efficiency of the lower layer packet usage. This is achieved by enabling fragmentation, as part of multiplexing, within the Adaptation Layer.

Enabling the Multiplexing Service **shall** be configured during the Stream Configuration Procedure, see § 6.6. In particular, if an application intends e.g. to have 2 streams, which are established sequentially, to share the same transport channel, the Multiplexing Service **shall** be configured for both of them from the beginning.

7.5.1 Adaptation Layer PDU packet format

When the multiplexing mode is not configured, an L2CAP payload, which means a PDU of AVDTP, consists of a single media, reporting, or recovery packet, and each transport session of AVDTP uses a different transport (L2CAP) channel. These restrictions are released in the Multiplexing Service. In other terms, an AL-PDU, i.e. a PDU of the AVDTP-AL incorporating Multiplexing Service, **may** comprise one or multiple packets (media, reporting, or recovery packets), i.e. multiplexed packets **may** belong to different transport sessions and even different streams. This implies that in Multiplexing Service,

an additional header (AL header) is needed, which encapsulates each packet contributing to an AL_PDU. The AL header provides framing of the variable length transport (media/reporting/recovery) packets and ensures a correct mapping to the associated transport session at the sink side.

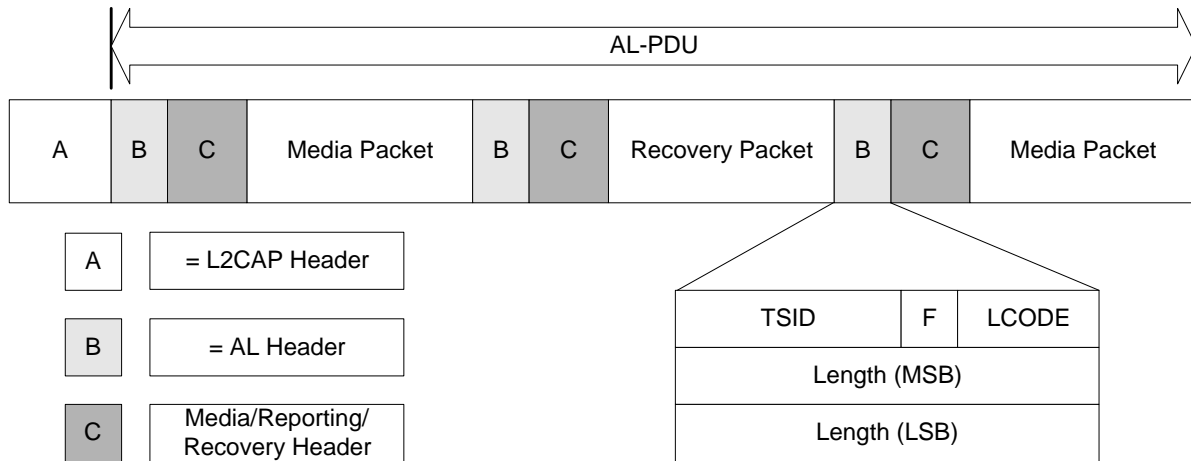

Figure 7.8: Adaptation Layer Packet Format

The format of the AL-PDU is depicted in Figure 7.8. In this example, two media packets and one recovery packet are contained within the AL-PDU. In general, the sequence of media/reporting/recovery packets in an AL-PDU is arbitrary and dynamic. It is in the responsibility of the source AVDTP-AL entity to serve the different transport sessions and to fill AL-PDU in an appropriate way. In doing so it **can** e.g. consider expected packet sizes at lower layers, thus help to improve the bandwidth exploitation of the Bluetooth link.

Nevertheless, some restrictions **should** be considered. Media and reporting packets involved in the same recovery operation (see § 7.4) **should** not be packed into the same AL-PDU.

A more instructive example of the Multiplexing Service is given in § 14

7.5.2 Adaptation Layer Header format

The format and contents of the Adaptation Layer header (AL header) is given in Figure 7.8 and Table 7.4.

Information Element	Description	Length	Possible Values
TSID	Transport Session Identifier see definition in § 4.13	5 Bits	00000 = Indicates an extension of the AL header: in case of TSID=00000, a second AL header byte, before the length field, is expected and contains the actual TSID, aligned with MSB.
F	Adaptation Layer Fragmentation	1 Bit	0 = Un-fragmented transport packet. 1 = Data following represent continuation chunk of transport packet.
LCODE	Coding of length field	2 Bits	00 = No length field present 01 = 16 bit length field (in 2 length octets following) 10 = 9 bit length field, MSB = 0, 8 LSBs in 1 octet following 11 = 9 bit length field, MSB = 1, 8 LSBs in 1 octet following

Table 7.4: Adaptation Layer Header Information Elements

In the header the TSID is used to route packets at sink side to the correct transport session, i.e. media, reporting, or recovery part transport session of a certain stream. Note the TSID scope is across sessions for media/reporting/recovery packets of one or multiple streams between a given pair of devices.

The variable length field encoding serves to minimize the overhead while accommodating typical packet lengths (e.g. 9 bits needed to fit DH5 packet length). LCODE=00 (no length field present) **can** be used to save at least one byte per L2CAP packet. In the last transport packet within an AL-PDU, a length field is not needed because the overall length of the AL-PDU is indicated in the L2CAP header.

Consequently, the AL header spans a minimum of one byte, a typical length of 2 bytes (one length byte present) and, without extension mechanism, a maximum of 3 bytes.

7.5.3 Adaptation Layer Fragmentation

The source side AVDTP-AL **may** choose to use slot capacity more efficiently, by starting a transport packet in the end of an L2CAP payload (end of AL-PDU) and continuing it in a following AL-PDU. This mechanism is called Adaptation Layer Fragmentation.

- The starting segment **shall** be the last transport packet within an AL-PDU, with the length field indicating the original length of the un-fragmented transport packet. Though F=0 for the starting segment, the sink side AVDTP-AL recognizes the fragmentation by the length exceeding the AL-PDU packet boundary, and expects the transport packet to be continued in the *next* AL-PDU segment belonging to the *same* transport session.

- The continuation segment of a fragmented transport packet is marked by F=1. Its length field indicates the actual segment length.
Exception: this segment ranges in the end of the AL-PDU again and is meant to continue in yet another AL-PDU; in this case, the length field contains the length of all remaining segments of the fragmented transport packet.
- Both the SRC and the SNK **shall** be aware that there are rare constellations where a loss of fragments cannot be detected immediately.

7.6 Robust Header Compression Service

This service is based on ROHC, robust header compression, which **can** be found in the IETF RFC [5]. The IETF standard includes compression of IP, UDP, and the RTP header. Within the AVDTP protocol, only the RTP compression part is used.

The following sections describe the modifications of IETF RFC [5] (ROHC) that are required when used in conjunction within AVDTP. The changes are required because no IP or UDP headers are contained in packets transported with AVDTP.

7.6.1 CRC Calculation

In all packets, the CRC is calculated using only the static and dynamic fields of the uncompressed RTP header.

7.6.2 Per-Channel Parameters

As the multiplexing of transport sessions, in Multiplexing Mode only, is achieved by a separate AVDTP mechanism (see § 7.5), context ID numbers are not needed in AVDTP. Therefore, LARGE_CIDS= false is set. This setting covers the option to use no prefix byte at all; i.e., implicit CID=0.

7.6.3 Feedback Channel

For the ROHC feedback in AVDTP, the following choices exist:

- No back-channel is used at all (the sink device chooses not to request transition from U-mode to O/R-mode, e.g. if it prefers to use the slots for other traffic, or it is a multicast configuration).
- The reverse direction (upstream) of the same transport session is used for ROHC feedback. The same mapping of transport session and transport channel is valid as for the downstream transfer.

7.6.4 Packet Types

Packet Type	Description
IP-ID Packets	The UOR-1-ID, UOR-1-TS, UOR-2-ID, and UOR-2-TS packet types are not valid in AVDTP since there cannot be any IP-ID to transmit.
Extension Format 3 in UOR-2 Packets	In the header, the options "I" and "ip" shall have the value 0. As the RTP mixer functionality is not used in AVDTP, compression of CSRC lists is not necessary, such that the "CSRC" option takes the value 0.

8 Signaling Messages

8.1 Stream Configuration Procedure

Service Capabilities of each SEP **can** be discovered using signaling commands such as AVDTP_DISCOVER_CMD and AVDTP_GET_CAPABILITIES_CMD. Service Capabilities are selected using AVDTP_SET_CONFIGURATION_CMD. The selected Service Capabilities are valid for the SEID. To retrieve the Service Capabilities of the SEP AVDTP_GET_CONFIGURATION_CMD is used.

Procedure to make a SEP connection is as follows.

1. Discover stream end-points within an ACP, using AVDTP_DISCOVER_CMD
2. Select Stream End Point
3. Collect Service Capabilities of the target SEID using AVDTP_GET_CAPABILITIES_CMD
4. Select the Capabilities on the target device for the SEP using AVDTP_SET_CONFIGURATION_CMD.

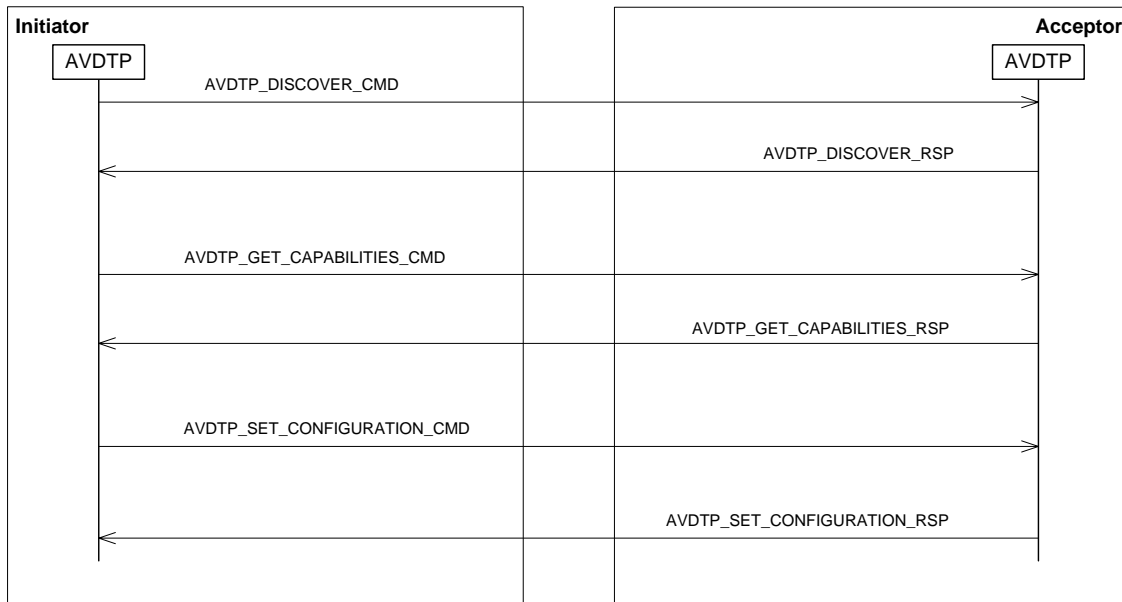

Figure 8.1: Example of the Service Capabilities negotiation procedures

8.2 Signaling Message format

This section defines the structure of the signaling messages used to gather information on stream capabilities and media stream establishment.

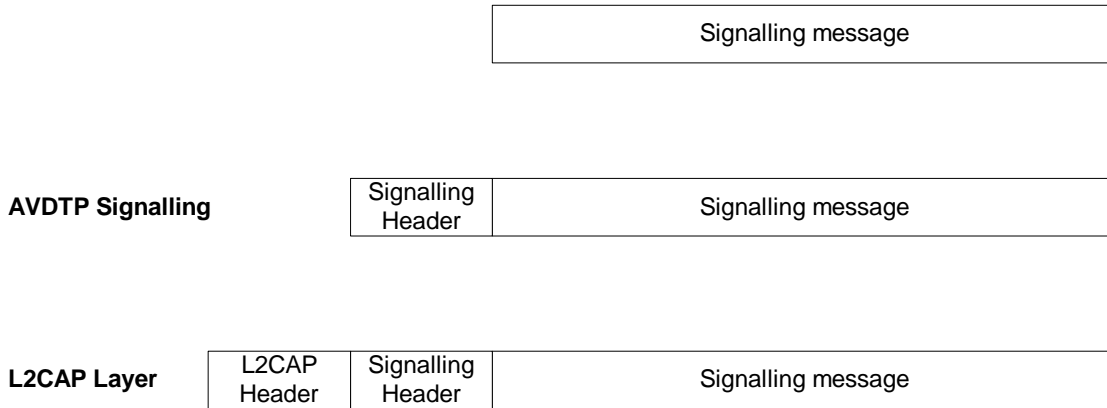

Figure 8.2: Packet format for signaling message (Single L2CAP packet)

Figure 8.2 show a signaling message process as it passes down the layers. A signal request arrives at AVDTP from the Upper Layer. AVDTP formats the request and adds AVDTP signaling header. The AVDTP signaling message is then passed to L2CAP for transportation to the peer. Only one AVDTP signaling message is allowed in one L2CAP packet.

8.3 Signal Fragmentation

Among others fragmentation and reassembly of signaling messages **can** be needed to cope with the MTU requirements of the receiving unit.

Figure 8.3, shows how a large signal is fragmented as it travels through the layers. A request is sent from the Upper Layer to send a signal to the peer AVDTP signaling entity. When AVDTP receives the request, the request is formatted accordingly, ready for transmission to the peer AVDTP entity. AVDTP then splits the signal into suitable size packets, ready for transmission.

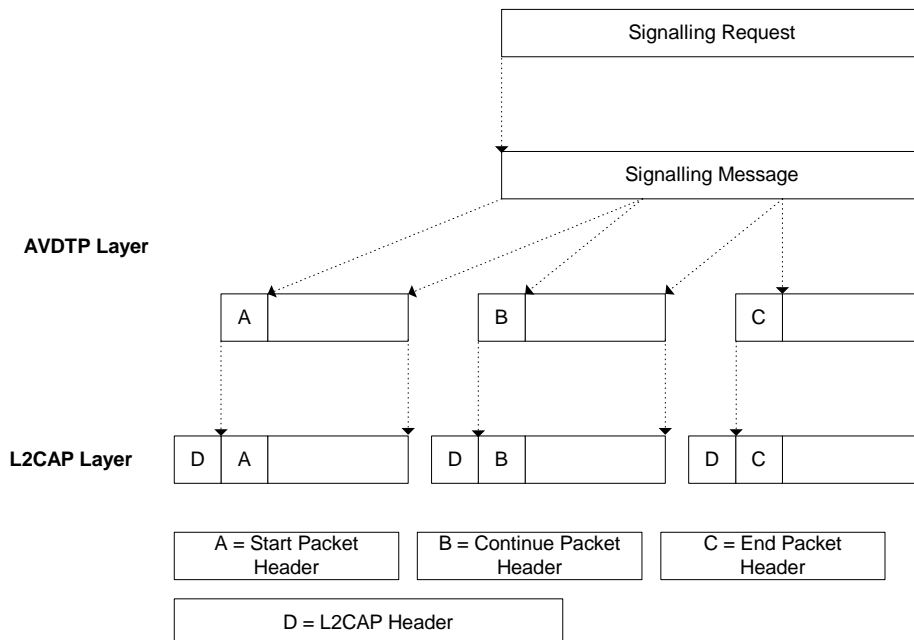

Figure 8.3: Packet format for signaling message (Multi L2CAP packets)

The first packet is a Start Packet and is formatted as in Figure 8.5. The packets that follow the Start Packet are termed as Continue Packets and are formatted as in Figure 8.6, when the last packet of the signal is reached it is formatted as in Figure 8.6. Each packet type is sent in a single L2CAP packet.

The sender is mandated to transmit sequentially all packets belonging to same message before handling the packets from the next message; in other words interleaving of packets from different messages on the air is not allowed.

Note that it is permitted to breakdown a packet sequence (command or response message) to send an Abort command message in the same direction. The remaining packets consecutive to an aborted message **shall** be flushed by the sender.

8.4 Signal command and response headers

Shown below are the formats of the general signaling command and response signals. To enable the use of large size signals two header formats are used. One format provides information elements to identify the start of a fragmented signal and the length of the signal. The other provides information elements suitable for continue, end and single packets.

7	6	5	4	3	2	1	0	Octet
Transaction Label				Packet Type		Message Type		0
RFA		Signal Identifier						1

Figure 8.4: Signaling message format for single packets

7	6	5	4	3	2	1	0	Octet
Transaction Label				Packet Type		Message Type		0
NOSP = Number Of Signal Packets see § 8.18.4								1
RFA		Signal Identifier						2

Figure 8.5: Signaling message format for start packets

7	6	5	4	3	2	1	0	Octet
Transaction Label				Packet Type		Message Type		0

Figure 8.6: Signaling message format for continue and end packets

8.4.1 Transaction Label

The Transaction Label specifies a unique tag for each outstanding transaction from INT. The transaction label field is four bits in length. On the ACP side, the transaction label received in a signaling command frame **shall** be used as the transaction label returned in the corresponding signaling response frame.

8.4.2 Packet Type

Signaling messages **shall** be fragmented by the sender when they are oversized regarding the MTU requirement of the channel. The sender **may** also decide to fragment a message to save resources on its part. This field indicates that signaling message consists of single packet or multi packets. In the multi packets case, this field also indicates the Packet Type of the signaling message (start packet, continue packet or end packet).

2 Bits		
3	2	
0	0	Single Packet
0	1	Start Packet
1	0	Continue Packet
1	1	End Packet

Table 8.1: Packet Type field values

8.4.3 Message Type

On each command packet, the Message Type field specifies the command type of the signaling command. On each signaling response packet, the Message Type field specifies the result of corresponding signaling command on ACP.

2 Bits		
1	0	
0	0	Command
0	1	RFD
1	0	Response Accept
1	1	Response Reject

Table 8.2: Message Type field values

8.4.4 Signal Identifier

The Signal Identifier field indicates the signaling command from INT to ACP. On the ACP side, the Signal Identifier field value received in a signaling command message **shall** be used as the Signal Identifier field value in the corresponding signaling response message.

8.4.5 Packet size requirements

The receiver of a fragmented message **may** allocate the resources for message reassembly based on the start packet length and the number of packets information elements provided by the first packet. For this reason:

1. The L2CAP payload of the start and all continue packets of a fragmented message **shall** have the same length

2. The L2CAP payload of end packets **shall** not be larger than the start and any possible continue packet that belong to the same message.

8.4.6 Message integrity verification at receiver side

The receiver of an AVDTP signaling message **shall** not interpret or pass corrupted messages to the upper layer. Those messages are discarded and not signaled to the local upper layer; no signaling message is returned to the sender. Possible corrupted messages are:

- Response messages where the transaction label cannot match a previous command sent to the remote device
- All incoming messages with the message type set to RFD
- Messages with an unexpected packet type in the sequence (e.g. a first packet having a packet type field set to 'continue' or 'end')
- Incomplete fragmented messages (the number of received packet does not match the value of the NOSP field in the start packet)

8.5 Signaling command set

In this section, signaling command and responses are defined. The signaling message format is shown in § 8.2.

The detail encoding of signal command and response information elements are described in following sections. [Table 8.3](#) defines the signal identifier field value (see § 8.17 for definition of field) for each signaling message. The signal format and information elements are specified in the following sections.

Signal Identifier	Value	Cross Reference
AVDTP_DISCOVER	0x01	8.6.1, 8.6.2, 8.6.3
AVDTP_GET_CAPABILITIES	0x02	8.7.1, 8.7.2, 8.7.3
AVDTP_SET_CONFIGURATION	0x03	8.8.1, 8.8.2, 8.8.3
AVDTP_GET_CONFIGURATION	0x04	8.9.1, 8.9.2, 8.9.3
AVDTP_RECONFIGURE	0x05	8.10.1, 8.10.2, 8.10.3
AVDTP_OPEN	0x06	8.11.1, 8.11.2, 8.11.3
AVDTP_START	0x07	8.12.1, 8.12.2, 8.12.3
AVDTP_CLOSE	0x08	8.13.1, 8.13.2, 8.13.3
AVDTP_SUSPEND	0x09	8.14.1, 8.14.2, 8.14.3
AVDTP_ABORT	0x0A	8.15.1, 8.15.2
AVDTP_SECURITY_CONTROL	0x0B	8.16.1, 8.16.2, 8.16.3

Table 8.3: Signal Identifier field values

8.6 Stream End Point Discovery

8.6.1 Stream End Point Discovery Command

The AVDTP_DISCOVER_CMD is sent from INT to ACP and it requests to get the overview of all SEP information of the ACP.

7	6	5	4	3	2	1	0	Octet
Signaling Header see 8.4								0
RFA		AVDTP_DISCOVER						1

Figure 8.7: Stream End Point Discovery command message

8.6.2 Stream End Point Discovery Response

AVDTP_DISCOVER_RSP message is sent from ACP to INT as a response to AVDTP_DISCOVER_CMD. The response contains an overview of all stream end-points that the ACP supports. Note this information is only valid for one stream establishment procedure, as the streaming resources within the ACP are dynamic and could be used by other devices. The Media Type value returned for each SEP, is defined in the Bluetooth Assigned Numbers document, see [6]. There **shall** be at least one SEP in an AVDTP_DISCOVER_RSP.

7	6	5	4	3	2	1	0	Octet
Signaling Header see 8.4								0
RFA		AVDTP_DISCOVER						1
First ACP SEID						In Use	RFA	2
Media Type				TSEP	RFA			3
[Other ACP SEID Information (2 octets each)]								:

Figure 8.8: Stream End Point Discovery Response message format

8.6.3 Stream End Point Discovery Reject

7	6	5	4	3	2	1	0	Octet
Signaling Header see 8.4								0
RFA		AVDTP_DISCOVER						1
ERROR_CODE see § 8.18.6								2

Figure 8.9: Stream End Point Discovery Reject message format

8.7 Get Capabilities

8.7.1 Get Capabilities Command

AVDTP_GET_CAPABILITIES_CMD is sent from INT to ACP, and it is used to get specific information for a SEP of an ACP. The SEID field value specifies the target SEP within ACP.

7	6	5	4	3	2	1	0	Octet
Signaling Header see 8.4								0
RFA		AVDTP_GET_CAPABILITIES						1
ACP SEID					RFA			2

Figure 8.10: Get Capabilities Command message format

8.7.2 Get Capabilities Response

AVDTP_GET_CAPABILITIES_RSP message is sent from ACP to INT, and indicates the SEP capabilities requested by the corresponding AVDTP_GET_CAPABILITIES_CMD message from INT.

7	6	5	4	3	2	1	0	Octet
Signaling Header see 8.4								0
RFA		AVDTP_GET_CAPABILITIES						1
Service Capabilities see § 8.19								:

Figure 8.11: Get Capabilities Response message format

8.7.3 Get Capabilities Reject

After receiving an AVDTP_GET_CAPABILITIES_CMD from INT, the ACP tries to gather the Stream end-point capabilities. If the command fails, an AVDTP_GET_CAPABILITIES_REJ is sent back to the INT. The packet contains an error code as to why the command was rejected.

7	6	5	4	3	2	1	0	Octet
Signaling Header see 8.4								0
RFA		AVDTP_GET_CAPABILITIES						1
ERROR_CODE see § 8.18.6								2

Figure 8.12: Stream Get Capabilities Reject message format

8.8 Stream Configuration

8.8.1 Set Configuration Command

After receiving the AVDTP_GET_CAPABILITIES_RSP, INT selects the required SEP and its Service Capabilities for sending/receiving A/V stream to/from ACP. The INT notifies the selected SEP and its Service Capabilities to ACP by using AVDTP_SET_CONFIGURATION_CMD. AVDTP_SET_CONFIGURATION_CMD indicates all of required Service Capabilities for the SEP. The details of the Service Capabilities are defined in § 8.19.

7	6	5	4	3	2	1	0	Octet
Signaling Header see 8.4								0
RFA		AVDTP_SET_CONFIGURATION						1
ACP SEID					RFA			2
INT SEID					RFA			3
Service Capabilities see § 8.19 also see 0								:

Figure 8.13: Set Configuration Command message format

Any Service Capabilities Types can be present within this signal

8.8.2 Set Configuration Response

After receiving an AVDTP_SET_CONFIGURATION_CMD from INT, AVDTP_SET_CONFIGURATION_RSP packet is sent from ACP to INT.

7	6	5	4	3	2	1	0	Octet
Signaling Header see 8.4								0
RFA		AVDTP_SET_CONFIGURATION						1

Figure 8.14: Set Configuration Response message format

8.8.3 Set Configuration Reject

After receiving an AVDTP_SET_CONFIGURATION_CMD from INT, the ACP tries to configure the Stream end-point. If the configuration fails, an AVDTP_SET_CONFIGURATION_REJ is sent from ACP to INT. The packet contains a reject reason and details on why the command was rejected.

7	6	5	4	3	2	1	0	Octet
Signaling Header see 8.4								0
RFA		AVDTP_SET_CONFIGURATION						1
Service Category see Table 8.4 and 0								2
ERROR_CODE see § 8.18.6								3

Figure 8.15: Set Configuration Reject message format

NOTE Contains the value of the first Service Category to fail. In case no Service Category applies due to the nature of the error, the Service Category field **shall** be set to 0x0. The INT **should** ignore the Service Category if it is not applicable to the error code.

8.9 Get Stream configuration

8.9.1 Get Configuration Command

AVDTP_GET_CONFIGURATION_CMD is used to interrogate the current configuration of a stream end-point.

7	6	5	4	3	2	1	0	Octet
Signaling Header see 8.4								0
RFA		AVDTP_GET_CONFIGURATION						1
ACP SEID					RFA			2

Figure 8.16: Get Configuration Command message format

8.9.2 Get Configuration Response

When an ACP receives, an AVDTP_GET_CONFIGURATION_CMD AVDTP_GET_CONFIGURATION_RSP is sent back to the INT. The response contains the current configuration of the requested stream end-point.

7	6	5	4	3	2	1	0	Octet
Signaling Header see 8.4								0
RFA		AVDTP_GET_CONFIGURATION						1
Service Capabilities see § 8.19 also see Note 1								:

Figure 8.17: Get Configuration Response message format

Note 1. All Service Capabilities Types **can** be present within this signal

8.9.3 Get Configuration Reject

When an ACP receives, an AVDTP_GET_CONFIGURATION_CMD and there has been an error in processing the request then an AVDTP_GET_CONFIGURATION_REJ is sent back to the INT. The response contains a reject reason as to why the command was rejected.

7	6	5	4	3	2	1	0	Octet
Signaling Header see 8.4								0
RFA		AVDTP_GET_CONFIGURATION						1
ERROR_CODE see § 8.18.6								2

Figure 8.18: Get Configuration Reject message format

8.10 Stream Reconfigure

8.10.1 Reconfigure Command

Devices participating within a stream can change Application Service Capabilities. If a device wants to reconfigure Application Service Capabilities, an AVDTP_RECONFIGURE_CMD is used. The device that issues the command becomes the INT.

7	6	5	4	3	2	1	0	Octet
Signaling Header see 8.4								0
RFA		AVDTP_RECONFIGURE						1
ACP SEID					RFA			2
Service Capabilities see § 8.19 also see Note 2								:

Figure 8.19: Reconfigure Command message format

Note 2. Only Media Codec Capabilities see § 8.19.5 and Content Protection Capabilities see § 8.19.6 can be present within this signal.

8.10.2 Reconfigure Response

When the ACP receives an AVDTP_RECONFIGURE_CMD the stream is reconfigured with the provided configuration parameters. Upon a successful reconfiguration of the stream, an AVDTP_RECONFIGURE_RSP is sent back to the INT.

A Reconfigure command has a limited scope: only the Application Service Capabilities can be addressed for reconfiguration once the stream is open. For instance, if the reconfigure command addresses the Media Transport Capabilities the ACP shall return a reject message with an 'INVALID_CAPABILITIES' ERROR_CODE.

7	6	5	4	3	2	1	0	Octet
Signaling Header see 8.4								0
RFA		AVDTP_RECONFIGURE						1

Figure 8.20: Reconfigure Response message format

8.10.3 Reconfigure Reject

If the ACP cannot reconfigure the stream, then an AVDTP_RECONFIGURE_REJ is sent back to the INT. The reject signal contains an error code as to why the request was rejected.

7	6	5	4	3	2	1	0	Octet
Signaling Header see 8.4								0
RFA		AVDTP_RECONFIGURE						1
Service Category see Table 8.4 and Note 3								2
ERROR_CODE see § 8.18.6								3

Figure 8.21: Reconfigure Reject message format

Note 3. Contains the value of the first Service Category to fail.

8.11 Stream Establishment

The following sections define signals used to establish and close stream end-points. Information elements within the signals are defined in § 8.17

8.11.1 Open Stream Command

AVDTP_OPEN_CMD is used to the establish transport channels for a configured SEP. The INT opens the stream, and if necessary, the associated Transport Channels. In case Multiplexing Mode is required explicit Transport Session Identifiers shall be supplied with the associated Transport Channel Identifiers during the AVDTP_SET_CONFIGURATION_CMD message see § 8.8

7	6	5	4	3	2	1	0	Octet
Signaling Header see 8.4								0
RFA		AVDTP_OPEN						1
ACP SEID						RFA		2

Figure 8.22: Open Stream Command message format

8.11.2 Open Stream Response

After receiving the AVDTP_OPEN_CMD from INT, AVDTP_OPEN_RSP is sent from ACP to INT. This response signals to the INT that the stream is open.

7	6	5	4	3	2	1	0	Octet
Signaling Header see 8.4								0
RFA		AVDTP_OPEN						1

Figure 8.23: Open Stream Response message format

Upon reception of AVDTP_OPEN_RSP, the INT sets up the lower transport (L2CAP) channels as required by the configured service. If Multiplexing Service is not configured, individual transport channels for each transport session are established as specified in [1]. If Multiplexing Service is configured, new transport channels are only established if necessary, in accordance with the configuration settings.

8.11.3 Open Stream Reject

After receiving AVDTP_OPEN_CMD from INT, the ACP verifies if a stream connection can be established according to the configured service for the stream connection (e.g. in case of Multiplexing Service, if the mapping of TSIDs and TCIDs is possible. This reject contains an error code as to why the command was rejected).

7	6	5	4	3	2	1	0	Octet
Signaling Header see 8.4								0
RFA		AVDTP_OPEN						1
ERROR_CODE see § 8.18.6								2

Figure 8.24: Open Stream Reject message format

8.12 Stream Start

8.12.1 Start Stream Command

After receiving AVDTP_START_CMD from INT, the ACP puts the stream into streaming, ready to accept streaming media.

7	6	5	4	3	2	1	0	Octet
Signaling Header see 8.4								0
RFA		AVDTP_START						1
First ACP SEID						RFA		2
[Other ACP SEIDs]						RFA		:

Figure 8.25: Start Stream Command message format

8.12.2 Start Stream Response

After receiving AVDTP_START_CMD from INT, the ACP puts the stream(s) into streaming mode, ready to accept streaming media. AVDTP_START_RSP is sent back to the INT. This response contains an acknowledgement that the stream(s) have been started.

7	6	5	4	3	2	1	0	Octet
Signaling Header see 8.4								0
RFA		AVDTP_START						1

Figure 8.26: Start Stream Response message format

8.12.3 Start Stream Reject

After receiving AVDTP_START_CMD from INT, the ACP attempts to put the stream(s) into streaming mode, ready to accept streaming media. If any of the streams fail to start then an AVDTP_START_REJ is sent back to the INT. This reject contains an error code as to why the command has been rejected.

7	6	5	4	3	2	1	0	Octet
Signaling Header see 8.4								0
RFA		AVDTP_START						1
ACP SEID see Note 4						RFA		2
ERROR_CODE see § 8.18.6								3

Figure 8.27: Start Stream Reject message format

NOTE: Contains the value of the first SEP's SEID that failed. The ACP shall process the SEPs in the order they are listed in the Start Stream Command and stop processing when the first error occurs.

8.13 Stream Release

8.13.1 Close Stream Command

AVDTP_CLOSE_CMD requests can be sent by any device participating within a stream. The device that initiates the stream closure takes the role of INT. When the INT issues AVDTP_CLOSE_CMD the ACP, after receiving the command, shall act on the AVDTP_CLOSE_CMD and close its own references to the stream end-point.

7	6	5	4	3	2	1	0	Octet
Signaling Header see 8.4								0
RFA		AVDTP_CLOSE						1
ACP SEID						RFA		2

Figure 8.28: Close Stream Command message format

8.13.2 Close Stream Response

After receiving AVDTP_CLOSE_CMD from INT, AVDTP_CLOSE_RSP is sent from ACP to INT. This response contains an acknowledgement that the stream is closed within the ACP.

7	6	5	4	3	2	1	0	Octet
Signaling Header see 8.4								0
RFA		AVDTP_CLOSE						1

Figure 8.29: Close Stream Response message format

8.13.3 Close Stream Reject

If an AVDTP_CLOSE_CMD is sent by INT and the stream cannot be closed then an AVDTP_CLOSE_REJ is sent back to the INT indicating why the stream could not be closed.

7	6	5	4	3	2	1	0	Octet
Signaling Header see 8.4								0
RFA		AVDTP_CLOSE						1
ERROR_CODE see § 8.18.6								2

Figure 8.30: Close Stream Reject message format

8.14 Stream Suspend

8.14.1 Suspend Command

After receiving AVDTP_SUSPEND_CMD from INT, the ACP suspends the required stream(s).

7	6	5	4	3	2	1	0	Octet
Signaling Header see 8.4								0
RFA		AVDTP_SUSPEND						1
First ACP SEID						RFA		2
[Other ACP SEIDs]						RFA		:

Figure 8.31: Suspend Command message format

8.14.2 Suspend Response

After receiving AVDTP_SUSPEND_CMD from INT, the ACP suspends streaming on the indicated streaming end-point(s). AVDTP_SUSPEND_RSP is sent back to the INT. This response is the acknowledgement that the stream(s) have been suspended.

7	6	5	4	3	2	1	0	Octet
Signaling Header see 8.4								0
RFA		AVDTP_SUSPEND						1

Figure 8.32: Suspend Response message format

8.14.3 Suspend Reject

After receiving AVDTP_SUSPEND_CMD from INT, the ACP attempts to suspend the stream(s), identified by the SEID(s). If any of the stream(s) fail to suspend, an AVDTP_SUSPEND_REJ is sent back to the INT. The reject contains the first SEID that could not be suspended and an accompanying error code, as to why the stream could not be suspended.

7	6	5	4	3	2	1	0	Octet
Signaling Header see 8.4								0
RFA		AVDTP_SUSPEND						1
ACP SEID see 0						RFA		2
ERROR_CODE see § 8.18.6								3

Figure 8.33: Suspend Reject message format

Indicates the first SEID that failed to be suspended.

8.15 Abort

8.15.1 Abort Command

During stream establishment, if either the device no longer wants to proceed, AVDTP_ABORT_CMD is used. The command signals that stream establishment is aborted. AVDTP_ABORT_CMD can be used in any state.

7	6	5	4	3	2	1	0	Octet
Signaling Header see 8.4								0
RFA		AVDTP_ABORT						1
ACP SEID					RFA			2

Figure 8.34: Abort Command message format

8.15.2 Abort Response

AVDTP_ABORT_RSP is sent on acknowledgment of an AVDTP_ABORT_CMD in case it contains a valid SEID. If an AVDTP_ABORT_CMD contains an invalid SEID, no response shall be sent.

7	6	5	4	3	2	1	0	Octet
Signaling Header see 8.4								0
RFA		AVDTP_ABORT						1

Figure 8.35: Abort Response message format

8.16 Security Control

8.16.1 Security Control Command

The Security Control Command is sent from the INT to ACP and is used to send content protection commands to ACP. The SEID field value specifies the target SEP in ACP.

7	6	5	4	3	2	1	0	Octet
Signaling Header see 8.4								0
RFA		AVDTP_SECURITY_CONTROL						1
ACP SEID					RFA			2
Content Protection Method Dependent Data								:

Figure 8.36: Security Control command message format

8.16.2 Security Control Response

Security Control Response is sent from ACP to INT in acknowledgement to a Security Control Command; it is also used for sending content protection control response to INT. The SEID field value specifies the target SEP in ACP.

7	6	5	4	3	2	1	0	Octet
Signaling Header see 8.4								0
RFA		AVDTP_SECURITY_CONTROL						1
Content Protection Method Dependent Data								:

Figure 8.37: Security Control response message format

8.16.3 Security Control Reject

7	6	5	4	3	2	1	0	Octet
Signaling Header see 8.4								0
RFA		AVDTP_SECURITY_CONTROL						1
ERROR_CODE see § 8.18.6								2

Figure 8.38: Security Control Reject message format

8.17 General Reject

General Reject message is used by an ACP to respond a command message that contains an invalid Signal Identifier.

7	6	5	4	3	2	1	0	Octet
Transaction Label				Packet Type		RFA		0
RFA								1

Figure 8.39: General Reject response format

8.18 Information Elements

The following sections define all the information elements used in the signaling messages.

8.18.1 Stream End-point Identifier (SEID, INT SEID, ACP SEID)

Description	This information element identifies a unique identifier for the SEP. In the course of stream session a local SEID at each side of the SEP connection. See definition in 4.10
Length	6 Bits
Possible Values	0x00 – Forbidden 0x01 – 0x3E valid SEID values 0x3F – RFD

A SEID is always assigned in the local space of the device. A device that initiates a signaling procedure to address a peculiar Stream End Point **shall** always use the remote device SEID assignment.

In the course of the **Discovery** procedure only the ACP device exposes its own SEID assignments to the INT device. When the roles change the original ACP wants in turn to initiate a signaling procedure to address the configured SEP for instance e.g. to start or

suspend the stream. To achieve it the original ACP device **shall** be aware of the SEID the original INT device has locally assigned to the addressed Stream End Point. This information **shall** be transmitted by the original INT device as an additional information element of the **AVDTP_SET_CONFIGURATION_CMD** message. Afterwards each end is able to address the Stream End Point using the remote device SEID.

In all signaling procedures **INT SEID** and **ACP SEID** refer to the SEID the device that plays the INT resp. ACP role in the context of this procedure has assigned.

8.18.2 Length of Service Capability (LOSC)

Description	A total length of the individual service capability. The LOSC field provides only the length of the service capability following this LOSC information element.
Length:	8 Bits
Possible Values	0x00 to 0xFF (In Octets)

8.18.3 Stream End-point Type, Source or Sink (TSEP)

Description	This field indicates if the stream end-point is SNK or SRC. The bit assignment of the TSEP field is shown below.
Length	1 Bit
Possible Values	0 = Stream End Point (SEP) is of type SRC 1 = Stream End Point (SEP) is of type SNK

8.18.4 Number of Signal Packets (NOSP)

Description	This information element indicates how many packets are present in a fragmented signaling packet.
Length:	8 Bits
Possible Values	0x01 to 0xFF

8.18.5 Stream End Point in Use (In Use)

Description	This information element indicates if a stream end-point is currently In Use or not.
Length:	1 Bit
Possible Values	0 = SEP is Not In Use 1 = SEP is In Use

8.18.6 Signaling Errors (ERROR_CODE)

AVDTP defines an 8-bits ERROR_CODE field transported over the air in signaling response messages when an ACP device rejects a signaling command message received from a distant INT device. The ERROR_CODE field received from an ACP device is exposed to the INT application through the AVDTP service interface.

According to this definition the ERROR_CODE information **can** only be reported in AVDT_*_Cfm events generated at the INT/AVDTP interface after receipt of a response message from the addressed ACP device in the correlated transaction.

This ERROR_CODE information is transported as cross-device information and **can** have different causes:

- ACP Application reject: the ACP application rejects a request it received from the remote INT side through a *_Ind event. For instance an ACP application **can** decide to reject the INT request due to insufficient resources or the request contains invalid application data (e.g. SEP identifier out of range).
- An ACP/AVDTP entity is not able to generate a valid *_Ind event to inform its local application of the reception of a command signal. For instance, the received signal identifier in the message is out of range.

Other error conditions reported to the application are local to the service call and therefore are out of the scope of the ERROR_CODE definition.

8.18.6.1 ERROR_CODE usage

- ACP application rejects an INT command signal

The application has received a valid request (AVDT_*_Req) from a remote device however the INT rejects the command. The reason for reject is indicated by the ERROR_CODE value. ACP/AVDTP encapsulates this ERROR_CODE value in a signalling reject message. On receipt of the reject message INT/AVDTP reports the ERROR_CODE value to the local application through the AVDT_*_Cfm event callback.

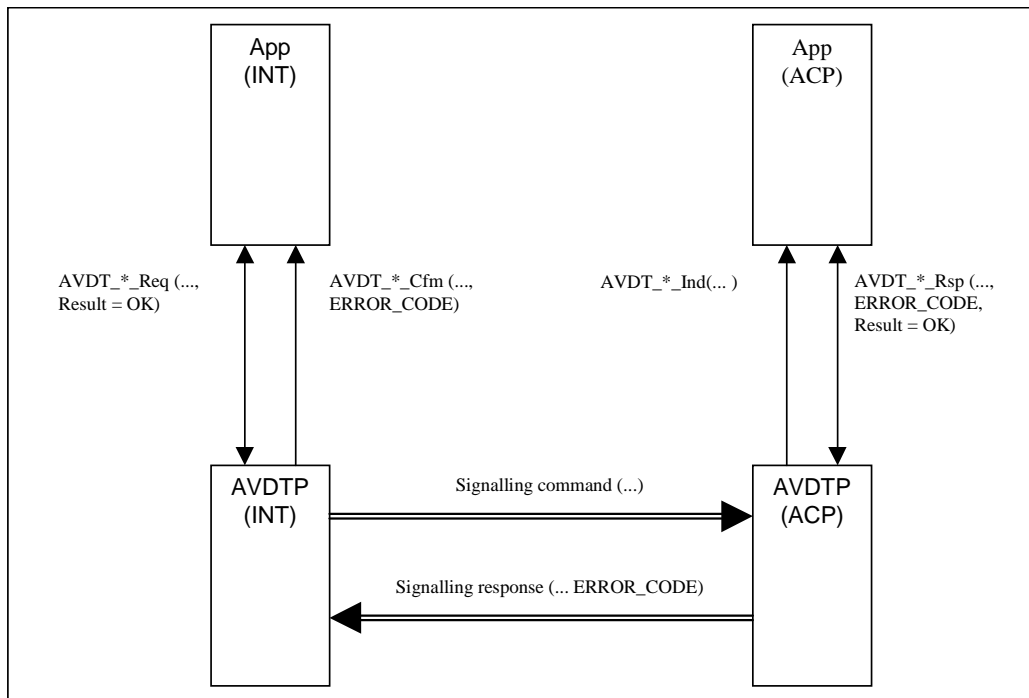

Figure 8.40: ACP Application rejects an INT command

- ACP/AVDTP rejects an INT command signal

A received command signal cannot be interpreted by ACP/AVDTP entity (e.g. contains invalid format information like an out-of-range signal identifier). ACP/AVDTP does not

generate an AVDT_*_Ind event to inform its local application but generates a reject response to the INT device. The ERROR_CODE field contains the reason of rejection.

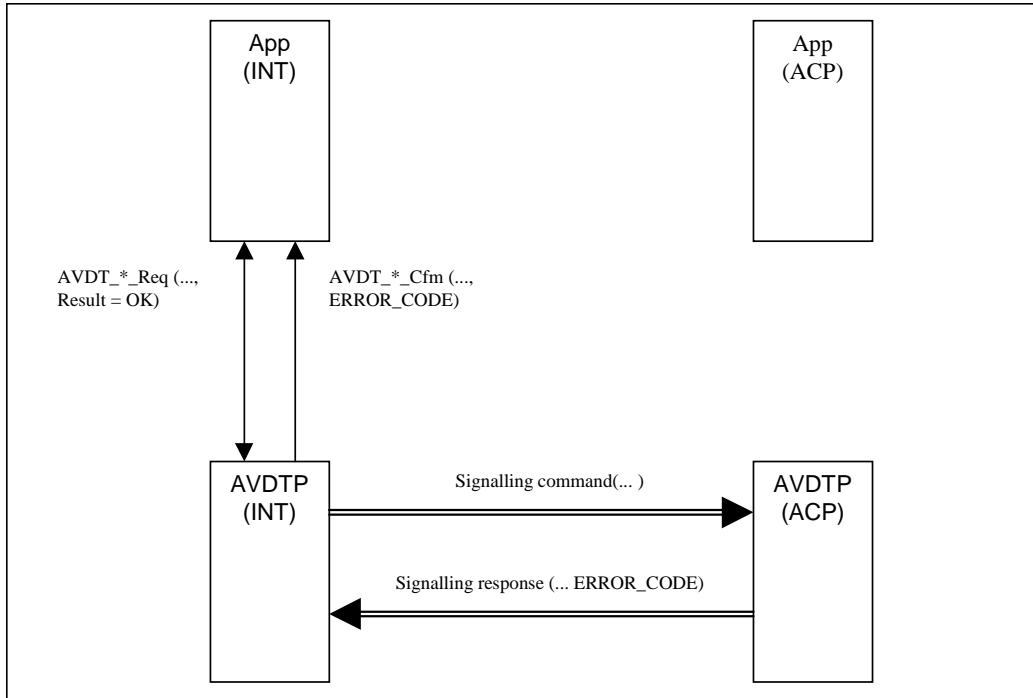

Figure 8.41: ACP/AVDTP rejects an INT command

8.18.6.2 ERROR_CODE tables

ACP to INT, Signal Response Header Error Codes			
Error ID	Related Signaling command	Error Abbreviation	Error Description
0x01	All messages	BAD_HEADER_FORMAT	The request packet header format error that is not specified above ERROR_CODE

ACP to INT, Signal Response Payload Format Error Codes			
Error ID	Related Signaling command	Error Abbreviation	Error Description
0x11	All messages	BAD_LENGTH	The request packet length is not match the assumed length.
0x12	All messages	BAD_ACP_SEID	The requested command indicates an invalid ACP SEID (not addressable)
0x13	Set Configuration	SEP_IN_USE	The SEP is in use
0x14	Reconfigure	SEP_NOT_IN_USE	The SEP is not in use
0x17	Set Configuration Reconfigure	BAD_SERV_CATEGORY	The value of Service Category in the request packet is not defined in AVDTP.
0x18	All messages	BAD_PAYLOAD_FORMAT	The requested command has an incorrect payload format (Format errors not specified in this ERROR_CODE)
0x19	All messages	NOT_SUPPORTED_COMMAND	The requested command is not supported by the device
0x1A	Reconfigure	INVALID_CAPABILITIES	The reconfigure command is an attempt to reconfigure a transport service capabilities of the SEP. Reconfigure is only permitted for application service capabilities

ACP to INT, Signal Response Transport Service Capabilities Error Codes			
Error ID	Related Signaling command	Error Abbreviation	Error Description
0x22	Set Configuration	BAD_RECOVERY_TYPE	The requested Recovery Type is not defined in AVDTP.
0x23	Set Configuration	BAD_MEDIA_TRANSPORT_FORMAT	The format of Media Transport Capability is not correct.
0x25	Set Configuration	BAD_RECOVERY_FORMAT	The format of Recovery Service Capability is not correct.
0x26	Set Configuration	BAD_ROHC_FORMAT	The format of Header Compression Service Capability is not correct.
0x27	Set Configuration	BAD_CP_FORMAT	The format of Content Protection Service Capability is not correct.
0x28	Set Configuration	BAD_MULTIPLEXING_FORMAT	The format of Multiplexing Service Capability is not correct.

0x29	Set Configuration	UNSUPPORTED_CONFIGURAION	Configuration not supported.
------	-------------------	--------------------------	------------------------------

ACP to INT, Procedure Error Codes			
Error ID	Related Signaling command	Error Abbreviation	Error Description
0x31	All messages	BAD_STATE	Indicates that the ACP state machine is in an invalid state in order to process the signal. This also includes the situation when an INT receives a request for the same command that it is currently expecting a response for, see 9.11.

In case the format of the Reporting Service Capability is not correct, the BAD_LENGTH or BAD_PAYLOAD_FORMAT error code **shall** be used.

8.18.6.3 Service Call local errors

During the course of AVDTP services a number of errors not transmitted over the air **can** occur. Those errors are related to invalid service parameters or other local conditions in INT or ACP application service calls. When such errors are detected, they are not reported to the application by means of ERROR_CODE. Instead, an unsuccessful result value is returned to the calling application as an output parameter of the application service call.

It is up to the ACP application to cope with this situation and it is implementation dependent: the ACP application could decide to change the parameter and to retry to use the ABORT procedure (if the possibly addressed SEID is not IDLE).

- **Bad parameter in INT/AVDTP service call**

The INT application wants to request a service and makes an AVDTP service call using bad parameter values. INT/AVDTP does not initiate a signaling transaction but returns an output parameter to the local application with the reason of refusal.

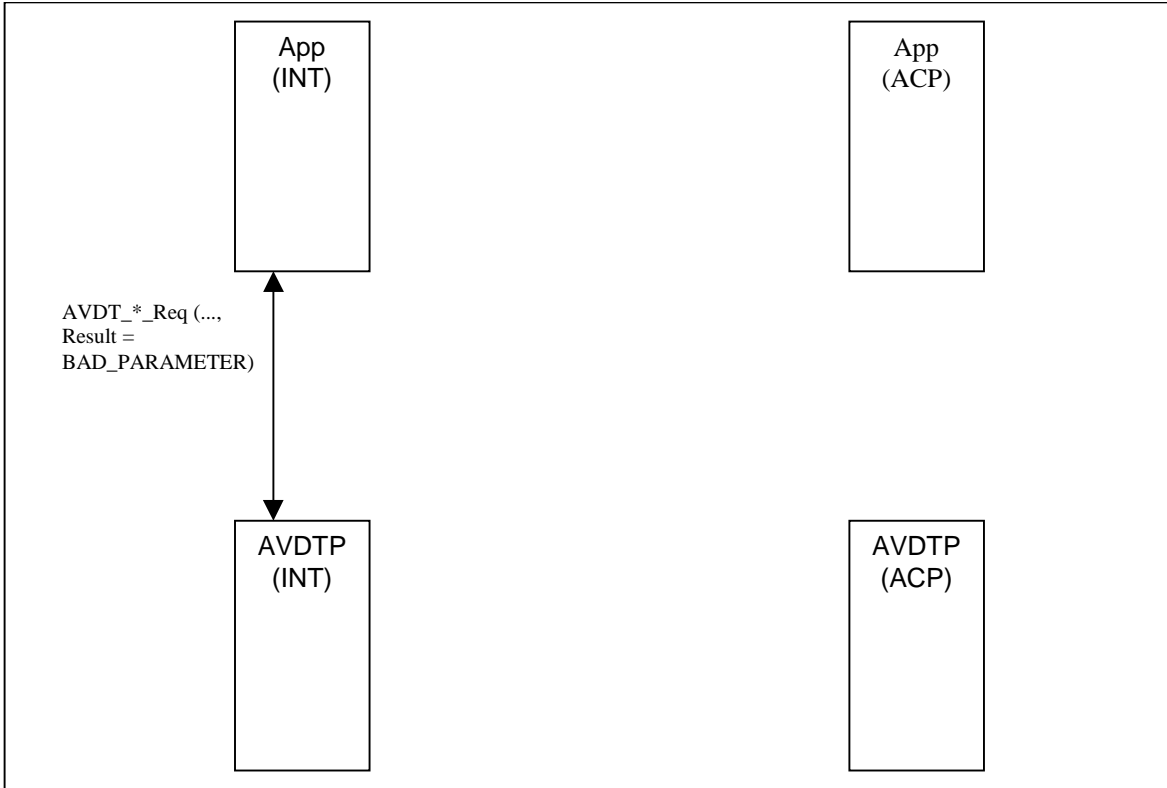

Figure 8.42: BAD parameter in INT/AVDTP service call

- BAD parameter in ACP/AVDTP service call

The ACP application makes an AVDTP service call using bad parameter values in response to a previous AVDT_*_Ind event. ACP/AVDTP does not generate a signaling message but returns an output parameter to the local application with the reason of refusal.

It is up to the ACP application to cope with this situation and it is implementation dependent: the ACP application could decide to change the parameter and to retry, to let the transaction timer to expire or to use the ABORT procedure (if the addressed SEID is not IDLE).

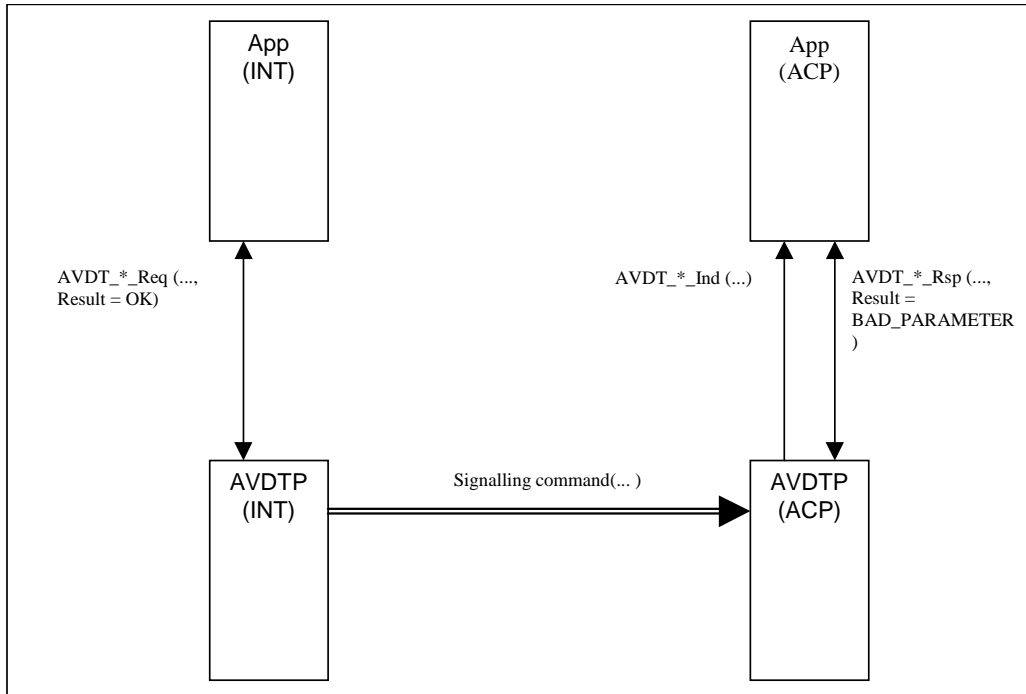

Figure 8.43: Bad parameter in ACP/AVDTP service call

8.19 Service Capabilities

The Service Capability values indicate possible services that **can** be provided by each stream end-point.

Service Capabilities are used in:

- AVDTP_GET_CAPABILITIES_RSP see § 8.7.2
- AVDTP_SET_CONFIGURATION_CMD see § 8.8.1
- AVDTP_GET_CONFIGURATION_RSP see § 8.9.2
- AVDTP_RECONFIGURE_CMD see § 8.10.1

8.19.1 Generic Service Capabilities information elements

The Service Capabilities are categorized. Figure 8.44 shows the generic Service Capabilities field format, which consists of service category, field length and service capabilities. The service category is the first octet. This is because, if user does not

need the service capabilities belonging specific service category, user **can** skip the information by checking the first octet only.

There may be several service capabilities in the payload of the 'Get_Capabilities_Response', 'Get_Configuration_Response' and 'Set_Configuration_Command' signals. However, there may be at most one service capabilities information element per category in the payload. Only for Content Protection, multiple information elements may appear in the 'Get_capabilities response'. As a rule, combinations of capabilities settings that could cause ambiguous or undefined configurations of the addressed SEP **shall** not be used in a 'Set_configuration command'.

The Service Capabilities can appear in any order. The presence of a Service Capability indicates that the Service can be used and hence configured.

7	6	5	4	3	2	1	0	Octet
Service Category, see § Table 8.4								:
Length Of Service Capabilities (LOSC), see § 8.18.2								
Service Capabilities Information Elements, see § 8.19								

Figure 8.44: Generic Service Capabilities field format

The service category is indicated in the top of Service Capabilities field by using following values.

Bits								
7	6	5	4	3	2	1	0	
0	0	0	0	0	0	0	1	Media Transport
0	0	0	0	0	0	1	0	Reporting
0	0	0	0	0	0	1	1	Recovery
0	0	0	0	0	1	0	0	Content Protection
0	0	0	0	0	1	0	1	Header Compression
0	0	0	0	0	1	1	0	Multiplexing
0	0	0	0	0	1	1	1	Media Codec
Other values								RFD

Table 8.4: Service Category information element field values

8.19.2 Media Transport Capabilities

Media Transport Capabilities are based on RFC1889 [3], and some specific fields are defined. Media transport for Video and Audio Service Category shall use the following Service Capability values.

7	6	5	4	3	2	1	0	Octet
Service Category = Media Transport								0
Length Of Service Capability (LOSC) = 0x00, see § 8.18.2								1

Figure 8.45: Service Capabilities field for Media Transport

8.19.3 Reporting Capabilities

Reporting Capabilities value has the following format.

7	6	5	4	3	2	1	0	Octet
Service Category = Reporting								0
Length Of Service Capability (LOSC) = 0x00, see § 8.18.2								1

Figure 8.46: Service Capabilities for Reporting

8.19.4 Recovery Capabilities

An ACP device that supports the Recovery service **shall** expose the following transport capabilities:

7	6	5	4	3	2	1	0	Octet
Service Category = Recovery								0
Length Of Service Capability (LOSC) = 0x03, see § 8.18.2								1
Recovery Type								2
MRWS - Maximum Recovery Window Size								3
MNMP - Maximum Number of Media Packets in Parity Code								4

Figure 8.47: Service Capabilities for Recovery

Information Element	Description	Length	Possible Values
Recovery Type	This information element indicates the recovery type used.	1 Octet	0x00 = Forbidden 0x01 = RFC2733 RFD
MRWS	Maximum Recovery Window Size for a Transport Packet.	1 Octet	0x00 = Forbidden 0x01 to 0x18
MNMP	The maximum number of media packets a specific parity code covers.	1 Octet	0x00 = Forbidden 0x01 to 0x18

Figure 8.48: Recovery Service Capabilities, Information Elements

The INT **shall** set the actual **Maximum Recovery Window Size** and **Maximum Number of Media Packets in Parity Code** for the session through the AVDTP_SET_CONFIGURATION command, see § 8.8.

8.19.5 Media Codec Capabilities

Media Codec Capabilities of a SEP have the following format. The Media Type and Media Codec Type fields, are defined in the Bluetooth Assigned Numbers document, see [6]. The Media Codec Specific Information Elements are defined in the relevant AV Application Profile.

7	6	5	4	3	2	1	0	Octet
Service Category = Media Codec Capabilities								0
Length Of Service Capability (LOSC) see § 8.18.2								1
Media Type				RFA				2
Media Codec Type								3
Media Codec Specific Information Elements								:

Figure 8.49: Service Capabilities field for Media Codecs

8.19.6 Content Protection Capabilities

When the ACP device has a content protection capability, the content protection type information that the stream supports is indicated in the Content Protection Capabilities. These capabilities can also include a content protection type dependent field.

7	6	5	4	3	2	1	0	Octet
Service Category = Content Protection								0
Length Of Service Capabilities (LOSC) see § 8.18.2								1
CP_TYPE_LSB								2
CP_TYPE_MSB								3
CP_Type Specific Value								:

Figure 8.50: Service Capabilities for Content Protection

CP_TYPE_MSB and CP_TYPE_LSB are resp. the MSB and LSB part of a single information element, the Content Protection Type, CP_TYPE, which is defined by Bluetooth Assigned Numbers see [6] . For details about CP_TYPE and CP_Type Specific Value refer to APPENDIX C – Content Protection Procedure

8.19.7 Header Compression Capabilities

Header Compression Capabilities values, are defined as shown in Figure 8.51. When used in the Set Configuration command, it informs the INT if the service is available for a certain type of stream (Media Packets, Recovery Packets). It also informs the INT about the possibility of the ACP to support a back channel.

When used in the Set/Get Configuration and Reconfigure commands the bits indicate if Header Compression Service shall be supported and shall be used for this session.

7	6	5	4	3	2	1	0	Octet
Service Category = Header Compression Capabilities								0
Length Of Service Capabilities (LOSC) = 0x01 see § 8.18.2								1
BackCh	Media	Recovery	RFA					2

Figure 8.51: Service Capabilities for Header Compression message format

Information Element	Description	Length	Possible Values
Media	In a Get Capabilities response, this shall inform the INT if the Header Compression Service is available for Basic Service. In all other commands it indicates if the service shall be used/is used	1	0=Not Available/Not Used 1=Available/In Use
Recovery	In a Get Capabilities response, this shall inform the INT if the Header Compression Service is available for Recovery Service. In all other commands it indicates if the service shall be used/is used	1	0=Not Available/Not Used 1=Available/In Use
BackCh	In a Get Capabilities response, this shall inform the INT if the Header Compression Service supports a back channel. (In certain multi channel and broadcast scenarios it may not be supported.) In all other commands it indicates if the back channel shall be used/is used	1	0=Not Available/Not Used 1=Available/In Use

Figure 8.52: Header Compression Service Capabilities, Information Elements

8.19.8 Multiplexing Capabilities

If the ACP supports Multiplexing Service, it includes a Service Capability field as defined in Table 8.5 in the GET_CAPABILITIES_RSP to the INT. The INT, if also supporting Multiplexing Service and agreeing to use it, uses an entry of the same format in the SET_CONFIGURATION_CMD, where it **may** have altered the parameter settings.

7	6	5	4	3	2	1	0	Octet
Service Category = Multiplexing Mode								0
Length Of Service Capabilities (LOSC), see 8.18.2								1
FRAG	RFA							2
TSID (media transport session)				RFA				3
TCID				RFA				4
TSID (reporting transport session)				RFA				5
TCID				RFA				6
TSID (recovery transport session)				RFA				7
TCID				RFA				8

Table 8.5: Service Capabilities for Multiplexing

Information Element	Description	Length	Possible Values
FRAG	Allow Adaptation Layer Fragmentation (see section 7.5.3)	1 bit	0 = don't allow fragmentation, 1 = allow fragmentation
RFA		7 bits	
TSID	Request/indicate value of the Transport Session Identifier for a media, reporting, or recovery transport sessions, respectively. See for definition sec. 4.13 and for usage in Multiplexed sec. 7.5.2	5 bits	0x00 = Used for TSID query 0x01 to 0x1E valid TSID values 0x1F = RFD
TCID	Request/indicate value for TCID for a media, reporting, or transport session. See definition in sec. 4.15	5 bit	0x00 = Used for TCID query 0x01 to 0x1E valid TCID values 0x1F = RFD

Depending on the service configuration, the Service Capability entry **can** comprise between 4 and 9 octets (including Service Category field).

The use of one, two, or three entries for the different transport sessions **shall** be consistent with the capability exposure or configuration of the Reporting and Recovery service. The first entry for the media transport **shall** be always present. If Reporting Service is exposed or configured, the corresponding entry appears next. If Recovery Service is exposed or configured, the corresponding entry **shall** appear next (i.e. last).

The TSID and TCID information **can** be conveyed in both the GET_CAPABILITIES_RSP and the SET_CONFIGURATION_CMD. If used in the GET_CAPABILITIES_RSP, the ACP **may** suggest settings for TSID, and/or TCID. The INT **may** override this suggestion by using different settings in the SET_CONFIGURATION_CMD. Alternatively; the ACP **may** use the value of 0x00 for any of the TSID/TCID fields to query the values from the INT.

Note that if Multiplexing Service is not exposed, this service capability entry is not used, and transport session **shall** be used (on individual transport channels each) without explicit TSID exchange on the air interface. In addition, TSID and TCID are connection-local identifiers. Therefore, as long as the context information in both devices is consistent, both AVDTP entities **shall** control which values are free or in use.

9 State Diagrams

The following sections define the INT and ACP states machines, which includes state definitions and state transitions diagrams.

9.1 State Definitions

State	State Name	Description
I00	AVDTP_IDLE	State machine has been initialized
I01	AVDTP_CONFIGURED	INT has successfully configured an ACP's stream end-point.
I02	AVDTP_OPEN	INT and ACP have successfully opened a stream end-point.
I03	AVDTP_STREAMING	INT and ACP have successfully established a streaming session on a stream end-point.
I04	AVDTP_CLOSING	INT and ACP are closing a stream end-point.
I05	AVDTP_ABORTING	INT or ACP has requested to abort the stream establishment.

Table 9.1: AVDTP State Definitions

The following sections provide State Transitions Diagrams (STD) for the SEP state machine.

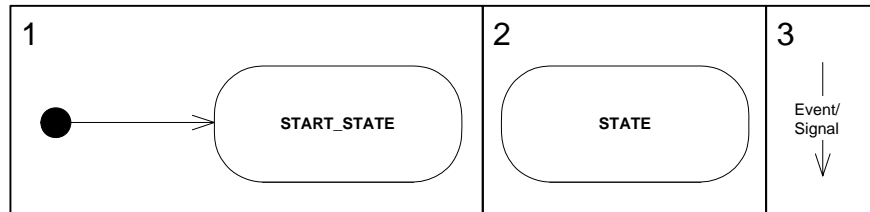

Figure 9.1: State Transition Diagram, Symbol Conventions

1. Indicates the Initial starting state for the STD
2. Indicates a state
3. Shows a State Transition. **Event** indicates, for instance, receive or send of a signal. **Signal** indicates the signal that is received or sent.

9.2 Collect Capabilities

Collect Capabilities, which includes Discover and Get Capabilities, procedures **can** be performed in any state.

9.3 Stream Configuration

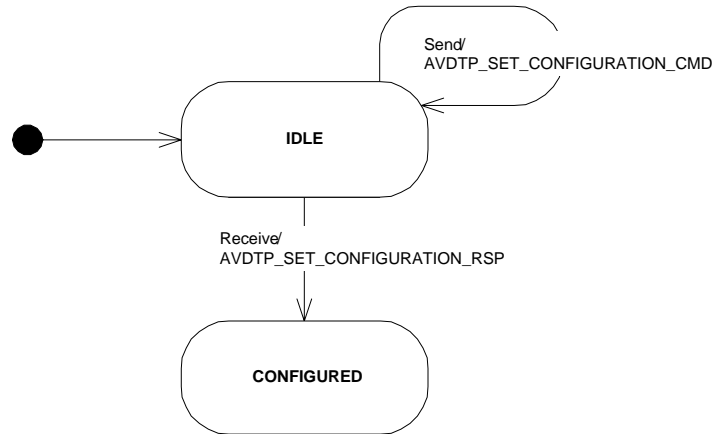

Figure 9.2: INT – Stream Configuration State Transition Diagram

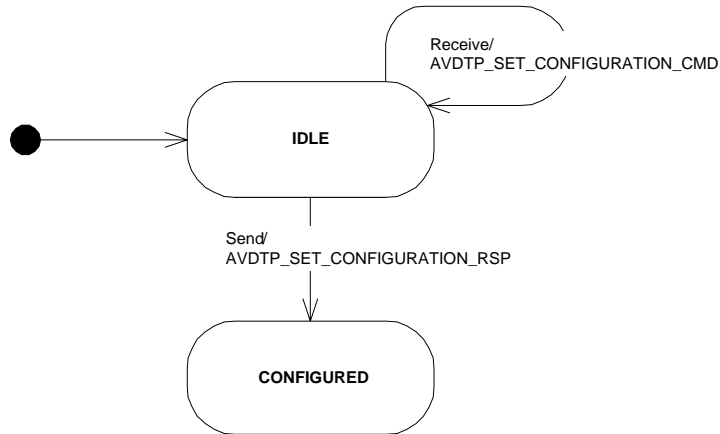

Figure 9.3: ACP – Stream Configuration State Transition Diagram

9.4 Connection Establishment

Figure 9.4, shows the state transition diagram for INT when moving from CONFIGURED to OPEN state. The INT sends an AVDTP_OPEN_CMD; there is no state change for the SEP.

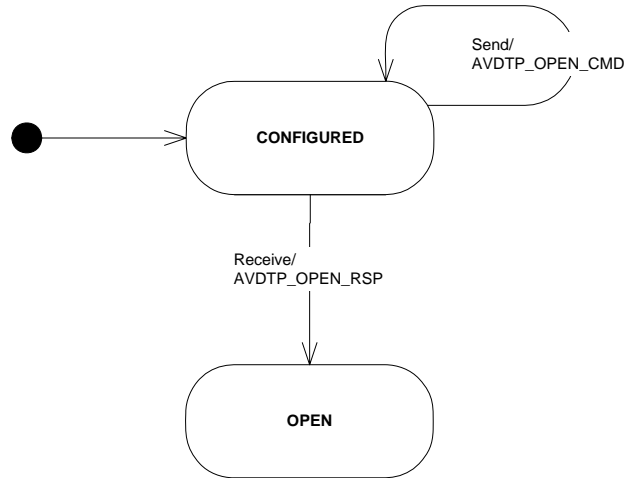

Figure 9.4: INT – Connection Establishment State Transition Diagram

When the ACP receives the AVDTP_OPEN_CMD, an indication is sent to the Upper Layer. The ACP Upper Layer deals with the indication and sends a response back to AVDTP. If all was successful, the ACP-SEP state changes to OPEN.

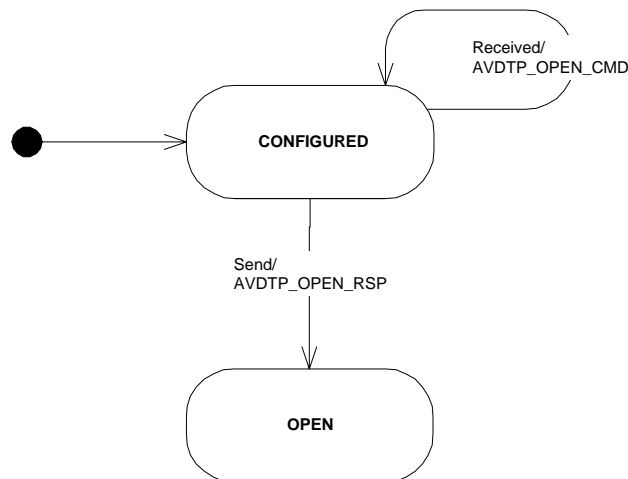

Figure 9.5: ACP – Connection Establishment State Transition Diagram

Upon receiving AVDTP_OPEN_RSP, the INT establishes the Transport Sessions (L2CAP channels). If all the Transport Sessions were successfully established the INT-SEP state progresses to OPEN and a confirmation is sent to the INT's Upper Layer.

9.5 Start Streaming

9.5.1 INT is a SNK Device

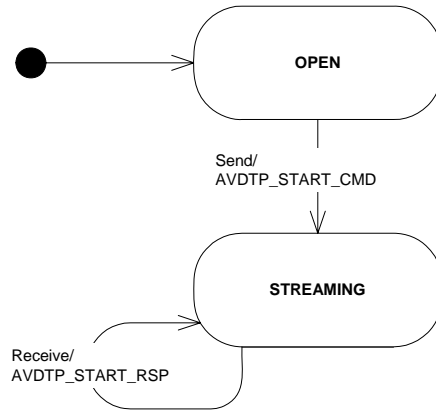

Figure 9.6: INT – Start Streaming State Transition Diagram

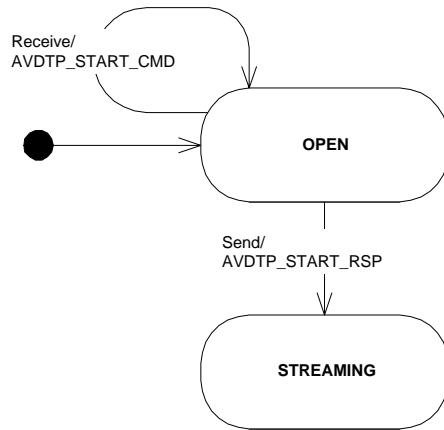

Figure 9.7: ACP – Start Streaming State Transition Diagram

9.5.2 INT is a SRC Device

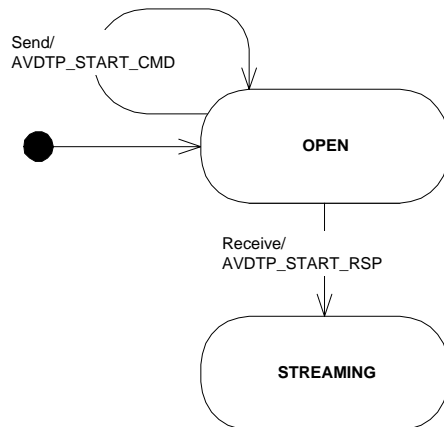

Figure 9.8: INT – Start Streaming State Transition Diagram

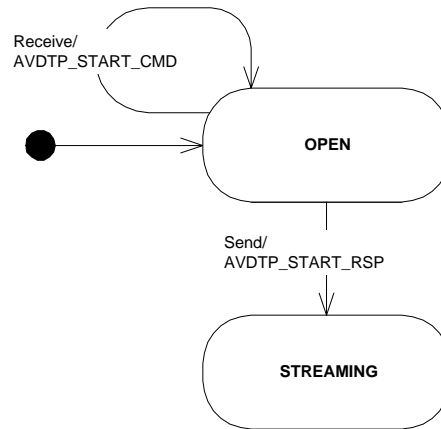

Figure 9.9: ACP – Start Streaming State Transition Diagram

9.6 Connection Release - Open/Streaming

Connection Release **can** be initiated in Open or Streaming state. When a device participating within an AVDTP stream sends an AVDTP_CLOSE_CMD, it becomes the INT of the Connection Release procedure. The following sections describe the state transitions from INT and ACP point of view.

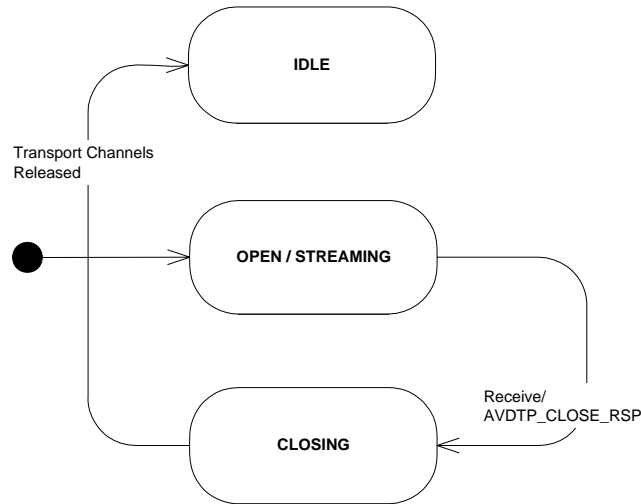

Figure 9.10: INT - Connection Release State Transition Diagram

With reference to Figure 9.10, the INT is in state OPEN or STREAMING, and receives a request from the Upper Layer to release a specific SEP. AVDTP sends an AVTDP_CLOSE_CMD to what has now become the ACP.

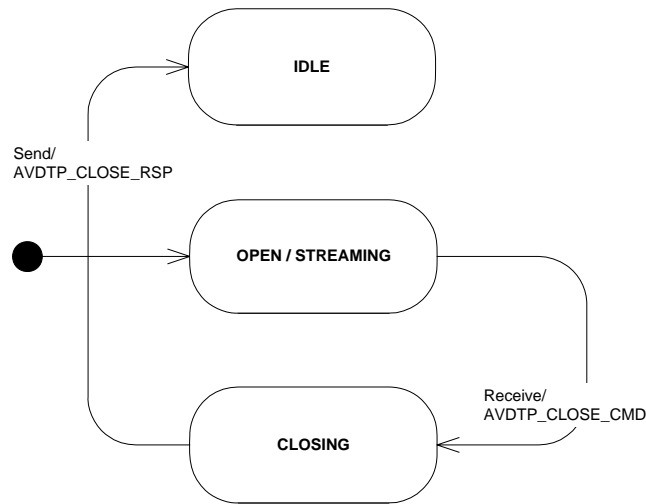

Figure 9.11: ACP - Connection Release State Transition Diagram

When the ACP receives the AVDTP_CLOSE_CMD, see Figure 9.11, the state of the SEP changes from OPEN/STREAMING to CLOSING and, an indication is sent to the Upper Layer. When the Upper Layer has completed releasing all resources allocated to the stream, an AVDTP_CLOSE_RSP is sent back to the INT. When the INT receives the AVDTP_CLOSE_RSP, all the associated Transport Sessions are released. After the Transport Sessions are release a confirmation is sent to the INT Upper Layer and the INT-SEP state changes to IDLE.

9.7 Stream Suspend

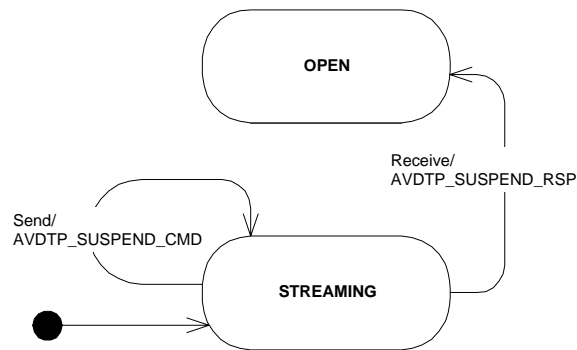

Figure 9.12: INT – Stream Suspend State Transition Diagram

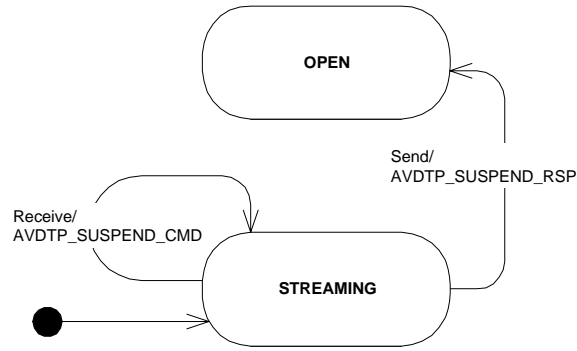

Figure 9.13: ACP – Stream Suspend State Transition Diagram

9.8 Stream Change Parameters

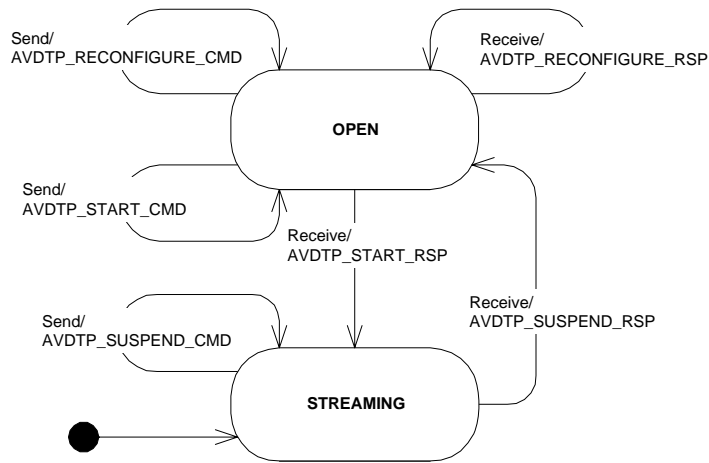

Figure 9.14: INT – Stream Change Parameters State Transition Diagram

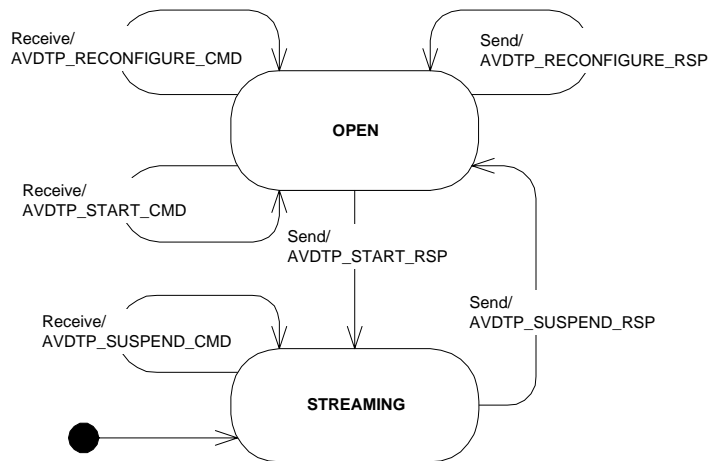

Figure 9.15: ACP – Stream Change Parameters State Transition Diagram

9.9 Abort Stream

Figure 9.16 and Figure 9.17 depict the state transition, from ACP and INT point of views, when the state is CONFIGURED, OPEN, STREAMING or CLOSING. However, AVDTP_ABORT_CMD can be sent or received in IDLE state. In the event that an AVDTP_ABORT_CMD is received in IDLE state, ACP or INT shall reply with an AVDTP_ABORT_RSP, no state change is required. As there should be no Transport Channels established no actions have to be taken to release the Transport Channels.

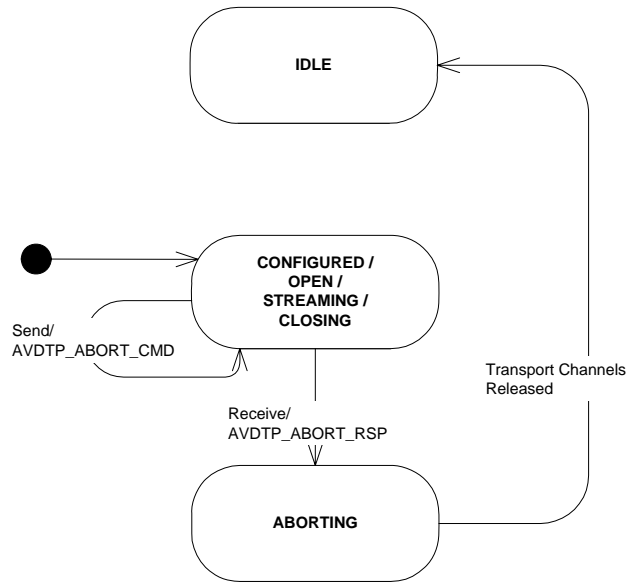

Figure 9.16 : INT - Abort Stream State Transition Diagram

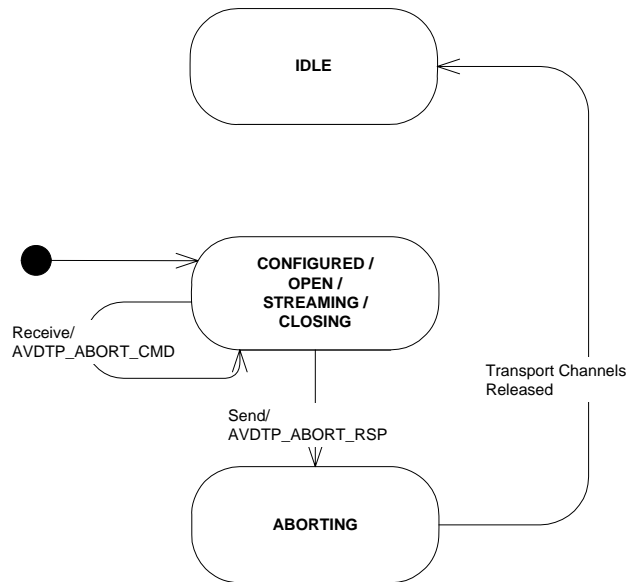

Figure 9.17: ACP - Abort Stream State Transition Diagram

9.10 Content Security

Content Security procedures **can** be performed in any state, except IDLE, CLOSING and ABORTING.

9.11 INT/ACP State Inconsistency

Because AVDTP is typically used on unreliable channels, signaling messages **can** be lost due to an L2CAP Flush Timeout. To avoid inconsistencies between the INT and ACP state machines, either the Abort command or a retransmission of the message **can** be used.

Note: If the L2CAP Retransmission Mode (first defined within Bluetooth core specification v1.2) is supported, implementations may activate it for the AVDTP signaling channel to improve reliability.

In case an INT receives a request for the same command that it is expecting a response for, it **may** reject the command and **may** use a random time offset for a retransmission to avoid deadlock.

10 References

- [1] Bluetooth SIG, Specification of the Bluetooth System, Core, Version 1.2 or Later
- [2] Bluetooth SIG, Specification of the Bluetooth System, Profiles
- [3] IETF RFC3550 / RFC1889 (obsolete) RTP, A Transport Protocol for Real-Time Applications
- [4] IETF RFC2733 – An RTP Payload Format for Generic Forward Error Correction
- [5] IETF RFC3095 – Robust Header Compression (ROHC)
- [6] Bluetooth SIG, Bluetooth Assigned Numbers,
<http://www.bluetooth.org/assigned-numbers.htm>
- [7] IETF RFC2326 – Real Time Streaming Protocol (RTSP)
- [8] IETF RFC2327 – Session Description Protocol (SDP)

11 List of Figures

Figure 1.1: AVDTP and Bluetooth Protocol Stack	10
Figure 2.1: A/V Architecture Block Diagram	12
Figure 5.1: AVDTP Architecture	20
Figure 5.2: Stream End Point Architecture	22
Figure 5.3: AVDTP Basic Service	24
Figure 5.4: AVDTP Recovery Service.....	25
Figure 5.5: AVDTP Reporting Service	26
Figure 5.6: AVDTP Adaptation Service Option	27
Figure 5.7: Transport and Signaling Channel Establishment	28
Figure 6.1: Signaling Channel Establishment Procedure	29
Figure 6.2: Transaction Model of AVDTP Command/Response	29
Figure 6.3: Stream End-point Discovery to Stream Release	31
Figure 6.4 : AVDTP State Machine Overview.....	32
Figure 6.5: Stream End Point Discovery Procedure	33
Figure 6.6: Get Capabilities Procedure.....	33
Figure 6.7: Stream Configuration Procedure	34
Figure 6.8: Stream Get Configuration Procedure	35
Figure 6.9: Stream Establishment Procedure	35
Figure 6.10: Stream Start Procedure, Device A is a Source Device	36
Figure 6.11: Stream Start Procedure, Device A is a Sink Device.....	36
Figure 6.12: Stream Release Procedure	37
Figure 6.13: Stream Suspend Procedure	38
Figure 6.14: Stream Reconfigure Procedure	38
Figure 6.15: Content Security Control Procedure	39
Figure 6.16: Abort Procedure.....	39
Figure 6.17: General Reject Procedure	40
Figure 7.1: Transport Channels for Media Transport.....	41
Figure 7.2: Media Packet Format.....	42
Figure 7.3: Transport Channels for Media Transport and Reporting.....	44
Figure 7.4: SR Reporting packet Format	45
Figure 7.5: SDES reporting packet format	47
Figure 7.6: CNAME - Canonical end-point identifier SDES item	48
Figure 7.7: Transport Channels for Media Transport, Recovery, and Reporting.....	49
Figure 7.8: Adaptation Layer Packet Format	53
Figure 8.1: Example of the Service Capabilities negotiation procedures	56
Figure 8.2: Packet format for signaling message (Single L2CAP packet).....	57
Figure 8.3: Packet format for signaling message (Multi L2CAP packets)	58
Figure 8.4: Signaling message format for single packets	58
Figure 8.5: Signaling message format for start packets	58
Figure 8.6: Signaling message format for continue and end packets.....	58
Figure 8.7: Stream End Point Discovery command message	61
Figure 8.8: Stream End Point Discovery Response message format.....	61
Figure 8.9: Stream End Point Discovery Reject message format.....	61
Figure 8.10: Get Capabilities Command message format.....	62
Figure 8.11: Get Capabilities Response message format	62
Figure 8.12: Stream Get Capabilities Reject message format.....	62
Figure 8.13: Set Configuration Command message format	63
Figure 8.14: Set Configuration Response message format.....	63
Figure 8.15: Set Configuration Reject message format.....	63
Figure 8.16: Get Configuration Command message format.....	64
Figure 8.17: Get Configuration Response message format	64

Figure 8.18: Get Configuration Reject message format 64

Figure 8.19: Reconfigure Command message format 65

Figure 8.20: Reconfigure Response message format 65

Figure 8.21: Reconfigure Reject message format 65

Figure 8.22: Open Stream Command message format 66

Figure 8.23: Open Stream Response message format 66

Figure 8.24: Open Stream Reject message format 66

Figure 8.25: Start Stream Command message format 67

Figure 8.26: Start Stream Response message format 67

Figure 8.27: Start Stream Reject message format 67

Figure 8.28: Close Stream Command message format 68

Figure 8.29: Close Stream Response message format 68

Figure 8.30: Close Stream Reject message format 68

Figure 8.31: Suspend Command message format 69

Figure 8.32: Suspend Response message format 69

Figure 8.33: Suspend Reject message format 69

Figure 8.34: Abort Command message format 70

Figure 8.35: Abort Response message format 70

Figure 8.36: Security Control command message format 70

Figure 8.37: Security Control response message format 71

Figure 8.38: Security Control Reject message format 71

Figure 8.39: General Reject response format 71

Figure 8.40: ACP Application rejects an INT command 73

Figure 8.41: ACP/AVDTP rejects an INT command 74

Figure 8.42: BAD parameter in INT/AVDTP service call 77

Figure 8.43: Bad parameter in ACP/AVDTP service call 78

Figure 8.44: Generic Service Capabilities field format 79

Figure 8.45: Service Capabilities field for Media Transport 80

Figure 8.46: Service Capabilities for Reporting 80

Figure 8.47: Service Capabilities for Recovery 80

Figure 8.48: Recovery Service Capabilities, Information Elements 80

Figure 8.49: Service Capabilities field for Media Codecs 81

Figure 8.50: Service Capabilities for Content Protection 81

Figure 8.51: Service Capabilities for Header Compression message format 82

Figure 8.52: Header Compression Service Capabilities, Information Elements 82

Figure 9.1: State Transition Diagram, Symbol Conventions 85

Figure 9.2: INT – Stream Configuration State Transition Diagram 86

Figure 9.3: ACP – Stream Configuration State Transition Diagram 86

Figure 9.4: INT – Connection Establishment State Transition Diagram 87

Figure 9.5: ACP – Connection Establishment State Transition Diagram 87

Figure 9.6: INT – Start Streaming State Transition Diagram 88

Figure 9.7: ACP – Start Streaming State Transition Diagram 88

Figure 9.8: INT – Start Streaming State Transition Diagram 89

Figure 9.9: ACP – Start Streaming State Transition Diagram 89

Figure 9.10: INT - Connection Release State Transition Diagram 89

Figure 9.11: ACP - Connection Release State Transition Diagram 90

Figure 9.12: INT – Stream Suspend State Transition Diagram 90

Figure 9.13: ACP – Stream Suspend State Transition Diagram 91

Figure 9.14: INT – Stream Change Parameters State Transition Diagram 91

Figure 9.15: ACP – Stream Change Parameters State Transition Diagram 91

Figure 9.16 : INT - Abort Stream State Transition Diagram 92

Figure 9.17: ACP - Abort Stream State Transition Diagram 92

Figure 15.1: Example of Service Parameter message format 125

Figure 15.2: Content Security Control Procedure 125

Figure 15.3: Example of Service Parameter message format 125

12 List of Tables

Table 2.1: A/V Architectural Functionality	13
Table 2.2: A/V Architectural Interfaces	13
Table 7.1: Media Packet Information Elements (taken from [3]).....	43
Table 7.2: Reporting Packets Information Elements (taken from [3]).....	47
Table 7.3: SDES Reporting Packets Information Elements (taken from [3])	47
Table 7.4: Adaptation Layer Header Information Elements.....	54
Table 8.1: Packet Type field values	59
Table 8.2: Message Type field values	59
Table 8.3: Signal Identifier field values	60
Table 8.4: Service Category information element field values.....	79
Table 8.5: Service Capabilities for Multiplexing	83
Table 9.1: AVDTP State Definitions	85

13 APPENDIX A – AVDTP Upper Interface

This section presents an abstract description of the services offered by AVDTP in terms of service primitives and parameters. The service interfaces are specified for testing purposes only, and **may** be used as a basis for other application specific implementations. The interface is described independently of any platform specific implementation.

13.1 Signaling Interface

The AVDTP signaling part provides two types of service interfaces:

- Event registration service call: an application **can** perform registration for being notified when some asynchronous events are detected by AVDTP. At registration time, the application **shall** indicate what events **shall** be reported; the application also provides an entry point where it **can** be called back in case such events occur. Additional input and output parameters **can** be required at registration time for appropriate service configuration. The callback entry point is specified with all the input parameters that **shall** be notified by the service at the time the event is signaled.
- Application direct calls for service: this interface allows an application to request the execution of a particular on-demand service. A direct service call is made through a unique entry point; it requires a number of input parameters and a number of output parameters to be exchanged at execution time. An example of such direct call is the request of a compliant device to send a control message to the peer device.

In this section, bracketed parameters are optional or conditional parameters that depend on the service context: for instance in the case of reject responses some parameters are not relevant, as they are not transferred back to the requesting side.

When parameter types, values or ranges are not specified the AVDTP signaling section **shall** be used as reference.

13.1.1 Event Registration service call

Service	Input Parameters	Output Parameters
AVDT_Sig_Event_Registration	Event, Callback	Result

Description:

The aim of this primitive is to request an application callback when the selected indication Event occurs.

Input Parameters:

<i>Event</i>	<i>Type: uint</i>	<i>Size: 2 octets</i>
Value	Description	
0x0000	Forbidden	
0x0001	AVDT_ConnectReq_Ind	
0x0002	AVDT_ConnectReq_Cfm	
0x0003	AVDT_DisconnectReq_Ind	
0x0004	AVDT_DisconnectReq_Cfm	
0x0005	AVDT_Discover_Ind	
0x0006	AVDT_Discover_Cfm	
0x0007	AVDT_Get_Capabilities_Ind	
0x0008	AVDT_Get_Capabilities_Cfm	
0x0009	AVDT_Set_Configuration_Ind	
0x000A	AVDT_Set_Configuration_Cfm	
0x000B	AVDT_Get_Configuration_Ind	
0x000C	AVDT_Get_Configuration_Cfm	
0x000D	AVDT_Open_Ind	
0x000E	AVDT_Open_Cfm	
0x000F	AVDT_Close_Ind	
0x0010	AVDT_Close_Cfm	
0x0011	AVDT_Start_Ind	
0x0012	AVDT_Start_Cfm	
0x0013	AVDT_Suspend_Ind	
0x0014	AVDT_Suspend_Cfm	
0x0015	AVDT_ReConfigure_Ind	
0x0016	AVDT_ReConfigure_Cfm	
0x0017	AVDT_Security_Control_Ind	
0x0018	AVDT_Security_Control_Cfm	
0x0019	AVDT_Abort_Ind	
0x001A	AVDT_Abort_Cfm	
Other	RFD	

Event definitions:

- AVDT_ConnectReq_Ind: This event is sent by an AVDTP entity to the local application when the remote side makes a connection attempt and no signaling channel has been setup between both entities.
- AVDT_ConnectReq_Cfm: This event is sent by an AVDTP entity to the local application when a request to connect the local AVDTP entity to the peer entity is complete.

- AVDT_DisconnectReq_Ind: This event is sent by an AVDTP entity to the local application when the signaling channel between peer AVDTP entities becomes unavailable
- AVDT_DisconnectReq_Cfm: This event is sent by an AVDTP entity to the local application when a request to disconnect the local AVDTP entity to the peer entity is complete.
- AVDT_Discover_Ind: This event is sent by an AVDTP entity to the local application to signal the reception of an AVDTP_DISCOVER signal command from a peer entity.
- AVDT_Discover_Cfm: This event is sent by an AVDTP entity to the local application, to signal the completion of a **Stream discover** procedure, initiated by the local entity.
- AVDT_Get_Capabilities_Ind: This event is sent by an AVDTP entity to the local application to signal the reception of an AVDTP_GET_CAPABILITIES signal command from a peer entity.
- AVDT_Get_Capabilities_Cfm: This event is sent by an AVDTP entity to the local application to signal the completion of a **Stream Get Capabilities** procedure initiated by the local entity.
- AVDT_Set_Configuration_Ind: This event is sent by an AVDTP entity to the local application to signal the reception of an AVDTP_SET_CONFIGURATION signal command from a peer entity.
- AVDT_Set_Configuration_Cfm: This event is sent by an AVDTP entity to the local application to signal the completion of a **Stream Set Configuration** procedure initiated by the local entity.
- AVDT_Get_Configuration_Ind: This event is sent by an AVDTP entity to the local application to signal the reception of an AVDTP_GET_CONFIGURATION signal command from a peer entity.
- AVDT_Get_Configuration_Cfm: This event is sent by an AVDTP entity to the local application to signal the completion of a **Stream Get Configuration** procedure initiated by the local entity.
- AVDT_Open_Ind: This event is sent by an AVDTP entity to the local application to signal the reception of an AVDTP_OPEN signal command from a peer entity.
- AVDT_Open_Cfm: This event is sent by an AVDTP entity to the local application to signal the completion of an **Open Stream** procedure initiated by the local entity.
- AVDT_Close_Ind: This event is sent by an AVDTP entity to the local application to signal the reception of an AVDTP_CLOSE signal command from a peer entity.
- AVDT_Close_Cfm: This event is sent by an AVDTP entity to the local application to signal the completion of a **Close Stream** procedure initiated by the local entity.

- AVDT_Start_Ind: This event is sent by an AVDTP entity to the local application to signal the reception of an AVDTP_START signal command from a peer entity.
- AVDT_Start_Cfm: This event is sent by an AVDTP entity to the local application to signal the completion of a **Start Stream** procedure initiated by the local entity.
- AVDT_Suspend_Ind: This event is sent by an AVDTP entity to the local application to signal the reception of an AVDTP_SUSPEND signal command from a peer entity.
- AVDT_Suspend_Cfm: This event is sent by an AVDTP entity to the local application to signal the completion of a **Suspend** procedure initiated by the local entity.
- AVDT_ReConfigure_Ind: This event is sent by an AVDTP entity to the local application to signal the reception of an AVDTP_RECONFIGURE signal command from a peer entity.
- AVDT_ReConfigure_Cfm: This event is sent by an AVDTP entity to the local application to signal the completion of a **Reconfigure** procedure initiated by the local entity.
- AVDT_Security_Control_Ind: This event is sent by an AVDTP entity to the local application to signal the reception of an AVDTP_SECURITY_CONTROL signal command from a peer entity.
- AVDT_Security_Control_Cfm: This event is sent by an AVDTP entity to the local application to signal the completion of a **Security Control** procedure initiated by the local entity.
- AVDT_Abort_Ind: This event is sent by an AVDTP entity to the local application to signal the reception of an AVDTP_ABORT signal command from a peer entity.
- AVDT_Abort_Cfm: This event is sent by an AVDTP entity to the local application to signal the completion of an **Abort** procedure initiated by the local entity.

Audio/Video Distribution Transport Protocol (AVDTP)

<i>Callback</i>	<i>Type: function</i>	<i>Size: N/A</i>
Event	Callback Function Input Parameters	
AVDT_ConnectReq_Ind	BD_ADDR	
AVDT_ConnectReq_Cfm	BD_ADDR, Connect Result, Config Result, Status	
AVDT_DisconnectReq_Ind	BD_ADDR	
AVDT_DisconnectReq_Cfm	BD_ADDR, Disconnect Result	
AVDT_Discover_Ind	Transaction, BD_ADDR	
AVDT_Discover_Cfm	Transaction, [List of ACP SEIDs primary data], [Error Code]	
AVDT_Get_Capabilities_Ind	Transaction, BD_ADDR, ACP SEID	
AVDT_Get_Capabilities_Cfm	Transaction, List of Stream Capabilities, [Error Code]	
AVDT_Set_Configuration_Ind	Transaction, BD_ADDR, ACP SEID, INT SEID, Stream Handle, List of Configuration Parameters	
AVDT_Set_Configuration_Cfm	Transaction, [First Stream Configuration Category to Fail], [Error Code]	
AVDT_Get_Configuration_Ind	Transaction, Stream Handle	
AVDT_Get_Configuration_Cfm	Transaction, Stream Handle, List of Stream Configuration parameters, [Error Code]	
AVDT_Open_Ind	Transaction, Stream Handle	
AVDT_Open_Cfm	Transaction, [Error Code]	
AVDT_Close_Ind	Transaction, Stream Handle	
AVDT_Close_Cfm	Transaction, [Error Code]	
AVDT_Start_Ind	Transaction, List of Stream Handles	
AVDT_Start_Cfm	Transaction, [Stream Handle], [Error Code]	
AVDT_Suspend_Ind	Transaction, List of Stream Handles	
AVDT_Suspend_Cfm	Transaction, [Stream Handle], [Error Code]	
AVDT_ReConfigure_Ind	Transaction, Stream Handle, List of Reconfigurable Stream Configuration parameters	
AVDT_Reconfigure_Cfm	Transaction, [First Stream Configuration Category to Fail], [Error Code]	
AVDT_Security_Control_Ind	Transaction, Stream Handle, Length of Security Control Data, Security Control Data	
AVDT_Security_Control_Cfm	Transaction, Length of Security Control data, Security Control Data, [Error Code]	
AVDT_Abort_Ind	Transaction, Stream Handle	
AVDT_Abort_Cfm	Transaction, [Error Code]	
Other	RFD	

Output Parameters:

Result *Type: uint* *Size: 2 octets*

Value	Description
0x0000	Event successfully registered
0x0001	Event registration failed

Callback Input Parameters:

BD_ADDR *Type: uint* *Size: 6 octets*

Value	Description
0XXXXXXXXXXXXX	Unique Bluetooth address of the requesting or responding remote device

Connect Result *Type: uint* *Size: 2 octets*

Value	Description
0XXXXX	L2CAP Connect Request Result (See relevant specification)

Config Result *Type: uint* *Size: 2 octets*

Value	Description
0XXXXX	L2CAP Configure Result (See relevant specification)

Status *Type: uint* *Size: 2 octets*

Value	Description
0XXXXX	L2CAP Connect Request Status (See relevant specification)

13.2

Disconnect Result *Type: uint* *Size: 2 octets*

Value	Description
0XXXXX	L2CAP Disconnect Result (See relevant specification)

Transaction *Type: uint* *Size: 1 octet*

Value	Description
0xXX	Identifier of the transaction, which the event relates to

[List of ACP SEIDs primary data] *Type: N/A* *Size: N/A*

Value	Description
N/A	List of available ACP SEID's including the In Use indication, Media Type and SEP type information for each one

[Error Code] *Type: uint* *Size: 1 octet*

Value	Description
0xXX	Error code returned by the remote side

ACP SEID *Type: uint* *Size: 1 octet*

Value	Description
0xXX	ACP assigned identity of the addressed Stream End Point

INT SEID *Type: uint* *Size: 1 octet*

Value	Description
-------	-------------

0xXX	INT assigned identity of the addressed Stream End Point
------	---

List of Stream Capabilities *Type:N/A* *Size:N/A*

Value	Description
N/A	List of Capabilities of the addressed SEP. Capability data are identified for each supported category

Stream Handle *Type: uint* *Size: 2 octets*

Value	Description
0xXXXX	Stream Handle used to address a configuring or configured Stream End Point until the stream is released

List of Stream Configuration parameters *Type:N/A* *Size:N/A*

Value	Description
N/A	List of Capabilities/Configuration parameters of the addressed SEP. Capability/Configuration data are identified for each supported category

[First failing Stream Configuration category] *Type: uint* *Size:2 octets*

Value	Description
0xXXXX	First configuration category of the addressed SEP that failed in a configuration attempt. An error code is provided to why this service category could not be configured.

List of Stream Handles *Type:* *Size: octetst*

Value	Description
N/A	List of Stream Handles of addressed SEP's in a Start or Suspend procedure.

List of Reconfigurable Stream Configuration parameters *Type:N/A* *Size:N/A*

Value	Description
N/A	List of Configuration parameters of the addressed SEP. Configuration data are identified for each supported category. Only reconfigurable parameters are accepted.

Length of Security Control Data *Type: uint* *Size: 2 octet*

Value	Description
0xXXXX	Length of Security Control data to be sent to the remote side.

Security Control Data *Type: N/A* *Size:N/A*

Value	Description
N/A	Pointer to a Security Control data buffer to be sent to the remote side.

13.2.1 Connect Request

Service	Input Parameters	Output Parameters
---------	------------------	-------------------

AVDT_Connect_Req	BD_ADDR, [Local side signaling configuration requests]	RSP
------------------	--	-----

Description:

This AVDTP primitive is use to request a channel connection to a distant AVDTP entity.

Input Parameters:

BD_ADDR *Type: uint* *Size: 6 octets*

Value	Description
0XXXXXXXXXXXXX	Unique Bluetooth address of the distant device

[Local side signaling configuration requests] *Type: N/A* *Size: N/A*

Value	Description
N/A	L2CAP configuration options as requested by the local application (InMTU, OutFlow, OutFlushTO, LinkTO - see L2CAP relevant specification)

Output Parameters:

RSP *Type: uint* *Size: 2 octets*

Value	Description
0x0000	Request accepted
0x0001-0xFFFF	Request rejected (value is implementation dependent)

13.2.2 Connect Response

Service	Input Parameters	Output Parameters
AVDT_Connect_Rsp	BD_ADDR, Connect Result, Status, [Local side configuration requests]	Config Result

Description:

This AVDTP primitive is use to respond to an AVDT_ConnectReq_Ind event.

Input Parameters:

BD_ADDR *Type: uint* *Size: 6 octets*

Value	Description
0XXXXXXXXXXXXX	Unique Bluetooth address of the distant device

Connect Result *Type: uint* *Size: 2 octets*

Value	Description
0XXXXX	L2CAP Connect Response Result (See relevant specification)

Status *Type: uint* *Size: 2 octets*

Value	Description
0XXXXX	L2CAP Connect Response Status (See relevant specification)

[Local side signaling
 configuration
 response]

Type: N/A

Size: N/A

Value	Description
N/A	L2CAP configuration options that are accepted by the local application (OutMTU, InFlow - see L2CAP relevant specification). Those values are returned to the requesting side

Output Parameters:

Config Result

Type: uint

Size: 2 octets

Value	Description
0xXXXX	L2CAP ConfigureResponse Result (See relevant specification)

13.2.3 Disconnect Request

Service	Input Parameters	Output Parameters
AVDT_Disconnect_Req	BD_ADDR	RSP

Description:

This AVDTP primitive is used to request the disconnection of an existing channel between the local entity and a peer device.

Input Parameters:

BD_ADDR

Type: uint

Size: 6 octets

Value	Description
0XXXXXXXXXXXXX	Unique Bluetooth address of the distant device

Output Parameters:

RSP

See § 13.2.1

13.2.4 Stream Discover Request

Service	Input Parameters	Output Parameters
AVDT_Discover_Req	BD_ADDR	Transaction, RSP

Description:

This AVDTP primitive is used by the local application to request the list of Stream End Points a connected distant device exposes for AV stream connections.

Input Parameters:

BD_ADDR

Type: uint

Size: 6 octets

Value	Description
0XXXXXXXXXXXXX	Unique Bluetooth address of the distant device

Output Parameters:

Transaction

Type: uint

Size: 1 octet

Value	Description
0xXX	Identifier of the transaction, which the event relates to

RSP

see § 13.2.1

13.2.5 Stream Discover Response

Service	Input Parameters	Output Parameters
AVDT_Discover_Rsp	Transaction, BD_ADDR, [List of ACP SEID primary data], [Error Code]	RSP

Description:

This AVDTP primitive is used by the local application in response to an AVDT_Discover_Ind event received from the local entity.

Input Parameters:

Transaction *Type: uint* *Size: 1 octet*

Value	Description
0xXX	Identifier of the transaction, which the event relates to. The application shall use the value of the transaction parameter provided by the matching AVDT_Discover_Ind callback

BD_ADDR *Type: uint* *Size: 6 octets*

Value	Description
0XXXXXXXXXXXXX	Unique Bluetooth address of the distant device

[List of ACP SEIDs primary data] *Type:N/A* *Size:N/A*

Value	Description
N/A	List of available ACP SEID's including the In Use indication, Media Type and SEP type information for each one

[Error Code] *Type: uint* *Size: 1 octet*

Value	Description
0xXX	Error code returned by the calling application

Output Parameters:

RSP

See § 13.2.1

13.2.6 Stream Get Capabilities Request

Service	Input Parameters	Output Parameters
AVDT_Get_Capabilities_Req	BD_ADDR, ACP SEID	Transaction, RSP

Description:

This AVDTP primitive is used by the local application to request the capabilities of a Stream End Point a connected distant device exposes for an AV stream connection.

Input Parameters:

BD_ADDR *Type: uint* *Size: 6 octets*

Value	Description
0XXXXXXXXXXXXX	Unique Bluetooth address of the requesting or responding remote device

ACP SEID *Type: uint* *Size: 1 octet*

Value	Description
0xXX	ACP assigned identity of the addressed Stream End Point

Output Parameters:

Transaction *Type: uint* *Size: 1 octet*

Value	Description
0xXX	Identifier of the transaction, which the event relates to

RSP See § 13.2.1

13.2.7 Stream Get Capabilities Response

Service	Input Parameters	Output Parameters
AVDT_Get_Capabilities_Rsp	Transaction, BD_ADDR, [List of Stream Capabilities], [Error Code]	RSP

Description:

This AVDTP primitive is used by the local application in response to an AVDT_Get_Capabilities_Ind event received from the local entity.

Input Parameters:

Transaction *Type: uint* *Size: 1 octet*

Value	Description
0xXX	Identifier of the transaction, which the event relates to. The application shall use the value of the transaction parameter provided by the matching AVDT_Get_Capabilities_Ind callback

BD_ADDR *Type: uint* *Size: 6 octets*

Value	Description
0XXXXXXXXXXXXX	Unique Bluetooth address of the distant device

[List of Stream Capabilities] *Type: N/A* *Size: N/A*

Value	Description
N/A	List of Capabilities of the addressed SEP. Capability data are identified for each supported category

[Error Code] *Type: uint* *Size: 1 octet*

Value	Description
0xXX	Error code returned by the calling application

Output Parameters:

RSP See § 13.2.1

13.2.8 Set Configuration Request

Service	Input Parameters	Output Parameters
AVDT_Set_Configuration_Req	BD_ADDR, ACP SEID, INT SEID, List of Stream	Transaction, Stream Handle,

	Configuration parameters	RSP
--	--------------------------	-----

Description:

This AVDTP primitive is used by the local application to request transport and application service settings for a Stream End Point a connected distant device exposes for an AV stream connection. The Stream End Point is referenced by both initiator and acceptor SEID assignments. The service returns the Stream Handle to be used in future transaction that addresses the configured Stream End Point.

Input Parameters:

BD_ADDR *Type: uint* *Size: 6 octets*

Value	Description
0XXXXXXXXXXXXX	Unique Bluetooth address of the distant device

ACP SEID *Type: uint* *Size: 1 octet*

Value	Description
0xXX	ACP assigned identity of the addressed Stream End Point

INT SEID *Type: uint* *Size: 1 octet*

Value	Description
0xXX	INT assigned identity of the addressed Stream End Point

List of Stream Configuration parameters *Type: N/A* *Size:N/A*

Value	Description
N/A	List of Configuration parameters of the addressed SEP. Configuration data are identified for each supported category

Output Parameters:

Transaction *Type: uint* *Size: 1 octet*

Value	Description
0xXX	Identifier of the transaction, which the event relates to

Stream Handle *Type: uint* *Size: 2 octet*

Value	Description
0XXXXX	Stream Handle used to address the Stream End Point in future transactions

RSP see § 13.2.1

13.2.9 Set Configuration Response

Service	Input Parameters	Output Parameters
AVDT_Set_Configuration_Rsp	Transaction, Stream Handle, [List of failing Stream Configuration Categories]	RSP

Description:

This AVDTP primitive is used by the local application in response to an AVDT_Set_Configuration_Ind event received from the local entity.

Input Parameters:

Transaction *Type: uint* *Size: 1 octet*

Value	Description
0xXX	Identifier of the transaction, which the event relates to. The application shall use the value of the transaction parameter provided by the matching AVDT_Set_Configuration_Ind callback

Stream Handle *Type: uint* *Size: 2 octet*

Value	Description
0XXXXX	Stream Handle that identifies the configured stream end point addressed by this transaction

[List of failing Stream Configuration categories] *Type: N/A* *Size:N/A*

Value	Description
N/A	List of Configuration categories of the addressed SEP that failed in the configuration attempt. Failing configuration data are identified for each un-configurable category and an error code is provided for each one.

Output Parameters:

RSP

See § 13.2.1

13.2.10 Get Configuration Request

Service	Input Parameters	Output Parameters
AVDT_Get_Configuration_Req	Stream Handle	Transaction, RSP

Description:

This AVDTP primitive is used by the local application to retrieve the configuration parameters of a Stream End Point a connected distant device exposes for an AV stream connection. The service uses the Stream Handle to address the configured Stream End Point.

Input Parameters:

Stream Handle *Type: uint* *Size: 2 octet*

Value	Description
0XXXXX	Stream Handle that identifies a configured stream end point to be addressed by this transaction

Output Parameters:

Transaction *Type: uint* *Size: 1 octet*

Value	Description
0xXX	Identifier of the transaction, which the event relates to.

RSP

See § 13.2.1

13.2.11 Get Configuration Response

Service	Input Parameters	Output Parameters
AVDT_Get_Configuration_Rsp	Transaction, Stream Handle, [List of Stream Configuration Parameters], [Error Code]	RSP

Description:

This AVDTP primitive is used by the local application in response to an AVDT_Get_Configuration_Ind event received from the local entity.

Input Parameters:

Transaction *Type: uint* *Size: 1 octet*

Value	Description
0xXX	Identifier of the transaction, which the event relates to. The application shall use the value of the transaction parameter provided by the matching AVDT_Get_Configuration_Ind callback

Stream Handle *Type: uint* *Size: 2 octet*

Value	Description
0xXXXX	Stream Handle that identifies the configured stream end point addressed by this transaction

[List of Stream Configuration parameters] *Type: N/A* *Size: N/A*

Value	Description
N/A	List of Configuration parameters of the addressed SEP. Configuration data are identified for each supported category

[Error Code] *Type: uint* *Size: 1 octet*

Value	Description
0xXX	Error code returned by the calling application

Output Parameters:

RSP See § 13.2.1

13.2.12 Open Stream Request

Service	Input Parameters	Output Parameters
AVDT_Open_Req	Stream Handle	Transaction, RSP

Description:

This AVDTP primitive is used by the local application to request a stream connection with a connected distant device. The service uses a valid stream handle allocated for the addressed stream end point during previous SEP configuration procedures.

Input Parameters:

Stream Handle *Type: uint* *Size: 2 octet*

Value	Description
0xXXXX	Stream Handle that identifies a configured stream end point to be addressed by this transaction

Output Parameters:

Transaction *Type: uint* *Size: 1 octet*

Value	Description
0xXX	Identifier of the transaction, which the event relates to

RSP

See § 13.2.1

13.2.13 Open Stream Response

Service	Input Parameters	Output Parameters
AVDT_Open_Rsp	Transaction, Stream Handle, [Error Code]	RSP

Description:

This AVDTP primitive is used by the local application in response to an AVDT_Open_Ind event received from the local entity.

Input Parameters:

<i>Transaction</i> <i>Type: uint</i> <i>Size: 1 octet</i>	
Value	Description
0xXX	Identifier of the transaction, which the event relates to. The application shall use the value of the transaction parameter provided by the matching AVDT_Open_Ind callback

<i>Stream Handle</i> <i>Type: uint</i> <i>Size: 2 octet</i>	
Value	Description
0xXXXX	Stream Handle that identifies the configured stream end point addressed by this transaction

<i>[Error Code]</i> <i>Type: uint</i> <i>Size: 1 octet</i>	
Value	Description
0xXX	Error code returned by the calling application

Output Parameters:

RSP

see § 13.2.1

13.2.14 Close Stream Request

Service	Input Parameters	Output Parameters
AVDT_Close_Req	Stream Handle	Transaction, RSP

Description:

This AVDTP primitive is used by the local application to request a stream connection to be released. The stream handle the local AVDTP entity has allocated to a configured stream end-point refers the stream connection.

Input Parameters:

<i>Stream Handle</i> <i>Type: uint</i> <i>Size: 2 octet</i>	
Value	Description
0xXXXX	Stream Handle that identifies a configured stream end point to be addressed by this transaction

Output Parameters:

<i>Transaction</i> <i>Type: uint</i> <i>Size: 1 octet</i>	
Value	Description
0xXX	Identifier of the transaction, which the event relates to

RSP

see § 13.2.1

13.2.15 Close Stream Response

Service	Input Parameters	Output Parameters
AVDT_Close_Rsp	Transaction, Stream Handle, [Error Code]	RSP

Description:

This AVDTP primitive is used by the local application in response to an AVDT_Close_Ind event received from the local entity.

Input Parameters:

Transaction *Type: uint* *Size: 1 octet*

Value	Description
0xXX	Identifier of the transaction, which the event relates to. The application shall use the value of the transaction parameter provided by the matching AVDT_Close_Ind callback

Stream Handle *Type: uint* *Size: 2 octet*

Value	Description
0xXXXX	Stream Handle that identifies the configured stream end point addressed by this transaction

[Error Code] *Type: uint* *Size: 1 octet*

Value	Description
0xXX	Error code returned by the calling application

Output Parameters:

RSP

See § 13.2.1

13.2.16 Start Stream Request

Service	Input Parameters	Output Parameters
AVDT_Start_Req	List of Stream Handles	Transaction, RSP

Description:

This AVDTP primitive is used by the local application to start media streaming on one or more open stream connections with a connected distant device in a synchronous way. The service uses a list of valid stream handles allocated for the addresses stream end-points during individual SEP configuration procedures.

Input Parameters:

List of Stream Handles *Type: uint* *Size: 2 octet*

Value	Description
0xXXXX	List of Stream Handles that identity the configured stream end points to be addressed by this transaction

Output Parameters:

Transaction *Type: uint* *Size: 1 octet*

Value	Description
-------	-------------

0xXX	Identifier of the transaction, which the event relates to
------	---

RSP

See § 13.2.1

13.2.17 Start Stream Response

Service	Input Parameters	Output Parameters
AVDT_Start_Rsp	Transaction, [First Failing Streaming Handle] [Error Code]	RSP

Description:

This AVDTP primitive is used by the local application in response to an AVDT_Start_Ind event received from the local entity.

Input Parameters:

Transaction *Type: uint* *Size: 1 octet*

Value	Description
0xXX	Identifier of the transaction, which the event relates to. The application shall use the value of the transaction parameter provided in the matching AVDT_Start_Ind callback

First Stream Handle *Type: uint* *Size: 2 octet*

Value	Description
0xXXXX	Stream Handle that identifies the first stream handle of the list provided in the matching AVDT_Start_Ind callback

[First Failing Stream Handle] *Type: uint* *Size: 2 octet*

Value	Description
0xXXXX	Stream Handle that identifies the first configured stream end point addressed by this transaction that failed to start.

[Error Code] *Type: uint* *Size: 1 octet*

Value	Description
0xXX	Error code returned by the calling application

Output Parameters:

RSP

See § 13.2.1

13.2.18 Suspend Request

Service	Input Parameters	Output Parameters
AVDT_Suspend_Req	List of Stream Handles	Transaction, RSP

Description:

This AVDTP primitive is used by the local application to suspend media streaming on one or more streaming connections with a connected distant device in a synchronous way. The service uses a list of valid stream handles allocated for the addresses stream end-points during individual SEP configuration procedures.

Input Parameters:

List of Stream Handles *Type: uint* *Size: 2 octet*

Value	Description
0xXXXX	List of Stream Handles that identify the configured stream end points to be addressed by this transaction

Output Parameters:

Transaction *Type: uint* *Size: 1 octet*

Value	Description
0xXX	Identifier of the transaction, which the event relates to

RSP See § 13.2.1

13.2.19 Suspend Response

Service	Input Parameters	Output Parameters
AVDT_Suspend_Rsp	Transaction, First Stream Handle, [First Failing Stream Handle], [Error Code]	RSP

Description:

This AVDTP primitive is used by the local application in response to an AVDT_Suspend_Ind event received from the local entity.

Input Parameters:

Transaction *Type: uint* *Size: 1 octet*

Value	Description
0xXX	Identifier of the transaction, which the event relates to. The application shall use the value of the transaction parameter provided in the matching AVDT_Suspend_Ind callback

First Stream Handle *Type: uint* *Size: 2 octet*

Value	Description
0xXXXX	Stream Handle that identifies the first stream handle of the list provided in the matching AVDT_Suspend_Ind callback

[First Failing Stream Handle] *Type: uint* *Size: 2 octet*

Value	Description
0xXXXX	Stream Handle that identifies the first configured stream end point addressed by this transaction that failed to start.

[Error Code] *Type: uint* *Size: 1 octet*

Value	Description
0xXX	Error code returned by the calling application

Output Parameters:

RSP See § 13.2.1

13.2.20 Reconfigure Request

Service	Input Parameters	Output Parameters
AVDT_ReConfigure_Req	Stream Handle, List of	Transaction, RSP

	Reconfigurable Stream Configuration parameters	
--	--	--

Description:

This AVDTP primitive is used by the local application to renegotiate application settings of a suspended media stream. The stream handle the local AVDTP entity has allocated to a configured stream end-point refers the stream connection.

Input Parameters:

<i>Stream Handle</i>	<i>Type: uint</i>	<i>Size: 2 octet</i>
Value	Description	
0xXXXX	Stream Handle that identifies a configured stream end point to be addressed by this transaction	

<i>List of Reconfigurable Stream Configuration parameters</i>	<i>Type:N/A</i>	<i>Size:N/A</i>
Value	Description	
N/A	List of Configuration parameters of the addressed SEP. Configuration data are identified for each supported category. Only reconfigurable parameters are accepted.	

Output Parameters:

<i>Transaction</i>	<i>Type: uint</i>	<i>Size: 1 octet</i>
Value	Description	
0xXX	Identifier of the transaction, which the event relates to	

RSP See § 13.2.1

13.2.21 Reconfigure Response

Service	Input Parameters	Output Parameters
AVDT_ReConfigure_Rsp	Transaction, Stream Handle, [Error Code]	RSP

Description:

This AVDTP primitive is used by the local application in response to an AVDT_ReConfigure_Ind event received from the local entity.

Input Parameters:

<i>Transaction</i>	<i>Type: uint</i>	<i>Size: 1 octet</i>
Value	Description	
0xXX	Identifier of the transaction, which the event relates to. The application shall use the value of the transaction parameter provided by the matching AVDT_Reconfigure_Ind callback	

<i>Stream Handle</i>	<i>Type: uint</i>	<i>Size: 2 octet</i>
Value	Description	
0xXXXX	Stream Handle that identifies the configured stream end point addressed by this transaction	

[Error Code] Type: uint Size: 1 octet

Value	Description
0xXX	Error code returned by the calling application

Output Parameters:

RSP See § 13.2.1

13.2.22 Security Control Request

Service	Input Parameters	Output Parameters
AVDT_Security_Control_Req	Stream Handle, Length of Security Control data, Security Control data	Transaction, RSP

Description:

This AVDTP primitive is used by the local application to request to exchange Content Security data information about a stream connection. The stream handle the local AVDTP entity has allocated to a configured stream end-point refers the stream connection.

Input Parameters:

Stream Handle Type: uint Size: 2 octet

Value	Description
0xXXXX	Stream Handle that identifies a configured stream end point to be addressed by this transaction

Length of Security Control Data Type: uint Size: 2 octet

Value	Description
0xXXXX	Length of Security Control data to be sent to the remote side.

Security Control Data Type:N/A Size:N/A

Value	Description
N/A	Security Control data sent to be sent to the remote side.

Output Parameters:

Transaction Type: uint Size: 1 octet

Value	Description
0xXX	Identifier of the transaction, which the event relates to

RSP See § 13.2.1

13.2.23 Security Control Response

Service	Input Parameters	Output Parameters
AVDT_Security_Control_Rsp	Transaction, Stream Handle, [Length of Security Control data], [Security Control data], [Error Code]	RSP

Description:

This AVDTP primitive is used by the local application in response to an AVDT_Security_Control_Ind event received from the local entity.

Input Parameters:

<i>Transaction</i> <i>Type: uint</i> <i>Size: 1 octet</i>	
Value	Description
0xXX	I Identifier of the transaction, which the event relates to. The application shall use the value of the transaction parameter provided by the matching AVDT_Security_Control_Ind callback

<i>Stream Handle</i> <i>Type: uint</i> <i>Size: 2 octet</i>	
Value	Description
0xXXXX	Stream Handle that identifies the configured stream end point addressed by this transaction

<i>[Length of Security Control Data]</i> <i>Type: uint</i> <i>Size: 2 octet</i>	
Value	Description
0xXXXX	Length of Security Control data to be sent to the remote side.

<i>[Security Control Data]</i> <i>Type:N/A</i> <i>Size:N/A</i>	
Value	Description
N/A	Security Control data to be sent to the remote side.

<i>[Error Code]</i> <i>Type: uint</i> <i>Size: 1 octet</i>	
Value	Description
0xXX	Error code returned by the calling application

Output Parameters:

RSP See § 13.2.1

13.2.24 Abort Request

Service	Input Parameters	Output Parameters
AVDT_Abort_Req	Stream Handle	Transaction, RSP

Description:

This AVDTP primitive is used by the local application to abort a stream connection. The stream handle the local AVDTP entity has allocated to a configured stream end- point refers the stream connection.

Input Parameters:

<i>Stream Handle</i> <i>Type: uint</i> <i>Size: 2 octet</i>	
Value	Description
0xXXXX	Stream Handle that identifies a configured stream end point to be addressed by this transaction

Output Parameters:

<i>Transaction</i> <i>Type: uint</i> <i>Size: 1 octet</i>	
Value	Description
0xXX	Identifier of the transaction, which the event relates to

RSP

See § 13.2.1

13.2.25 Abort Response

Service	Input Parameters	Output Parameters
AVDT_Abort_Rsp	Transaction, Stream Handle, [Error Code]	RSP

Description:

This AVDTP primitive is used by the local application in response to an AVDT_Abort_Ind event received from the local entity.

Input Parameters:

Transaction *Type: uint* *Size: 1 octet*

Value	Description
0xXX	Identifier of the transaction, which the event relates to. The application shall use the value of the transaction parameter provided by the matching AVDT_Abort_Ind callback

Stream Handle *Type: uint* *Size: 2 octet*

Value	Description
0xXXXX	Stream Handle that identifies the configured stream end point addressed by this transaction

[Error Code] *Type: uint* *Size: 1 octet*

Value	Description
0xXX	Error code returned by the calling application

Output Parameters:

RSP

See § 13.2.1

13.3 Media Transport service interface

13.3.1 Write Stream Data

Service	Input Parameters	Output Parameters
AVDT_Write_Req	Stream Handle, Length, OutBuffer, TimeInfo, Payload Type, Marker	Result

Description:

This AVDTP primitive is used to send a frame of streaming data to the peer device. Internally, AVDTP maps this media frame as the payload of a single media packet (or to multiple packets, if fragmentation is used). The format of the frame is specified by the payload definition given by an application profile. To meet the real time requirements, the application **shall** provide timing information associated to the media frame.

Input Parameters:

Stream Handle *Type: uint* *Size: 2 octets*

Value	Description
-------	-------------

0xXXXX	Stream Handle provided by the local AVDTP during Stream Configuration
--------	---

Length *Type: uint* *Size: 2 octets*

Value	Description
0xXXXX	Length, in bytes, of stream data frame buffer

OutBuffer *Type: pointer* *Size: N/A*

Value	Description
N/A	Address of application data buffer where the service can read the frame of media stream data.

TimeInfo *Type: uint* *Size: 4/8 octets*

Value	Description
0xXXXX	Timing information associated with the media frame

Payload Type *Type: uint* *Size: 1 octet*

Value	Description
0xXX	Indicates the content type of the read stream data.

Marker *Type: uint* *Size: 2 octets*

Value	Description
0xXXXX	Marker bit (valid values: 1 or 0); to be inserted into AVDTP (RTP) packet header, can be used by certain codec payload formats

Output Parameters:

Result *Type: uint* *Size: 2 octets*

Value	Description
0x0000	Stream data frame accepted for transmission
0x0001	Insufficient resources: AVDTP buffer overflow
0x0002	Invalid stream handle
Other	RFD

13.3.2 Read Stream Data

Service	Input Parameters	Output Parameters
AVDT_ReadStreamData	Stream Handle, ExpLength, InBuffer	Result, Length, TimeInfo, Marker, Payload Type, Reliability

Description:

This AVDTP primitive is used to receive a frame of streaming data from the peer device. Internally, AVDTP maps this media frame from the payload of a single media packet (or to multiple packets, if fragmentation is used). The format of the frame is specified by the payload definition given by an application profile. To meet the real time requirements, timing information (timestamp) **shall** be conveyed to the application.

Input Parameters:

Stream Handle *Type: uint* *Size: 2 octets*

Value	Description
-------	-------------

0xXXXX	Stream Handle provided by the local AVDTP during Stream Configuration
--------	---

ExpLength *Type: uint* *Size: 2 octets*

Value	Description
0xXXXX	Maximum length, in bytes, of frame buffer, thus expected length of media frame.

Payload Type *Type: uint* *Size: 1 octet*

Value	Description
0xXX	Indicates the content type of the read stream data.

InBuffer *Type: pointer* *Size: N/A*

Value	Description
N/A	Address of application data buffer where the service can write the frame of received media stream data.

Output Parameters:

Result *Type: uint* *Size: 2 octets*

Value	Description
0x0000	Successful transfer of stream data
0x0001	AVDTP buffer underflow, no data available
0x0002	Invalid stream handle
0x0003	Warning: data received, which can be unreliable/corrupted though: see Reliability information
Other	RFD

Length *Type: uint* *Size: 2 octets*

Value	Description
0xXXXX	Actual length of received media frame.

TimeInfo *Type: uint* *Size: 4/8 octets*

Value	Description
0xXXXX	Timing information associated with the media frame

Marker *Type: uint* *Size: 2 octets*

Value	Description
0xXXXX	Marker bit (valid values: 1 or 0); extracted from AVDTP (RTP) packet header, can be used by certain codec payload formats

Reliability *Type: uint* *Size: 2 octets*

Value	Description
0x0000	No errors detected in received data
0x0001	Media frame/packet lost
0x0002	Media frame results from packet recovery operation
0x0003	Mismatch of expected and actual frame length
Other	RFD

14 APPENDIX B – Multiplexing Service Example (informative)

Assume a configuration of two streams, which are configured as follows:

- Stream #1 (SEID₁, Video): uses reporting and recovery service
- Stream #2 (SEID₂, Audio): uses reporting, but no recovery service

Consequently, three transport sessions (TSID₁, TSID₂, and TSID₃) are opened for Stream #1, and 2 transport sessions (TSID₄, TSID₅) for Stream #2.

14.1 Packetization in Basic Service Mode

In Basic Service Mode, individual L2CAP channels are opened for each transport session, and every transport packet is sent in a separate L2CAP packet.

In the following figure, transport channels A, B, C, D, E **shall** be connected during the stream establishment procedure. TSIDs and TCIDs are not explicitly used; the correct mapping of transport channels to transport session is achieved by the procedure (channel set up in the order media – reporting – recovery).

For clarification only, extra identifiers describe the packets in this figure.

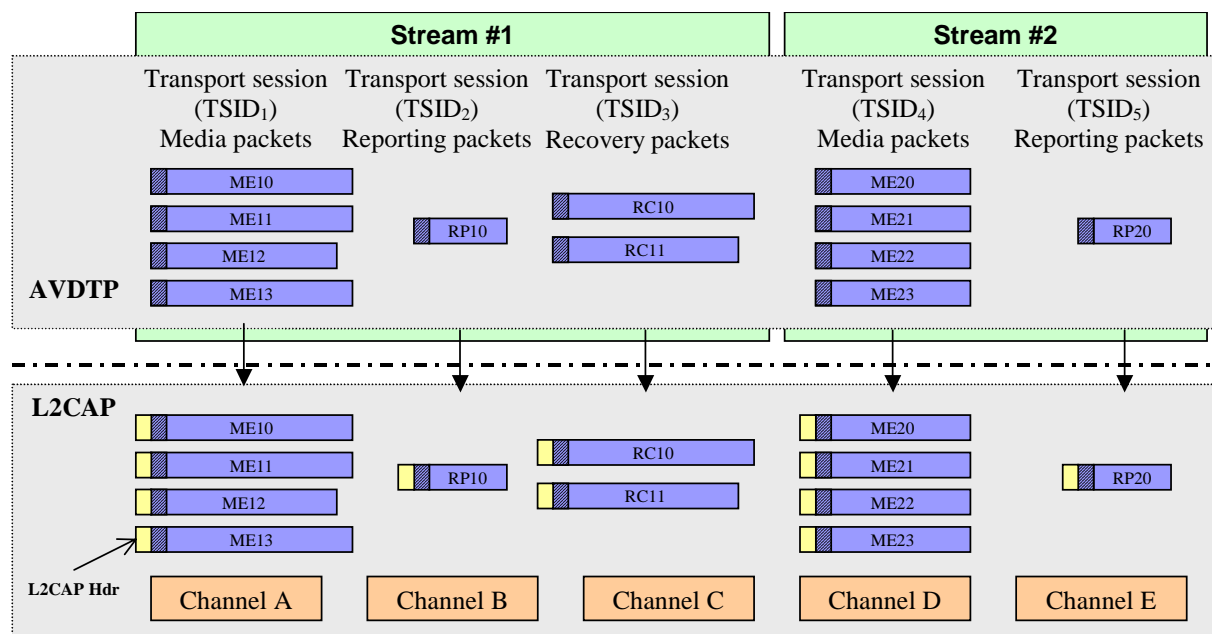

14.2 Packetization in Multiplexing Mode

The goal of the multiplexing service of the AVDTP Adaptation Layer is as follows:

- To enable multiple AVDTP packet types (media/reporting/recovery) to share a single L2CAP payload.
- To enable multiple transport sessions, of one or more stream, to share a single L2CAP channel.

Starting from the same stream/session configuration as in the previous section, now the use of transport channels in Multiplexing Mode **shall** be shown. Assume that two transport channels **shall** be configured, where the channel usage is configured as follows:

- Channel A: Media and Reporting packets of Stream #1
- Channel B: Media and Reporting packets of Stream #2, Recovery packets of Stream #1

Consequently, packetization could occur as depicted in this figure:

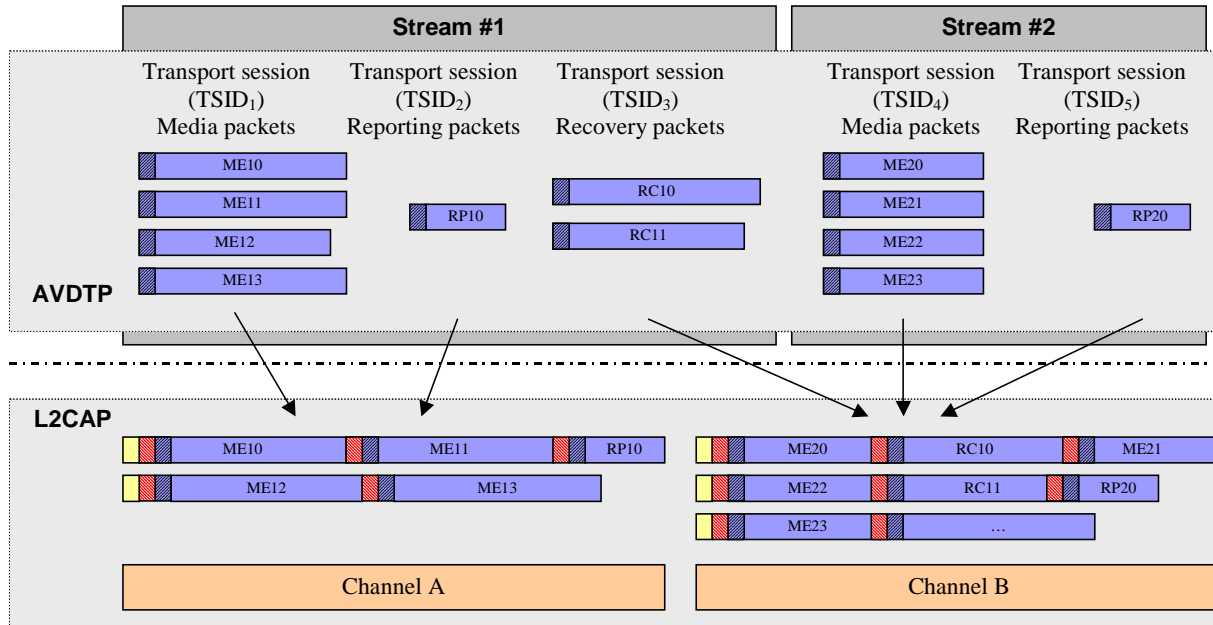

15 APPENDIX C – Content Protection Procedure (informative)

For example, the Service Capabilities field of the stream supporting only CP_Type_A is as follows.

7	6	5	4	3	2	1	0	Octet
Service Category = Content Protection								0
LOSC = (n-1 bytes)								1
CP_TYPE_LSB = CP_TYPE_A_LSB								2
CP_TYPE_MSB = CP_TYPE_A_MSB								3
CP_Type Specific Values								n

Figure 15.1: Example of Service Parameter message format

Figure 15.2 shows the Content Security Control procedure.

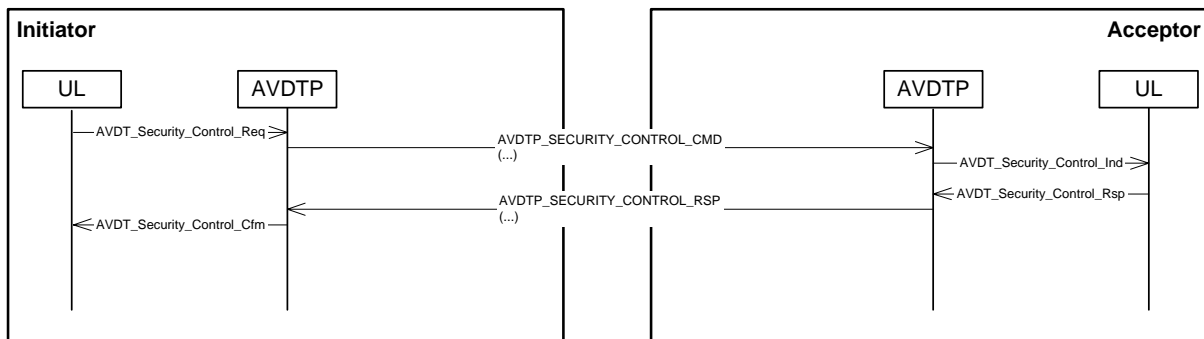

Figure 15.2: Content Security Control Procedure

Following is another example when a stream has two content protection types, CP_Type_A and CP_Type_B.

7	6	5	4	3	2	1	0	Octet
Service Category = Content Protection								0
LOSC = (n1-1)								1
CP_TYPE_LSB = CP_TYPE_A_LSB								2
CP_TYPE_MSB = CP_TYPE_A_MSB								3
CP_Type_A Specific Values								n1
Service Category = Content Protection								n1 +1
LOSC = (n2 - 1)								n1 +2
CP_TYPE_LSB = CP_TYPE_B_LSB								n1 +3
CP_TYPE_MSB = CP_TYPE_B_MSB								n1 +4
CP_Type_B Specific Values								N2

Figure 15.3: Example of Service Parameter message format

The INT selects the required content protection type. The INT specifies the content protection type by the SET_CONFIGURATION_CMD to the ACP. Figure 15.3, shows an example when CP_Type_A is selected. The result is sent back to the INT in the SET_CONFIGURATION_RSP.

16 APPENDIX D – Transport and Streaming Considerations (informative)

16.1 Synchronization Definitions

Implementers of this protocol **should** note that the following types of synchronization areas **should** be considered, these are:

- **Clock Synchronization** – This is a quite general problem of keeping two distant clocks in synchronization.
- **Intra-Stream Synchronization** – Control the speed of stream rendering in the remote device.
- **Inter-Stream Synchronization** – A Device receives media streams from more than one device.
- **Indirect Inter-Stream Synchronization** – A Device sends a media stream to another Device and renders a media stream locally. An example could be a video viewer with a distant loudspeaker.

AVDTP does not provide any additional means for synchronization besides those included in RTP/RTCP.

16.1.1 Clock Synchronization

This is a quite general problem of keeping two distant clocks (thinking more of a wall clock than a codec sample clock) in synchronization. The solution depends on the required accuracy. A software solution could be used; e.g., NTP (Network Time Protocol) or SNTP (Simple Network Time Protocol). The ideal solution is to use hardware connection to the link controller.

16.1.2 Intra-Stream Synchronization

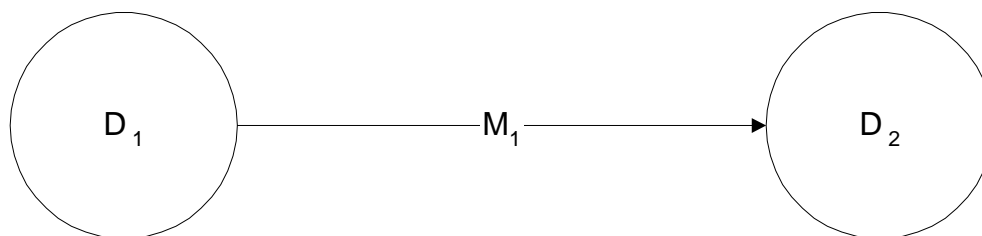

Configuration	Device A sends single stream to device B.
Goal	To control the speed of stream rendering in the remote device.
Solution	We concluded that by having implicit knowledge of frame sizes and using the sequence numbers, this can be solved by buffer management. No timestamps, no clock sync required. Supported; e.g. by A2DP.

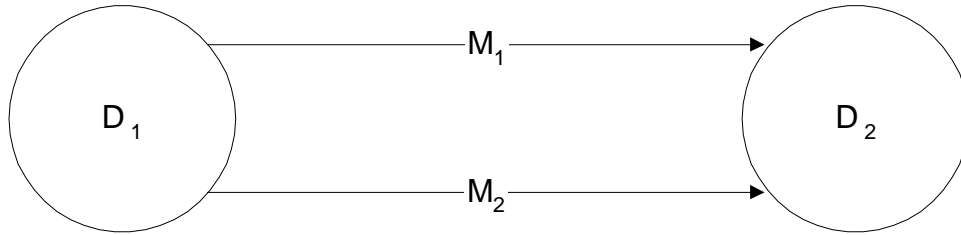

Configuration	Device A sends two (or more) streams to device B.
Goal	Assuming independent sequence number spaces, common (RTP) timestamps are additionally needed to align the rendering of the parallel streams. Absolute time reference is not needed; i.e., no clock sync required -> supported.
Solution	We concluded that by having implicit knowledge of frame sizes and using the sequence numbers, this can be solved by buffer management. No timestamps, no clock sync required. Supported; e.g., by A2DP.

16.1.3 Inter-Stream Synchronization

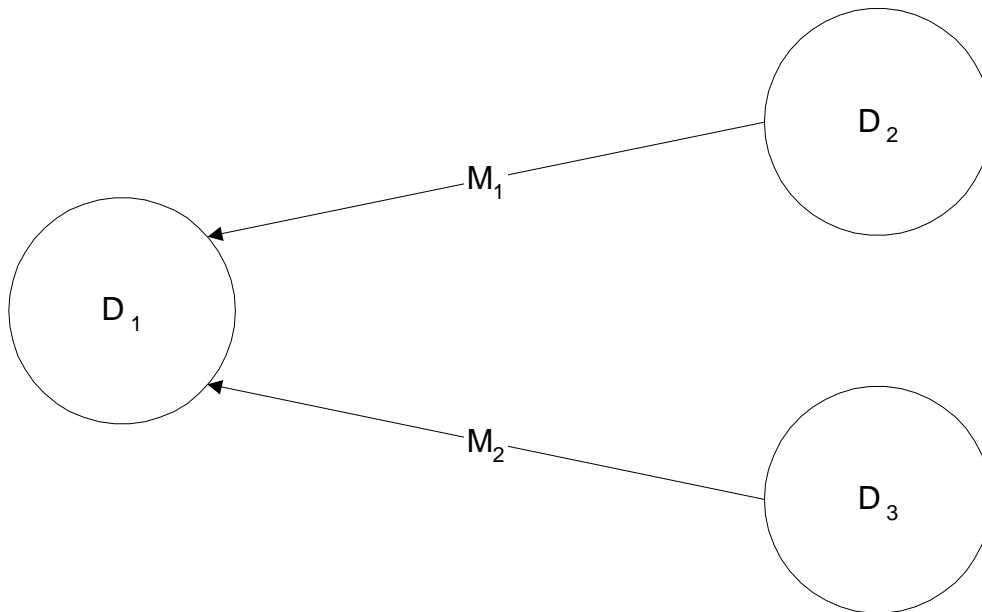

Configuration	D_1 receives media streams (M_1, M_2) from more than one device.
Solution	Wall clock synchronization is required. Here, besides the timestamps, a common time reference is needed in D_2 and D_3 to align the rendering of both streams.

16.1.4 Indirect Inter-Stream Synchronization

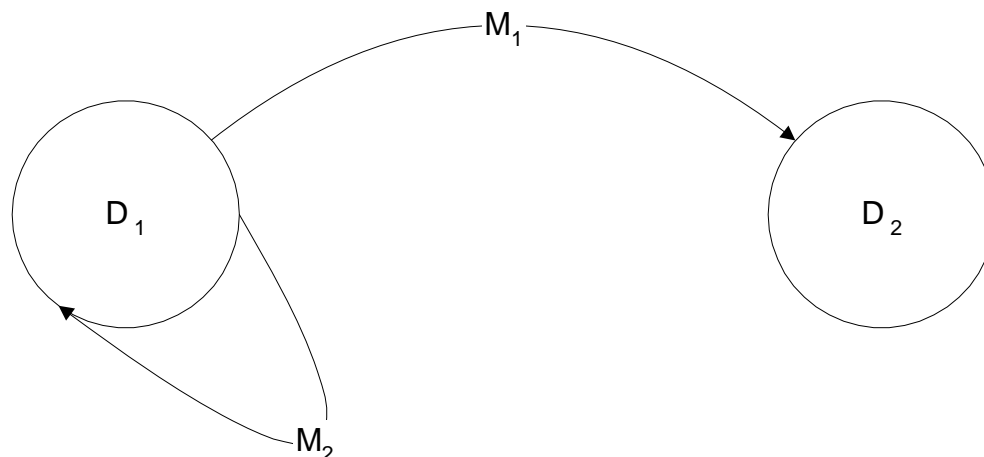

Configuration	D ₁ sends a media stream (M ₁) to D ₂ and renders media stream locally (M ₂). An example would be a video viewer with a distant loudspeaker.
Solution	Here, besides the timestamps, a common time reference is needed in D ₁ and D ₂ to align the rendering of both streams; i.e., a clock.

16.2 Different clocks and Synchronization

RFC 1889 specifies one media-timestamp in the RTP (Real-time Transport Protocol) data header and a mapping between such timestamp and a globally synchronized clock, carried as RTCP timestamp mappings.

The NTP (Network Time Protocol) timestamps, in the SR, are assumed to be synchronized between all media senders within a single session. If the media sources come from the same network source, this is obviously not an issue. Receiver(s) synchronizes to the sender, the only solution feasible for multicast.

Experience has shown that all other cross-media, cross-host schemes end up doing clock synchronization, usually inferior to NTP and application-specific.

16.3 RTP timestamp and Sequence Numbers

The timestamp is used to place the incoming audio and video packets in the correct timing order (play out delay compensation). The sequence number is mainly used to detect losses. Sequence numbers increase by one for each RTP packet transmitted, timestamps increase by the time "covered" by a packet. For video formats where a video frame is split across several RTP packets, several packets **can** have the same timestamp. In some cases such as carrying DTMF (touch tone) data (RFC 2833), RTP timestamps **may** not be monotonic.

16.4 Jitter Calculations

If several packets, say, within a video frame, bear the same timestamp, it is advisable to only use the first packet in a frame to compute the jitter.

Jitter is computed in timestamp units. For example, for an audio stream sampled at 8,000 Hz, the arrival time measured with the local clock is converted by multiplying the seconds by 8,000.

16.5 Media Stream Service Interface

The service primitives for media transport services are necessarily influenced by the underlying system architecture/model for the streaming of real time data.

- **Framed media service interface:** the application exchanges media data with AVDTP on a frame-by-frame basis. The definition of a media "frame" is dependent on the requirements of the profile specification. A frame of media data is fully described by the payload specification, which is identified by the previous stream configuration. Typically, a payload contains one or multiple codec frames, i.e. blocks of binary data resulting from a parametric audio/video codec. If a content protection system is used, the codec data **can** be encrypted, and encapsulated by a CP specific header. It is further assumed that AVDTP aligns such a media frame to the payload of one media packet (or multiple media packets, if fragmentation is used): in other terms, AVDTP maintains the framing structure as imposed by the application layer.
- **Provision of input and output streaming buffer:** it is assumed that an AVDTP implementation **shall** maintain an internal buffer of the media data frames, in order to control the incoming resp. outgoing data flow. This implies that the data flows at the upper (streaming) service interface and the lower interface (towards L2CAP) are, to some extent, asynchronous. This is also motivated by the AVDTP multiplexing mode: the adaptation layer decouples the packet flow between AVDTP upper and lower interfaces.
- **Preserve timing information:** with respect to real-time requirements, AVDTP **should** maintain timing information associated to a media frame. The application is responsible for grabbing the timing information at the signal source and to convey it synchronously to the AVDTP entity. According to this timing information, AVDTP sets the RTP timestamp in its PDUs (media packets). Consequently, the internal buffers of an AVDTP entity **should** store both media frames and its associated timing information.

17 APPENDIX E - Acronyms and Abbreviations

Acronym	Description
A/V	Audio/Video
ACP	Acceptor
AL	Adaptation Layer
AVDTP	Audio/Video Distribution Transport Protocol
C/R	Command/Response
CP_Type	Content Protection Type
CRC	Cyclic Redundancy Check
FEC	Forward Error Correction
FRAG	AL Fragmentation flag
IEEE	The Institute of Electrical and Electronics Engineers, Inc.
IETF	Internet Engineering Task Force
INT	Initiator
LOSC	Length of Service Capabilities
LSB	Least Significant Bit (Byte)
MPEG	Moving Picture Expert Group
MSB	Most Significant Bit (Byte)
MSC	Message Sequence Chart
MTU	Maximum Transmission Unit
NOSP	Number of Signal Packets
PDU	Protocol Data Unit
PSM	Protocol/Service Multiplexer
QoS	Quality of Service
ROHC	Robust Header Compression
RTCP	Real-time Transport Control Protocol
RTP	Real-time Transport Protocol
RTSP	Real-time Streaming Protocol
SBC	Low Complexity Subband Codec
SC	Stream Context
SDP	Service Discovery Protocol
SEID	Stream End Point Identifier
SEP	Stream End Point
SH	Stream Handle
SNK	Sink
SRC	Source
SSRC	Synchronization Source
TBC	To be completed
TBD	To be defined

TBW	To be written
TCID	Transport Channel Identifier
TL	Transaction Label
TSEP	Type of Stream End Point
TSID	Transport Session Identifier